

# AZ68F

DA MAT. 203 REV. 29-04-2024

LOCALE	CODICE	DESCRIZIONE COMPONENTE	FINITURA	Q.TA	OPERATORE
CUCINA A POPPA	AZ68F-R01_KKA01	BASE CUCINA MURATA POPPA	LASTRA CHIARA	7	Damiano

**ID 1401**  
METTERE GOMMINO  
PARACOLPI ANCHE SU  
CASSETTI

**ID 1402**  
NON FARE FORI  
CALAMITE SU ANTA N.5  
NELLA VERSIONE CON  
LAVASTOVIGLIE  
RIMANGONO A VISTA

1 - L 36 x H.740 x sp 16  
2 - 5 - L 449 x H.774 x sp 20  
3 - L 595 x H.163 x sp 20  
4 - L 595 x H.152x sp 20  
6 - L.454 x H.58 x sp 16  
7- L.454 x H.62,5 x sp 16

**ELEMENTO DA MONTARE con:**  
**KKA01**  
**L01\_KKA01**  
**P01\_KKA01**  
**P01\_KKA01**  
e spedire con un unico imballo

**25**  
ZOCOLI DIVENTATI IN

L01\_KKA01  
P01\_KKA01  
KKA01  
R02\_KKA01

# AZ68F

DA MAT. 203 REV. 29-04-2024

LOCALE	CODICE	DESCRIZIONE COMPONENTE	FINITURA	Q.TA	OPERATORE
CUCINA A POPPA	AZ68F-R01_KKB01	BASE CUCINA CENTRONAVE	LASTRA CHIARA	5	Damiano

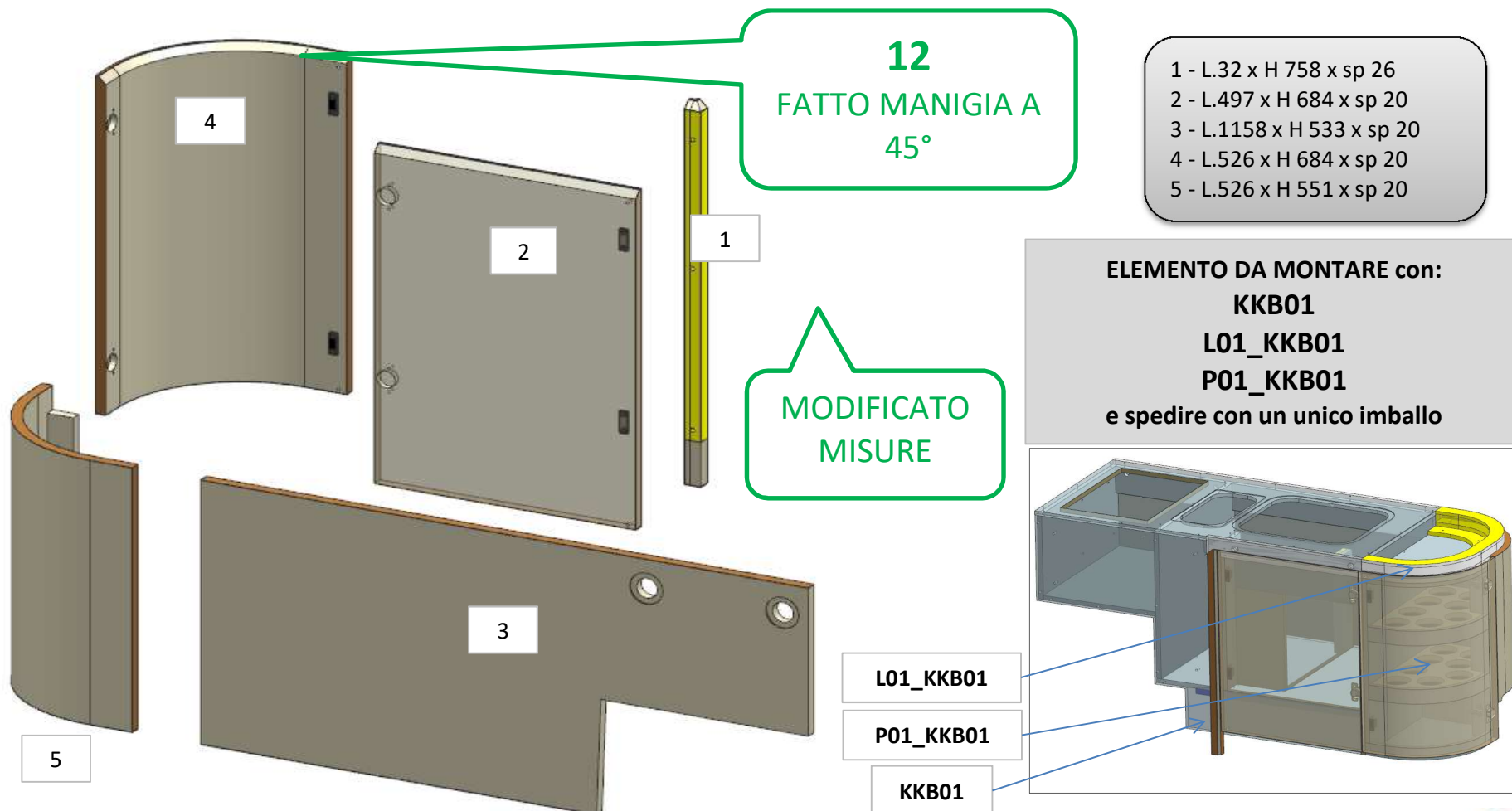

# AZ68F

DA MAT. 203 REV. 29-04-2024

LOCALE	CODICE	DESCRIZIONE COMPONENTE	FINITURA	Q.TA	OPERATORE
CUCINA A POPPA	AZ68F-R01_KKC01	STRUTTURA ZOCCOLO CUCINA	LASTRA CHIARA	1	Damiano

1 - L.1099 x H62,5 x sp 16

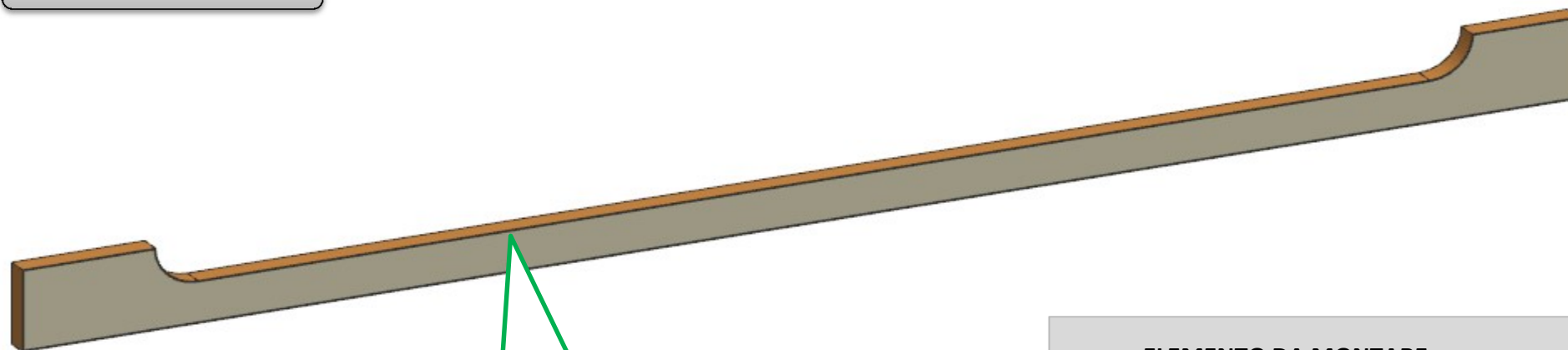

**25**  
ZOCCOLO  
DIVENTATO IN  
LASTRA CHIARA

ELEMENTO DA MONTARE con:  
**KKC01**  
e spedire con un unico imballo

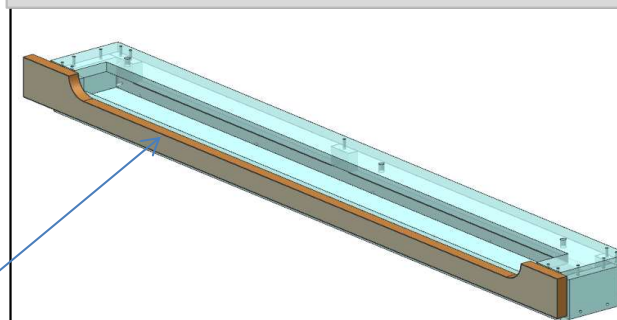

KKC01

**consonni&c**

# AZ68F

DA MAT. 243 REV. 29-04-2024

LOCALE	CODICE	DESCRIZIONE COMPONENTE	FINITURA	Q.TA	OPERATORE
CUCINA A POPPA	AZ68F-R01_KKD01	CASSA FRIGO	LASTRA CHIARA	3	Damiano

1 - L 611 x H.1850 x sp 20  
2 - L 843 x H.1850 x sp 20  
3 - L 592 x H.62,5 x 226

**NB: METTERE  
Distanziale  
CUSTOM PRIMA DI  
SPEDIRE**

**25**  
ZOCCOLO  
DIVENTATO IN  
LASTRA CHIARA

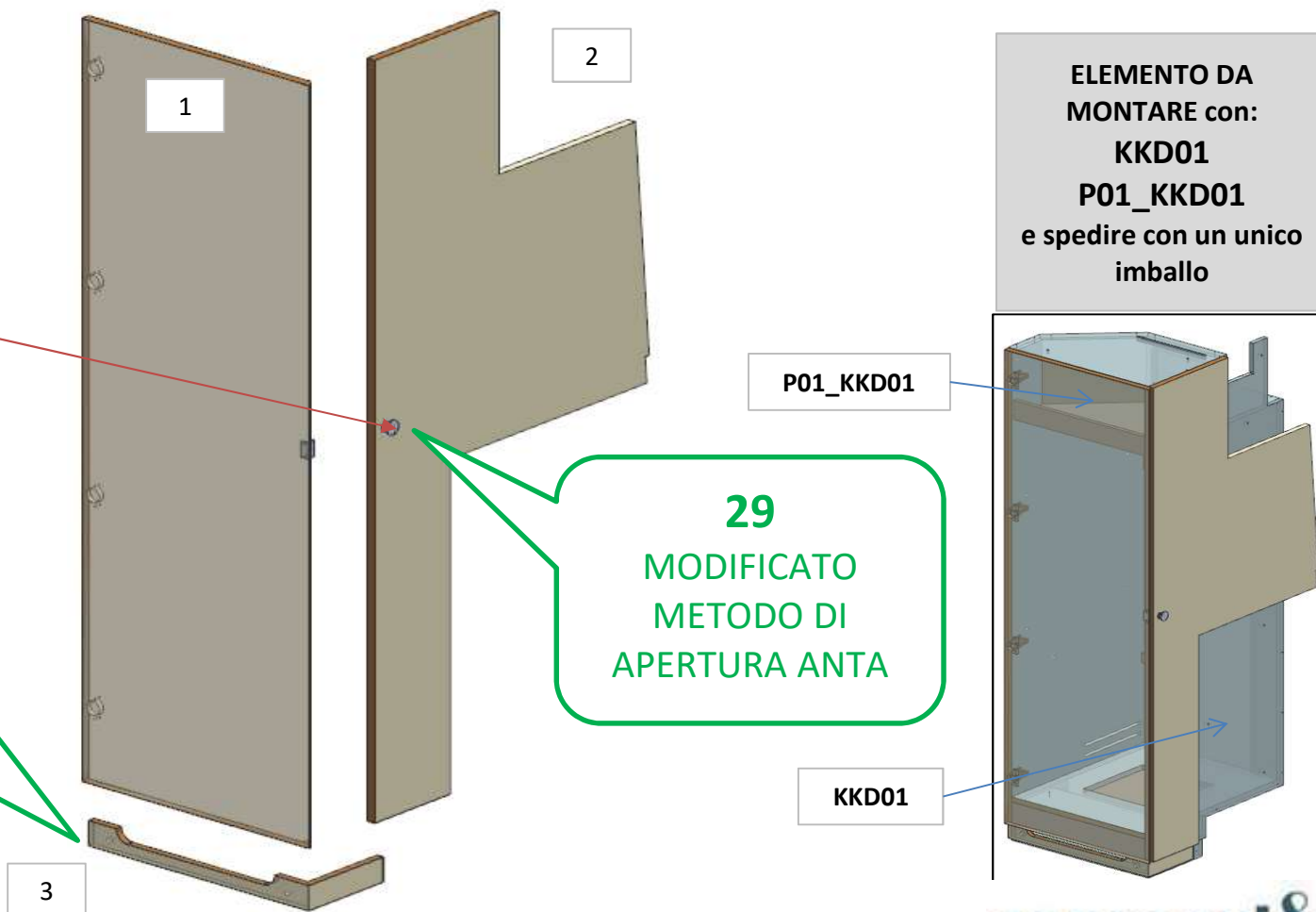

consonni&c

# AZ68F

DA MAT. 212 REV. 29-04-2024

LOCALE	CODICE	DESCRIZIONE COMPONENTE	FINITURA	Q.TA	OPERATORE
CUCINA A POPPA	AZ68F-R01_KKE01	MOBILE TERMINALE POPPA SX	LASTRA CHIARA	3	Damiano

- 1 - L.381 x H 1023 x sp 20mm
- 2 - L 70 x H 1026 x sp 16mm
- 3 - L 102 x H 1122 x sp 16 mm

**17 (step1)**  
MODIFICATE  
DIMENSIONI

102mm

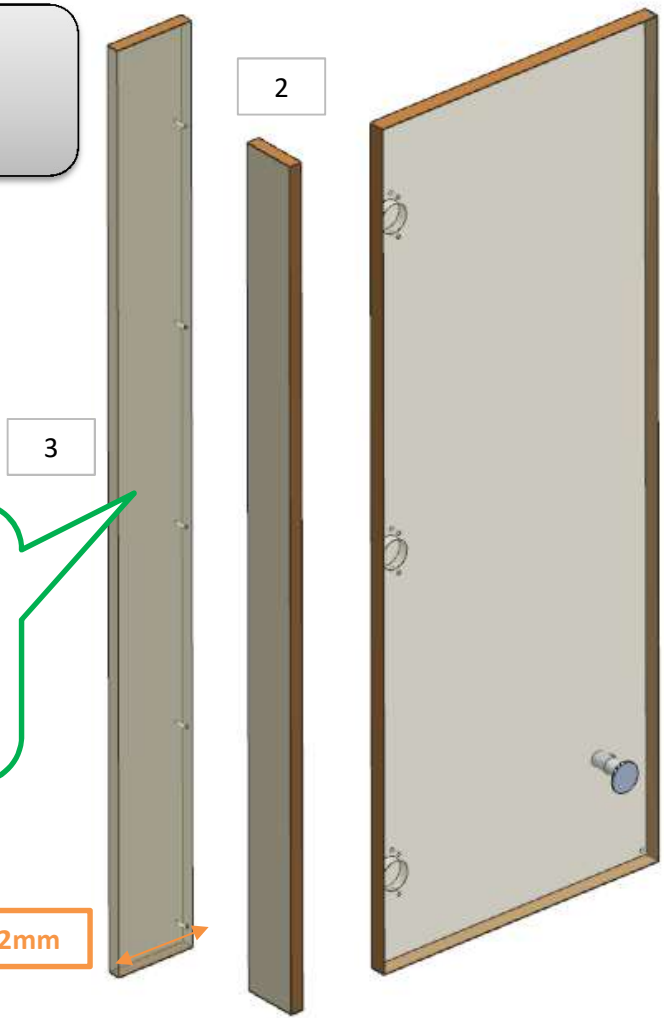

ELEMENTO DA MONTARE con:  
**KKE01**  
**P01\_KKE01**  
e spedire con un unico imballo

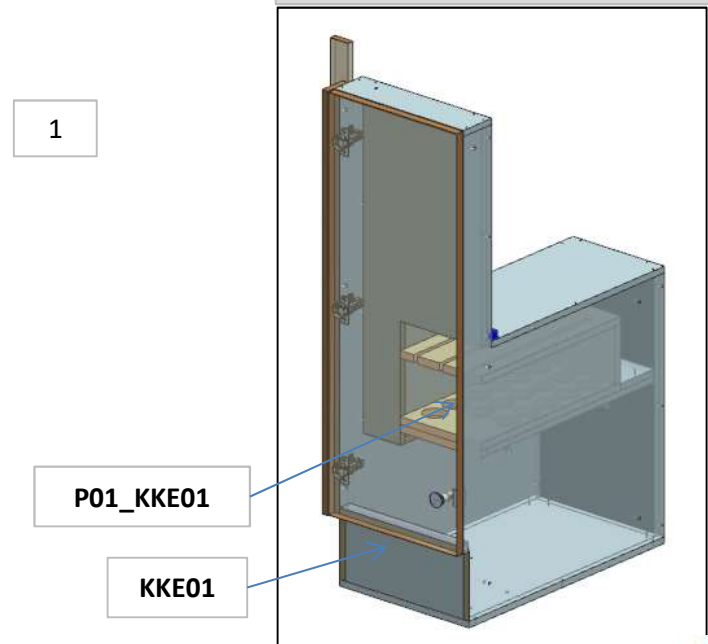

# AZ68F

DA MAT. 265 REV. 29-04-2024

LOCALE	CODICE	DESCRIZIONE COMPONENTE	FINITURA	Q.TA	OPERATORE
CUCINA A POPPA	AZ68F-R01_KKF01	STRUTTURA MURATA PLENUM	LASTRA CHIARA	13	Damiano

1 - L 143 x H 566 x sp 16mm  
 2 - L 1919 x H 326 x sp 16mm  
 3 - L 944 x H 244 x sp 16mm  
 4 - L 390 x H 485 x sp 32mm  
 5 - L 390 x H 163 x sp 32mm  
 6 - L 425 x H 405 x sp 32mm

8 - dia 32 x H 872mm  
 9 - dia 32 x H 405mm  
 10 - dia 32 x H 485mm  
 11 - dia 32 x H 80mm  
 12 - dia 32 x H 565mm  
 13 - L 944 x H 244 x sp 16

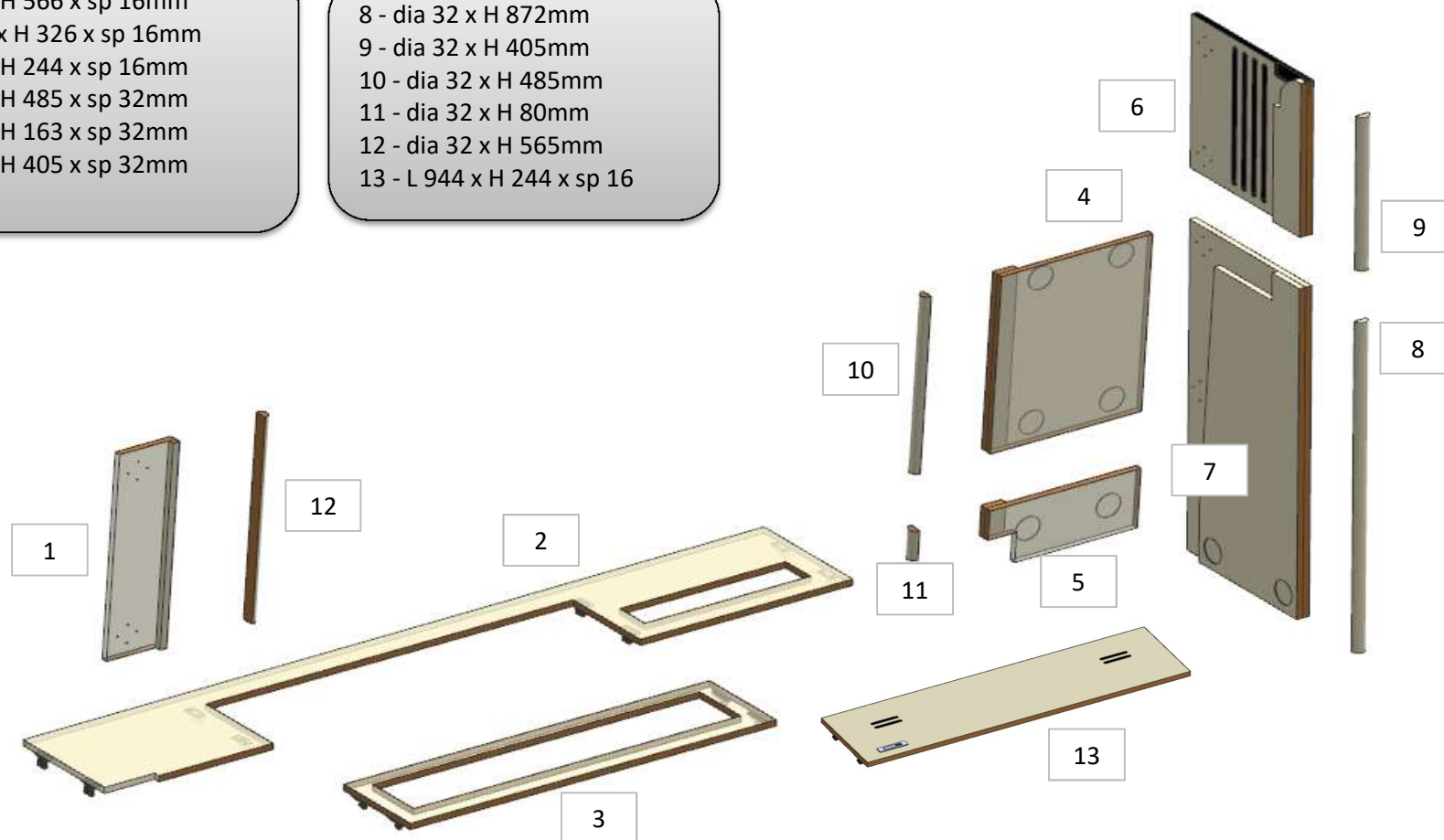

# AZ68F

DA MAT. 265 REV. 29-04-2024

LOCALE	CODICE	DESCRIZIONE COMPONENTE	FINITURA	Q.TA	OPERATORE
CUCINA A POPPA	AZ68F-R02_KKF01	STRUTTURA MURATA PLENUM	LASTRA TEAK	2	Damiano

- 1 - L 441 x H 33 x sp 6
- 2 - L 441 x H.33 x sp 6

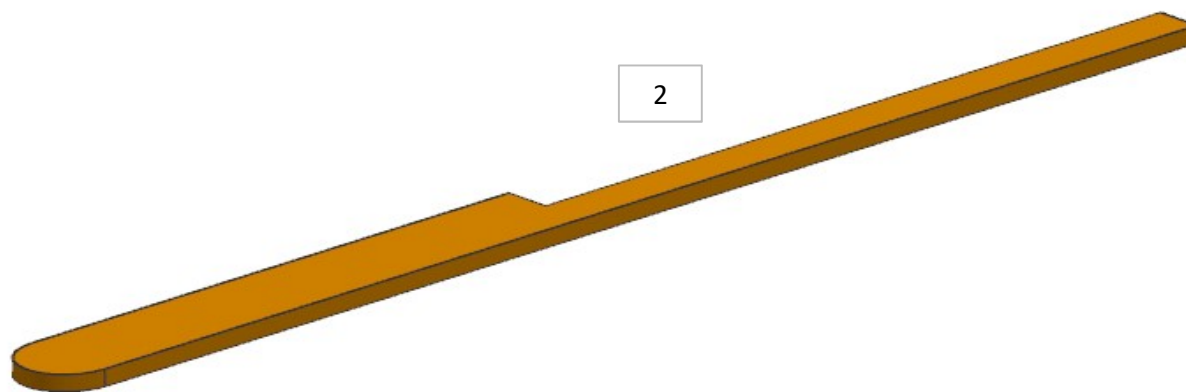
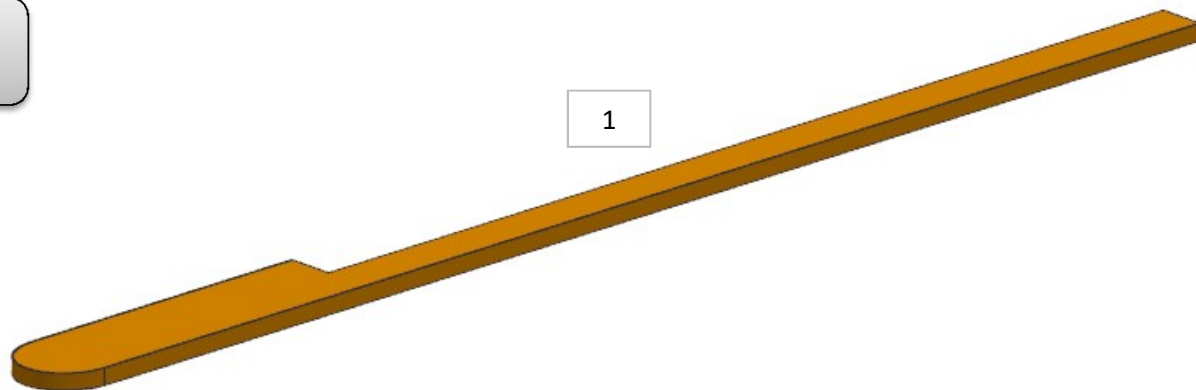

# AZ68F

DA MAT. 212

REV. 29-04-2024

LOCALE	CODICE	DESCRIZIONE COMPONENTE	FINITURA	Q.TA	OPERATORE
CUCINA A POPPA	AZ68F-R01_KKL01	RIV. GRADINO COPERTA	LASTRA CHIARA	1	Damiano

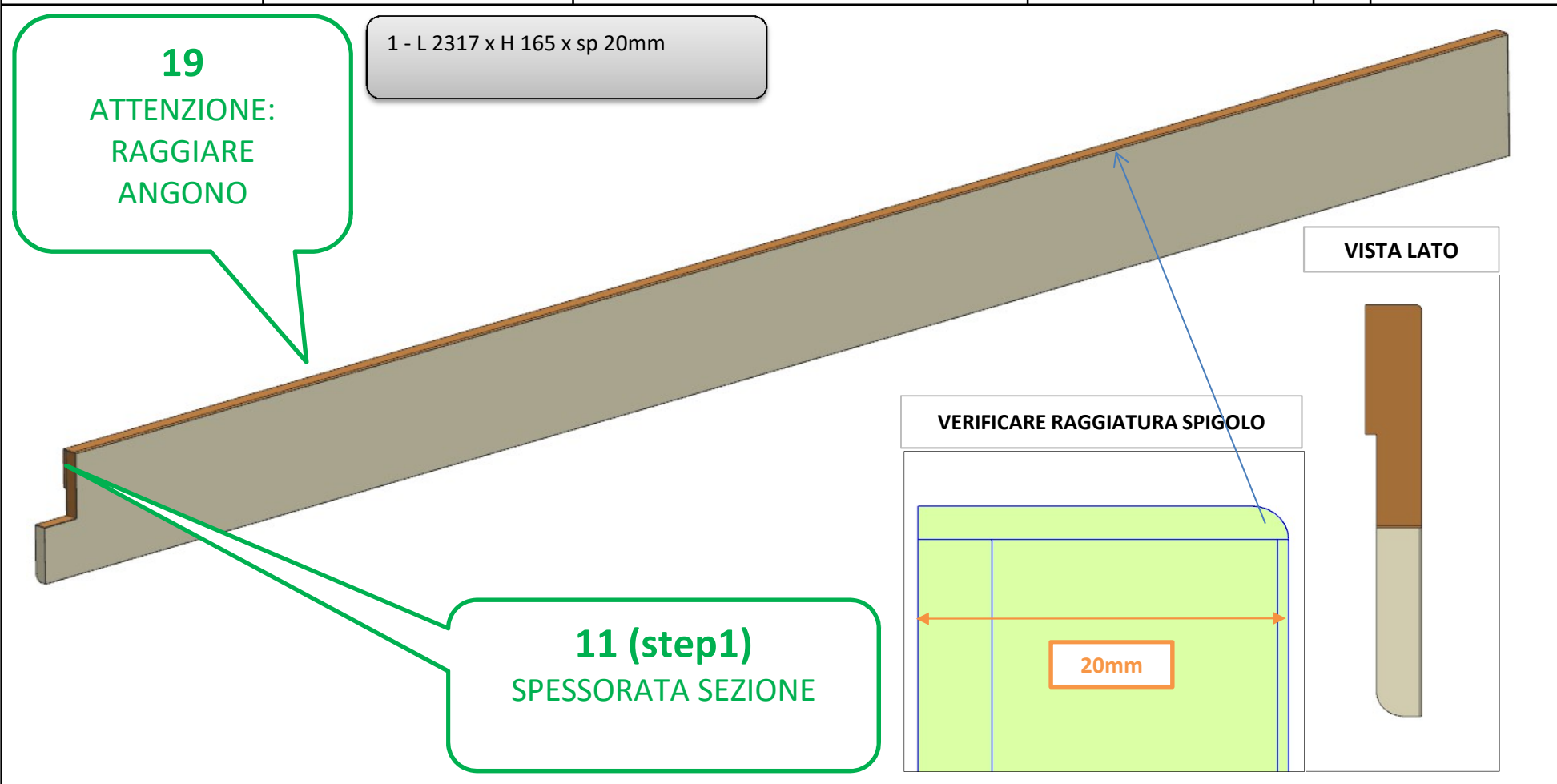

# AZ68F

DA MAT. 212 REV. 29-04-2024

LOCALE	CODICE	DESCRIZIONE COMPONENTE	FINITURA	Q.TA	OPERATORE
CUCINA A POPPA	AZ68F-R01_KKN01	PENISOLA POPPA SX	LASTRA CHIARA	6	Damiano

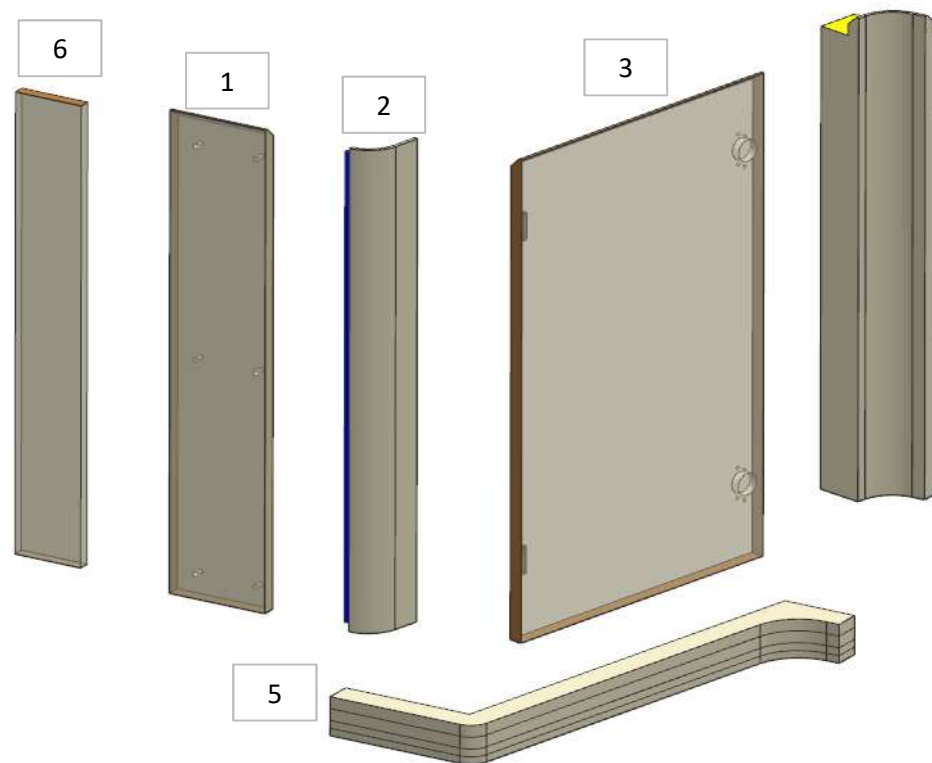

**4**  
MODIFICATA  
DIMENSIONE PEZZO  
N.6

**7**  
AGGIUNTI PZ. 5 e 6. 45°  
ANCHE SU MASSELLI

4

KKN01  
L01\_KKN01

ELEMENTO DA MONTARE con:  
KKN01  
L01\_KKN01

**ID 1415**  
LAMELLARE E  
LASTRARE ASSIEME  
PEZZI N.1 E 2

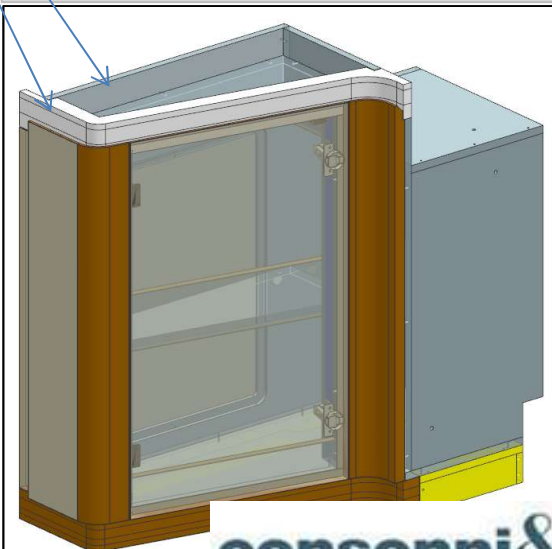

1 - L 149 x H 774 x sp 20 mm  
2 - SVILUPPO 109 x H 774 x 53mm  
3 - L 463 x H 774 x sp 20 mm

4 - L 126 x H 774 x 64 mm  
5 - L 640 x H 62,5 x 302 mm  
6 - L 102 x H 740 x sp 16 mm

# AZ68F

REV. 29-04-2024

LOCALE	CODICE	DESCRIZIONE COMPONENTE	FINITURA	Q.TA	OPERATORE
CUCINA A POPPA	AZ68F-R01_KKP01	OPT WINE COOLER	LASTRA CHIARA	2	Damiano

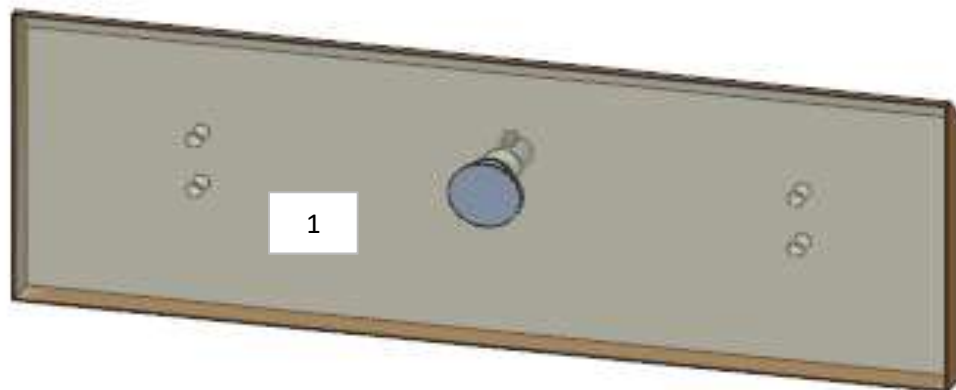

1 - L.461 x H 163 x sp 20  
2 - L.461 x H 32 x 71

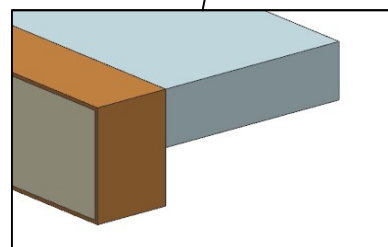
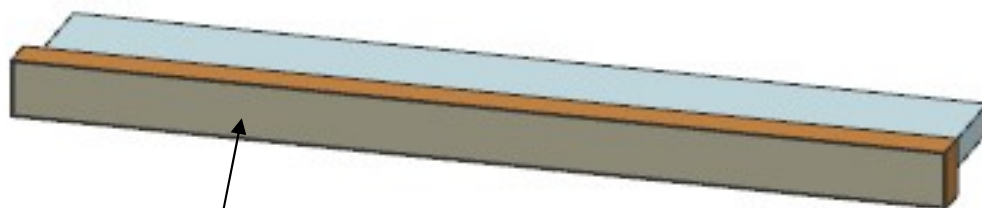

ELEMENTO DA MONTARE con:  
**KKP01**  
e spedire con un unico imballo

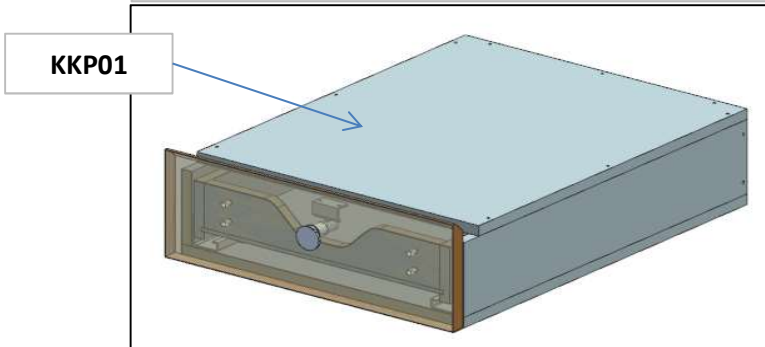

# AZ68F

REV. 29-04-2024

LOCALE	CODICE	DESCRIZIONE COMPONENTE	FINITURA	Q.TA	OPERATORE
CUCINA A POPPA	AZ68F-R01_KKQ01	OPT ICE MAKER	LASTRA CHIARA	1	Damiano

1 - L 461 x H.774 x sp 20

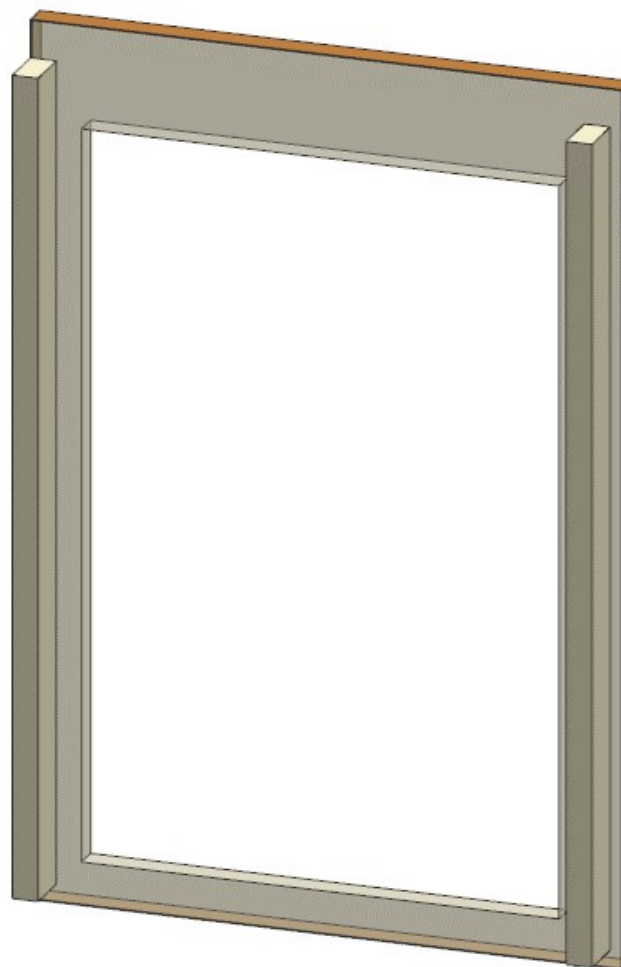

**consonni&c**