

AZ68F

REV. 03-10-2022

LOCALE	CODICE	DESCRIZIONE COMPONENTE	FINITURA	Q.TA	OPERATORE
CUCINA A POPPA	AZ68F-P01_KKA01	BASE CUCINA MURATA POPPA	FAGGIO	1	Damiano

1 - L.506 x H 523 x sp 19

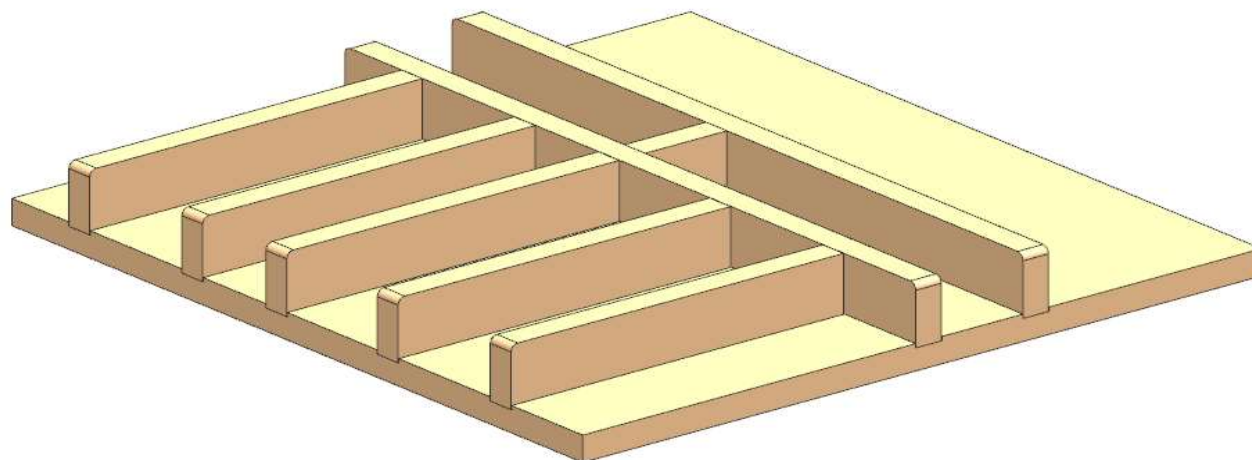

ELEMENTO DA MONTARE con:
R01_KKA01
L01_KKA01
KKA01
e spedire con un unico imballo

L01_KKA01
KKA01
R01_KKA01
R02_KKA01

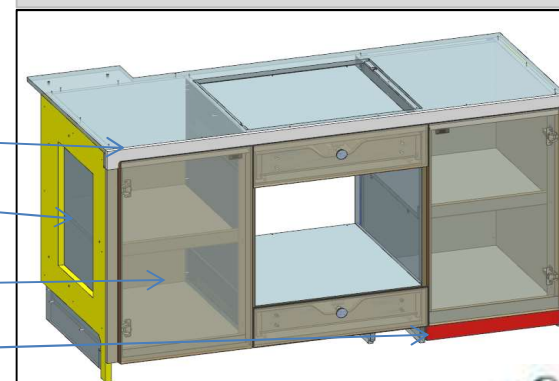

consonni&c

AZ68F

REV. 03-10-2022

LOCALE	CODICE	DESCRIZIONE COMPONENTE	FINITURA	Q.TA	OPERATORE
CUCINA A POPPA	AZ68F-P01_KKB01	BASE CUCINA CENTRONAVE	FAGGIO\ GOMMA	4	Damiano

TUTTI UGUALI : L.454 x H 277 x sp 19

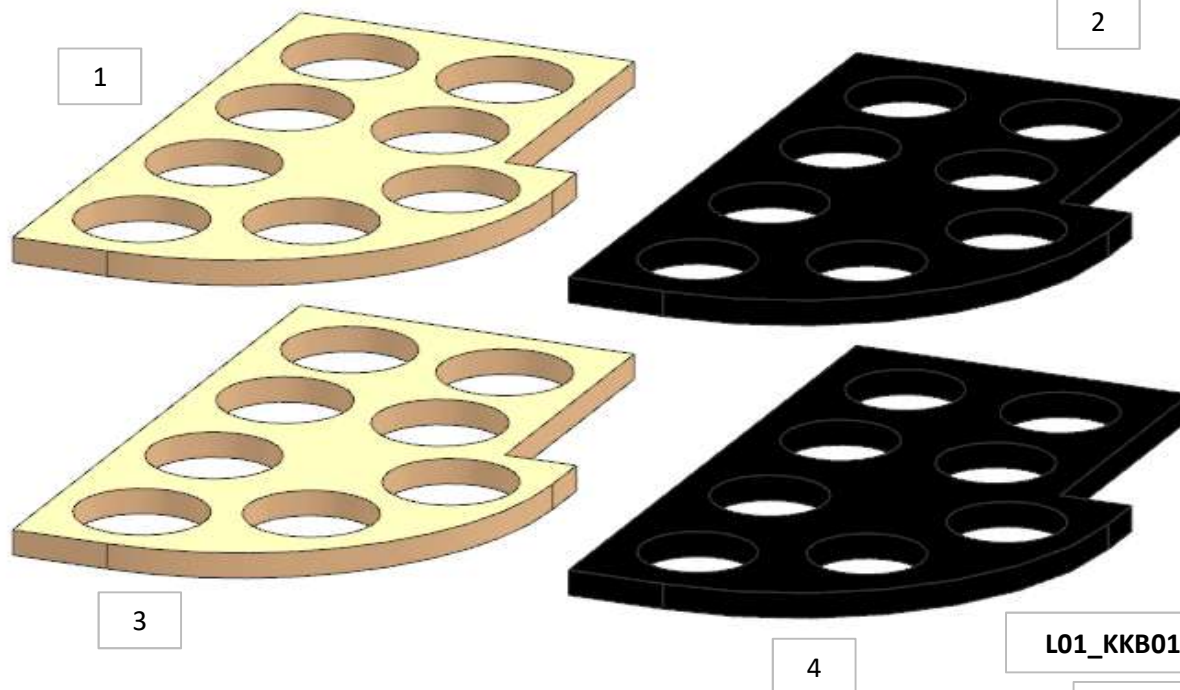

ELEMENTO DA MONTARE con:
R01_KKB01
L01_KKB01
KKB01
 e spedire con un unico imballo

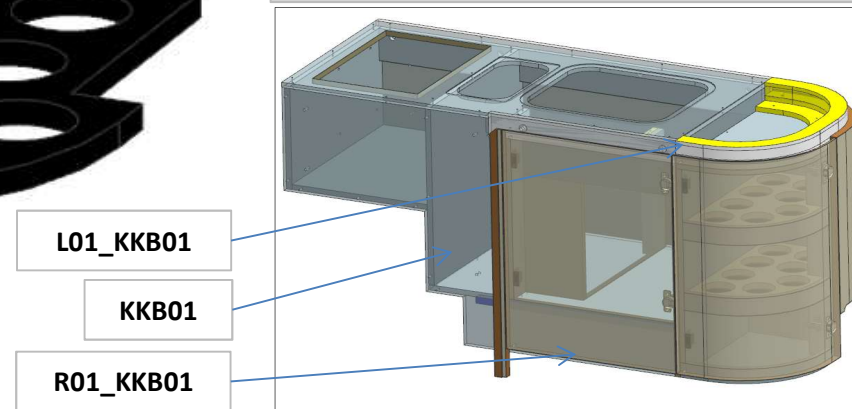

consonni&c

AZ68F

REV. 03-10-2022

LOCALE	CODICE	DESCRIZIONE COMPONENTE	FINITURA	Q.TA	OPERATORE
CUCINA A POPPA	AZ68F-P01_KKD01	CASSA FRIGO	LAMINATO NADIR	2	Damiano

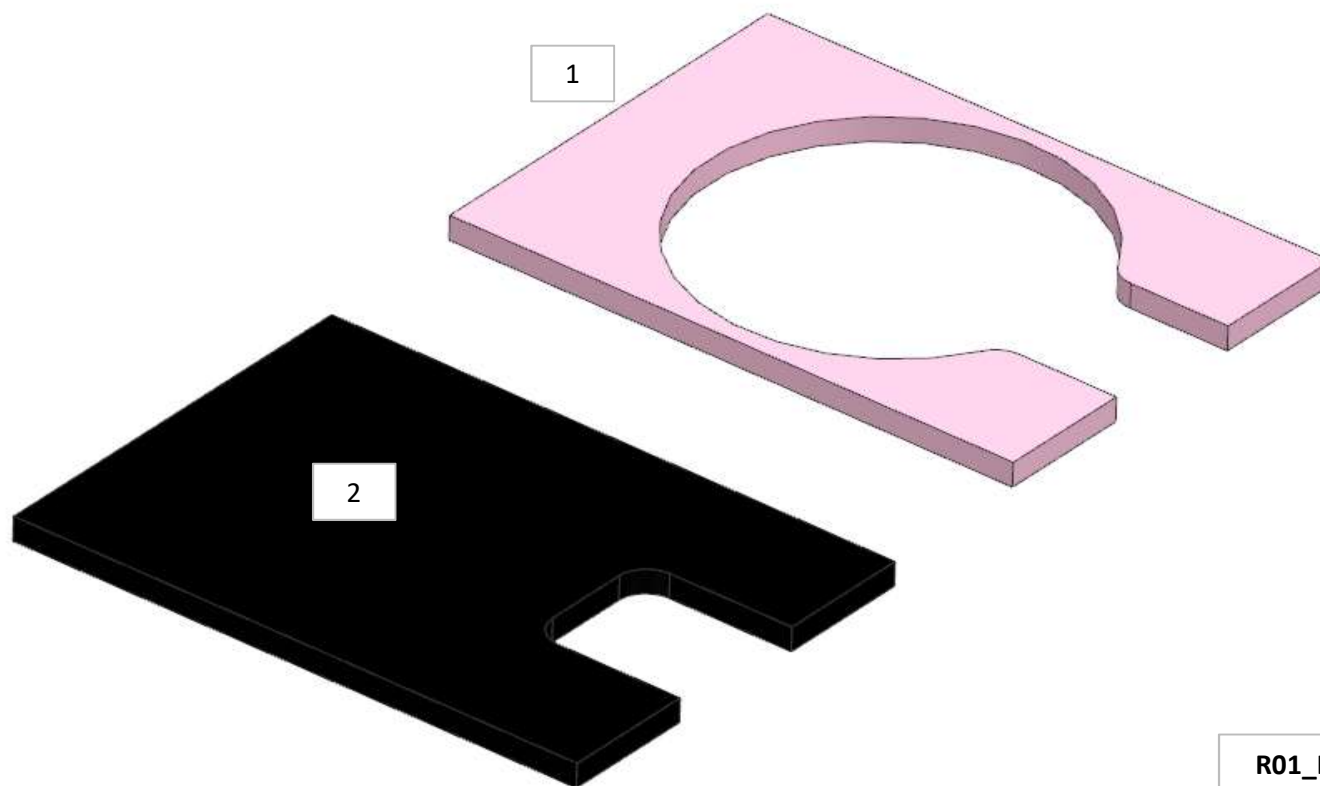

ELEMENTO DA
MONTARE con:
KKD01
R01_KKD01
e spedire con un unico

R01_KKD01
KKD01

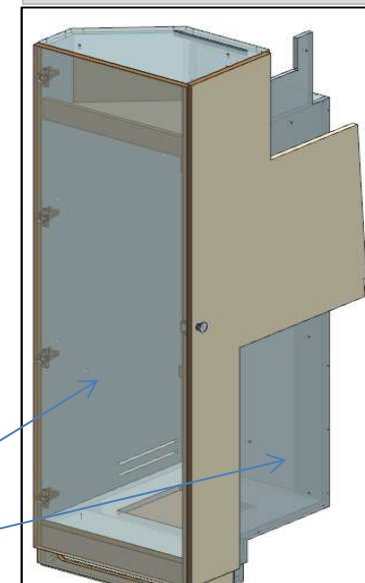

consonni&c

AZ68F

REV. 03-10-2022

LOCALE	CODICE	DESCRIZIONE COMPONENTE	FINITURA	Q.TA	OPERATORE
CUCINA A POPPA	AZ68F-P01_KKE01	MOBILE TERMINALE POPPA SX	FAGGIO	1	Damiano

1 - L.476 x H 179 x 240

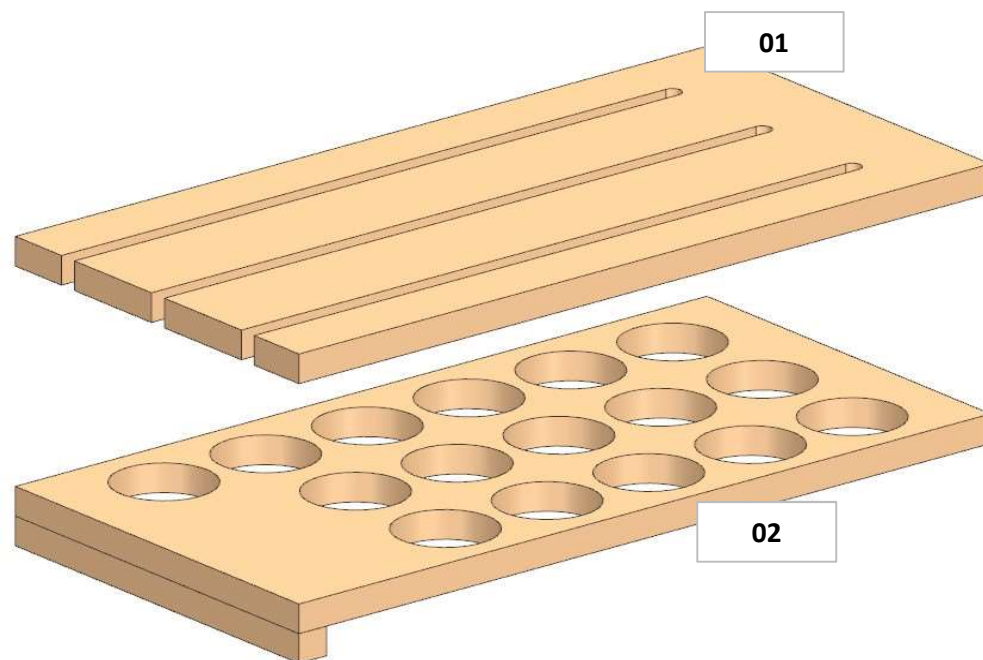

ELEMENTO DA MONTARE con:
R01_KKE01
KKE01
e spedire con un unico imballo

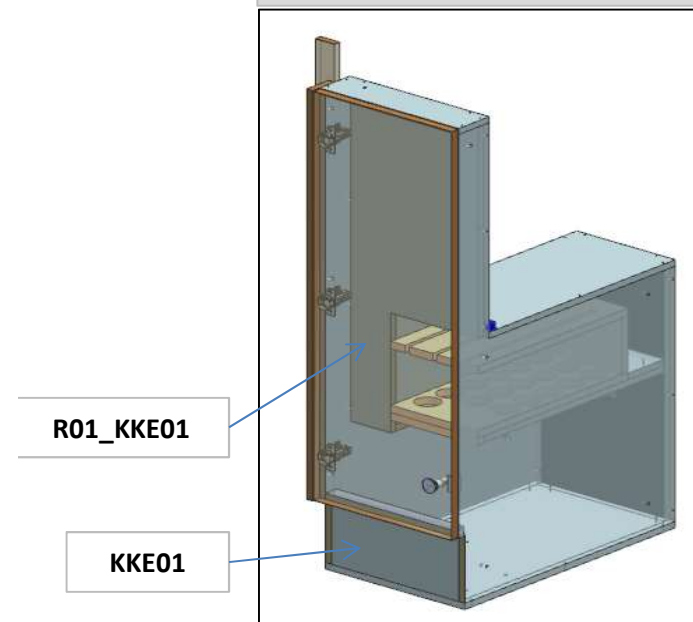

consonni&c