

AZ68F

DA MAT 265

REV. 29-04-2024

LOCALE	CODICE	DESCRIZIONE COMPONENTE	FINITURA	Q.TA	OPERATORE
CABINA ARMATORE	AZ68F-R01_AA01	STRUTTURE BASSE A MURATA SX	LASTRA CHIARA	7	Damiano

MODIFICATA
DIMENSIONE PEZZO 5

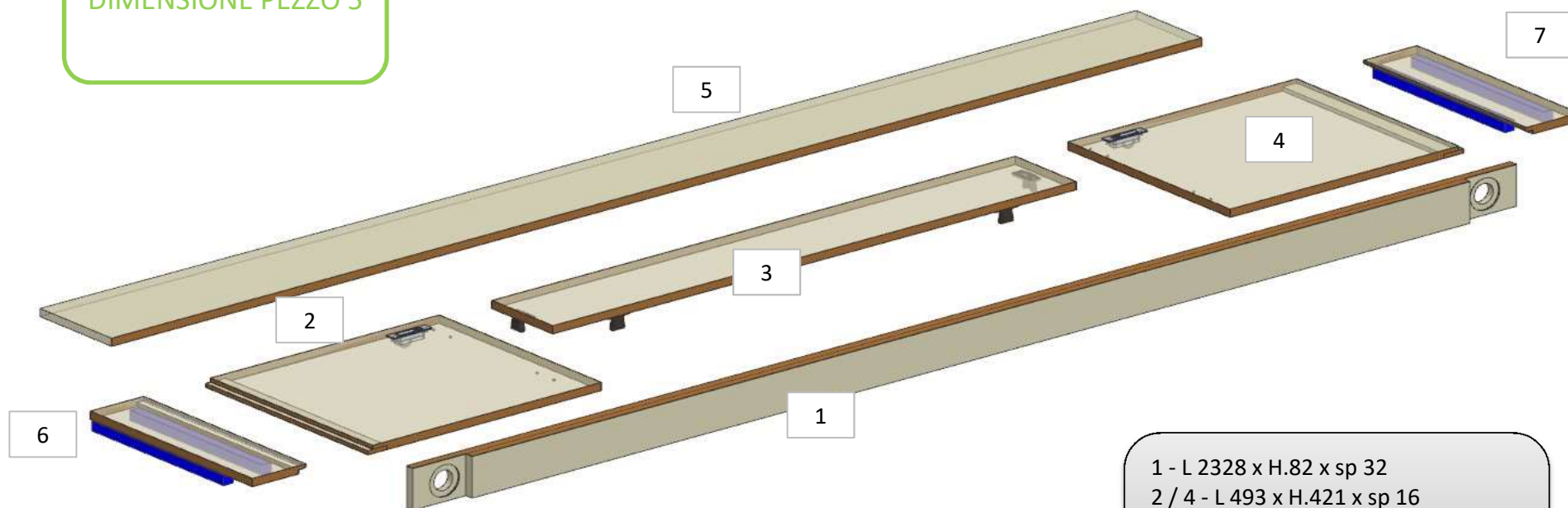

- 1 - L 2328 x H.82 x sp 32
- 2 / 4 - L 493 x H.421 x sp 16
- 3 - L 1105 x H.158 x sp 16
- 5 - L 2300 x H.185/170 x sp 16
- 6 / 7 - L 421 x H 113.5 x sp 16

consonni&c

AZ68F

DA MAT. 265 REV. 29-04-2024

LOCALE	CODICE	DESCRIZIONE COMPONENTE	FINITURA	Q.TA	OPERATORE
CABINA ARMATORE	AZ68F-R01_AB01	STRUTTURA TV A MURATA SX	LASTRA CHIARA	1	Damiano

1 - L.1102 x H.259 x sp 16

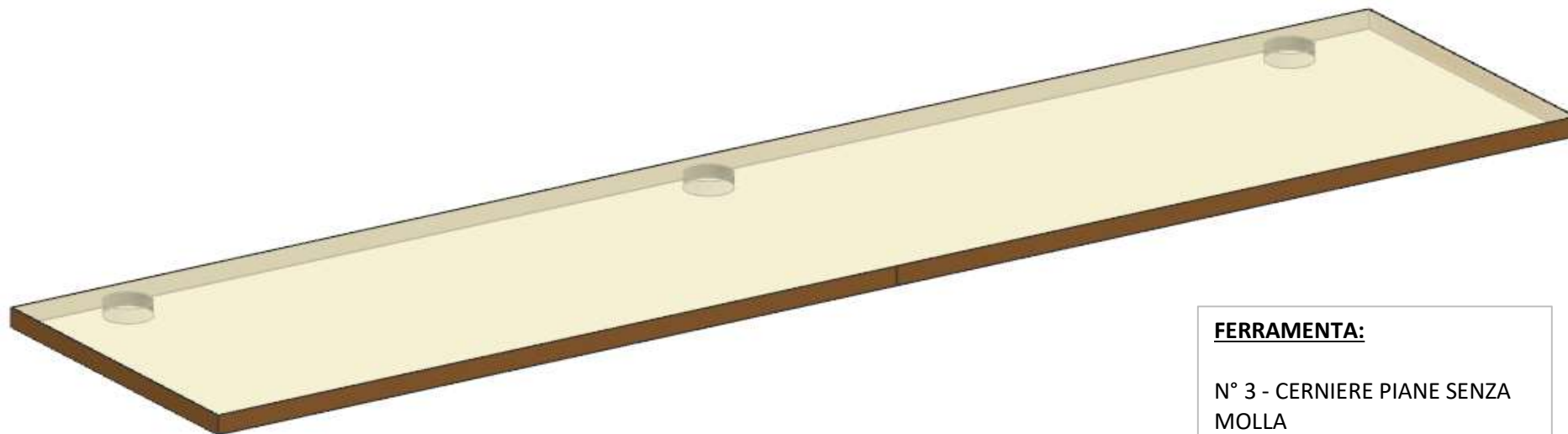

FERRAMENTA:

N° 3 - CERNIERE PIANE SENZA
MOLLA
N° 3 - BASETTE H6
N° 12 - ANKOR BORGHI
N° 8 - VITI 6MA X 25 TB
N° 7 - FITLOCK MASCHIO
N° 3 - FITLOCK FEMMINA
N° 2 - KEKU PARTE TELAIO

AZ68F

DA MAT. 265 REV. 29-04-2024

LOCALE	CODICE	DESCRIZIONE COMPONENTE	FINITURA	Q.TA	OPERATORE
CABINA ARMATORE	AZ68F-R01_AC01	PLENUM A.C. MURATA SX	LASTRA CHIARA	2	Damiano

ELEMENTO DA AVVITARE SOLO PUNTATO

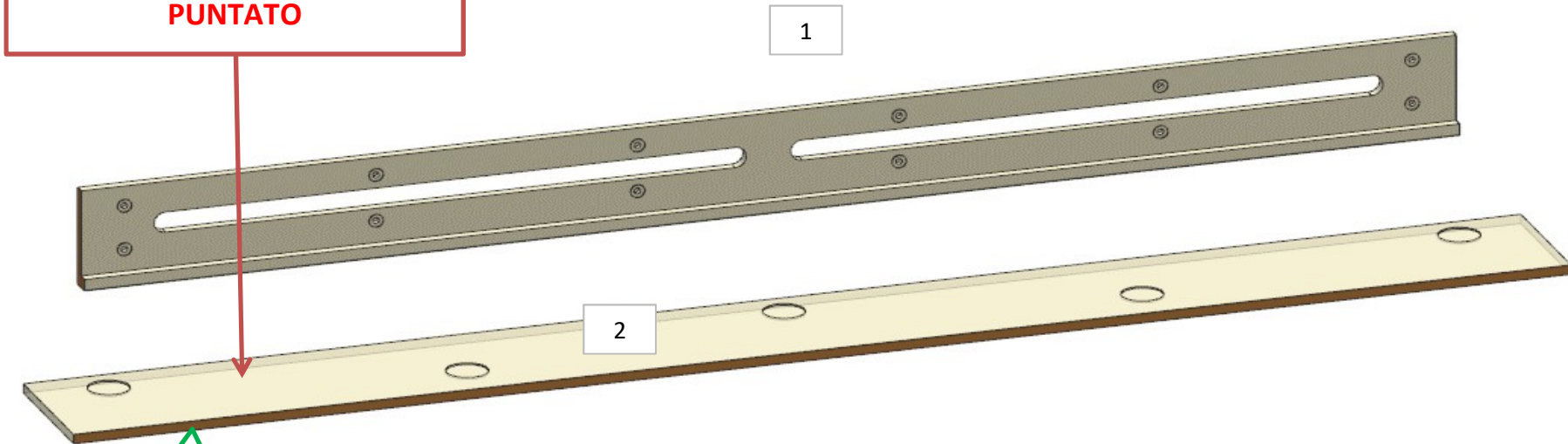

da mat.207
MODIFICATE DIMENSIONI
2301x230x16mm

- 1 - L.2105 x H.168 x 32
- 2 - L.2301 x H.230 x sp. 16

AZ68F

DA MAT. 207 REV. 29-04-2024

LOCALE	CODICE	DESCRIZIONE COMPONENTE	FINITURA	Q.TA	OPERATORE
CABINA ARMATORE	AZ68F-R01_AD01	STRUTTURA ALTA TEATRINO MURATA SX	LASTRA CHIARA	2	Damiano

- 1 - L.2301 x H.388/373 x sp 16
- 2 - L.2301 x H.132 x sp 16

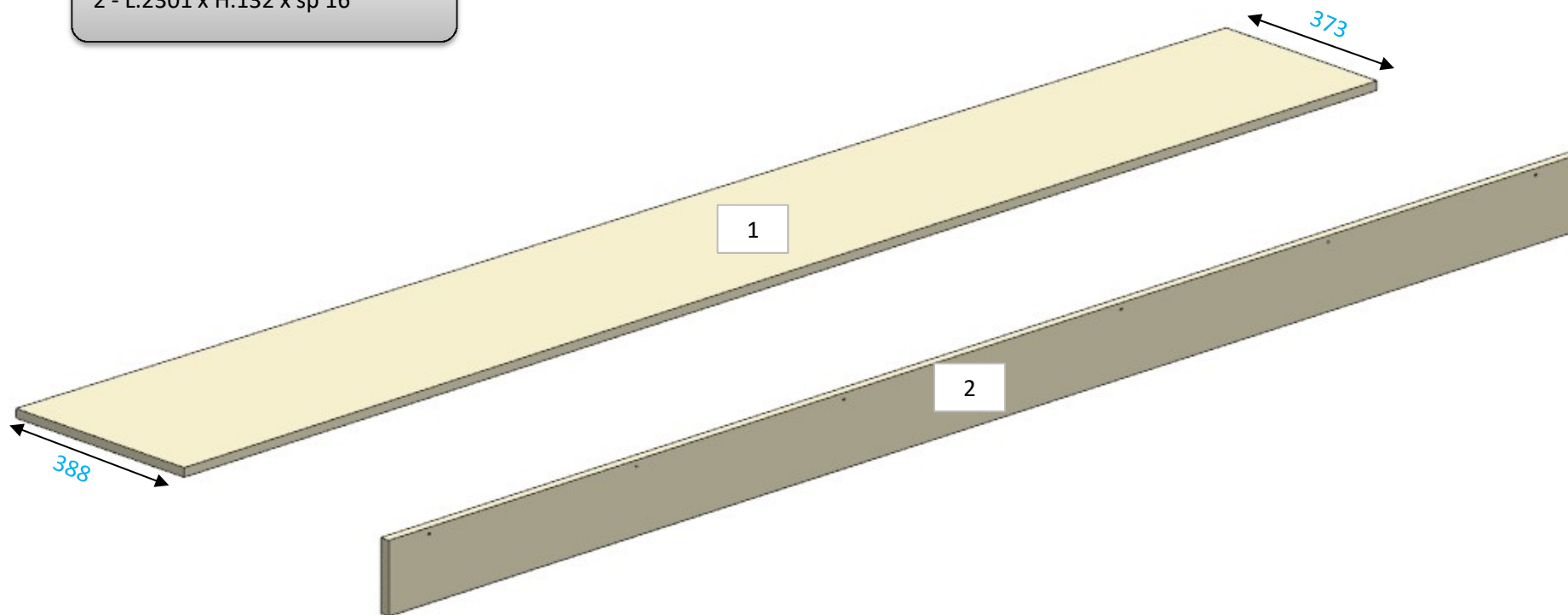

AZ68F

DA MAT 233

REV. 29-04-2024

LOCALE	CODICE	DESCRIZIONE COMPONENTE	FINITURA	Q.TA	OPERATORE
CABINA ARMATORE	AZ68F-R01_AE01	GRADINO SX	LASTRA CHIARA	4	Damiano

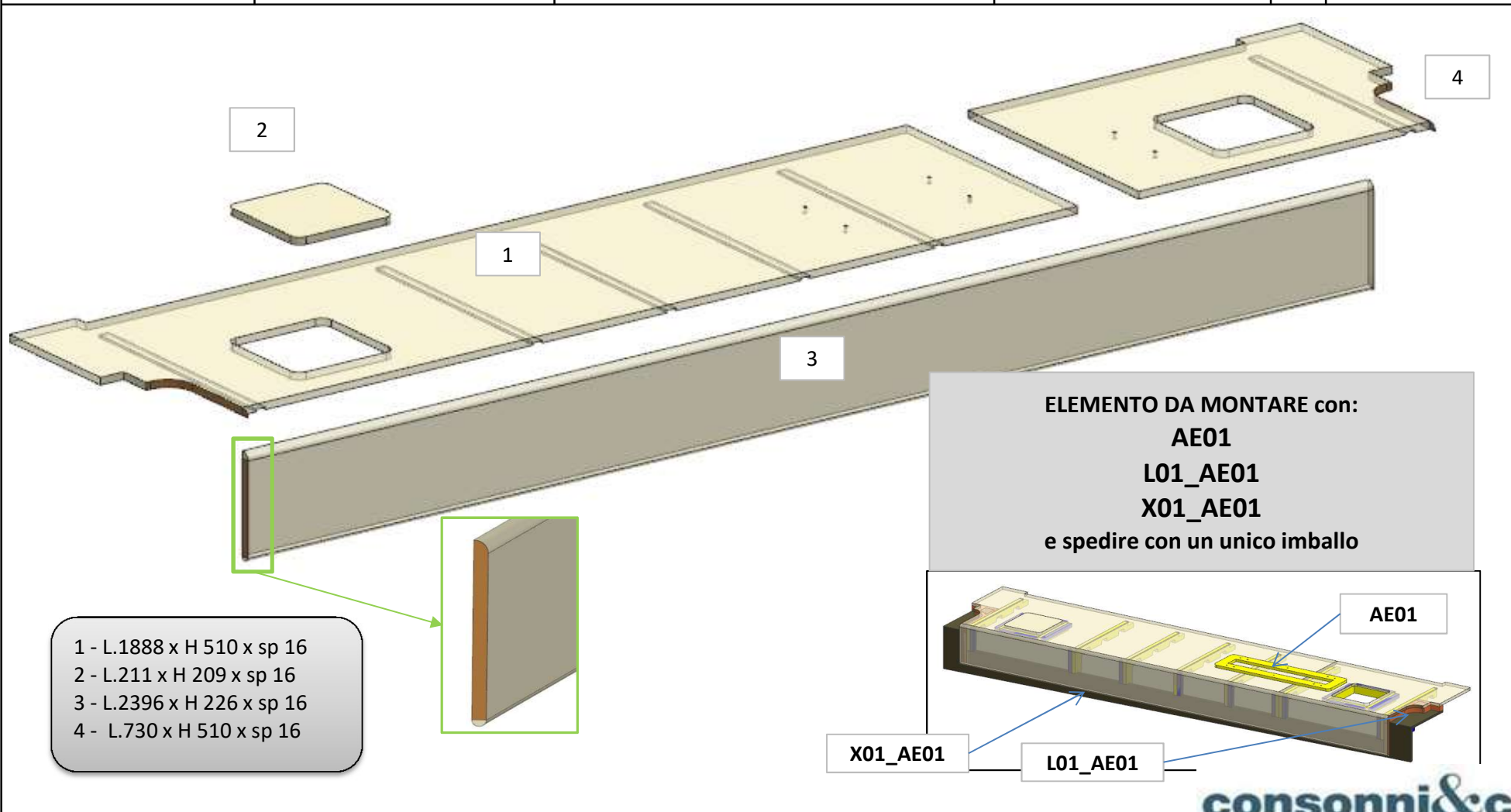

AZ68F

DA MAT. 207 REV. 29-04-2024

LOCALE	CODICE	DESCRIZIONE COMPONENTE	FINITURA	Q.TA	OPERATORE
CABINA ARMATORE	AZ68F-R01_AF01	RIVESTIMENTO POPPA SX	LASTRA CHIARA	3	Damiano

1 - L.394 x H.1956 x sp 16
2 - L.365 x H.1047 x sp 16
3 - dia.32 x H.797mm

da mat.207
RIMOSSO UN PEZZO E
SPOSTATO NELLA
PORTA P08

da mat.207
AGGIUNTI
ABBASSAMENTI

FERRAMENTA:

N° 14 - FITLOCK MASCHIO
N° 2 - FITLOCK FEMMINA

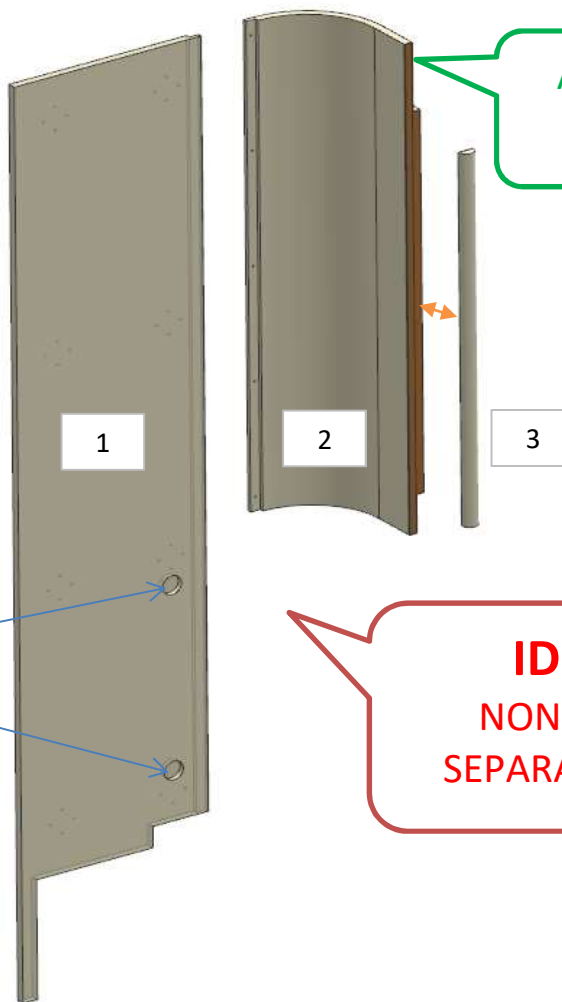

AGGIUNTO
BORDO

ELEMENTO DA
MONTARE con:
L01_AF01
e spedire con un
unico imballo

ID 1673
NON SPEDIRE
SEPARATAMENTE

L01_AF01

AZ68F

REV. 29-04-2024

LOCALE	CODICE	DESCRIZIONE COMPONENTE	FINITURA	Q.TA	OPERATORE
CABINA ARMATORE	AZ68F-R01_AG01	RIVESTIMENTO PRUA SX	LASTRA CHIARA	3	Damiano

- 1 - L.505 x H.1955 x sp 16
- 2 - L.365 x H.1047 x sp 16
- 3 - dia.32 x H.797mm

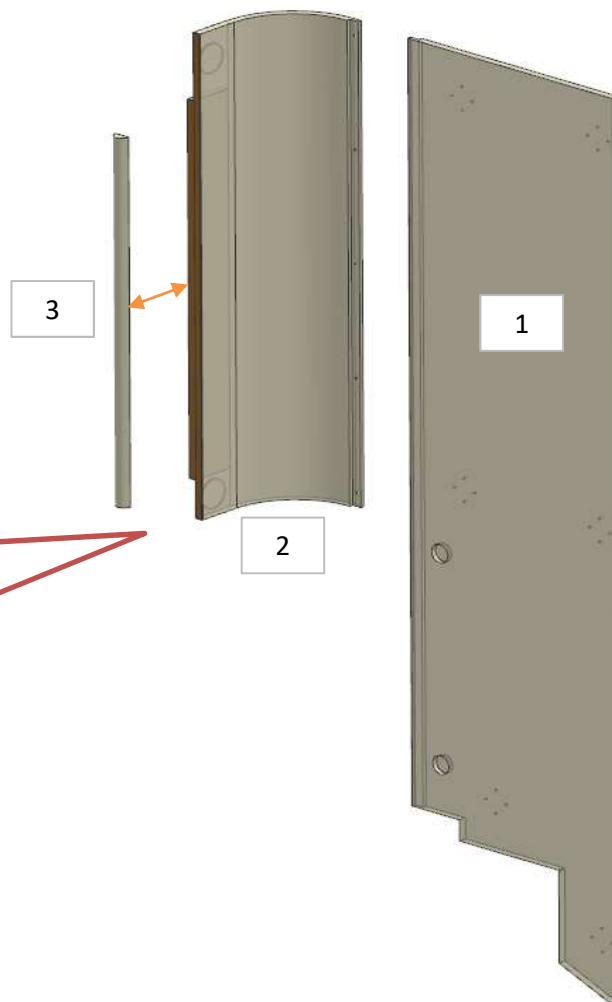

ID 1673
NON SPEDIRE
SEPARATAMENTE

FERRAMENTA:

- N° 12 - FITLOCK MASCHIO
- N° 2 - FITLOCK FEMMINA

ELEMENTO DA
MONTARE con:
L01_AF01
e spedire con un
unico imballo

L01_AG01

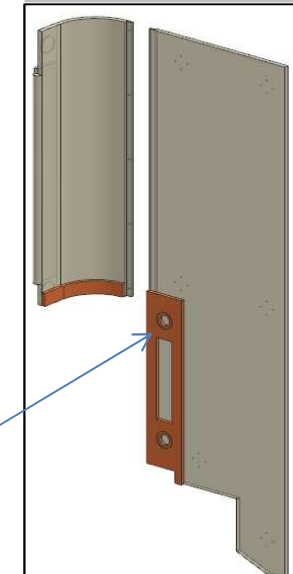

consonni&c

AZ68F

DA MAT. 233 REV. 29-04-2024

LOCALE	CODICE	DESCRIZIONE COMPONENTE	FINITURA	Q.TA	OPERATORE
CABINA ARMATORE	AZ68F-R01_AH01	CASSETTIERA SX	LASTRA CHIARA	2	Damiano

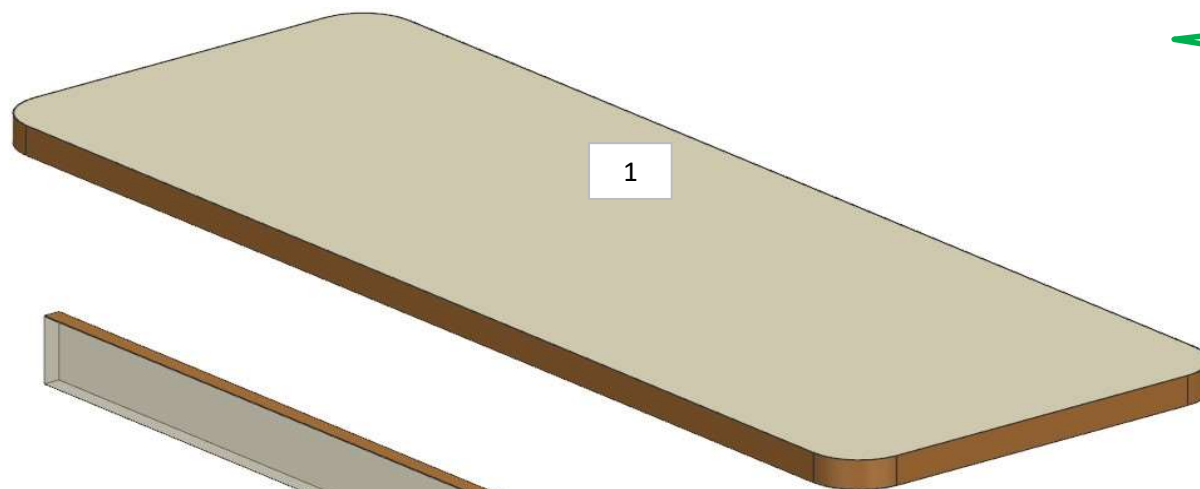

1

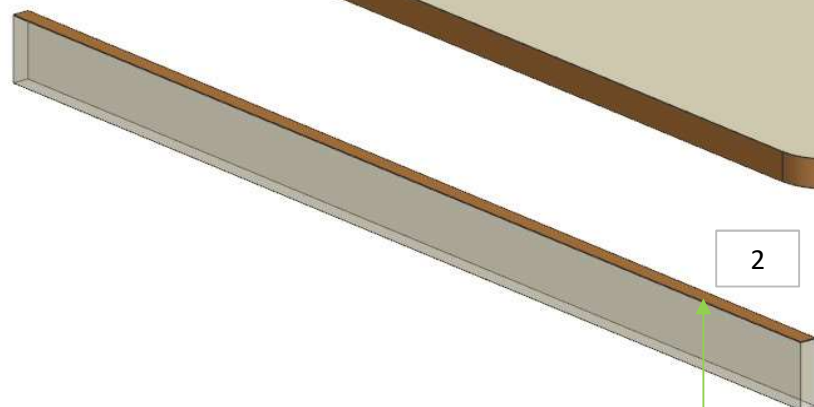

2

BORDO
LASTRA

1 - L..1150 x H.416 x sp 30
2 - L..1050 x H.70 x sp 16

243
RIMOSSA ASOLA TOP

ELEMENTO DA MONTARE con:
AH01
L01_AH01
L02_AH01
e spedire con un unico imballo

AH01

L01_AH01

L02_AH01

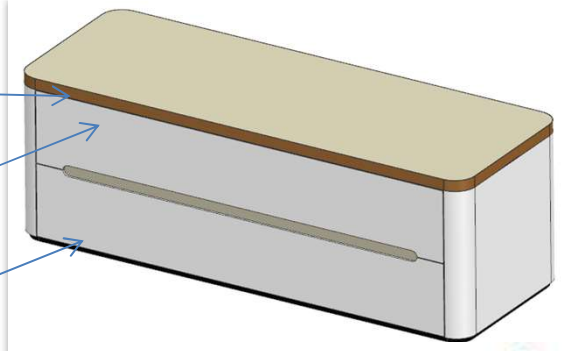

AZ68F

DA MAT. 233 REV. 29-04-2024

LOCALE	CODICE	DESCRIZIONE COMPONENTE	FINITURA	Q.TA	OPERATORE
CABINA ARMATORE	AZ68F-R01_AI01	PANNELLI FIN. VERT. SX POPPA E PRUA	LASTRA CHIARA	3	Damiano

1 - L. 664 x H 965 x sp 16
2 - L. 614 x H 965 x sp 16

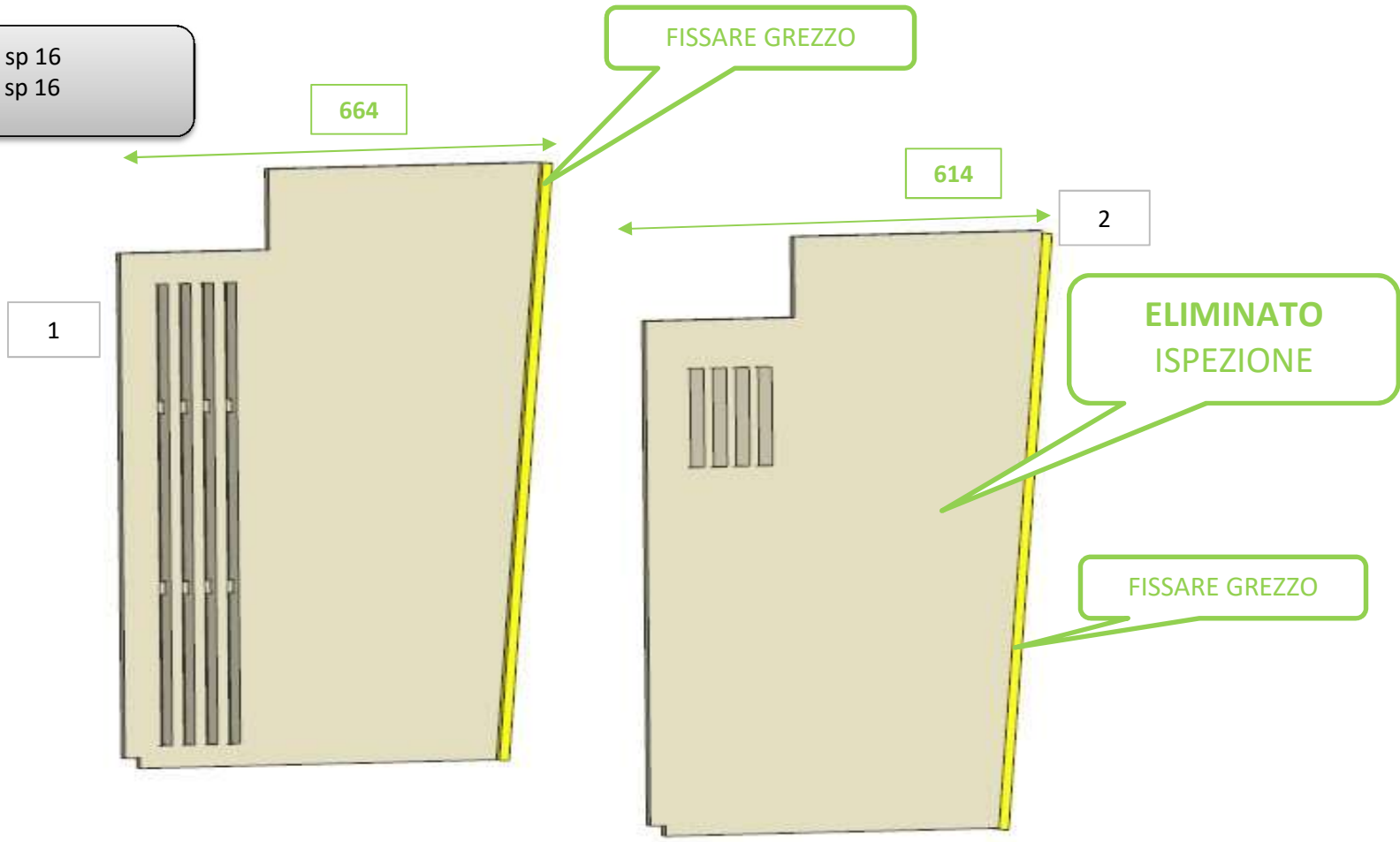

AZ68F

DA MAT. 233 REV. 29-04-2024

LOCALE	CODICE	DESCRIZIONE COMPONENTE	FINITURA	Q.TA	OPERATORE
CABINA ARMATORE	AZ68F-R01_AL01	ARMADIO DX POPPA	LASTRA CHIARA	3	Damiano

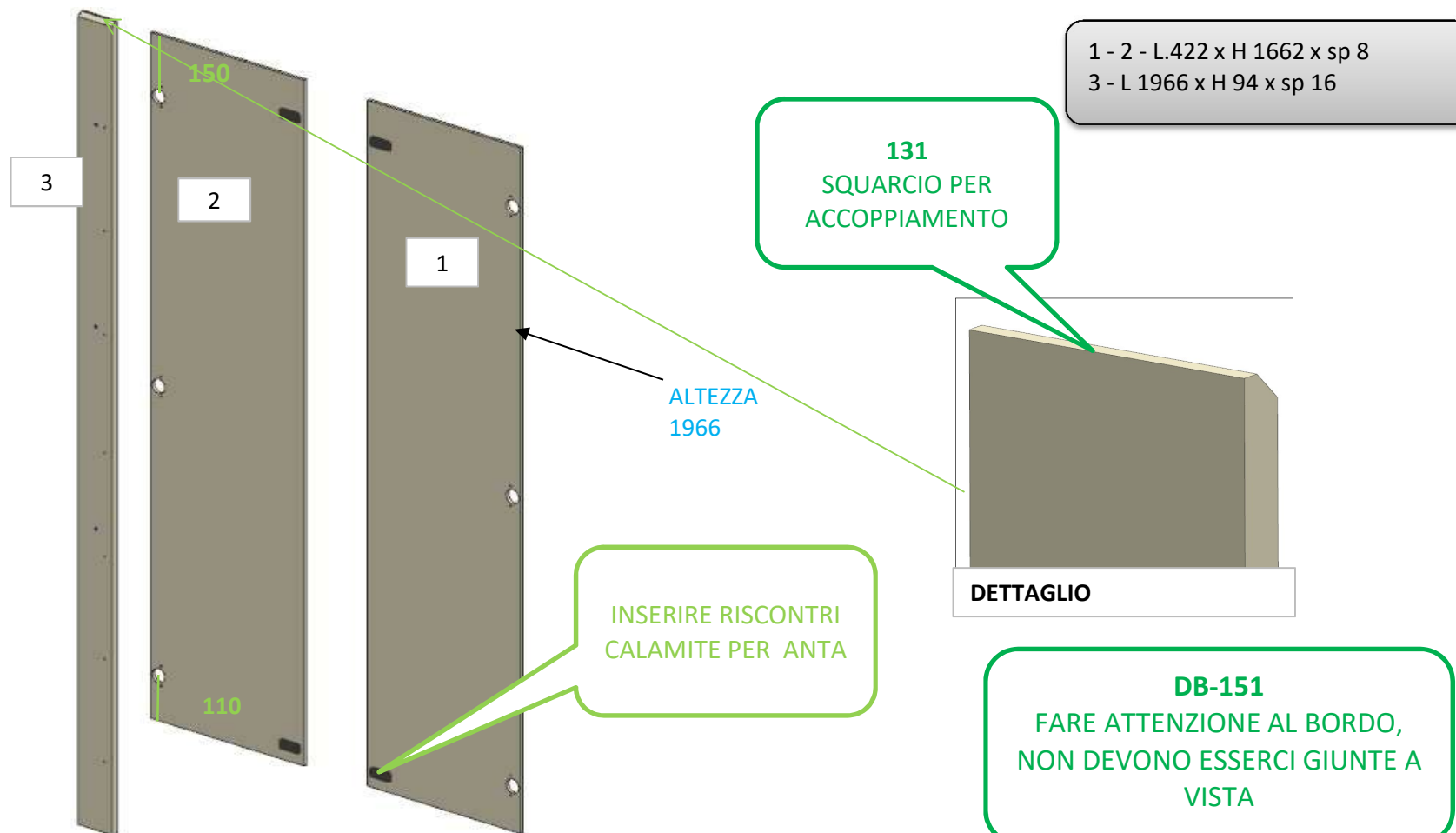

AZ68F

DA MAT. 233 REV. 29-04-2024

LOCALE	CODICE	DESCRIZIONE COMPONENTE	FINITURA	Q.TA	OPERATORE
CABINA ARMATORE	AZ68F-R01_AM01	STRUTTURA DX ANGOLO POPPA	LASTRA CHIARA	5	Damiano

- 1 - L 460 x H.1700 x sp 16
- 2 - L 293 x H.1080 x sp 16
- 3 - L 477 x H.1080 x sp 16
- 4 - L 280 x H.978 x sp 16
- 5 - dia.32 x H.805mm

FISSARE GREZZO

VERIFICARE SPALLETTA + FORI

METTERE BORDO

CURVATINO L. 805

FISSARE GREZZO

ELEMENTO DA MONTARE con:
L01_AM01
e spedire con un unico imballo

FERRAMENTA:
N° 16 - FITLOCK MASCHIO
N° 18 - FITLOCK FEMMINA
N° 14 - BUSSOLA ZAMA 6MA

ID 1673
NON SPEDIRE SEPARATAMENTE

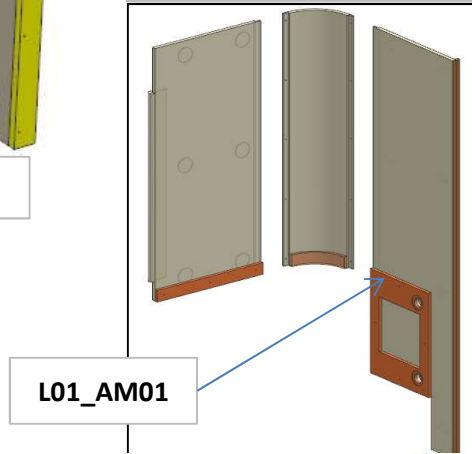

AZ68F

DA MAT. 207 REV. 29-04-2024

LOCALE	CODICE	DESCRIZIONE COMPONENTE	FINITURA	Q.TA	OPERATORE
CABINA ARMATORE	AZ68F-R01_AN01	STRUT. ALTA TEATRINO MURATA DX	LASTRA CHIARA	2	Damiano

1 - L.2307 x H 192 x sp 32
2 - L.2276 x H 266 x sp 16

MODIFICATA
LUNGHEZZA =2179

1

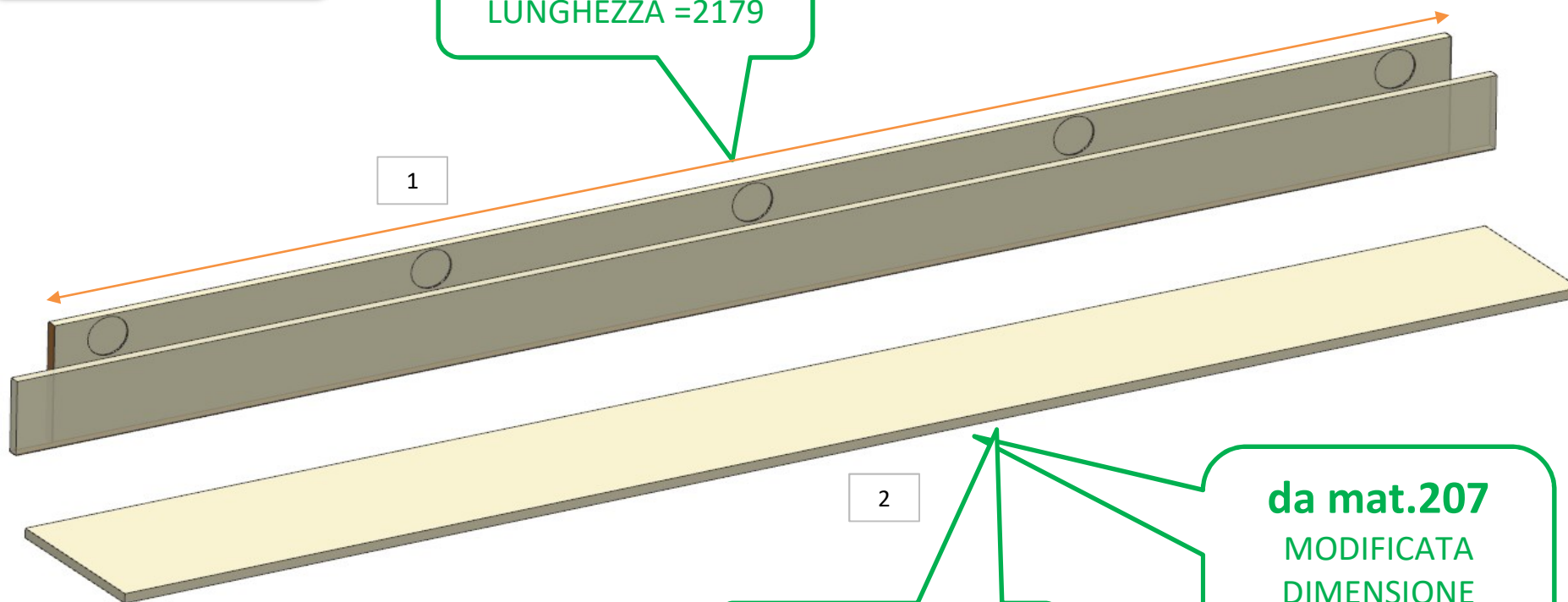

2

METTERE BORDO

da mat.207
MODIFICATA
DIMENSIONE
2276x266x16mm

consonni&c

AZ68F

DA MAT. 203 REV. 29-04-2024

LOCALE	CODICE	DESCRIZIONE COMPONENTE	FINITURA	Q.TA	OPERATORE
CABINA ARMATORE	AZ68F-R01_AO01	STRUTTURA BASSA A MURATA DX	LASTRA CHIARA	2	Damiano

1 - L.2276 x H.203 x sp 16
2 - L.2308 x H.82 x 32

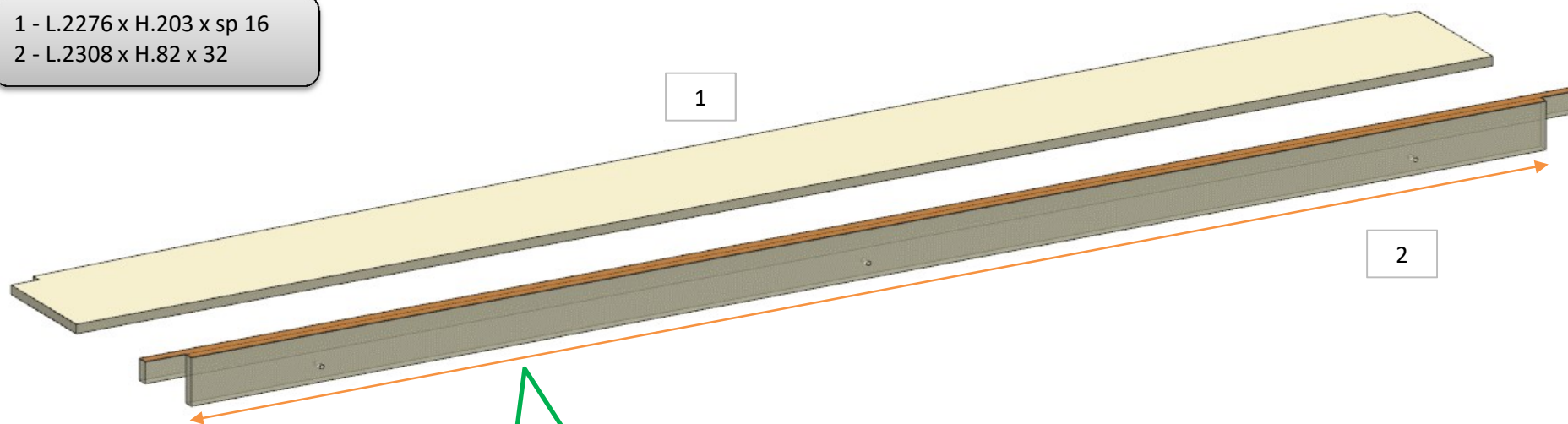

MODIFICATA
LUNGHEZZA =2179

ELEMENTO DA MONTARE con:
L01_AO01
e spedire con un unico imballo

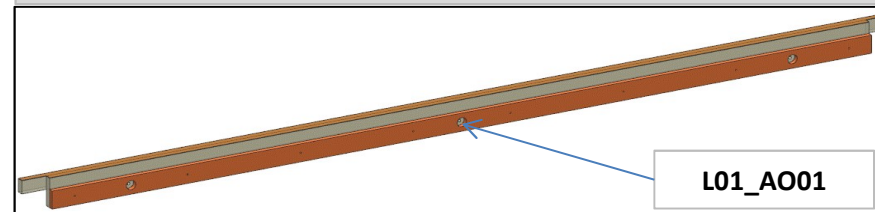

AZ68F

DA MAT. 207 REV. 29-04-2024

LOCALE	CODICE	DESCRIZIONE COMPONENTE	FINITURA	Q.TA	OPERATORE
CABINA ARMATORE	AZ68F-R01_AP01	STRUTTURA DX ANGOLO PRUA	LASTRA CHIARA	5	Damiano

- 1 - L 460 x H 1701 x sp 16
- 2 - L 293 x H 1080 x sp 16
- 3 - L 318 x H 1080 x sp 16
- 4 - L 265 x H 978 x sp 16
- 5 - dia.32 x H. 805

VERIFICARE
PRESENZA FORI

NON C'è LA
SPALLETTA

ID 1673
NON SPEDIRE
SEPARATAMENTE

FERRAMENTA:

- N° 24 - FITLOCK MASCHIO
- N° 10 - FITLOCK FEMMINA
- N° 4 - BUSSOLA ZAMA 6MA

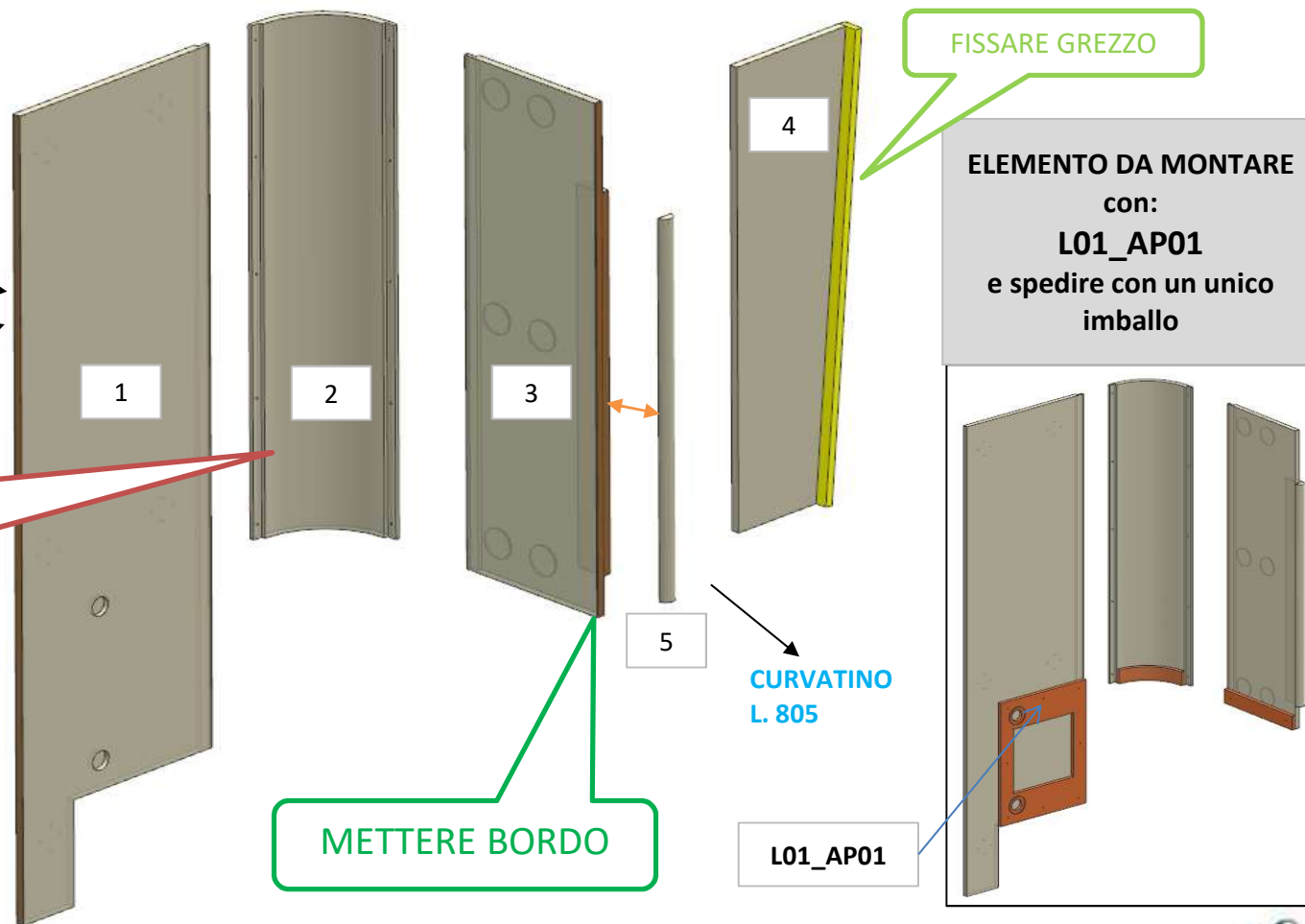

AZ68F

REV. 29-04-2024

LOCALE	CODICE	DESCRIZIONE COMPONENTE	FINITURA	Q.TA	OPERATORE
CABINA ARMATORE	AZ68F-R01_AR01	COMODINO POPPA	LASTRA CHIARA	4	Damiano

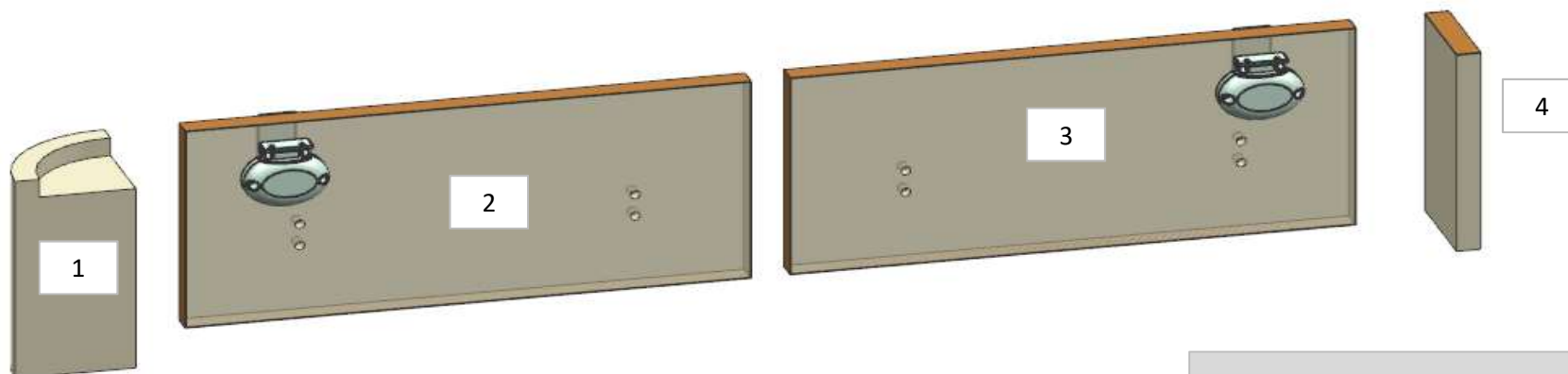

ELEMENTO DA MONTARE con:
AR01
L01_AR01
L02_AR01
 e spedire con un unico imballo

1 - L 100 x H189 x 100
 2 - 3 - L 469 x H189 x sp. 20
 4 - L 101 x H189 x sp. 20

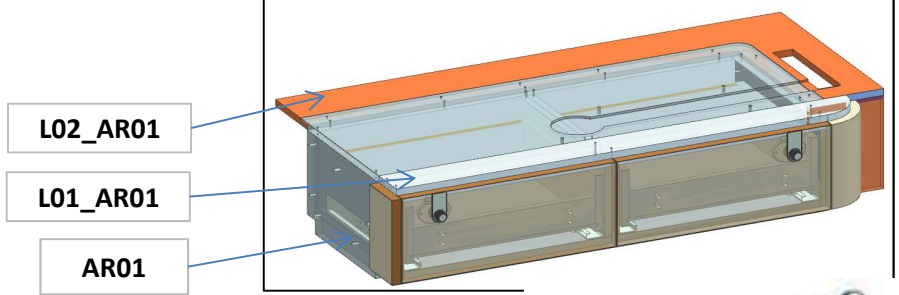

AZ68F

REV. 29-04-2024

LOCALE	CODICE	DESCRIZIONE COMPONENTE	FINITURA	Q.TA	OPERATORE
CABINA ARMATORE	AZ68F-R01_AS01	COMODINO PRUA	LASTRA CHIARA	3	Damiano

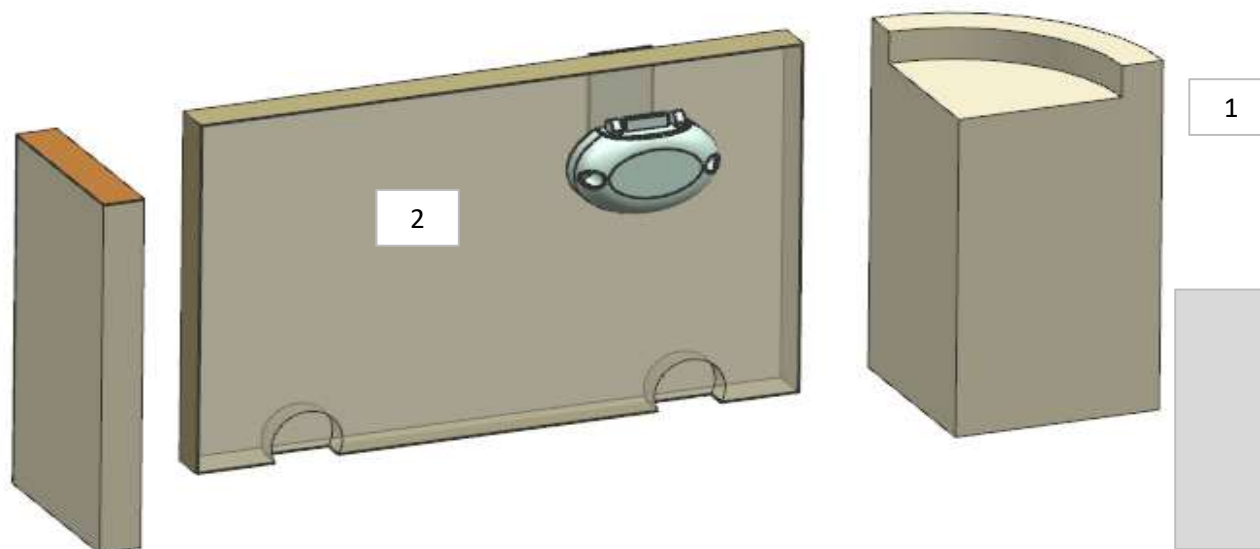

3

1

2

ELEMENTO DA MONTARE con:
AS01
L01_AS01
L02_AS01
e spedire con un unico imballo

1 - L 100 x H189 x 101
 2 - L 295 x H189 x sp. 20
 3 - L 101 x H189 x sp. 20

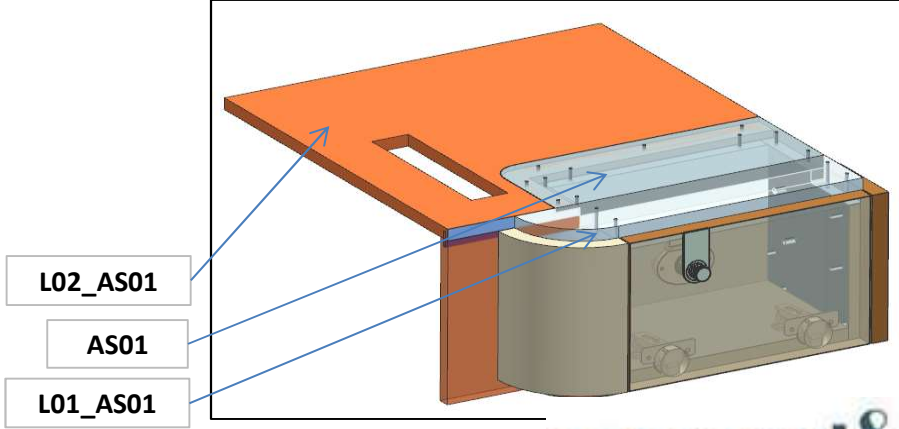

L02_AS01

AS01

L01_AS01

AZ68F

DA MAT. 233 REV. 29-04-2024

LOCALE	CODICE	DESCRIZIONE COMPONENTE	FINITURA	Q.TA	OPERATORE
CABINA ARMATORE	AZ68F-R01_AT01	ARMADIO PRUA	LASTRA CHIARA	2	Damiano

1 - 2 - L.299 x H 1915 x sp6

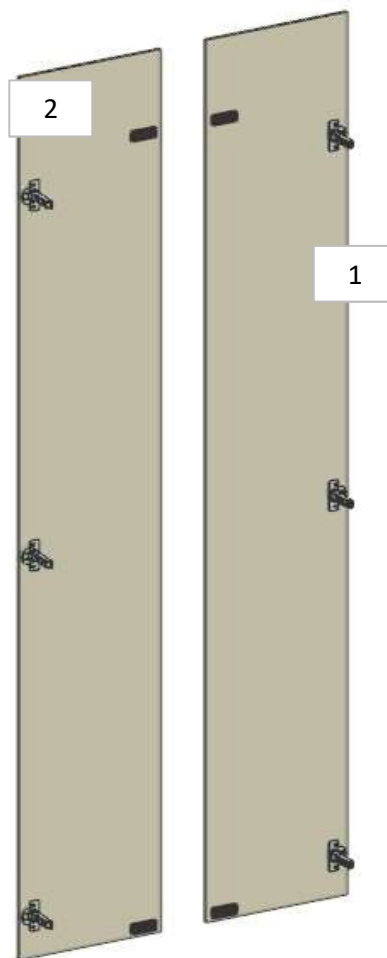

AZ68F

REV. 29-04-2024

LOCALE	CODICE	DESCRIZIONE COMPONENTE	FINITURA	Q.TA	OPERATORE
CABINA ARMATORE	AZ68F-R01_AV01	CIELINO	LASTRA CHIARA	6	Damiano

133
MODIFICATA
SAGOMA

DA SPEDIRE CON IL MAIN
DECK

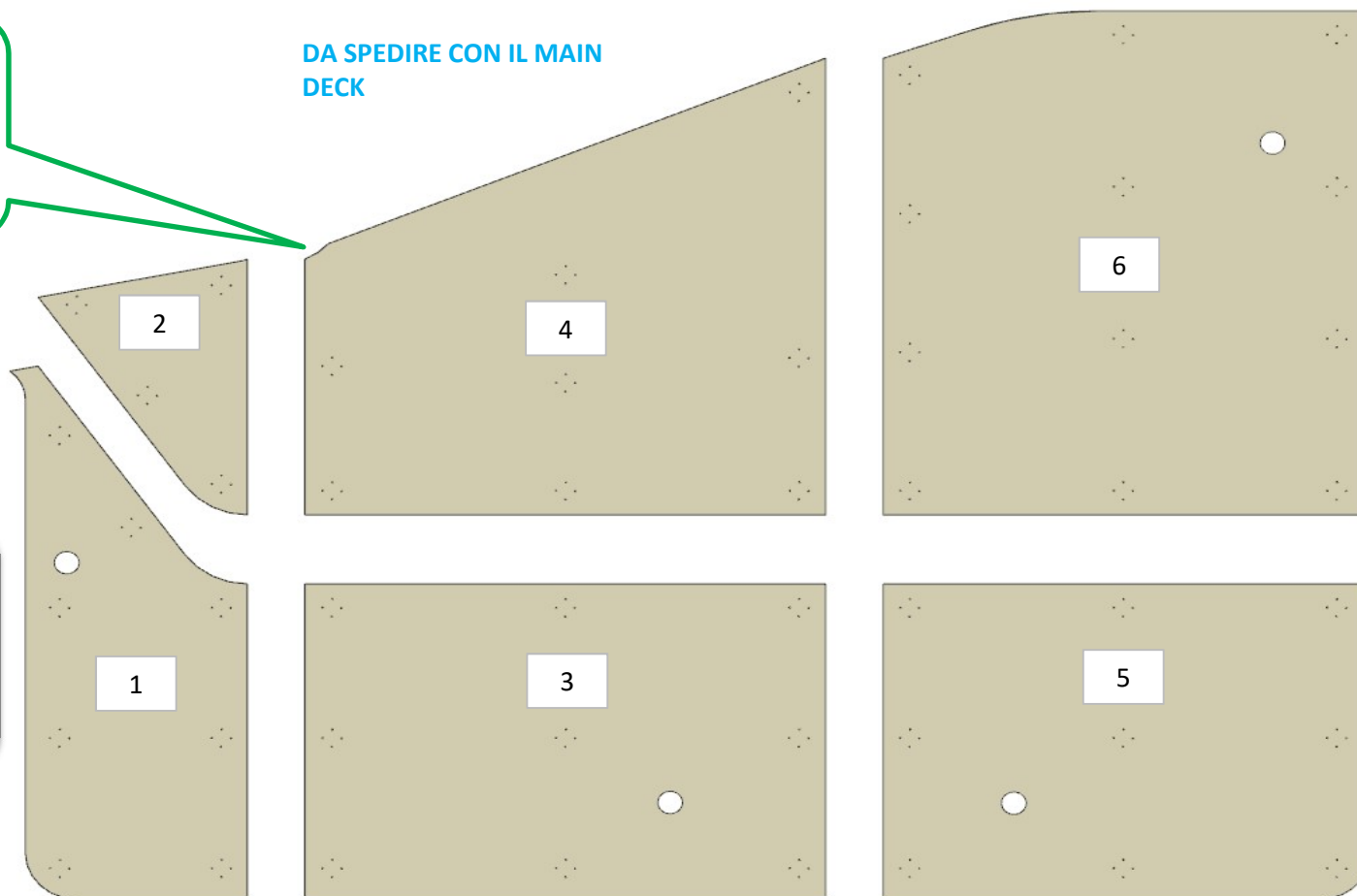

- 1 - L 622 x h 1532 x SP 16
- 2 - L.825 x H.509 x sp 16
- 3 - L.1364 x H 906 x sp 16
- 4 - L.1364 x H.1327 x sp 16
- 5 - L.1253 x H.904 x sp 16
- 6 - L.1259 x H.1466 x sp 16

FERRAMENTA:

N° 77 - FITLOCK MASCHIO

AZ68F

DA MAT. 201 REV. 29-04-2024

LOCALE	CODICE	DESCRIZIONE COMPONENTE	FINITURA	Q.TA	OPERATORE
CABINA ARMATORE	AZ68F-R01_AAA01	VANITY OPT	LASTRA CHIARA	1	Damiano

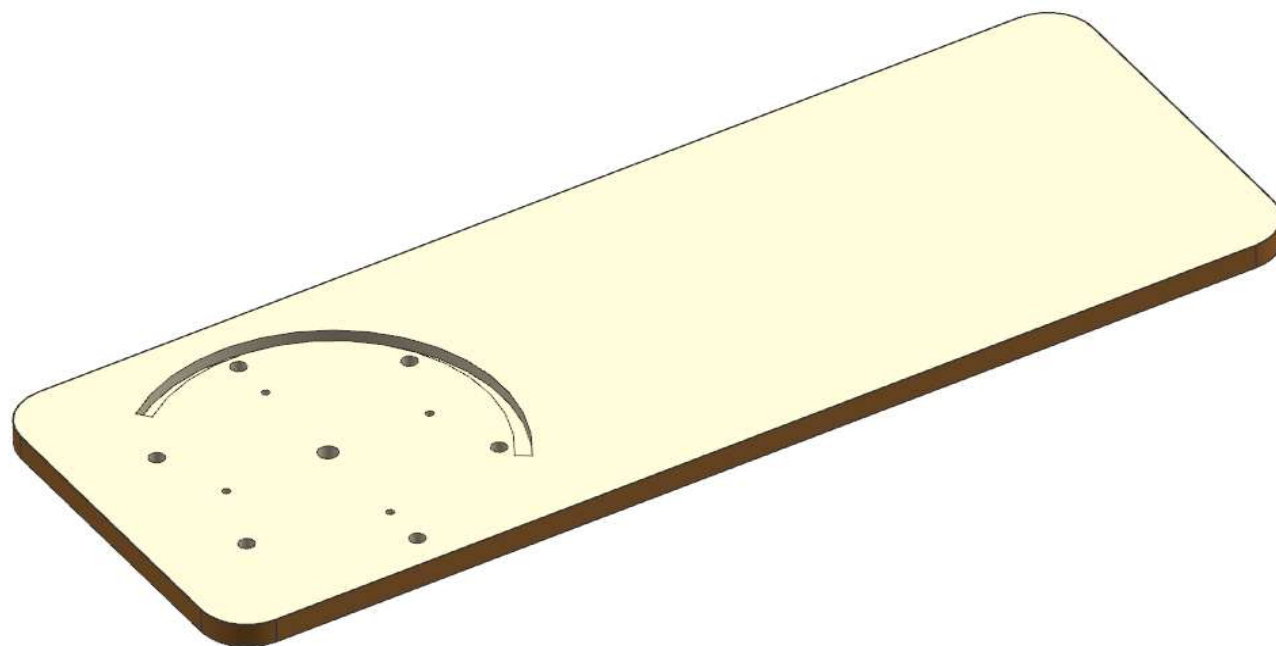

1 - L 1150 x H 416 x sp 30 mm

ELEMENTO DA MONTARE con:
AAA01
L01_AAA01
L02_AAA01
S01_AAA01
e spedire con un unico imballo

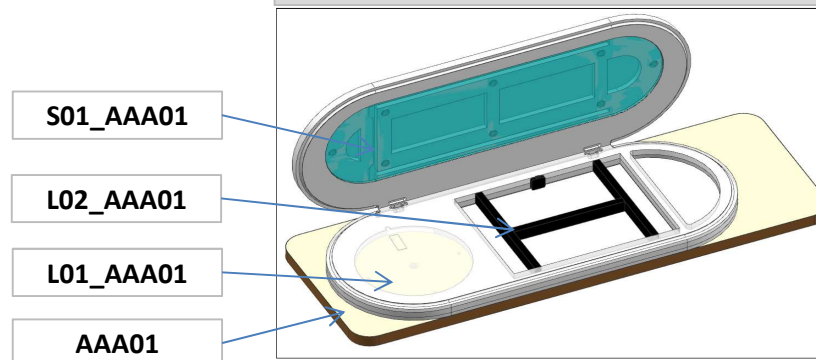

consonni&c

AZ68F

DA MAT. 233 REV. 29-04-2024

LOCALE	CODICE	DESCRIZIONE COMPONENTE	FINITURA	Q.TA	OPERATORE
CABINA ARMATORE	AZ68F-R01_AAL01	ARMADIO DX POPPA OPT	LASTRA CHIARA	2	Damiano

1 - L. 536 x H 1917 x sp 8
2 - L. 99 x H 1966 x sp 16

ELIMINATI RIBASSI

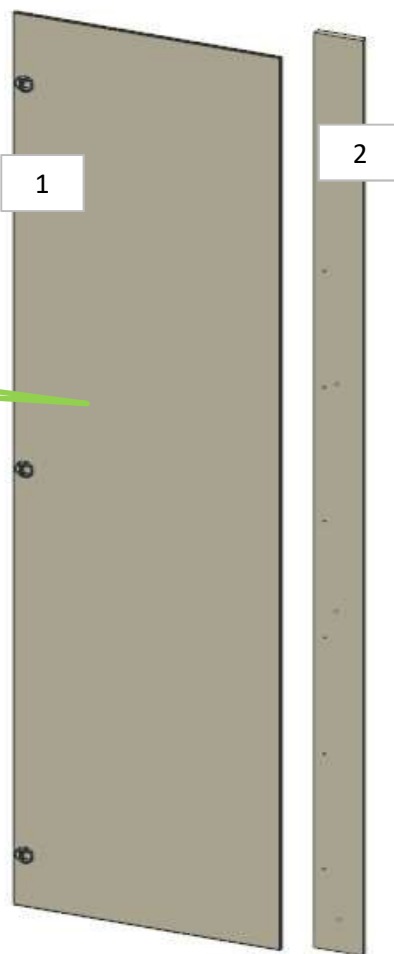

AZ68F

DA MAT. 203 REV. 29-04-2024

LOCALE	CODICE	DESCRIZIONE COMPONENTE	FINITURA	Q.TA	OPERATORE
CABINA ARMATORE	AZ68F-R01_AAM01	STRUTTURA DX ANGOLO POPPA OPT	LASTRA CHIARA	4	Damiano

- 1 - L 460 x H 1701 x sp 16
- 2 - L 316 x H 1080 x sp 16
- 3 - L 280 x H 978 x sp 16
- 4 - dia.32 x H 805mm

ID 1673
NON SPEDIRE
SEPARATAMENTE

METTERE BORDO

ELEMENTO DA
MONTARE con:
L01_AAM01
e spedire con un unico
imballo

FISSARE GREZZO

L01_AAM01

consonni&c



AZ68F

DA MAT. 207 REV. 29-04-2024

LOCALE	CODICE	DESCRIZIONE COMPONENTE	FINITURA	Q.TA	OPERATORE
CABINA ARMATORE	AZ68F-R01_AAN01	STRUTTURA ALTA TEATRINO MURATA DX OPT	LASTRA CHIARA	2	Damiano

1 - L 2307 x H 193 x sp 16
2 - L 2276 x H 266 x sp 16

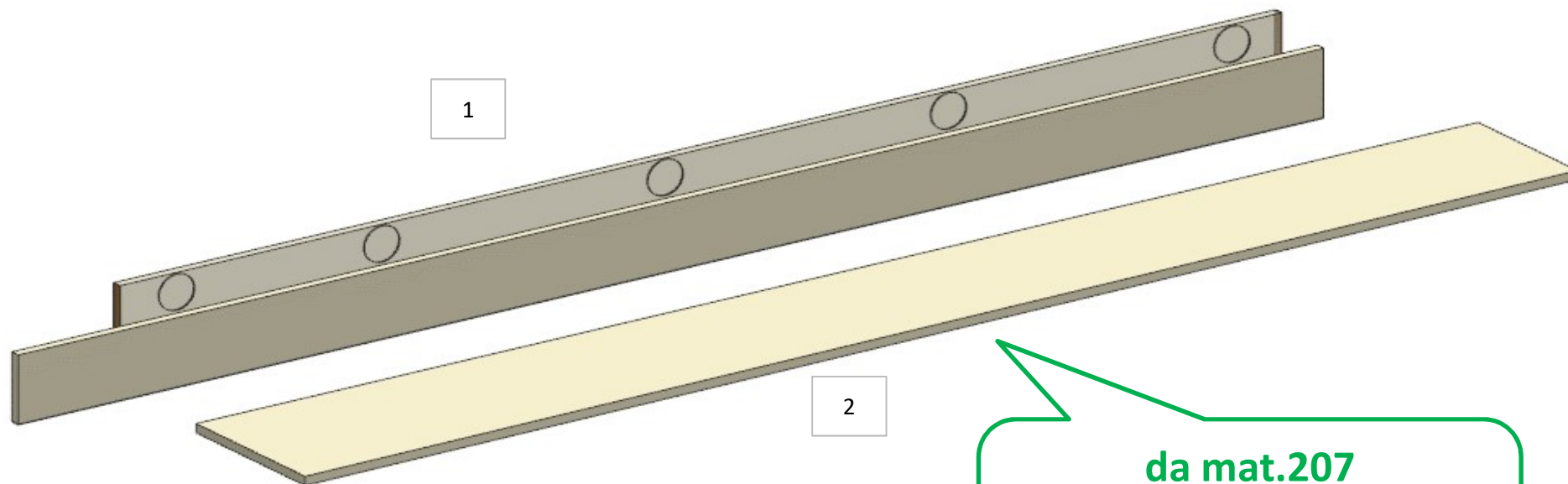

AZ68F

DA MAT. 203 REV. 29-04-2024

LOCALE	CODICE	DESCRIZIONE COMPONENTE	FINITURA	Q.TA	OPERATORE
CABINA ARMATORE	AZ68F-R01_AA001	STRUTTURA BASSA A MURATA DX OPT	LASTRA CHIARA	2	Damiano

1 - L 2276 x H 228 x sp 16
2 - L 2308 x H 82,5 x sp 16

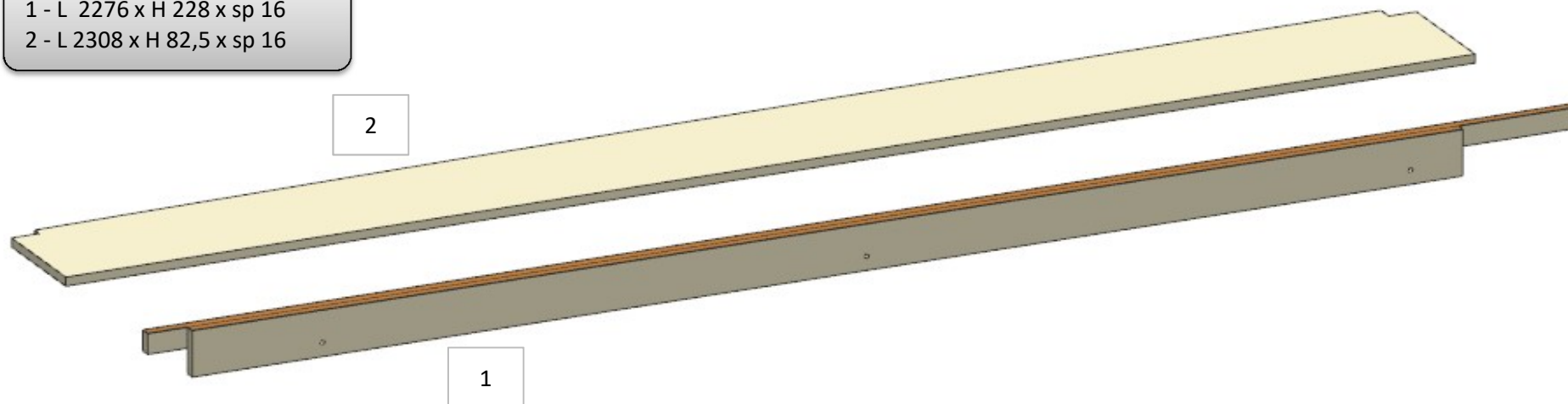

ELEMENTO DA MONTARE con:
L01_AA001
e spedire con un unico imballo

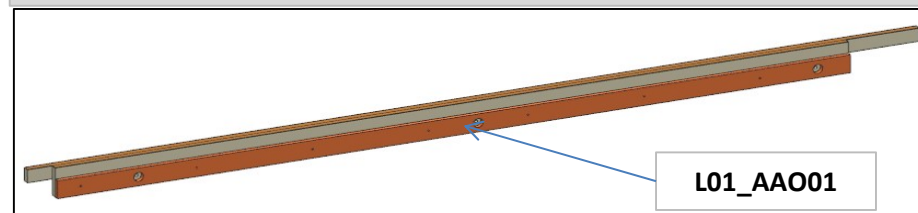

AZ68F

DA MAT. 233 REV. 29-04-2024

LOCALE	CODICE	DESCRIZIONE COMPONENTE	FINITURA	Q.TA	OPERATORE
CABINA ARMATORE	AZ68F-R01_AAR01	COMODINO POPPA OPT	LASTRA CHIARA	3	Damiano

1

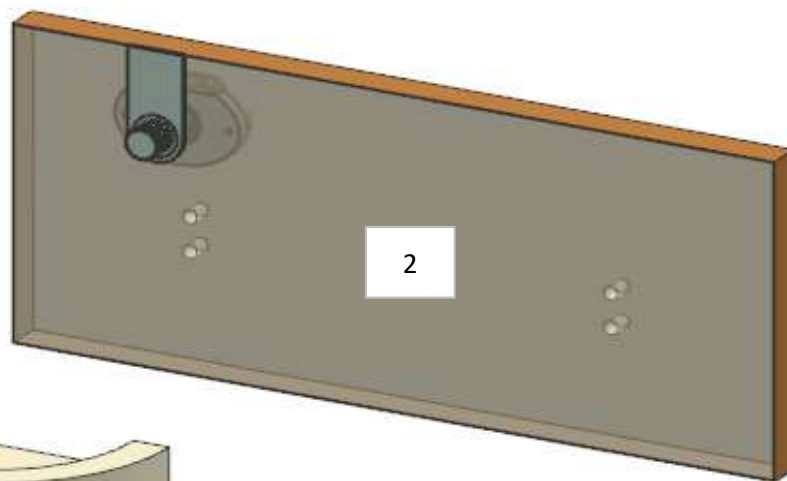
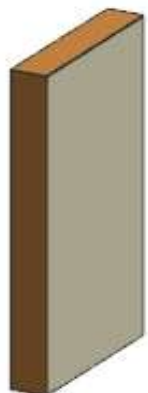

2

1 - L 101 x H 189 x sp 20
 2 - L 426 x H 189 x sp 20
 3 - L 158 x H 189 x 100

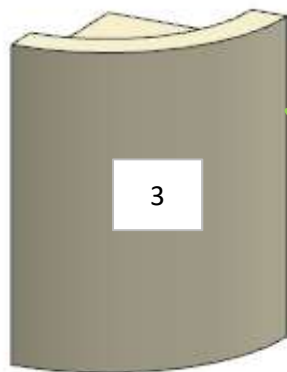

3

COMPOSTO DA PIÙ STRATI DI MDF (16mm + 5pz da 30 mm + 23mm) DA INCOLLARE E RIVESTIRE IN LASTRA SUPPORTATA

ELEMENTO DA MONTARE con:
AAR01
L01_AAR01
L02_AAR01
 e spedire con un unico imballo

L01_AAR01

L02_AAR01

AAR01

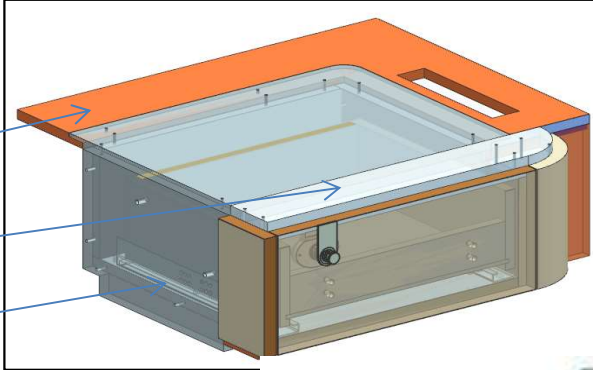

AZ68F

REV. 29-04-2024

LOCALE	CODICE	DESCRIZIONE COMPONENTE	FINITURA	Q.TA	OPERATORE
CABINA ARMATORE	AZ68F-R01_AAV01	CIELINO OPT	LASTRA CHIARA	4	Damiano

- 1 - L 1432 x H 929 x sp 16
- 2 - L 1328 x H 1481 x sp 16
- 3 - L 1278 x H 917 x sp 16
- 4 - L 1278 x H 1465 x sp 16

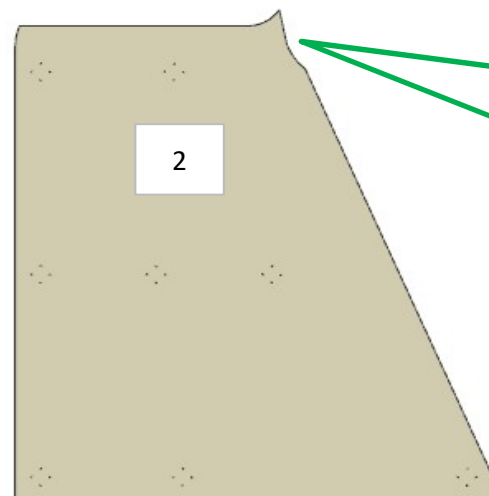
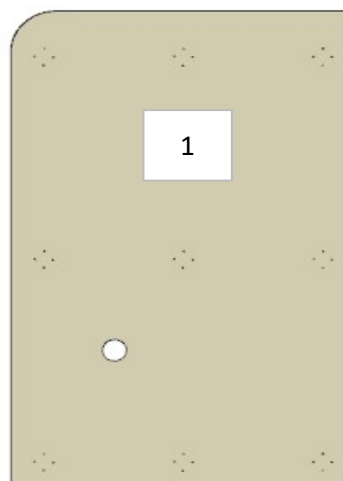

133
MODIFICATA
SAGOMA

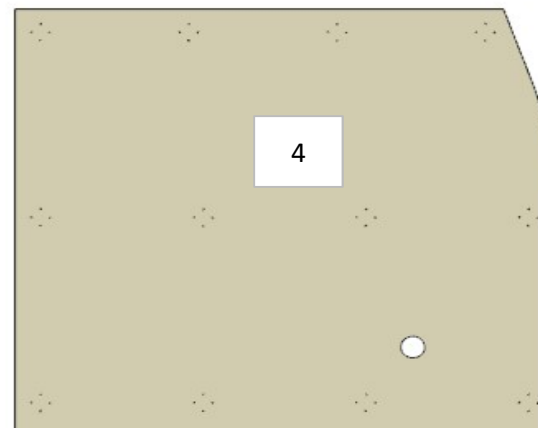
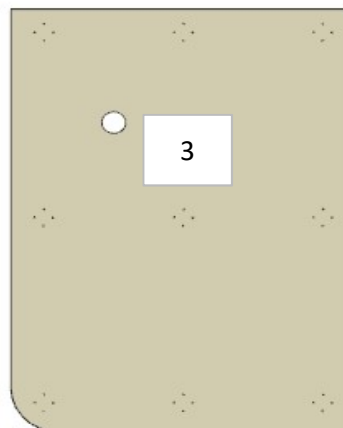

FERRAMENTA:

N° 38 - FITLOCK MASCHIO