

# AZ68F

REV. 29-04-2024

LOCALE	CODICE	DESCRIZIONE COMPONENTE	FINITURA	Q.TA	OPERATORE
CABINA ARMATORE	AZ68F-L01_AA01	STRUTTURE BASSE A MURATA SX	LACCATO BRONZO	1	Damiano

1 - L .2104 x H.50 x sp12

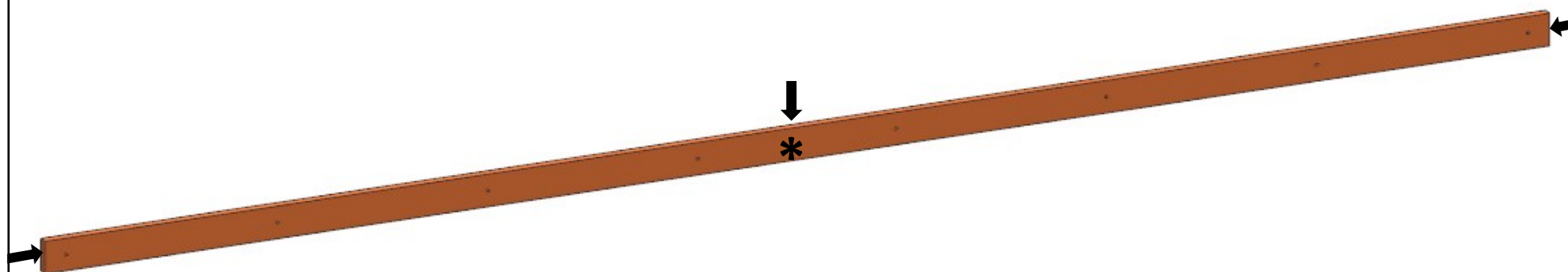

\* faccia dove viene applicata la finitura

↓ filo dove viene applicata la finitura

consonni&c

# AZ68F

DA MAT. 201 REV. 29-04-2024

LOCALE	CODICE	DESCRIZIONE COMPONENTE	FINITURA	Q.TA	OPERATORE
CABINA ARMATORE	AZ68F-L01_AE01	GRADINO SX	LACCATO BRONZO	4	Damiano

1 - 3 - L.298 x H 141 x sp 30  
2 - 4 - L.172 x H 20 x sp 16

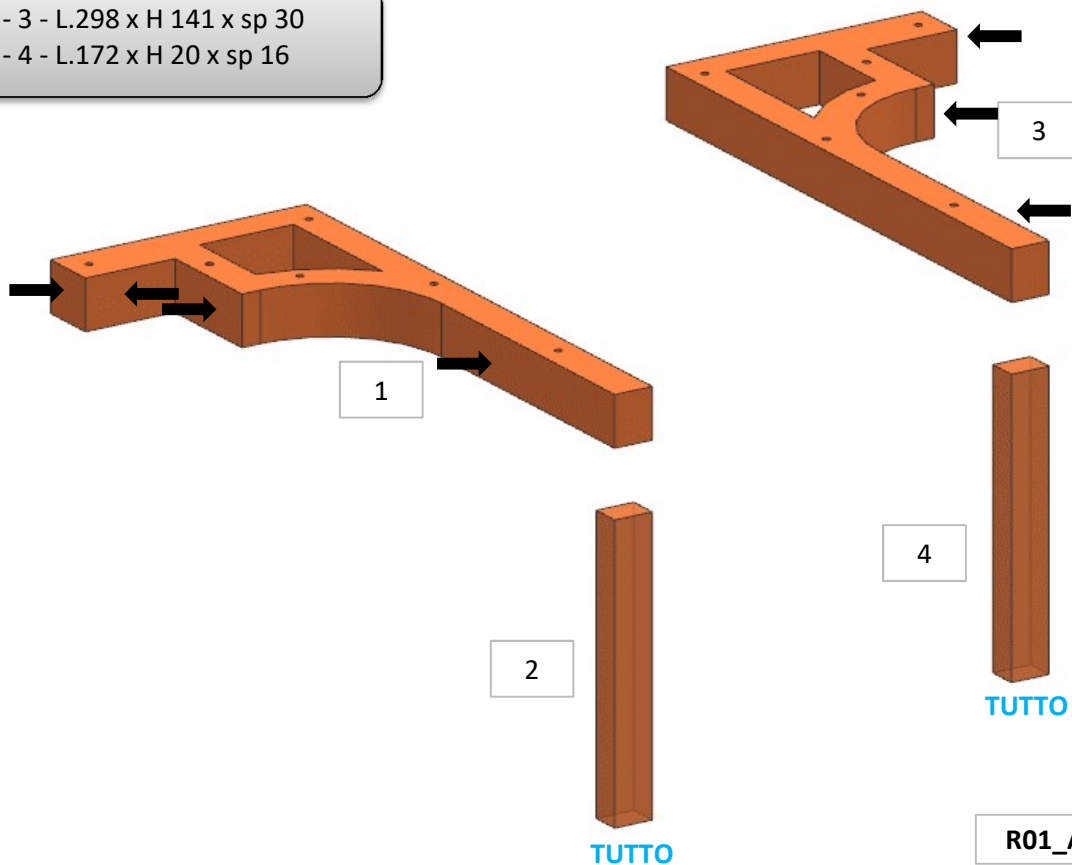

ELEMENTO DA MONTARE con:  
R01\_AE01  
AE01  
X01\_AE01  
e spedire con un unico imballo

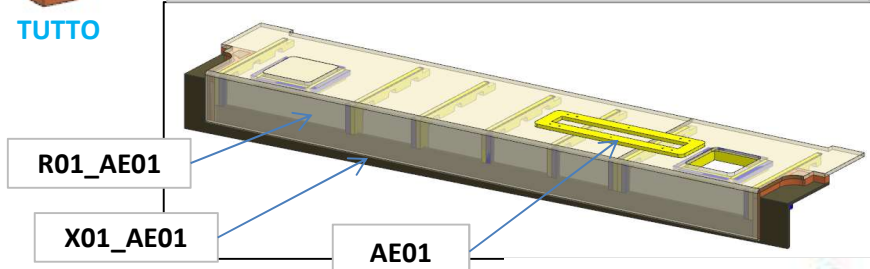

\* faccia dove viene applicata la finitura  
↓ filo dove viene applicata la finitura

# AZ68F

DA MAT. 207 REV. 29-04-2024

LOCALE	CODICE	DESCRIZIONE COMPONENTE	FINITURA	Q.TA	OPERATORE
CABINA ARMATORE	AZ68F-L01_AF01	RIVESTIMENTO POPPA SX	LACCATO BRONZO	2	Damiano

- 1 - L.703 x H 144 x sp 12
- 2 - L.320 x H 50 x sp 12

da mat.207  
ABBASSATO FORO  
FITLOCK

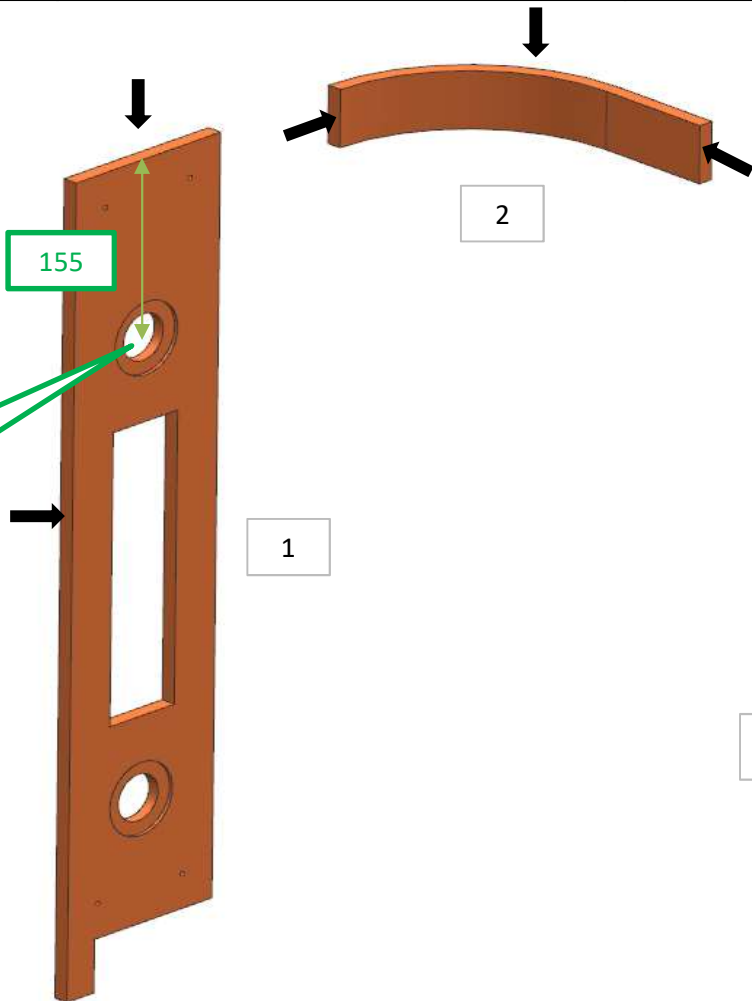

ELEMENTO DA MONTARE con:  
R01\_AF01  
e spedire con un unico imballo

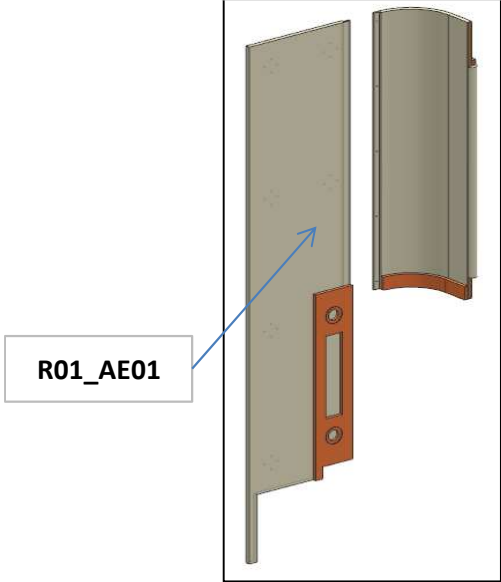

\* faccia dove viene applicata la finitura  
↓ filo dove viene applicata la finitura

# AZ68F

REV. 29-04-2024

LOCALE	CODICE	DESCRIZIONE COMPONENTE	FINITURA	Q.TA	OPERATORE
CABINA ARMATORE	AZ68F-L01_AG01	RIVESTIMENTO PRUA SX	LACCATO BRONZO	2	Damiano

1 - L.703 x H 144 x sp 12  
2 - L.320 x H 50 x sp 12

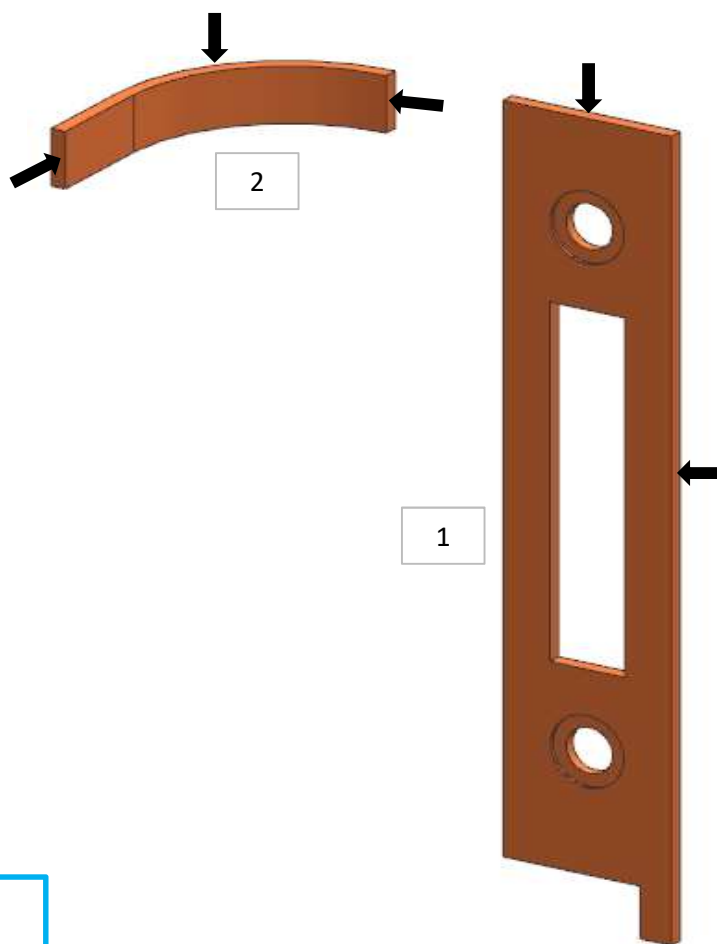

ELEMENTO DA  
MONTARE con:  
**R01\_AG01**  
e spedire con un  
unico imballo

R01\_AG01

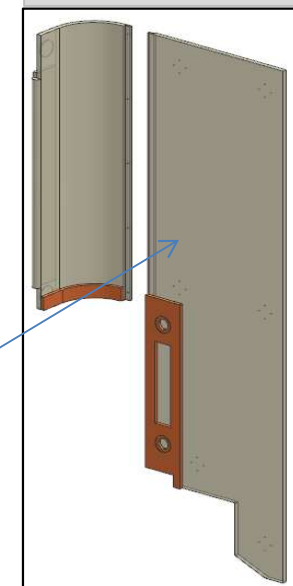

\* faccia dove viene applicata la finitura  
↓ filo dove viene applicata la finitura

consonni&c

# AZ68F

DA MAT. 233 REV. 29-04-2024

LOCALE	CODICE	DESCRIZIONE COMPONENTE	FINITURA	Q.TA	OPERATORE
CABINA ARMATORE	AZ68F-L01_AH01	CASSETTIERA SX	LACCATO BIANCO ARTICO	5	Damiano

**ID-1428**  
VERIFICARE CORRETTO

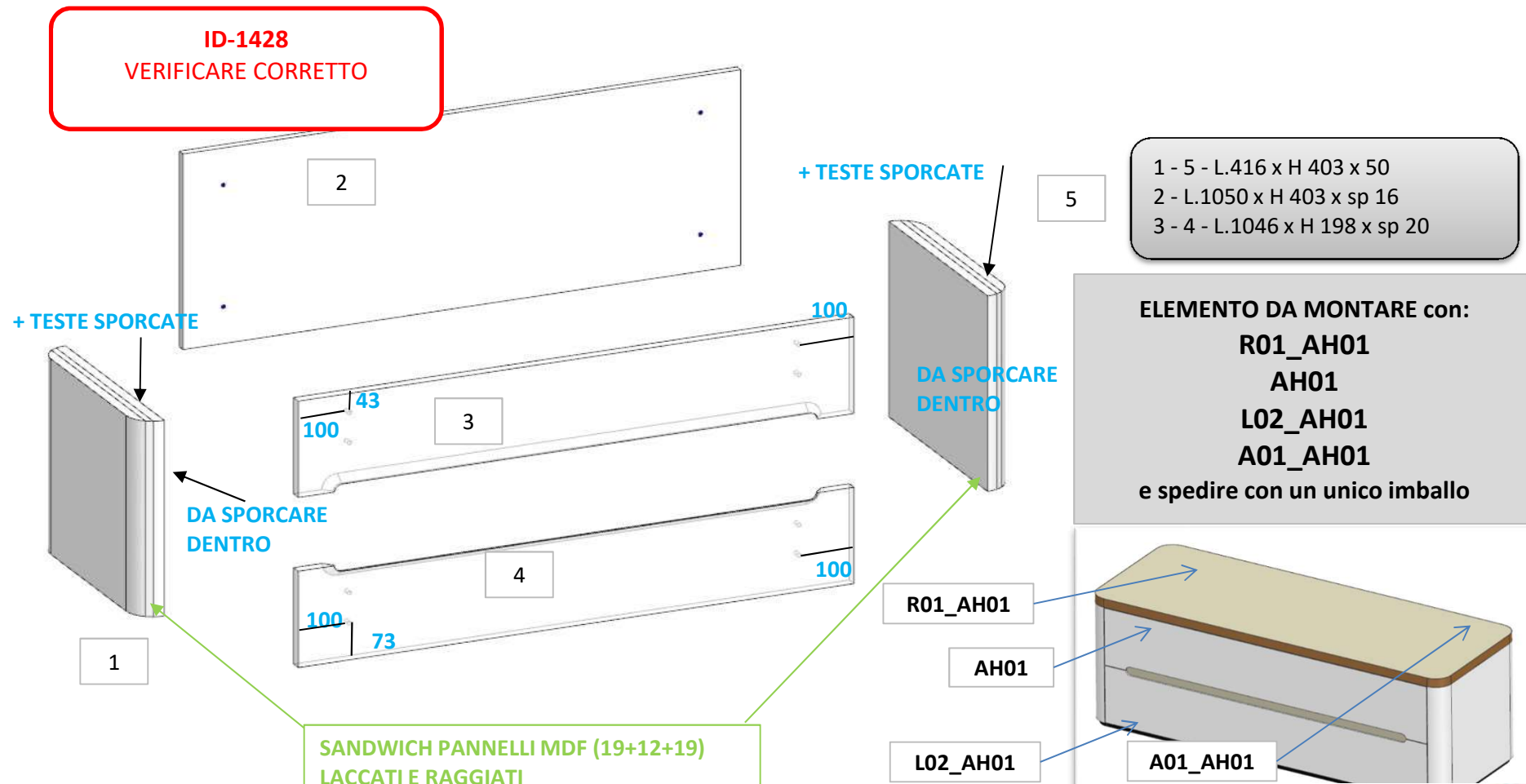

# AZ68F

REV. 29-04-2024

LOCALE	CODICE	DESCRIZIONE COMPONENTE	FINITURA	Q.TA	OPERATORE
CABINA ARMATORE	AZ68F-L02_AH01	CASSETTIERA SX	LACCATO BRONZO	1	Damiano

1 - L 396 x H.1130 x sp 16

FILI

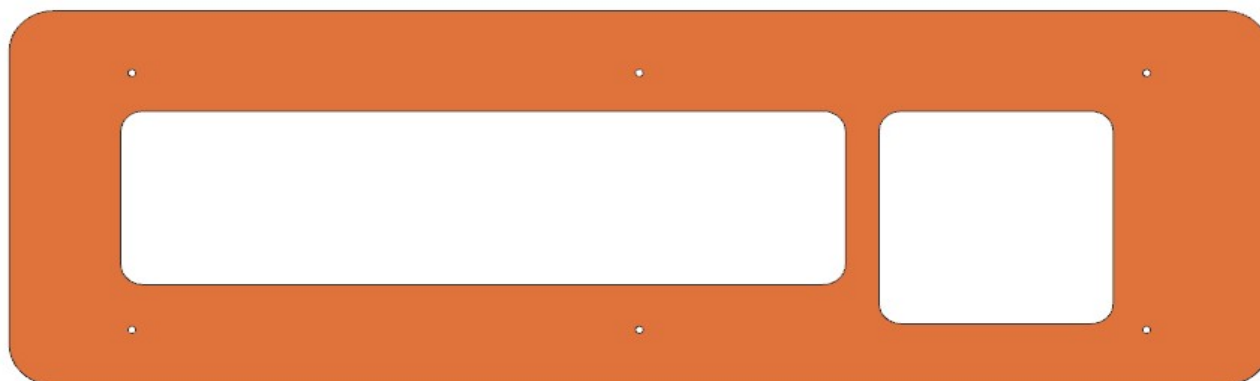

ELEMENTO DA MONTARE con:

R01\_AH01

L01\_AH01

AH01

A01\_AH01

e spedire con un unico imballo

R01\_AH01

L01\_AH01

AH01

A01\_AH01

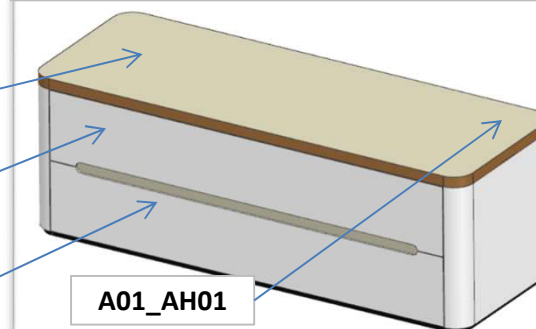

consonni&c

# AZ68F

REV. 29-04-2024

LOCALE	CODICE	DESCRIZIONE COMPONENTE	FINITURA	Q.TA	OPERATORE
CABINA ARMATORE	AZ68F-L01_AM01	STRUTTURA DX ANGOLO POPPA	LACCATO BRONZO	3	Damiano

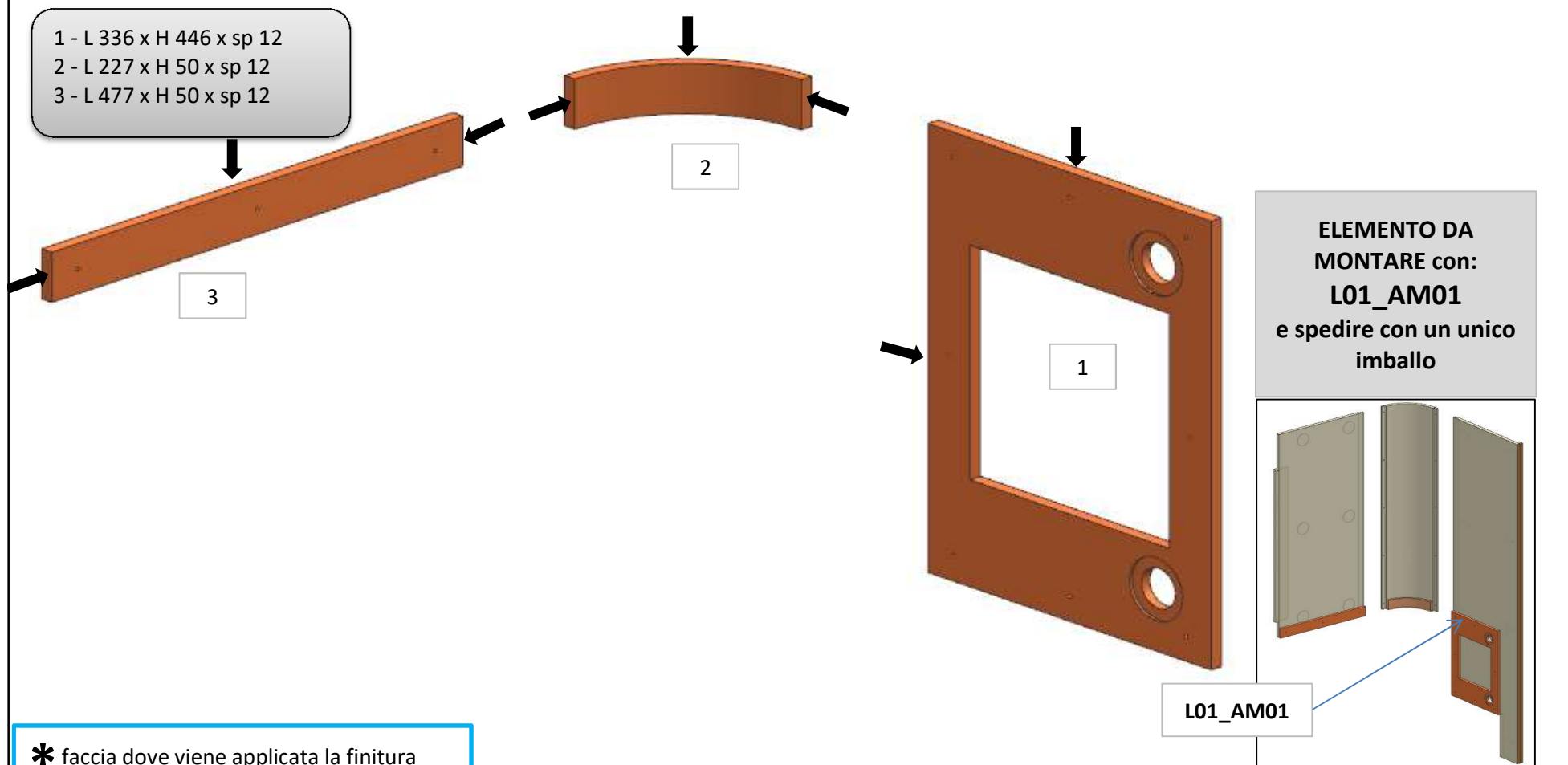

\* faccia dove viene applicata la finitura  
 ↓ filo dove viene applicata la finitura

# AZ68F

REV. 29-04-2024

LOCALE	CODICE	DESCRIZIONE COMPONENTE	FINITURA	Q.TA	OPERATORE
CABINA ARMATORE	AZ68F-L01_AO01	STRUTTURA BASSA A MURATA DX	LACCATO BRONZO	1	Damiano

1 - L.2178 x H.50 x sp 12

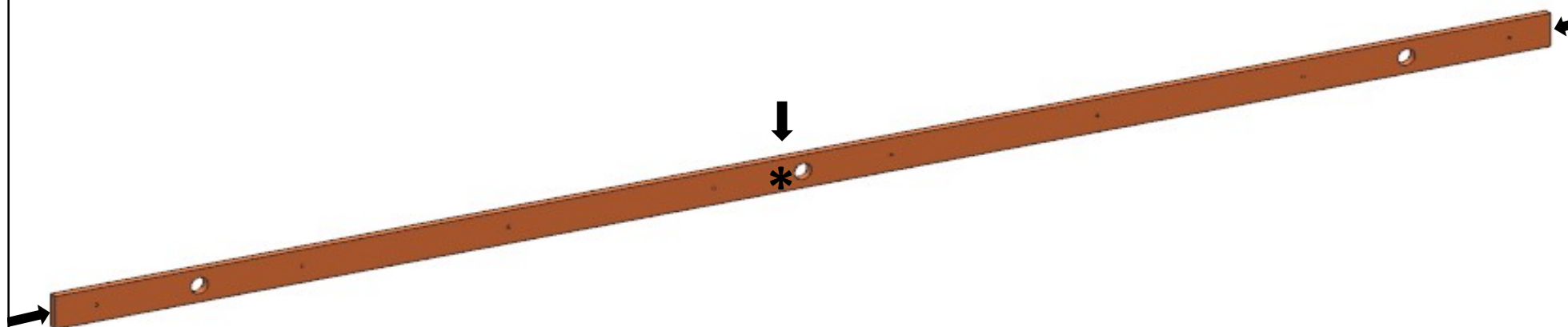

ELEMENTO DA MONTARE con:  
**R01\_AO01**  
e spedire con un unico imballo

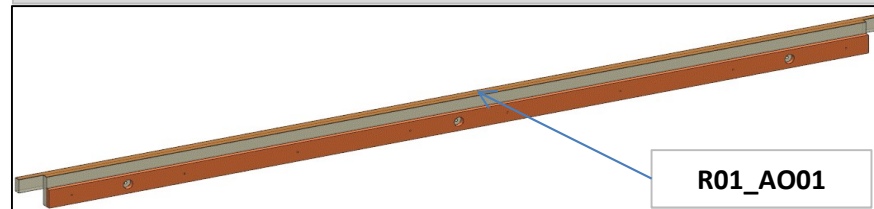

\* faccia dove viene applicata la finitura

↓ filo dove viene applicata la finitura

consonni&c

# AZ68F

REV. 29-04-2024

LOCALE	CODICE	DESCRIZIONE COMPONENTE	FINITURA	Q.TA	OPERATORE
CABINA ARMATORE	AZ68F-L01_AP01	STRUTTURA DX ANGOLO PRUA	LACCATO BRONZO	3	Damiano

- 1 - L.336 x H 446 x sp 12
- 2 - L.227 x H 50 x sp 12
- 3 - L 318 x H 50 x sp 12

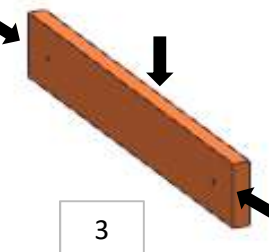
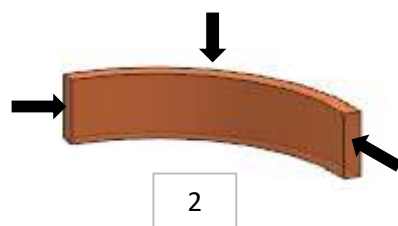
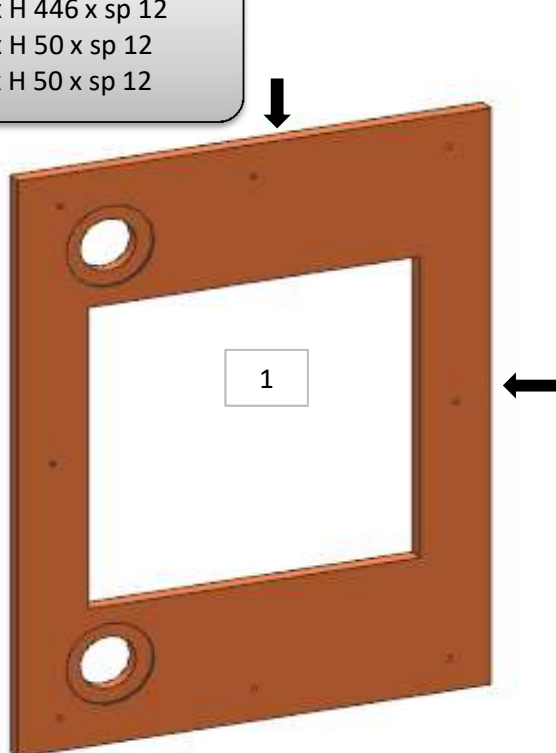

**ELEMENTO DA MONTARE**  
con:  
**R01\_AP01**  
e spedire con un unico  
imballo

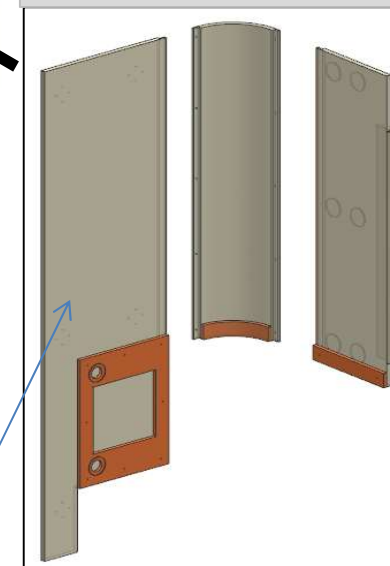

R01\_AP01

\* faccia dove viene applicata la finitura  
↓ filo dove viene applicata la finitura

# AZ68F

DA MAT. 237 REV. 29-04-2024

LOCALE	CODICE	DESCRIZIONE COMPONENTE	FINITURA	Q.TA	OPERATORE
CABINA ARMATORE	AZ68F-L01_AQ01	LETTO	LACCATO BIANCO ARTICO	3	Damiano

1 - 3 - L 1433 x H 32 x 36  
2 - L 1650 x H 32 x 36

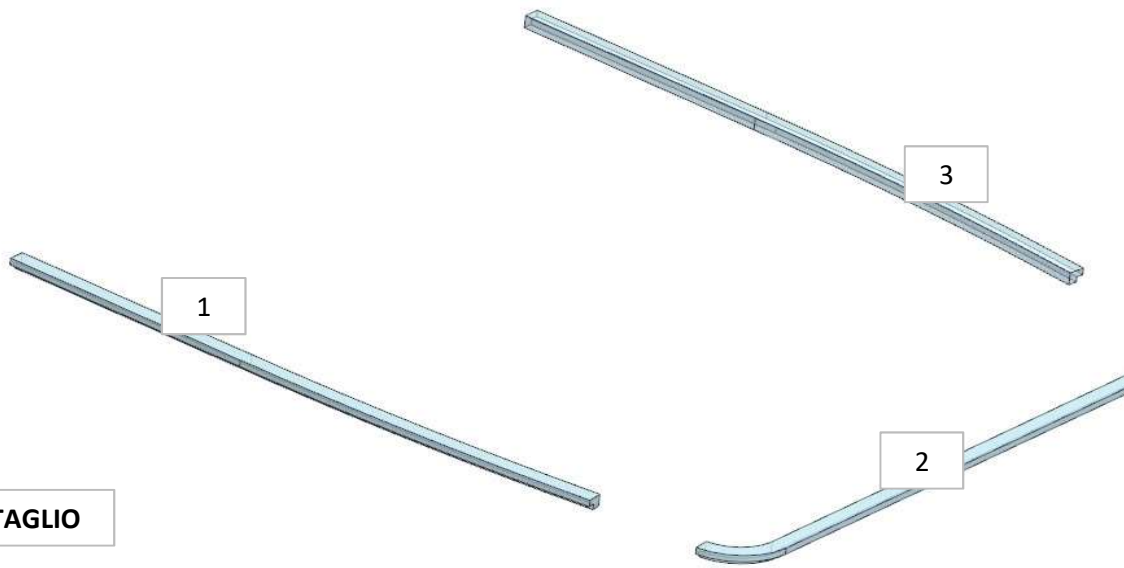

ELEMENTO DA MONTARE con:  
AQ01  
L02\_AQ01  
e spedire con un unico imballo

DETTAGLIO

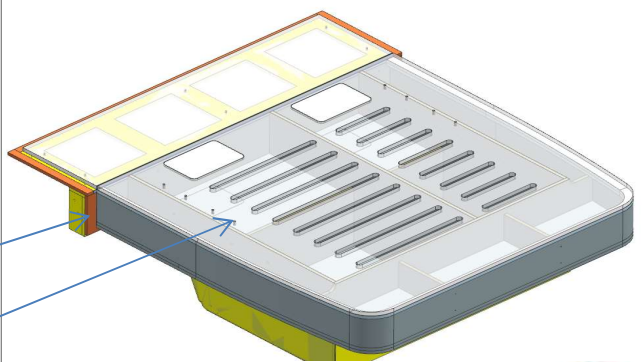
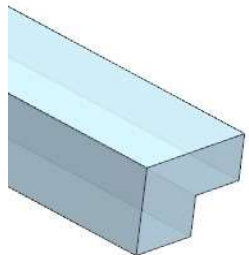

L02\_AQ01  
AQ01

# AZ68F

DA MAT. 203 REV. 29-04-2024

LOCALE	CODICE	DESCRIZIONE COMPONENTE	FINITURA	Q.TA	OPERATORE
CABINA ARMATORE	AZ68F-L02_AQ01	LETTO	LACCATO BRONZO	5	Damiano

- 1 - 4 - L 468 x H 35 x sp 15
- 2 - 3 - L 222 x H 208 x sp 15
- 5 - L 1660 x H 34 x sp 15

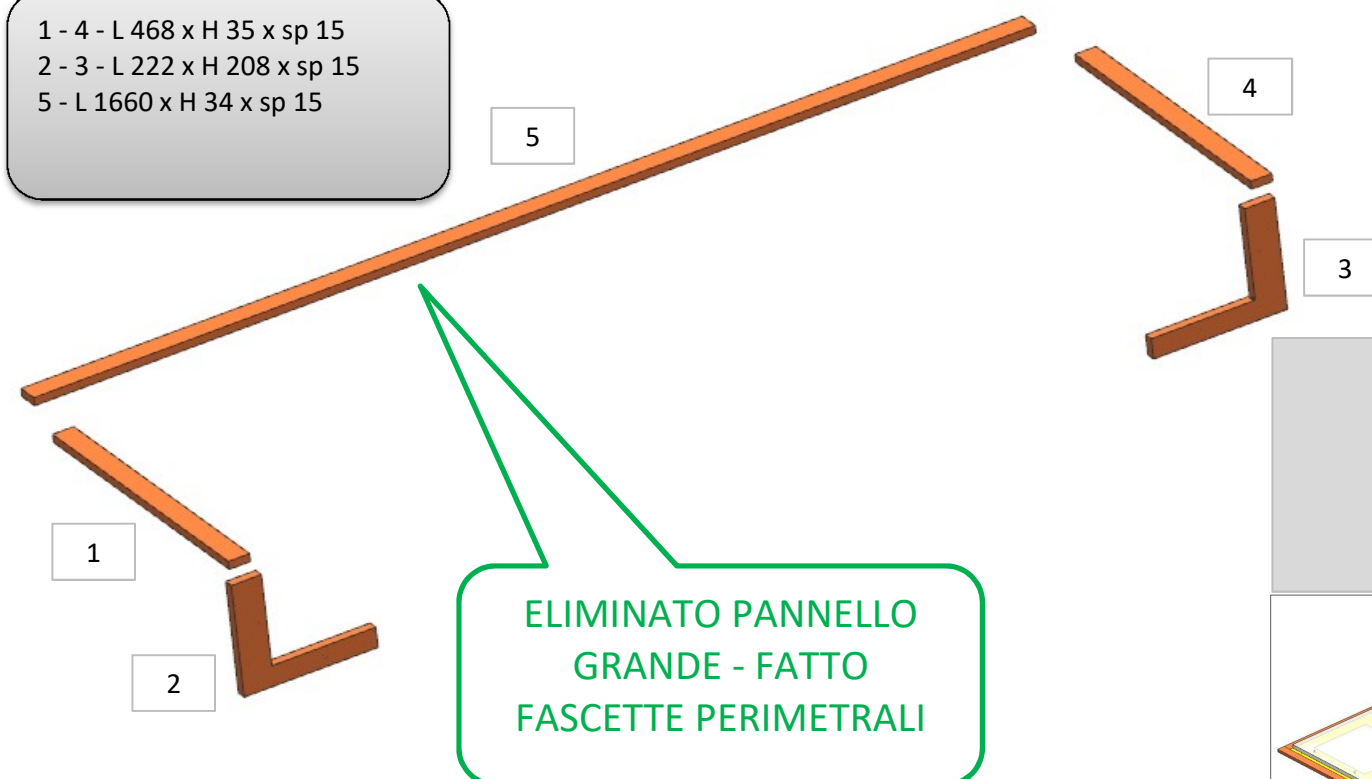

ELEMENTO DA MONTARE con:  
AQ01  
L01\_AQ01  
e spedire con un unico imballo

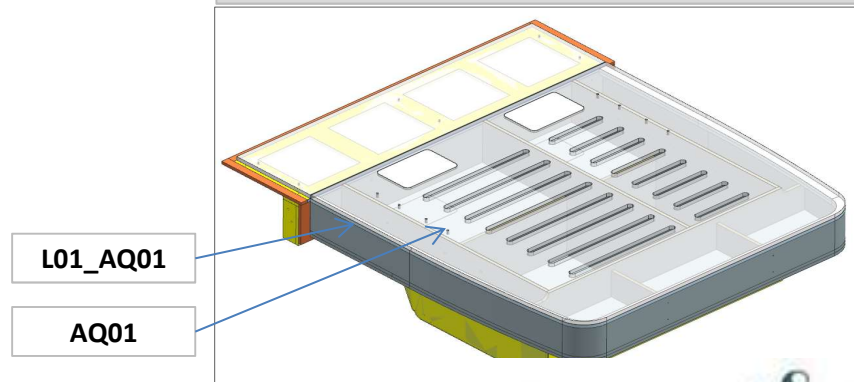

3 e 2 controllare bene la prossima volta

# AZ68F

DA MAT. 211 REV. 29-04-2024

LOCALE	CODICE	DESCRIZIONE COMPONENTE	FINITURA	Q.TA	OPERATORE
CABINA ARMATORE	AZ68F-L03_AQ01	LETTO	LACCATO MOGANO 100 GLOSS	5	Damiano

1 - 5 - L.434 x H 30 x sp 30  
2 - 4 - L 1431 x H 30 x sp 30  
3 - L.1693 x H 30 x sp 30

**RICHIESTA AZIMUT  
01/12/2021  
CONSEGNARE ASSIEME  
AL LETTO MA NON**

DETTAGLIO

# AZ68F

DA MAT. 203 REV. 29-04-2024

LOCALE	CODICE	DESCRIZIONE COMPONENTE	FINITURA	Q.TA	OPERATORE
CABINA ARMATORE	AZ68F-L01_AR01	COMODINO POPPA	LACCATO BIANCO ARTICO	1	Damiano



+FACCIA SOTTO

ELEMENTO DA MONTARE con:  
R01\_AR01  
AR01  
L02\_AR01  
e spedire con un unico imballo

1 - L 1023 x H.81 x sp 32

\* faccia dove viene applicata la finitura  
↓ filo dove viene applicata la finitura

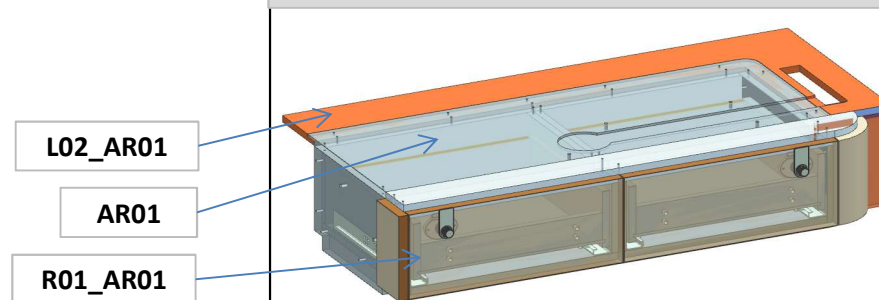

consonni&c

# AZ68F

DA MAT. 203 REV. 29-04-2024

LOCALE	CODICE	DESCRIZIONE COMPONENTE	FINITURA	Q.TA	OPERATORE
CABINA ARMATORE	AZ68F-L02_AR01	COMODINO POPPA	LACCATO BRONZO	3	Damiano

\* faccia dove viene applicata la finitura  
 ↓ filo dove viene applicata la finitura

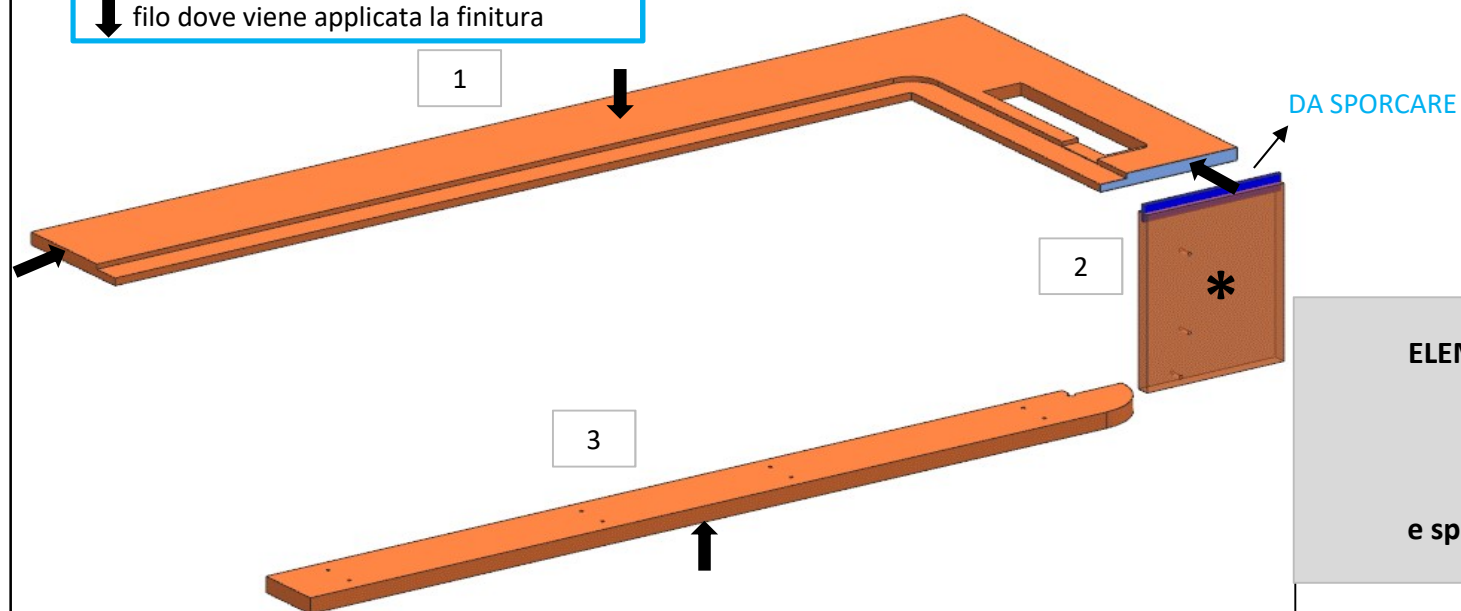

ELEMENTO DA MONTARE con:  
 R01\_AR01  
 L01\_AR01  
 AR01  
 e spedire con un unico imballo

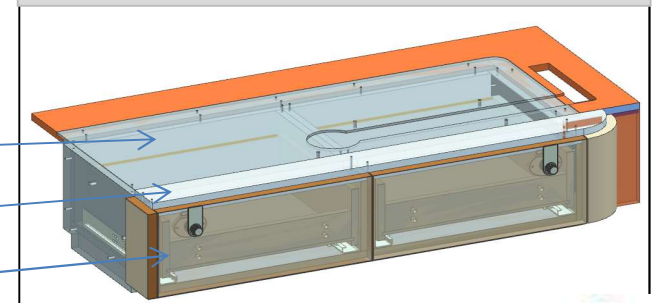

- 1 - L 1105 x H.468 x sp 15
- 2 - L 162 x H.208 x sp 15
- 3 - L 1003 x H.76 x sp 19

- AR01
- L01\_AR01
- R01\_AR01

# AZ68F

DA MAT. 203 REV. 29-04-2024

LOCALE	CODICE	DESCRIZIONE COMPONENTE	FINITURA	Q.TA	OPERATORE
CABINA ARMATORE	AZ68F-L03_AR01	COMODINO POPPA	LACCATO MOGANO 100 GLOSS	1	Damiano

1 - L 1064 x H 535 x sp 32

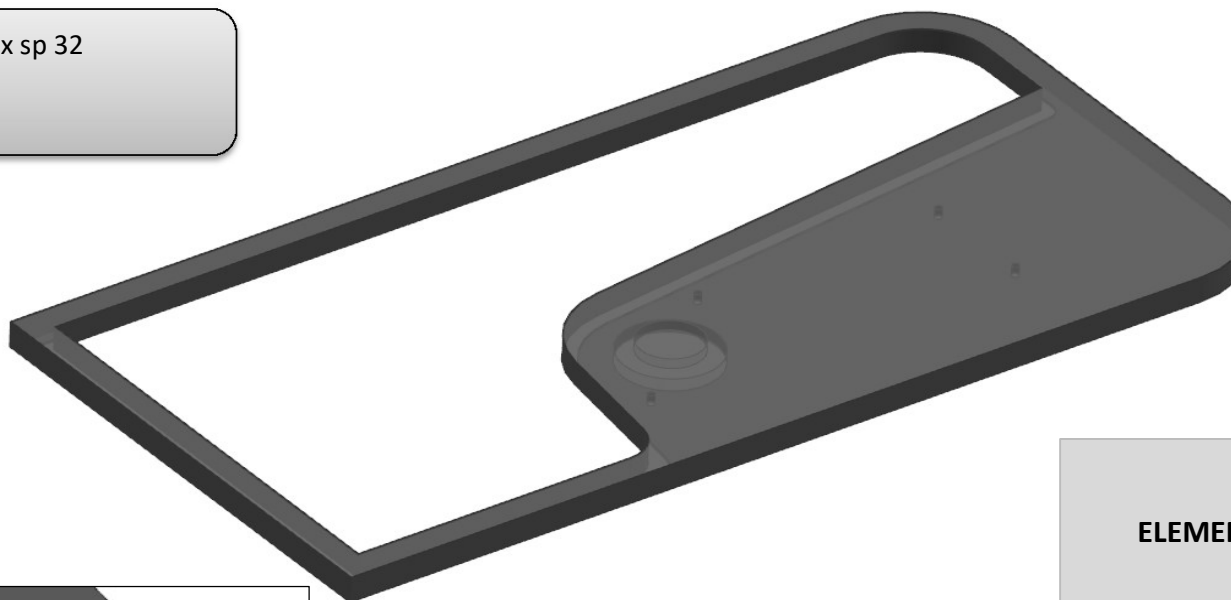

ELEMENTO DA MONTARE con:  
**X01\_AR01**  
e spedire con un unico imballo

DETTAGLIO SEZIONE

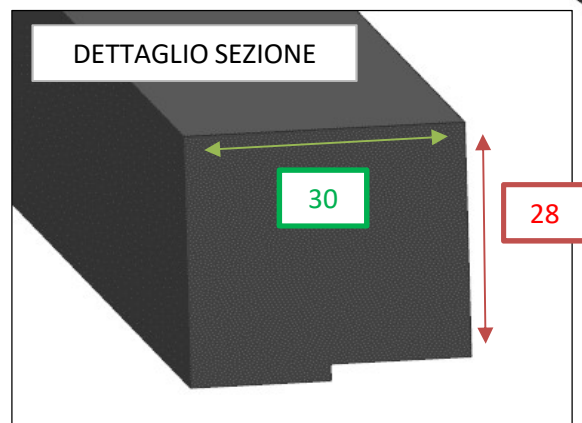

X01\_AR01

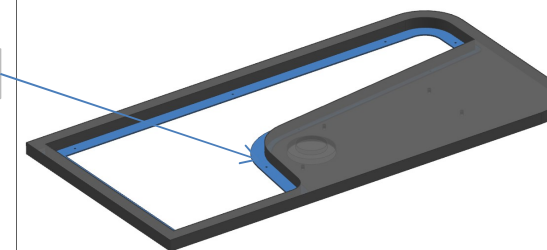

consonni&c

# AZ68F

DA MAT. 203 REV. 29-04-2024

LOCALE	CODICE	DESCRIZIONE COMPONENTE	FINITURA	Q.TA	OPERATORE
CABINA ARMATORE	AZ68F-L01_AS01	COMODINO PRUA	LACCATO BIANCO ARTICO	1	Damiano



+FACCIA SOTTO

ELEMENTO DA MONTARE con:  
R01\_AS01  
AS01  
L02\_AS01  
e spedire con un unico imballo

1 - L.380 x H 81 x sp 32

\* faccia dove viene applicata la finitura

↓ filo dove viene applicata la finitura

L02\_AS01

AS01

R01\_AS01

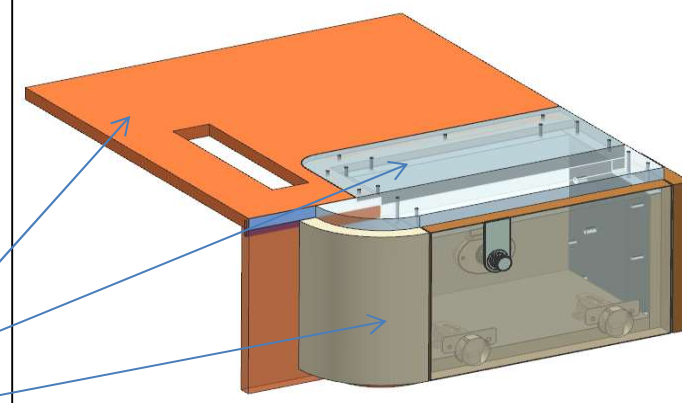

consonni&c

# AZ68F

DA MAT. 203 REV. 29-04-2024

LOCALE	CODICE	DESCRIZIONE COMPONENTE	FINITURA	Q.TA	OPERATORE
CABINA ARMATORE	AZ68F-L02_AS01	COMODINO PRUA	LACCATO BRONZO	3	Damiano

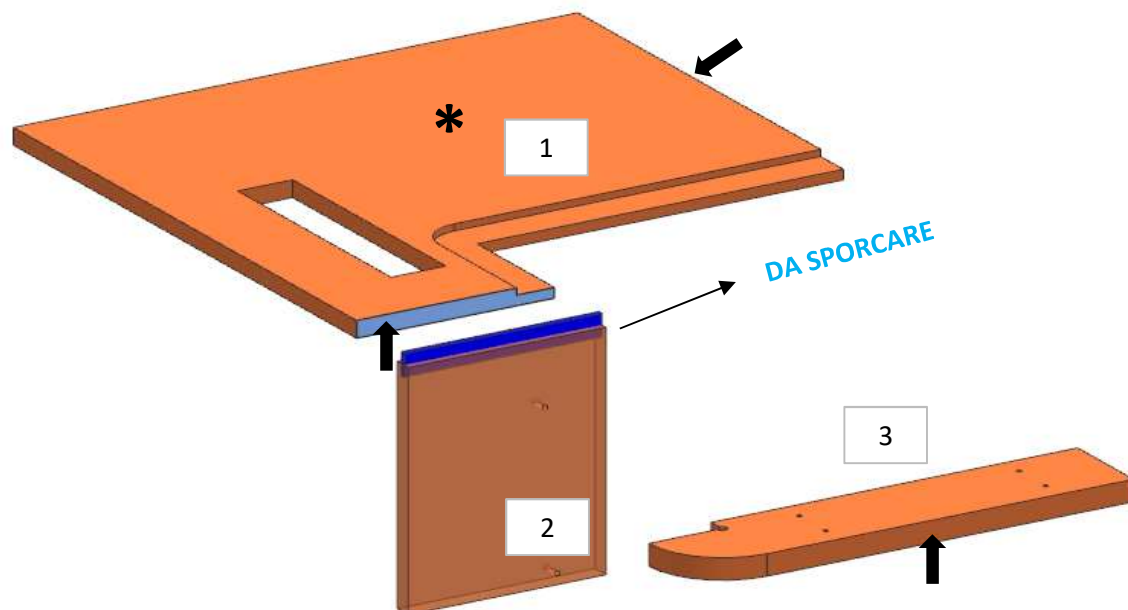

ELEMENTO DA MONTARE con:  
**R01\_AS01**  
**AS01**  
**L01\_AS01**  
 e spedire con un unico imballo

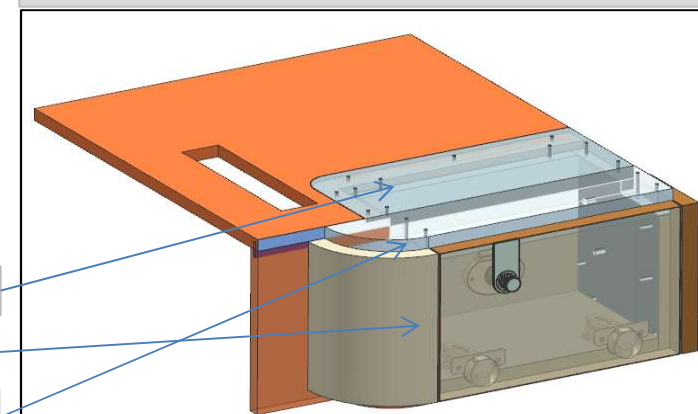

- 1 - L.462 x H.468 x sp 15
- 2 - L.162 x H.208 x sp 15
- 3 - L.360 x H.76 x sp 19

\* faccia dove viene applicata la finitura  
 ↓ filo dove viene applicata la finitura

- AS01
- R01\_AS01
- L01\_AS01

# AZ68F

DA MAT. 203 REV. 29-04-2024

LOCALE	CODICE	DESCRIZIONE COMPONENTE	FINITURA	Q.TA	OPERATORE
CABINA ARMATORE	AZ68F-L03_AS01	COMODINO PRUA	LACCATO MOGANO 100 GLOSS	1	Damiano

1 - L 535 x H 420 x sp 32

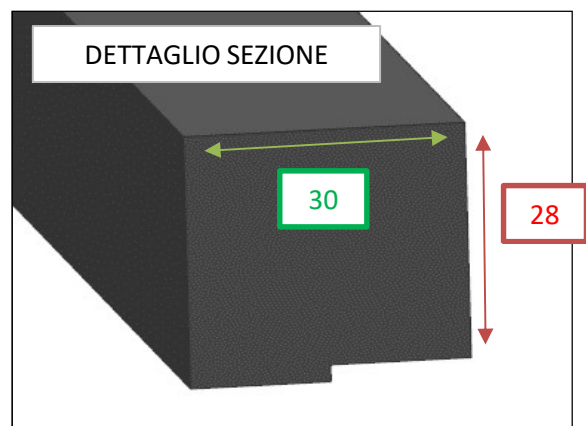
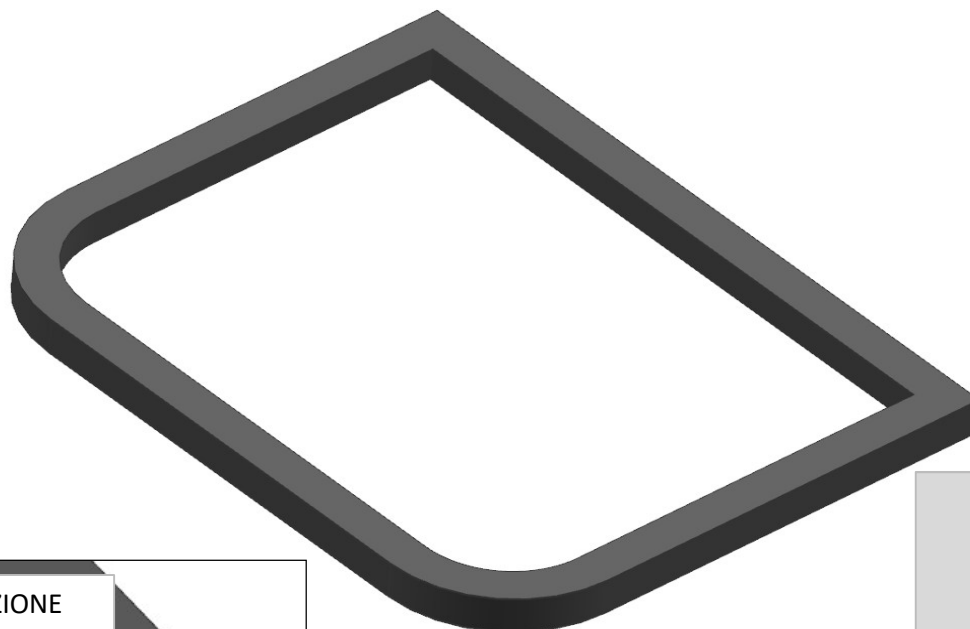

ELEMENTO DA MONTARE con:  
**X01\_AS01**  
e spedire con un unico imballo

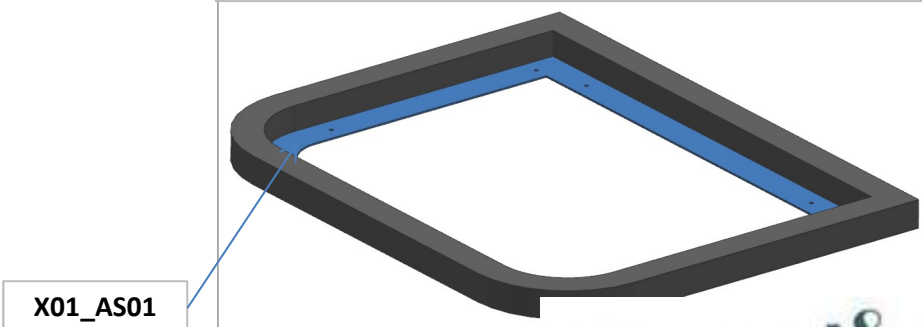

X01\_AS01

# AZ68F

REV. 29-04-2024

LOCALE	CODICE	DESCRIZIONE COMPONENTE	FINITURA	Q.TA	OPERATORE
CABINA ARMATORE	AZ68F-L01_AV01	CIELINO	LACCATO BIANCO ARTICO	2	Damiano

1 - L 1286 x H 1999 x sp 16  
2 - L 1265 x H 1467 x sp 16

**ID-1344**  
RASARE E LACCARE  
TUTTI I FILI

**133**  
MODIFICATA  
SAGOMA

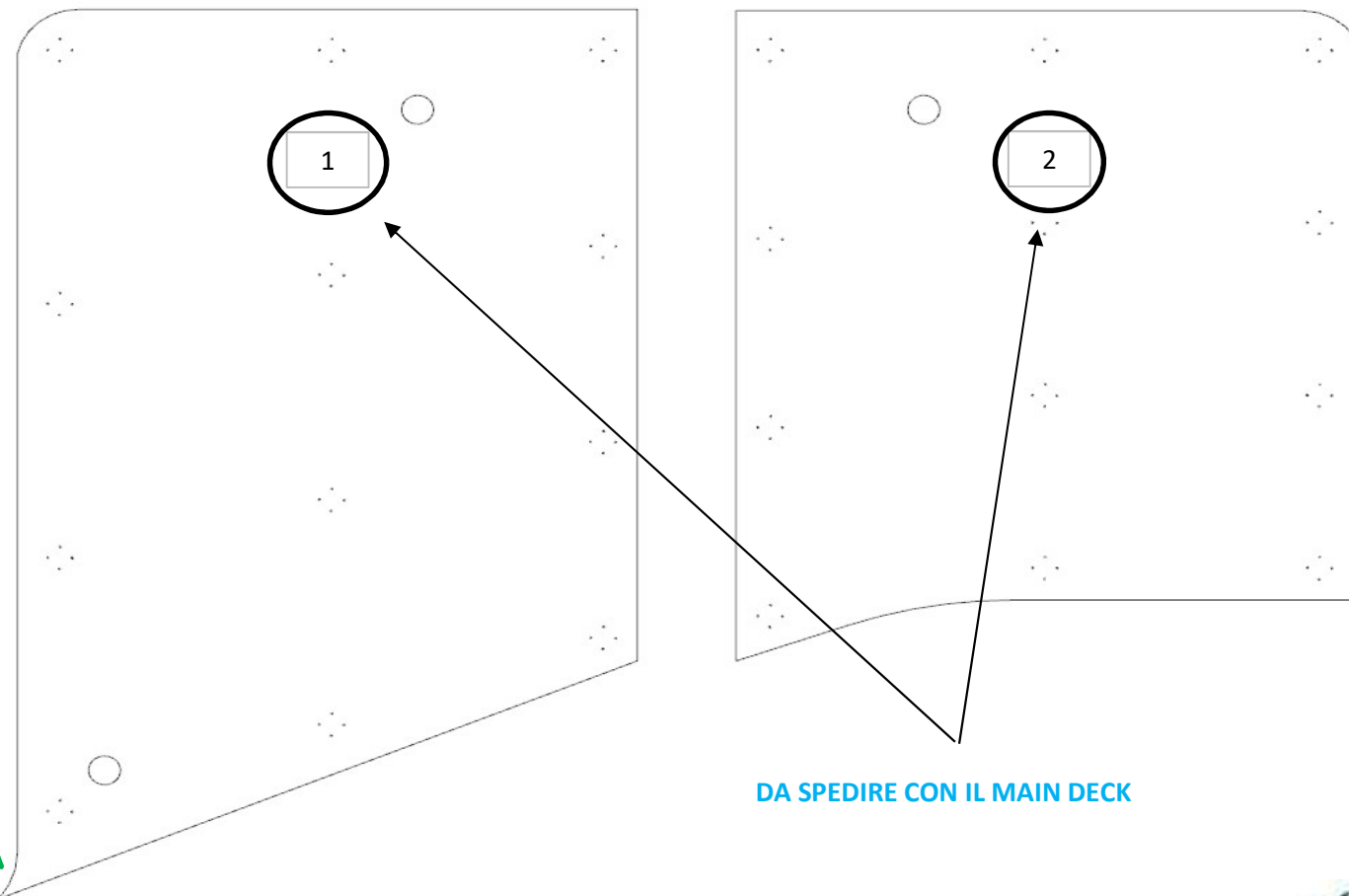

DA SPEDIRE CON IL MAIN DECK

# AZ68F

DA MAT.221 REV. 29-04-2024

LOCALE	CODICE	DESCRIZIONE COMPONENTE	FINITURA	Q.TA	OPERATORE
CABINA ARMATORE	AZ68F-L01_AAA01	VANITY OPT	LACCATO BIANCO ARTICO	2	Damiano

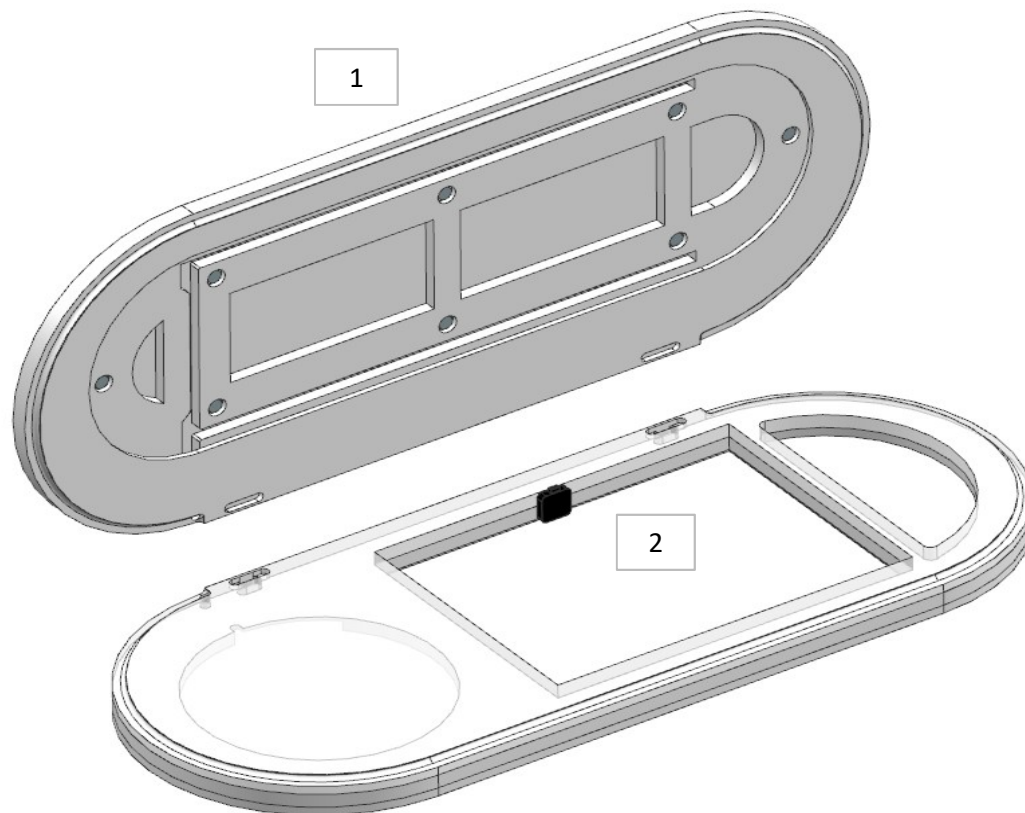

- 1 - L 954 x H 384 x sp 42 mm
- 2 - L 954 x H 384 x sp 25 mm

ELEMENTO DA MONTARE con:  
**AAA01**  
**R01\_AAA01**  
**L02\_AAA01**  
**S01\_AAA01**  
e spedire con un unico imballo

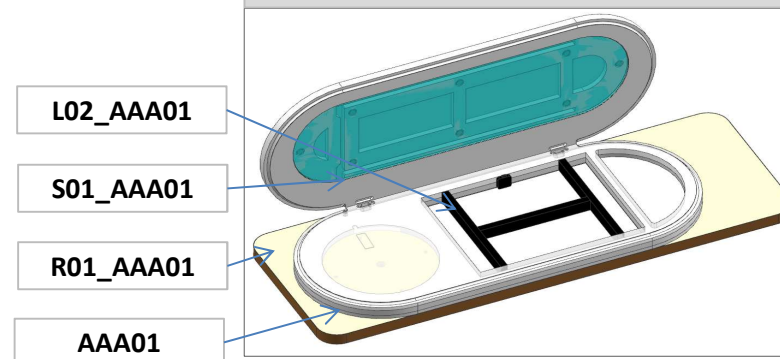

# AZ68F

DA MAT. 201 REV. 29-04-2024

LOCALE	CODICE	DESCRIZIONE COMPONENTE	FINITURA	Q.TA	OPERATORE
CABINA ARMATORE	AZ68F-L02_AAA01	VANITY OPT	LACCATO BIANCO ARTICO	3	Damiano

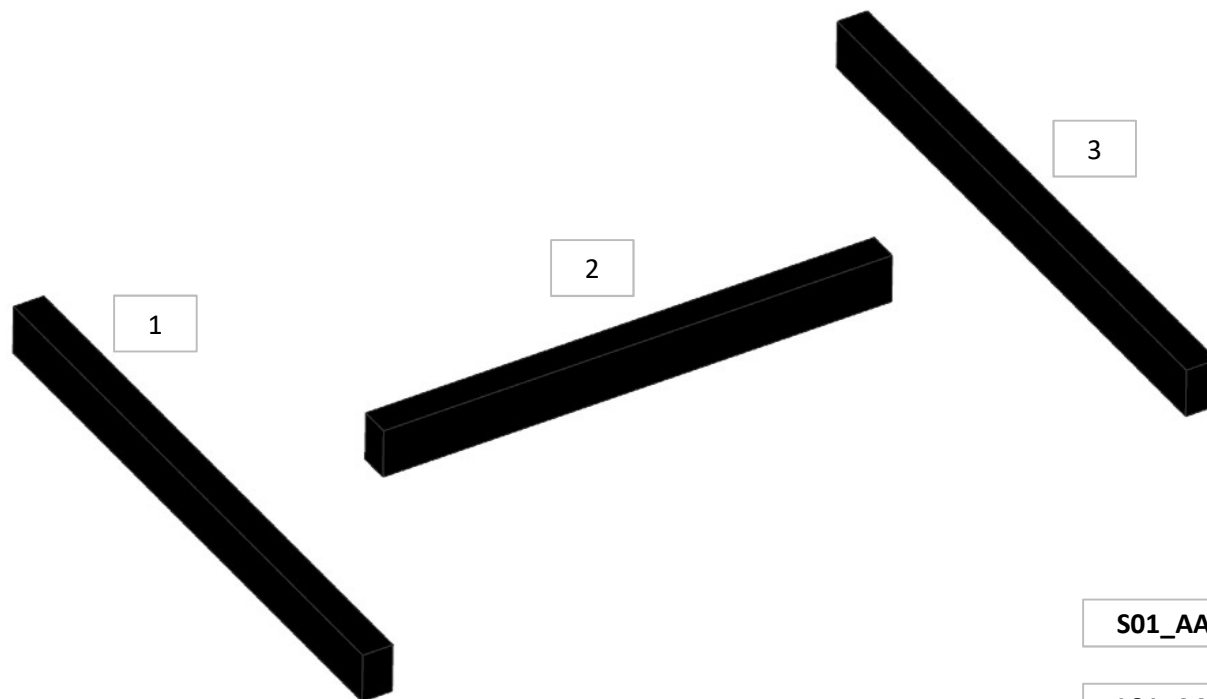

1/3 - L 308 x H 31 x sp 16 mm  
2 - L 267 x H 31 x sp 16 mm

ELEMENTO DA MONTARE con:

AAA01

R01\_AAA01

L01\_AAA01

S01\_AAA01

e spedire con un unico imballo

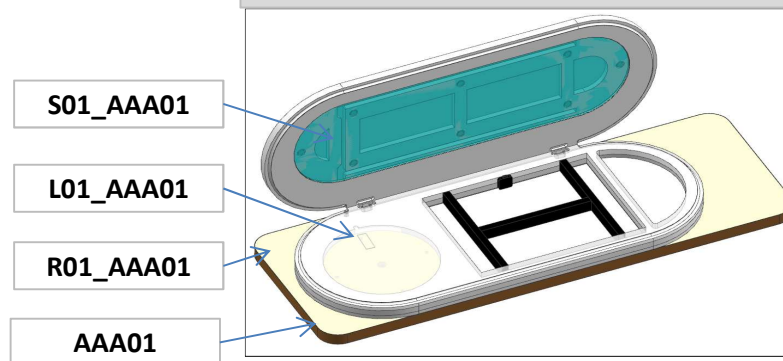

# AZ68F

DA MAT. 203 REV. 29-04-2024

LOCALE	CODICE	DESCRIZIONE COMPONENTE	FINITURA	Q.TA	OPERATORE
CABINA ARMATORE	AZ68F-L01_AAM01	STRUTTURA DX ANGOLO POPPA OPT	LACCATO BRONZO	2	Damiano

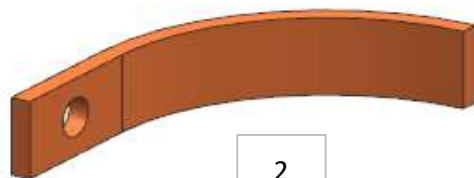

2

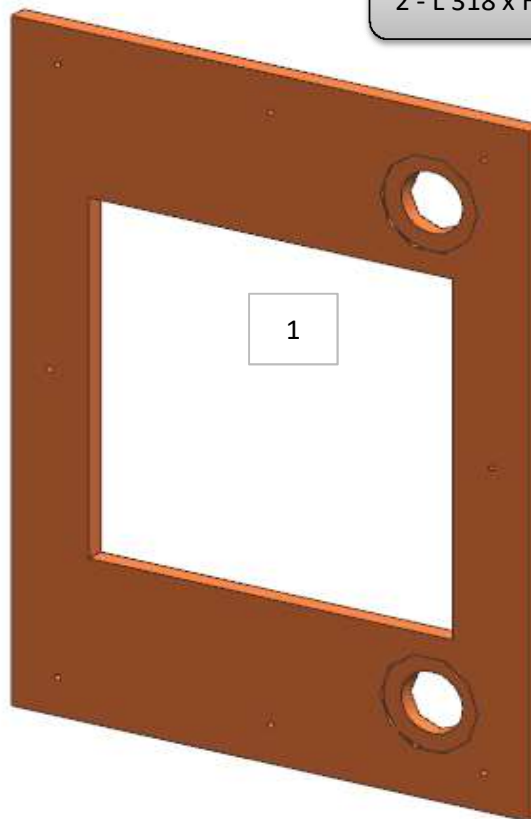

1

1 - L 336 x H 446 x sp 12  
2 - L 318 x H 50 x sp 12

**ELEMENTO DA MONTARE con:  
R01\_AAM01  
e spedire con un unico imballo**

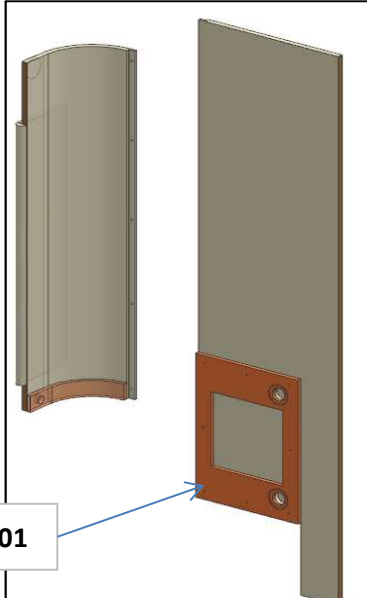

R01\_AAM01

# AZ68F

DA MAT. 203 REV. 29-04-2024

LOCALE	CODICE	DESCRIZIONE COMPONENTE	FINITURA	Q.TA	OPERATORE
CABINA ARMATORE	AZ68F-L01_AAO01	STRUTTURA BASSA A MURATA DX OPT	LACCATO BRONZO	1	Damiano

1 - L 2058 x H 50 x sp 12



ELEMENTO DA MONTARE con:  
**L01\_AAO01**  
e spedire con un unico imballo

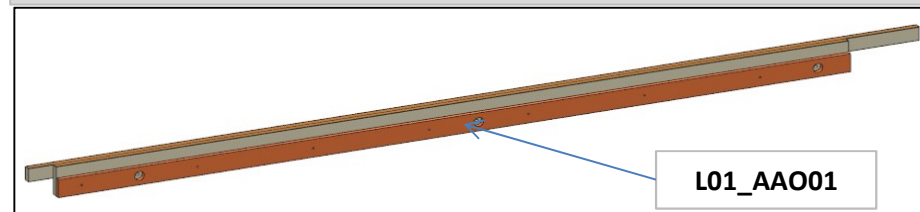

**consonni&c**

# AZ68F

DA MAT. 203 REV. 29-04-2024

LOCALE	CODICE	DESCRIZIONE COMPONENTE	FINITURA	Q.TA	OPERATORE
CABINA ARMATORE	AZ68F-L01_AAR01	COMODINO POPPA OPT	LACCATO BIANCO ARTICO	1	Damiano

1 - L 510 x H 81 x sp 32

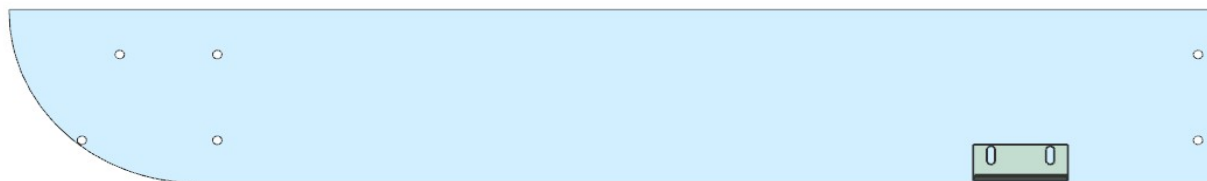

**ELEMENTO DA MONTARE con:**  
**R01\_AAR01**  
**AAR01**  
**L02\_AAR01**  
e spedire con un unico imballo

AAR01

L02\_AAR01

R01\_AAR01

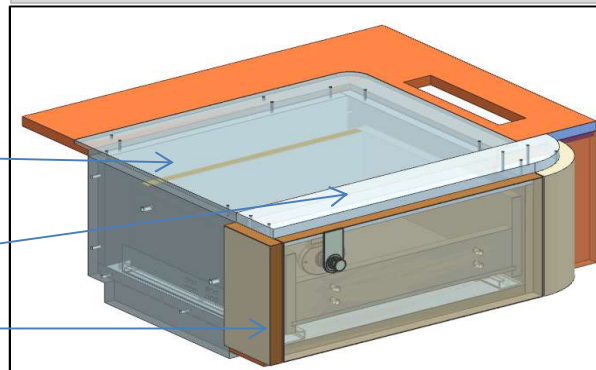

# AZ68F

DA MAT. 203 REV. 29-04-2024

LOCALE	CODICE	DESCRIZIONE COMPONENTE	FINITURA	Q.TA	OPERATORE
CABINA ARMATORE	AZ68F-L02_AAR01	COMODINO POPPA OPT	LACCATO BRONZO	2	Damiano

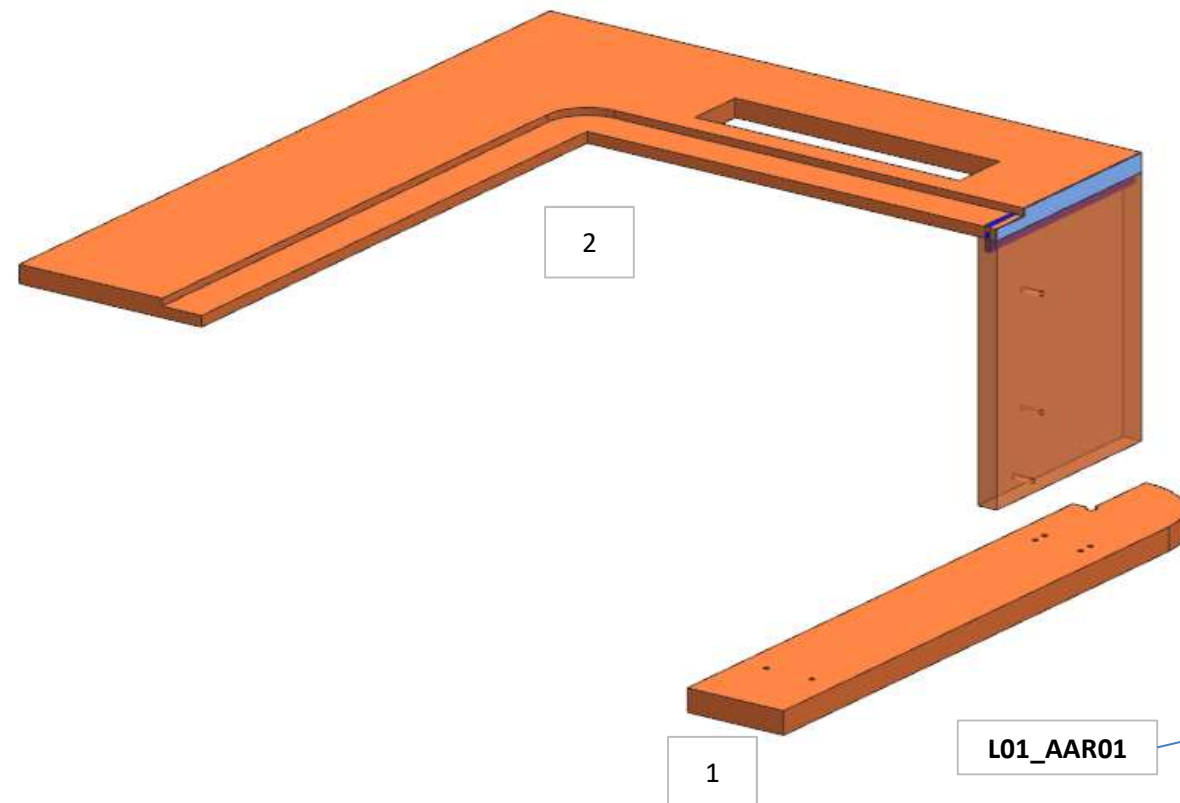

1 - L 490 x H 76 x sp 19  
2 - L 592 x H 223 x 468

**ELEMENTO DA MONTARE con:**  
**R01\_AAR01**  
**L01\_AAR01**  
**AAR01**  
**e spedire con un unico imballo**

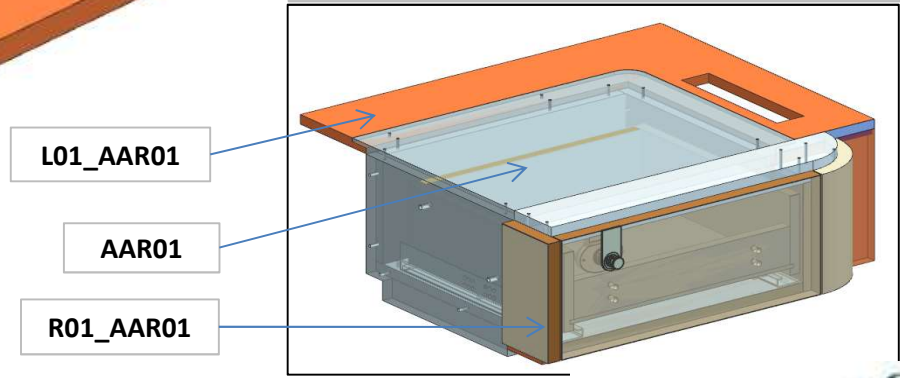

# AZ68F

DA MAT. 265 REV. 29-04-2024

LOCALE	CODICE	DESCRIZIONE COMPONENTE	FINITURA	Q.TA	OPERATORE
CABINA ARMATORE	AZ68F-L03_AAR01	COMODINO POPPA OPT	LACCATO MOGANO 100 GLOSS	4	Damiano

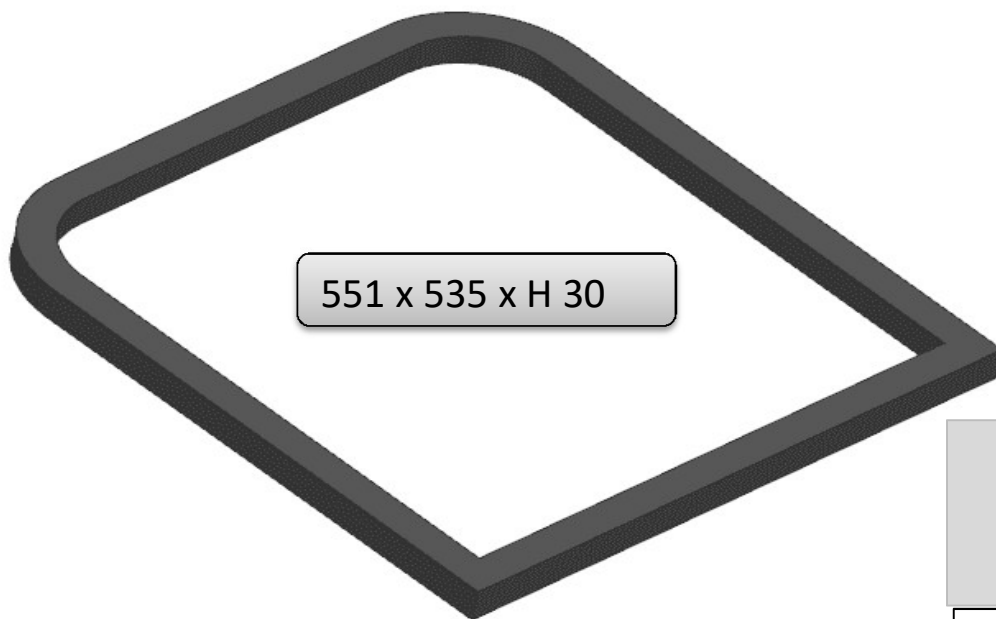

551 x 535 x H 30

ELEMENTO DA MONTARE con:  
**X01\_AAR01**  
e spedire con un unico imballo

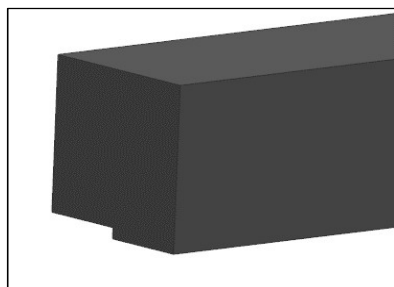

DETTAGLIO DI SEZIONE

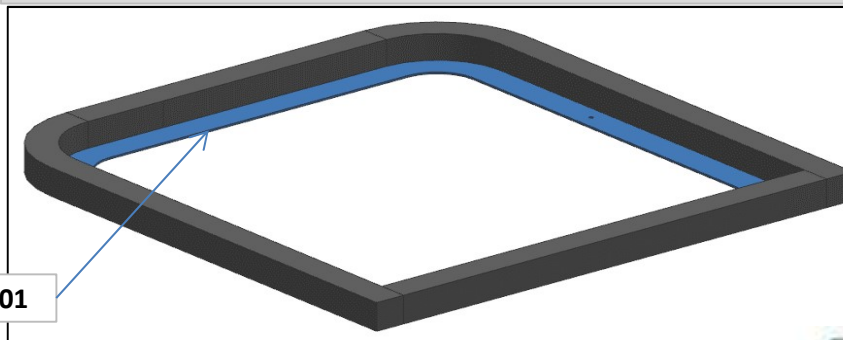

X01\_AAR01