

AZ68F

REV. 29-04-2024

LOCALE	CODICE	DESCRIZIONE COMPONENTE	FINITURA	Q.TA	OPERATORE
BAGNO ARMATORE	AZ68F-R01_WA01	MOBILE LAVELLO	OKOUME' BORDATO LASTRA	1	Damiano

1 - L.784 x H.269 x sp 15

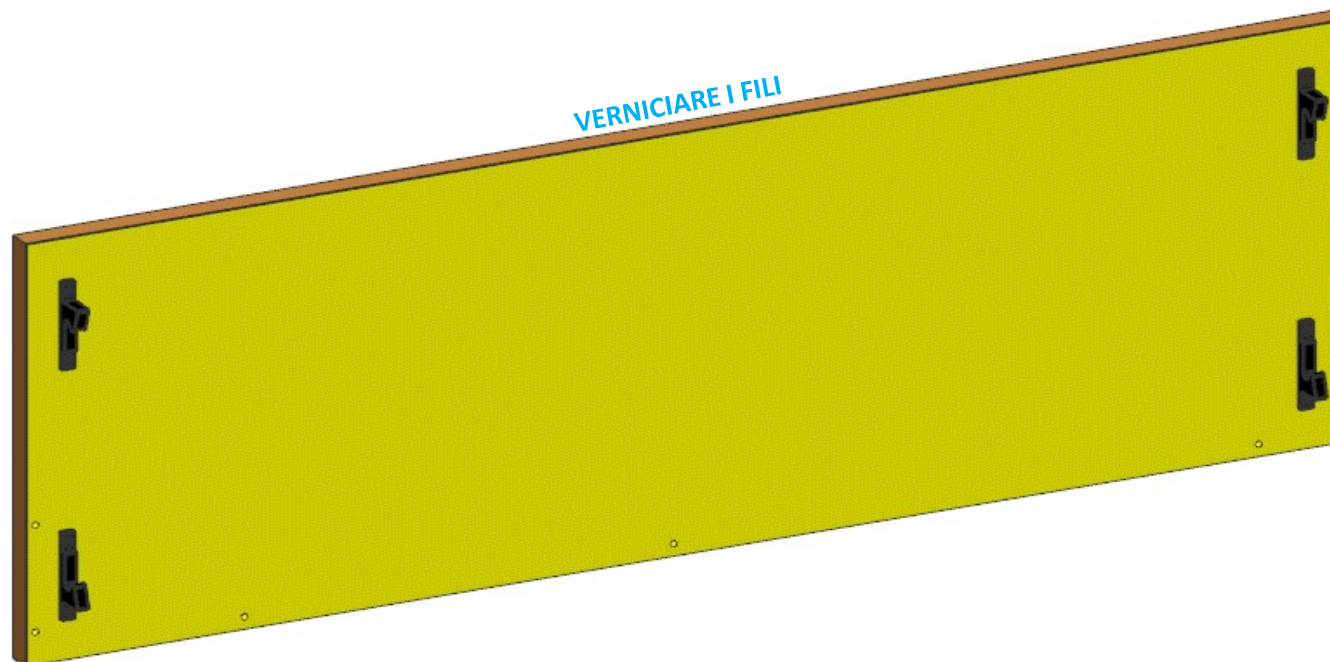

AZ68F

DA MAT. 265

REV. 29-04-2024

LOCALE	CODICE	DESCRIZIONE COMPONENTE	FINITURA	Q.TA	OPERATORE
BAGNO ARMATORE	AZ68F-R01_WB01	SEDUTA E RIVESTIMENTI DOCCIA	LASTRA IROKO DOGATO	8	Damiano

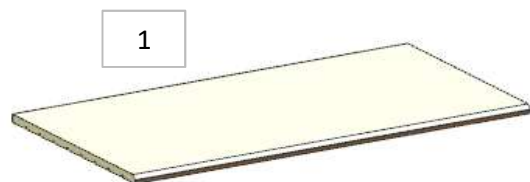

1



2



3

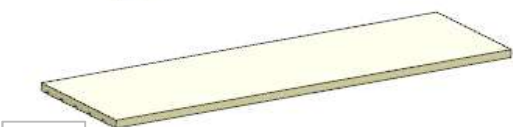

4

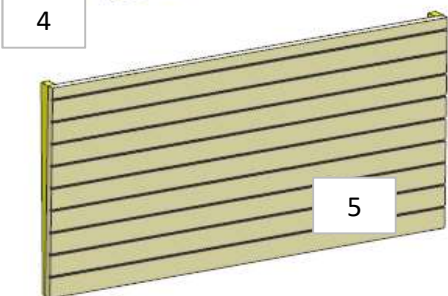

5

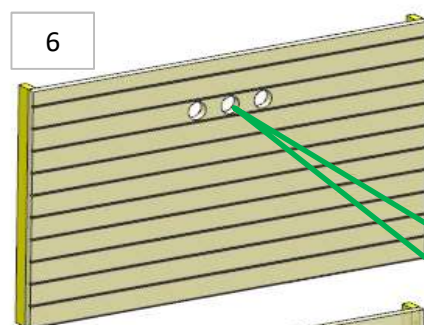

6

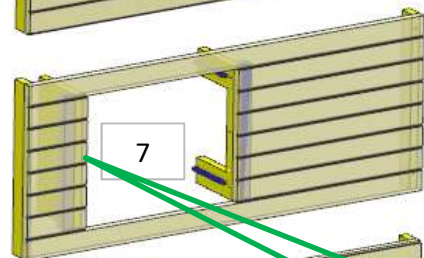

7

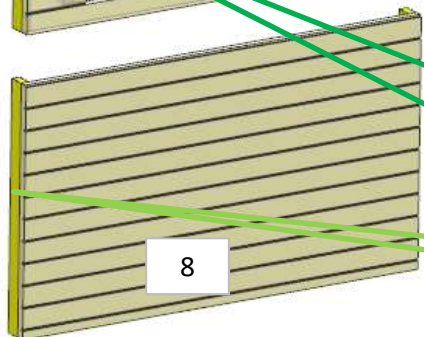

8

PZ 7 - PORTARE SPIGOLI A 90°

146 AGGIUNTI FORI

ID-1459
FINITURA CON OLIATURA
ISO AZ78F

146
AGGIUNTI GREZZI - DA
VERNICIARE ASSIEME A
IROKO

FISSARE GREZZI

PZ 3 DA RAGGIARE

- 1 - L. 781 x H.394 x sp 16
- 2 - L. 781 x H.348 x sp 16
- 3 - L. 781 x H.100
- 4 - L. 781 x H.238 x sp 16
- 5 - L.781x H 418 x sp 16
- 6 - L. 781 x H.472 x sp 16
- 7 - L. 781 x H.347 8x sp 16

DETTAGLIO RETRO N.7

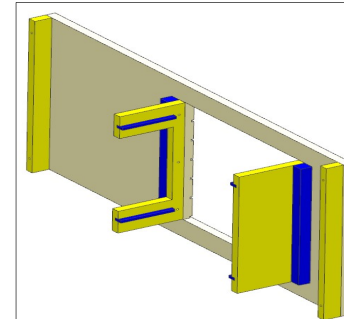

AZ68F

DA MAT. 216 REV. 29-04-2024

LOCALE	CODICE	DESCRIZIONE COMPONENTE	FINITURA	Q.TA	OPERATORE
BAGNO ARMATORE	AZ68F-R01_WC01	CIELINO LAVELLO	LASTRA CHIARA	1	Damiano

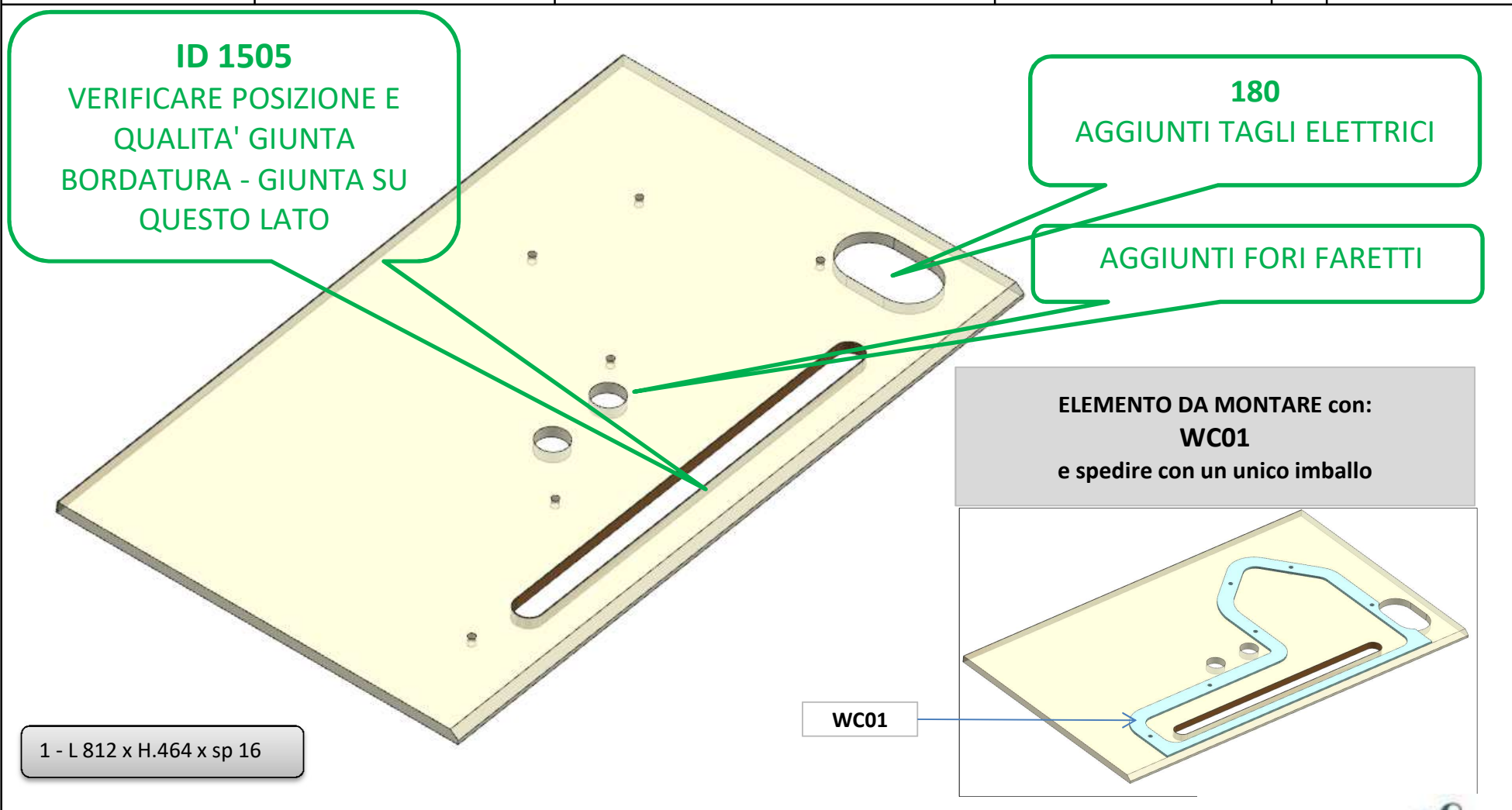

AZ68F

DA MAT. 228 REV. 29-04-2024

LOCALE	CODICE	DESCRIZIONE COMPONENTE	FINITURA	Q.TA	OPERATORE
BAGNO ARMATORE	AZ68F-R01_WL01	MOBILE STORAGE-OPT	LASTRA CHIARA	3	Damiano

- 1 - L.34 x H 242 x sp 16
- 2 - L 473 x H 239 x sp 16
- 3 - L.509 x H 242 x sp 16

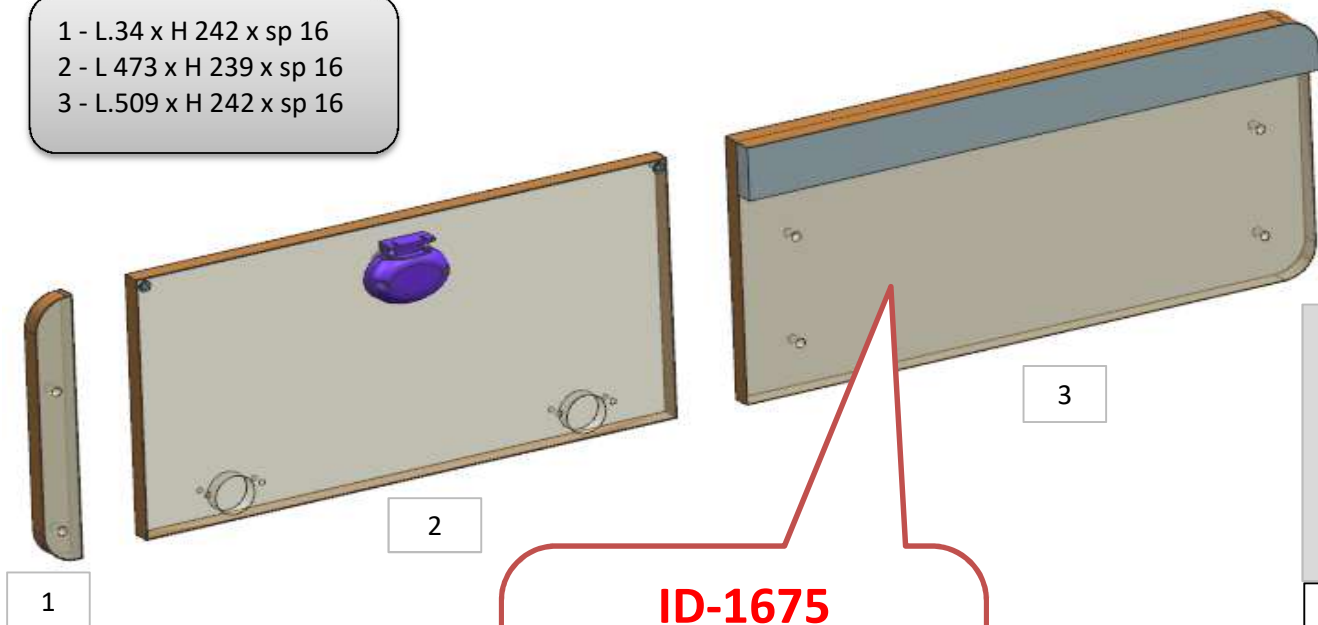

ID-1675
VERIFICARE
INSPESSIMENTO DI
TUTTO IL PANNELLO
FISSO (pz n° 3)

ELEMENTO DA MONTARE con:
WL01
L01_WL01
L02_WL01
e spedire con un unico imballo

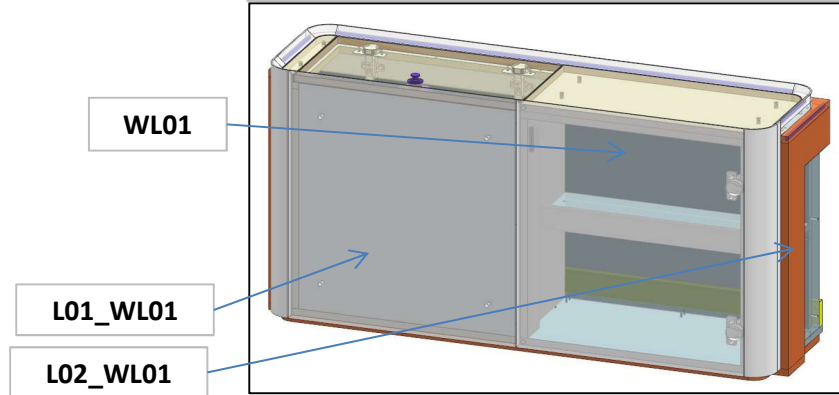

AZ68F

DA MAT. 233 REV. 29-04-2024

LOCALE	CODICE	DESCRIZIONE COMPONENTE	FINITURA	Q.TA	OPERATORE
BAGNO ARMATORE	AZ66F-R01_WP01	RIVESTIMENTO BASSO RETROWC VAR	LASTRA CHIARA	5	Damiano

- 1 - L.816 x H 187 x sp 16
- 2 - 4 - L 187 x H 166 x sp 16
- 3 - L.684 x H 166 x sp 16
- 5 - L 716 x H 187 x sp 16

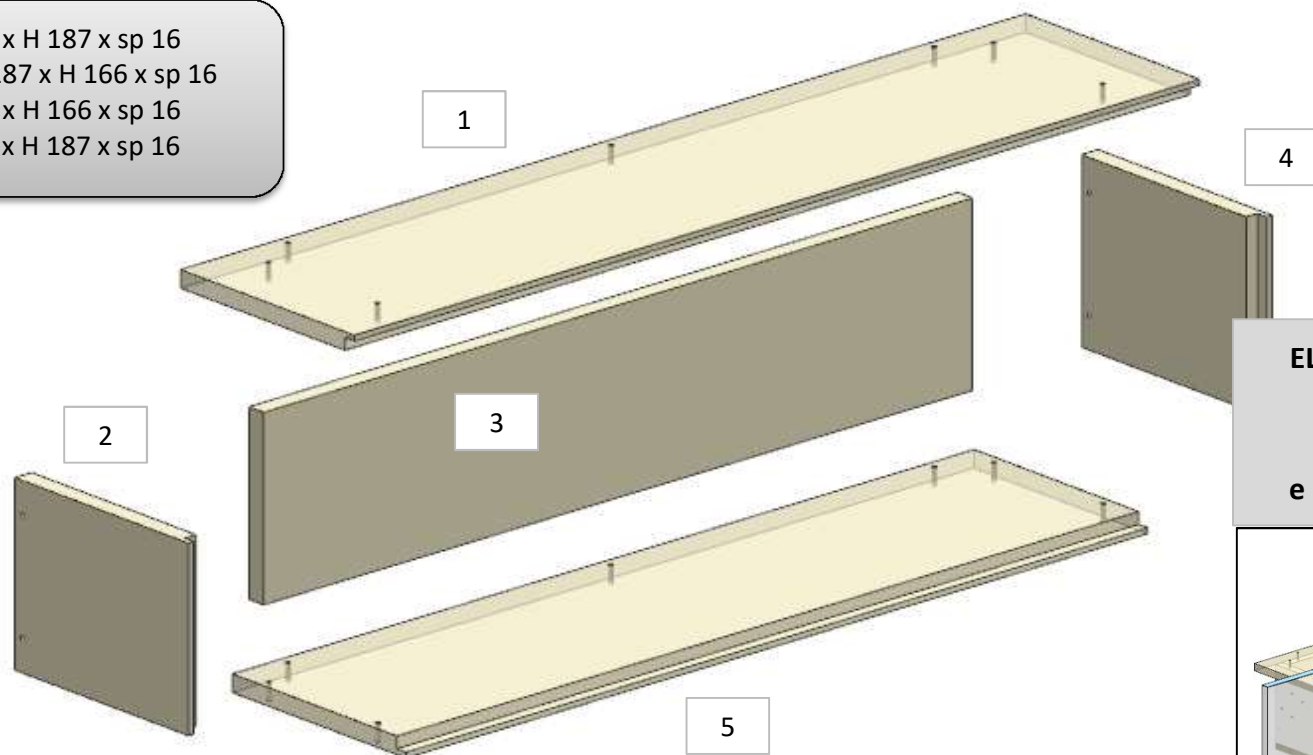

ELEMENTO DA MONTARE con:
L01_WP01
A01_WP01
e spedire con un unico imballo

FERRAMENTA:

- N° 3 - SPINE 8x20 mm
- N° 6 - FITLOCK MASCHIO

A01_WP01

L01_WP01

