

AZ68F

REV. 29-04-2024

LOCALE	CODICE	DESCRIZIONE COMPONENTE	FINITURA	Q.TA	OPERATORE
SALONE A POPPA	AZ68F-SSA01	PARETE DIVISORIA LATO POPPA	OKOUME' GREZZO	2	Dante

1 - L.1515 x H.1729 x sp 15
2 - L.577 x H.318 x sp 30

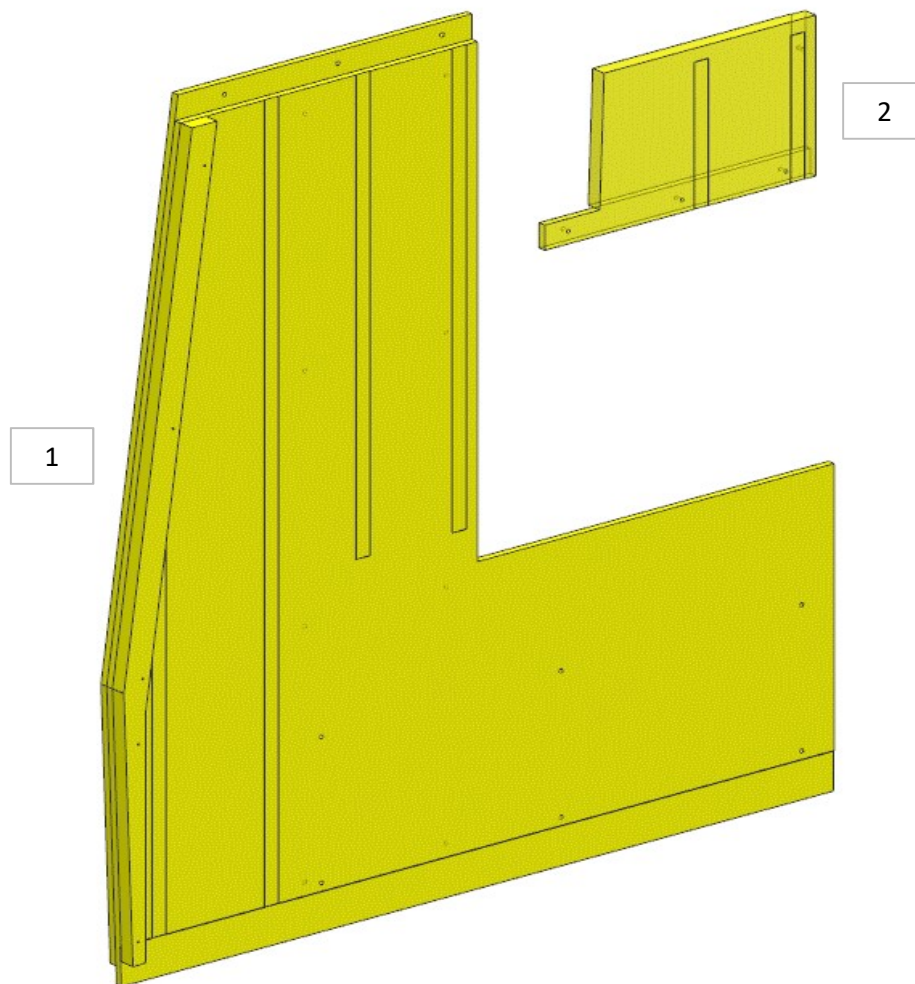

FERRAMENTA:

N° 6 - FITLOCK MASCHIO
N° 6 - FITLOCK FEMMINA
N° 20 - BUSSOLA ZAMA 6MA

AZ68F

DA MAT. 265 REV. 29-04-2024

LOCALE	CODICE	DESCRIZIONE COMPONENTE	FINITURA	Q.TA	OPERATORE
SALONE A POPPA	AZ68F-SSC01	MURATA BASSA DX PRUA	OKOUME\GREZZO VER. ANTI ROMBO	4	Damiano

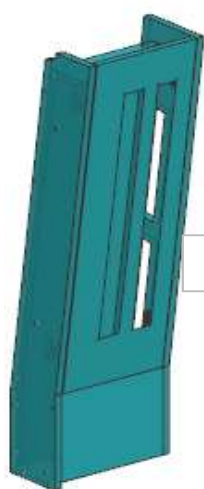

3

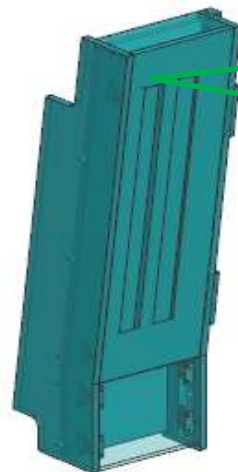

4

MOD. INT.
PLENUM DIVISO DA STRUTTURA.
VERNICIARE CON ANTI-ROMBO

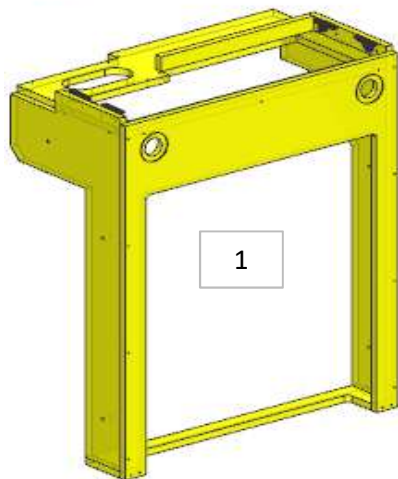

1

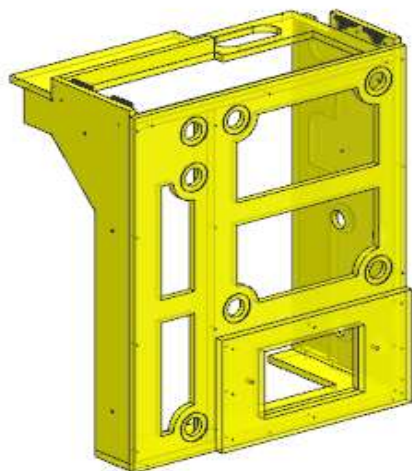

2

FERRAMENTA:

- N° 20 - KEKU FRONTALE
- N° 6 - BUSSOLA ZAMA 6MA
- N° 15 - VITI 6MA
- N° 13 - FITLOCK MASCHIO
- N° 13 - FITLOCK FEMMINA

AZ68F

DA MAT. 203 REV. 13-09-2021

LOCALE	CODICE	DESCRIZIONE COMPONENTE	FINITURA	Q.TA	OPERATORE
SALONE A POPPA	AZ68F-I01_SSC01	MURATA BASSA DX PRUA	OKOUME' GREZZO	1	Dante

1 - L 313 x H.416 x sp 30

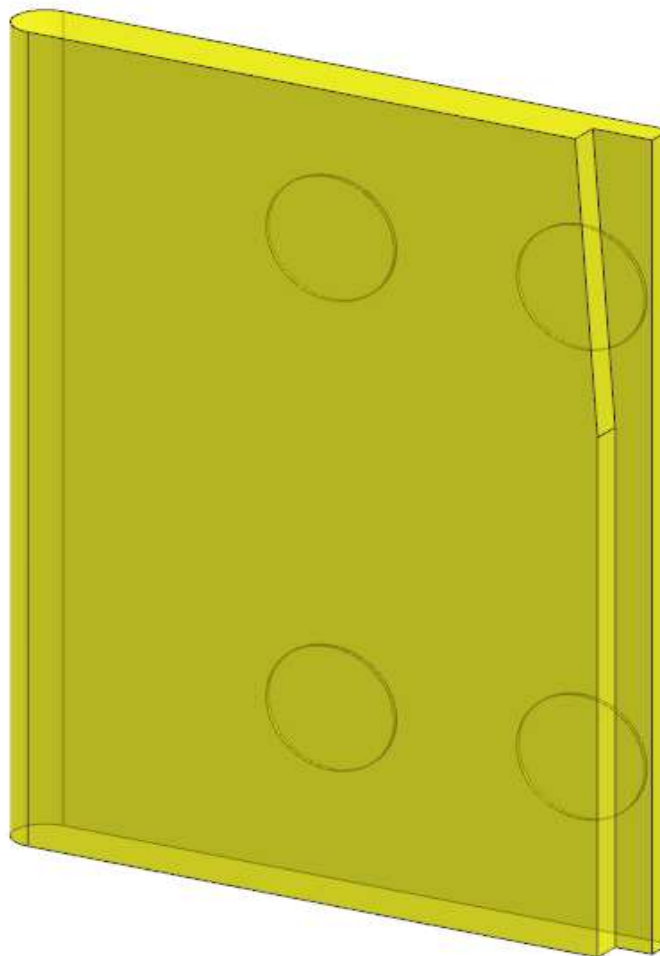

AZ68F

DA MAT. 203 REV. 13-09-2021

LOCALE	CODICE	DESCRIZIONE COMPONENTE	FINITURA	Q.TA	OPERATORE
SALONE A POPPA	AZ68F-I01_SSE01	CASSAPANCA DX	OKOUME' GREZZO	2	Dante

1 - L.387 x H.250 x sp 6
2 - L.505 x H.387 x sp 6

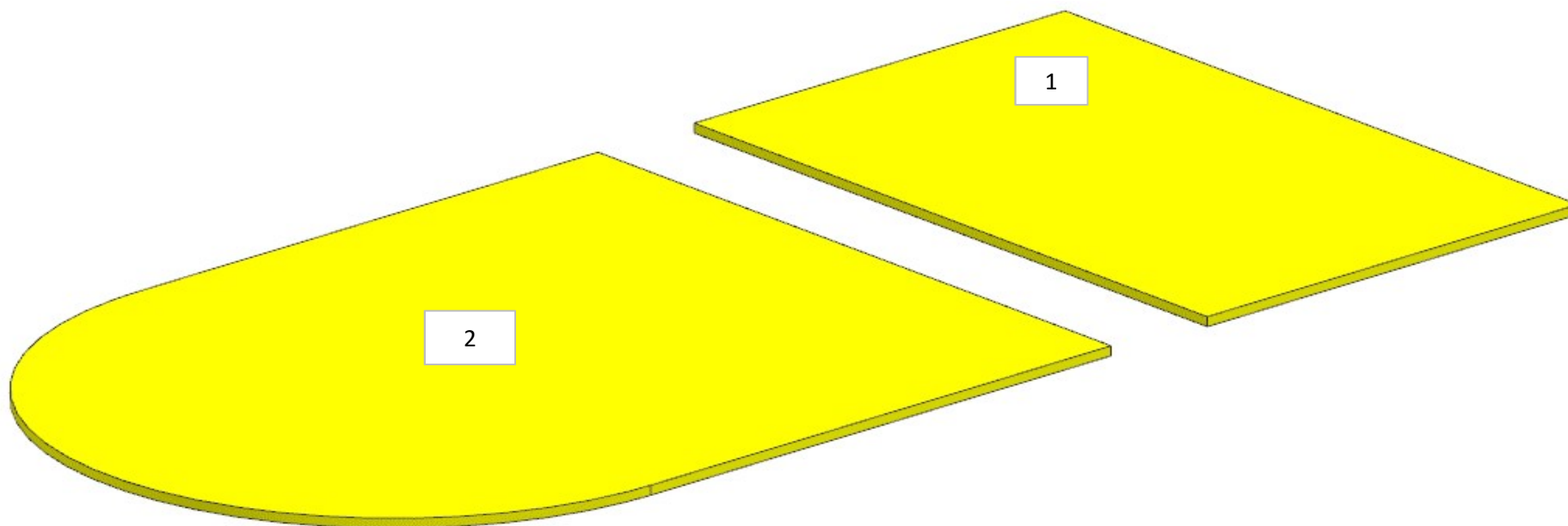

AZ68F

DA MAT.233

REV. 29-04-2024

LOCALE	CODICE	DESCRIZIONE COMPONENTE	FINITURA	Q.TA	OPERATORE
SALONE A POPPA	AZ68F-SSF01	COLONNA PLENUM DX PRUA	OKOUME\GREZZO VER. ANTI ROMBO	2	Dante

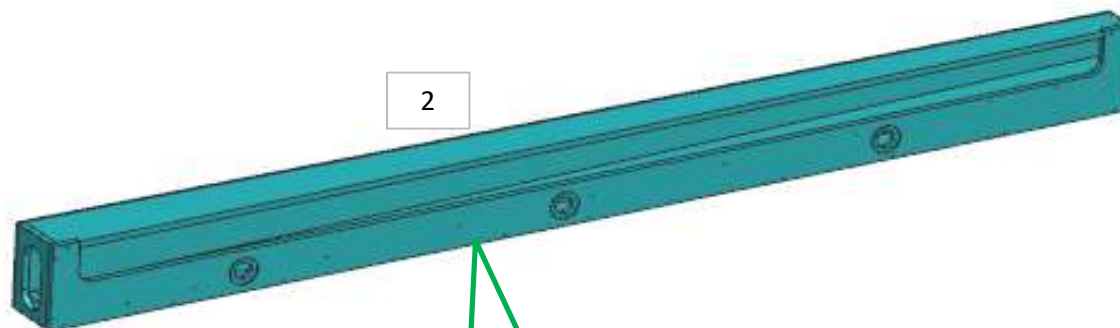
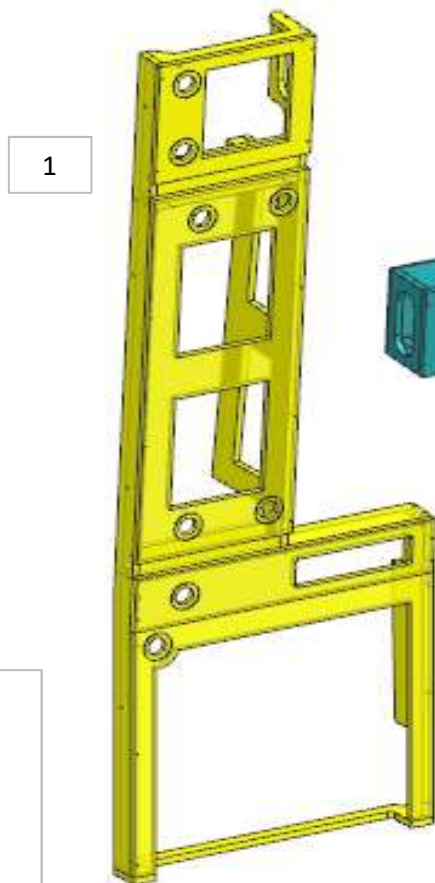

MOD. INT.
PLENUM DIVISO DA STRUTTURA.
VERNICIARE CON **ANTI-ROMBO**

FERRAMENTA:

- N° 2 - BUSSOLA ZAMA 6MA
- N° 6 - VITI 6MA
- N° 10 - FITLOCK MASCHIO
- N° 10 - FITLOCK FEMMINA

AZ68F

DA MAT.212 REV. 29-04-2024

LOCALE	CODICE	DESCRIZIONE COMPONENTE	FINITURA	Q.TA	OPERATORE
SALONE A POPPA	AZ68F-SSG01	STRUTTURA MURATA BASSA DX	OKOUME' GREZZO	1	Dante

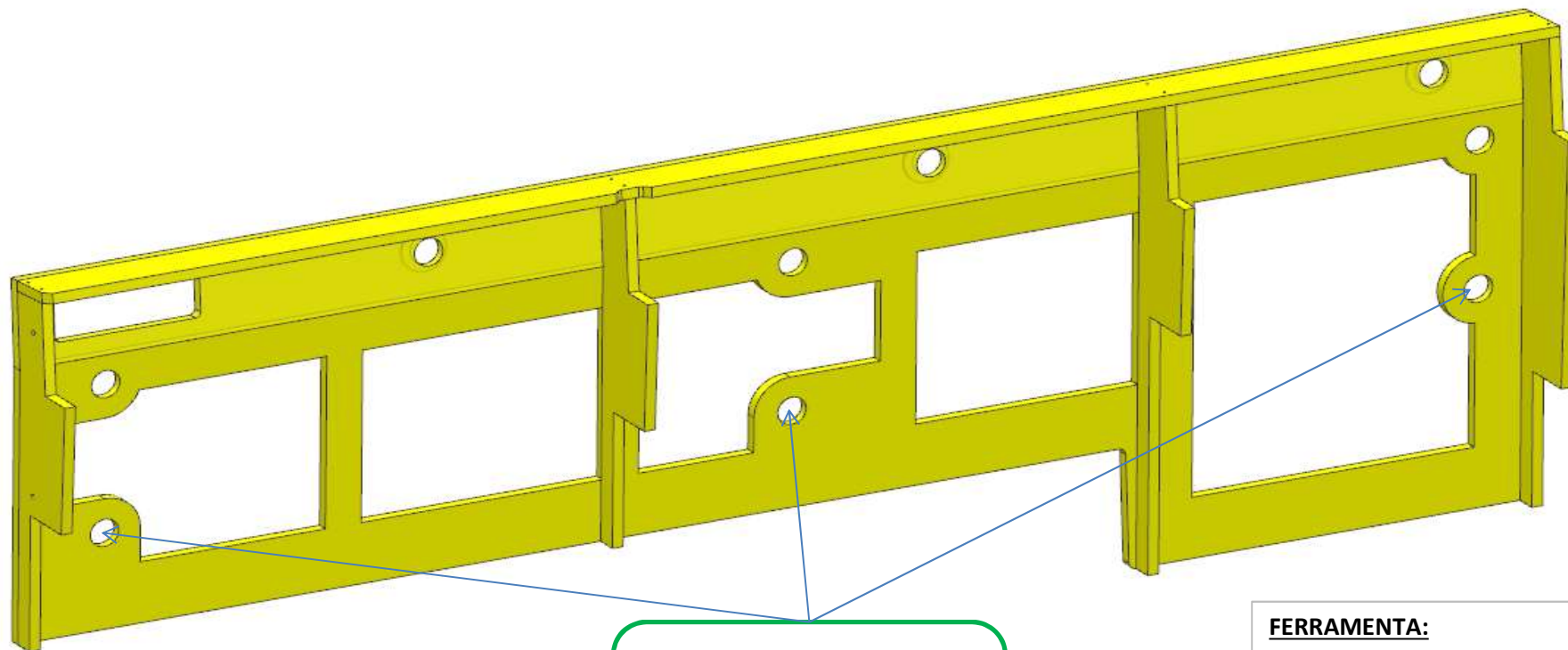

25 (step1)
AGGIUNTI FORI
FITLOCK

FERRAMENTA:

- N° 2 - BUSSOLA ZAMA 6MA
- N° 2 - VITI 6MA
- N° 3 - FITLOCK MASCHIO
- N° 3 - FITLOCK FEMMINA

AZ68F

DA MAT.212 REV. 13-09-2021

LOCALE	CODICE	DESCRIZIONE COMPONENTE	FINITURA	Q.TA	OPERATORE
SALONE A POPPA	AZ68F-I01_SSG01	STRUTTURA MURATA BASSA DX	OKOUME' GREZZO	2	Dante

1 - L 3005 x H 152 x sp 15 mm
2 - L 2696 x H 297 x sp 15 mm

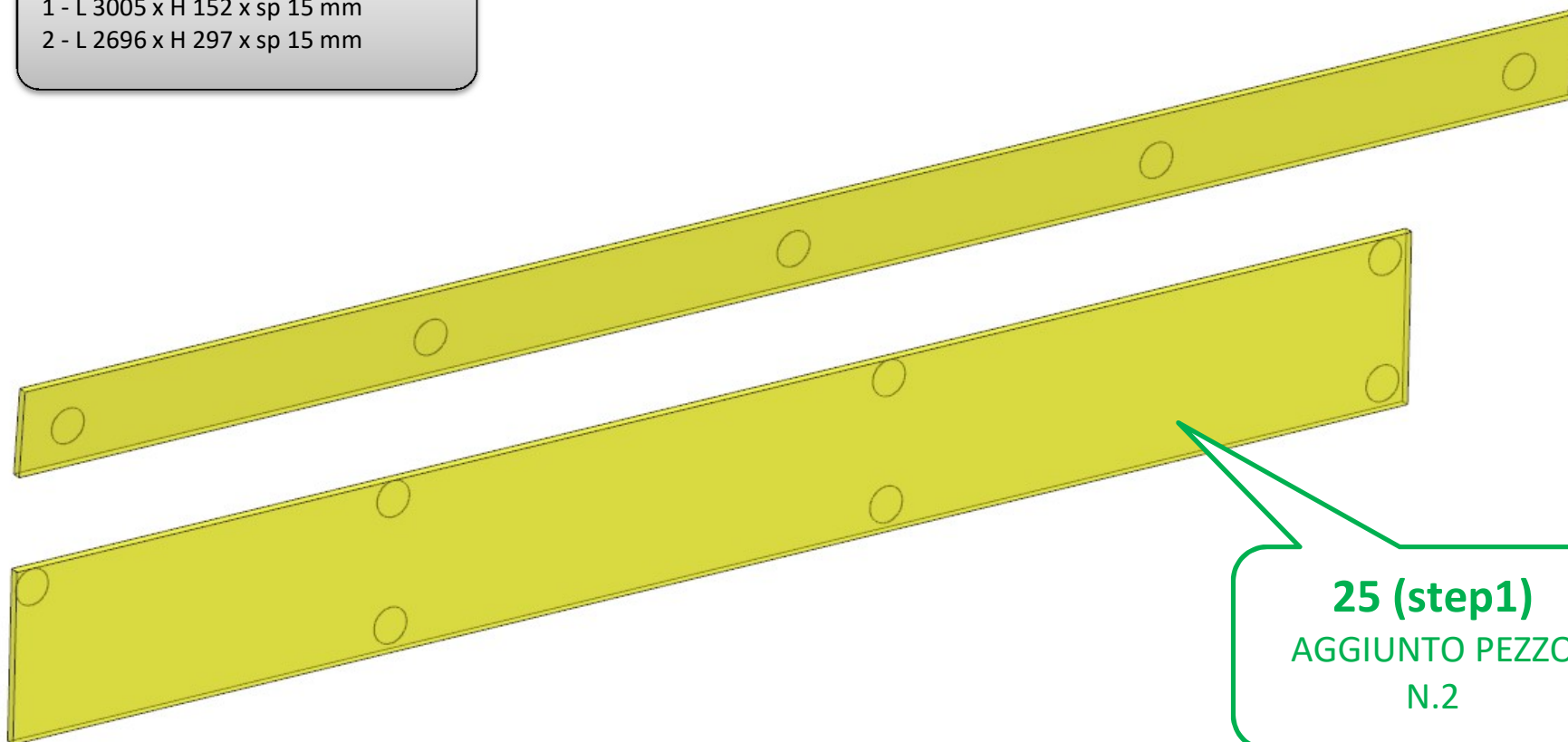

AZ68F

DA MAT. 203 REV. 29-04-2024

LOCALE	CODICE	DESCRIZIONE COMPONENTE	FINITURA	Q.TA	OPERATORE
SALONE A POPPA	AZ68F-SSH01	COLONNA POPPA MURATA DX	OKOUME' GREZZO	1	Dante

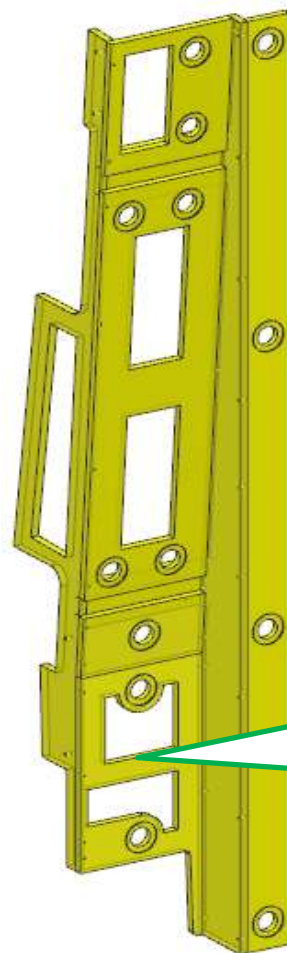

1-2
MODIFICATA
STRUTTURA E
AGGIUNTO
FITLOCK PER
NUOVO
IMPOTTITO

FERRAMENTA:

- N° 2 - BUSSOLA ZAMA 6MA
- N° 2 - VITI 6MA
- N° 13 - FITLOCK MASCHIO
- N° 13 - FITLOCK FEMMINA

AZ68F

DA MAT. 203 REV. 13-09-2021

LOCALE	CODICE	DESCRIZIONE COMPONENTE	FINITURA	Q.TA	OPERATORE
SALONE A POPPA	AZ66F-I01_SSH01	COLONNA POPPA MURATA DX	OKOUME' GREZZO	1	Dante

1 - L.305 x H 398 x sp 15

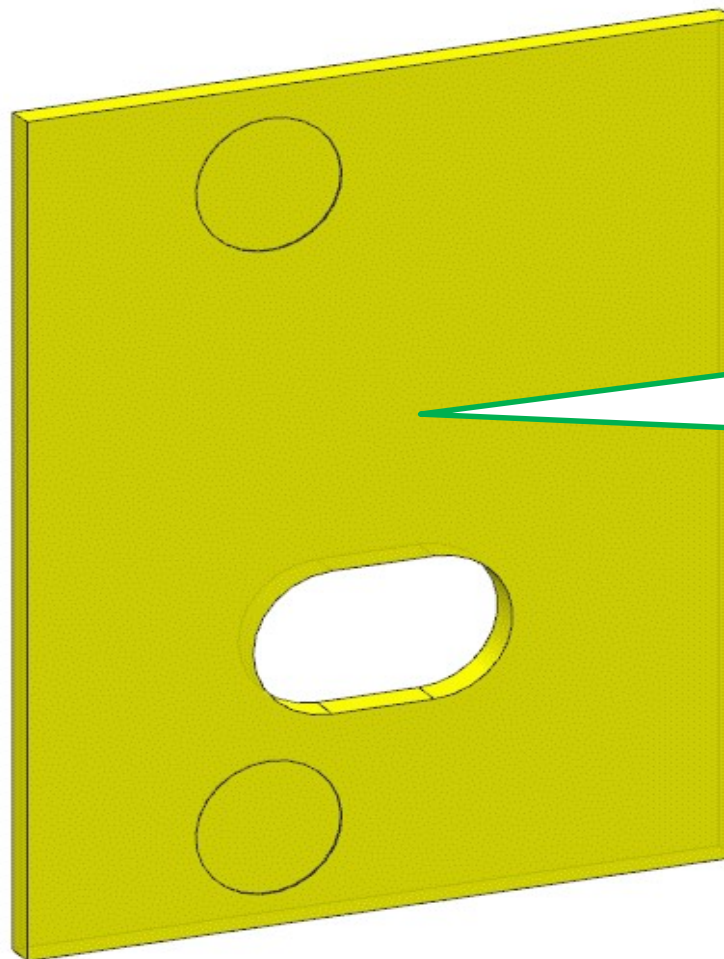

1-2
AGGIUNTO
IMBOTTITO E FORO
PER PRESA

AZ68F

DA MAT. 265 REV. 29-04-2024

LOCALE	CODICE	DESCRIZIONE COMPONENTE	FINITURA	Q.TA	OPERATORE
SALONE A POPPA	AZ68F-SSM01	MURATA BASSA SX PRUA	OKOUME\GREZZO VER. ANTI ROMBO	3	Damiano

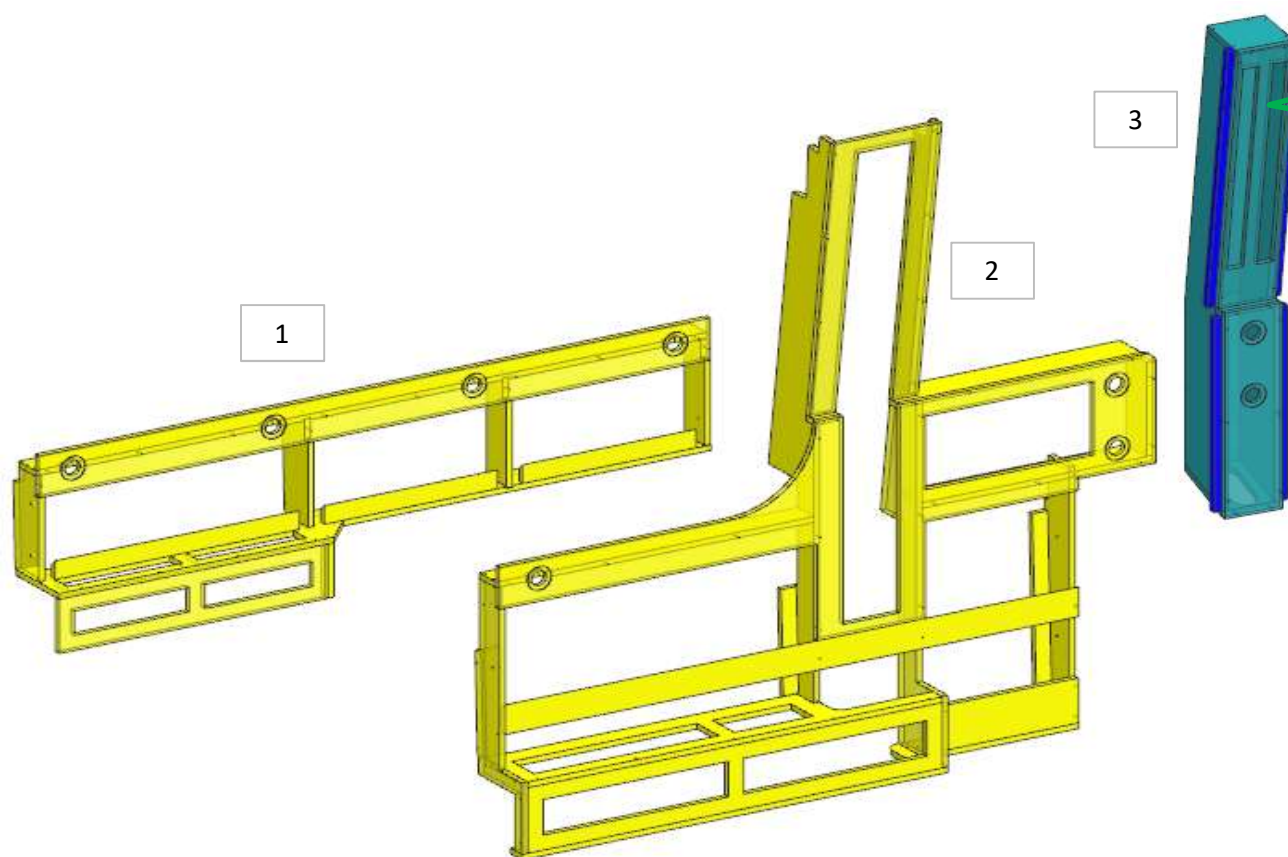

MOD. INT.
PLENUM DIVISO DA
STRUTTURA.
VERNICIARE CON
ANTI-ROMBO

FERRAMENTA:

- N° 2 - BUSSOLA ZAMA 6MA
- N° 4 - VITI 6MA
- N° 9 - FITLOCK MASCHIO
- N° 9 - FITLOCK FEMMINA

AZ68F

DA MAT. 265 REV. 29-04-2024

LOCALE	CODICE	DESCRIZIONE COMPONENTE	FINITURA	Q.TA	OPERATORE
SALONE A POPPA	AZ68F-X01_SSM01	MURATA BASSA SX PRUA	LAMINATO NERO	2	Damiano

- 1 - L 1732 x H 44 x sp 2
- 2 - SVILUPPO L 1877 x H 44 x sp 2

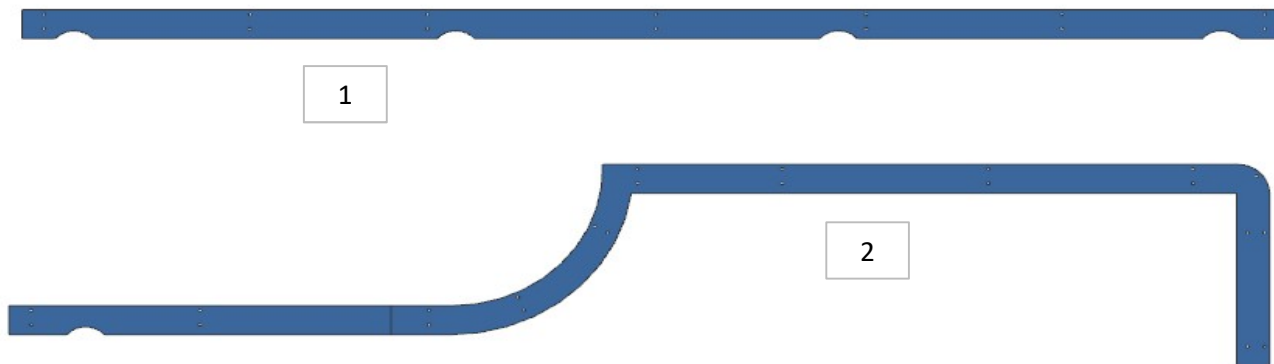

AZ68F

DA MAT. 212 REV. 13-09-2021

LOCALE	CODICE	DESCRIZIONE COMPONENTE	FINITURA	Q.TA	OPERATORE
SALONE A POPPA	AZ68F-I01_SSM01	MURATA BASSA SX PRUA	OKOUME' GREZZO	4	Dante

- 1 - L.1727 x H 460 x sp 10mm
- 2 - L.1727 x H 40 x sp 6mm
- 3 - L.1723 x H 670 x sp 10mm
- 4 - L.824 x H.193 x sp 6

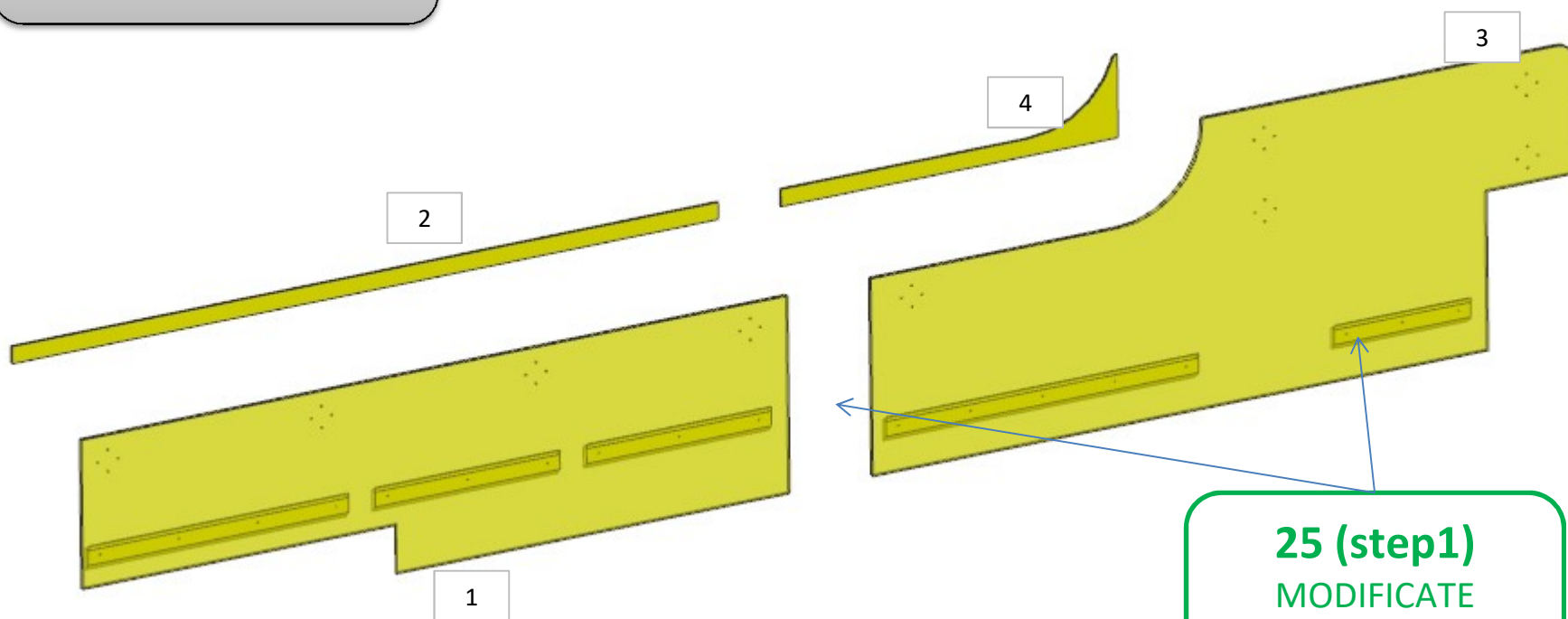

25 (step1)
MODIFICATE
DIMENSIONI