

# AZ68F

DA MAT. 265 REV. 29-04-2024

LOCALE	CODICE	DESCRIZIONE COMPONENTE	FINITURA	Q.TA	OPERATORE
FRONTE MARCIA	AZ68F-MF_FB01\FB02\FB03	MOBILE Q.E. SCALE			Damiano

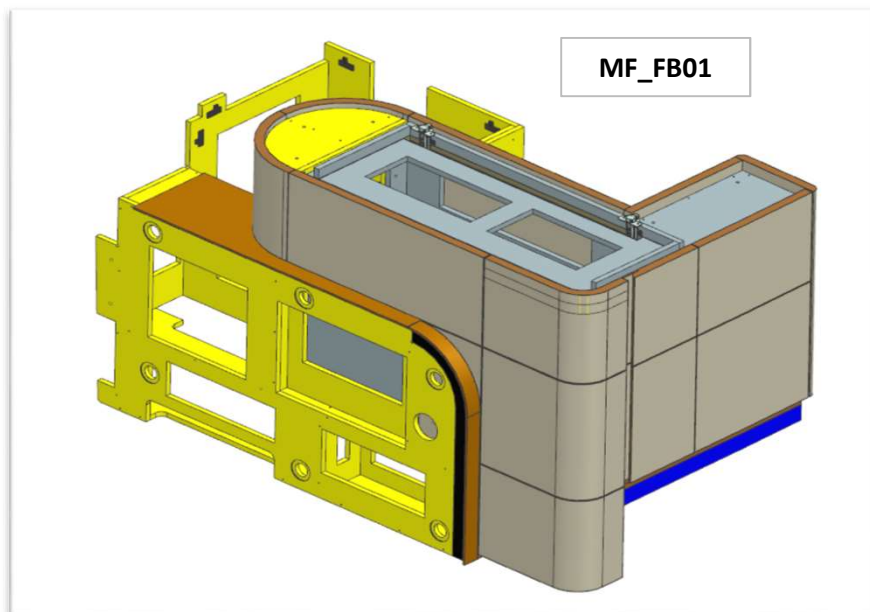

## FERRAMENTA:

- N° 4 - CERNIERE INVISIBILI
- N° 5 - CERNIERA PIANA
- N° 3 - BASETTE H6
- N° 20 - ANKOR BORGHI
- N° 2 - GOMMINO PARACOLPO
- N° 6 - KEKU FRONTALE PARTE PANNELLO
- N° 6 - KEKU PARTE TELAIO
- N° 38 - VITI 6MA TB
- N° 2 - VITI 6MA TS
- N° 47 - BUSSOLE ZAMA 6MA
- N° 1 - CALAMITA NERA
- N° 1 - RISCONTRO CALAMITA NERA
- N° 6 - FITLOCK MASCHIO

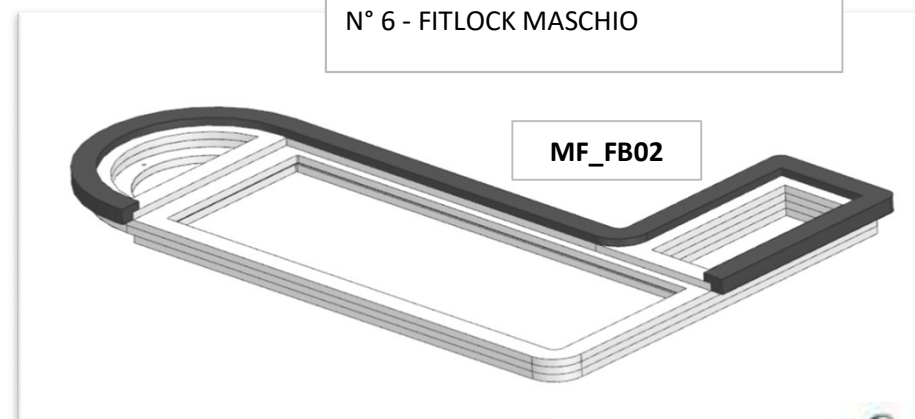

# AZ68F

DA MAT. 265 REV. 29-04-2024

LOCALE	CODICE	DESCRIZIONE COMPONENTE	FINITURA	Q.TA	OPERATORE
FRONTE MARCIA	AZ68F-FB01	MOBILE Q.E. SCALE	OKOUME' GREZZO	3	Damiano

## FERRAMENTA:

- N° 4 - CERNIERE INVISIBILI
- N° 5 - CERNIERA PIANA
- N° 3 - BASETTE H6
- N° 20 - ANKOR BORGHI
- N° 2 - GOMMINO PARACOLPO
- N° 6 - KEKU FRONTALE PARTE PANNELLO
- N° 6 - KEKU PARTE TELAIO
- N° 38 - VITI 6MA TB
- N° 2 - VITI 6MA TS
- N° 47 - BUSSOLE ZAMA 6MA
- N° 1 - CALAMITA NERA
- N° 1 - RISCONTRO CALAMITA NERA
- N° 6 - FITLOCK MASCHIO

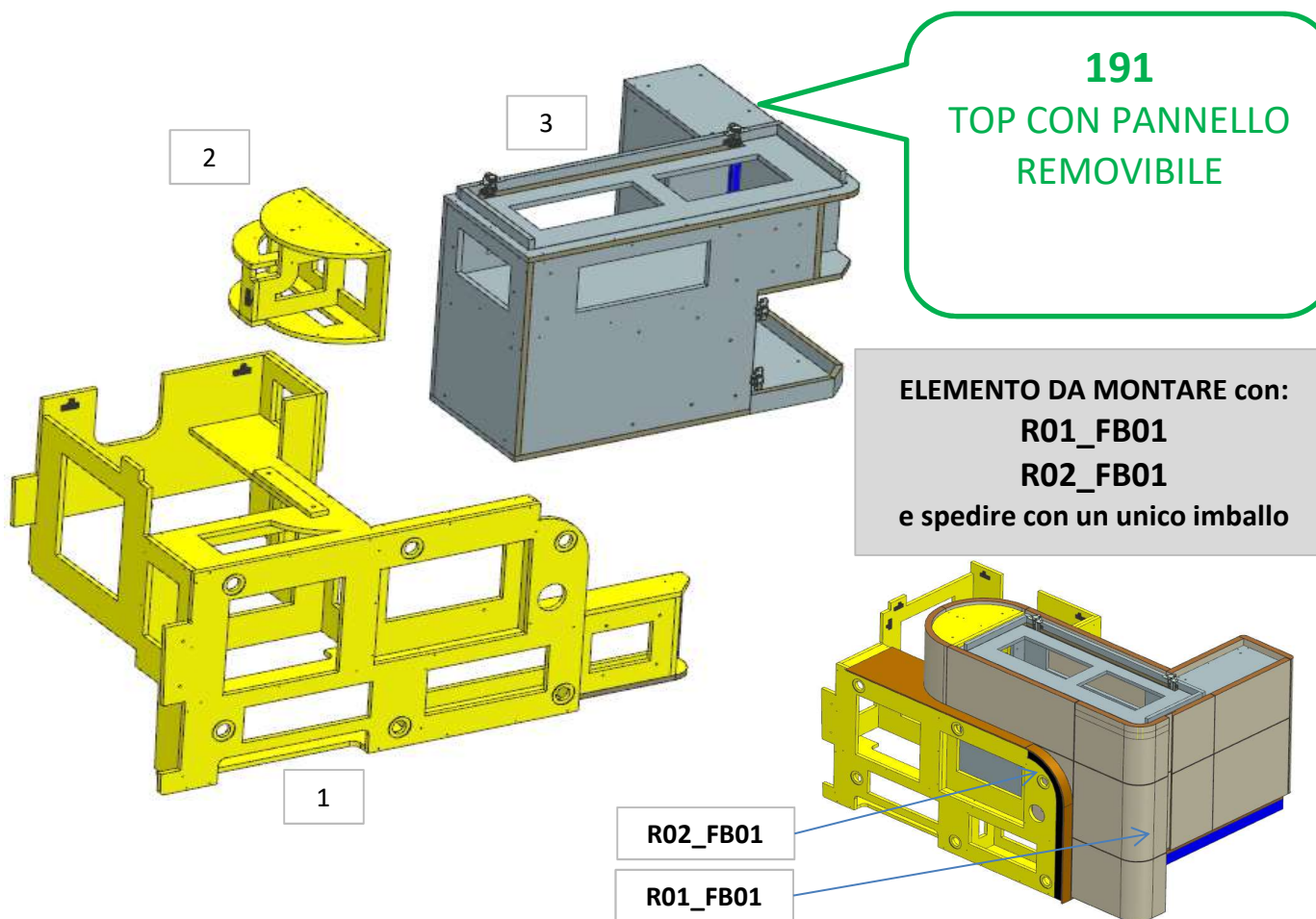

**191**  
TOP CON PANNELLO  
REMOVIBILE

ELEMENTO DA MONTARE con:  
**R01\_FB01**  
**R02\_FB01**  
e spedire con un unico imballo

# AZ68F

DA MAT. 265 REV. 29-04-2024

LOCALE	CODICE	DESCRIZIONE COMPONENTE	FINITURA	Q.TA	OPERATORE
FRONTE MARCIA	AZ68F-R01_FB01	MOBILE Q.E. SCALE	LASTRA CHIARA	13	Damiano

- 1 - sv .747 x H 281 x sp 25mm
- 2 - L 965 x H 829 x sp 25mm
- 3 - L 653 x H 282 x sp 25mm
- 4 - L 204 x H 672 x sp 25mm
- 5 - sv. 457 x H 282 x sp 25mm
- 6 - sv.457 x H 368 x sp 25mm
- 7 - sv.457 x H 287 x sp 25mm
- 8 - L 54 x H 652 x sp 6mm
- 9 - L 723 x H 652 x sp 25mm
- 10 - L 230 x H 652 x sp 25mm
- 11 - L 415 x H 652 x sp 25mm
- 12 - L 400 x H 652 x sp 25mm

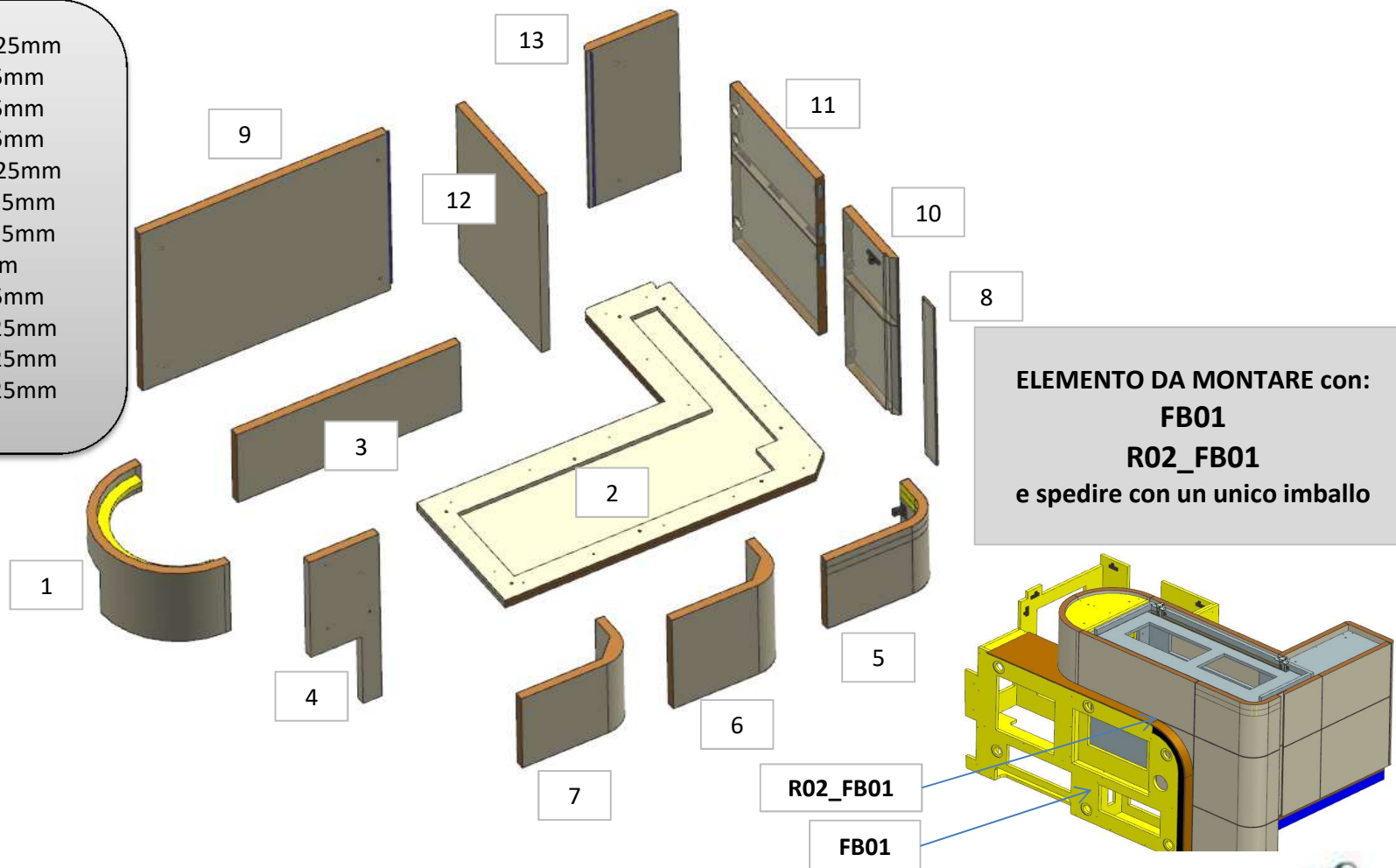

# AZ68F

DA MAT. 265 REV. 29-04-2024

LOCALE	CODICE	DESCRIZIONE COMPONENTE	FINITURA	Q.TA	OPERATORE
FRONTE MARCIA	AZ68F-R02_FB01	MOBILE Q.E. SCALE	LASTRA TEAK	2	Damiano

1 - L.919 x H.257 x sp 6  
2 - L.789 x H.67 x 46,5

**95**  
AGGIUNTO  
SPESSORE A  
QUESTO PEZZO



ELEMENTO DA MONTARE con:  
**R01\_FB01**  
**FB01**  
e spedire con un unico imballo

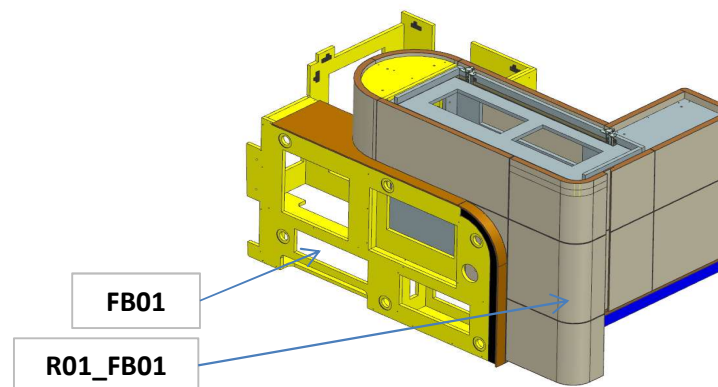

# AZ68F

DA MAT. 265 REV. 29-04-2024

LOCALE	CODICE	DESCRIZIONE COMPONENTE	FINITURA	Q.TA	OPERATORE
FRONTE MARCIA	AZ68F-L01_FB01	MOBILE Q.E. SCALE	LACCATO BIANCO ARTICO	2	Damiano

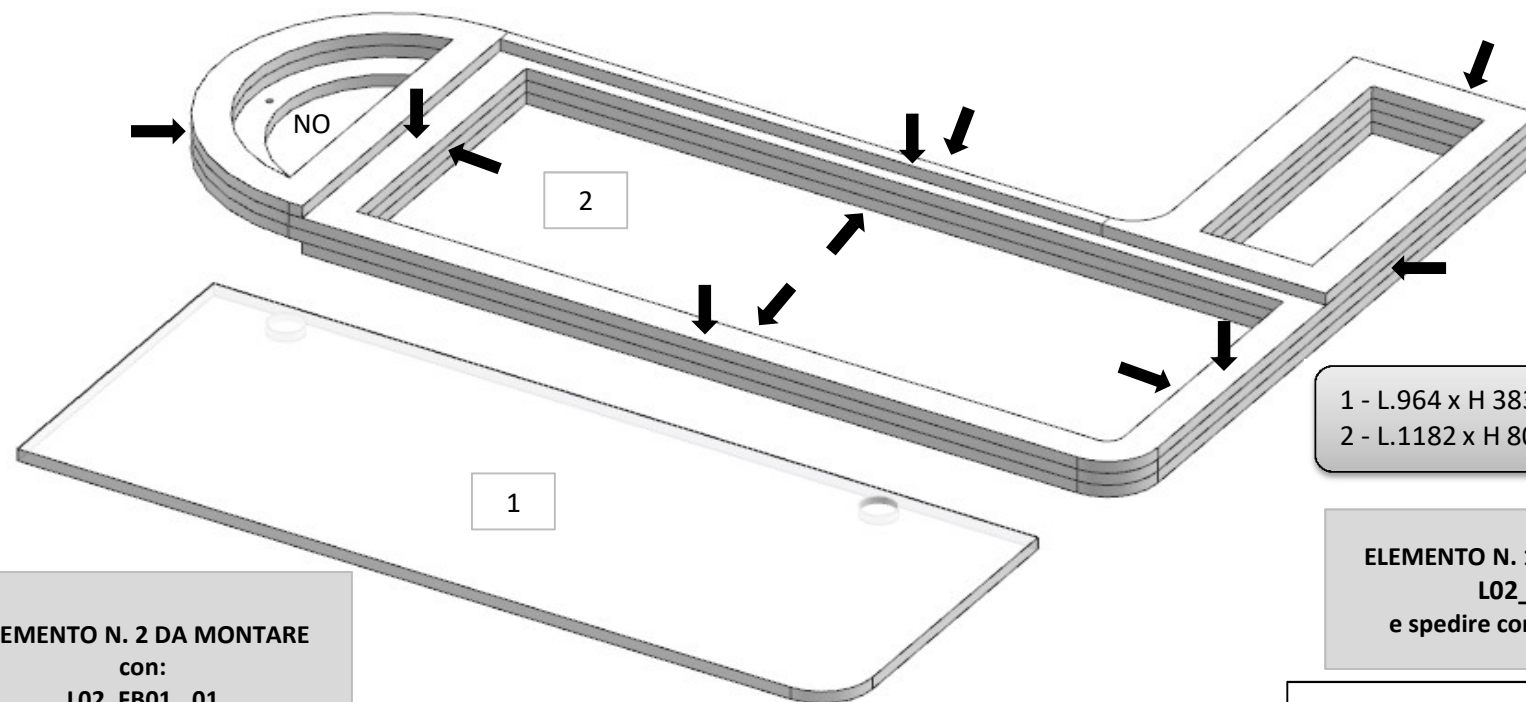

1 - L.964 x H 383 x sp 16mm  
2 - L.1182 x H 803 x sp 64mm

ELEMENTO N. 1 DA MONTARE con:  
L02\_FB01\_02  
e spedire con un unico imballo

ELEMENTO N. 2 DA MONTARE con:  
L02\_FB01\_01  
e spedire con un unico imballo

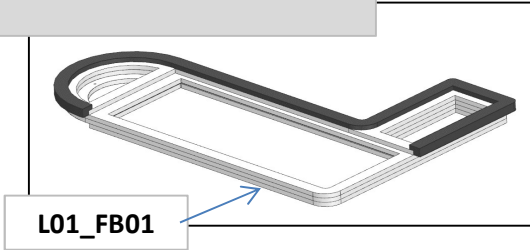

\* faccia dove viene applicata la finitura  
↓ filo dove viene applicata la finitura

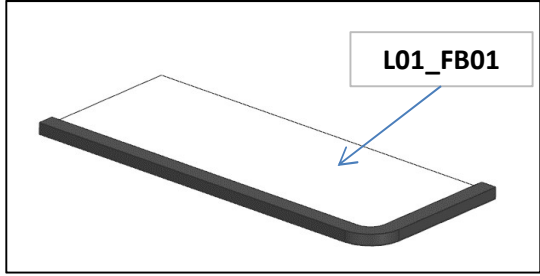

# AZ68F

DA MAT. 265 REV. 29-04-2024

LOCALE	CODICE	DESCRIZIONE COMPONENTE	FINITURA	Q.TA	OPERATORE
FRONTE MARCIA	AZ68F-L02_FB01	MOBILE Q.E. SCALE	LACCATO MOGANO 100 GLOSS	2	Damiano

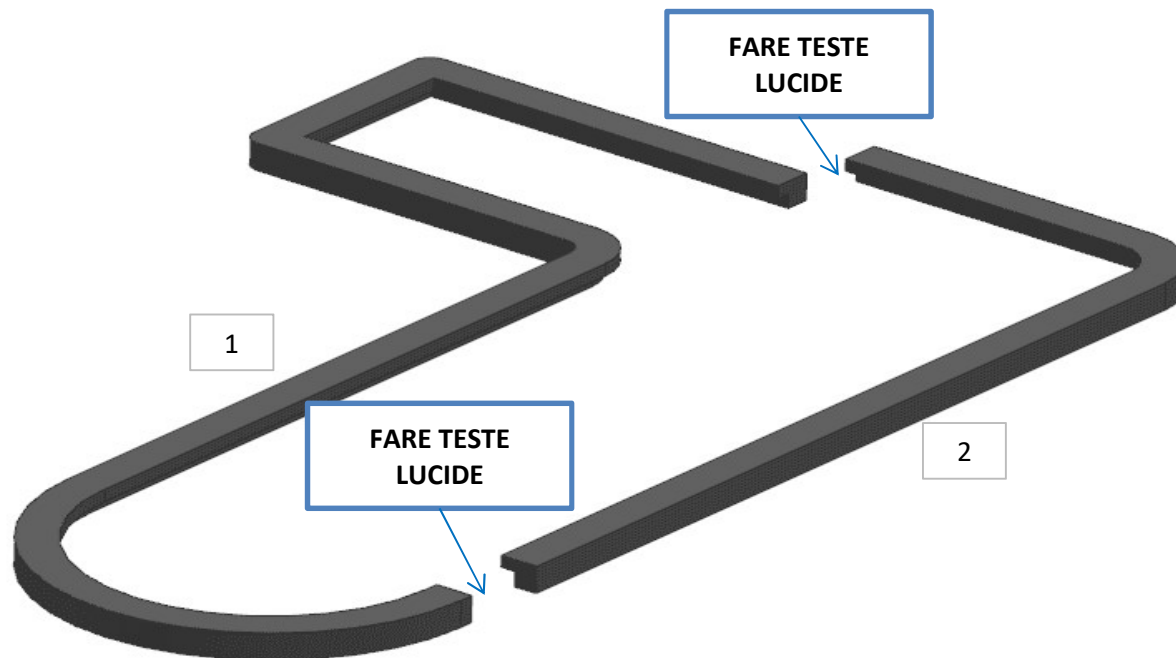

1

2

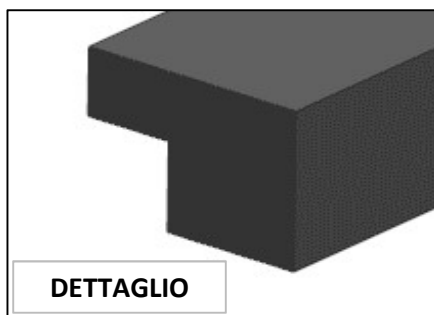

DETTAGLIO

1 - SVILUPPO L. 2553 x H.30 x sp 41  
2 - SVILUPPO L 1360 x H..30 x sp 41

ELEMENTO N. 1 DA MONTARE con:  
**L01\_FB01\_02**  
e spedire con un unico imballo

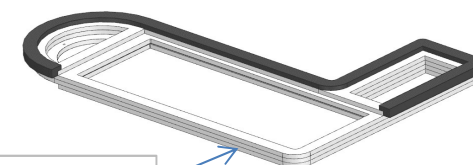

L01\_FB01

ELEMENTO N. 2 DA MONTARE con:  
**L01\_FB01\_01**  
e spedire con un unico imballo

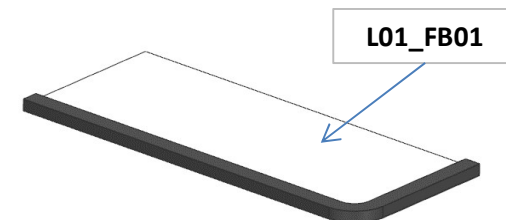

L01\_FB01

consonni&c