

AZ68F

REV. 29-04-2024

LOCALE	CODICE	DESCRIZIONE COMPONENTE	FINITURA	Q.TA	OPERATORE
FRONTE MARCIA	AZ68F-MF_FA01	PARETE DISCESA SCALE			Damiano

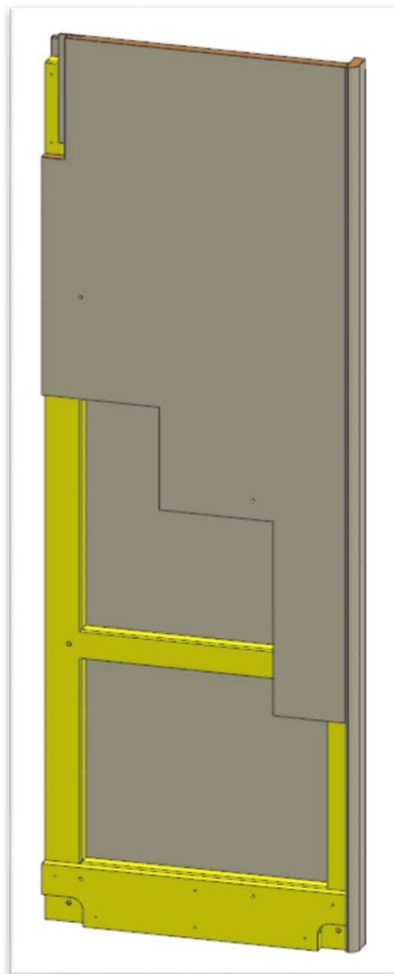

FERRAMENTA:

- N° 5 - FITLOCK MASCHIO
- N° 5 - FITLOCK FEMMINA
- N° 2 - BUSSOLA ZAMA 6MA
- N° 8 - VITI 6MA

AZ68F

REV. 29-04-2024

LOCALE	CODICE	DESCRIZIONE COMPONENTE	FINITURA	Q.TA	OPERATORE
FRONTE MARCIA	AZ68F-FA01	PARETE DISCESA SCALE	OKOUME' GREZZO	1	Damiano

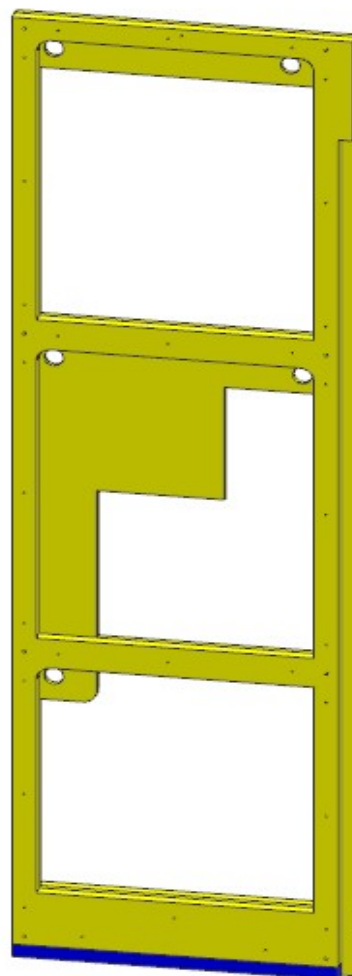

ELEMENTO DA
MONTARE con:
R01_FA01
e spedire con
un unico
imballo

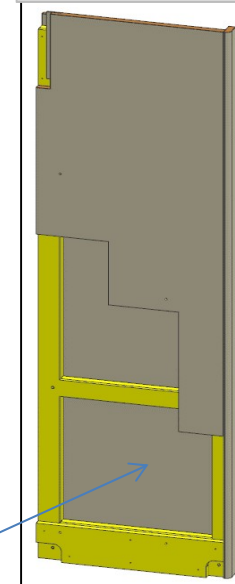

FERRAMENTA:

- N° 5 - FITLOCK MASCHIO
- N° 5 - FITLOCK FEMMINA
- N° 2 - BUSSOLA ZAMA 6MA
- N° 8 - VITI 6MA

R01_FA01

AZ68F

REV. 29-04-2024

LOCALE	CODICE	DESCRIZIONE COMPONENTE	FINITURA	Q.TA	OPERATORE
FRONTE MARCIA	AZ68F-R01_FA01	PARETE DISCESA SCALE	LASTRA CHIARA	4	Damiano

- 1 - L.703 x H 1737 x sp 25
- 2 - L.54 x H 322 x sp 6
- 3 - L.65 x H 2347 x sp 25
- 4 - L.728 x H 2320 x sp 16

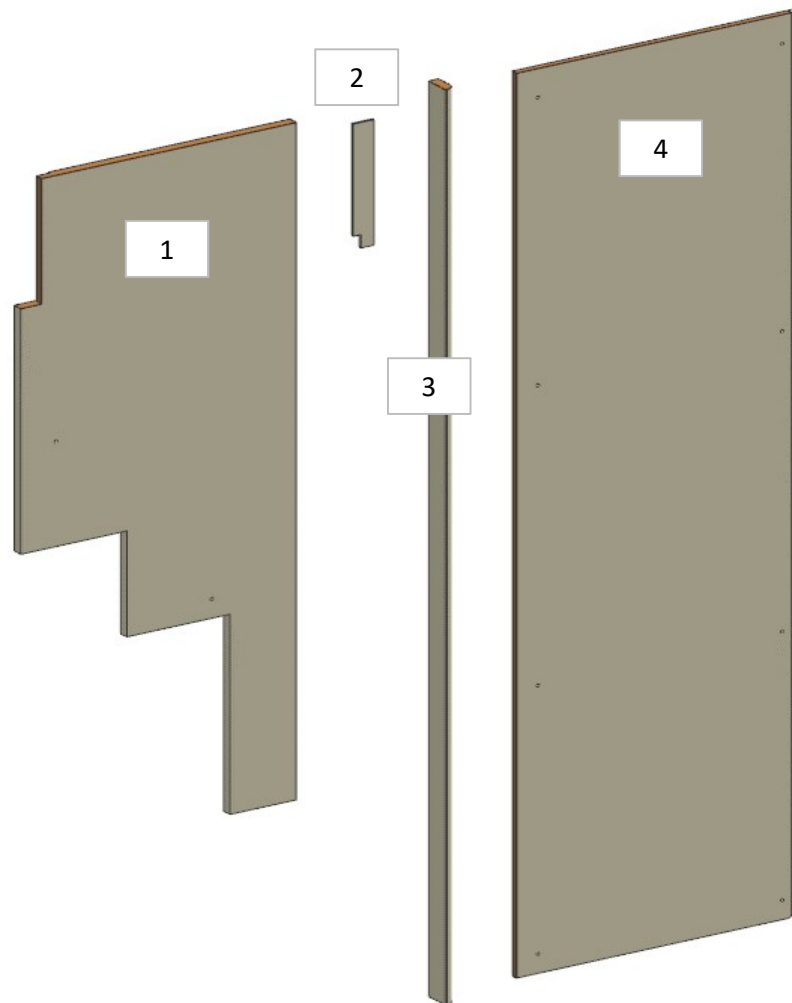

ELEMENTO DA MONTARE
con:
FA01
e spedire con
un unico
imballo

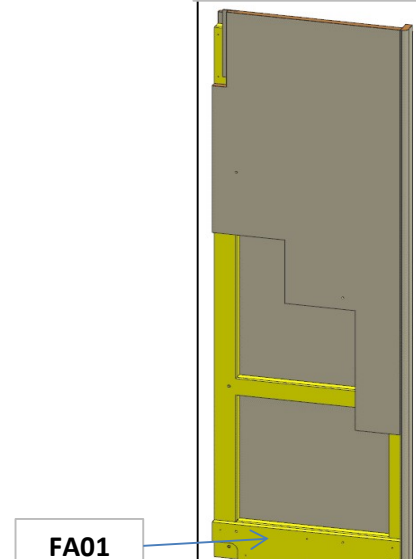

FA01

consonni&c

AZ68F

DA MAT. 237 REV. 18-10-2021

LOCALE	CODICE	DESCRIZIONE COMPONENTE	FINITURA	Q.TA	OPERATORE
FRONTE MARCIA	AZ68F-I01_FB01	MOBILE Q.E. SCALE	OKOUME' GREZZO	6	Damiano

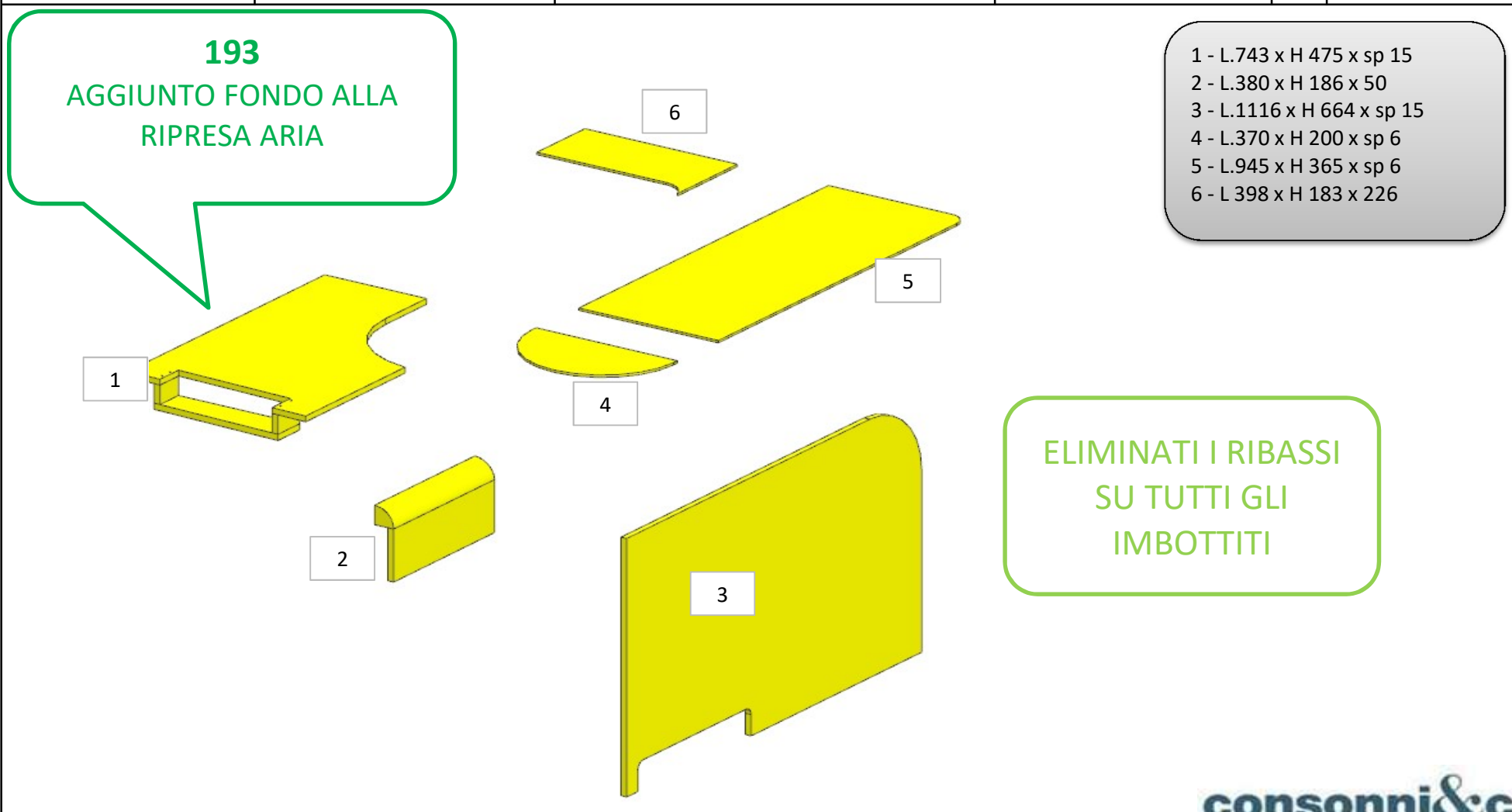

AZ68F

REV. 29-04-2024

LOCALE	CODICE	DESCRIZIONE COMPONENTE	FINITURA	Q.TA	OPERATORE
FRONTE MARCIA	AZ68F-FC01	STRUTTURA SOTTO GUIDA	OKOUME' GREZZO	1	Dante

1 - L.1476 x H.288 x sp 15

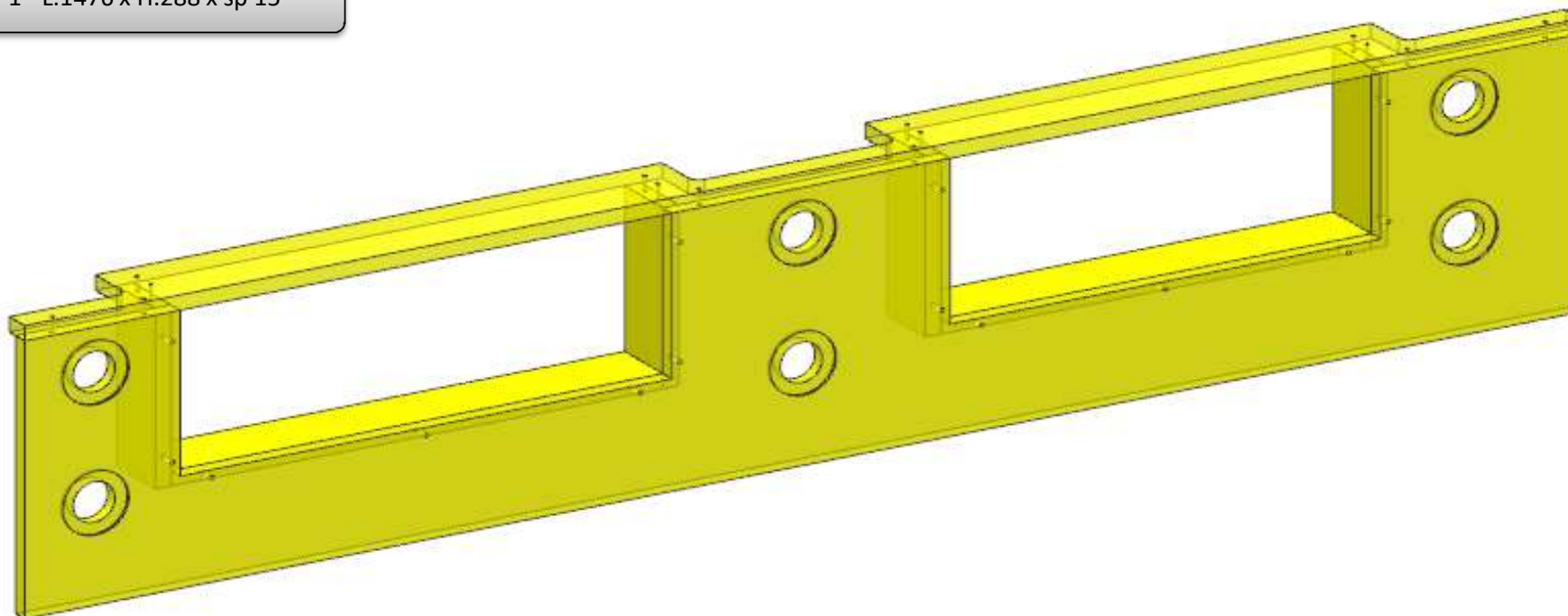

FERRAMENTA:

N° 6 - FITLOCK MASCHIO
N° 6 - FITLOCK FEMMINA

AZ68F

DA MAT.216 REV. 18-10-2021

LOCALE	CODICE	DESCRIZIONE COMPONENTE	FINITURA	Q.TA	OPERATORE
FRONTE MARCIA	AZ68F-I01_FC01	STRUTTURA SOTTO GUIDA	OKOUME' GREZZO	1	Dante

189
AGGIUNTA FINESTRA PER
GRIGLIA

RIDOTTO QUESTO
GRADINO.
VERIFICARE MISURA

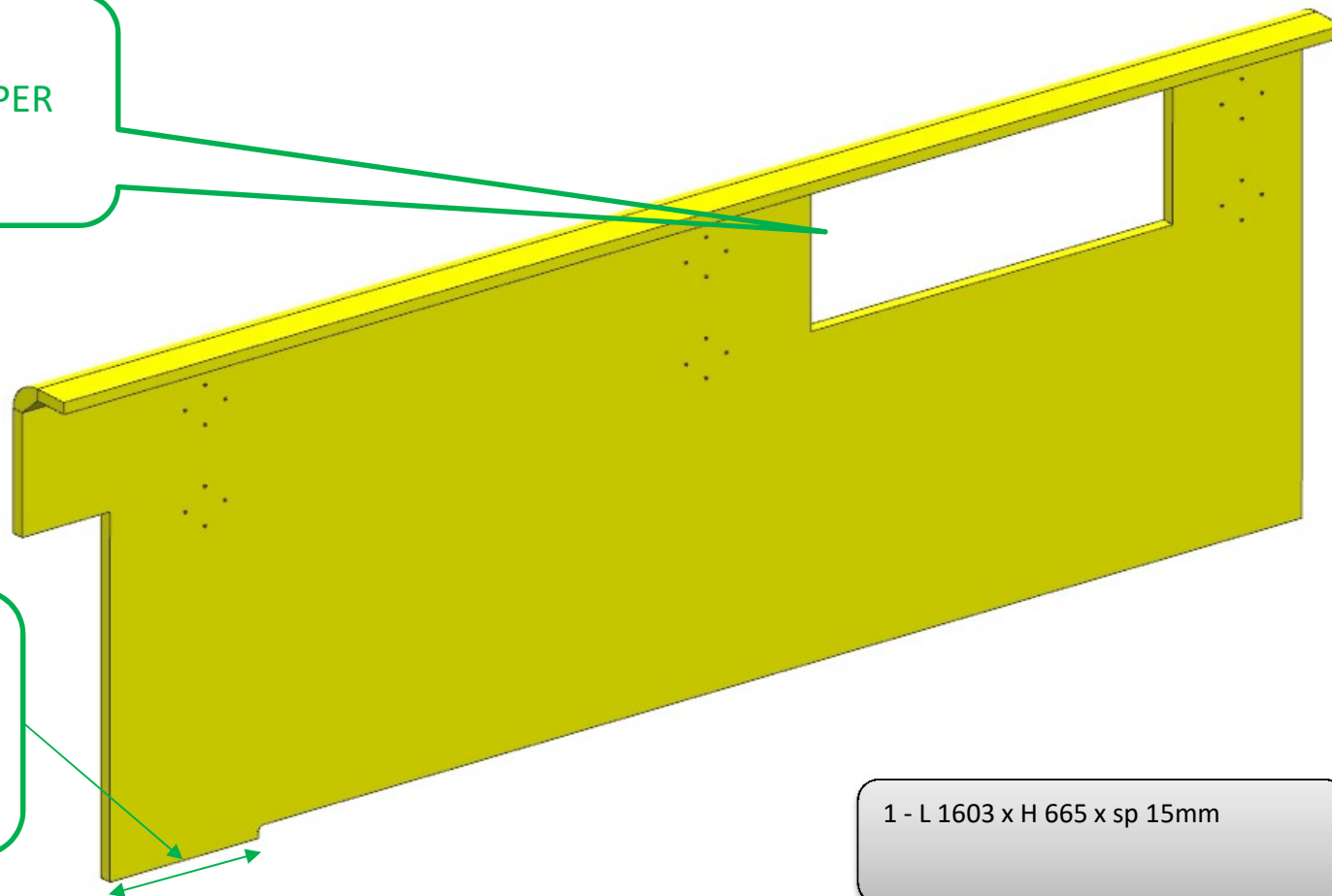

186

1 - L 1603 x H 665 x sp 15mm

AZ68F

DA MAT. 203 REV. 29-04-2024

LOCALE	CODICE	DESCRIZIONE COMPONENTE	FINITURA	Q.TA	OPERATORE
FRONTE MARCIA	AZ68F-R01_FD01	PEDANA GUIDA	LASTRA CHIARA	1	Damiano

1 - L.1304 x H 127. x 30

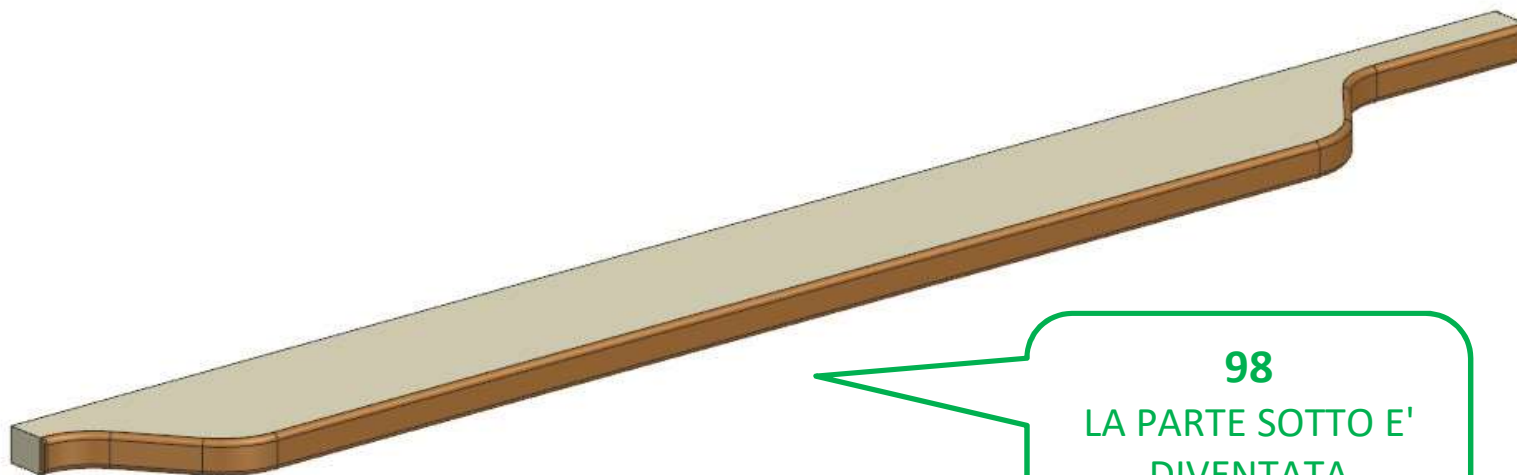

98

LA PARTE SOTTO E'
DIVENTATA
IMBOTTITO

AZ68F

DA MAT. 203 REV. 18-10-2021

LOCALE	CODICE	DESCRIZIONE COMPONENTE	FINITURA	Q.TA	OPERATORE
FRONTE MARCIA	AZ68F-I01_FD01	PEDANA GUIDA	LASTRA CHIARA	1	Damiano

1 - L 1490 x H 180 x 91mm

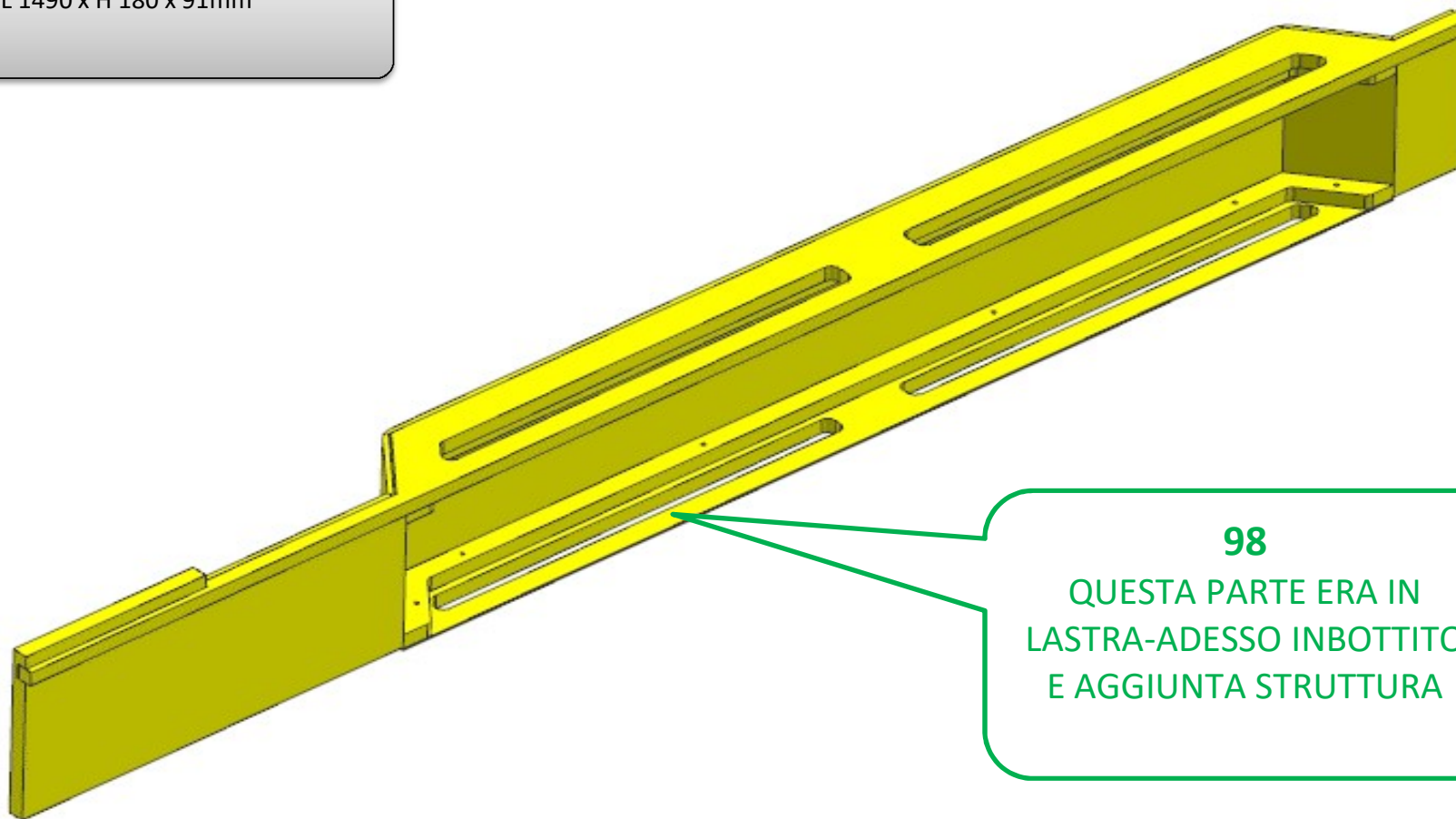

98

QUESTA PARTE ERA IN
LASTRA-ADESSO INBOTTITO
E AGGIUNTA STRUTTURA

AZ68F

DA MAT.

LOCALE	CODICE	DESCRIZIONE COMPONENTE	FINITURA	Q.TA	OPERATORE
FRONTE MARCIA	AZ68F-MG_FE01	CARTER PORTA DX PRUA		5	Damiano

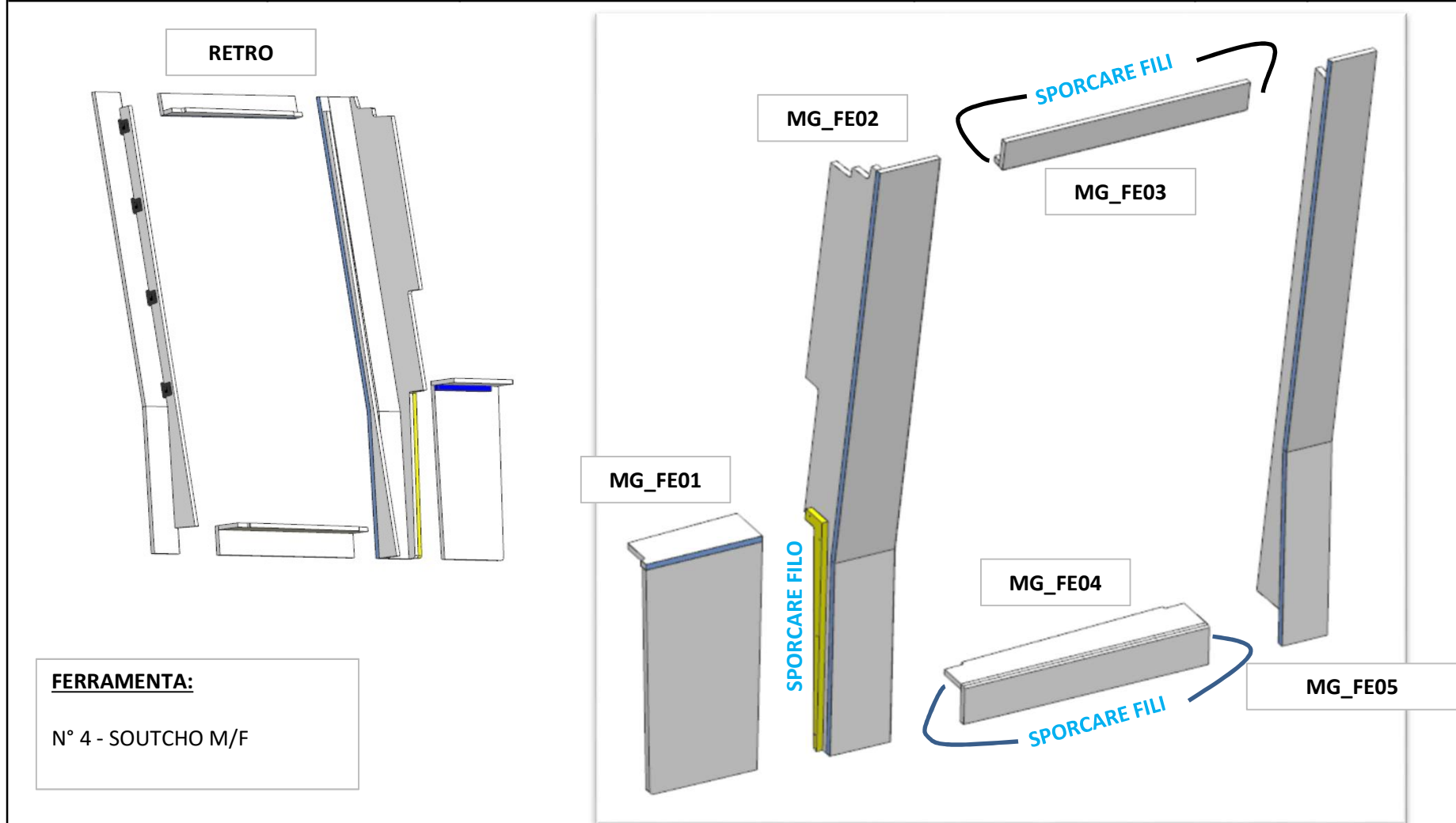

AZ68F

DA MAT. REV. 29-04-2024

LOCALE	CODICE	DESCRIZIONE COMPONENTE	FINITURA	Q.TA	OPERATORE
FRONTE MARCIA	AZ68F-L01_FE01	CARTER PORTA DX PRUA	LACCATO BIANCO ARTICO	12	Damiano

- 1 - L 286 x H 115 x sp 16mm
- 2 - L 286 x H 646 x sp 16mm
- 3 - L 187 x H 1730 x sp 16mm
- 4 - L 149 x H 1196 x sp 16mm
- 5 - L 149 x H 545 x sp 16mm
- 6 - L 601 x H 85 x sp 16 mm
- 7 - L 601 x H 54 x sp 16 mm
- 8 - L 601 x H 106 x sp 16 mm
- 9 - L 601 x H 105 x sp 16 mm
- 10 - L 100 x H 1596 x sp 16mm
- 11 - L 112 x H 1196 x sp 16 mm
- 12 - L 112 x H 545 x sp 16 mm

TUTTI I PEZZI IN LAMINATO DEVONO ESSERE CARTEGGIATI X LA LUCIDATURA (ALMENO LA FACCIA A VISTA)

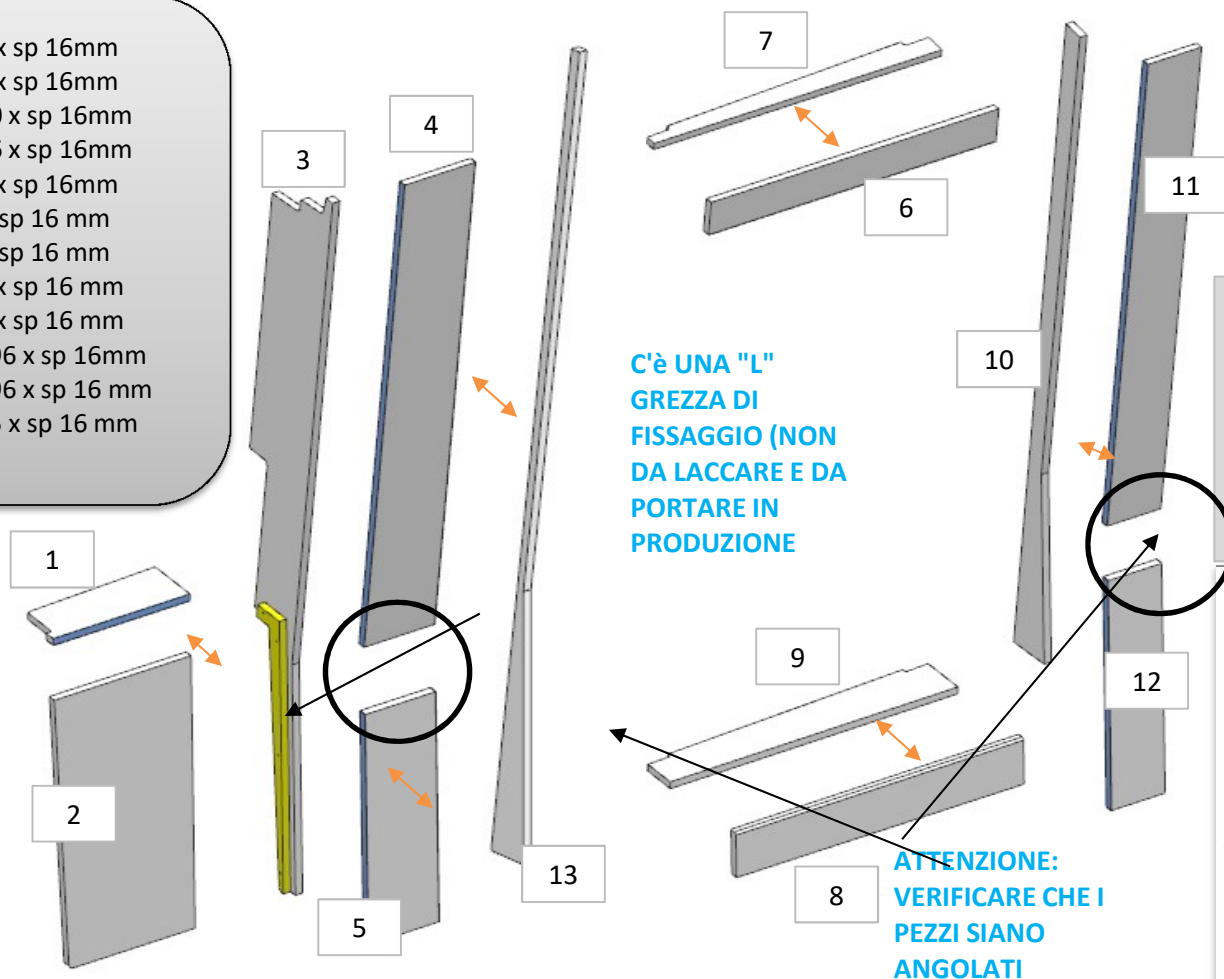

C'è UNA "L" GREZZA DI FISSAGGIO (NON DA LACCARE E DA PORTARE IN PRODUZIONE)

ATTENZIONE: VERIFICARE CHE I PEZZI SIANO ANGOLATI

FERRAMENTA:
N° 4 - SOUTCHO M/F

ELEMENTO DA MONTARE:
MG_FE01/02/03/04/05
e spedire con un unico imballo

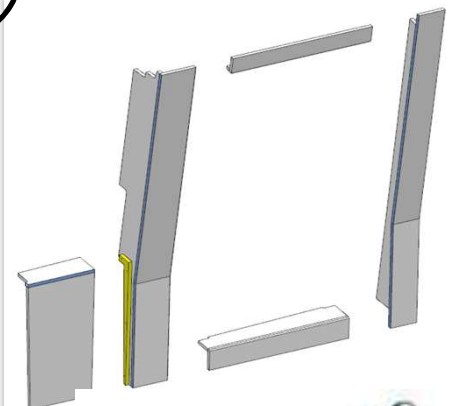

AZ68F

DA MAT. 216 REV. 18-10-2021

LOCALE	CODICE	DESCRIZIONE COMPONENTE	FINITURA	Q.TA	OPERATORE
FRONTE MARCIA	AZ68F-I01_FG01	PANNELLI ANTIRIFLESSO	OKOUME' GREZZO	3	Dante

- 1 - L 1622 x H 845 x sp 15mm
- 2 - L 1584 x H 751 x sp 15mm
- 3 - L 2195 x sp 15mm

189
AGGIUNTA FINESTRA PER
GRIGLIA

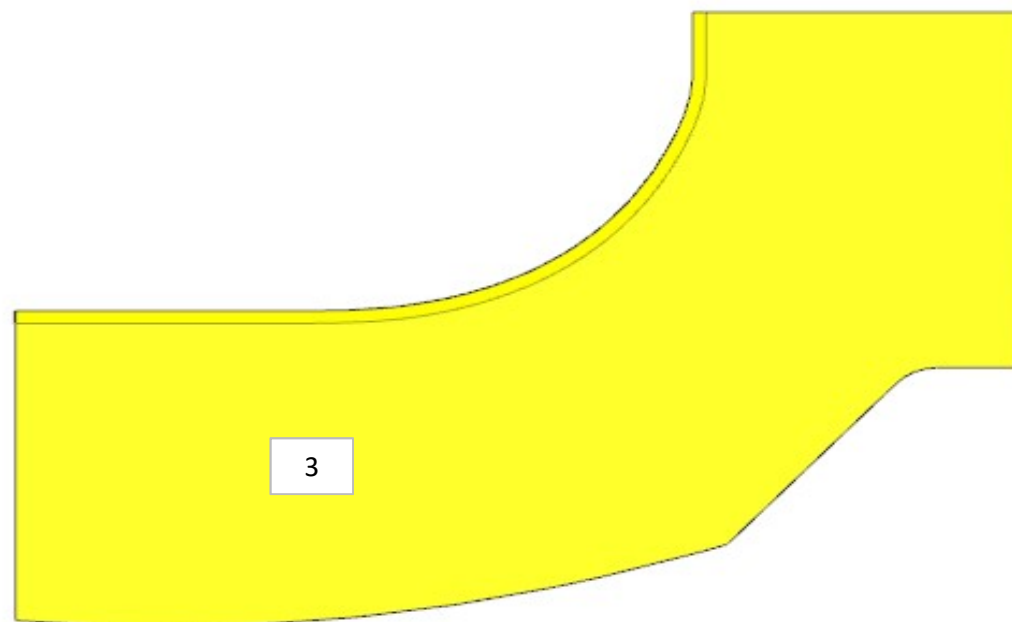
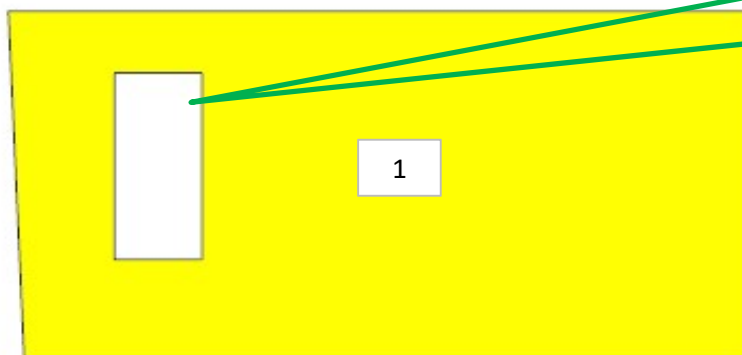

AZ68F

Prototipo 02-2021

LOCALE	CODICE	DESCRIZIONE COMPONENTE	FINITURA	Q.TA	OPERATORE
FRONTE MARCIA	AZ68F-A01_FH01	ACCIAIO SCALA	ACCIAIO	1	Damiano

1 - L.1049 x H 857 x 40 x sp 5

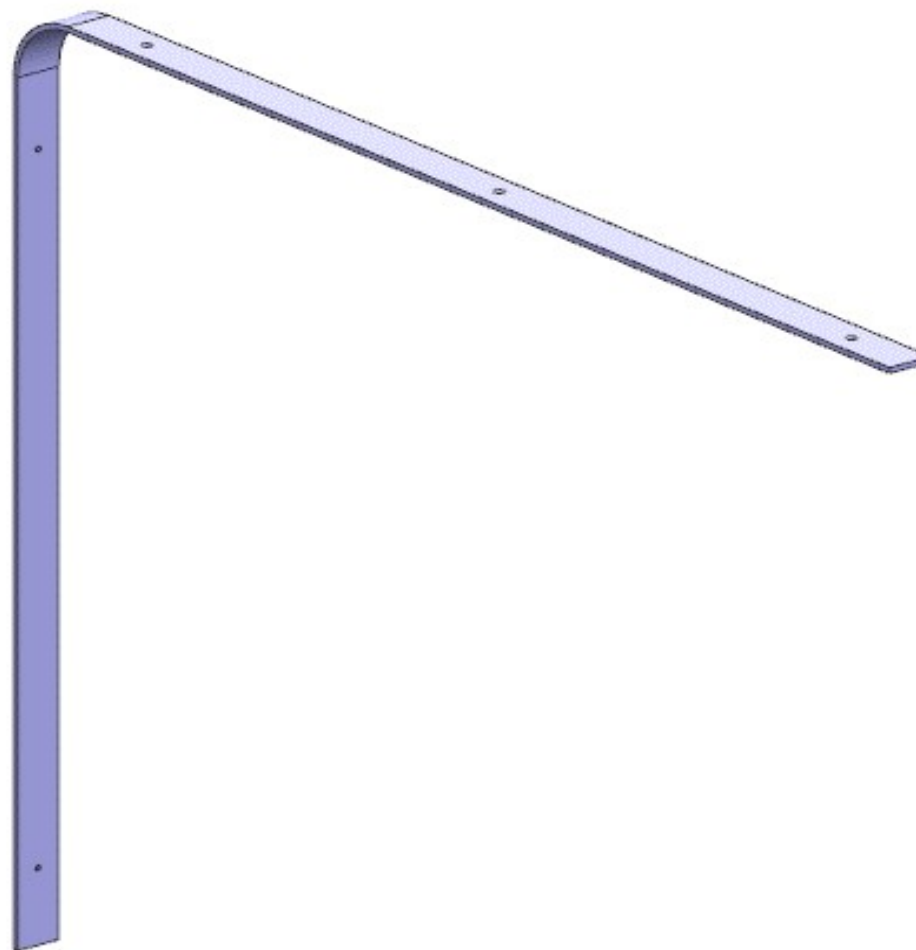

AZ68F

REV. 18-10-2021

LOCALE	CODICE	DESCRIZIONE COMPONENTE	FINITURA	Q.TA	OPERATORE
FRONTE MARCIA	AZ68F-I01_FL01	PANNELLO IMBOTTITO SX GUIDA	OKOUME' GREZZO	1	Dante

1 - L.189 x H 861 x sp 20

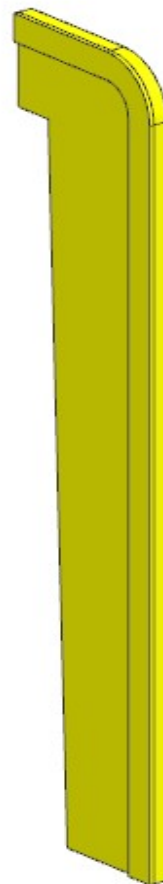

AZ68F

DA MAT. 216 REV. 29-04-2024

LOCALE	CODICE	DESCRIZIONE COMPONENTE	FINITURA	Q.TA	OPERATORE
FRONTE MARCIA	AZ68F-L01_FM01	GRIGLIE TRATTAMENTO ARIA-STD	LACCATO BRONZO	2	Damiano

1/2 - L 450 x H 189 x sp 16

190
MODIFICATE MISURE

FERRAMENTA:

N° 4 - KEKU M/F

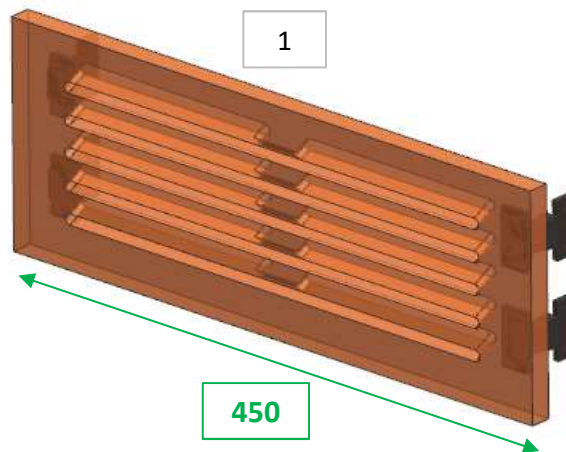

AGGIUNTO CODICE

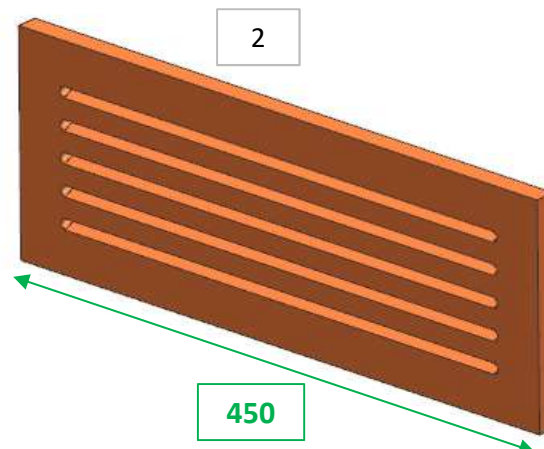

AZ68F

REV. 18-10-2021

LOCALE	CODICE	DESCRIZIONE COMPONENTE	FINITURA	Q.TA	OPERATORE
FRONTE MARCIA	AZ66F-I01_FN01	TAMP. SOPRA PARAPREZZA	OKOUME' GREZZO	3	Dante

- 1 - L. 1653
- 2 - L. 2060
- 3 - L. 2464

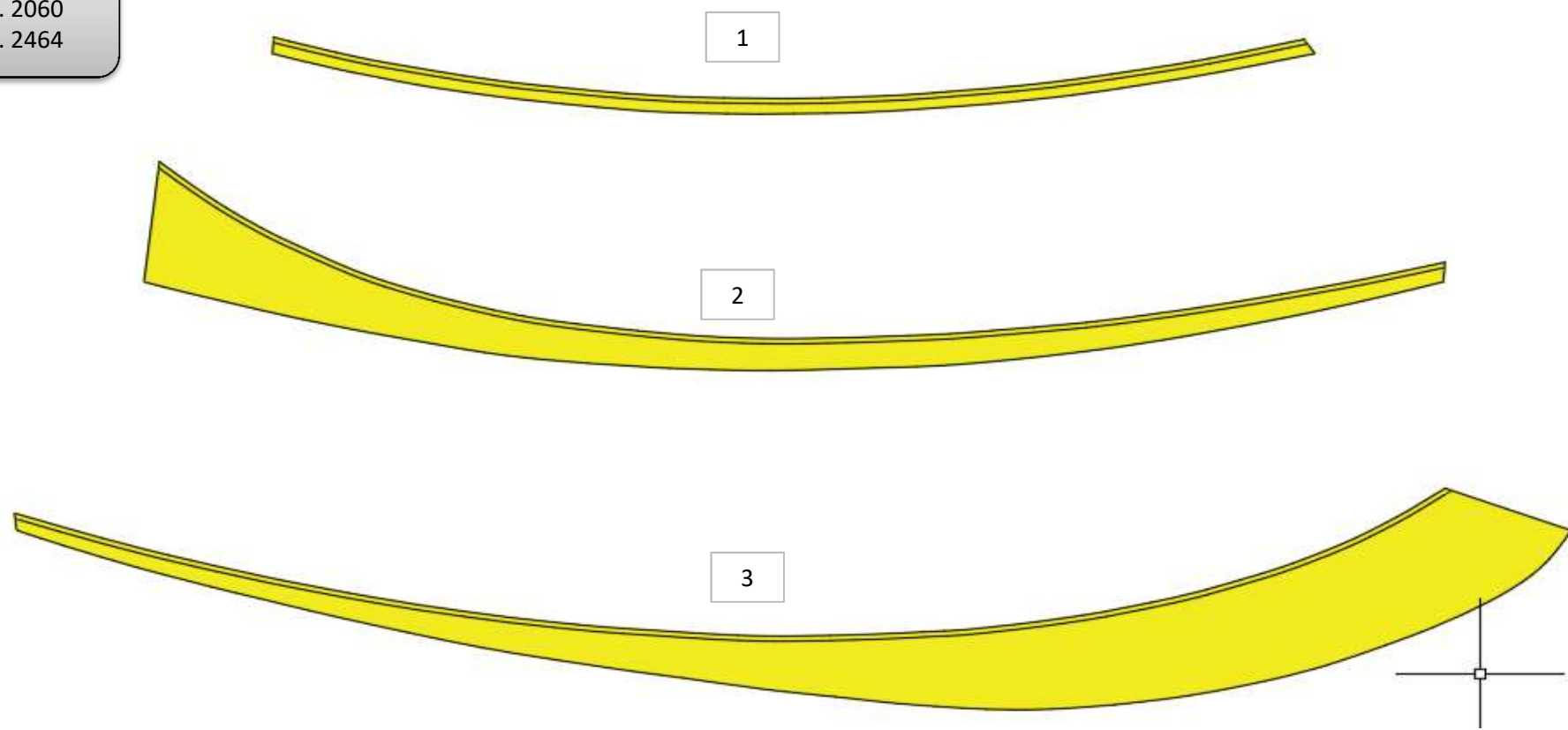

AZ68F

DA MAT. 216 REV. 29-04-2024

LOCALE	CODICE	DESCRIZIONE COMPONENTE	FINITURA	Q.TA	OPERATORE
FRONTE MARCIA	AZ68F-FO01	PLENUM	GREZZO VERNICIATO ANTI ROMBO	1	Dante

1 - L 259 x H 111mm

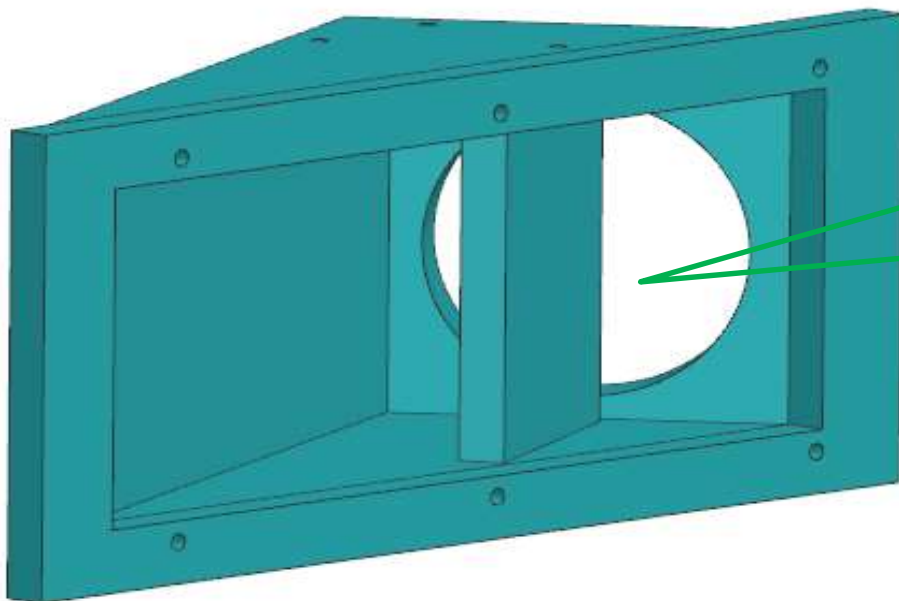

**CODICE AGGIUNTO DA GR.5
VERNICIARE INTERNO ED
ESTERNO CON VERNICE
ANTI-ROMBO**

AZ68F

DA MAT. 211 REV. 29-04-2024

LOCALE	CODICE	DESCRIZIONE COMPONENTE	FINITURA	Q.TA	OPERATORE
FRONTE MARCIA	AZ68F-FP01	UNITA' TRATTAMENTO ARIA OPT	OKOUME' VERNICIATO NERO	1	Dante

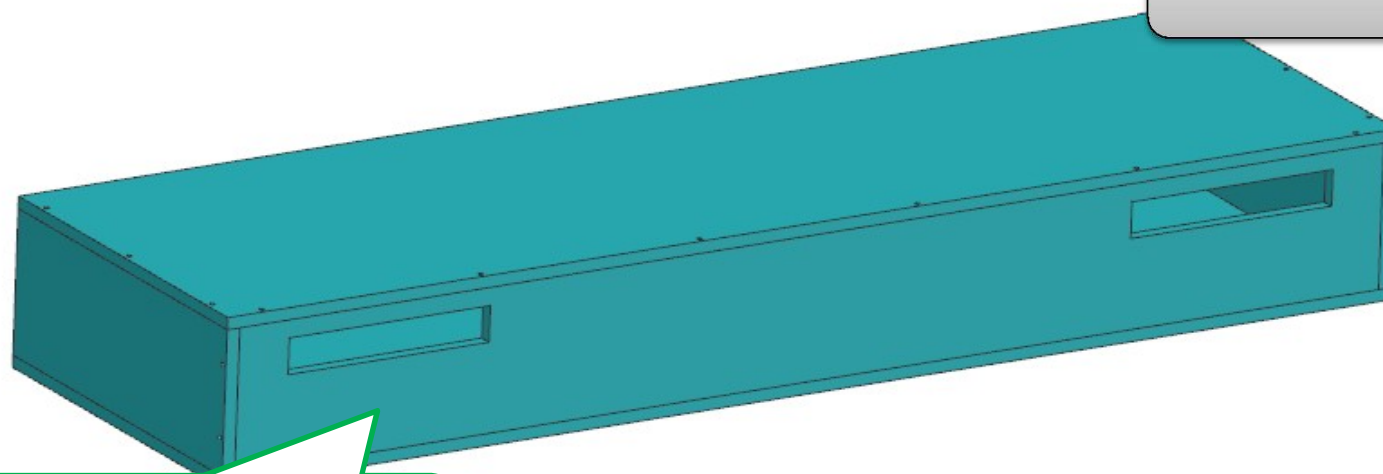

1 - L.931 x H.140 x pr.287mm

CODICE AGGIUNTO DA GR.4
VERNICIARE INTERNO ED
ESTERNO NERO OPACO