

AZ68F

REV. 29-04-2024

LOCALE	CODICE	DESCRIZIONE COMPONENTE	FINITURA	Q.TA	OPERATORE
CABINA OSPITI SX	AZ68F-MG_LA01	LETTO MURATA			Damiano

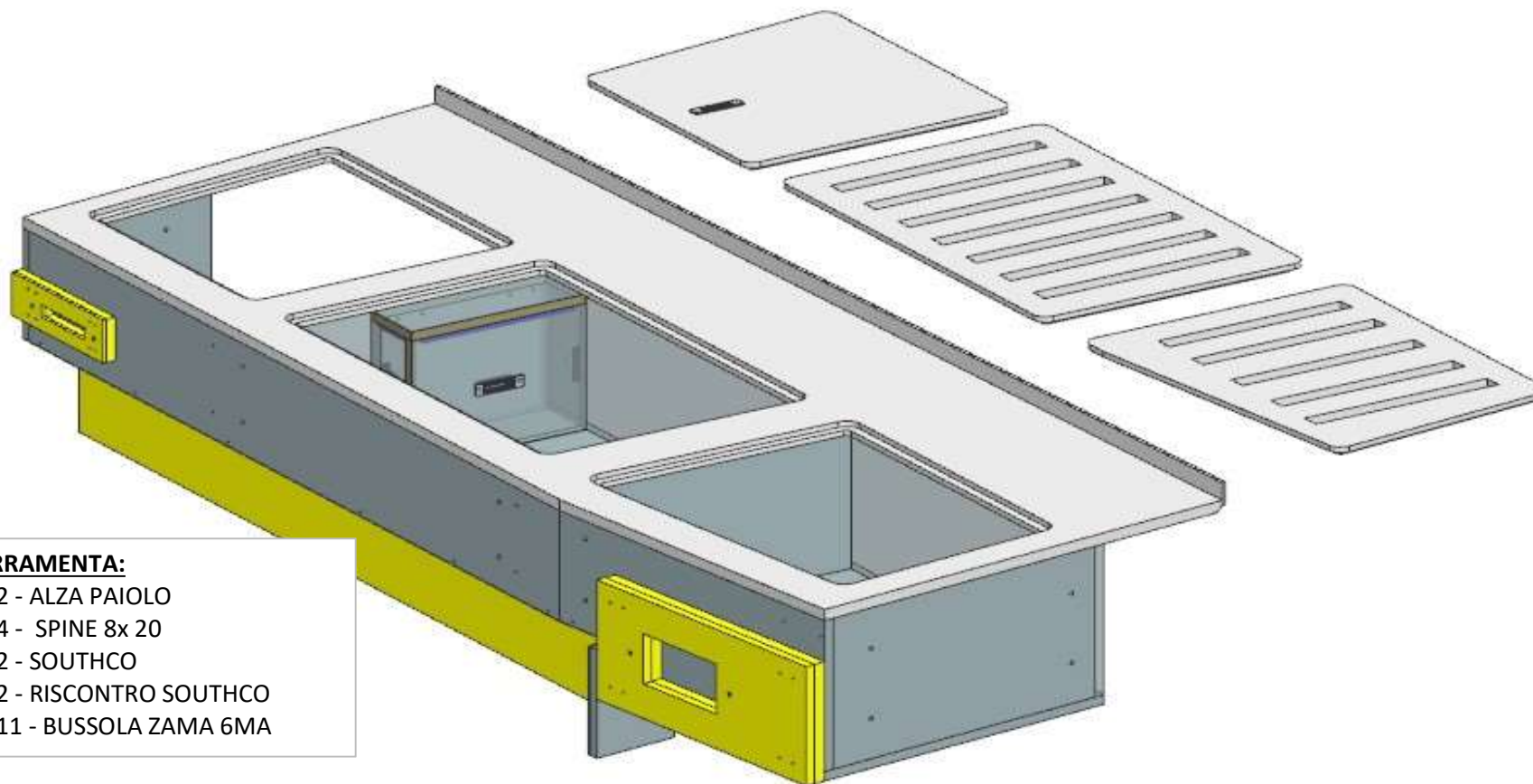

FERRAMENTA:

- N° 2 - ALZA PAIOLO
- N° 4 - SPINE 8x 20
- N° 2 - SOUTHCO
- N° 2 - RISCONTRO SOUTHCO
- N° 11 - BUSSOLA ZAMA 6MA

AZ68F

DA MAT.233

REV. 29-04-2024

LOCALE	CODICE	DESCRIZIONE COMPONENTE	FINITURA	Q.TA	OPERATORE
CABINA OSPITI SX	AZ68F-LA01	LETTO MURATA	LAMINATO NADIR \ GOFFRATONE	5	Damiano

- 2 - L.2030 x H.766 x sp 19
- 3 - L.453 x H.443 x sp 19
- 4 - L.453 x H.700 x sp 19
- 5 - L.453 x H.544 x sp 19

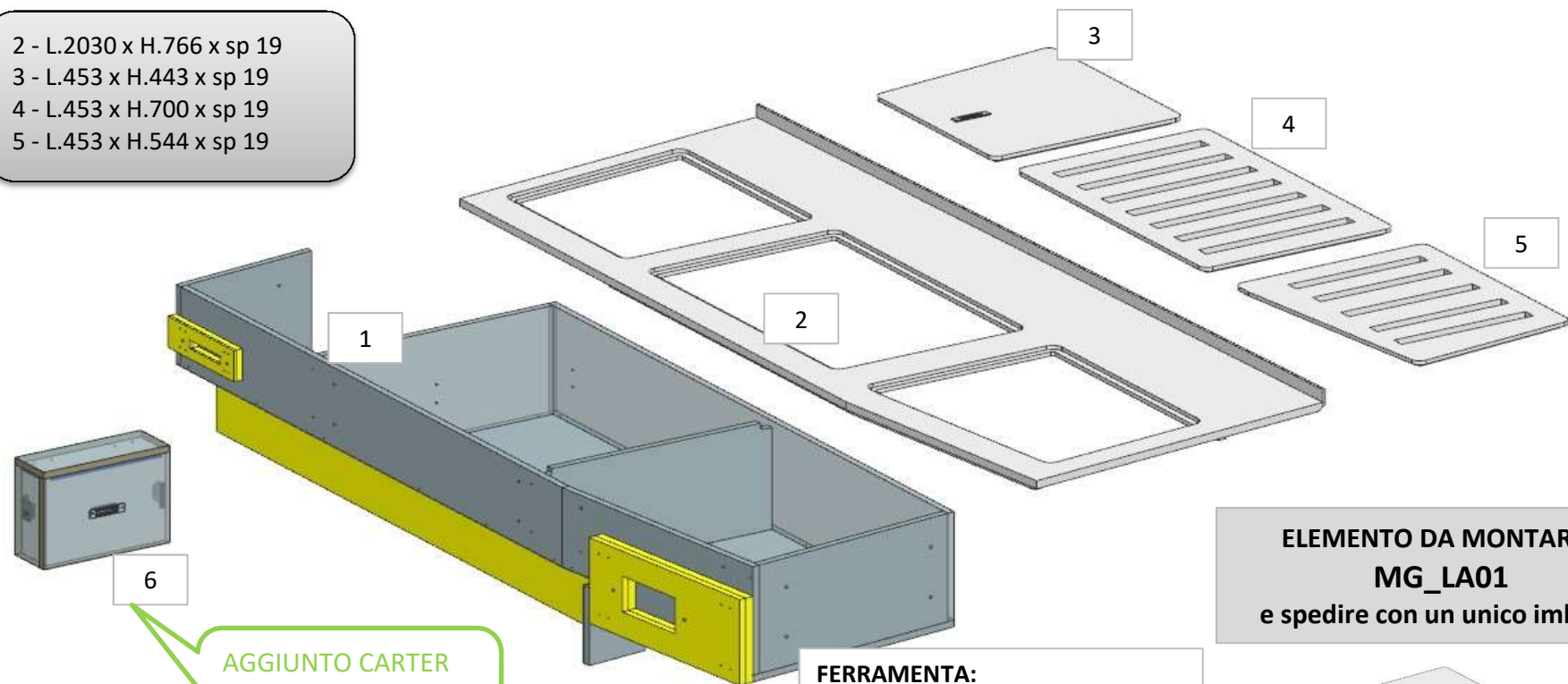

AGGIUNTO CARTER
DIPER COPERTURA
CENTRALINA

- FERRAMENTA:**
- N° 2 - ALZA PAIOLO
 - N° 4 - SPINE 8x 20
 - N° 2 - SOUTHCO
 - N° 2 - RISCOSTRO SOUTHCO
 - N° 11 - BUSSOLA ZAMA 6MA

ELEMENTO DA MONTARE :
MG_LA01
e spedire con un unico imballo

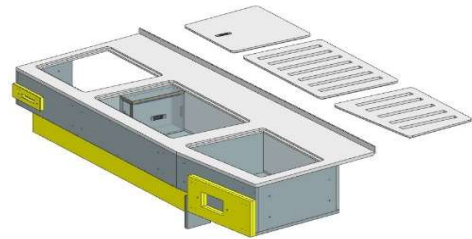

AZ68F

REV. 10-01-2022

LOCALE	CODICE	DESCRIZIONE COMPONENTE	FINITURA	Q.TA	OPERATORE
CABINA OSPITI SX	AZ68F-MF_LE01	COMODINO			Damiano

FERRAMENTA:

N° 1 - MANIGLIA FORESTE E SUARDI
CP 1 - GUIDE CASSETTO da 250
N° 5 - VITI 6MA
N° 5 - BUSSOLE ZAMA 6MA

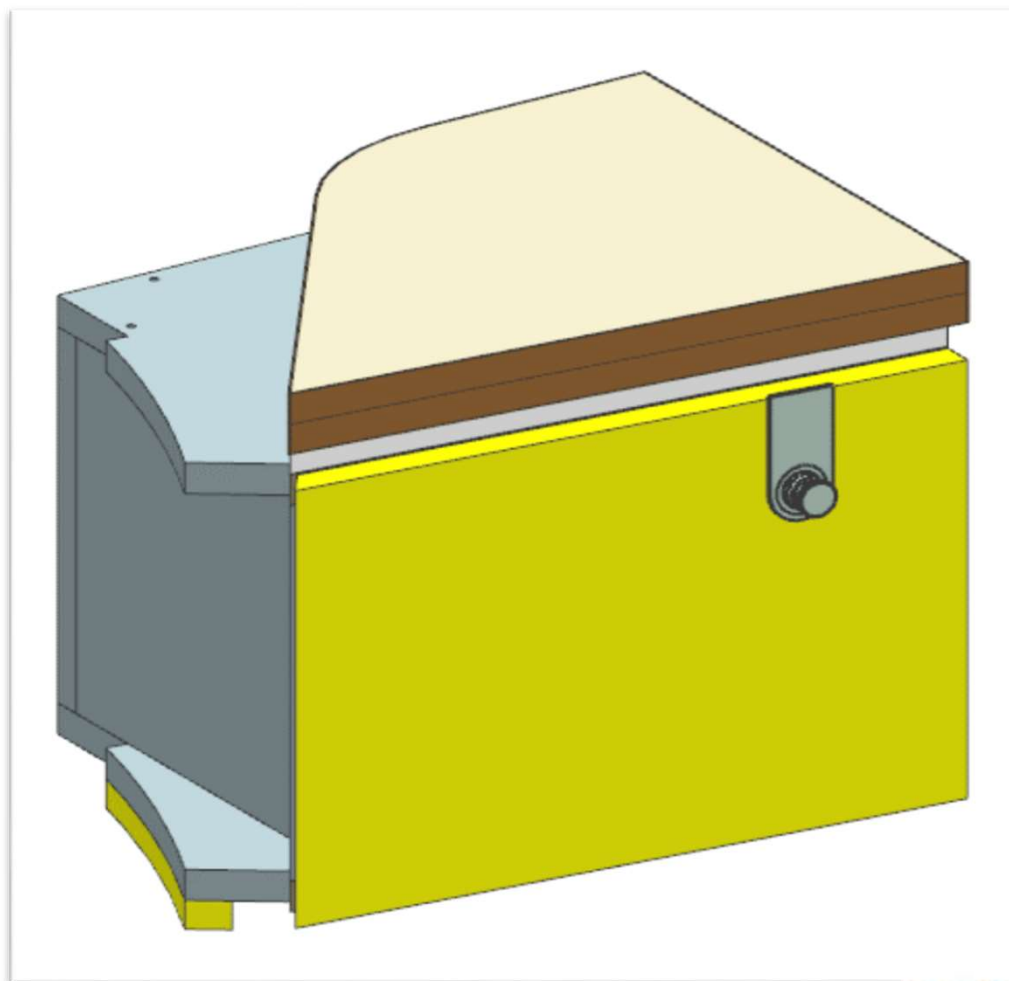

consonni&c

AZ68F

REV. 29-04-2024

LOCALE	CODICE	DESCRIZIONE COMPONENTE	FINITURA	Q.TA	OPERATORE
CABINA OSPITI SX	AZ68F-LE01	COMODINO	LAMINATO NADIR	1	Damiano

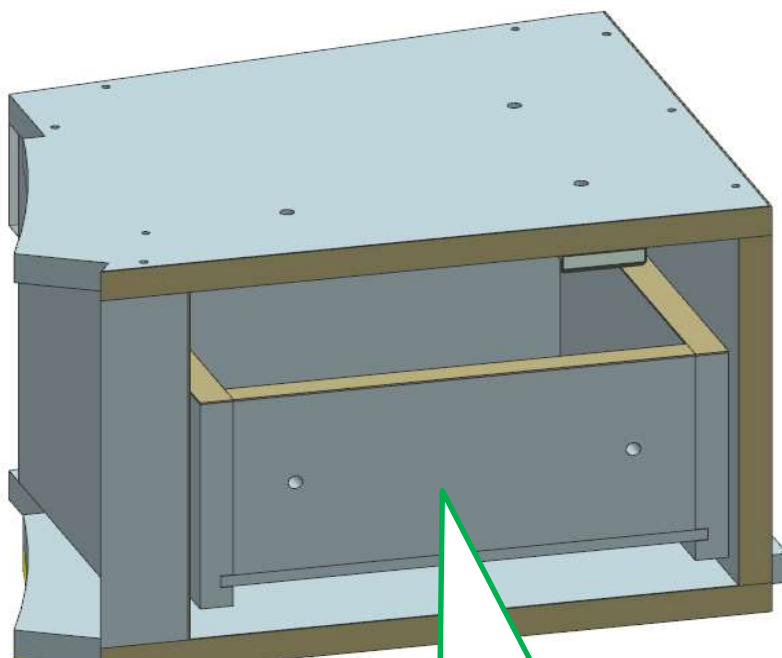

FERRAMENTA:

N° 1 - MANIGLIA FORESTE E SUARDI
CP 1 - GUIDE CASSETTO da 250
N° 5 - VITI 6MA
N° 5 - BUSSOLE ZAMA 6MA

44
MODIFICATO
CASSETTO INTERNO

ELEMENTO DA MONTARE con:

R01_LE01

L01_LE01

I01_LE01

X01_LE01

e spedire con un unico imballo

R01_LE01

L01_LE01

X01_LE01

I01_LE01

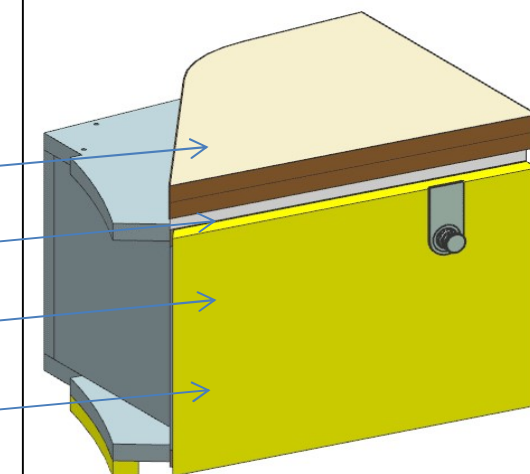

consonni&c

AZ68F

REV. 10-01-2022

LOCALE	CODICE	DESCRIZIONE COMPONENTE	FINITURA	Q.TA	OPERATORE
CABINA OSPITI SX	AZ68F-R01_LE01	COMODINO	LASTRA CHIARA	1	Damiano

1 - L.336 x H.278 x sp 31

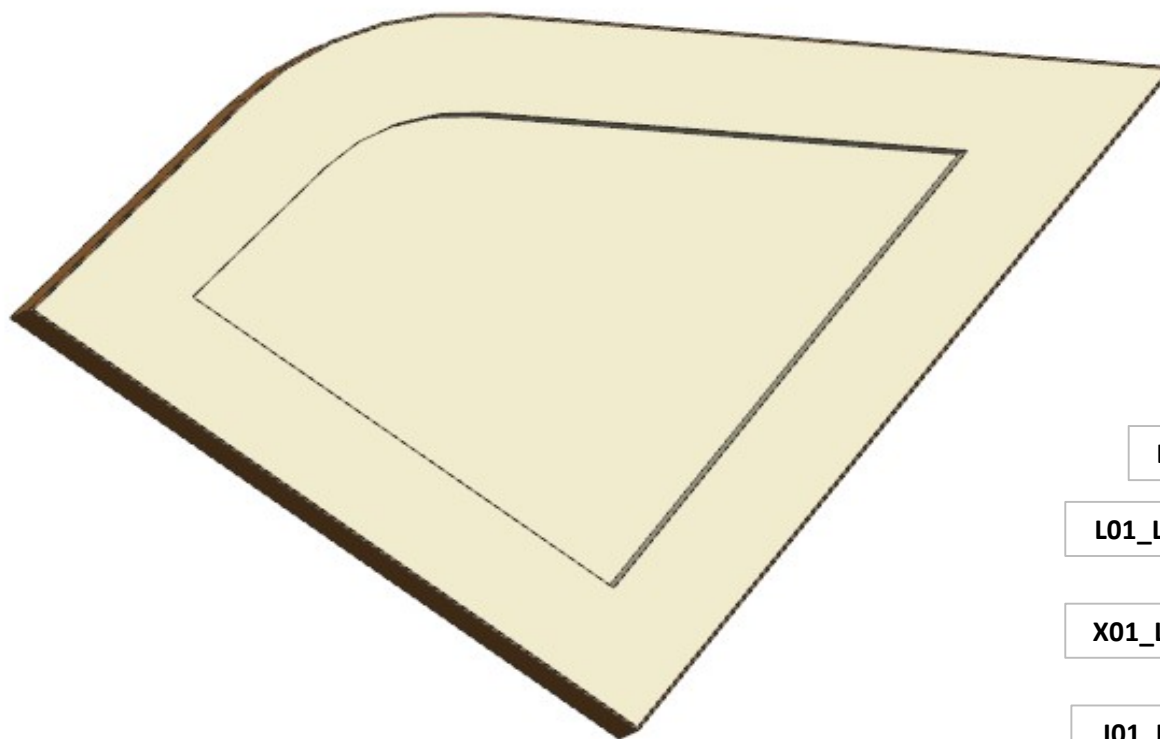

ELEMENTO DA MONTARE con:
LE01
L01_LE01
I01_LE01
X01_LE01
e spedire con un unico imballo

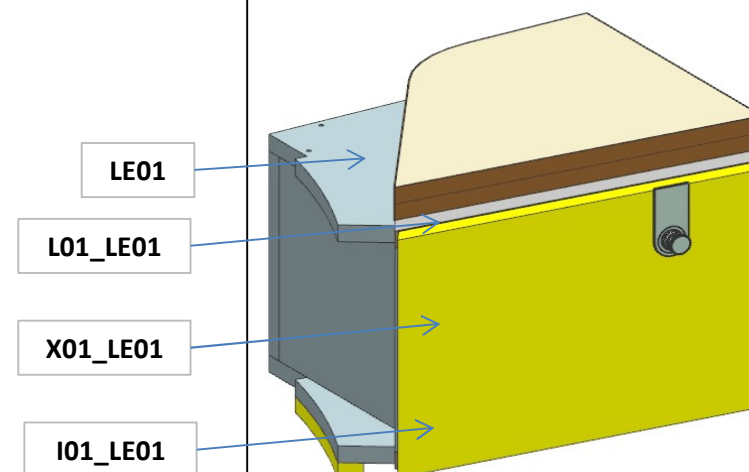

consonni&c

AZ68F

REV. 15-11-2022

LOCALE	CODICE	DESCRIZIONE COMPONENTE	FINITURA	Q.TA	OPERATORE
CABINA OSPITI SX	AZ68F-L01_LE01	COMODINO	LACCATO BIANCO ARTICO	1	Damiano

1 - L.324 x H 259 x sp 19

LATO SOTTO

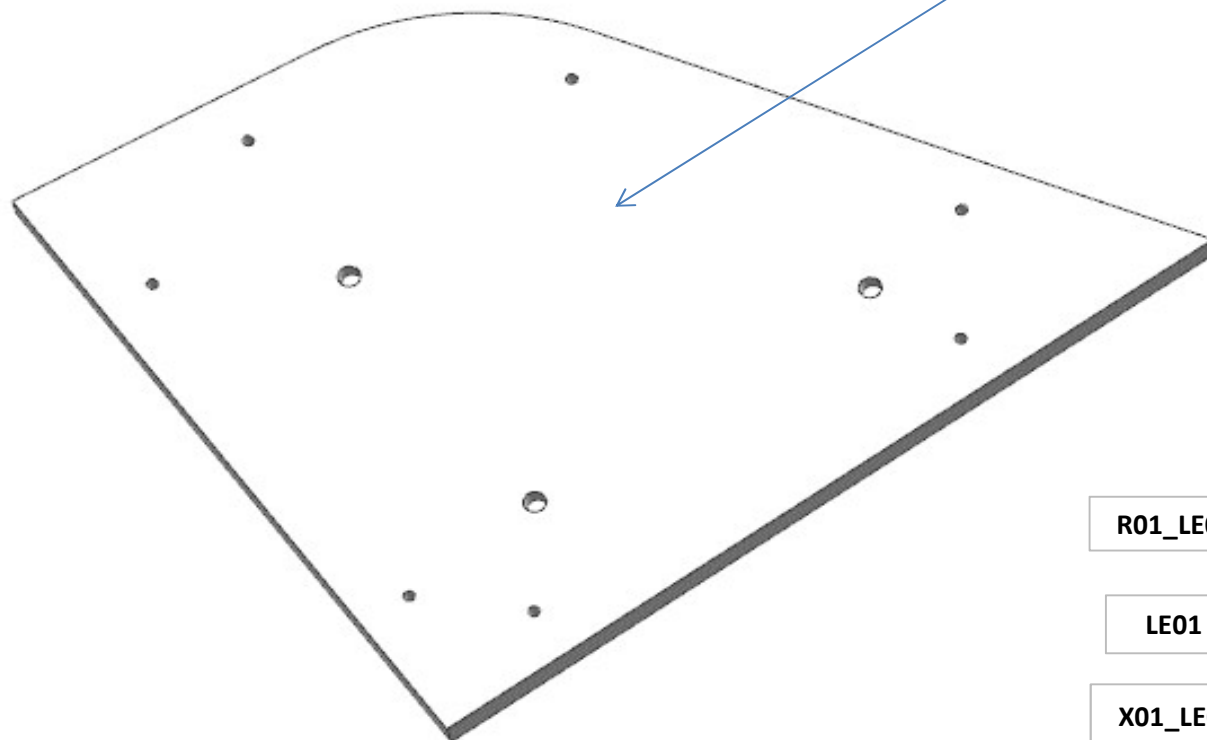

ELEMENTO DA MONTARE con:
R01_LE01
X01_LE01
LE01
I01_LE01
e spedire con un unico imballo

R01_LE01

LE01

X01_LE01

I01_LE01

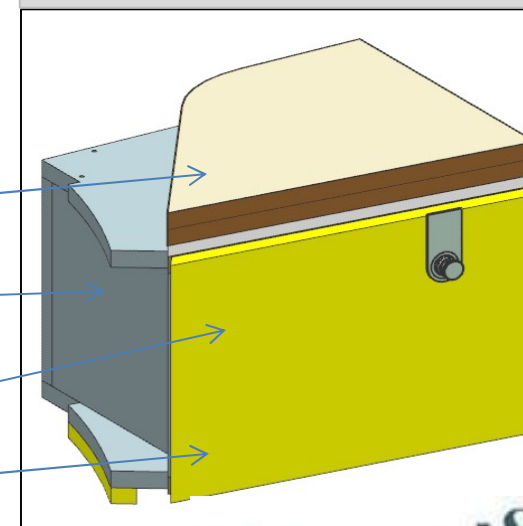

consonni&c

AZ68F

DA MAT.201 REV. 10-01-2022

LOCALE	CODICE	DESCRIZIONE COMPONENTE	FINITURA	Q.TA	OPERATORE
CABINA OSPITI SX	AZ68F-I01_LE01	COMODINO	OKOUME' GREZZO	2	Damiano

163

DIVISO IN 2 PEZZI PER
FACILITARE



ELEMENTO DA MONTARE con:

R01_LE01

L01_LE01

X01_LE01

LE01

e spedire con un unico imballo

1 - L.332 x H 225 x sp 15mm
2 - L.284 x H 188 x sp 6mm

R01_LE01

L01_LE01

X01_LE01

LE01

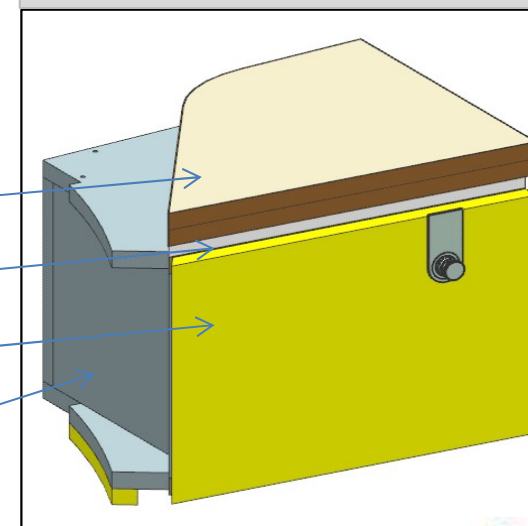

consonni&c

AZ68F

DA MAT.201

REV. 26-10-2022

LOCALE	CODICE	DESCRIZIONE COMPONENTE	FINITURA	Q.TA	OPERATORE
CABINA OSPITI SX	AZ68F-X01_LE01	COMODINO	LAMINATO	1	Damiano

163

AGGIUNTO PER
FACILITARE

LAMINATO DI
QUALSIASI TIPO -
NON A VISTA

ELEMENTO DA MONTARE con:

R01_LE01

L01_LE01

I01_LE01

LE01

e spedire con un unico imballo

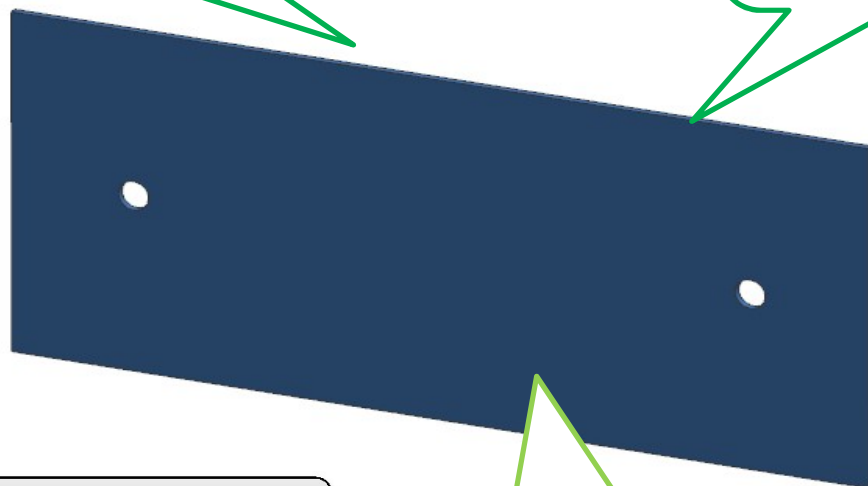

1 - L 227 x H. 95 x sp 2

PEZZO DA CODIFICARE E DA
INCOLLARE ALLA PARTE
GREZZA

R01_LE01

L01_LE01

I01_LE01

LE01

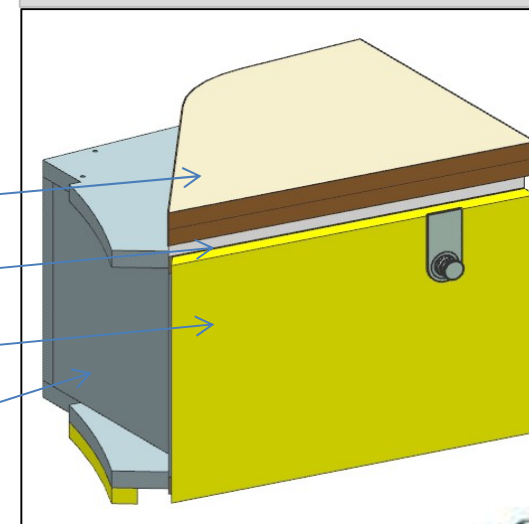

consonni&c