

# AZ26M

REV. GR 9

LOCALE	CODICE	DESCRIZIONE COMPONENTE	FINITURA	Q.TA	OPERATORE
SALONE	AZ26M-SA01	STRUTTURA MURATA DX PRUA	OKOUME' GREZZO	2	Damiano

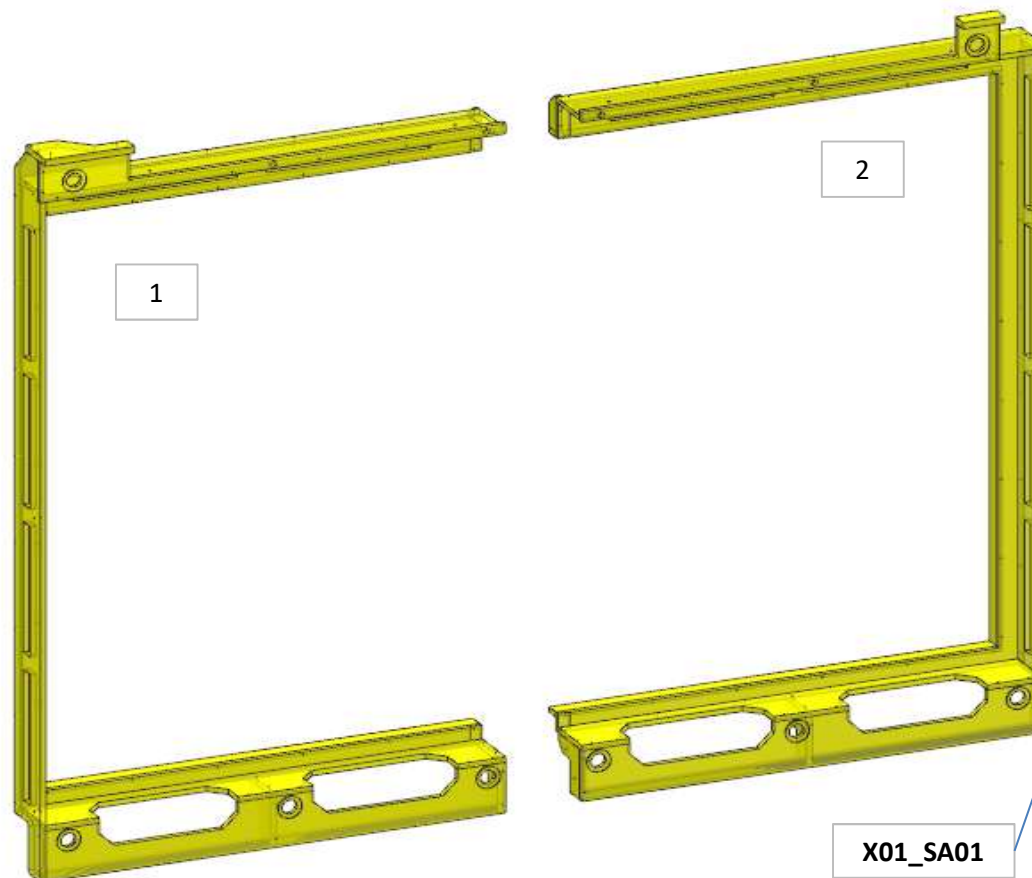

**ELEMENTO DA MONTARE con:  
X01\_SA01  
e spedire con un  
unico imballo**

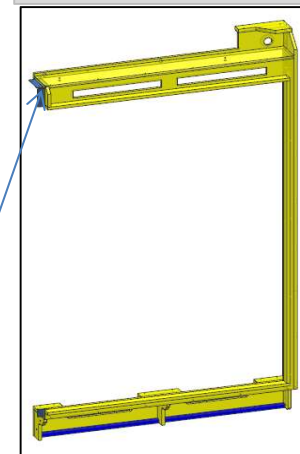

**FERRAMENTA:**

- N° 8 - FITLOCK MASCHIO
- N° 8 - FITLOCK FEMMINA
- N° 4 - FAST MOUNT FEMMINA
- N° 4 - FAST MOUNT MASCHIO
- N° 28 - SPINA diam 8
- N° 5 - BUSSOLA ZAMA 6MA
- N° 9 - VITI 6MA

# AZ26M

REV. 01-2023

REV. GR 9

LOCALE	CODICE	DESCRIZIONE COMPONENTE	FINITURA	Q.TA	OPERATORE
SALONE	AZ26M-SB01	PLENUM MURATA DX PRUA	GREZZO VERNICIATO ANTI ROMBO	1	Damiano

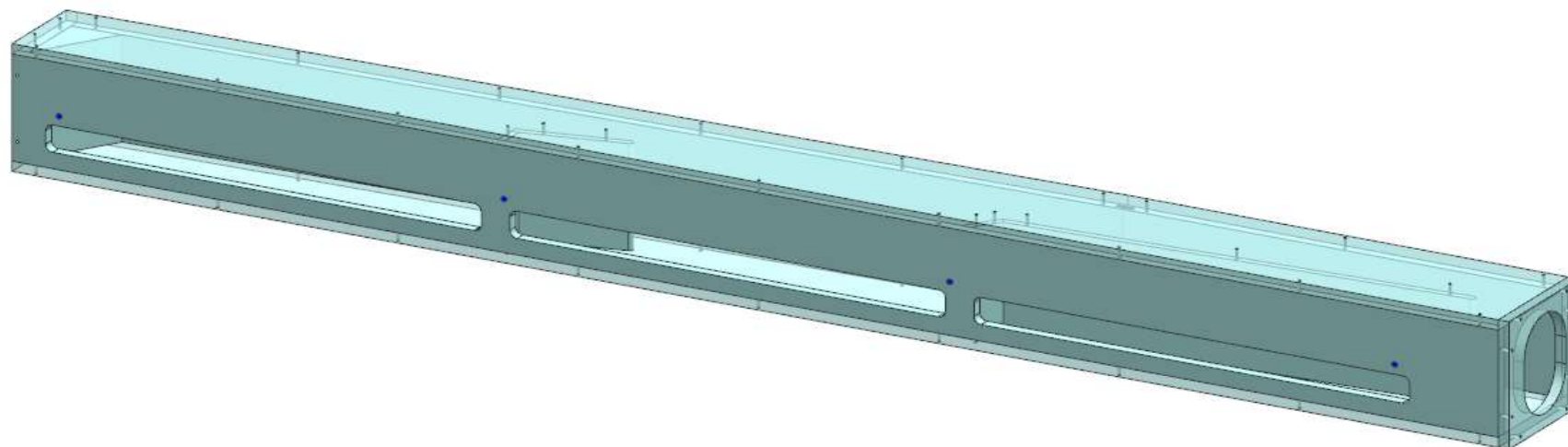

**FERRAMENTA:**

- N° 11 - SPINA diam 8
- N° 8 - BUSSOLA ZAMA 6MA
- N° 4 - VITI 6MA

# AZ26M

REV. GR 9

LOCALE	CODICE	DESCRIZIONE COMPONENTE	FINITURA	Q.TA	OPERATORE
SALONE	AZ26M-SC01	STRUTTURA MONTANTE DX	OKOUME' GREZZO	1	Damiano



**FERRAMENTA:**

- N° 8 - FITLOCK MASCHIO
- N° 8 - FITLOCK FEMMINA
- N° 4 - BUSSOLA ZAMA 6MA
- N° 6 - VITI 6MA

# AZ26M

REV. GR 9

LOCALE	CODICE	DESCRIZIONE COMPONENTE	FINITURA	Q.TA	OPERATORE
SALONE	AZ26M-SD01	STRUTTURA MURATA DX POPPA	OKOUME' GREZZO	1	Damiano

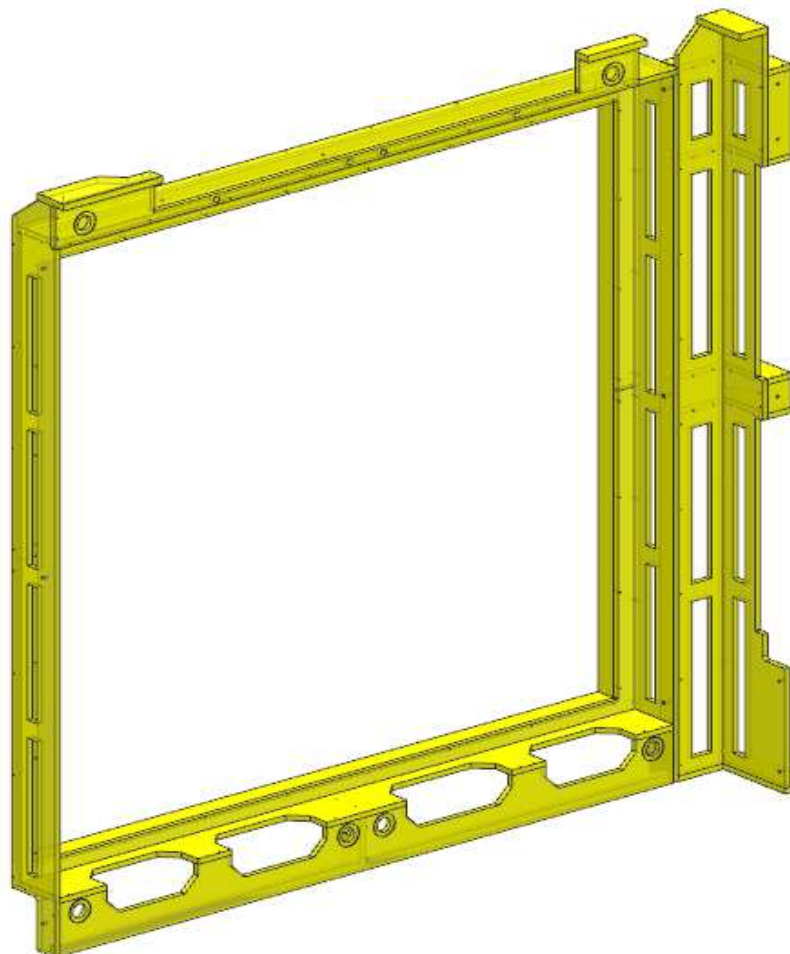

**FERRAMENTA:**

- N° 6 - FITLOCK MASCHIO
- N° 6 - FITLOCK FEMMINA
- N° 4 - FAST MOUNT MASCHIO
- N° 4 - FAST MOUNT FEMMINA
- N° 30 - SPINA diam 8
- N° 4 - BUSSOLA ZAMA 6MA
- N° 6 - VITI 6MA

# AZ26M

REV. 01-2023

REV. GR 9

LOCALE	CODICE	DESCRIZIONE COMPONENTE	FINITURA	Q.TA	OPERATORE
SALONE	AZ26M-SE01	PLENUM MURATA DX POPPA	GREZZO VERNICIATO ANTI ROMBO	1	Damiano

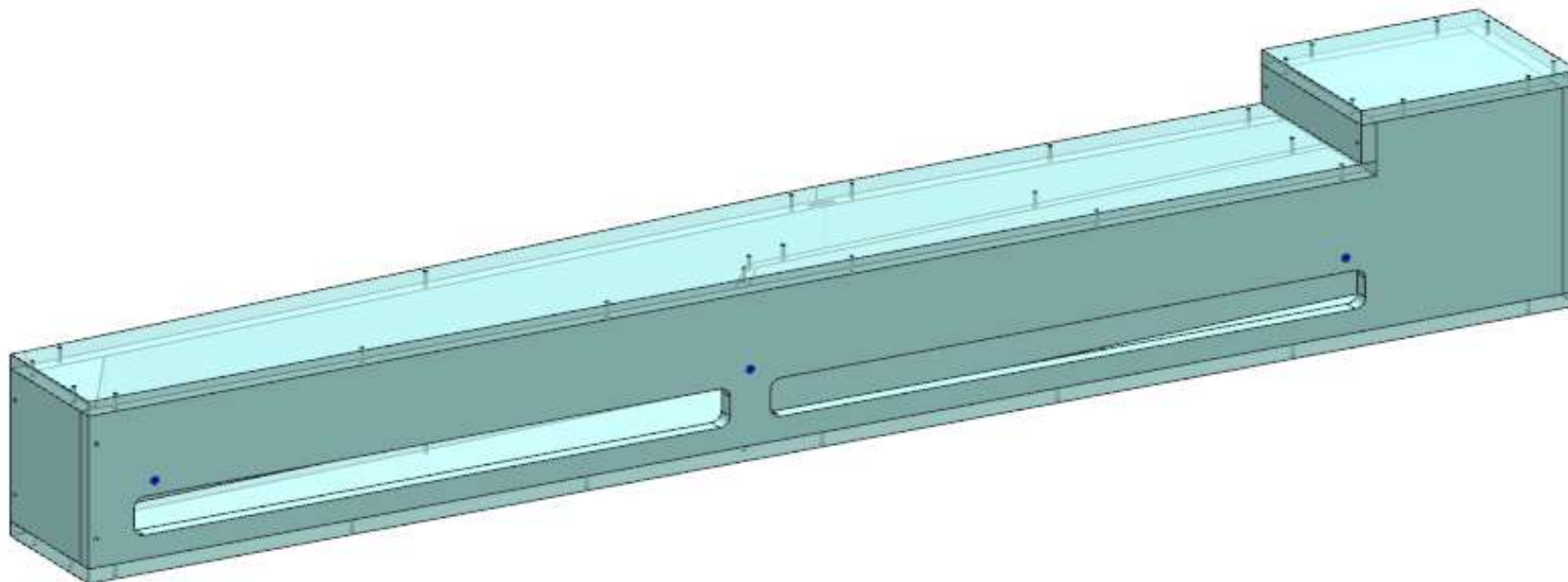

**FERRAMENTA:**

- N° 6 - SPINE diam 8
- N° 6 - BUSSOLA ZAMA 6MA
- N° 3 - VITI 6MA

# AZ26M

REV. GR 9

LOCALE	CODICE	DESCRIZIONE COMPONENTE	FINITURA	Q.TA	OPERATORE
SALONE	AZ26M-SF01	STRUTTURA MURATA SX PRUA	OKOUME' GREZZO	2	Damiano

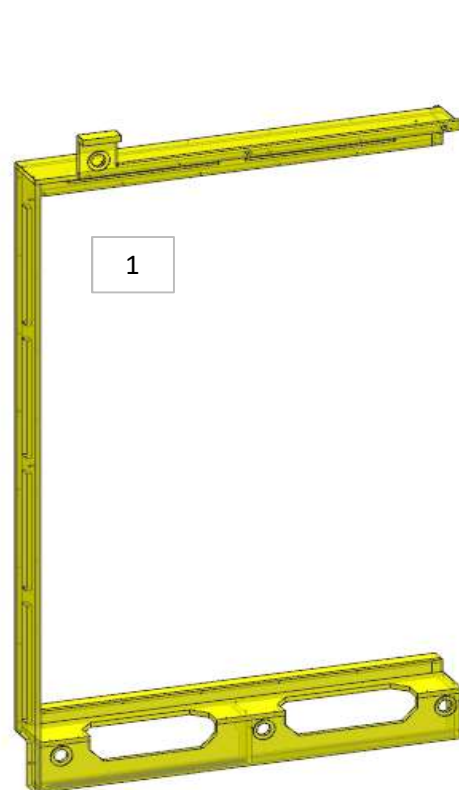

### FERRAMENTA:

- N° 8 - FITLOCK MASCHIO
- N° 8 - FITLOCK FEMMINA
- N° 4 - FAST MOUNT MASCHIO
- N° 4 - FAST MOUNT FEMMINA
- N° 28 - SPINA diam 8
- N° 5 - BUSSOLA ZAMA 6MA
- N° 9 - VITI 6MA

ELEMENTO DA  
MONTARE con:  
**X01\_SF01**  
e spedire con un unico  
imballo

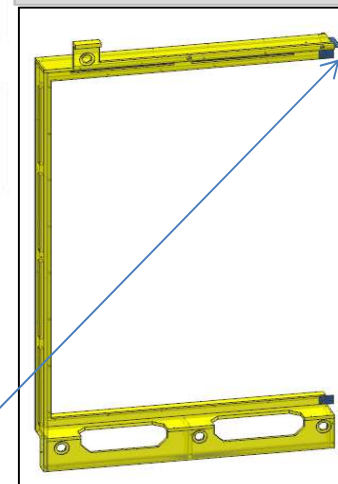

# AZ26M

REV. 01-2023

REV. GR 9

LOCALE	CODICE	DESCRIZIONE COMPONENTE	FINITURA	Q.TA	OPERATORE
SALONE	AZ26M-SG01	PLENUM MURATA SX PRUA	GREZZO VERNICIATO ANTI ROMBO	1	Damiano

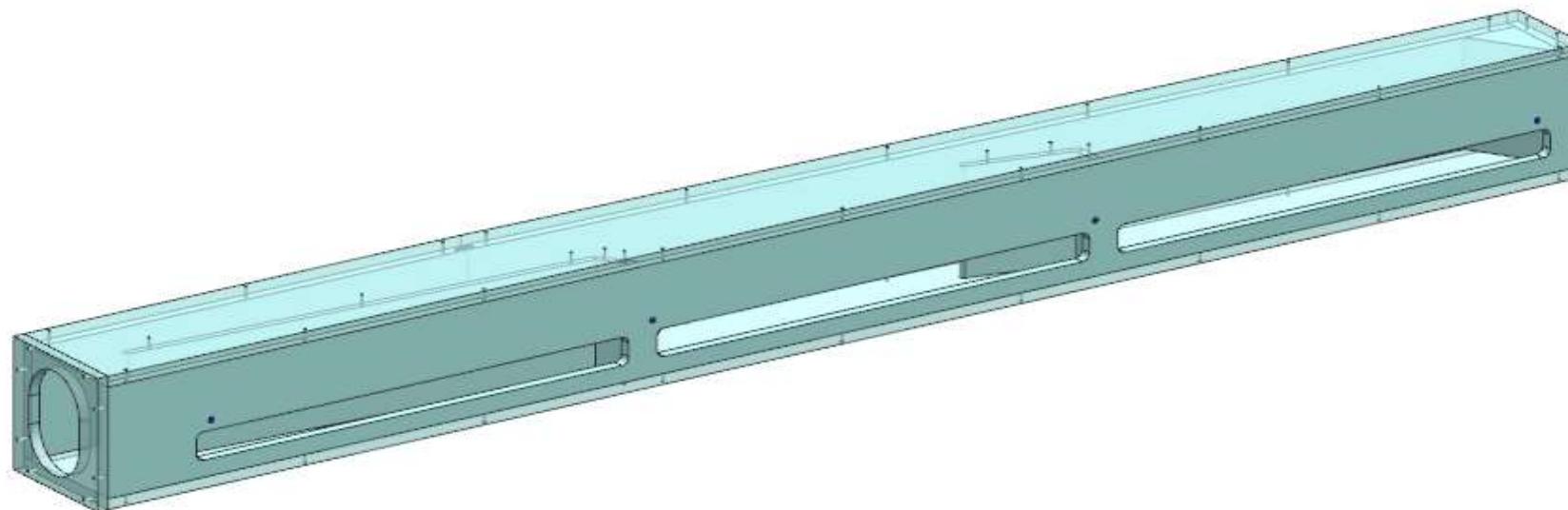

**FERRAMENTA:**

N° 11 - SPINE diam 8  
N° 8 - BUSSOLA ZAMA 6MA  
N° 4 - VITI 6MA

# AZ26M

REV. GR 9

LOCALE	CODICE	DESCRIZIONE COMPONENTE	FINITURA	Q.TA	OPERATORE
SALONE	AZ26M-SH01	STRUTTURA MONTANTE SX	OKOUME' GREZZO	1	Damiano

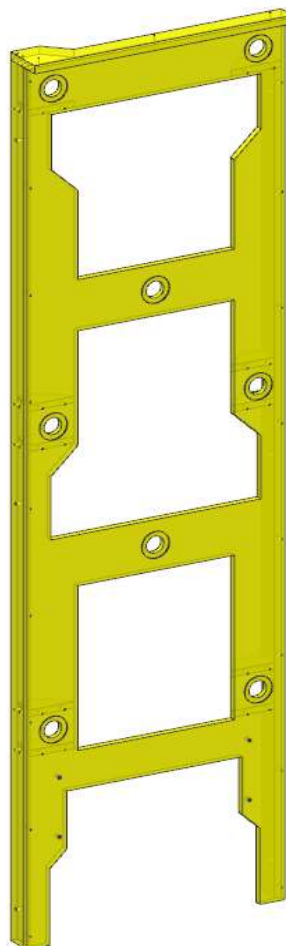

**FERRAMENTA:**

- N° 8 - FITLOCK MASCHIO
- N° 8 - FITLOCK FEMMINA
- N° 4 - BUSSOLA ZAMA 6MA
- N° 6 - VITI 6MA

# AZ26M

MOD GR7

REV. GR 9

LOCALE	CODICE	DESCRIZIONE COMPONENTE	FINITURA	Q.TA	OPERATORE
SALONE	AZ26M-SI01	STRUTTURA MURATA SX POPPA	OKOUME' GREZZO	3	Damiano

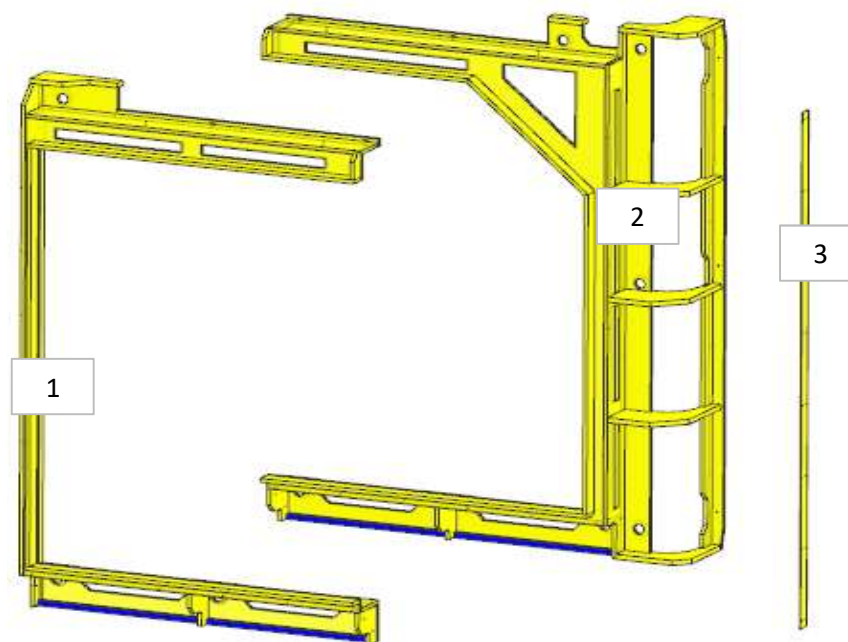

ELEMENTO DA MONTARE  
con:  
**X01\_SI01**  
e spedire con un unico  
imballo

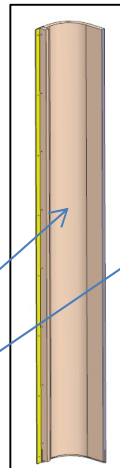
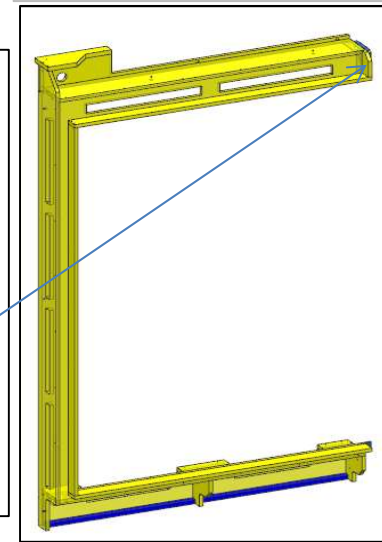

L01\_SI01

X01\_SI01

**FERRAMENTA:**  
N° 11 - FITLOCK MASCHIO  
N° 11 - FITLOCK FEMMINA  
N° 4 - FAST MOUNT MASCHIO  
N° 4 - FAST MOUNT FEMMINA  
N° 30 - SPINA diam 8  
N° 5 - BUSSOLA ZAMA 6MA  
N° 9 - VITI 6MA

# AZ26M

REV. 01-2023

REV. GR 9

LOCALE	CODICE	DESCRIZIONE COMPONENTE	FINITURA	Q.TA	OPERATORE
SALONE	AZ26M-SL01	PLENUM MURATA SX POPPA	GREZZO VERNICIATO ANTI ROMBO	1	Damiano

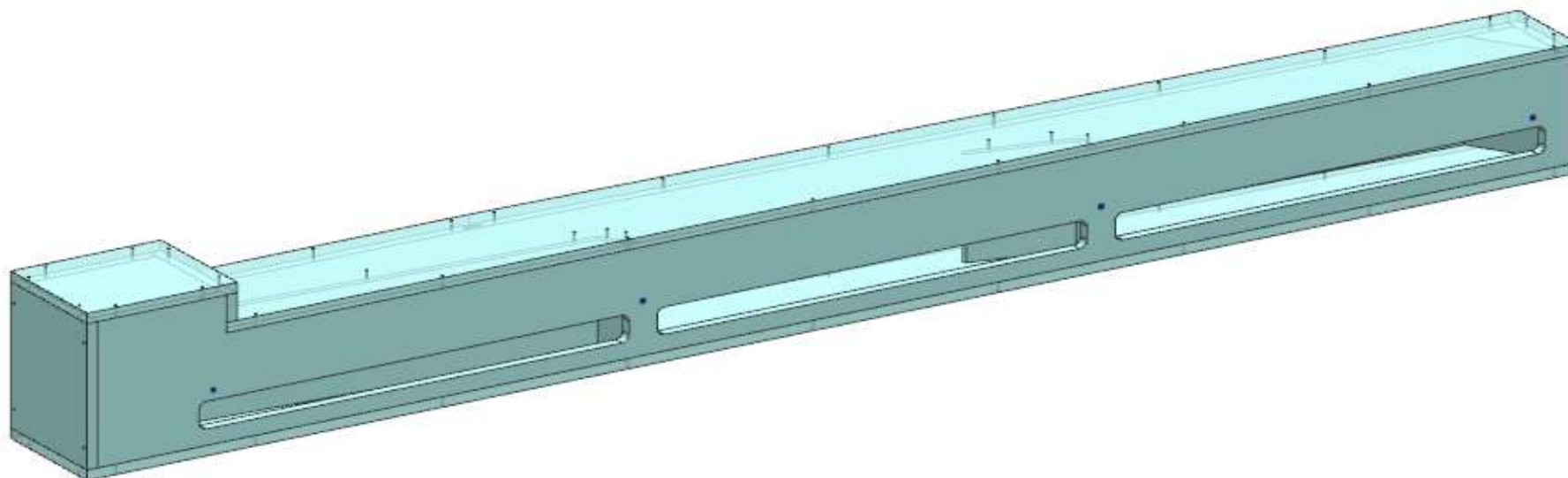

**FERRAMENTA:**

- N° 8 - SPINE diam 8
- N° 8 - BUSSOLA ZAMA 6MA
- N° 4 - VITI 6MA

# AZ26M

MOD DA GR4

REV. GR 9

LOCALE	CODICE	DESCRIZIONE COMPONENTE	FINITURA	Q.TA	OPERATORE
SALONE	AZ26M-SM01	MOBILE COLONNA SX POPPA	LAMINATO NADIR	7	Damiano

**MOD AZ 161**  
modificato mobile per  
aumentare lo storage

#### FERRAMENTA:

- N° 3 - CERNIERA PIANA BLUMOTION 95°
- N° 3 - BASETTA H3 BLUM
- N° 12 - ANKOR BORGHI
- N° 12 - VITI 4 MA x 8 per Ankor borghi
- N° 2 - GOMMINO PARACOLPO
- N° 1 - FLUSH LOCK°
- N° 4 - FITLOCK MASCHIO
- N° 4 - FITLOCK FEMMINA
- N° 19 - BUSSOLA ZAMA 6MA
- N° 16 - VITI 6MA
- N° 8 - SPINA diam 8
- N° 4 - REGGIRIPIANO 1 PERNO 1 FORO
- N° 2 - SOUTHCO

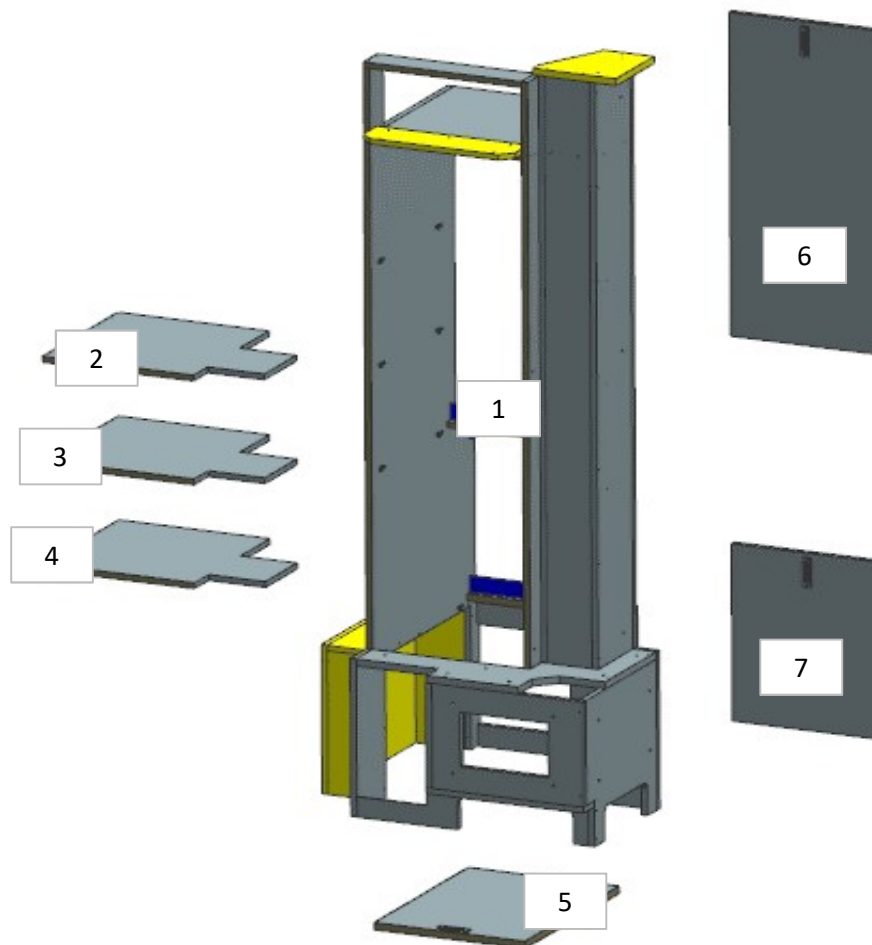

# AZ26M

REV. 01-2023

REV. GR 9

LOCALE	CODICE	DESCRIZIONE COMPONENTE	FINITURA	Q.TA	OPERATORE
SALONE	AZ26M-SN01	COMODINO DX CENTRONAVE	GREZZO SPRUZZATO NERO	1	Damiano

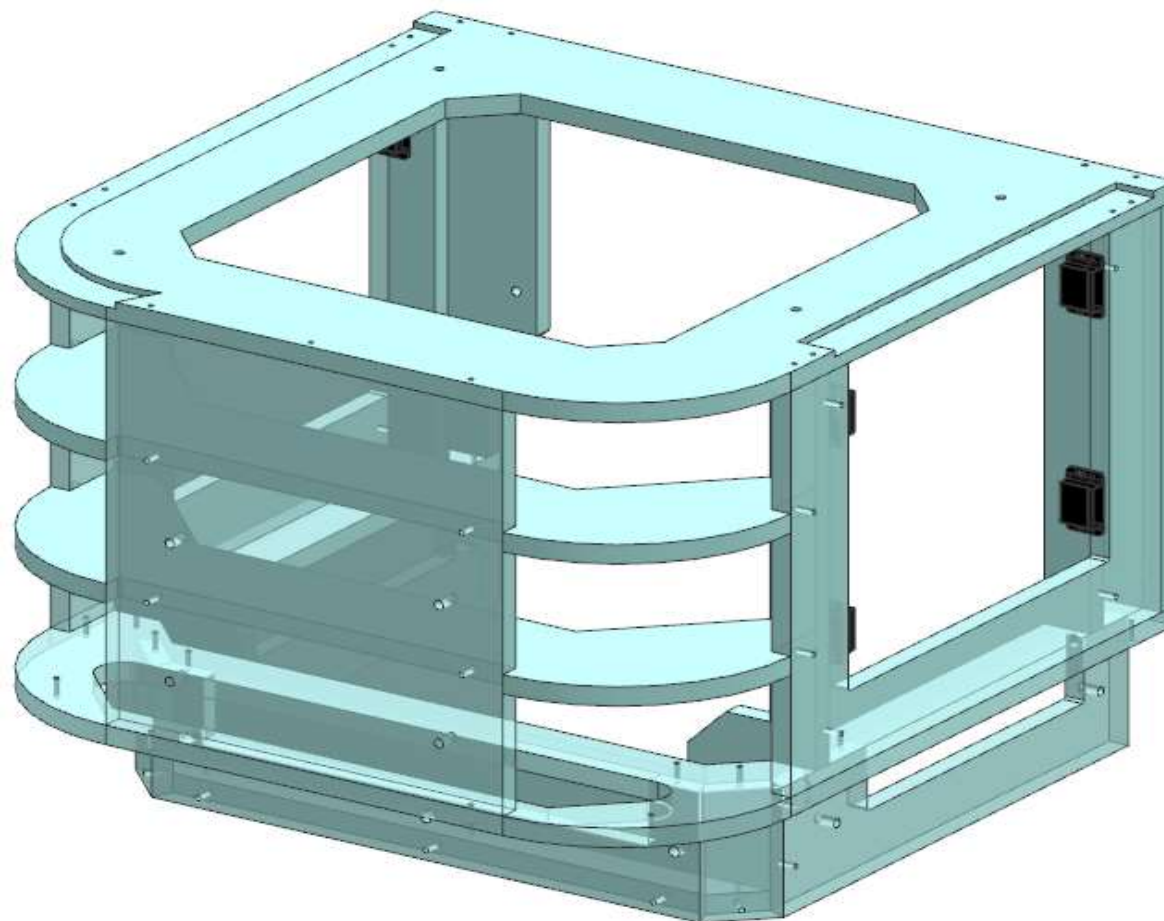

**FERRAMENTA:**

- N° 4 - SOUTCHO
- N° 3 - SPINA diam 8
- N° 12 - BUSSOLA ZAMA 6MA
- N° 16 - VITI 6MA

# AZ26M

REV. 01-2023

REV. GR 9

LOCALE	CODICE	DESCRIZIONE COMPONENTE	FINITURA	Q.TA	OPERATORE
SALONE	AZ26M-S001	COMODINO SX CENTRONAVE	GREZZO SPRUZZATO NERO	1	Damiano

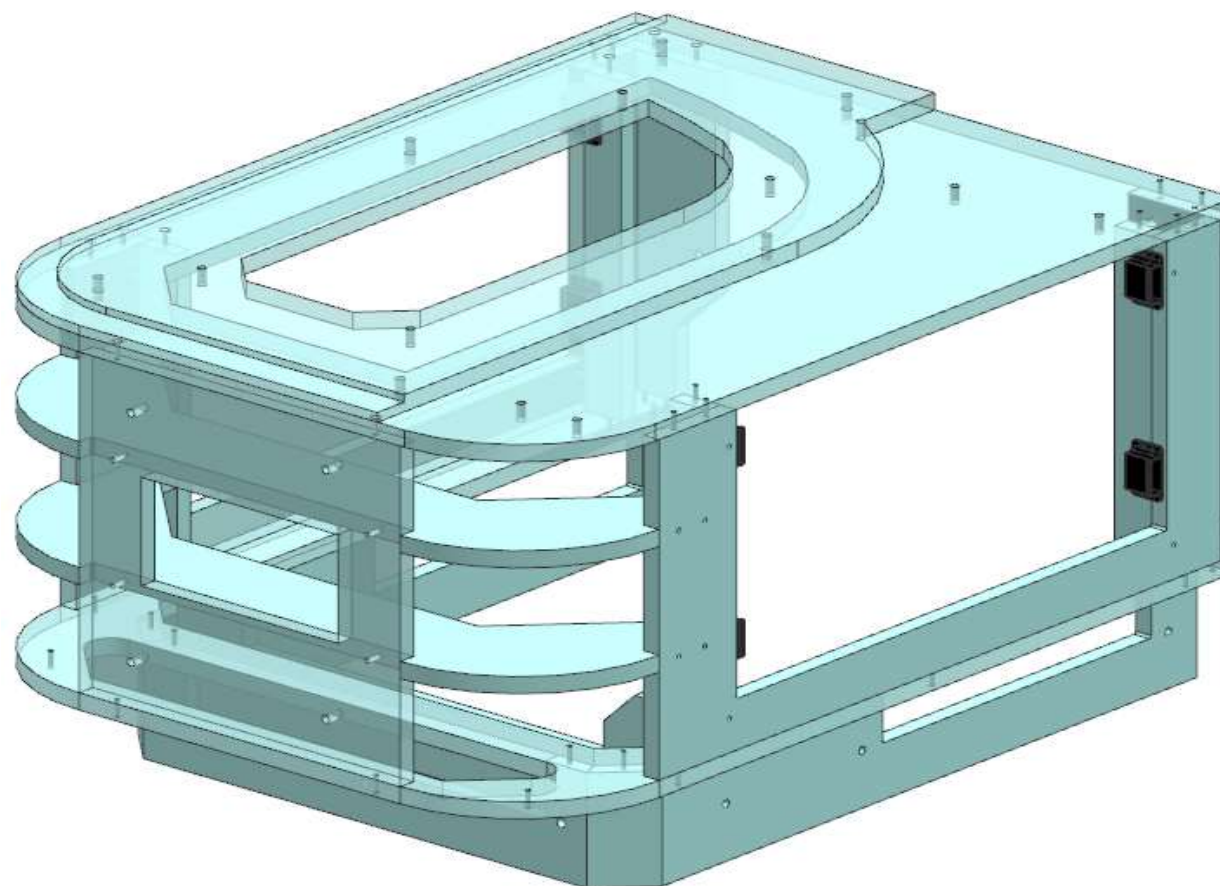

**FERRAMENTA:**

- N° 4 - SOUTCHO
- N° 9 - SPINA diam 8
- N° 18 - BUSSOLA ZAMA 6MA
- N° 20 - VITI 6MA

# AZ26M

REV. 01-2023

REV. GR 9

LOCALE	CODICE	DESCRIZIONE COMPONENTE	FINITURA	Q.TA	OPERATORE
SALONE	AZ26M-SP01	STRUTTURA INGRESSO DX POPPA	OKOUME' GREZZO\ LAMINATO NADIR	2	Damiano

2 - L 425 x H 511 x 200

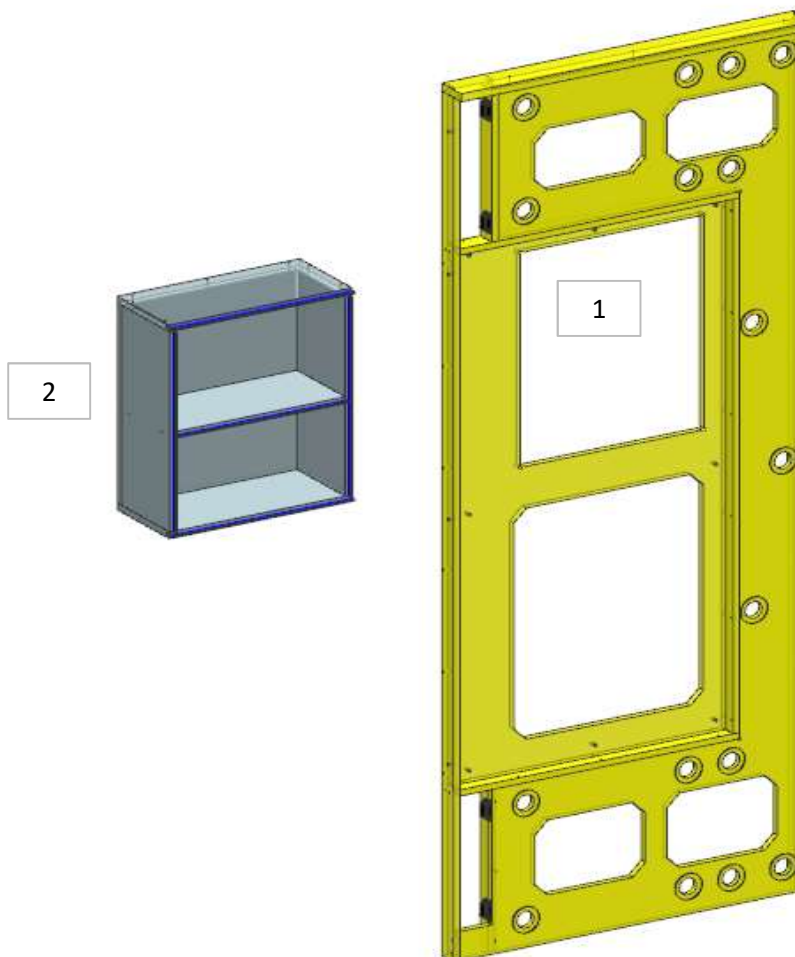

## FERRAMENTA:

- N° 3 - CERNIERA INVISIBILE REGOLABILE
- N° 4 - CALAMITA AD INCASSO diam 15
- N° 17 - FITLOCK MASCHIO
- N° 17 - FITLOCK FEMMINA
- N° 14 - SPINA diam 8
- N° 4 - SOUTCHO
- N° 12 - BUSSOLA ZAMA 6MA
- N° 8 - VITI 6MA

# AZ26M

MOD DA GR4

REV. GR 9

LOCALE	CODICE	DESCRIZIONE COMPONENTE	FINITURA	Q.TA	OPERATORE
SALONE	AZ26M-SQ01	MOBILE IN NICCHIA DX POPPA	OKOUME' GREZZO / LAMINATO NADIR	3	Damiano

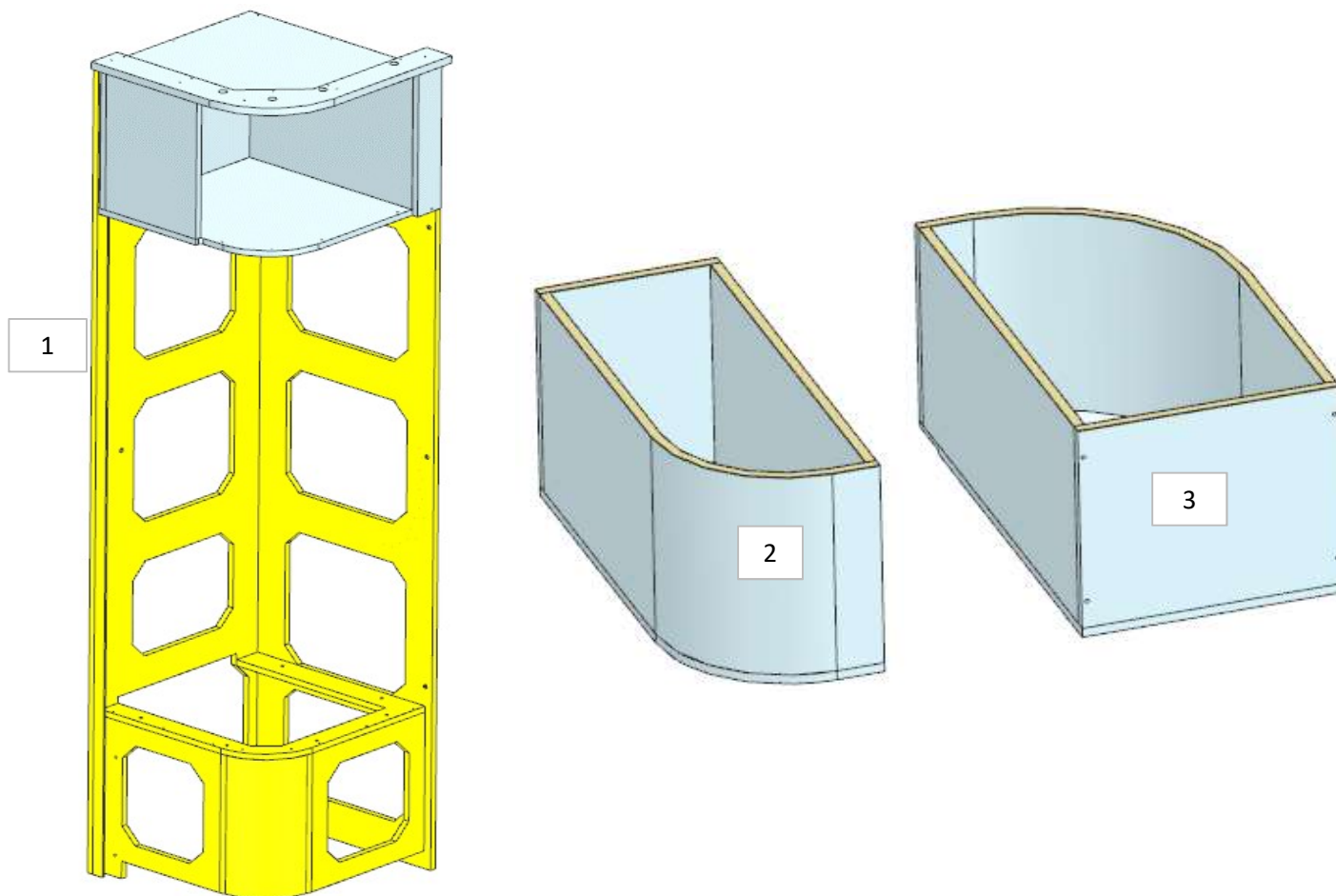

**FERRAMENTA:**

- N° 9 - SPINA diam 8
- N° 2 - SOUTCHO
- N° 12 - BUSSOLA ZAMA 6MA
- N° 21 - VITI 6MA
- N° 1 - ALZAPAIOLO

# AZ26M

REV. 01-2023

REV. GR 9

LOCALE	CODICE	DESCRIZIONE COMPONENTE	FINITURA	Q.TA	OPERATORE
SALONE	AZ26M-SR01	MOBILE SUBWOOFER SX POPPA	GREZZO SPRUZZATO NERO	1	Damiano

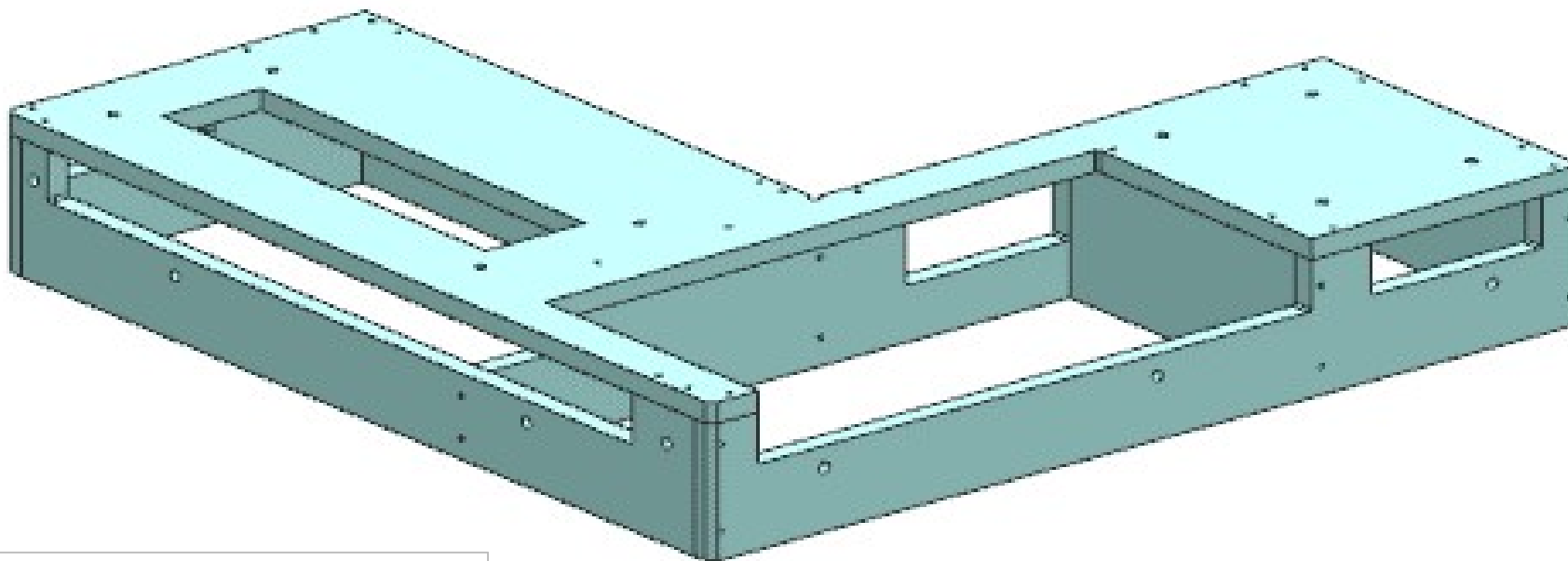

**FERRAMENTA:**

- N° 2 - CERNIERA INVISIBILE REGOLABILE
- N° 1 - ALZA PAIOLO
- N° 6 - SOUTCHO
- N° 38 - SPINA diam 8
- N° 17 - BUSSOLA ZAMA 6MA

# AZ26M

MOD DA GR10

REV. GR 10

LOCALE	CODICE	DESCRIZIONE COMPONENTE	FINITURA	Q.TA	OPERATORE
SALONE	AZ26M-SS01	CIELINO DI POPPA	CARTA MELAMINICA NERA	8	Dante

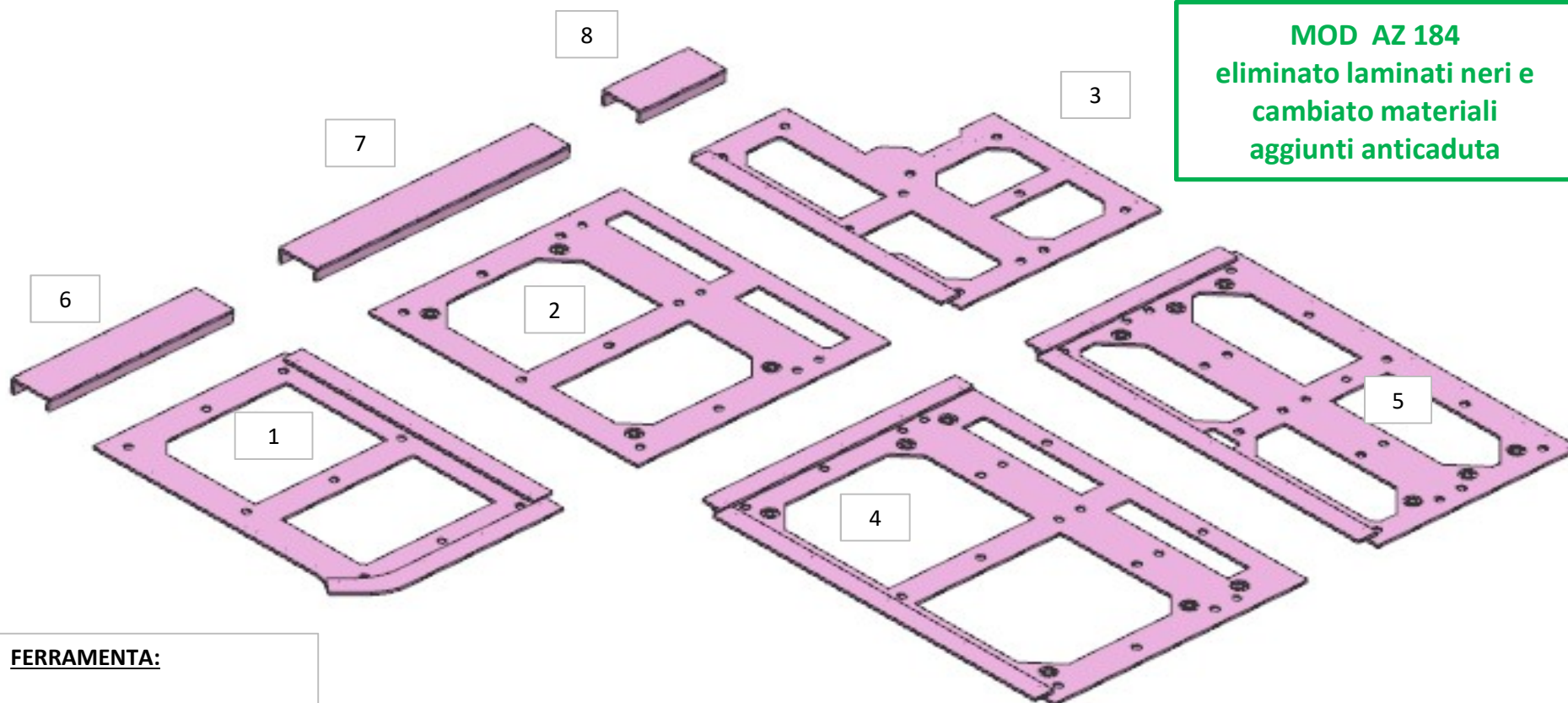

**MOD AZ 184**  
eliminato laminati neri e  
cambiato materiali  
aggiunti anticaduta

**FERRAMENTA:**

N° 43 - FITLOCK MASCHIO  
N° 43 - FITLOCK FEMMINA

# AZ26M

MOD DA GR10

REV. GR 10

LOCALE	CODICE	DESCRIZIONE COMPONENTE	FINITURA	Q.TA	OPERATORE
SALONE	AZ26M-ST01	CIELINO CENTRALE	CARTA MELAMINICA NERA	5	Dante

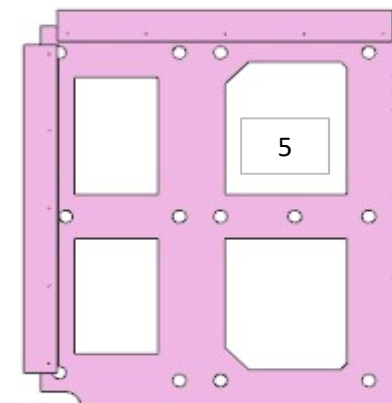
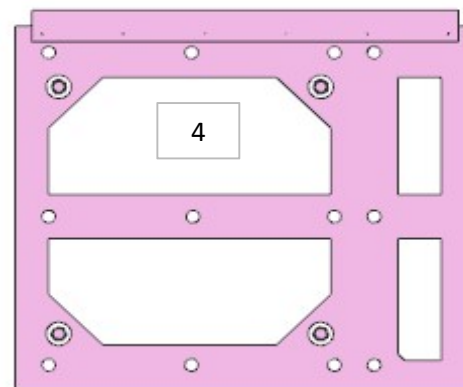
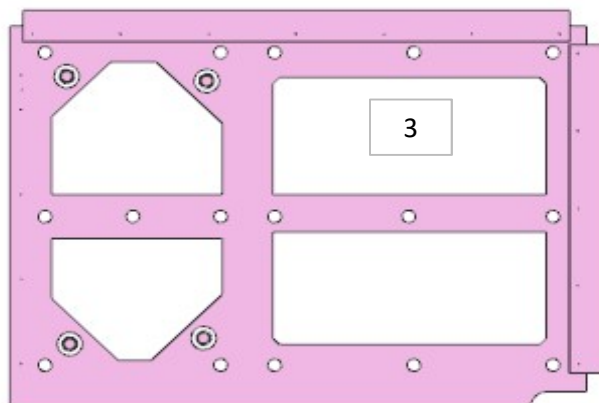
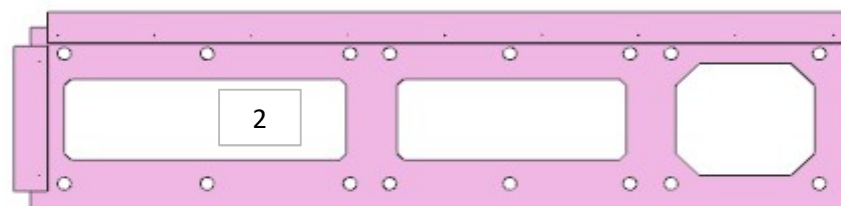
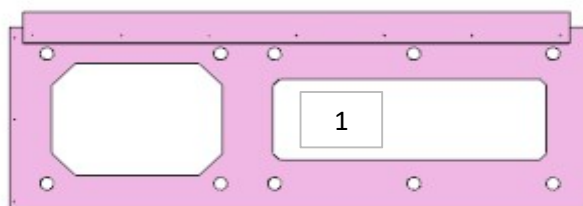

**FERRAMENTA:**

N° 49 - FITLOCK MASCHIO  
N° 49 - FITLOCK FEMMINA

**MOD AZ 184**  
eliminato laminati neri e  
cambiato materiali  
aggiunti anticaduta

# AZ26M

MOD DA GR10

REV. GR 10

LOCALE	CODICE	DESCRIZIONE COMPONENTE	FINITURA	Q.TA	OPERATORE
SALONE	AZ26M-SU01	CIELINO PRUA	CARTA MELAMINICA NERA	5	Dante

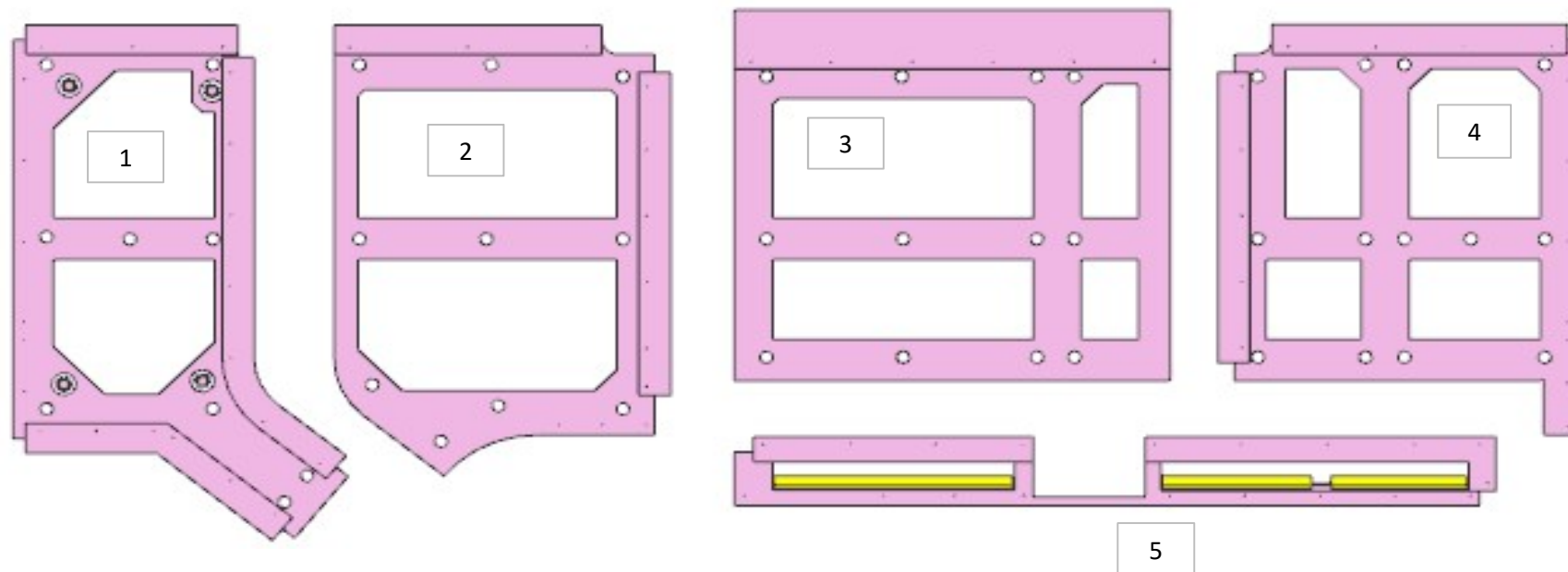

**FERRAMENTA:**

N° 26 - FITLOCK MASCHIO  
N° 26 - FITLOCK FEMMINA

**MOD AZ 184**  
eliminato laminati neri e  
cambiato materiali  
aggiunti anticaduta

# AZ26M

REV. GR 9

LOCALE	CODICE	DESCRIZIONE COMPONENTE	FINITURA	Q.TA	OPERATORE
SALONE	AZ26M-SV01	STRUTT. SPESSORAMENTO RIV. PRUA	OKOUME' GREZZO	2	Dante

**FERRAMENTA:**

N° 43 - FITLOCK MASCHIO  
N° 43 - FITLOCK FEMMINA

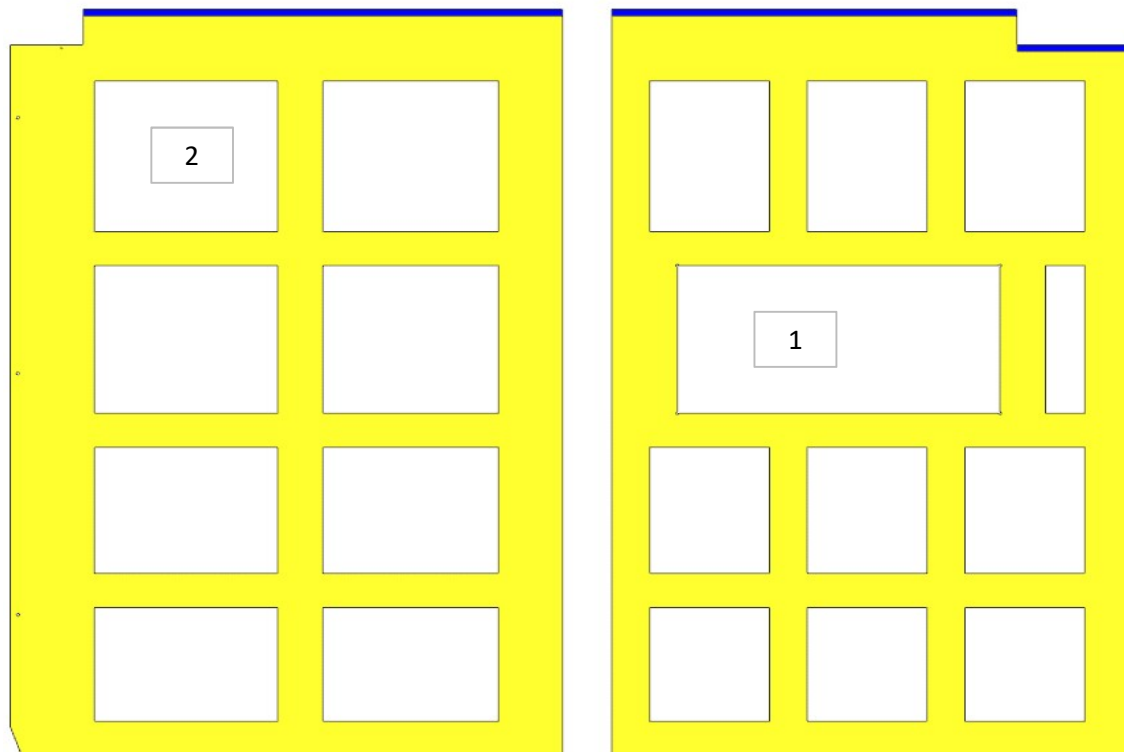

**FERRAMENTA:**

N° 3 - BUSSOLA ZAMA 6MA  
ML 2,2 - PIATTINE IN ACCIAIO PREFORATO sp 2mm

# AZ26M

MOD DA GR10

REV. GR 10

LOCALE	CODICE	DESCRIZIONE COMPONENTE	FINITURA	Q.TA	OPERATORE
SALONE	AZ26M-SY01	CIELINO ZONA TV A DISCESA	CARTA MELAMINICA NERA	3	Dante

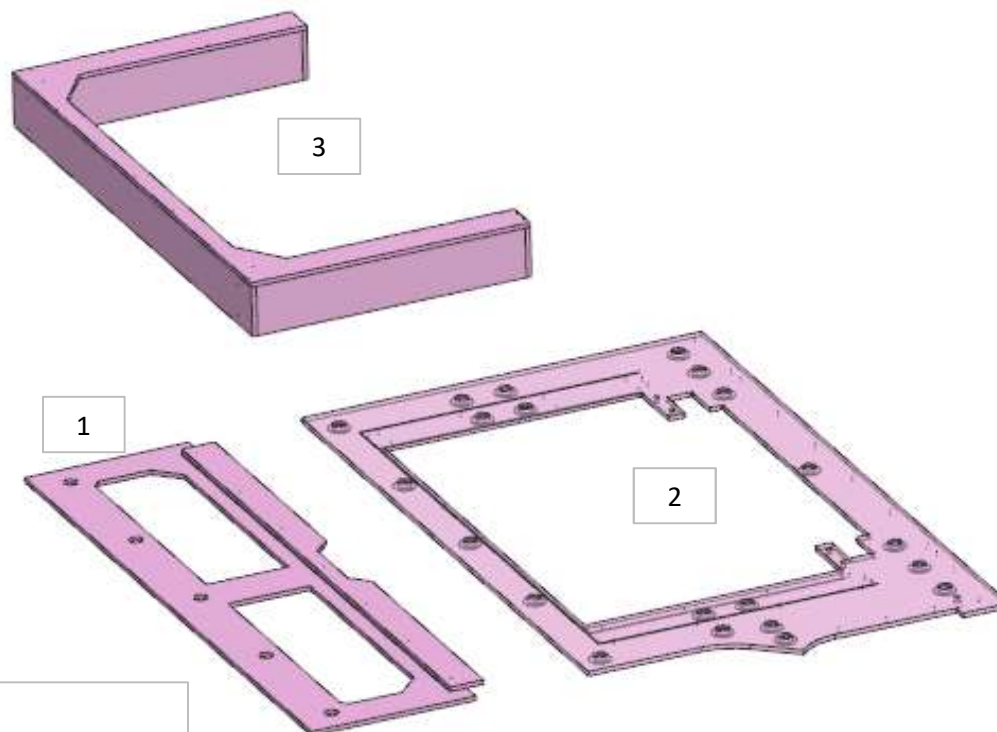

**MOD AZ 184**  
eliminato laminati neri e  
cambiato materiali

**ELEMENTO DA MONTARE INSIEME:**  
**MG\_SY01**  
e spedire con un unico imballo

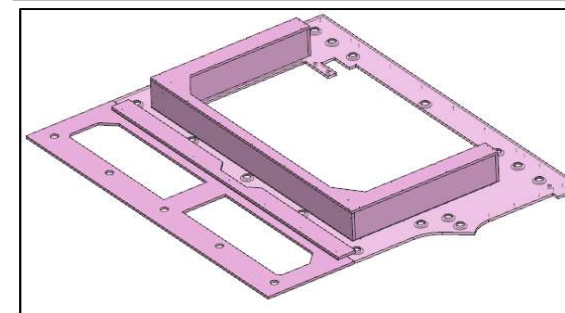

**FERRAMENTA:**  
N° 20 - FITLOCK MASCHIO  
N° 20 - FITLOCK FEMMINA  
N° 4 - FAST MOUNT MASCHIO  
N° 4 - FAST MOUNT FEMMINA