

AZ26M

REV. 01-2023

REV. GR 9

LOCALE	CODICE	DESCRIZIONE COMPONENTE	FINITURA	Q.TA	OPERATORE
TIMONERIA	AZ26M-R01_TA01	MOBILE QUADRI ELETTRICI	LASTRA CHIARA	10	Damiano

- 1 - L.1803 x H 874 x sp 20
- 2 - 3 - 4 - 5 - L.427 x H 619 x sp 20
- 6 - 10 - L.1751 x H 80 x sp 16
- 7 - 9 - L. 80 x H 623 x sp 16
- 8 - L.79 x H 623 x sp 20

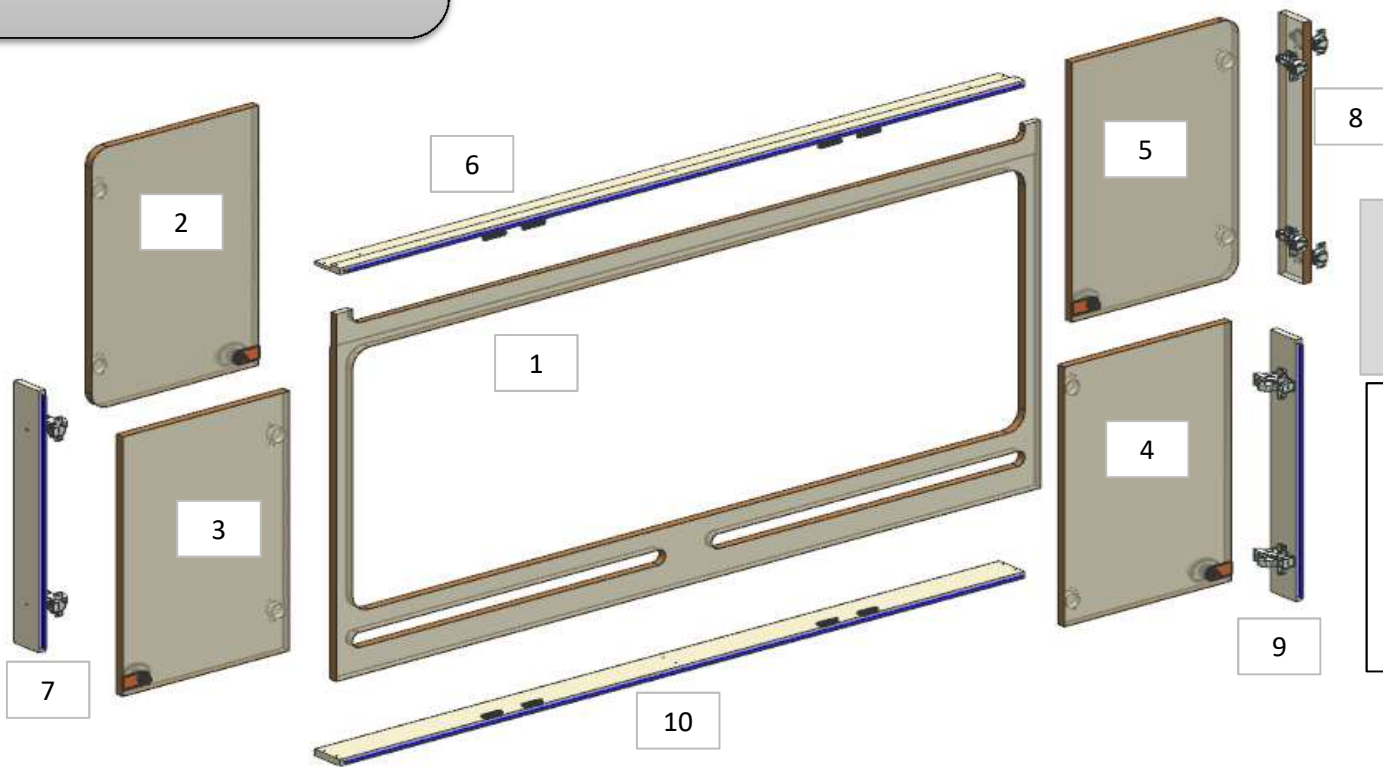

**ELEMENTO DA MONTARE con:
MG01
e spedire con un unico imballo**

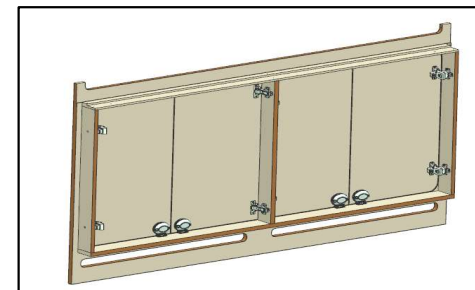

AZ26M

REV. 01-2023

REV. GR 9

LOCALE	CODICE	DESCRIZIONE COMPONENTE	FINITURA	Q.TA	OPERATORE
TIMONERIA	AZ26M-R01_TC01	STRUTTURA SX LATERALE QUADRI	LASTRA CHIARA	3	Damiano

- 1 - L 788 x H.852 x sp 16
- 2 - L 240 x H.852 x sp 16
- 3 - L 253 x H.875 x sp 16

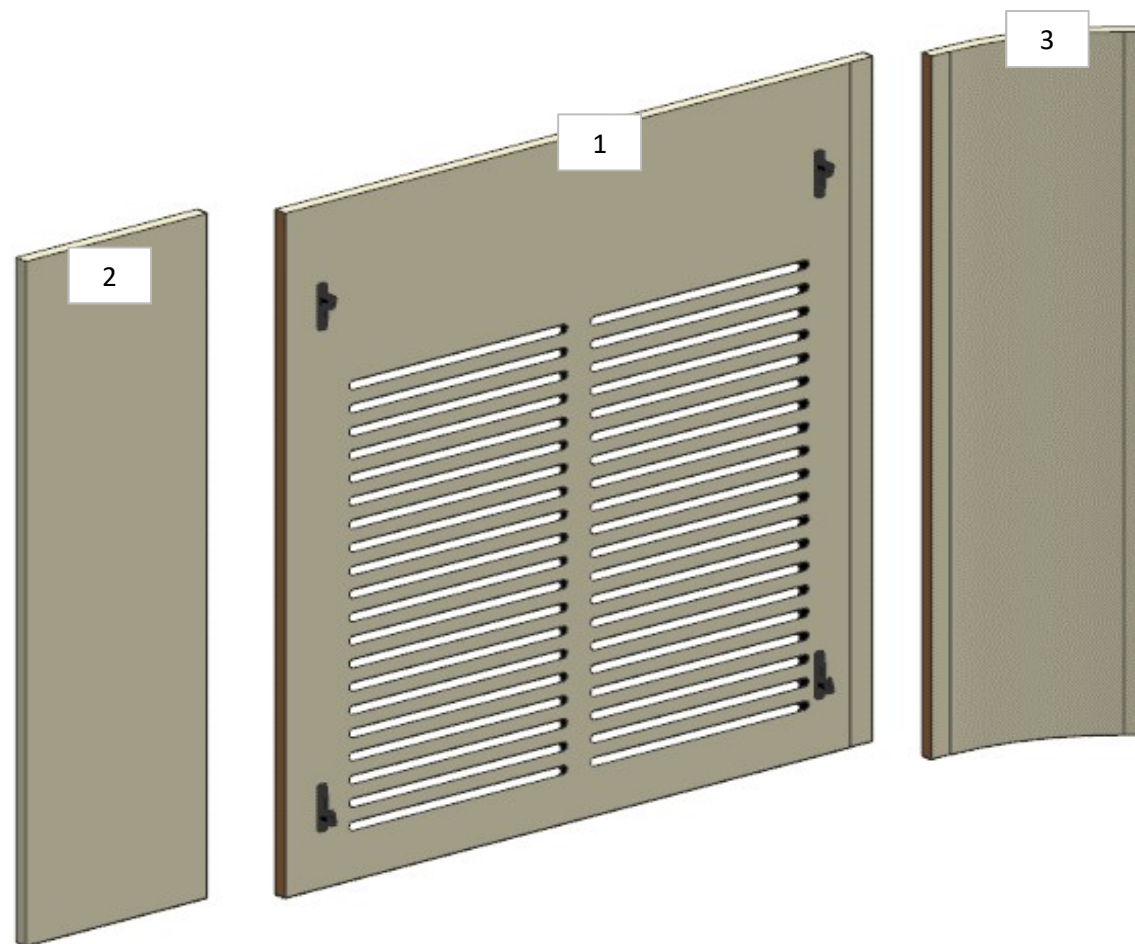

AZ26M

REV. 01-2023

REV. GR 9

LOCALE	CODICE	DESCRIZIONE COMPONENTE	FINITURA	Q.TA	OPERATORE
TIMONERIA	AZ26M-R01_TD01	STRUTTURA DX LATERALE QUADRI	LASTRA CHIARA	3	Damiano

- 1 - L 778 x H.852 x sp 16
- 2 - L 253 x H.875 x sp 16
- 3 - L 240 x H.852 x sp 16

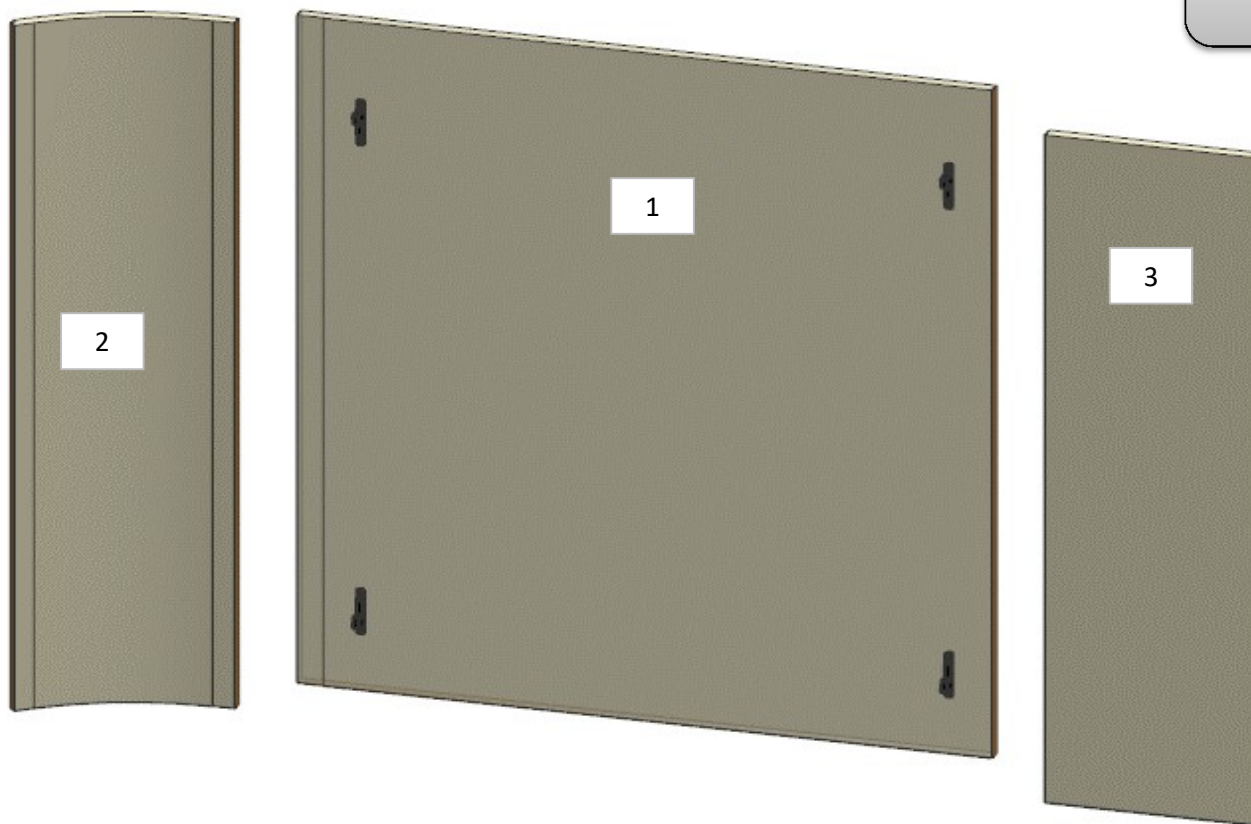

AZ26M

REV. GR 9

LOCALE	CODICE	DESCRIZIONE COMPONENTE	FINITURA	Q.TA	OPERATORE
TIMONERIA	AZ26M-R01_TE01	STRUTTURA FRONTALE SOTTO Q.E.	LASTRA CHIARA	3	Damiano

- 1 - L.61 x H.633 x 61
- 2 - L.1114 x H.633 x sp 11
- 3 - L.975 x H.633 x sp 11

1



2

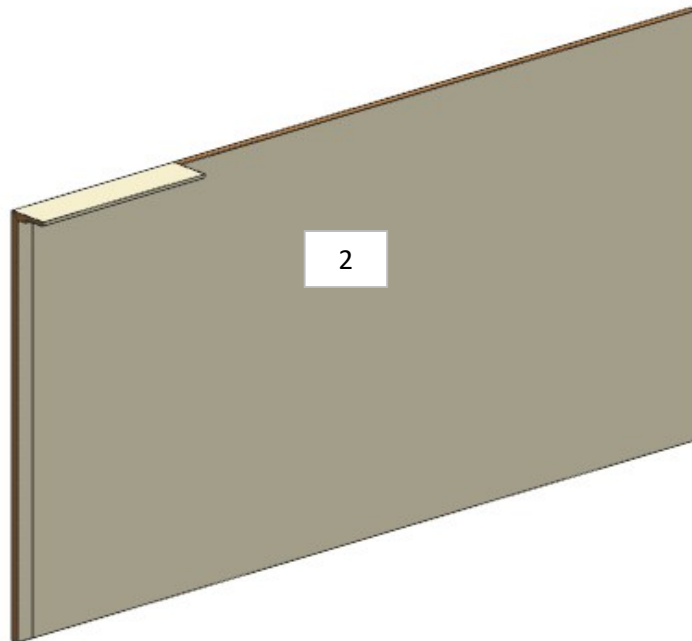

3

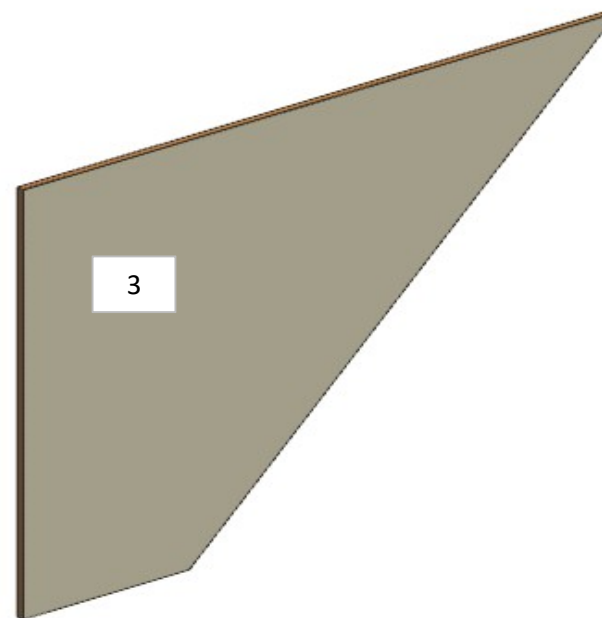

ELEMENTO DA
MONTARE con:
X01_TE01
e spedire con un unico
imballo

X01_TE01

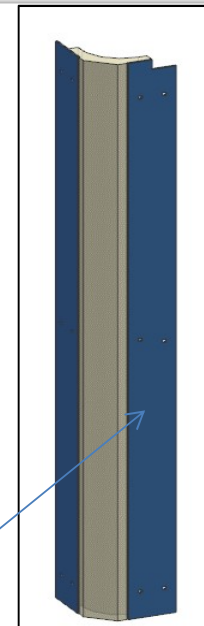

AZ26M

MOD DA GR9

REV. GR 9

LOCALE	CODICE	DESCRIZIONE COMPONENTE	FINITURA	Q.TA	OPERATORE
TIMONERIA	AZ26M-R01_TM01	STRUTTURA CIELINO DX	LASTRA CHIARA	1	Damiano

1 - DIAM 720 x H 91

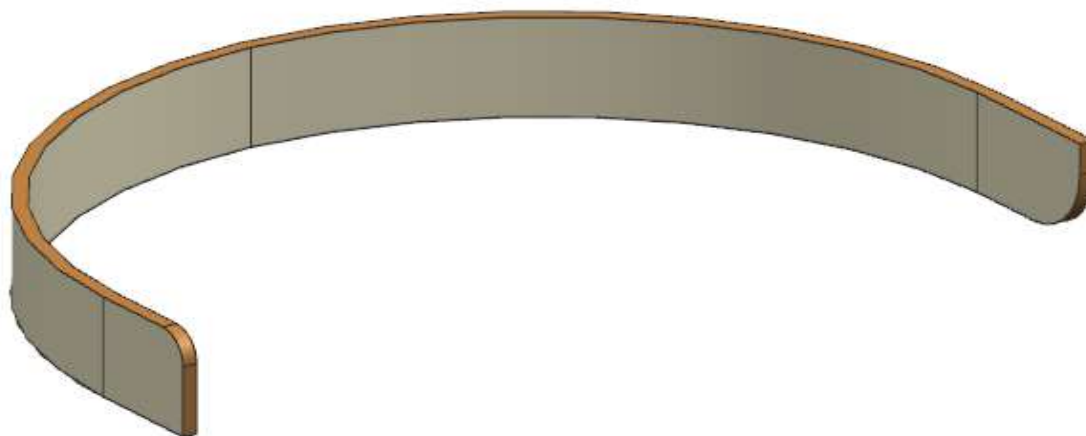

MOD AZ 244
ALLUNGATO LA VELETTA
IN ESSENZA IN MANIERA
DA COPRIRE LA TESTA DEI
PANNELLI CIELINO LOBBY

MODV AZ 180
ALLARGATO TUTTI I BORDI
DEI PANNELLI STOFFATI
NERI DI 3mm.

MOD AZ 259
ALLUNGATA FASCIA
ESSENZA PER OPRIRE GAP
TRA STRUTTURA E CIELINO

AZ26M

REV. GR 9

LOCALE	CODICE	DESCRIZIONE COMPONENTE	FINITURA	Q.TA	OPERATORE
TIMONERIA	AZ26M-R01_TN01	RIV. PARETE TIENTIBENE	LASTRA CHIARA	5	Damiano

- 1 - L 547 x H.1330 x sp 11
- 2 - L 75 x H.92 x sp 51
- 3 - L 75 x H.914 x sp 51
- 4 - L 2130 x H.592 x sp 11
- 5 - L 113 x H 2051 x sp 11

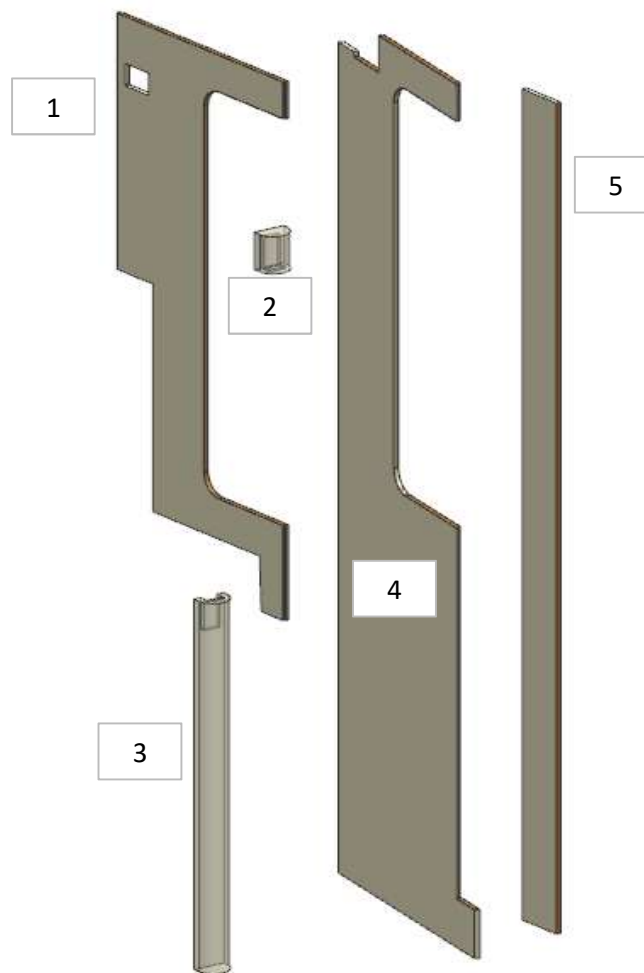

FERRAMENTA:

N° 9 SPINA diam 8

AZ26M

REV. GR 9

LOCALE	CODICE	DESCRIZIONE COMPONENTE	FINITURA	Q.TA	OPERATORE
TIMONERIA	AZ26M-R01_TO01	STRUTTURA CIELINO SX	LASTRA CHIARA	1	Damiano

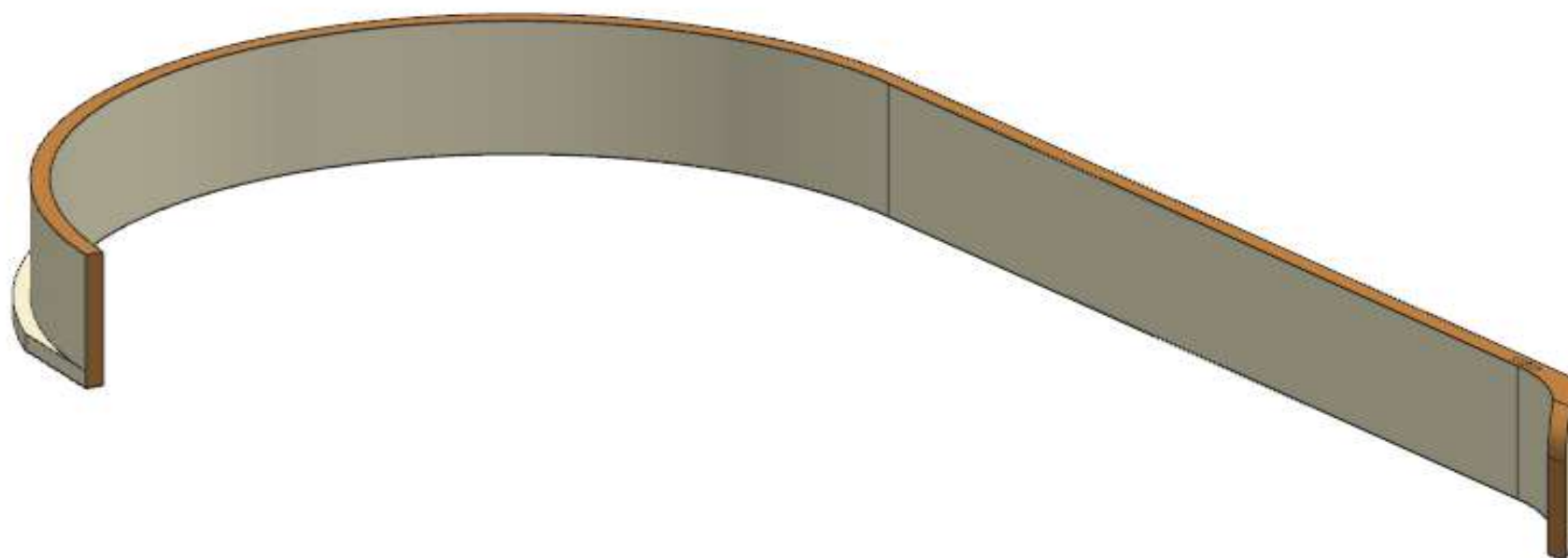

AZ26M

MOD GR4

REV. GR 9

LOCALE	CODICE	DESCRIZIONE COMPONENTE	FINITURA	Q.TA	OPERATORE
SALONE	AZ26M-R01_TQ01	MOBILETTO ALLARMI TIMONERIA	LASTRA CHIARA	1	Damiano

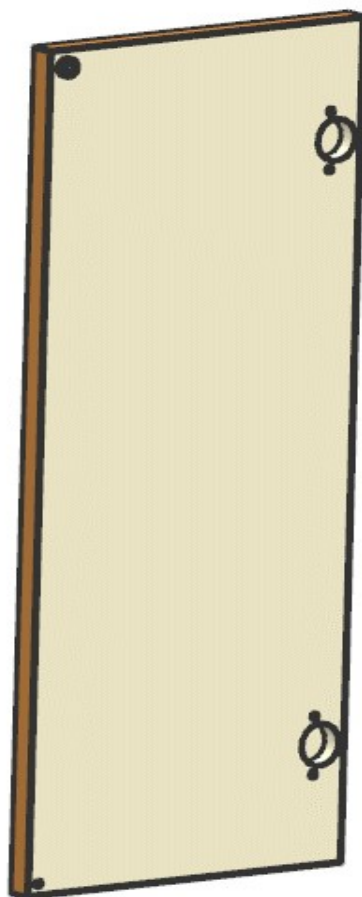

1 - L.290 x H 701 x sp 11

MOD AZ 167
aggiunto storage:
a mano da GR1
di serie da GR 4

AZ26M

REV. GR 9

LOCALE	CODICE	DESCRIZIONE COMPONENTE	FINITURA	Q.TA	OPERATORE
TIMONERIA	AZ26M-R01_TR01	RIV. DISCESA SCALE LATO MARINAIO	LASTRA CHIARA	6	Damiano

- 1 - L.575 x H 1435 x sp 11
- 2 - L.456 x H 1854 x sp 11
- 3 - L.280 x H 75 x sp 11
- 4 - L.246 x H 2054 x sp 11
- 5 - L.278 x H 2556 x sp 11
- 6 - L.560 x H 2051 x sp 11

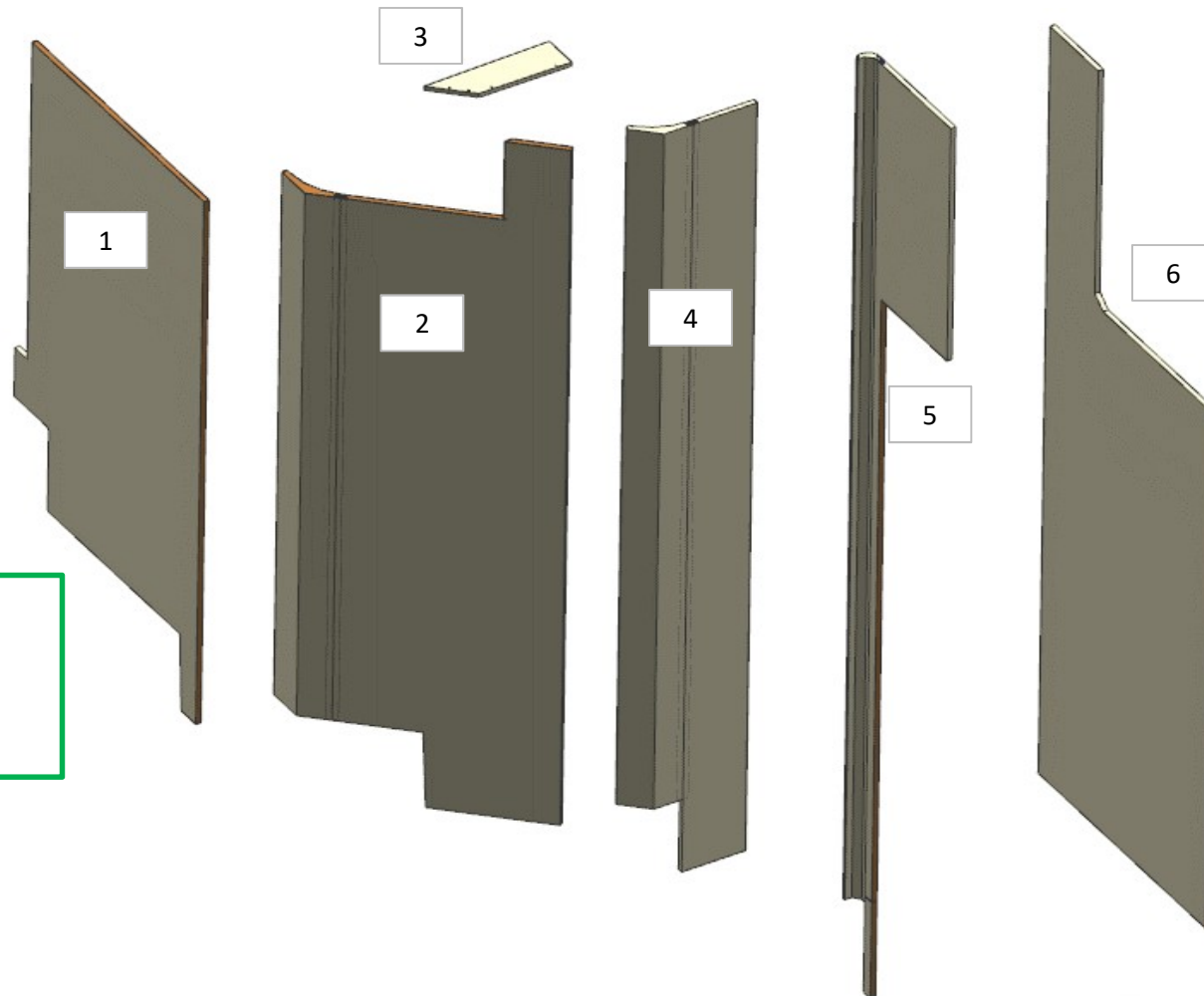

MOD AZ 199
pannello verticale
lastra più largo

AZ26M

MOD GR5

REV. GR 9

LOCALE	CODICE	DESCRIZIONE COMPONENTE	FINITURA	Q.TA	OPERATORE
TIMONERIA	AZ26M-R01_TS01	PARETE OBLO'	LASTRA CHIARA	3	Damiano

MOD AZ 201
Aumentato diametro foro L.
533

MOD AZ 199
pannello verticale
lastra più largo

MOD AZ 202
separato parte
sagomata per plenum

1 - L 750 x H 2092 x sp 16
2 - L 750 x H 505 x sp 16
3 - L 395 x H 124 x sp 16

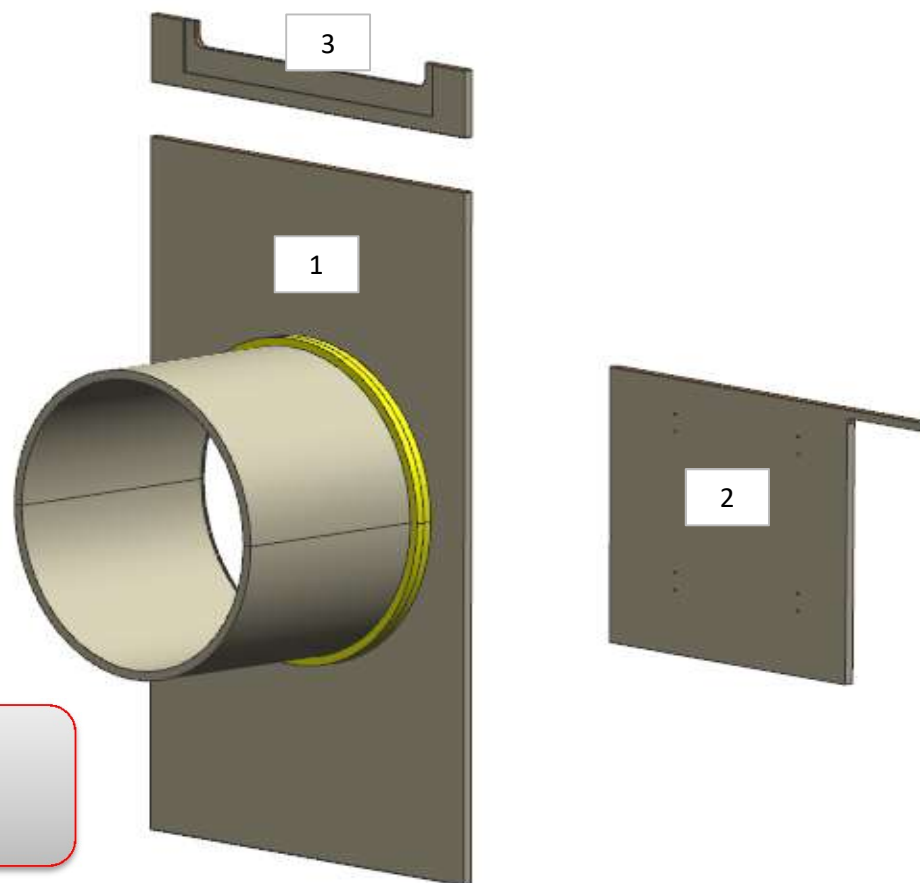

AZ26M

REV. GR 9

LOCALE	CODICE	DESCRIZIONE COMPONENTE	FINITURA	Q.TA	OPERATORE
TIMONERIA	AZ26M-R01_TU01	BLOCCO CENTRALE CRUSCOTTO TIMONERIA	LASTRA CHIARA	2	Damiano

1 - L 845 x H 838 x sp 11
2 - L 545 x H 838 x sp 11

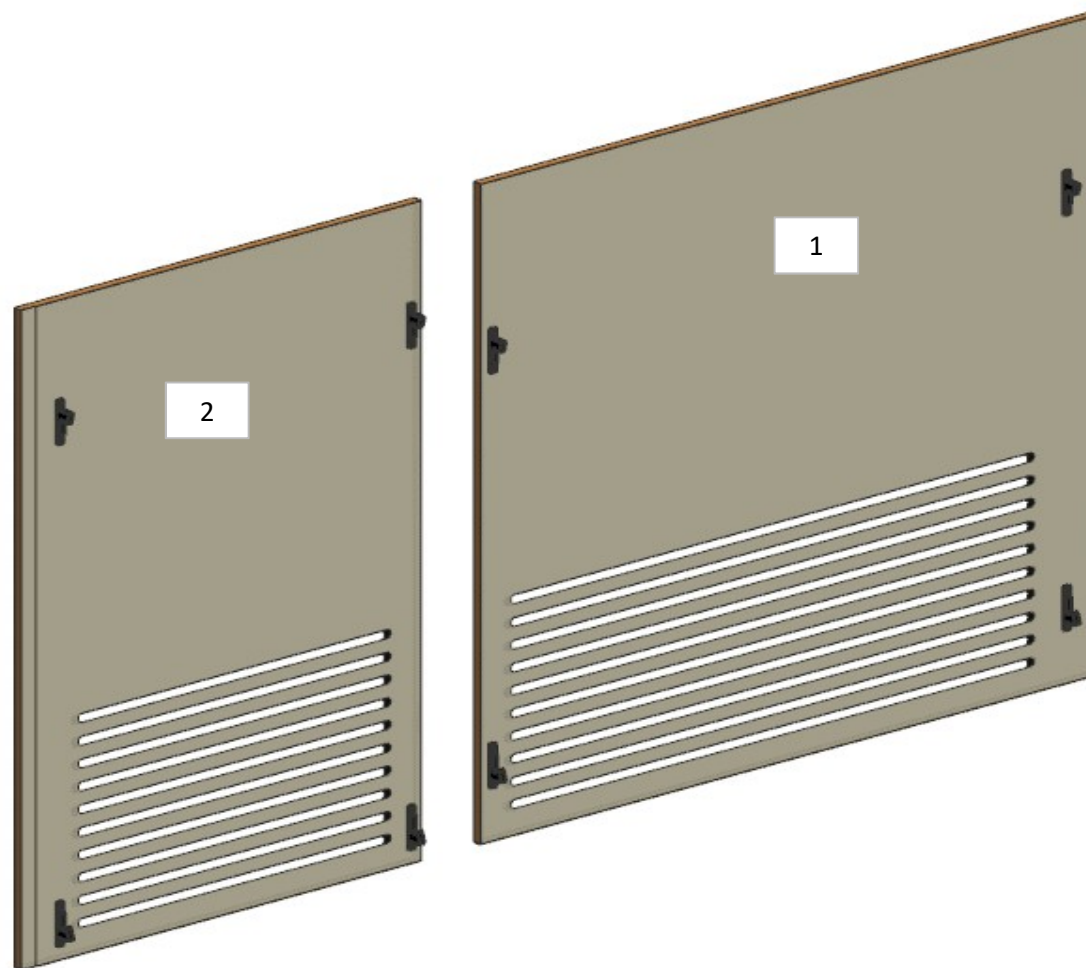

consonni&c

AZ26M

REV. GR 9

LOCALE	CODICE	DESCRIZIONE COMPONENTE	FINITURA	Q.TA	OPERATORE
TIMONERIA	AZ26M-R01_TV01	RIV. DISCESA SCALE LATO ARMATORE	LASTRA CHIARA	2	Damiano

1 - L 580 x H 1825 x sp 11
2 - L 505 x H 1070 x sp 11

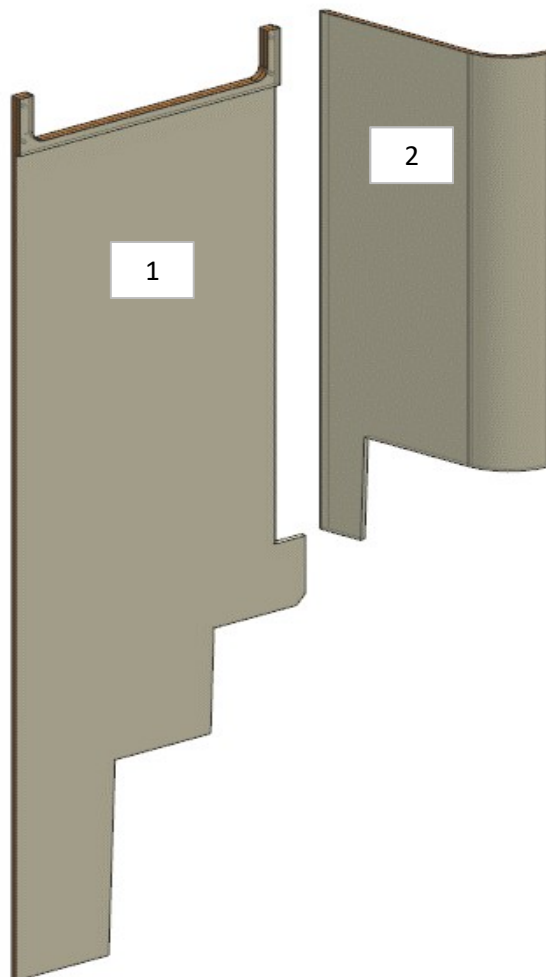

ELEMENTO DA
MONTARE con:
X01_TV01
e spedire con un
unico imballo

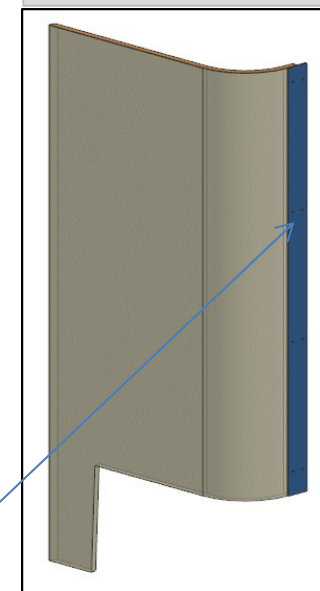

X01_TV01

FERRAMENTA:

N° 4 - SPINA diam 8

consonni&c

AZ26M

MOD GR4

REV. GR 9

LOCALE	CODICE	DESCRIZIONE COMPONENTE	FINITURA	Q.TA	OPERATORE
TIMONERIA	AZ26M-R01_TX01	RIV. GRADINI DISCESA MARINAIO	LASTRA CHIARA	19	Damiano

eliminato MF

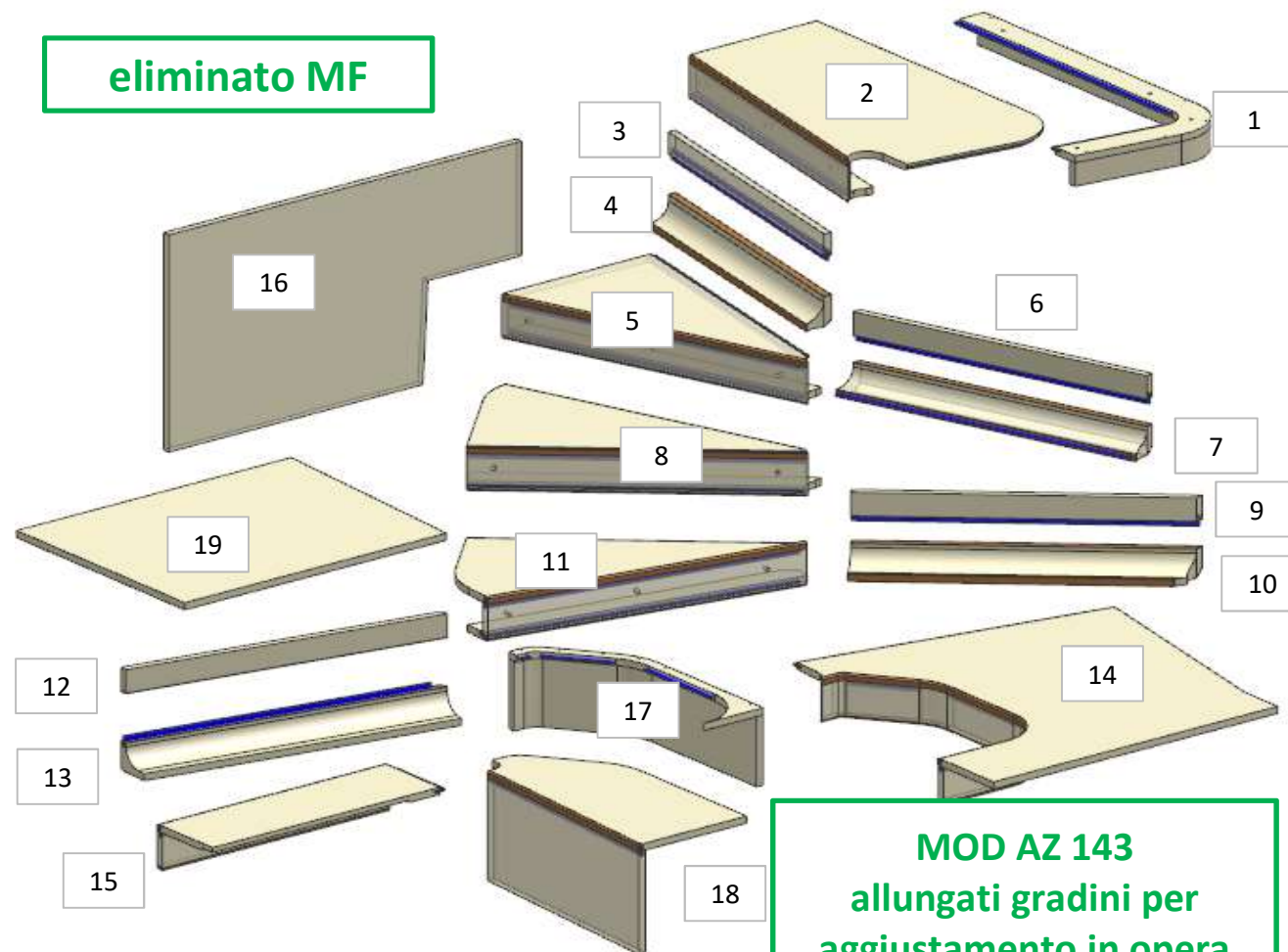

- 1 - sviluppo L 1074 x H.69 x 60
- 2 - L. 786 x H.100 x 435
- 3 - L. 687 x H.50 x sp 16
- 4 - L. 679 x H.70 x 57

- 5 - L. 716 x H.100 x 358
- 6 - L. 707 x H.54 x sp 16
- 7 - L. 719 x H.66 x 57
- 8 - L. 712 x H.100 x 371
- 9 - L. 712 x H.54 x sp 16
- 10 - L. 717 x H.66 x 66
- 11 - L. 735 x H.100 x 312
- 12 - L. 730 x H.54 x sp 16
- 13 - L. 730 x H.66 x 75
- 14 - L. 642 x H.100 x 703
- 15 - L. 542 x H.100 x 168
- 16 - L. 843 x H.488 x sp 16
- 17 - sviluppo L 627 x H.174 x 208
- 18 - L. 540 x H 246 x 257
- 19 - L. 657 x H.535 x sp 16

MOD AZ 143
allungati gradini per
aggiustamento in opera

AZ26M

MOD GR4

REV. GR 9

LOCALE	CODICE	DESCRIZIONE COMPONENTE	FINITURA	Q.TA	OPERATORE
TIMONERIA	AZ26M-R01_TY01	RIV. GRADINI DISCESA ARMATORE	LASTRA CHIARA	13	Damiano

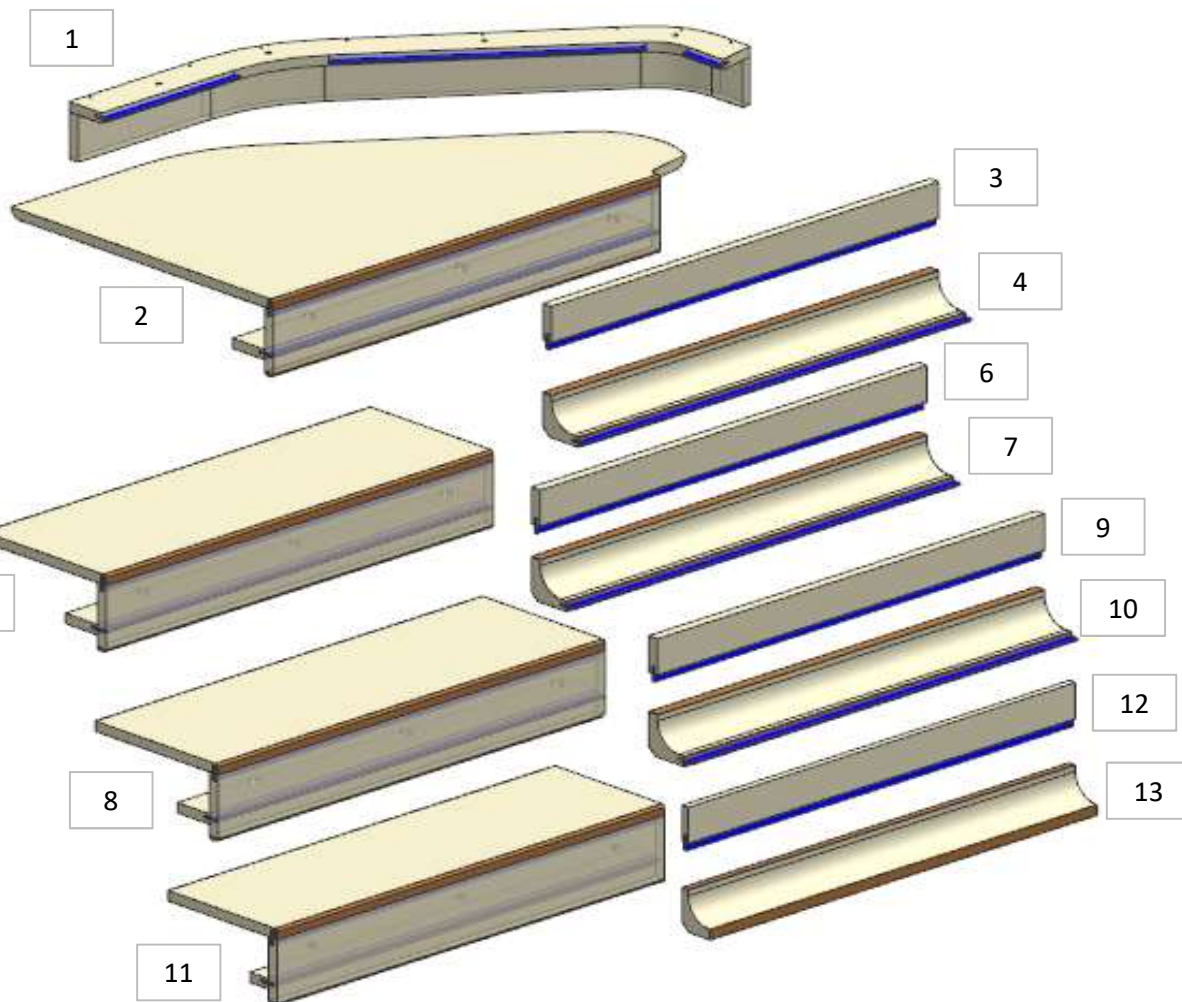

- 1 - L 937 x H 89 x 258
- 2 - L 806 x H 120 x 490
- 3 - 6 - 9 - 12 - L 739 x H 57 x sp 16
- 4 - 7 - 10 - L 739 x H 66 x 66
- 5 - 8 - 11 - L 739 x H 120 x 228
- 13 - L 739 x H 66 x 52

MOD AZ 144
allungati gradini per
aggiustamento in opera

eliminato MF