

AZ26M

MOD DA GR4

REV. GR 9

LOCALE	CODICE	DESCRIZIONE COMPONENTE	FINITURA	Q.TA	OPERATORE
SALONE	AZ26M-R01_SA01	STRUTTURA MURATA DX PRUA	LASTRA CHIARA	8	Damiano

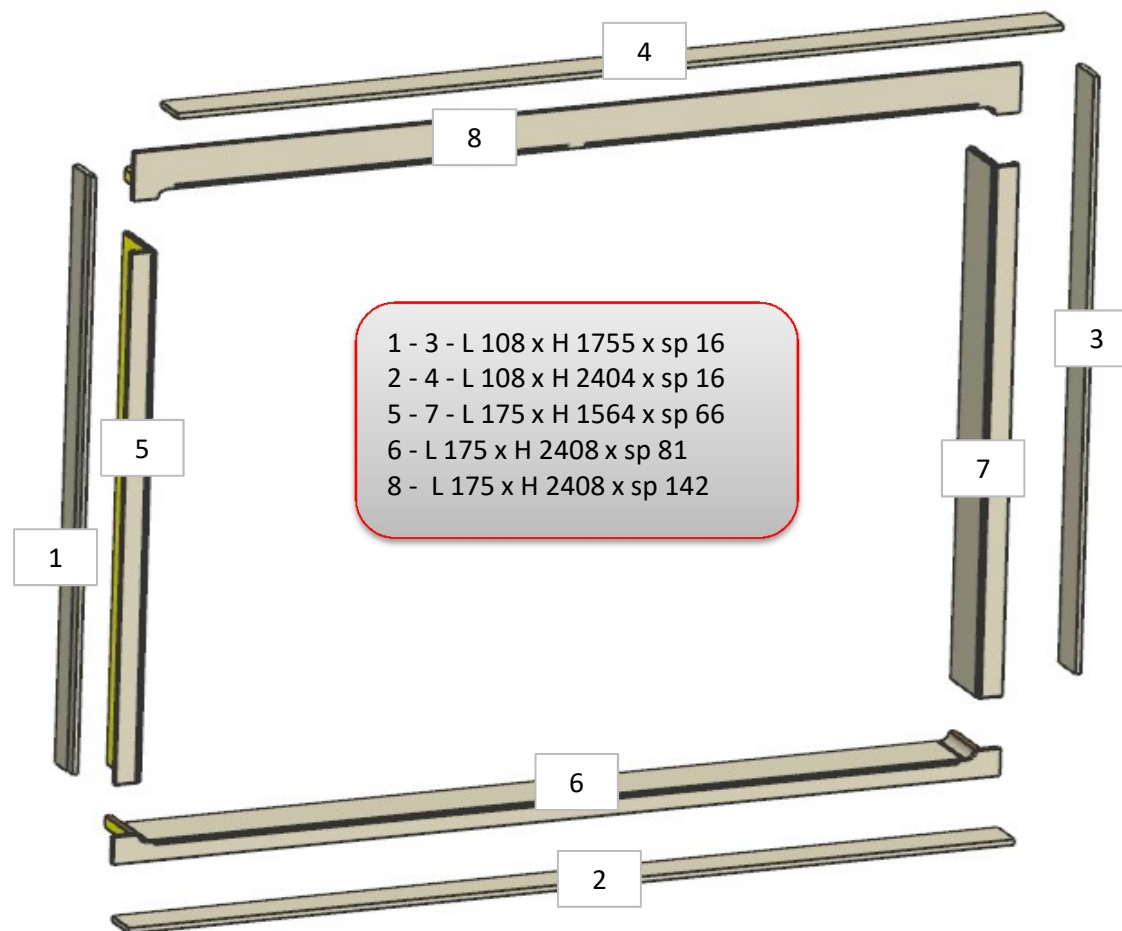

AZ26M

MOD DA GR4

REV. GR 9

LOCALE	CODICE	DESCRIZIONE COMPONENTE	FINITURA	Q.TA	OPERATORE
SALONE	AZ26M-R01_SD01	STRUTTURA MURATA DX POPPA	LASTRA CHIARA	8	Damiano

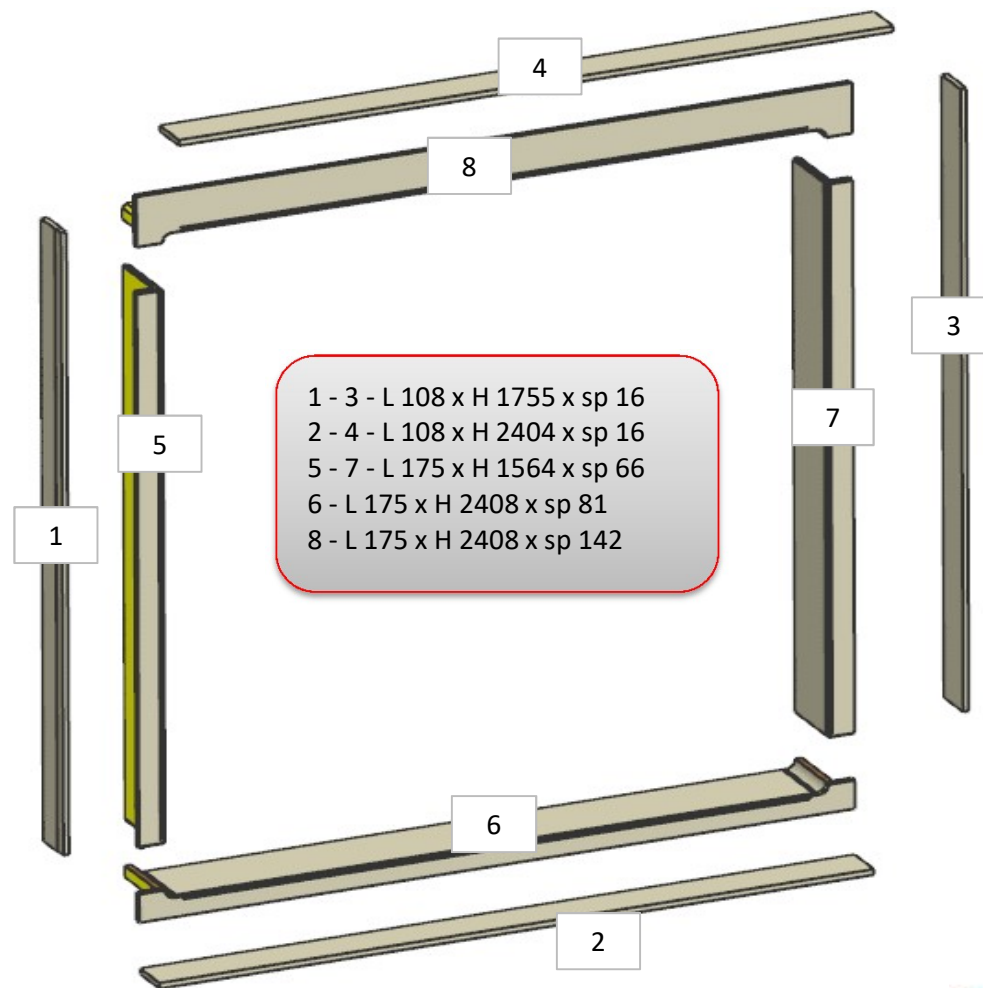

AZ26M

MOD DA GR4

REV. GR 9

LOCALE	CODICE	DESCRIZIONE COMPONENTE	FINITURA	Q.TA	OPERATORE
SALONE	AZ26M-R01_SF01	STRUTTURA MURATA SX PRUA	LASTRA CHIARA	8	Damiano

- 1 - 3 - L 108 x H 1755 x sp 16
- 2 - 4 - L 108 x H 1832 x sp 16
- 5 - 7 - L 190 x H 1564 x sp 66
- 6 - L 190 x H 1836 x sp 81
- 8 - L 190 x H 1836 x sp 142

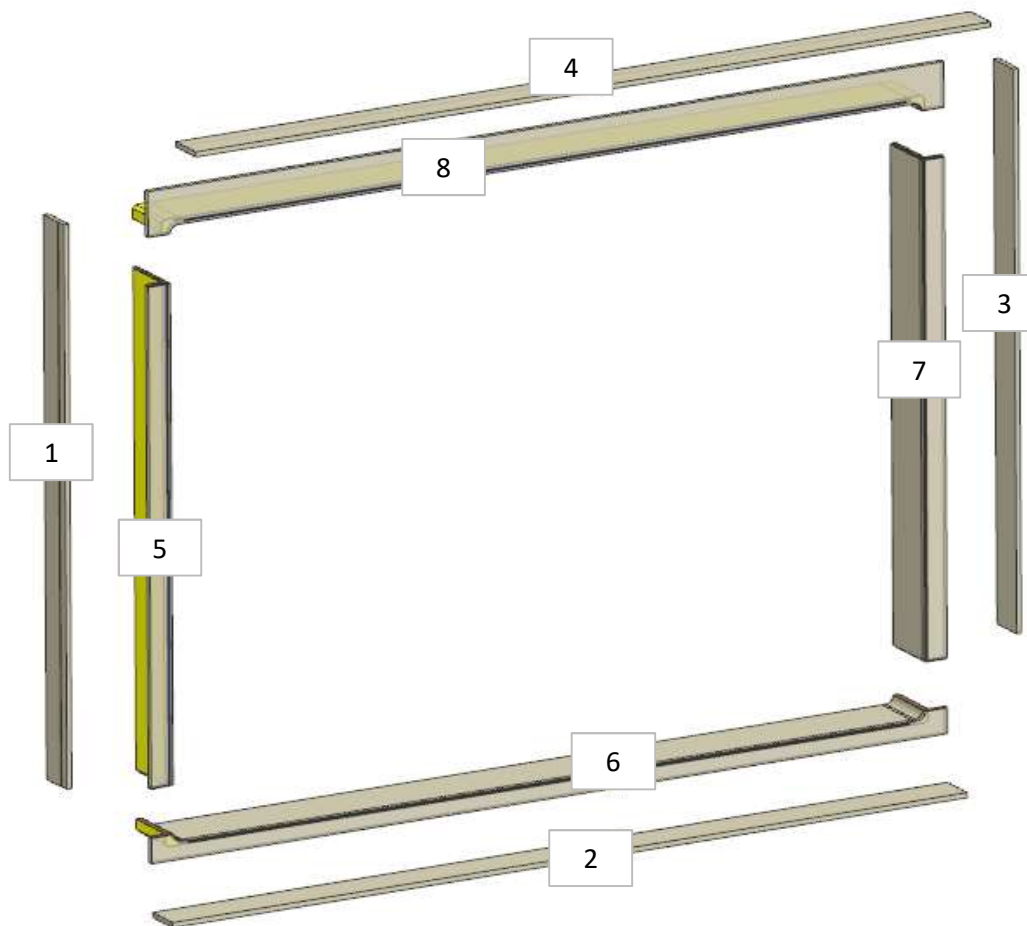

AZ26M

MOD DA GR4

REV. GR 9

LOCALE	CODICE	DESCRIZIONE COMPONENTE	FINITURA	Q.TA	OPERATORE
SALONE	AZ26M-R01_SI01	STRUTTURA MURATA SX POPPA	LASTRA CHIARA	10	Damiano

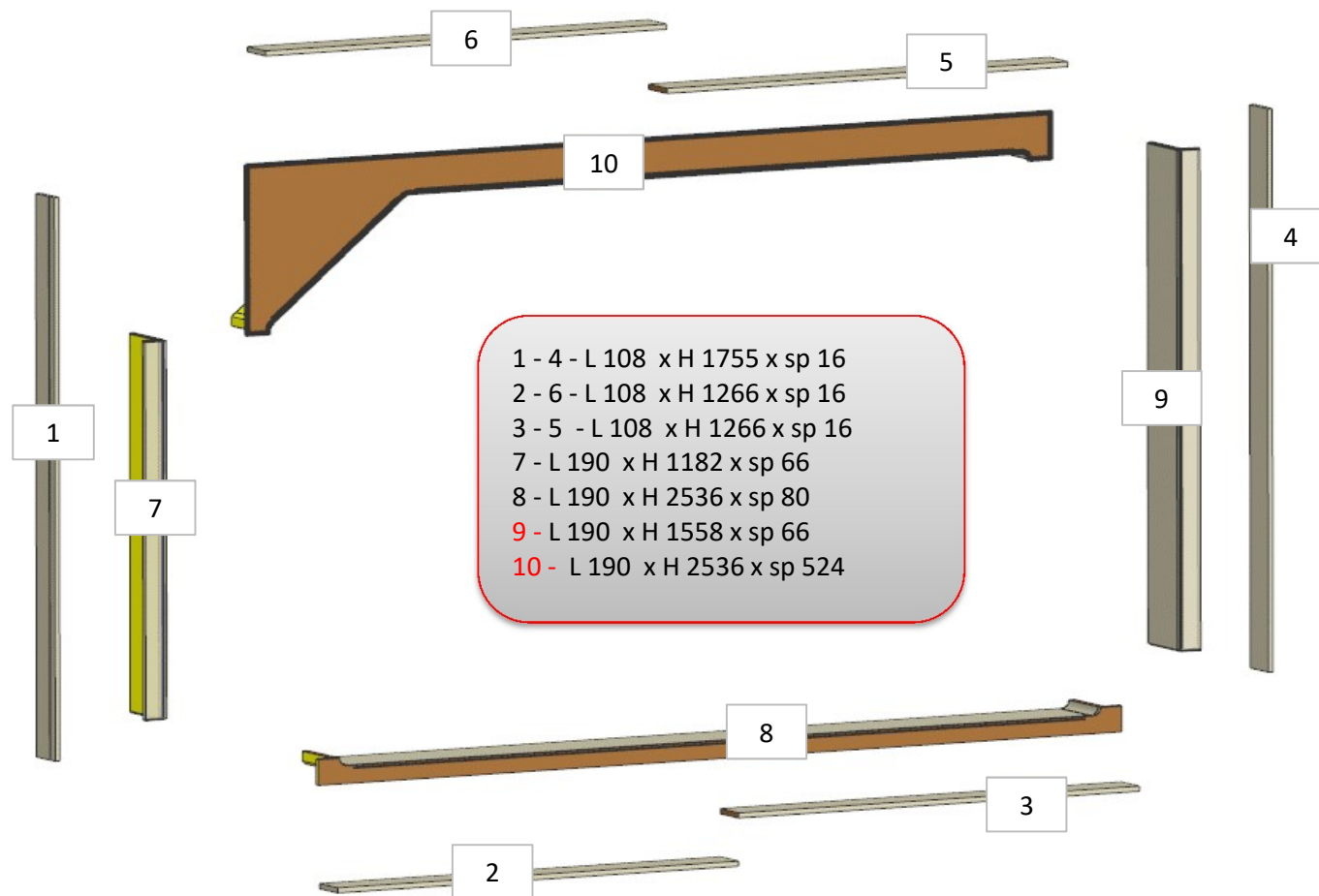

AZ26M

MOD DA PTP

REV. GR 9

LOCALE	CODICE	DESCRIZIONE COMPONENTE	FINITURA	Q.TA	OPERATORE
SALONE	AZ26M-R01_SJ01	TAVOLO SALONE	LASTRA CHIARA	5	Damiano

MOD INT 38
 MODIFICATI CODICI
 LASTRA 02-03-04-05 E
 MODIFICATO PIASTRE

- 1 - L 2550 x H.950 x sp 32
- 2 - 3 - L 450 x H.695 x sp 77
- 4 - 5 - L 519 x H.695 x sp 77

MOD INT 38
 n°5 pz DA R01_SJ01_01
 DIVENTATI LACCATI

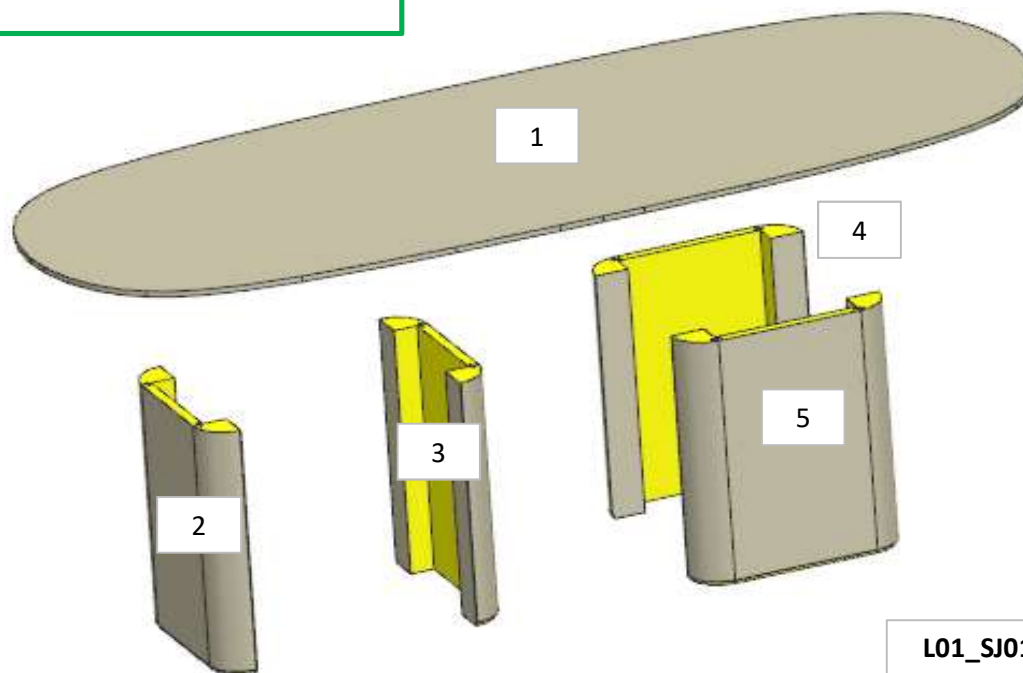

ELEMENTO DA MONTARE con:
L01_SJ01
 e spedire con un unico imballo

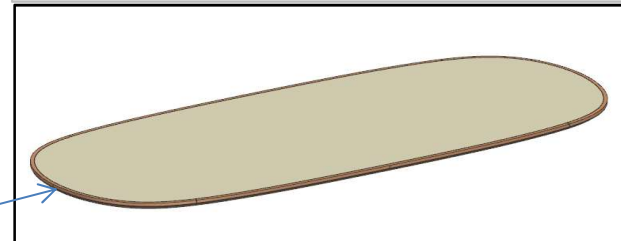

L01_SJ01

AZ26M

MOD DA GR4

REV. GR 9

LOCALE	CODICE	DESCRIZIONE COMPONENTE	FINITURA	Q.TA	OPERATORE
SALONE	AZ26M-R01_SM01	MOBILE COLONNA SX POPPA	LASTRA CHIARA	6	Damiano

- 1 - L 581 x H.2036 x sp 25
- 2 - L 121 x H.430 x sp 19
- 3 - L 427 x H. 232 x sp 25
- 4 - L 427 x H. 1310 x sp 25
- 5 - L 427 x H. 490 x sp 25
- 6 - L 430 x H. 1628 x 91

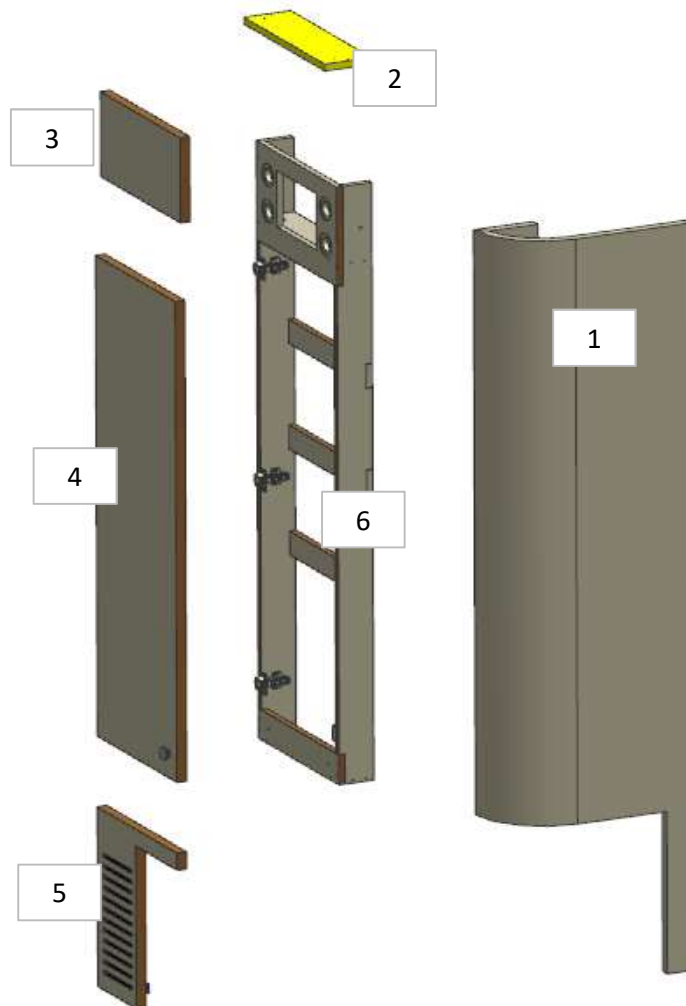

MOD AZ 161
modificato mobile per
aumentare lo storage

AZ26M

REV. 01-2023

REV. GR 9

LOCALE	CODICE	DESCRIZIONE COMPONENTE	FINITURA	Q.TA	OPERATORE
SALONE	AZ26M-R01_SO01	COMODINO SX CENTRONAVE	LASTRA CHIARA	2	Damiano

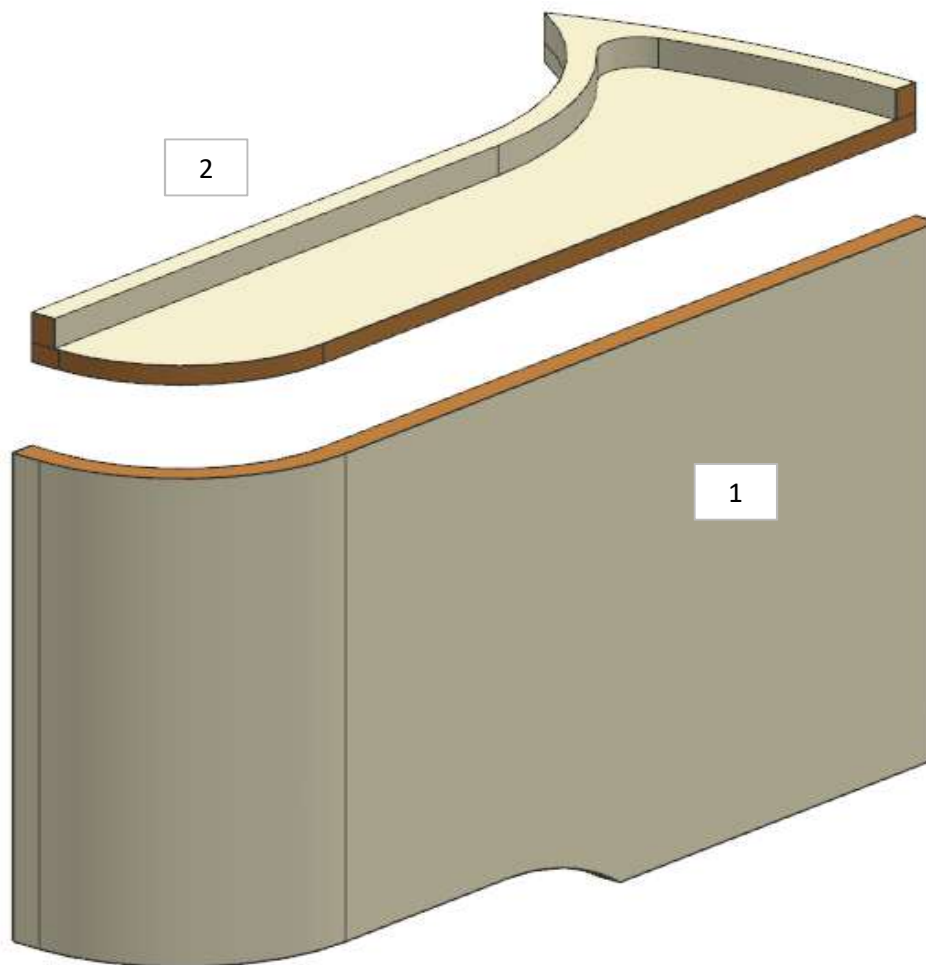

- 1 - SVILUPPO L 885 x H 445 x sp 20
- 2 - SVILUPPO L 854 x H.290 x sp 41

AZ26M

REV. 01-2023

REV. GR 9

LOCALE	CODICE	DESCRIZIONE COMPONENTE	FINITURA	Q.TA	OPERATORE
SALONE	AZ26M-R01_SP01	STRUTTURA INGRESSO DX POPPA	LASTRA CHIARA	5	Damiano

- 1 - L 633 x H 1275 x sp 16
- 2 - L 474 x H.418 x sp 36
- 3 - L 221 x H 2036 x sp 20
- 4 - L 473 x H 1169 x sp 25
- 5 - L 472 x H 445 x sp 36

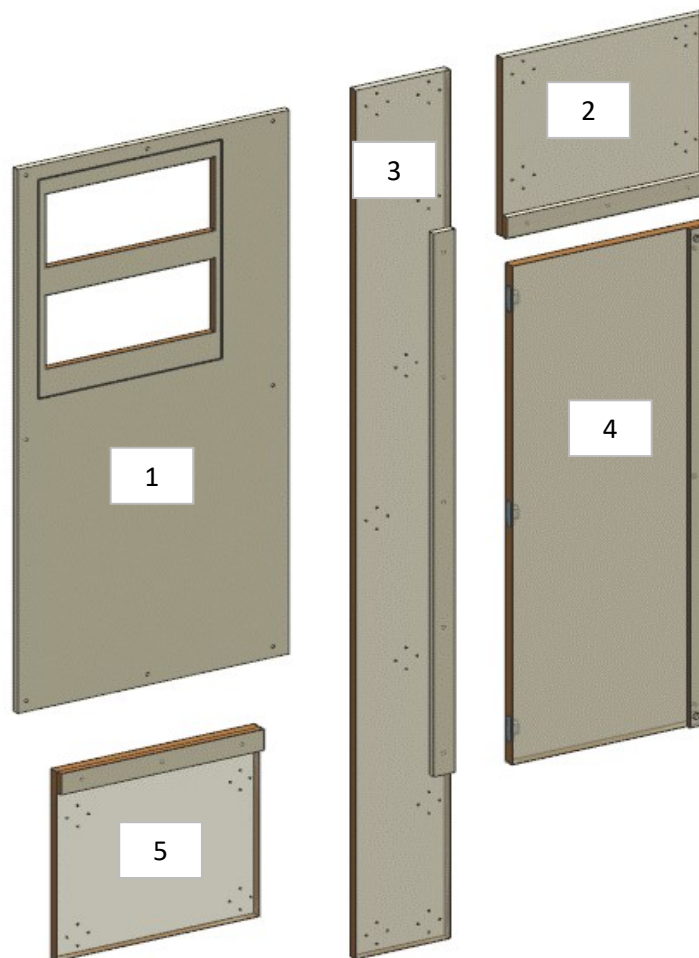

AZ26M

MOD DA GR4

REV. GR 9

LOCALE	CODICE	DESCRIZIONE COMPONENTE	FINITURA	Q.TA	OPERATORE
SALONE	AZ26M-R01_SQ01	MOBILE IN NICCHIA DX POPPA	LASTRA CHIARA	10	Damiano

- 1 - L 372 x H 2036 x sp 20
- 2 - L 467 x H.401 x sp 20
- 3 - L 215 x H 75 x sp 215
- 4 - L 472 x H 2036 x sp 20
- 5 - L 491 x H 485 x sp 16
- 6 - L 431 x H 455 x sp 16
- 7 - L 465 x H 213 x sp 45
- 8 - L 346 x H 41 x sp 16
- 9 - L 465 x H 213 x sp 45
- 10 - L 346 x H 76 x sp 32

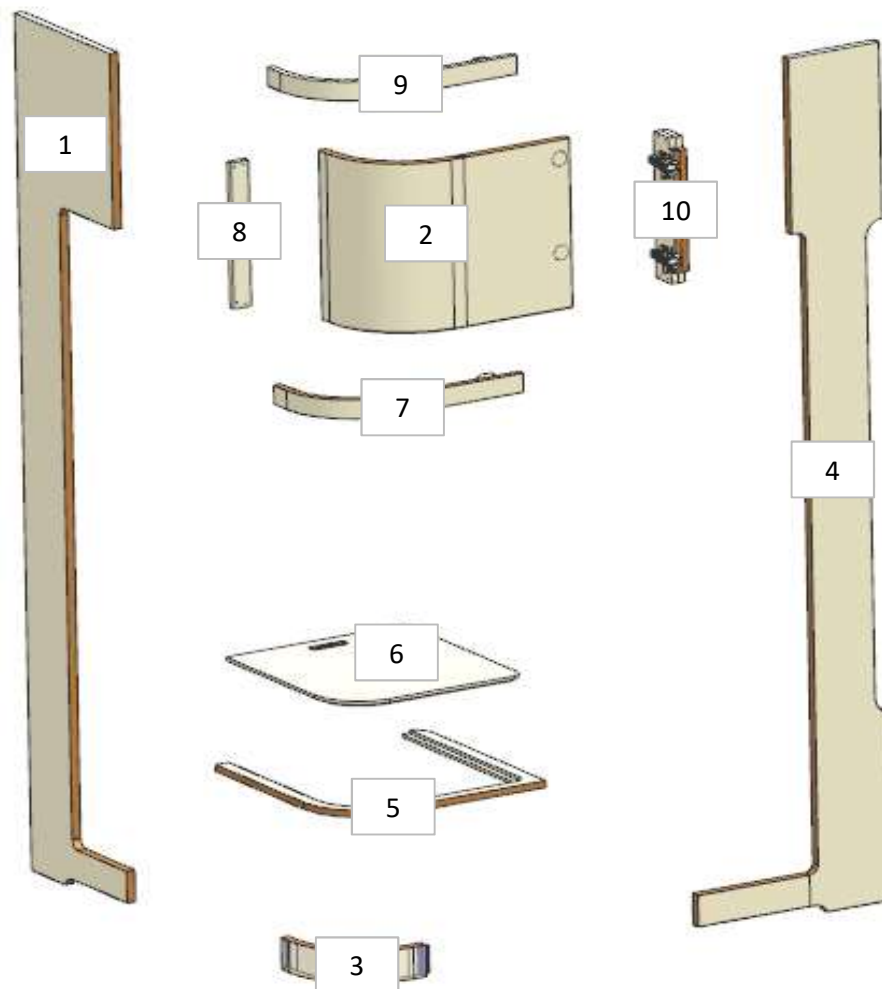

MOD AZ 155
reso apribile
cappello per
aumento storage

AZ26M

REV. 01-2023

REV. GR 9

LOCALE	CODICE	DESCRIZIONE COMPONENTE	FINITURA	Q.TA	OPERATORE
SALONE	AZ26M-R01_SR01	MOBILE SUBWOOFER SX POPPA	LASTRA CHIARA	10	Damiano

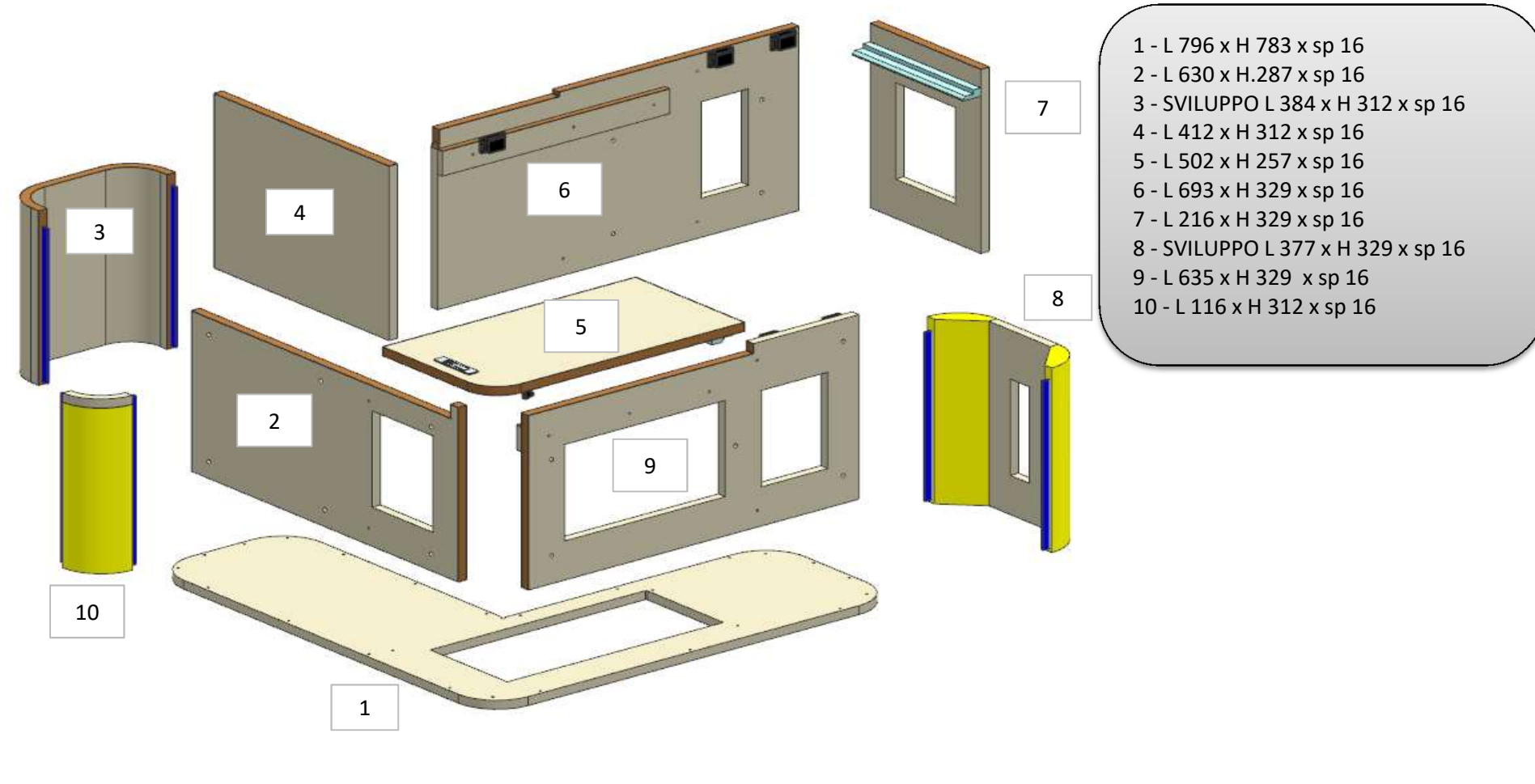

- 1 - L 796 x H 783 x sp 16
- 2 - L 630 x H.287 x sp 16
- 3 - SVILUPPO L 384 x H 312 x sp 16
- 4 - L 412 x H 312 x sp 16
- 5 - L 502 x H 257 x sp 16
- 6 - L 693 x H 329 x sp 16
- 7 - L 216 x H 329 x sp 16
- 8 - SVILUPPO L 377 x H 329 x sp 16
- 9 - L 635 x H 329 x sp 16
- 10 - L 116 x H 312 x sp 16

AZ26M

REV. 01-2023

REV. GR 9

LOCALE	CODICE	DESCRIZIONE COMPONENTE	FINITURA	Q.TA	OPERATORE
SALONE	AZ26M-R01_SW01	RIV. PARETE PASSAVIVANDE	LASTRA CHIARA	5	Damiano

- 1 - L 1480 x H 2025 x sp 11
- 2 - 4 - L 850 x H.68 x sp 11
- 3 - L 115 x H.408 x sp 62
- 5 - L 68 x H.408 x sp 11

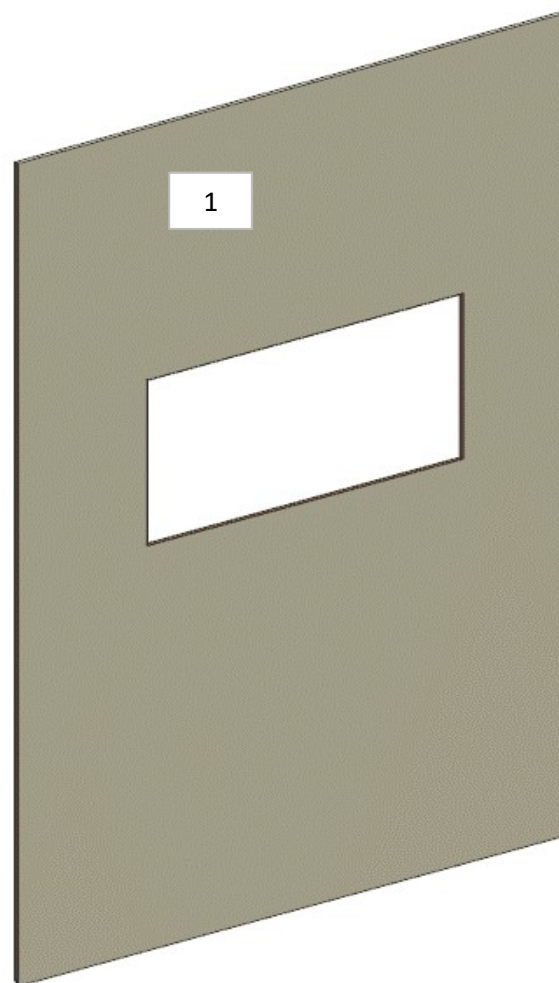
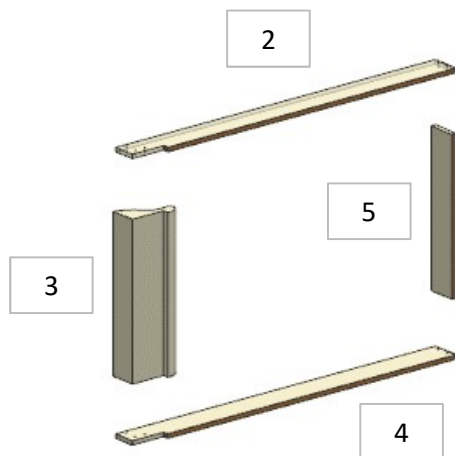

FERRAMENTA:

- ML 2,7 - PIATTINA ANGOLARE PREFORATA sp 1mm
- ML 4 - PIATTINE IN ACCIAIO PREFORATO sp 1mm

AZ26M

REV. GR 9

LOCALE	CODICE	DESCRIZIONE COMPONENTE	FINITURA	Q.TA	OPERATORE
SALONE	AZ26M-R01_SZ01	PORTA SCORREVOLE SALONE	LASTRA CHIARA	1	Damiano

**VERIFICARE LATO
FRONTALE E MASSELLI
CHE LA VENA SIA A 45°
E SUL RETRO IN
VERTICALE**

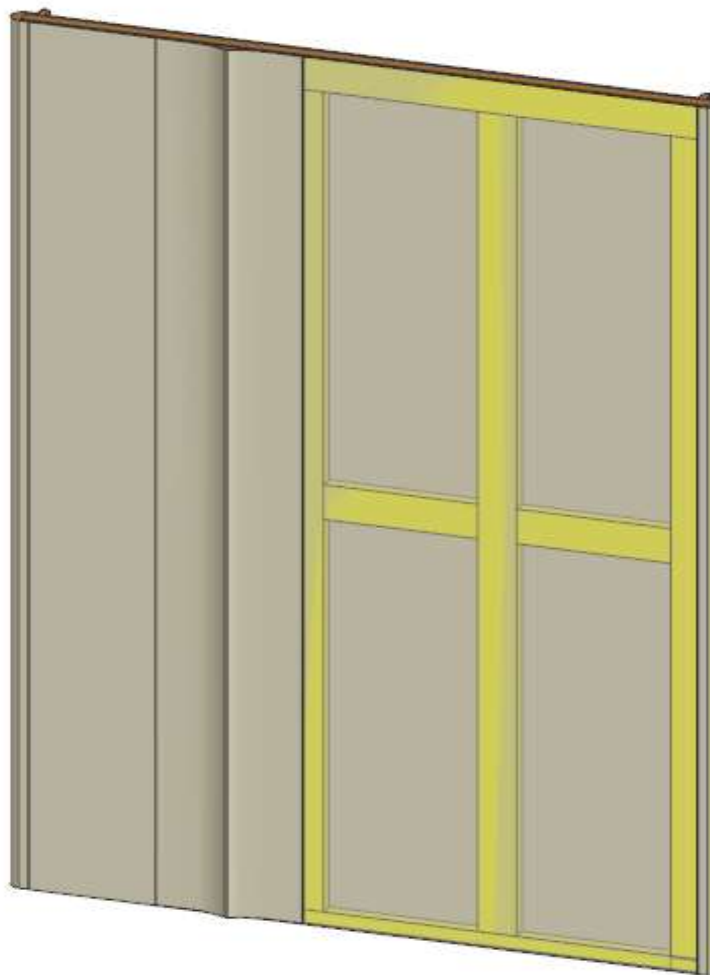

consonni&c