

AZ26M

REV. 01-2023

REV. GR 9

LOCALE	CODICE	DESCRIZIONE COMPONENTE	FINITURA	Q.TA	OPERATORE
LOBBY MD	AZ26M-R01_CCA01	STRUT. LATO SX MOBILE RACK	LASTRA CHIARA	1	Damiano

1 - L 2249 x H.343 x sp 16



AZ26M

REV. 01-2023

REV. GR 9

LOCALE	CODICE	DESCRIZIONE COMPONENTE	FINITURA	Q.TA	OPERATORE
LOBBY MD	AZ26M-R01_CCB01	ZOCCOLO MOBILE RACK	LASTRA CHIARA	1	Damiano

1 - L 1138 x H.325 x sp 22

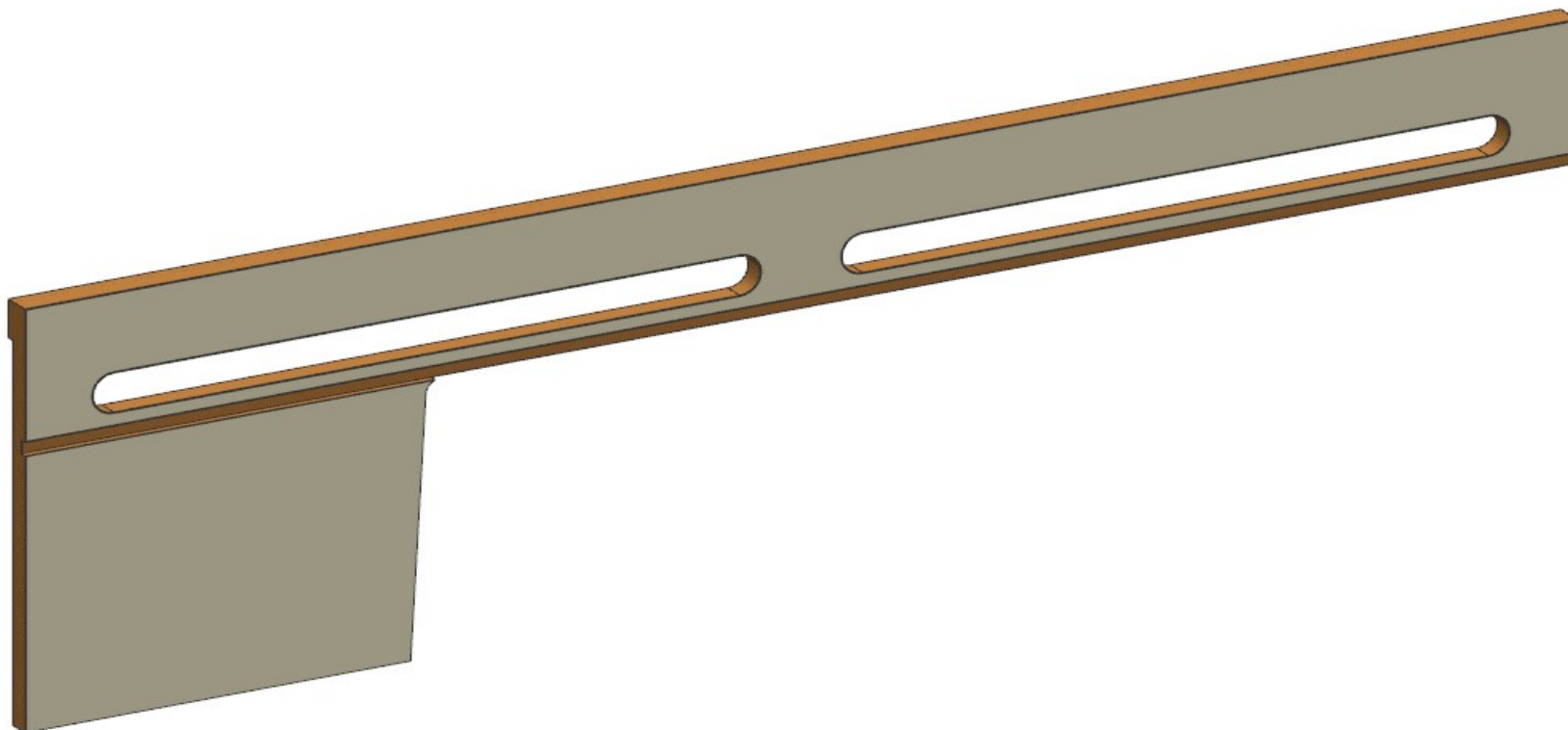

AZ26M

REV. 01-2023

REV. GR 9

LOCALE	CODICE	DESCRIZIONE COMPONENTE	FINITURA	Q.TA	OPERATORE
LOBBY MD	AZ26M-R01_CCC01	MOBILE RACK	LASTRA CHIARA	3	Damiano



1 - 3 - L 633 x H.1235 x sp 20
2 - L 100 x H.1238 x 67

AZ26M

MOD DA GR9

REV. GR 9

LOCALE	CODICE	DESCRIZIONE COMPONENTE	FINITURA	Q.TA	OPERATORE
LOBBY MD	AZ26M-R01_CCD01	STRUTTURA SUPERIORE MOBILE RACK	LASTRA CHIARA	1	Damiano

1 - L 1138 x H 684 x sp 16

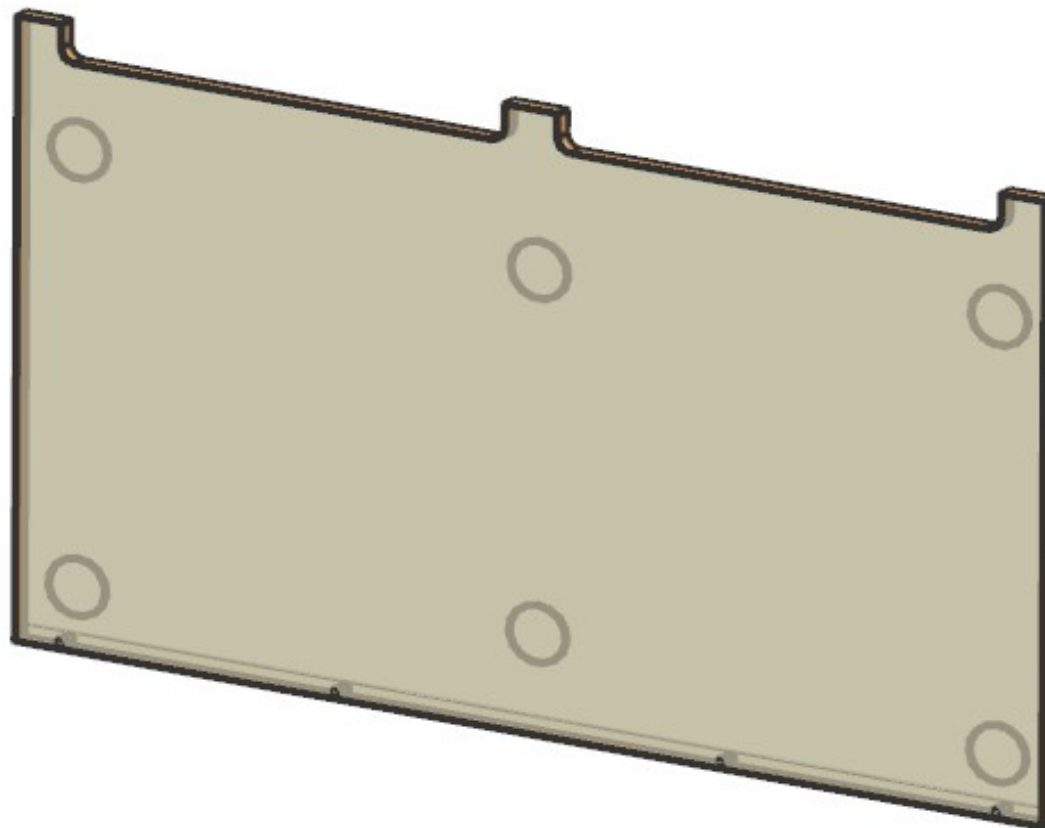

MOD AZ 264
FATTO ASOLATURA SUL
PANNELLO IN ESSENZ PER
EVITARE
SURRISCALDAMENTO AV

AZ26M

REV. 01-2023

REV. GR 9

LOCALE	CODICE	DESCRIZIONE COMPONENTE	FINITURA	Q.TA	OPERATORE
LOBBY MD	AZ26M-R01_CCE01	STRUT. LATO DX MOBILE RACK	LASTRA CHIARA	1	Damiano

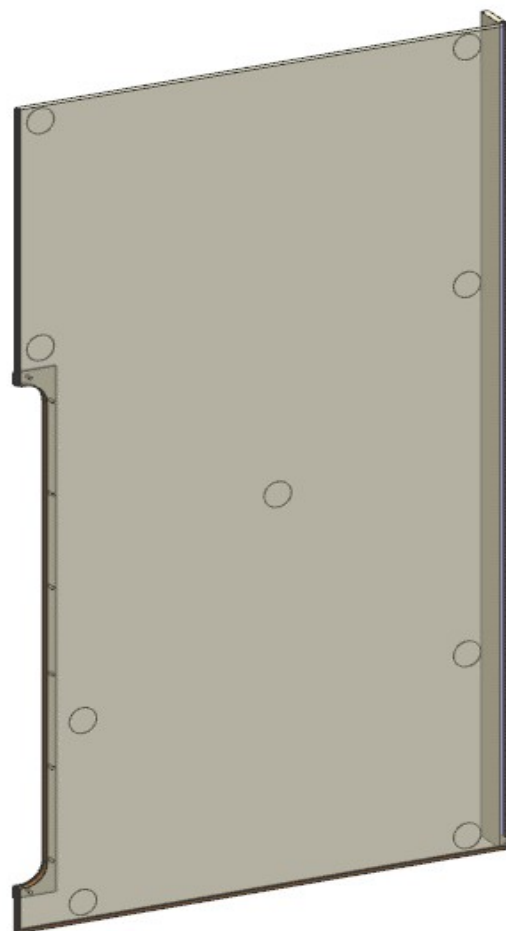

AZ26M

REV. 01-2023

REV. GR 9

LOCALE	CODICE	DESCRIZIONE COMPONENTE	FINITURA	Q.TA	OPERATORE
LOBBY MD	AZ26M-R01_CCF01	MOBILEE WIN COOLER	LASTRA CHIARA	5	Damiano

- 1 - L 702 x H 2026 x sp 11
- 2 - L 605 x H 2036 x sp 41
- 3 - L 528 x H 1090 x sp 25
- 4 - L 528 x H 735 x sp 25
- 5 - L 97 x H 2036 x 86

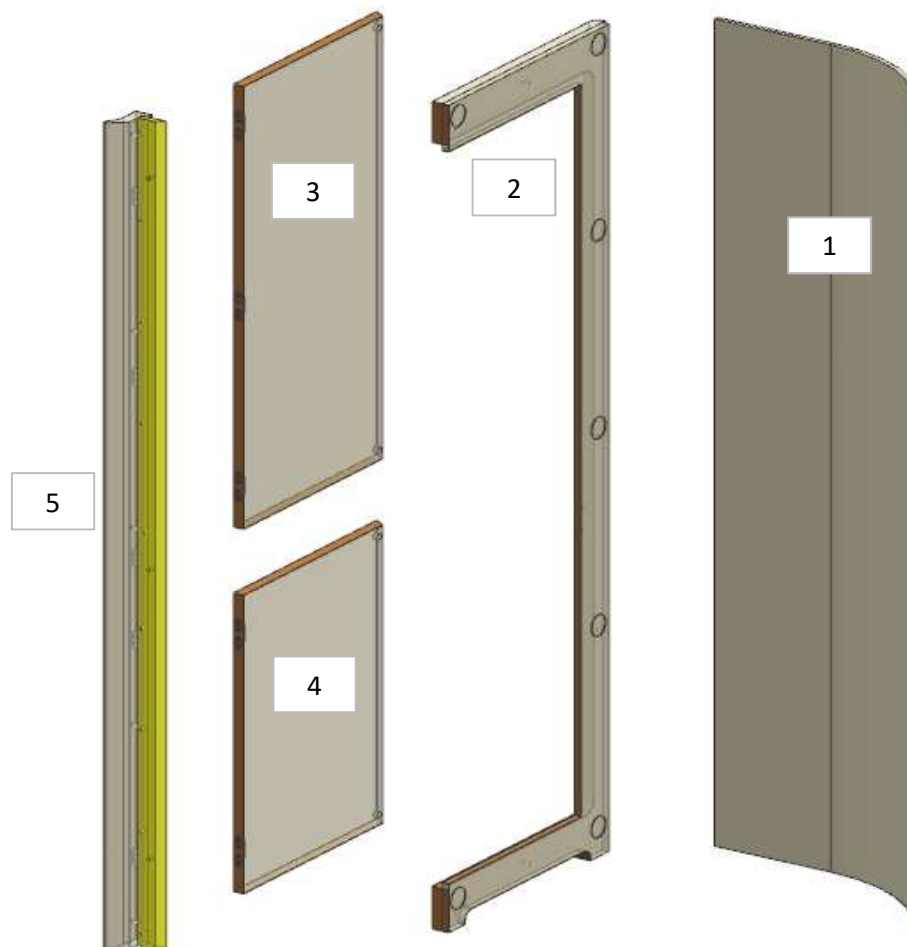

AZ26M

REV. GR 9

LOCALE	CODICE	DESCRIZIONE COMPONENTE	FINITURA	Q.TA	OPERATORE
LOBBY MD	AZ26M-R01_CCG01	CIELINO	LASTRA CHIARA	1	Damiano

1 - L 1088 x H 629 x sp 11

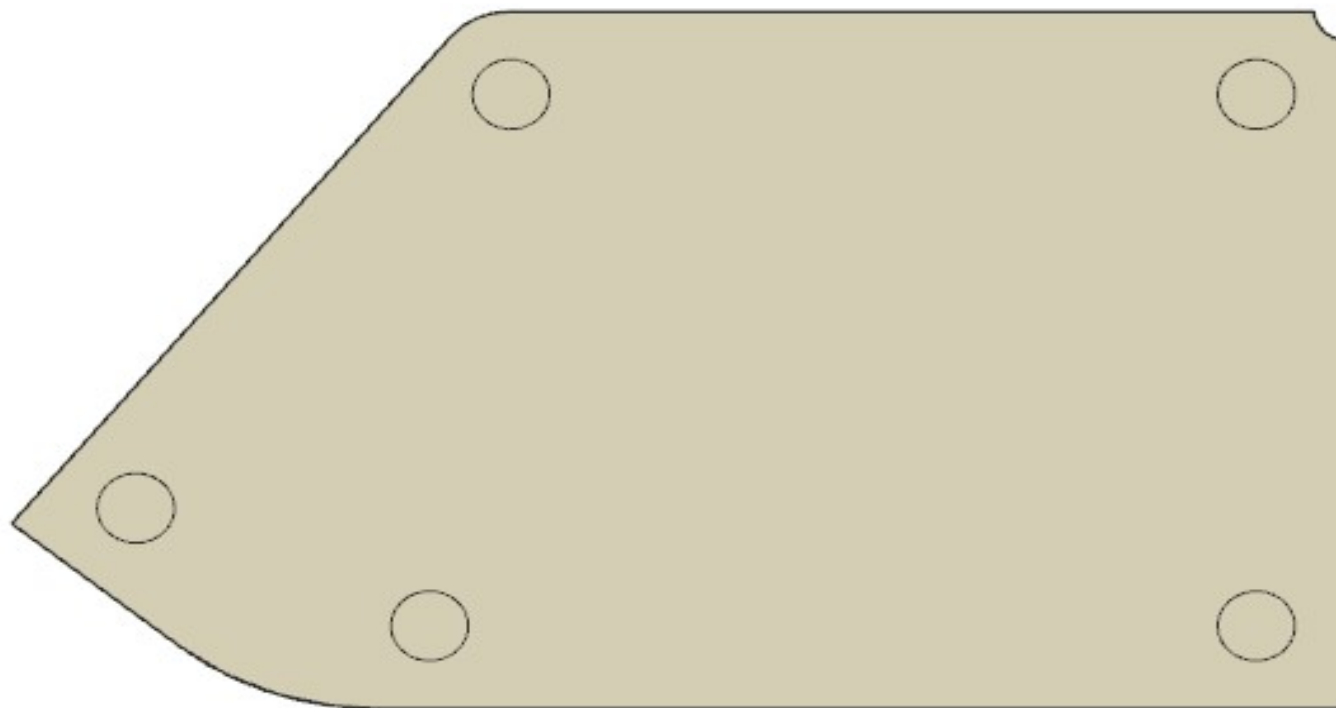

AZ26M

REV. GR 9

LOCALE	CODICE	DESCRIZIONE COMPONENTE	FINITURA	Q.TA	OPERATORE
LOBBY MD	AZ26M-R01_CCH01	GRADINO	LASTRA CHIARA	1	Damiano

1 - L 1147 x H 171 x sp 6

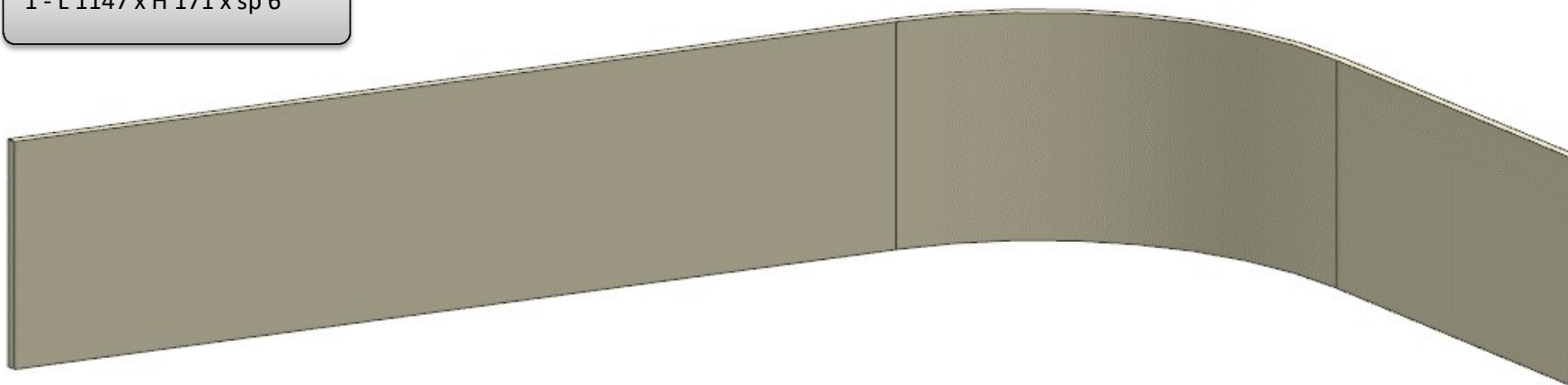

ELEMENTO DA MONTARE con:
CCH01
L01_CCH01
e spedire con un unico imballo

L01_CCH01

CCH01

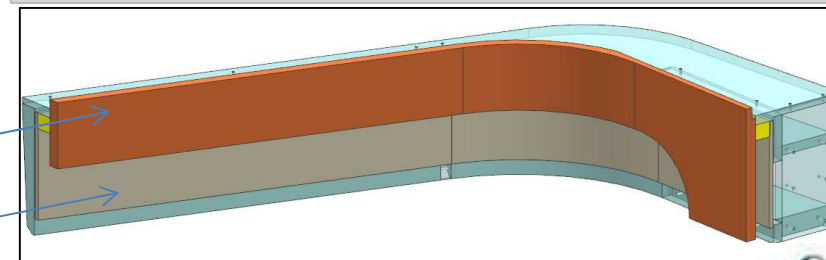

consonni&c

AZ26M

REV. GR 9

LOCALE	CODICE	DESCRIZIONE COMPONENTE	FINITURA	Q.TA	OPERATORE
LOBBY MD	AZ26M-R01_CCI01	DISCESA SCALE LATO ARMATORE	LASTRA CHIARA	2	Damiano

- 1 - L 2036 x H 67 x sp 11
- 2 - L 2036 x H 449 x sp 11

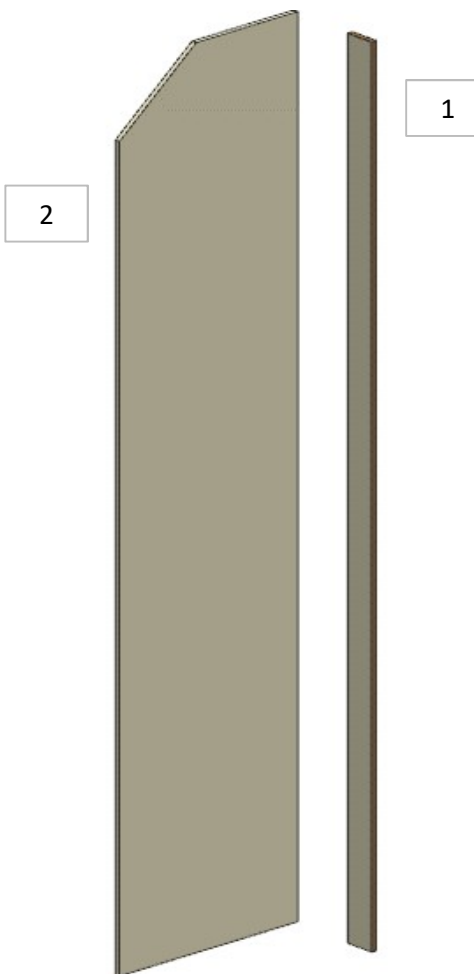

AZ26M

REV. GR 9

LOCALE	CODICE	DESCRIZIONE COMPONENTE	FINITURA	Q.TA	OPERATORE
LOBBY MD	AZ26M-R01_CCL01	RIV. SOPRA PORTA	LASTRA CHIARA	1	Damiano

1 - L 698 x H 78 x sp 11

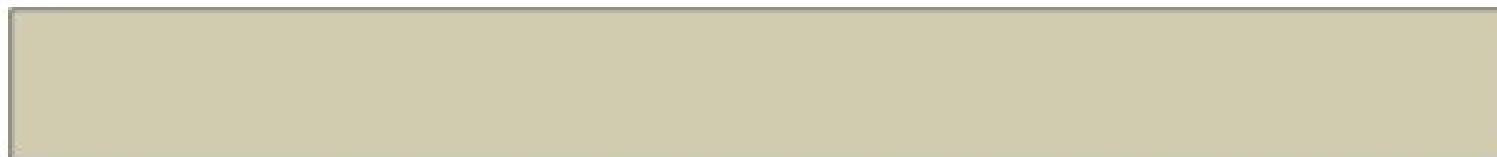

AZ26M

REV. GR 9

LOCALE	CODICE	DESCRIZIONE COMPONENTE	FINITURA	Q.TA	OPERATORE
LOBBY MD	AZ26M-R01_CCM01	RIV. GRADINO POSTA SCORREVOLE	LASTRA CHIARA	1	Damiano

1 - L 903 x H 226 x 44

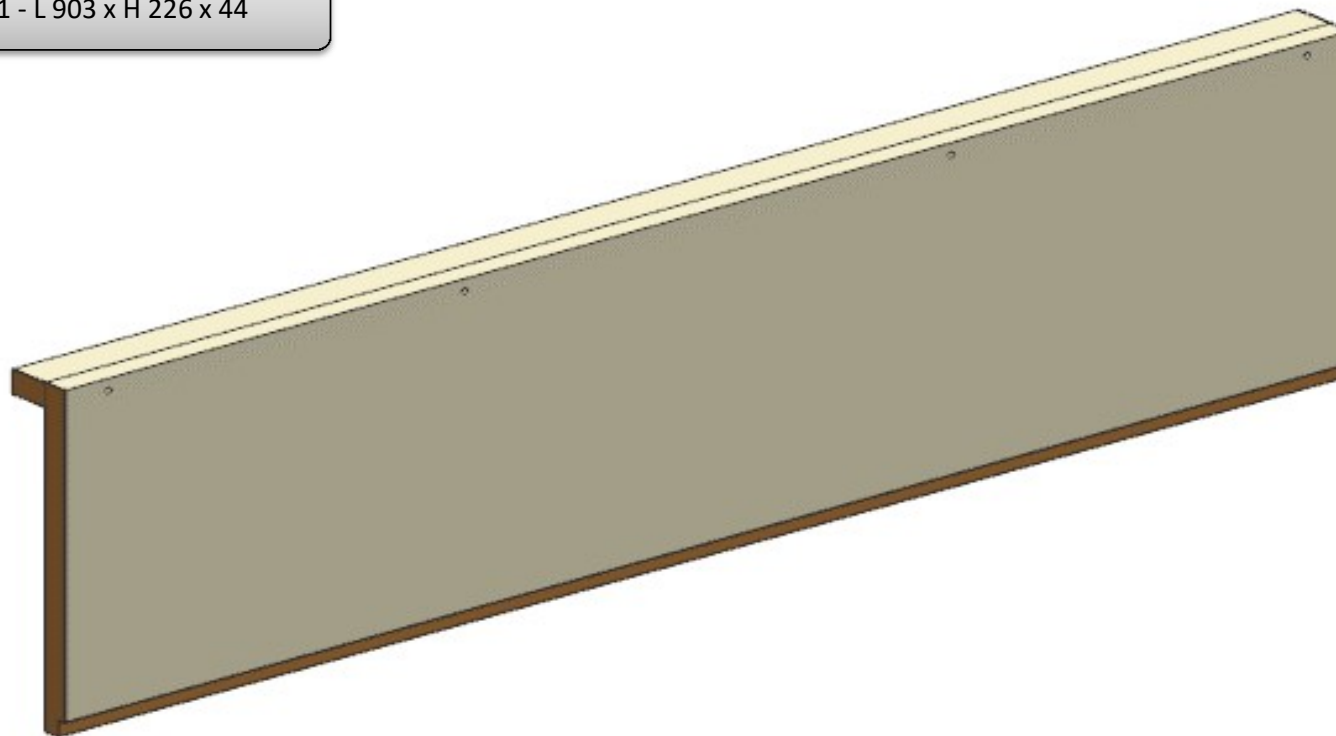

SEZIONE



consonni&c

AZ26M

REV. GR 9

LOCALE	CODICE	DESCRIZIONE COMPONENTE	FINITURA	Q.TA	OPERATORE
LOBBY MD	AZ26M-R01_CCN01	STRUTTURA RIV. DI POPPA PORTA SCORREVOLE	LASTRA CHIARA	3	Damiano

- 1 - L 62 x H 2025 x sp 16
- 2 - L77x H 2036 x 77
- 3 - L 639 x H 2036 x 122



AZ26M

MOD DA GR10

REV. GR 10

LOCALE	CODICE	DESCRIZIONE COMPONENTE	FINITURA	Q.TA	OPERATORE
LOBBY MD	AZ26M-R01_CCO01	RIV. PARATIA IMPIANTI DAY TOILET	LASTRA CHIARA	3	Damiano

- 1 - sviluppo L 160 x H 2051 x sp 110
- 2 - sviluppo L 696 x H 2051 x sp 11
- 3 - sviluppo L 70 x H 2051 x sp 50

MOD INTERNA 45
DIVENTATO IN 3 PEZZI
DA GR10

