

AZ26M

REV. 01-2023

REV. GR 9

LOCALE	CODICE	DESCRIZIONE COMPONENTE	FINITURA	Q.TA	OPERATORE
CABINA ARMATORE	AZ26M-R01_AA01	ARMADIO INGRESSO DX POPPA	LASTRA CHIARA	6	Damiano

MOD PTP
MODIFICA CODIFICA

ATTENZIONE:
SPINARE MA NON
INCOLLARE

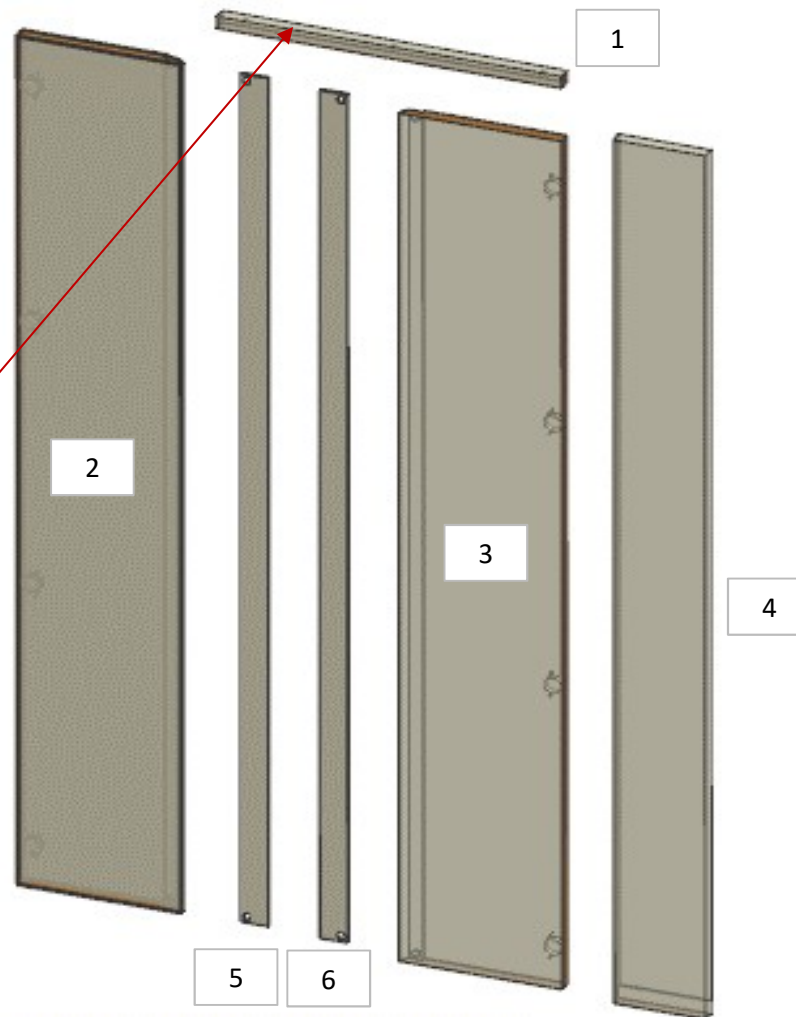

- 1 - L.659 x H.28 x sp 25
- 2 - 3 - L.314 x H.1963 x sp 25
- 4 - L.147 x H.1998 x sp 25
- 5 - 6 - L.53 x H.1963 x sp 6

ELEMENTO DA MONTARE con:
R01_AA01_02/05
R01_AA01_03/06
e spedire con un unico imballo

MG_AC01

MG_AC02

consonni&c

AZ26M

MOD DA GR9

REV. GR 9

LOCALE	CODICE	DESCRIZIONE COMPONENTE	FINITURA	Q.TA	OPERATORE
CABINA ARMATORE	AZ26M-R01_AB01	ARMADIO INGRESSO SX POPPA	LASTRA CHIARA	11	Damiano

1 - 2 - L. 262 x H 1963 x sp 25
 3 - L. 73 x H 1968 x sp 25
 4 - L. 134 x H 1966 x sp 11
 5 - L. 516 x H 95 x sp 20

6 - L. 455 x H 26 x sp 41
 7 - 8 - L 53 x H 1963 x sp 6
 9 - L 352 x H 50 x sp 16
 10 - L 273 x 208 x 96

**MOD AZ 221
 REALIZZATO
 CONTROFFACCIATA
 IN LASTRA E
 MODIFICATO**

**ELEMENTO DA MONTARE con:
 MG_AB01
 MG_AB02
 e spedire con un unico imballo**

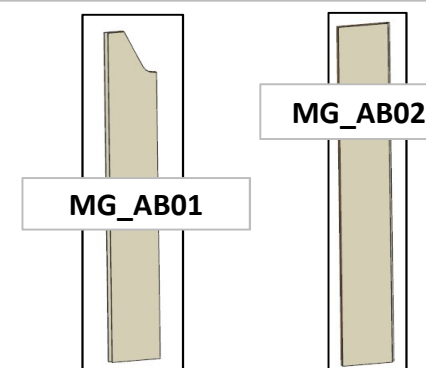
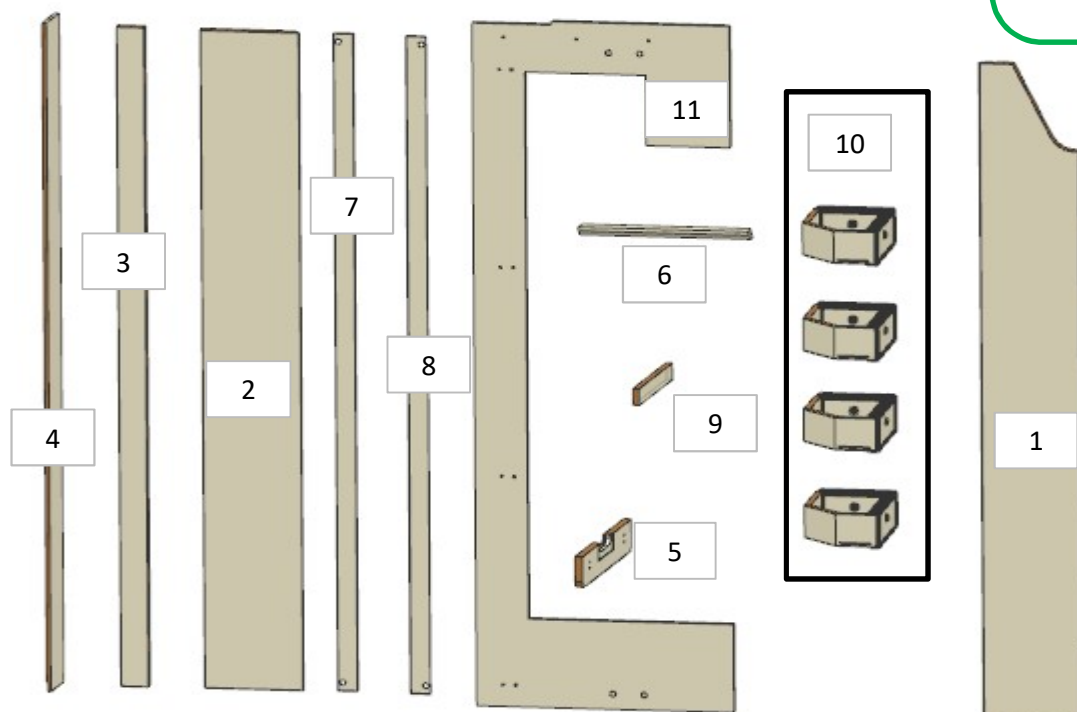

**ELEMENTO DA MONTARE con:
 L01_AB01
 e spedire con un unico imballo**

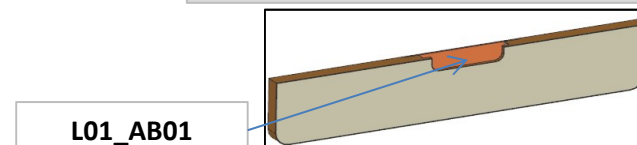

AZ26M

MOD GR5

REV. GR 9

LOCALE	CODICE	DESCRIZIONE COMPONENTE	FINITURA	Q.TA	OPERATORE
CABINA ARMATORE	AZ26M-R01_AC01	MURATA DX POPPA	LASTRA CHIARA	10	Damiano

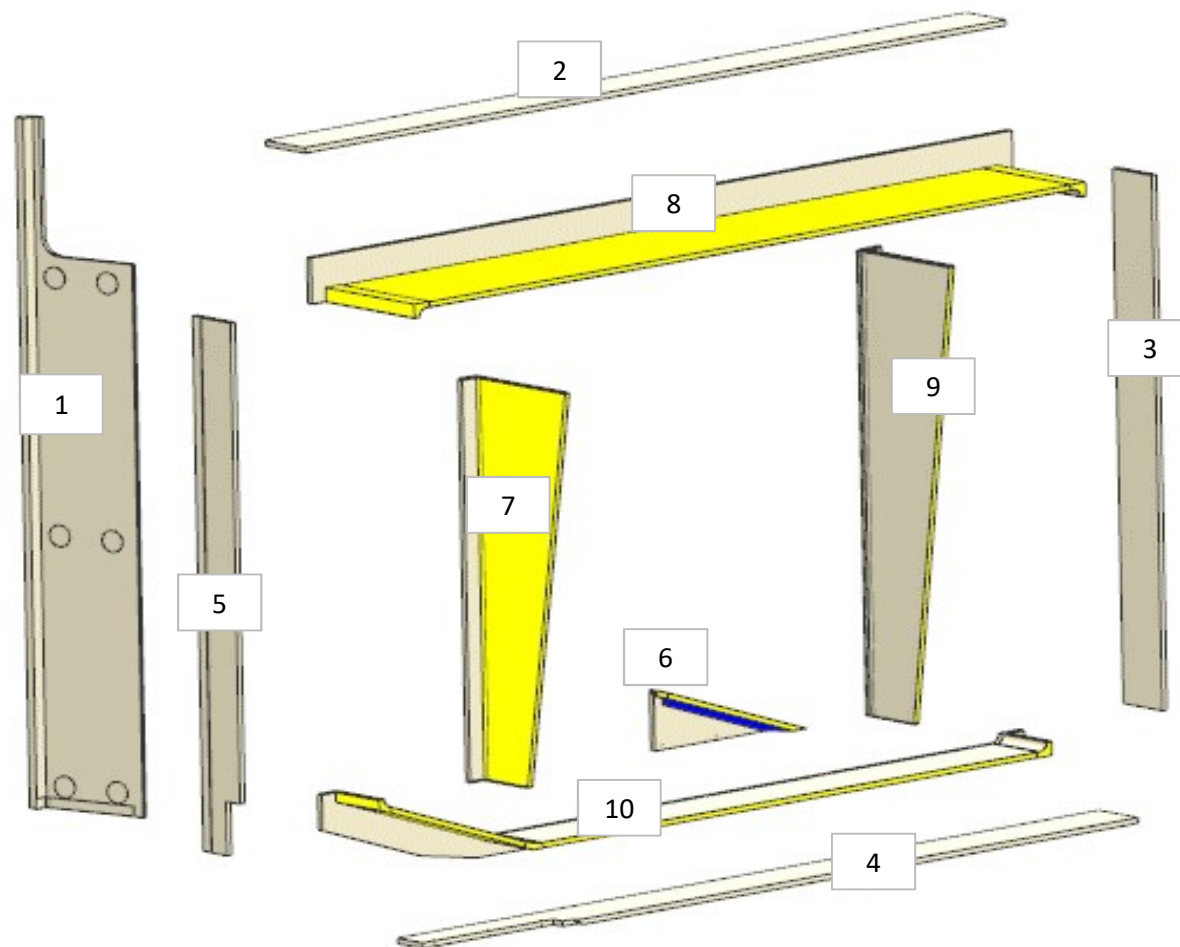

MOD AZ 146

Cartelle oblò più lunghe di 100 mm verso il carter
PZ. R01_AC01_07/08/09/10

MOD AZ 133

Modificare la scomposizione e direzione vena; divisione in 4 pezzi con tagli e scuretti

- 1 - sviluppo L. 344 x H 1997
- 2 - L. 2411 x H 148 x sp 16
- 3 - L. 1548 x H 148 x sp 16
- 4 - L. 2411 x H 148 x sp 16
- 5 - L. 1548 x H 148 x sp 16
- 6 - L. 473 x H 176 x 69
- 7 - L. 350 x H 1167 x 64
- 8 - L. 2411 x H 134 x 350
- 9 - L. 350 x H 1350 x 72
- 10 - L. 2412 x H 263 x 180

consonni&c

AZ26M

MOD GR5

REV. GR 9

LOCALE	CODICE	DESCRIZIONE COMPONENTE	FINITURA	Q.TA	OPERATORE
CABINA ARMATORE	AZ26M-R01_AD01	MURATA SX POPPA	LASTRA CHIARA	9	Damiano

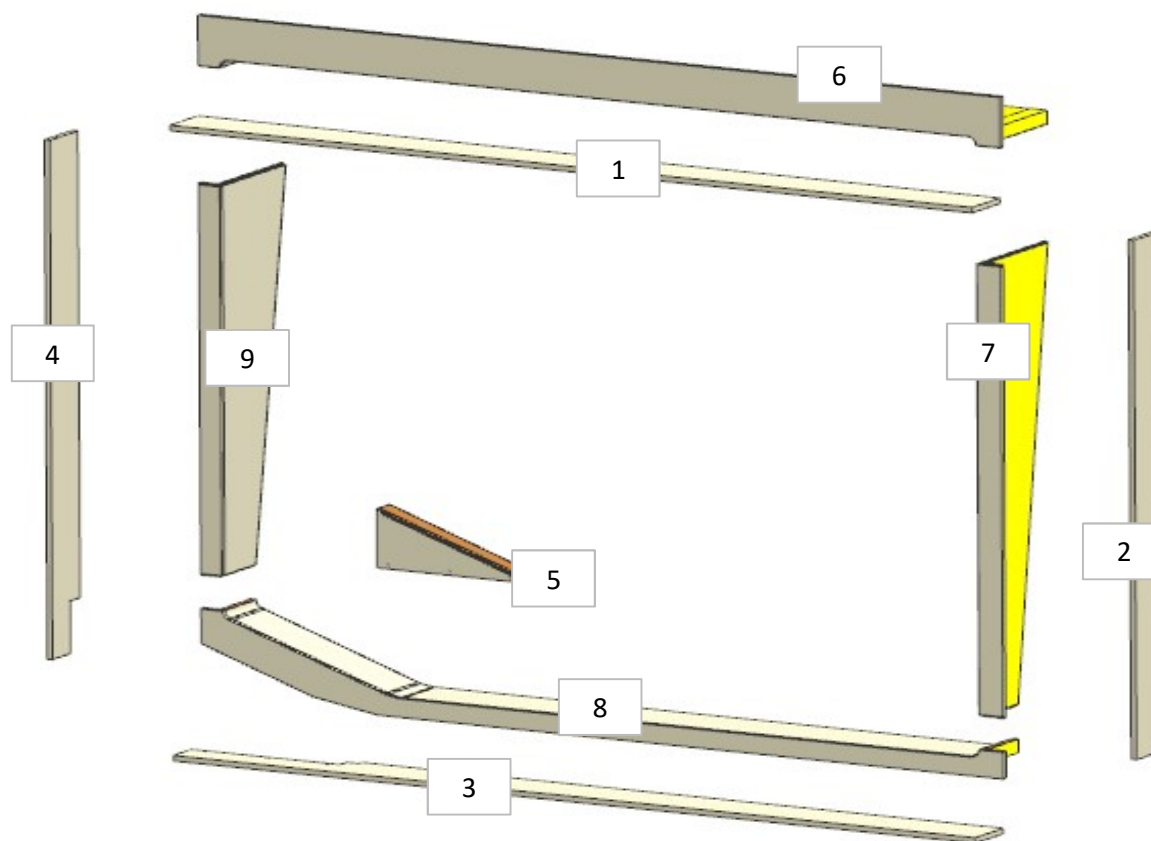

MOD AZ 146

Cartelle oblò più lunghe di 100 mm verso il carter
PZ. R01_AD01_06/07/08/09

MOD AZ 133

Modificare la scomposizione e direzione vena; divisione in 4 pezzi con tagli e scuretti

- 1 - L. 2411 x H 148 x sp 16
- 2 - L. 1548 x H 148 x sp 16
- 3 - L. 2411 x H 148 x sp 16
- 4 - L. 1548 x H 148 x sp 16
- 5 - L. 473 x H 176 x 69
- 6 - L. 2411 x H 151 x 350
- 7 - L. 243 x H 1350 x 350
- 8 - L. 2411 x H 263 x 180

AZ26M

REV. GR 9

LOCALE	CODICE	DESCRIZIONE COMPONENTE	FINITURA	Q.TA	OPERATORE
CABINA ARMATORE	AZ26M-R01_AE01	PARETE CENTRO NAVE	LASTRA CHIARA	2	Damiano

1 - L. 394 x H 1900 x sp 31
2 - L. 31x H 1900 x sp 31

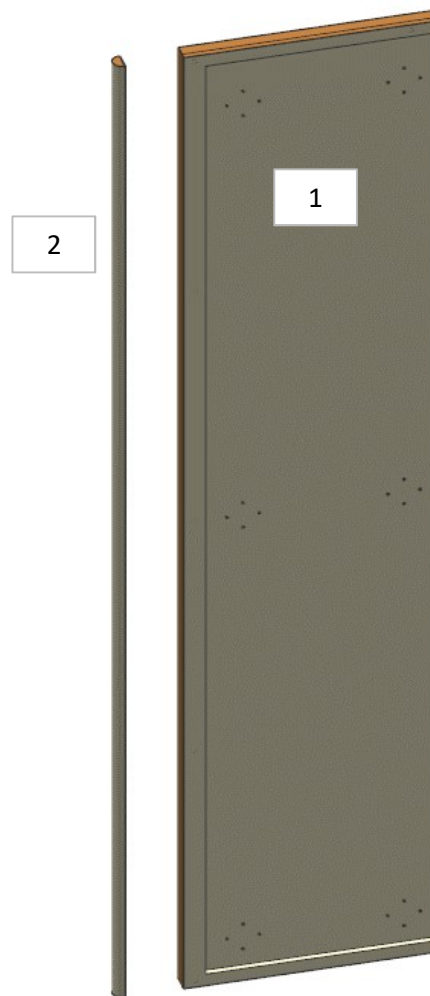

DETTAGLIO

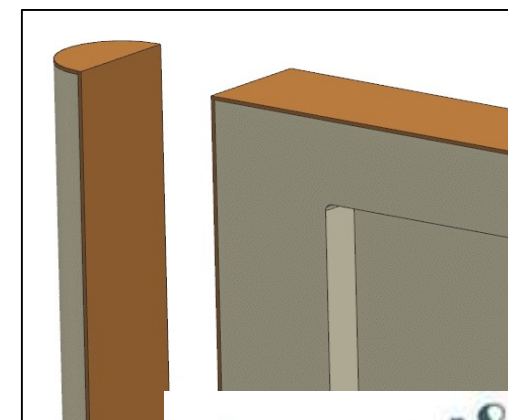

consonni&c

AZ26M

MOD PTP

REV. GR 9

LOCALE	CODICE	DESCRIZIONE COMPONENTE	FINITURA	Q.TA	OPERATORE
CABINA ARMATORE	AZ26M-R01_AG01	MOBILE SOSPESO ZONA TV	LASTRA CHIARA	6	Damiano

- 1 - L. 408 x H 66 x sp 16
- 2 - L. 438 x H 66 x sp 16
- 3 - L. 408 x H 36 x sp 16
- 4 - 6 - L. 408 x H 249 x sp 16
- 5 - L. 438 x H 249 x sp 16

MOD PTP
AGGIUNTO RIPIANI IN
LASTRA

ELEMENTO DA MONTARE con:
AG01
L01_AG01
L02_AG01
L03_AG01
L04_AG01
L05_AG01
e spedire con un unico imballo

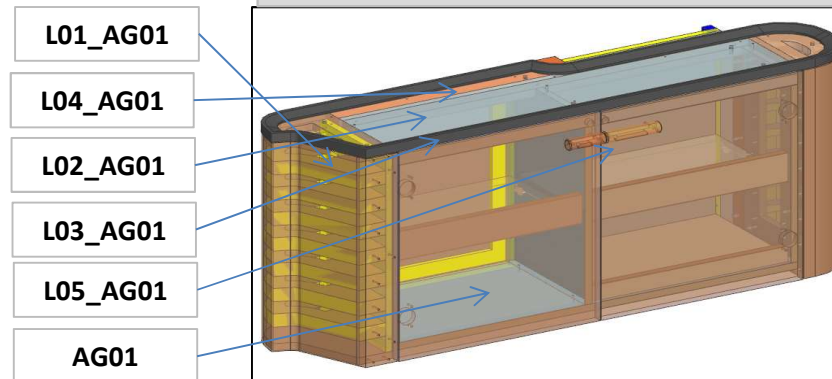
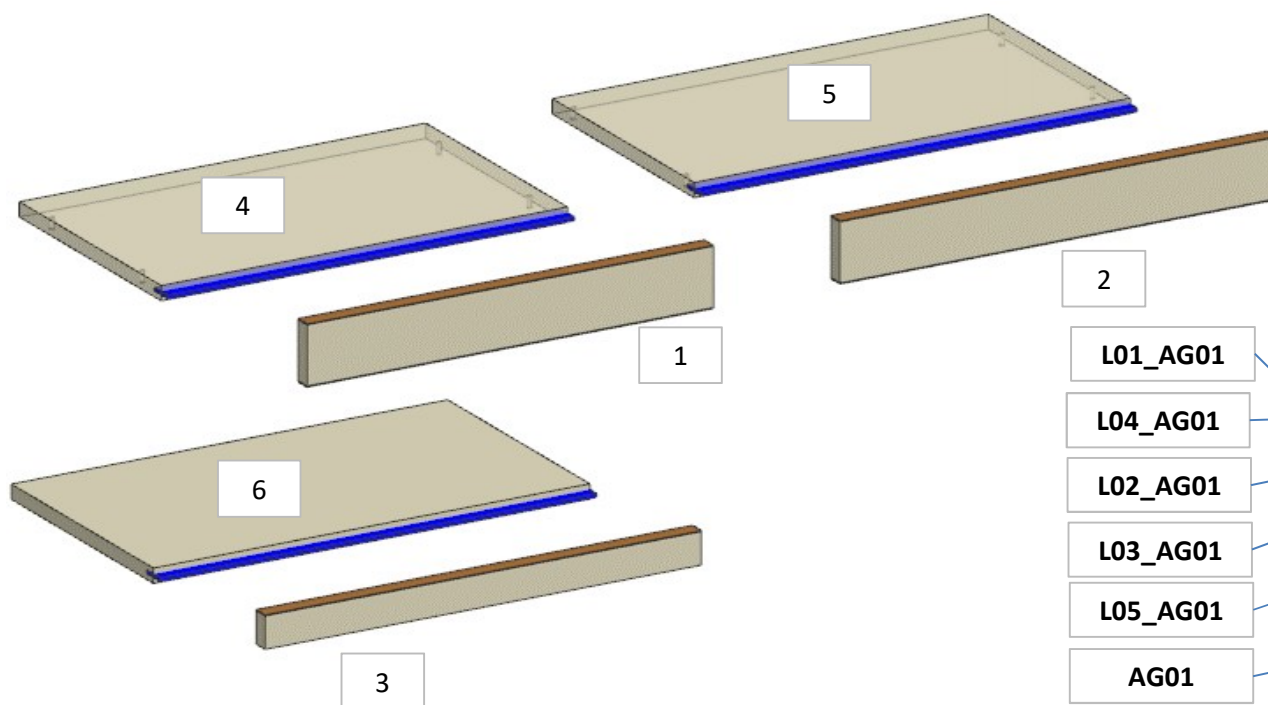

consonni&c

AZ26M

MOD GR4

REV. GR 9

LOCALE	CODICE	DESCRIZIONE COMPONENTE	FINITURA	Q.TA	OPERATORE
CABINA ARMATORE	AZ26M-R01_AH01	TESTATA LETTO	LASTRA CHIARA	6	Damiano

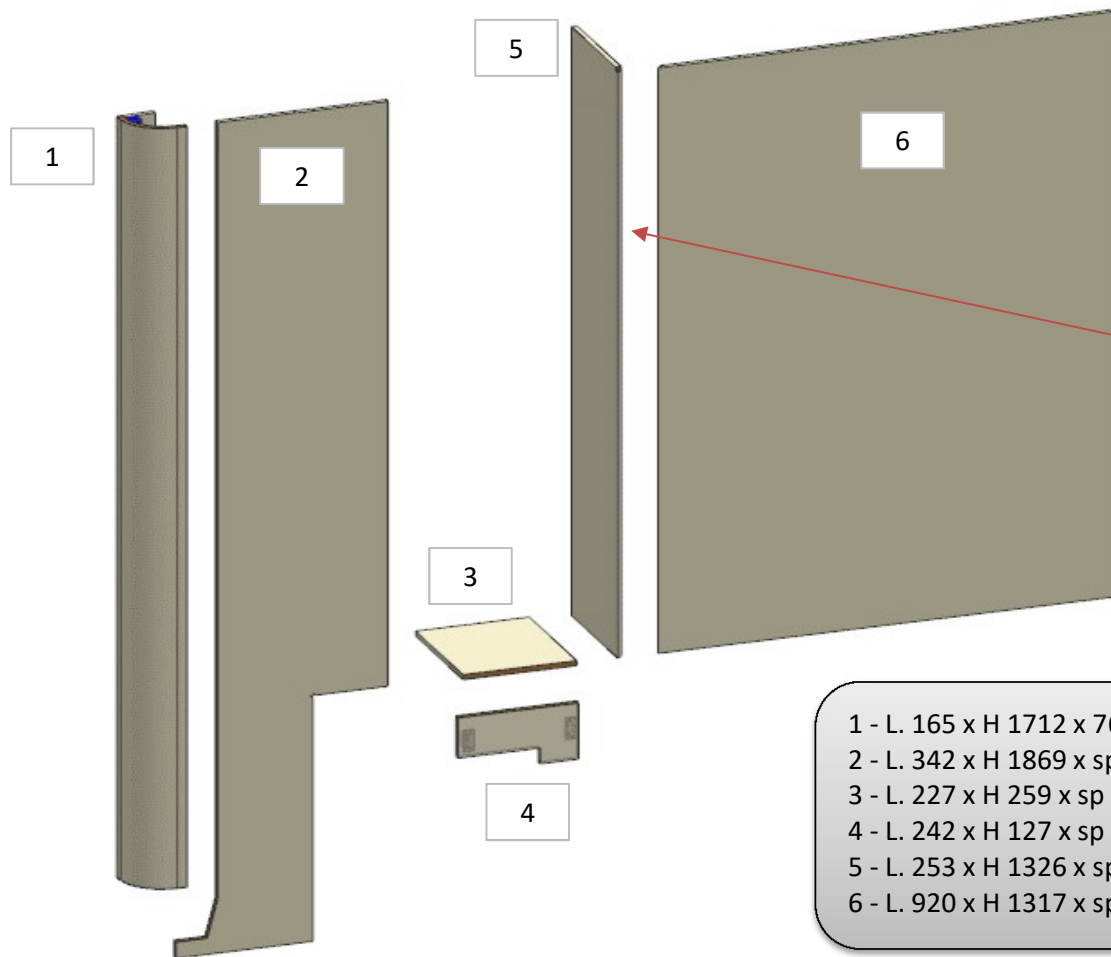

**ATTENZIONE:
LASTRE CON
ANGOLO A 45°**

- 1 - L. 165 x H 1712 x 76
- 2 - L. 342 x H 1869 x sp 11
- 3 - L. 227 x H 259 x sp 11
- 4 - L. 242 x H 127 x sp 11
- 5 - L. 253 x H 1326 x sp 11
- 6 - L. 920 x H 1317 x sp 11

ELEMENTO DA MONTARE
con:
X01_AH01
e spedire con un unico
imballo

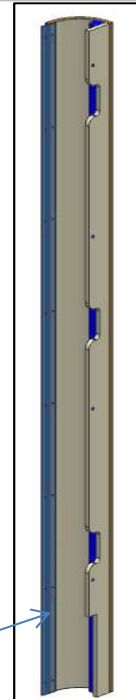

X01_AH01

AZ26M

REV. GR 9

LOCALE	CODICE	DESCRIZIONE COMPONENTE	FINITURA	Q.TA	OPERATORE
CABINA ARMATORE	AZ26M-R01_AJ01	CIELINO INGRESSO	LASTRA CHIARA	1	Damiano

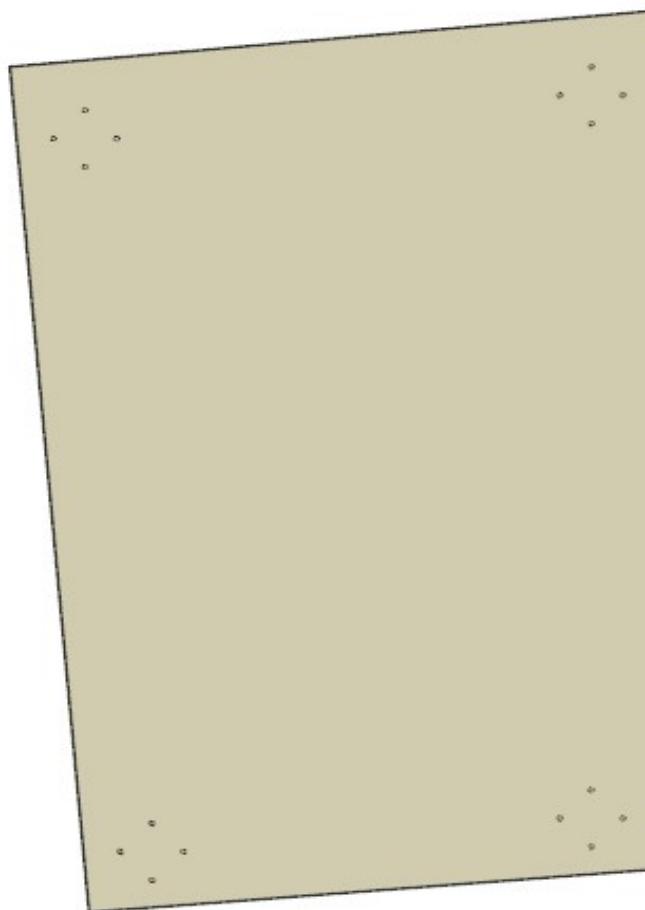

AZ26M

MOD GR5

REV. GR 9

LOCALE	CODICE	DESCRIZIONE COMPONENTE	FINITURA	Q.TA	OPERATORE
CABINA ARMATORE	AZ26M-R01_AP01	MURATA DX PRUA	LASTRA CHIARA	5	Damiano

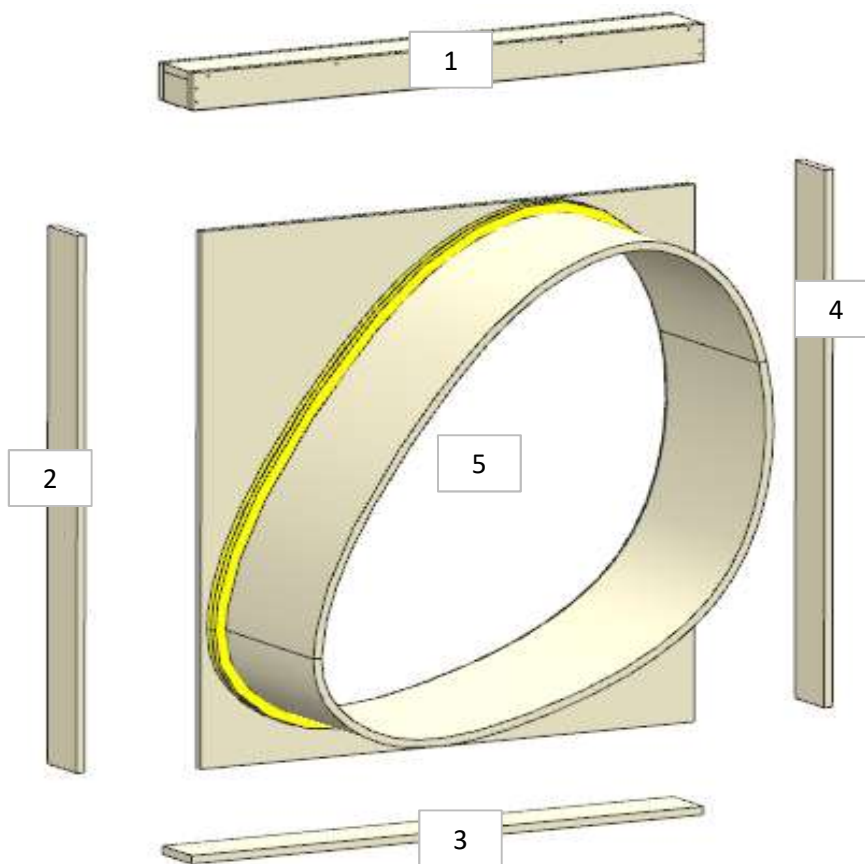

1 - L. 998 x H 72 x 121
2 - 4 - L. 105 x H 1044 x sp 16
3 - L. 105 x H 998 x sp 16
5 - L. 964 x H 1044 x sp 361

MOD AZ 242
AUMENTATA
PROFONDITA VANO

PZ 2-3 ELIMINATI E
ATTACCATI ALLA
LASTRA R01_AP01_05

AZ26M

REV. 01-2023

REV. GR 9

LOCALE	CODICE	DESCRIZIONE COMPONENTE	FINITURA	Q.TA	OPERATORE
CABINA ARMATORE	AZ26M-R01_AQ01	ARMADIO DRESSING PRUA CENTRONAVE STD-VAR1	LASTRA CHIARA	2	Damiano

1 - 2 - L 380 x H 1968 x sp 25
3 - 4 - L 53 x H 1918 x sp 6

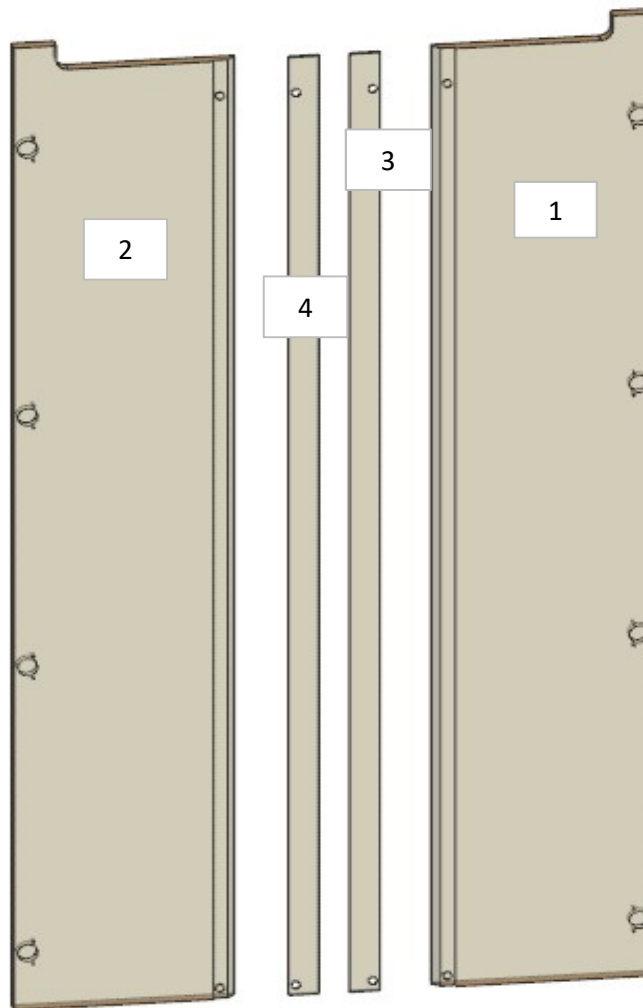

**ELEMENTO DA
MONTARE:
MG01
MG02**
e spedire con un unico
imballo

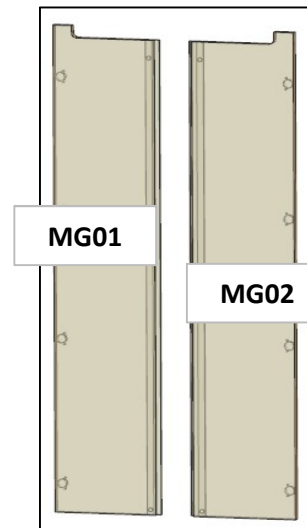

DETTAGLIO

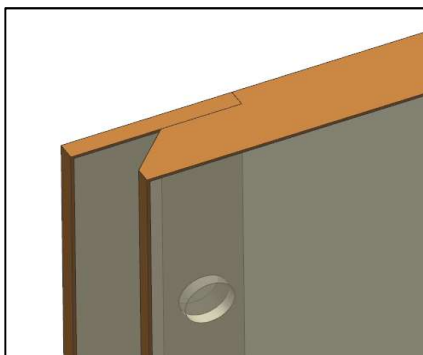

AZ26M

REV. GR 9

LOCALE	CODICE	DESCRIZIONE COMPONENTE	FINITURA	Q.TA	OPERATORE
CABINA ARMATORE	AZ26M-R01_AR01	PLENUM ARMADIO PRUA STD-VAR1	LASTRA CHIARA	1	Damiano

1 - L 790 x H 30 x sp 25

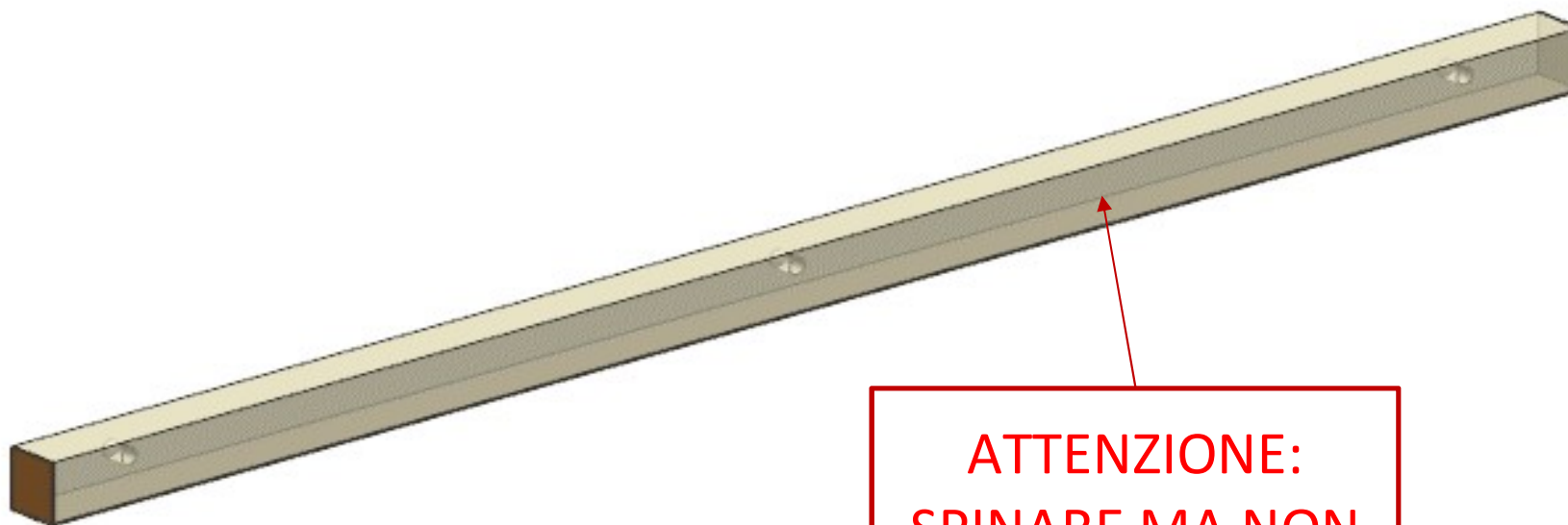

**ATTENZIONE:
SPINARE MA NON
INCOLLARE**

AZ26M

REV. 01-2023

REV. GR 9

LOCALE	CODICE	DESCRIZIONE COMPONENTE	FINITURA	Q.TA	OPERATORE
CABINA ARMATORE	AZ26M-R01_AS01	ARMADIO DRESSING MURATA DI PRUA	LASTRA CHIARA	3	Damiano

- 1 - L. 424 x H 2063 x sp 16
- 2 - L. 279 x H 98 x sp 16
- 3 - L 98 x H 448 x sp 16

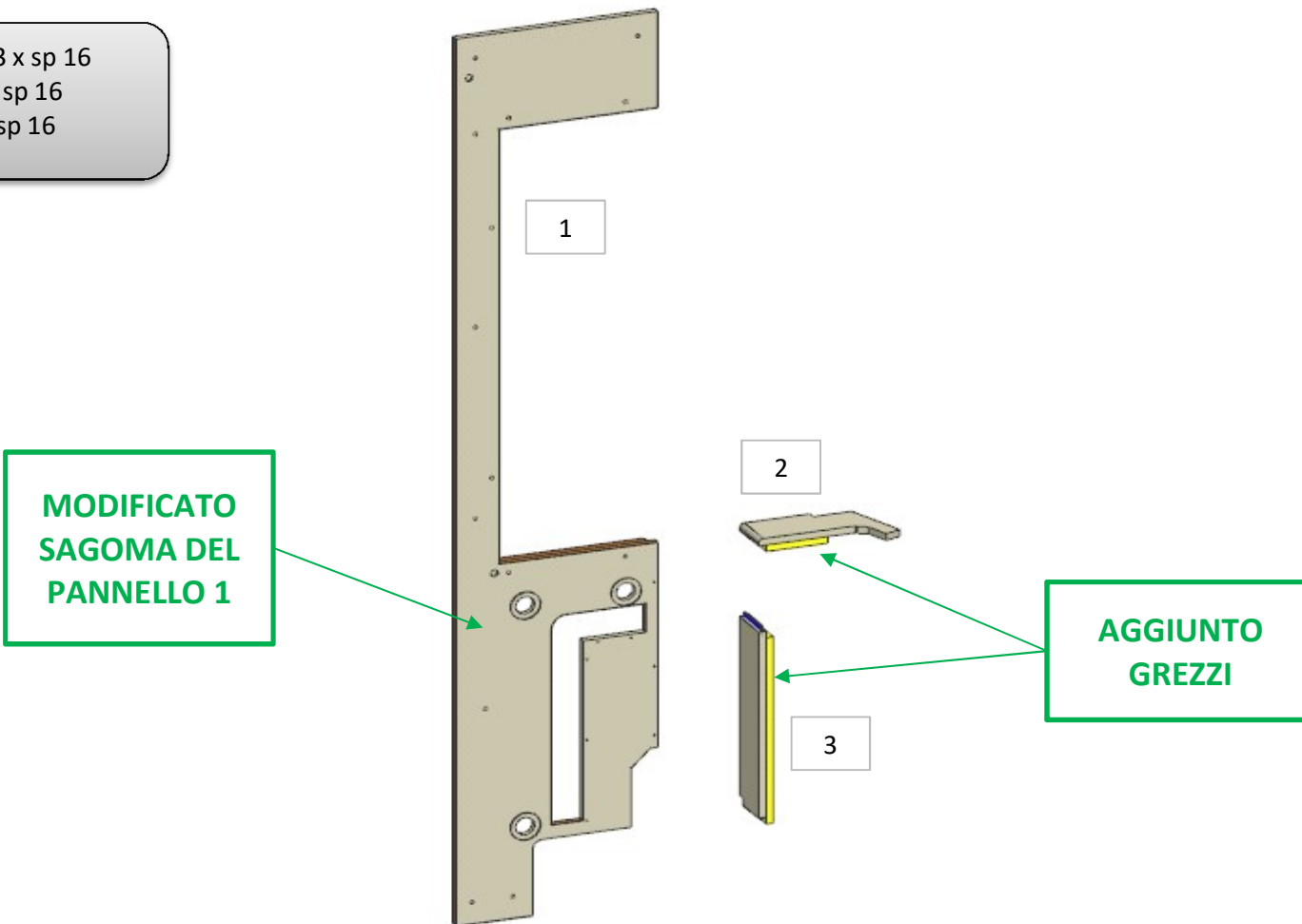

AZ26M

REV. GR 9

LOCALE	CODICE	DESCRIZIONE COMPONENTE	FINITURA	Q.TA	OPERATORE
CABINA ARMATORE	AZ26M-R01_AT01	CASSETTIERA DRESSING PRUA	LASTRA CHIARA	5	Damiano

- 1 - L. 338 x H 528 x 120
- 2 - 3 - L. 1126 x H 174 x sp 20
- 4 - L. 1126 x H 171 x sp 20
- 5 - L 186 x H 528 x 126

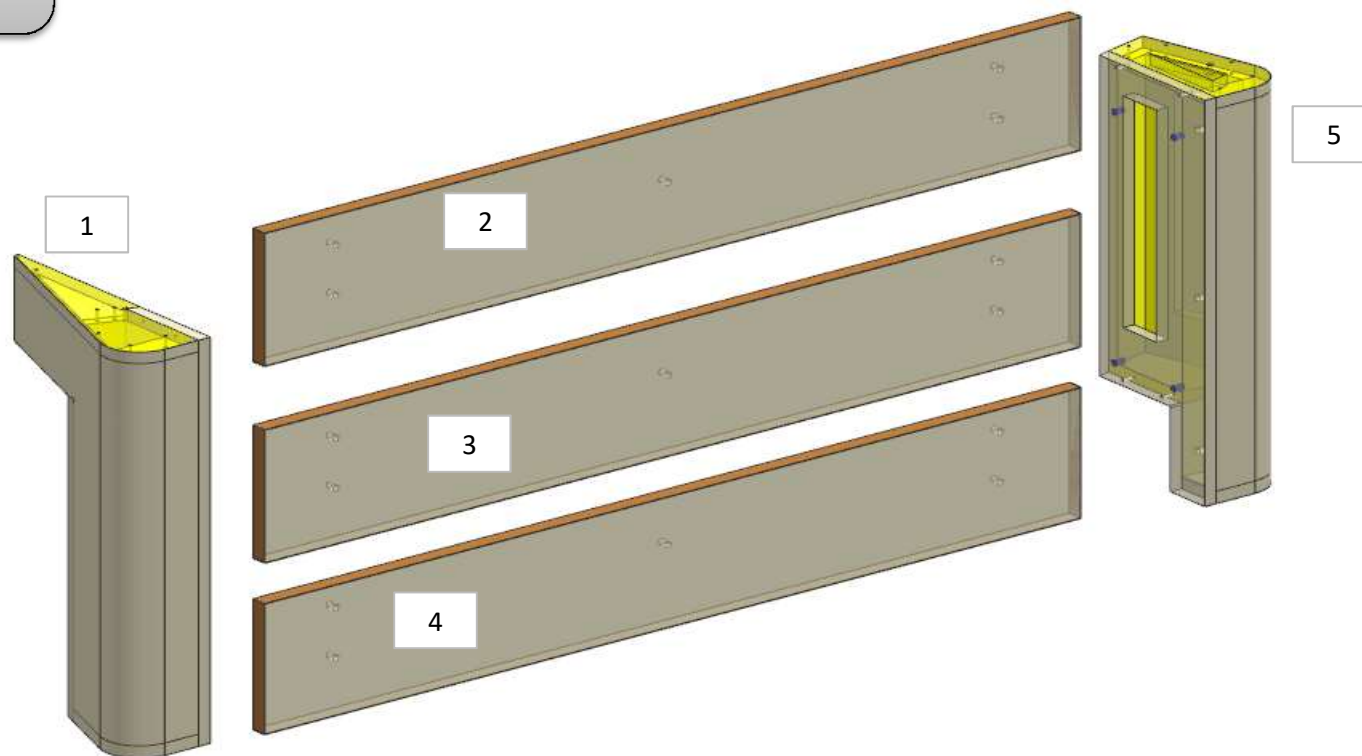

AZ26M

REV. GR 9

LOCALE	CODICE	DESCRIZIONE COMPONENTE	FINITURA	Q.TA	OPERATORE
CABINA ARMATORE	AZ26M-R01_AAQ01	ARMADIO DRESSING PRUA CENTRONAVE STD-VAR2	LASTRA CHIARA	2	Damiano

1 - L 377 x H 1968 x sp 25

ELEMENTO DA
MONTARE:
MG_AAQ01
e spedire con un unico
imballo

DETTAGLIO

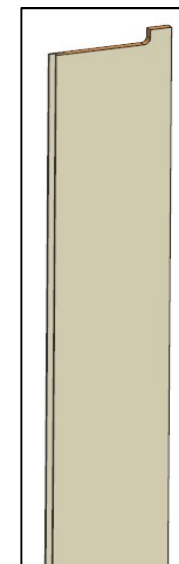
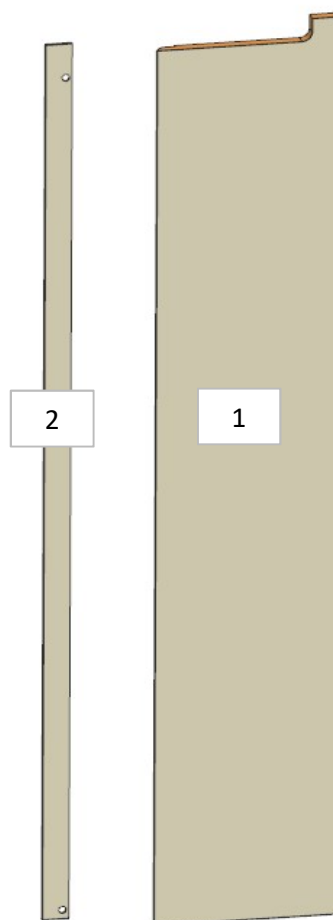
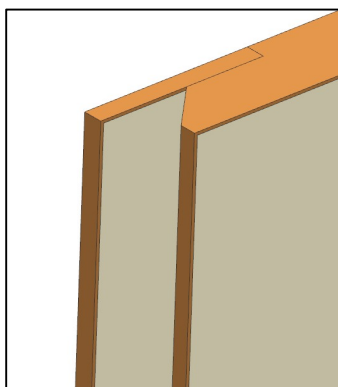

consonni&c

AZ26M

REV. GR 9

LOCALE	CODICE	DESCRIZIONE COMPONENTE	FINITURA	Q.TA	OPERATORE
CABINA ARMATORE	AZ26M-R01_AAR01	PLENUM ARMADIO PRUA STD-VAR2	LASTRA CHIARA	1	Damiano

1 - L 790 x H 30 x sp 25

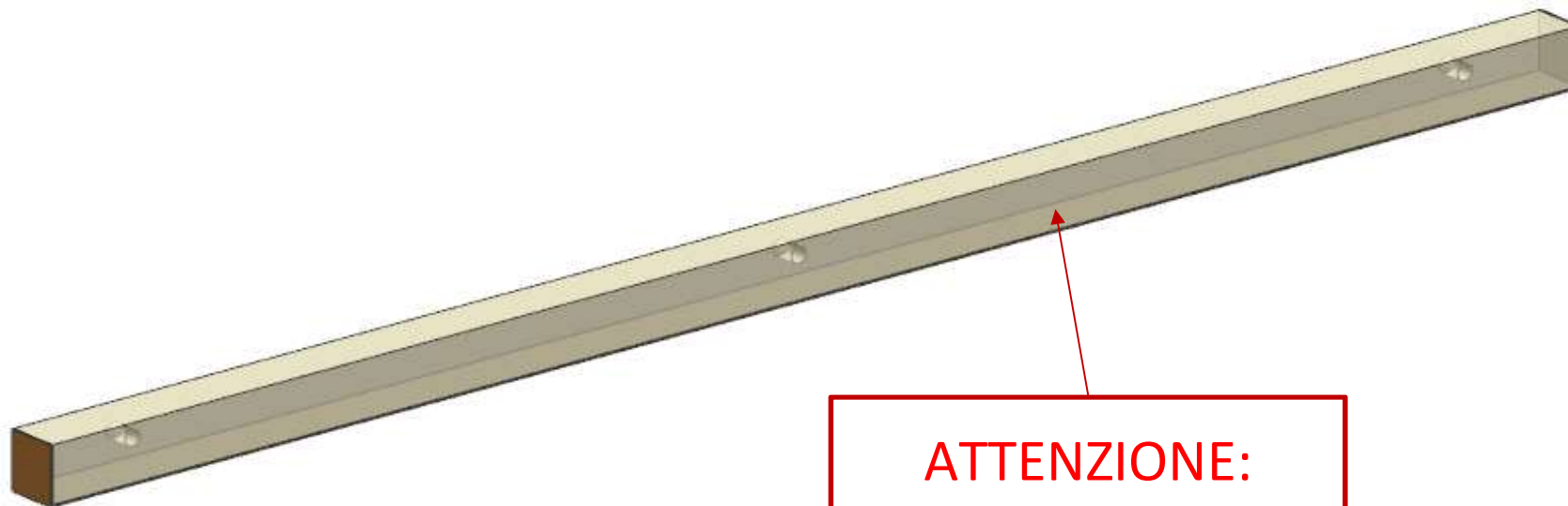

**ATTENZIONE:
SPINARE MA NON
INCOLLARE**