

AZ26M

REV. GR 9

LOCALE	CODICE	DESCRIZIONE COMPONENTE	FINITURA	Q.TA	OPERATORE
SALONE	AZ26M-X01_SA01	STRUTTURA MURATA DX PRUA	LAMINATO NERO	5	Damiano

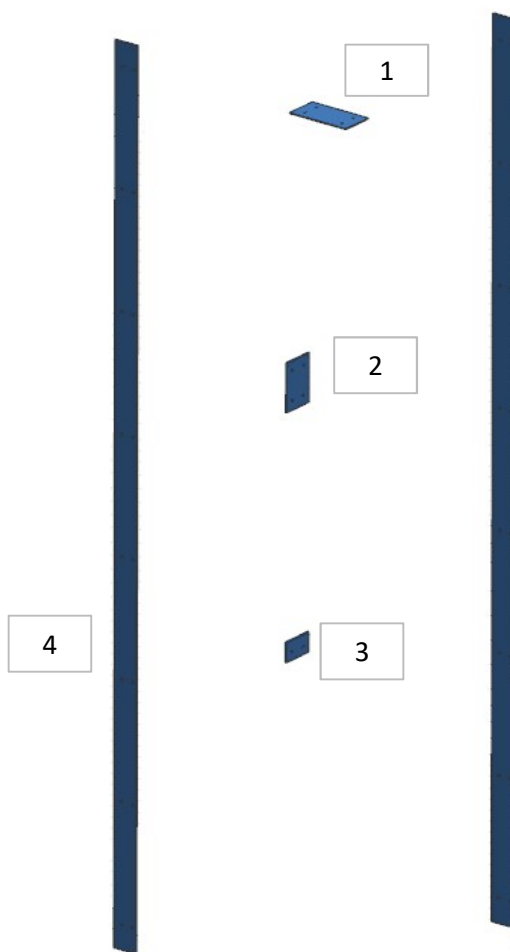

- 1 - L.115 x H 60 x sp 2
- 2 - L.98 x H 60 x sp 2
- 3 - L 41 x H 60 x sp 2
- 4 - 5 - L 46 x H 1787 x sp 2

ELEMENTO DA MONTARE con:
SA01
L01_SA01
e spedire con un unico imballo

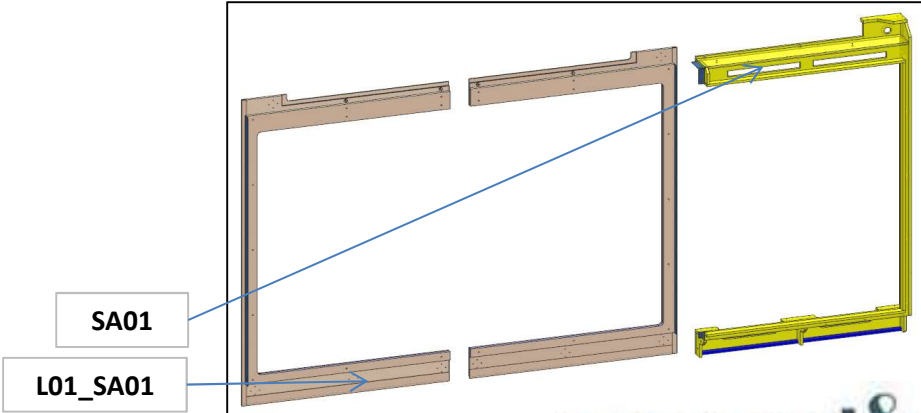

AZ26M

REV. GR 9

LOCALE	CODICE	DESCRIZIONE COMPONENTE	FINITURA	Q.TA	OPERATORE
SALONE	AZ26M-X01_SD01	STRUTTURA MURATA DX POPPA	LAMINATO NERO	2	Damiano

1 - 2 - L.46 x H 1787 x sp 2

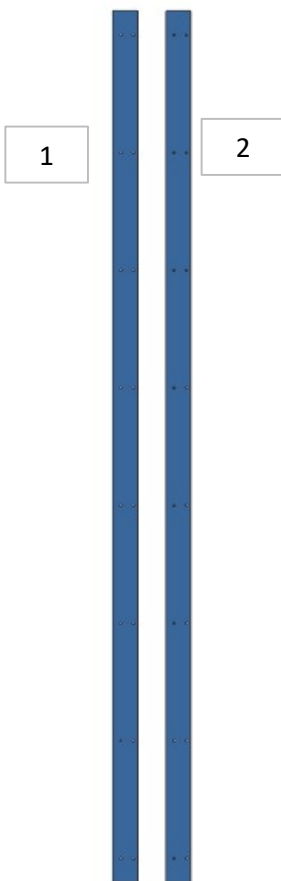

ELEMENTO DA MONTARE con:
L01_SD01
e spedire con un unico
imballo

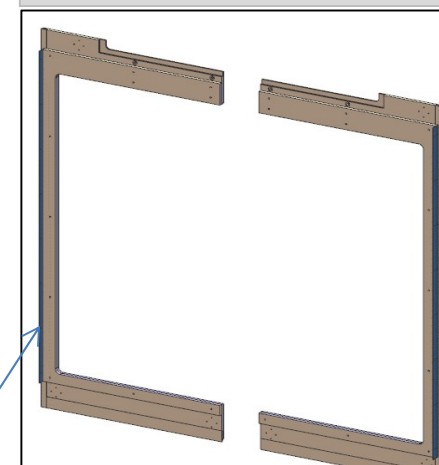

L01_SD01

consonni&c

AZ26M

REV. GR 9

LOCALE	CODICE	DESCRIZIONE COMPONENTE	FINITURA	Q.TA	OPERATORE
SALONE	AZ26M-X01_SF01	STRUTTURA MURATA SX PRUA	LAMINATO NERO	5	Damiano

- 1 - L.60 x H 115 x sp 2
- 2 - L.60 x H 98 x sp 2
- 3 - L.60 x H 41 x sp 2
- 4 - 5 - L 46 x H 1787 x sp 2

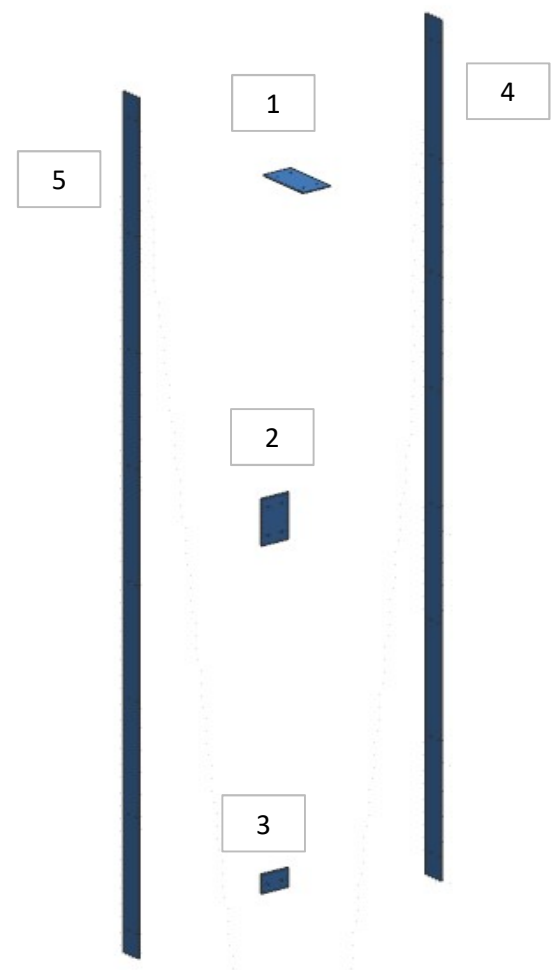

ELEMENTO DA MONTARE con:
SF01
L01_SF01
A01_SF01
 e spedire con un unico imballo

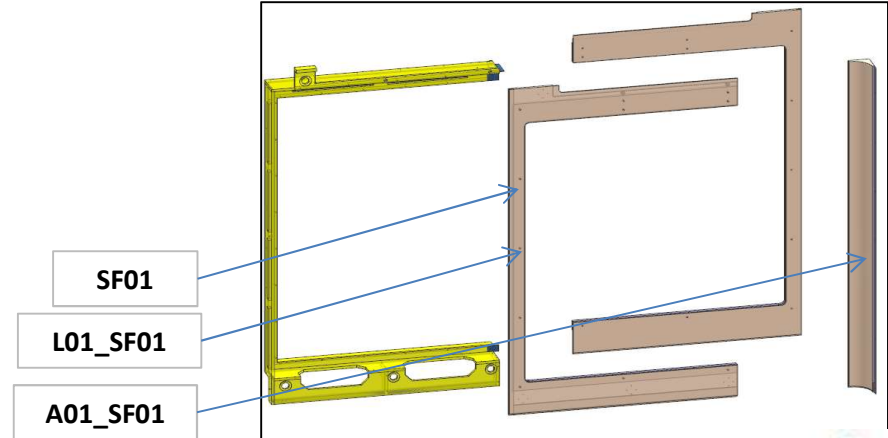

AZ26M

REV. GR 9

LOCALE	CODICE	DESCRIZIONE COMPONENTE	FINITURA	Q.TA	OPERATORE
SALONE	AZ26M-X01_SI01	STRUTTURA MURATA SX POPPA	LAMINATO NERO	5	Damiano

1

2

3

4

5

ELEMENTO DA MONTARE con:
SI01
L01_SI01
e spedire con un unico imballo

SI01

L01_SI01

consonni&c

AZ26M

REV. GR 9

LOCALE	CODICE	DESCRIZIONE COMPONENTE	FINITURA	Q.TA	OPERATORE
SALONE	AZ26M-X01_SY01	CIELINO ZONA TV A DISCESA	LAMINATO NERO	2	Dante

- 1 - sviluppo L.688 x H 88 x sp 2
- 2 - L. 1907 x H 50 x sp 2

