

# AZ26M

REV. 01-2023

REV. GR 9

LOCALE	CODICE	DESCRIZIONE COMPONENTE	FINITURA	Q.TA	OPERATORE
CABINA ARMATORE	AZ26M-L01_AB01	ARMADIO INGRESSO SX POPPA	LACCATO BRONZO	1	Damiano

1 - L.160 x H50 x sp 3

**ELIMINATO MF**

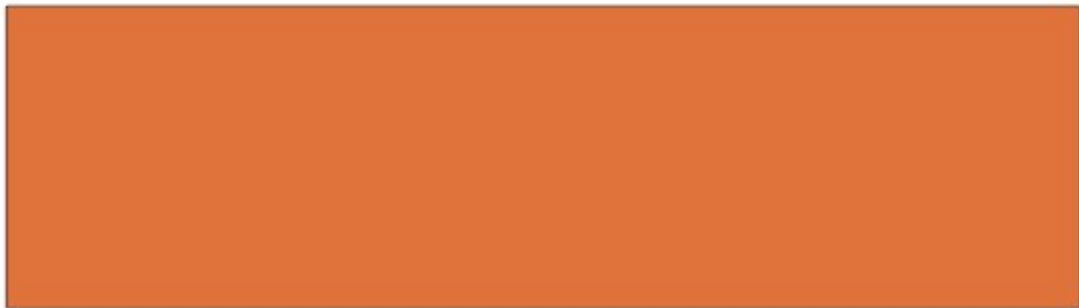

ELEMENTO DA MONTARE con:  
**R01\_AA01**  
e spedire con un unico imballo

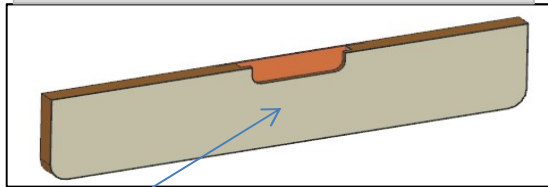

R01\_AA01

# AZ26M

MOD DA GR9

REV. GR 9

LOCALE	CODICE	DESCRIZIONE COMPONENTE	FINITURA	Q.TA	OPERATORE
CABINA ARMATORE	AZ26M-L01_AC01	MURATA DX POPPA	LACCATO BIANCO RAL 9010	5	Damiano

- 1 - SVILUPPO L.210 x H 1628 x sp 61
- 2 - L.1221 x H 1942 x sp 16
- 3 - L.1298 x H 1942 x sp 16
- 4 - L.18 x H 1942 x sp 6
- 5 - L.18 x H 1613 x sp 6

MOD AZ 216  
ALLUNGATO I RIVESTIMENTI VERSO  
PAVIMENTO E RIMOSI LAMINATI  
NERI ALLA BASE

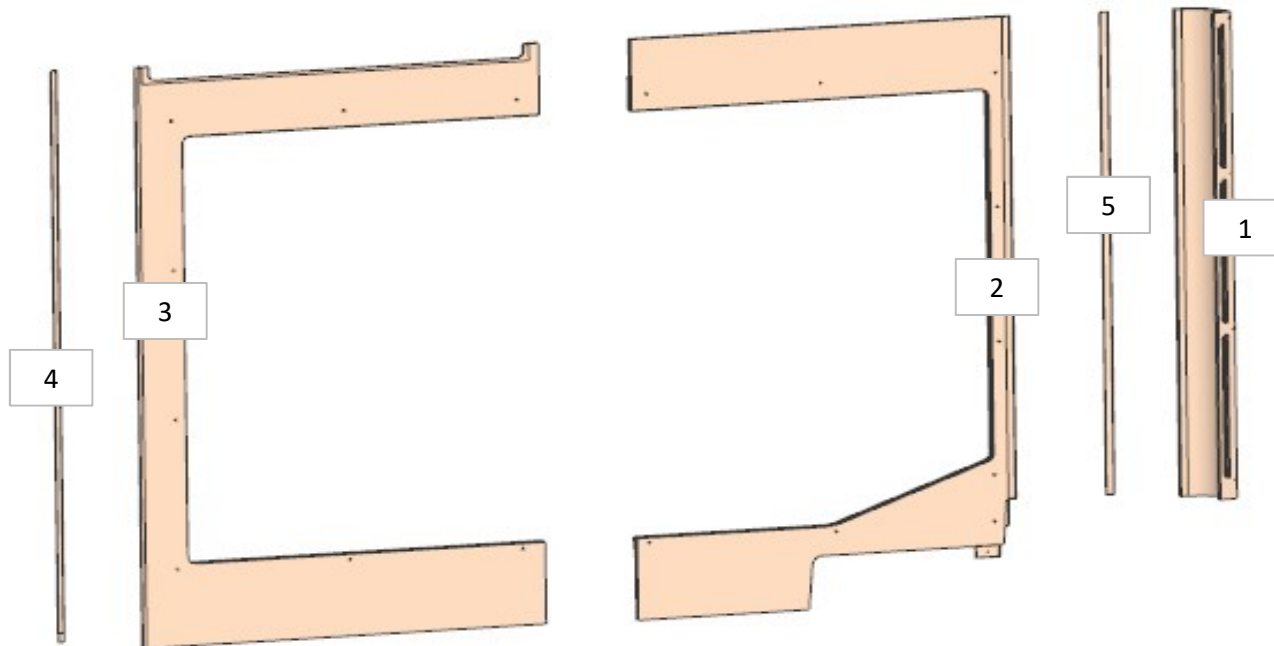

ELEMENTO DA MONTARE  
ASSIEME E SPEDIRE IN UN  
UNICO IMBALLO  
MG\_AC01  
MG\_AC02

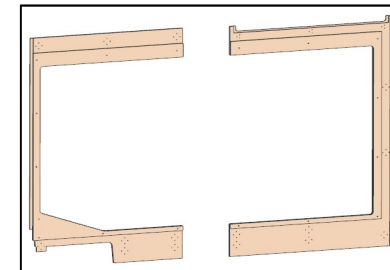

# AZ26M

MOD DA GR9

REV. GR 9

LOCALE	CODICE	DESCRIZIONE COMPONENTE	FINITURA	Q.TA	OPERATORE
CABINA ARMATORE	AZ26M-L01_AD01	MURATA SX POPPA	LACCATO BIANCO RAL 9010	5	Damiano

- 1 - L. 108 x H 1942 x sp 96
- 2 - L. 1309 x H 1942 x sp 16
- 3 - L. 1406 x H 1942 x sp 16
- 4 - L. 1406 x H 199 x sp 16
- 5 - L. 1406 x H 1942 x sp 16

MOD AZ 216  
ALLUNGATO I RIVESTIMENTI VERSO  
PAVIMENTO E RIMOSSI LAMINATI  
NERI ALLA BASE

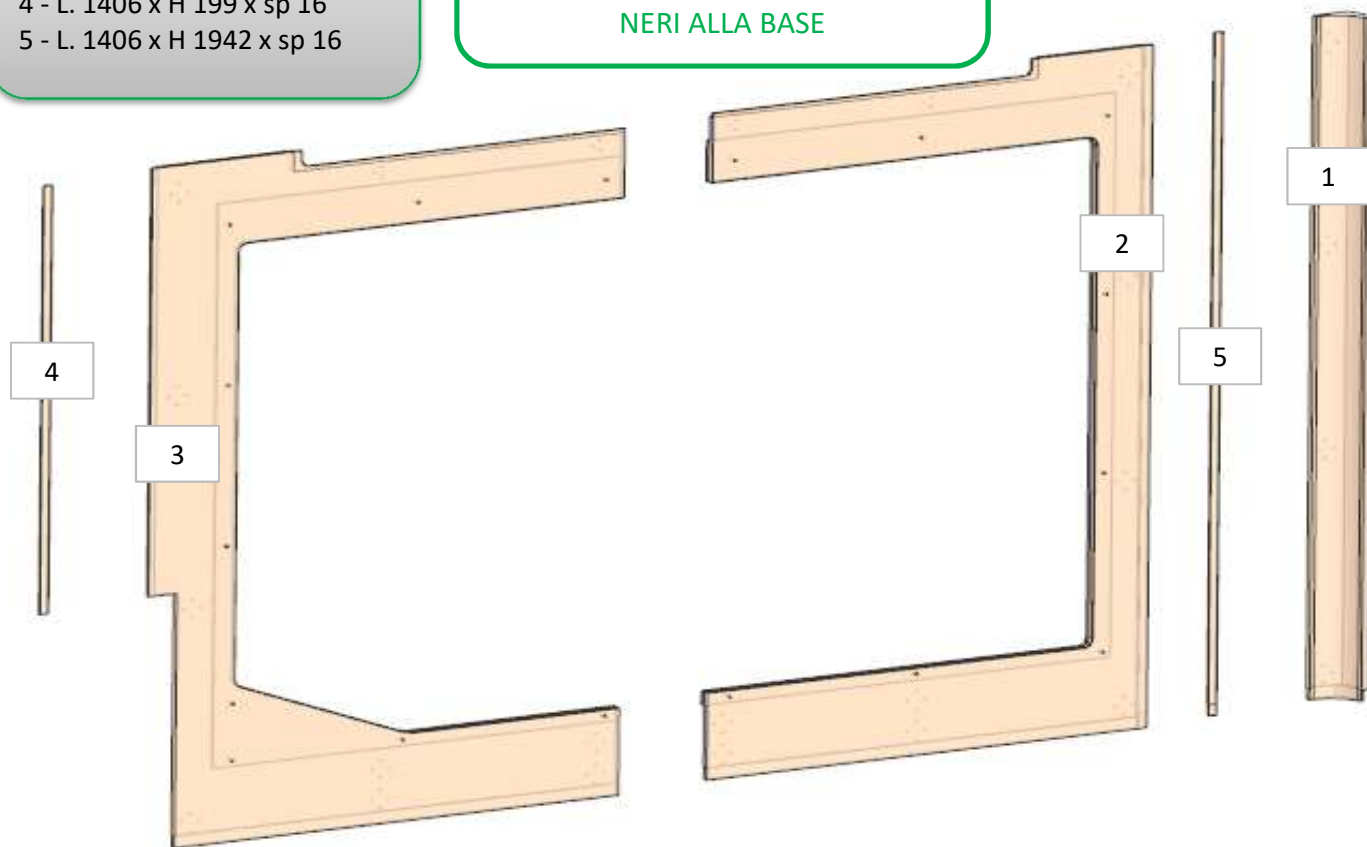

ELEMENTO DA MONTARE  
ASSIEME E SPEDIRE IN UN  
UNICO IMBALLO  
MG\_AD01  
MG\_AD02

# AZ26M

MOD DA GR9

REV. GR 9

LOCALE	CODICE	DESCRIZIONE COMPONENTE	FINITURA	Q.TA	OPERATORE
CABINA ARMATORE	AZ26M-L01_AE01	PARETE CENTRO NAVE	LACCATO BIANCO RAL 9010	5	Damiano

- 1 - L. 685 x H 1352 x sp 10
- 2 - L. 1736 x H 85 x sp 10
- 3 - L. 44 x H 1850 x sp 10
- 4 - L. 1736 x H 119 x sp 10
- 5 - L. 685 x H 245 x sp 10

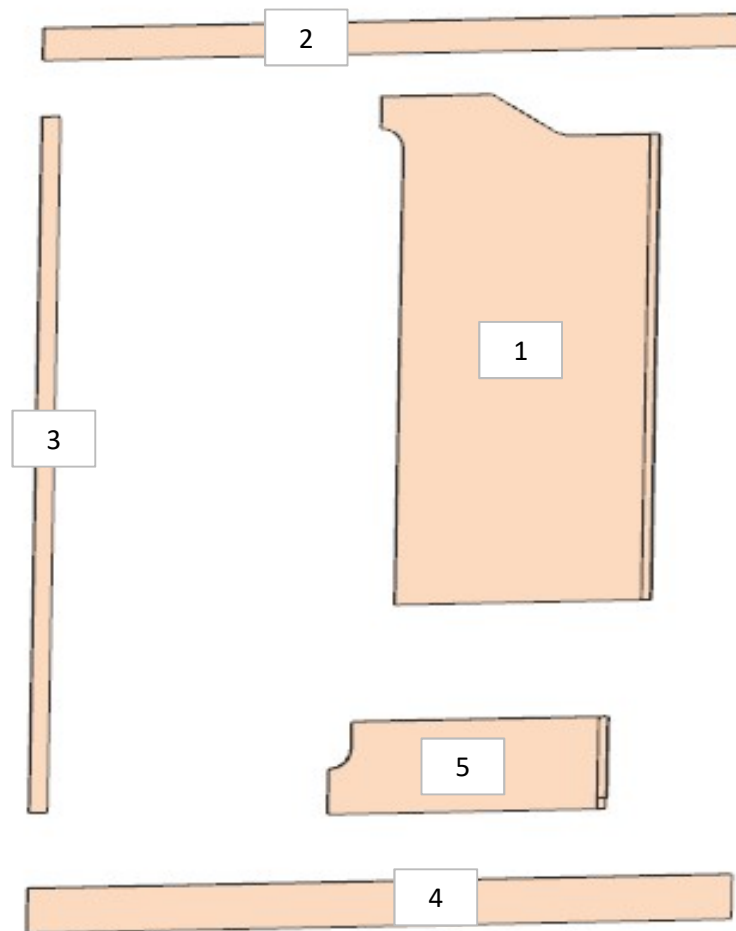

MOD AZ 216  
ALLUNGATO I RIVESTIMENTI VERSO  
PAVIMENTO E RIMOSSI LAMINATI  
NERI ALLA BASE

# AZ26M

REV. GR 9

LOCALE	CODICE	DESCRIZIONE COMPONENTE	FINITURA	Q.TA	OPERATORE
CABINA ARMATORE	AZ26M-L02_AE01	PARETE CENTRO NAVE	LACCATO BRONZO	1	Damiano

1 - L. 256 x H 1849 x sp 100

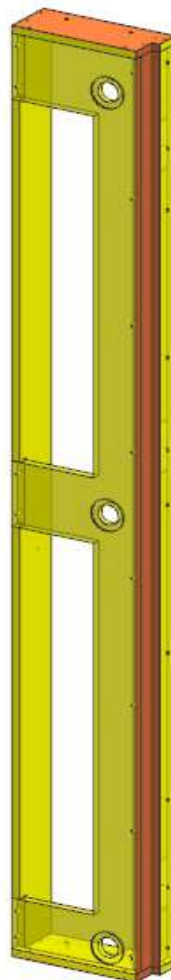

# AZ26M

REV. GR 9

LOCALE	CODICE	DESCRIZIONE COMPONENTE	FINITURA	Q.TA	OPERATORE
CABINA ARMATORE	AZ26M-L01_AF01	CORNICE TV	GREZZ\LACC.BRONZO\ SPRUZZ. NERO	3	Damiano

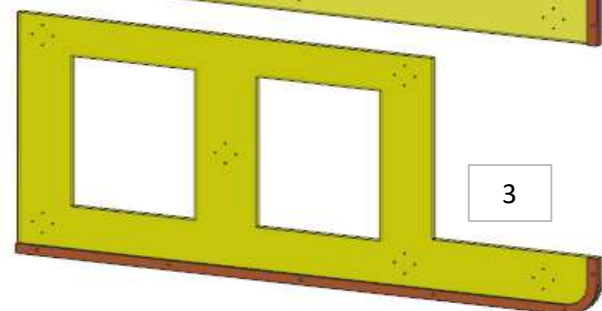
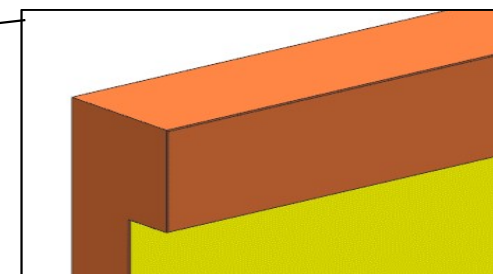
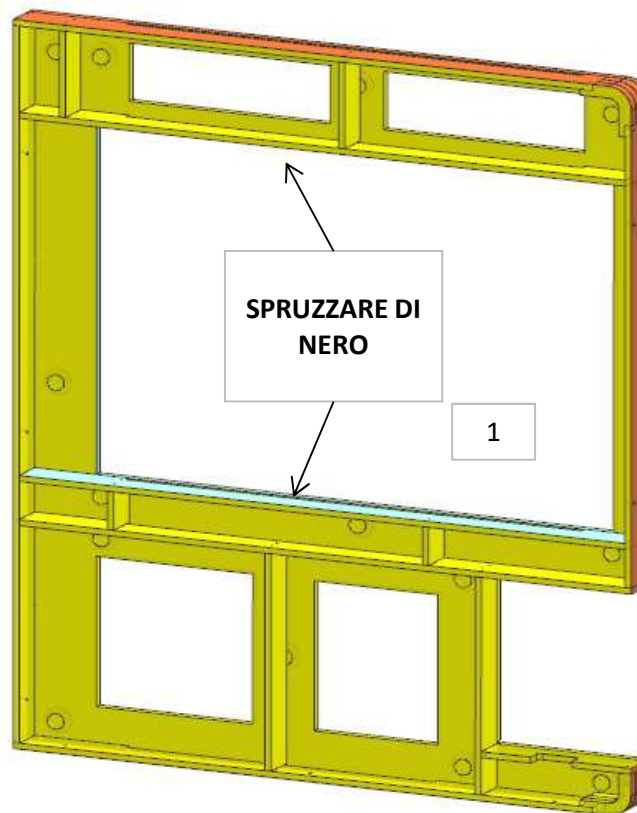
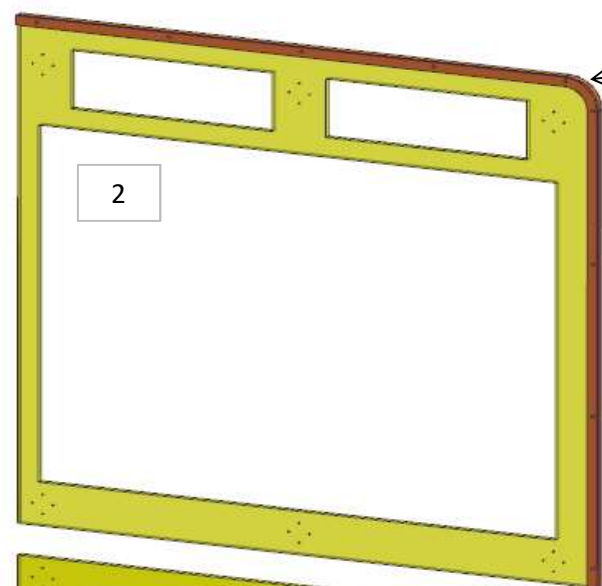

ELEMENTO DA MONTARE  
ASSIEME E SPEDIRE IN UN  
UNICO IMBALLO  
MG\_AF01

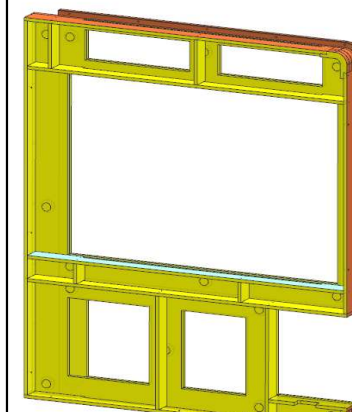

consonni&c

# AZ26M

MOD PTP

REV. GR 9

LOCALE	CODICE	DESCRIZIONE COMPONENTE	FINITURA	Q.TA	OPERATORE
CABINA ARMATORE	AZ26M-L01_AG01	MOBILE SOSPESO ZONA TV	LACCATO NCS S3020-Y30R	4	Damiano

1 - L. 219 x H 475 x sp 125  
2 - 3 - L. 445 x H 473 x sp 20  
4 - L. 276 x H 475 x sp 177

**MOD PTP**  
MODIFICATO ANTE

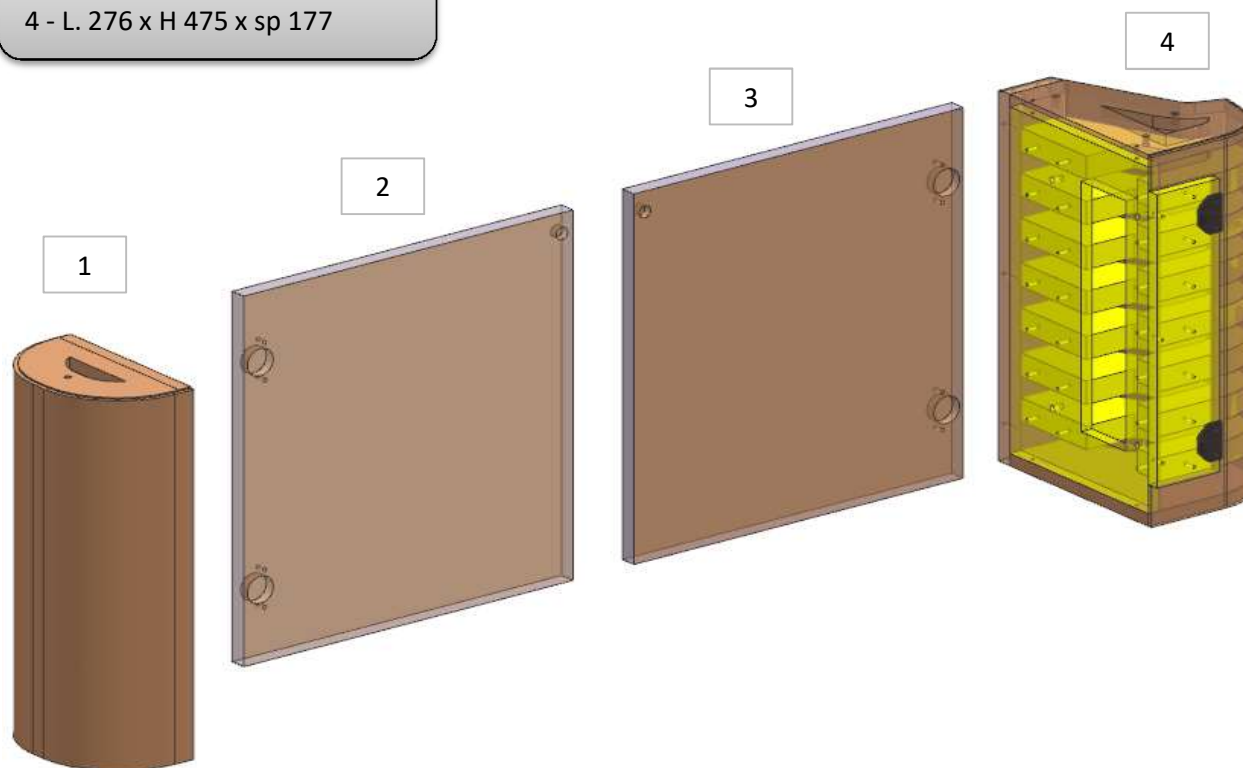

# AZ26M

MOD PTP

REV. GR 9

LOCALE	CODICE	DESCRIZIONE COMPONENTE	FINITURA	Q.TA	OPERATORE
CABINA ARMATORE	AZ26M-L02_AG01	MOBILE SOSPESO ZONA TV	LACCATO BRONZO	5	Damiano

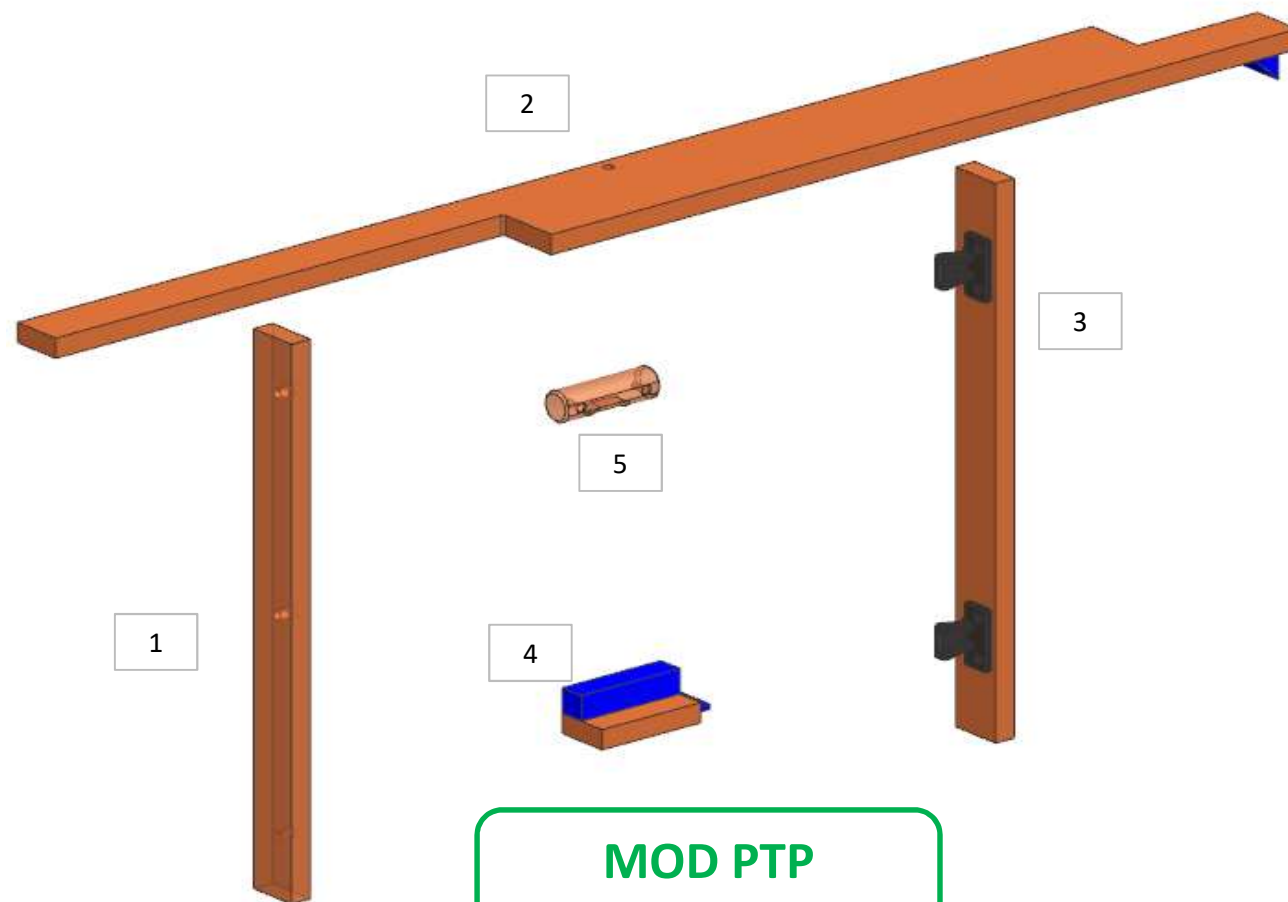

- 1 - L. 39 x H 441 x sp 16
- 2 - L. 1013 x H 89 x sp 16
- 3 - L. 41 x H 441 x sp 16
- 4 - L. 41 x H 83 x sp 16

**MOD PTP**  
AGGIUNTO MANIGLIA

# AZ26M

MOD PTP

REV. GR 9

LOCALE	CODICE	DESCRIZIONE COMPONENTE	FINITURA	Q.TA	OPERATORE
CABINA ARMATORE	AZ26M-L03_AG01	MOBILE SOSPESO ZONA TV	LACCATO BIANCO RAL 9010	1	Damiano

1 - L. 1168 x H 236 x sp 8



# AZ26M

MOD PTP

REV. GR 9

LOCALE	CODICE	DESCRIZIONE COMPONENTE	FINITURA	Q.TA	OPERATORE
CABINA ARMATORE	AZ26M-L04_AG01	MOBILE SOSPESO ZONA TV	LACCATO LUCIDO MOGANO 100 Gloss	1	Damiano



# AZ26M

**MOD PTP**

REV. GR 9

LOCALE	CODICE	DESCRIZIONE COMPONENTE	FINITURA	Q.TA	OPERATORE
CABINA ARMATORE	AZ26M-L05_AG01	MOBILE SOSPESO ZONA TV	LACCATO ARANCIONE - NCS S2050-Y50R 100 gloss	1	Damiano

**MOD PTP**

AGGIUNTO MANIGLIA LACCATA  
ARANCIONE

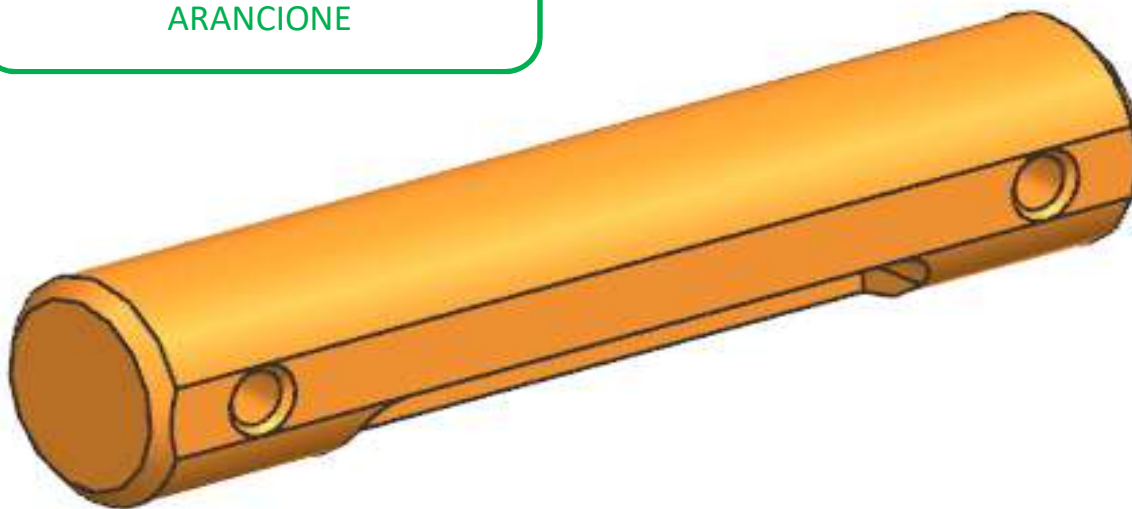

# AZ26M

REV. GR 9

LOCALE	CODICE	DESCRIZIONE COMPONENTE	FINITURA	Q.TA	OPERATORE
CABINA ARMATORE	AZ26M-L01_AH01	TESTATA LETTO	LACCATO BIANCO RAL 9010	9	Damiano

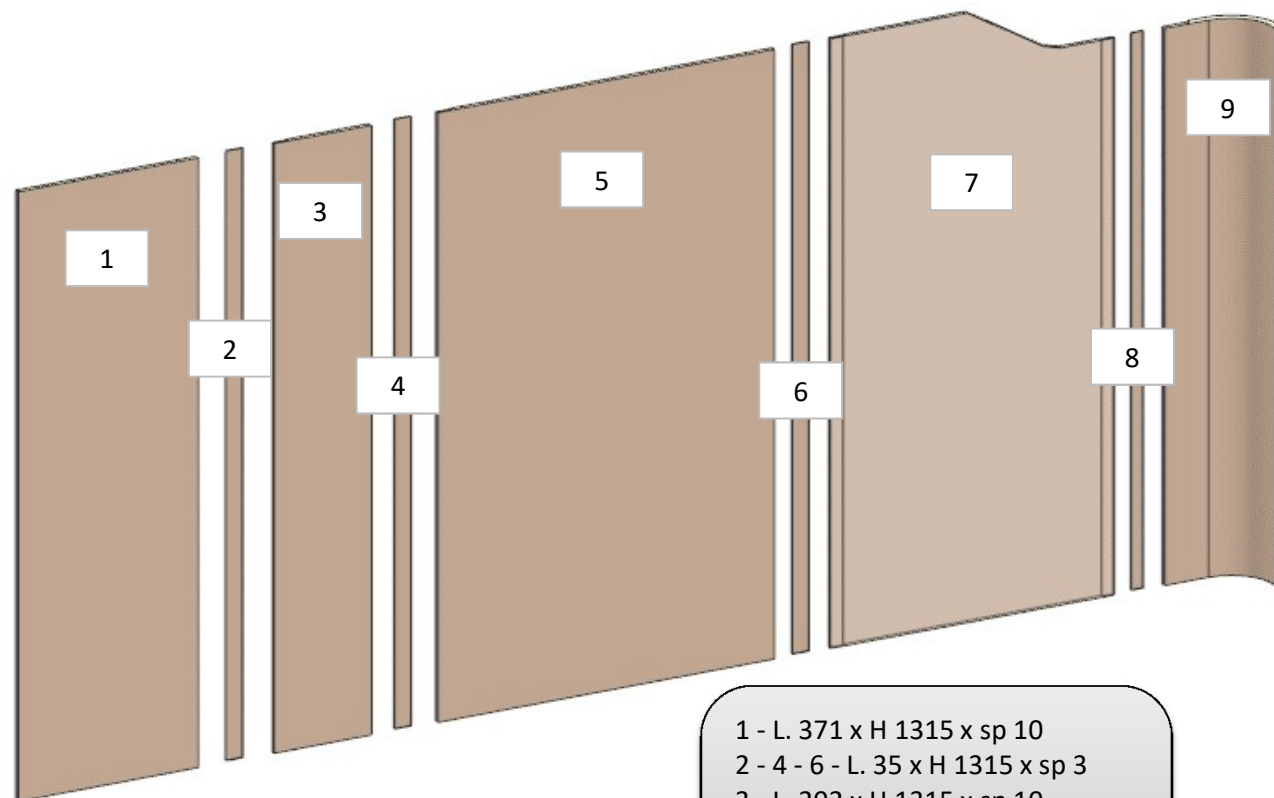

- 1 - L. 371 x H 1315 x sp 10
- 2 - 4 - 6 - L. 35 x H 1315 x sp 3
- 3 - L. 202 x H 1315 x sp 10
- 5 - L. 694 x H 1315 x sp 10
- 7 - L. 585 x H 1315 x sp 10
- 8 - L. 25 x H 1202 x sp 3
- 9 - L. 255 x H 1202 x sp 16

**ELEMENTO DA MONTARE:**  
**MF\_AH02**  
**MG\_AH01**  
**MG\_AH02**  
**MG\_AH03**  
**A01\_AG01**  
 e spedire con un unico imballo

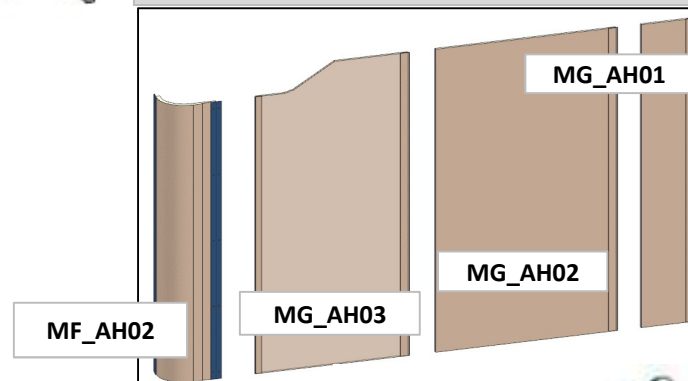

# AZ26M

REV. GR 9

LOCALE	CODICE	DESCRIZIONE COMPONENTE	FINITURA	Q.TA	OPERATORE
CABINA ARMATORE	AZ26M-L02_AH01	TESTATA LETTO	LACCATO NCS S3020-Y30R	1	Damiano



**consonni&c**

# AZ26M

REV. GR 9

LOCALE	CODICE	DESCRIZIONE COMPONENTE	FINITURA	Q.TA	OPERATORE
CABINA ARMATORE	AZ26M-L03_AH01	TESTATA LETTO	LACCATO LUCIDO MOGANO 100 GLOSS	1	Damiano

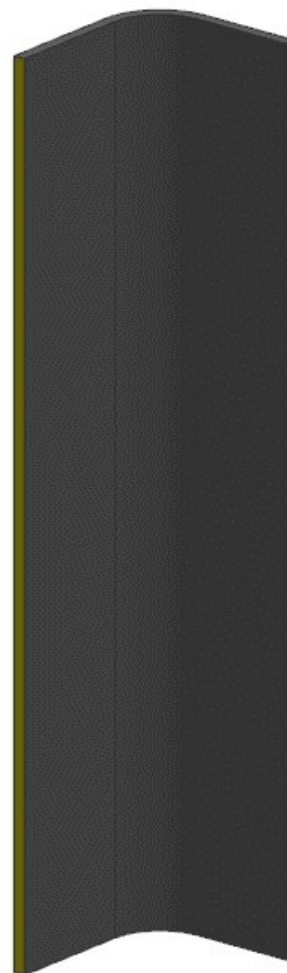

# AZ26M

MOD GR4

REV. GR 9

LOCALE	CODICE	DESCRIZIONE COMPONENTE	FINITURA	Q.TA	OPERATORE
CABINA ARMATORE	AZ26M-L04_AH01	VASCHETTA		4	Damiano

MOD. INT. 22  
VASCHETTA DIVENTATA  
LACCATA AZ26M-  
MG\_AH01

- 1 - L. 183 x H 226 x sp 12
- 2 - L. 196 x H 227 x sp 12
- 3 - L. 192 x H 60 x sp 12
- 4 - L. 215 x H 60 x sp 12

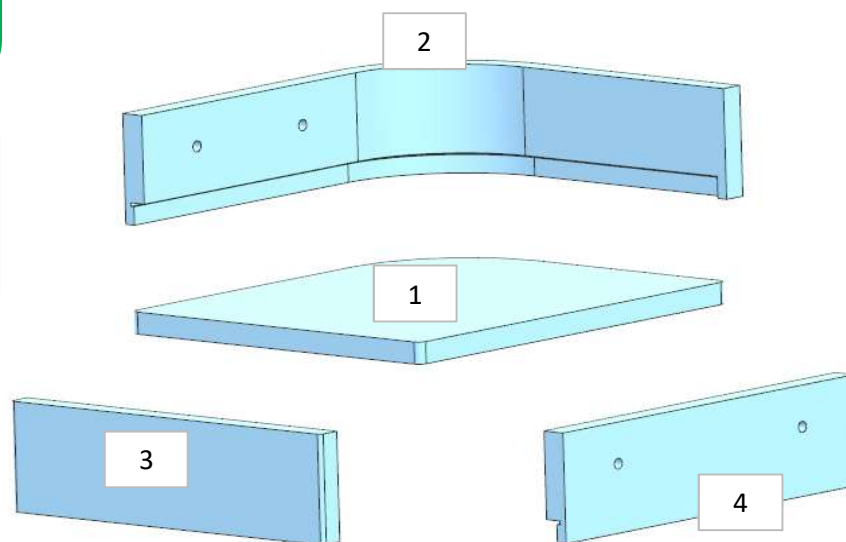

ELEMENTO DA MONTARE:  
AZ26M-L04\_AH01\_01  
AZ26M-L04\_AH01\_02  
AZ26M-L04\_AH01\_03  
AZ26M-L04\_AH01\_04  
e spedire con un unico imballo

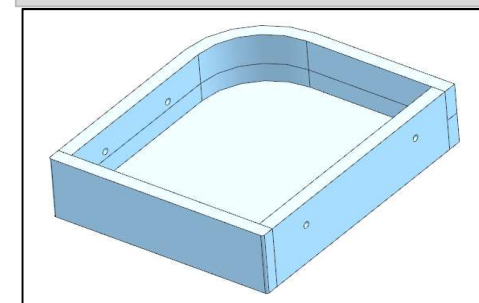

**CAPRI:** LACCATO AZZURRO ACQUAMARINA opaco  
**RIVIERA:**  
**NEUTRO -** LACCATO BRONZO A CAMPIONE

# AZ26M

MOD PTP

REV. GR 9

LOCALE	CODICE	DESCRIZIONE COMPONENTE	FINITURA	Q.TA	OPERATORE
CABINA ARMATORE	AZ26M-L01_AI01	COMODINO SX	LACCATO BIANCO RAL 9016	5	Damiano

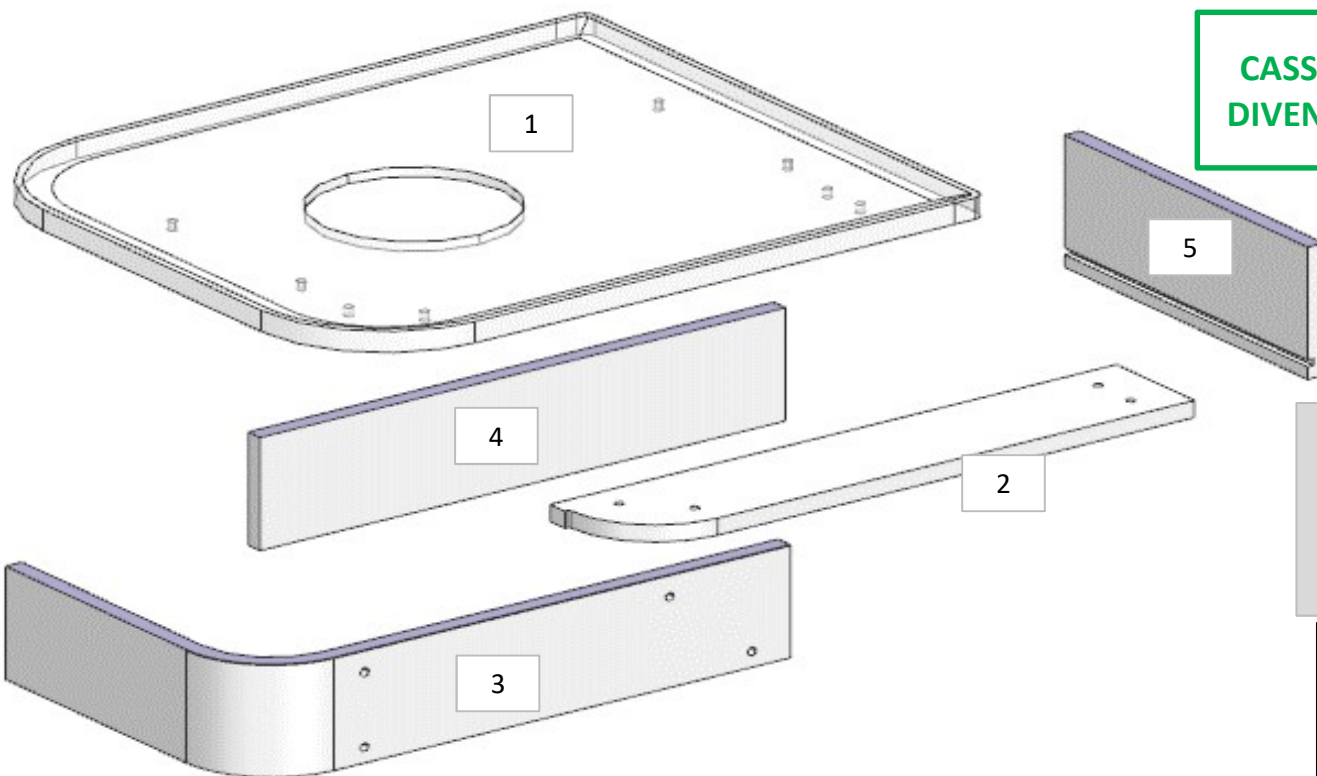

- 1 - L. 616 x H 530 x sp 20
- 2 - L. 544 x H 103 x sp 16
- 3 - L. 526 x H 320 x sp 16
- 4 - L. 510 x H 105 x sp 16
- 5 - L. 323 x H 123 x sp 16

**ELEMENTO DA MONTARE con:**  
**AI01\_02/03/04**  
**L01\_AI01\_02/03/04**  
e spedire con un unico imballo

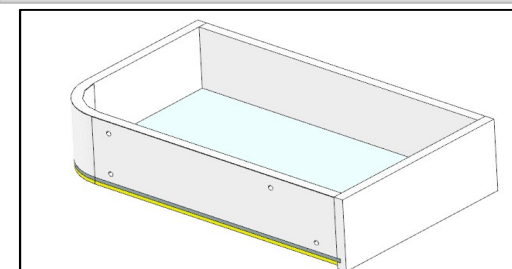

# AZ26M

MOD PTP

REV. GR 9

LOCALE	CODICE	DESCRIZIONE COMPONENTE	FINITURA	Q.TA	OPERATORE
CABINA ARMATORE	AZ26M-L02_AI01	COMODINO SX	LACCATO NCS S3020-Y30R	6	Damiano

1 - L. 685 x H 341 x sp 16  
2 - 6 - L. 50 x H 178 x sp 16  
3 - L. 100 x H 178 x sp 16  
4 - L. 623 x H 230 x sp 32  
5 - L. 188 x H 232 x sp 16

ELEMENTO DA MONTARE con:  
**L01\_AI01**  
**AZ26M-AI01\_01/02/03/04**  
e spedire con un unico imballo

**AGGIUNTO DENTELLI**

L01\_AI01  
AI01

consonni&c

# AZ26M

## MOD PTP

LOCALE	CODICE	DESCRIZIONE COMPONENTE	FINITURA	Q.TA	OPERATORE
CABINA ARMATORE	AZ26M-L01_AJ01	CIELINO INGRESSO	LACCATO BIANCO RAL 9016	6	Damiano

**ELIMINATI  
ATTENZIONE:  
PEZZI SOSTITUITI DA  
VETRORESINA  
DA GR 7**

**AGGIUNTO FORI  
FARETTI**

**DETTAGLIO**

- 1 - L. 30 x H 740 x sp 3
- 2 - L. 30 x H 34 x sp 3
- 3 - L. 788 x H 1096 x sp 10
- 4 - L. 562 x H 35 x 34
- 5 - L. 945 x H 38 x 34
- 6 - L. 34 x H 35 x sp 3

**consonni&c**

# AZ26M

MOD PTP

REV. GR 9

LOCALE	CODICE	DESCRIZIONE COMPONENTE	FINITURA	Q.TA	OPERATORE
CABINA ARMATORE	AZ26M-L01_AL01	COMODINO DX	LACCATO BIANCO RAL 9016	6	Damiano

**CASSETTO INTERNO  
DIVENTATO LACCATO**

- 1 - L. 895 x H 530 x sp 12
- 2 - L. 829 x H 103 x sp 16
- 3 - L. 805 x H 159 x sp 16
- 4 - L. 322 x H 177 x sp 16
- 5 - L. 291 x H 134 x sp 16
- 6 - L. 789 x H 159 x sp 16

**ELEMENTO DA MONTARE con:**  
**AL01\_02/03/04**  
**L01\_AL01\_03/04/05/06**  
e spedire con un unico imballo

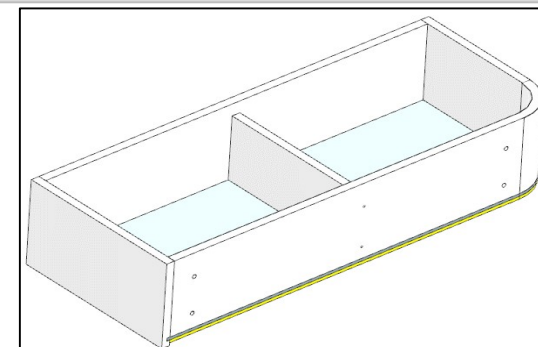
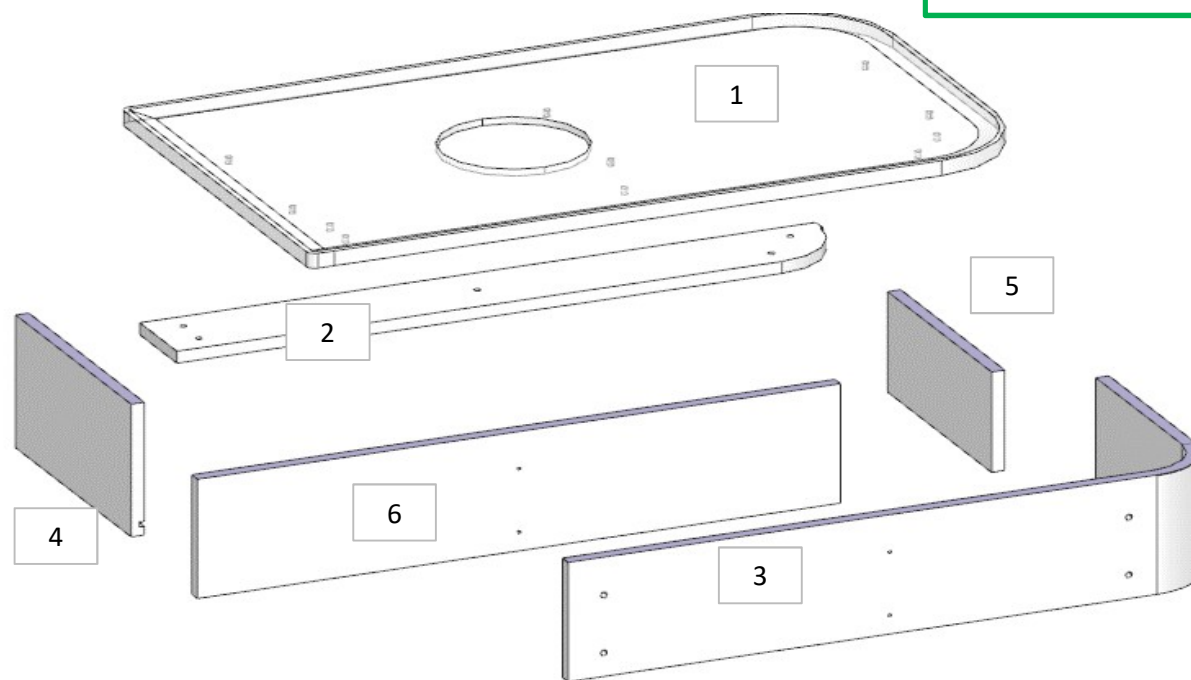

# AZ26M

MOD PTP

REV. GR 9

LOCALE	CODICE	DESCRIZIONE COMPONENTE	FINITURA	Q.TA	OPERATORE
CABINA ARMATORE	AZ26M-L02_AL01	COMODINO DX	LACCATO NCS S3020-Y30R	6	Damiano

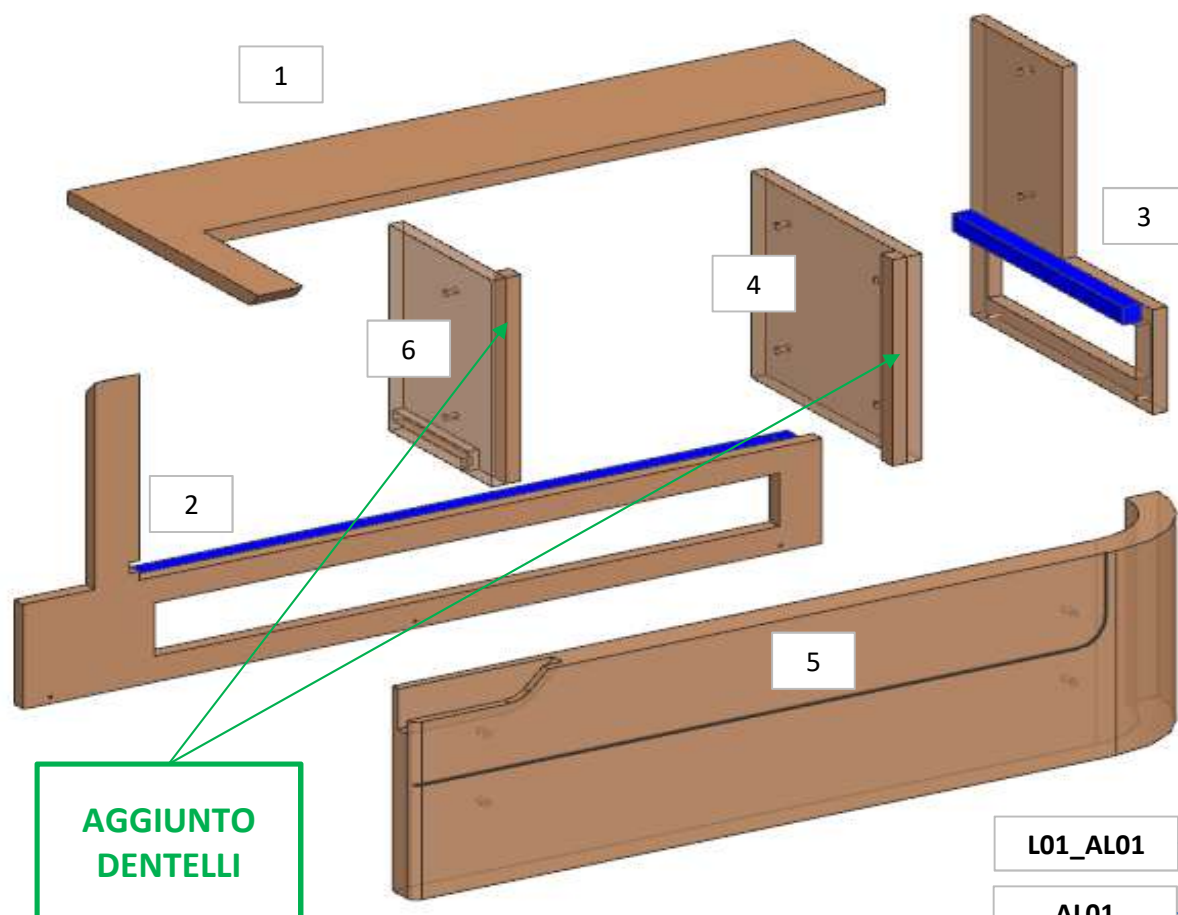

- 1 - L. 800 x H 341 x sp 16
- 2 - L. 880 x H 350 x sp 16
- 3 - L. 326 x H 334 x sp 16
- 4 - L. 279 x H 232 x sp 16
- 5 - SVILUPPO L. 991 x H 230 x sp 32
- 6 - L. 188 x H 232 x sp 16

**ELEMENTO DA MONTARE con:**  
**L01\_AL01**  
**AL01**  
 e spedire con un unico imballo

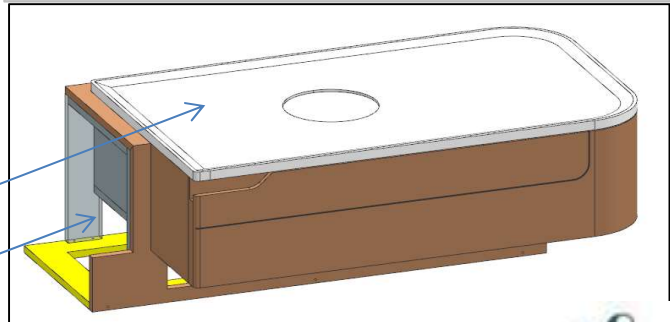

**AGGIUNTO  
DENTELLI**

L01\_AL01

AL01

# AZ26M

REV. GR 9

LOCALE	CODICE	DESCRIZIONE COMPONENTE	FINITURA	Q.TA	OPERATORE
CABINA ARMATORE	AZ26M-L01_AM01	LETTO	LACCATO NCS S3020-Y30R	3	Damiano

- 1 - L. 1565 x H 257 x sp 16
- 2 - L. 1313 x H 110 x sp 16
- 3 - L. 1686 x H 257 x sp 16

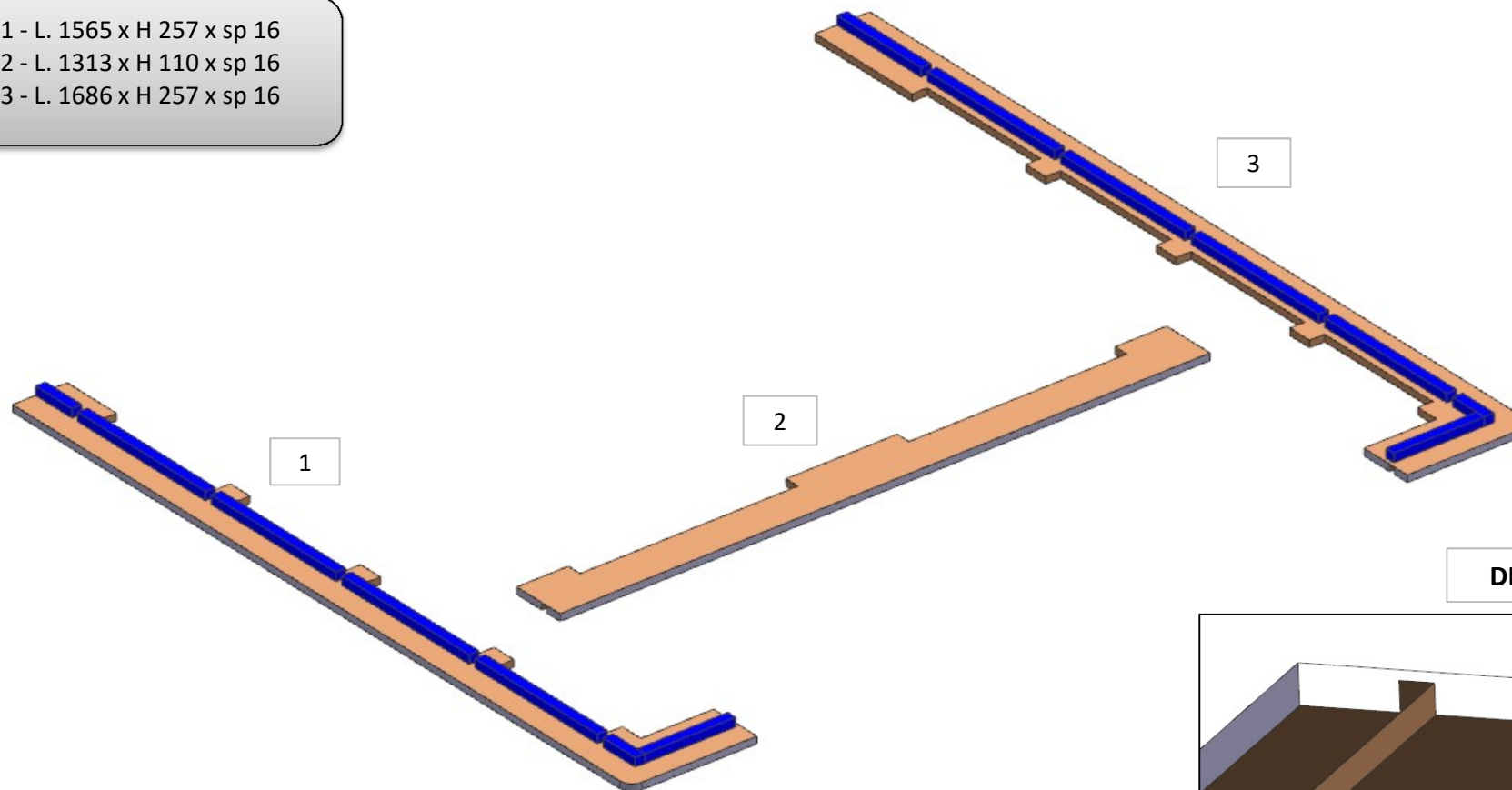

DETTAGLIO

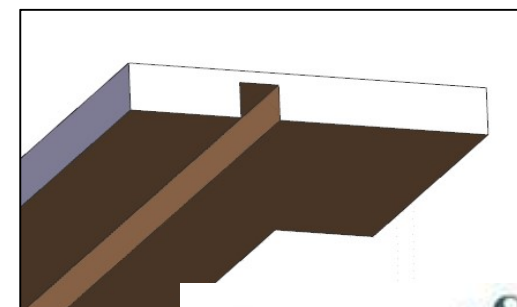

consonni&c

# AZ26M

MOD DA GR10

REV. GR 10

LOCALE	CODICE	DESCRIZIONE COMPONENTE	FINITURA	Q.TA	OPERATORE
CABINA ARMATORE	AZ26M-L01_AO01	MONTANTE DI COLLEGAMENTO MURATE	LACCATO BIANCO RAL 9010	1	Damiano

**MOD INTERNA 42  
UNUCO PEZZO UN LARICROS**

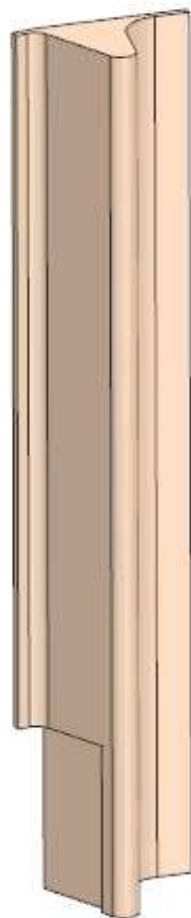

**ELEMENTO DA MONTARE con:  
X01\_AO01  
e spedire con un unico imballo**

X01\_AO01

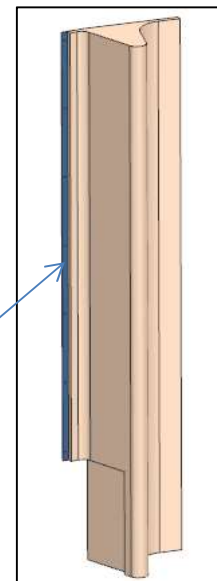

# AZ26M

REV. GR 9

LOCALE	CODICE	DESCRIZIONE COMPONENTE	FINITURA	Q.TA	OPERATORE
CABINA ARMATORE	AZ26M-L01_AP01	MURATA DX PRUA	LACCATO BIANCO RAL 9010	4	Damiano

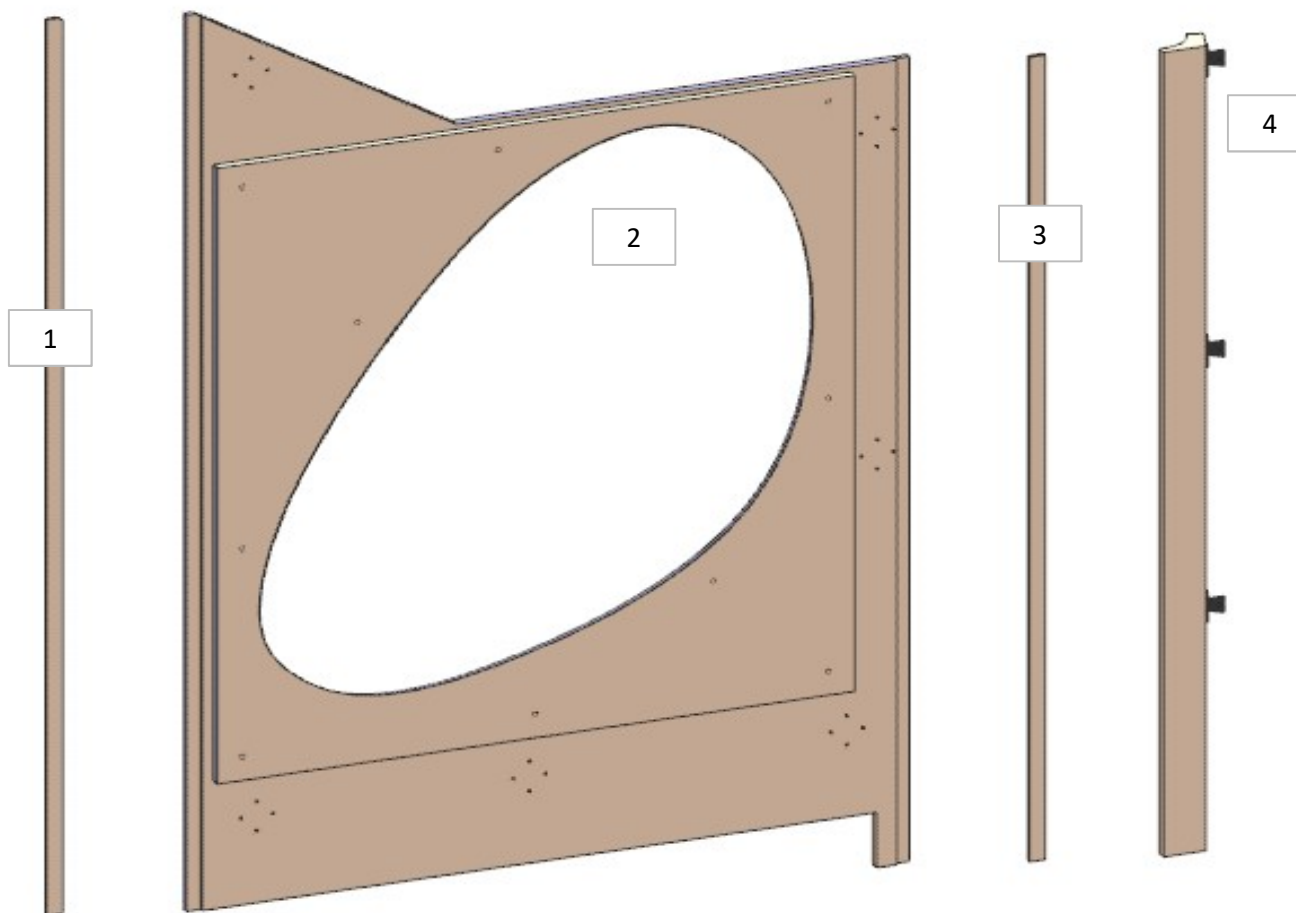

- 1 - L. 25 x H 1542 x sp 5,5
- 2 - L. 1132 x H 1637 x sp 16
- 3 - L. 25 x H 1385 x sp 6
- 4 - L. 66 x H 1385 x 53

**ELEMENTO DA MONTARE:**  
**MG\_AP01**  
 e spedire con un unico imballo

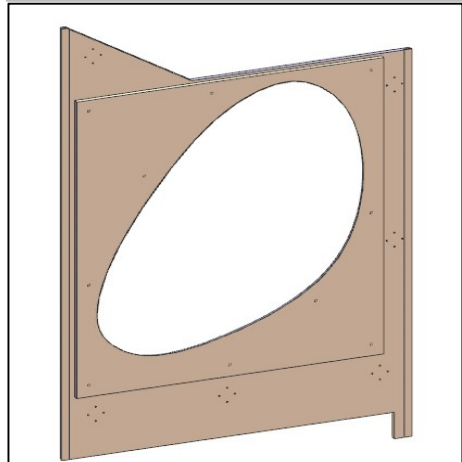

# AZ26M

REV. GR 9

LOCALE	CODICE	DESCRIZIONE COMPONENTE	FINITURA	Q.TA	OPERATORE
CABINA ARMATORE	AZ26M-L02_AP01	MURATA DX PRUA	LACCATO BRONZO	6	Damiano

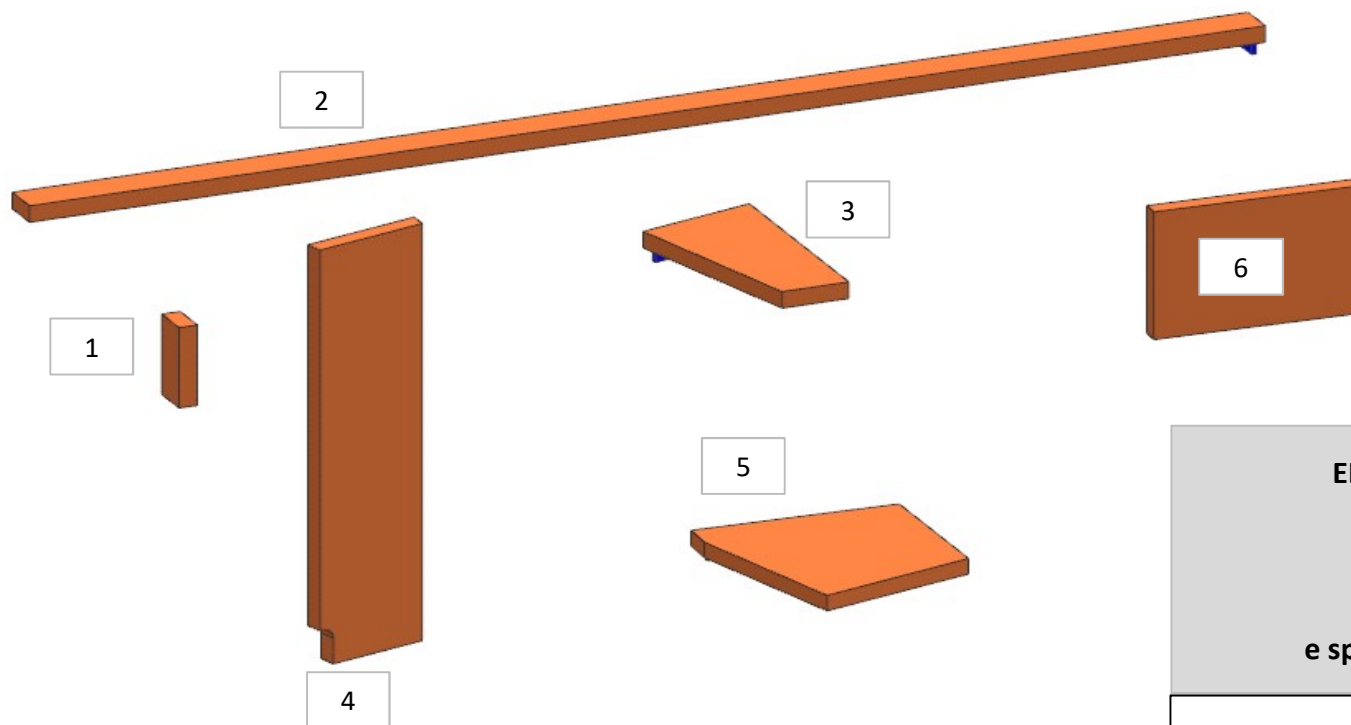

- 1 - L. 35 x H 77,5 x sp 16
- 2 - L. 1081 x H 35 x sp 16
- 3 - L. 202 x H 108 x sp 16
- 4 - L. 108 x H 401 x sp 16
- 5 - L. 183 x H 178 x sp 15
- 6 - L. 178 x H 123 x sp 16

**ELEMENTO DA MONTARE:**  
**MG\_AP02**  
**MG\_AP03**  
**MG\_AP04**  
 e spedire con un unico imballo

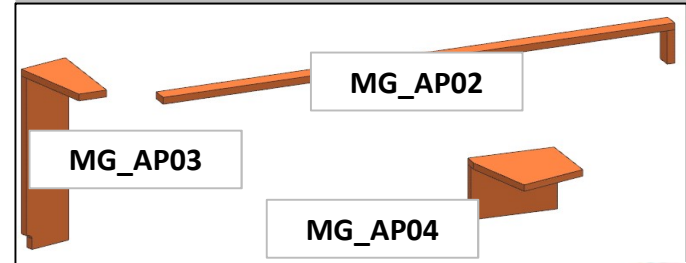

# AZ26M

REV. GR 9

LOCALE	CODICE	DESCRIZIONE COMPONENTE	FINITURA	Q.TA	OPERATORE
CABINA ARMATORE	AZ26M-L01_AR01	PLENUM ARMADIO PRUA STD-VAR1	LACCATO BRONZO\ GREZZO VERNICIATO	1	Damiano

1 - L 795 x H 164 x sp 16

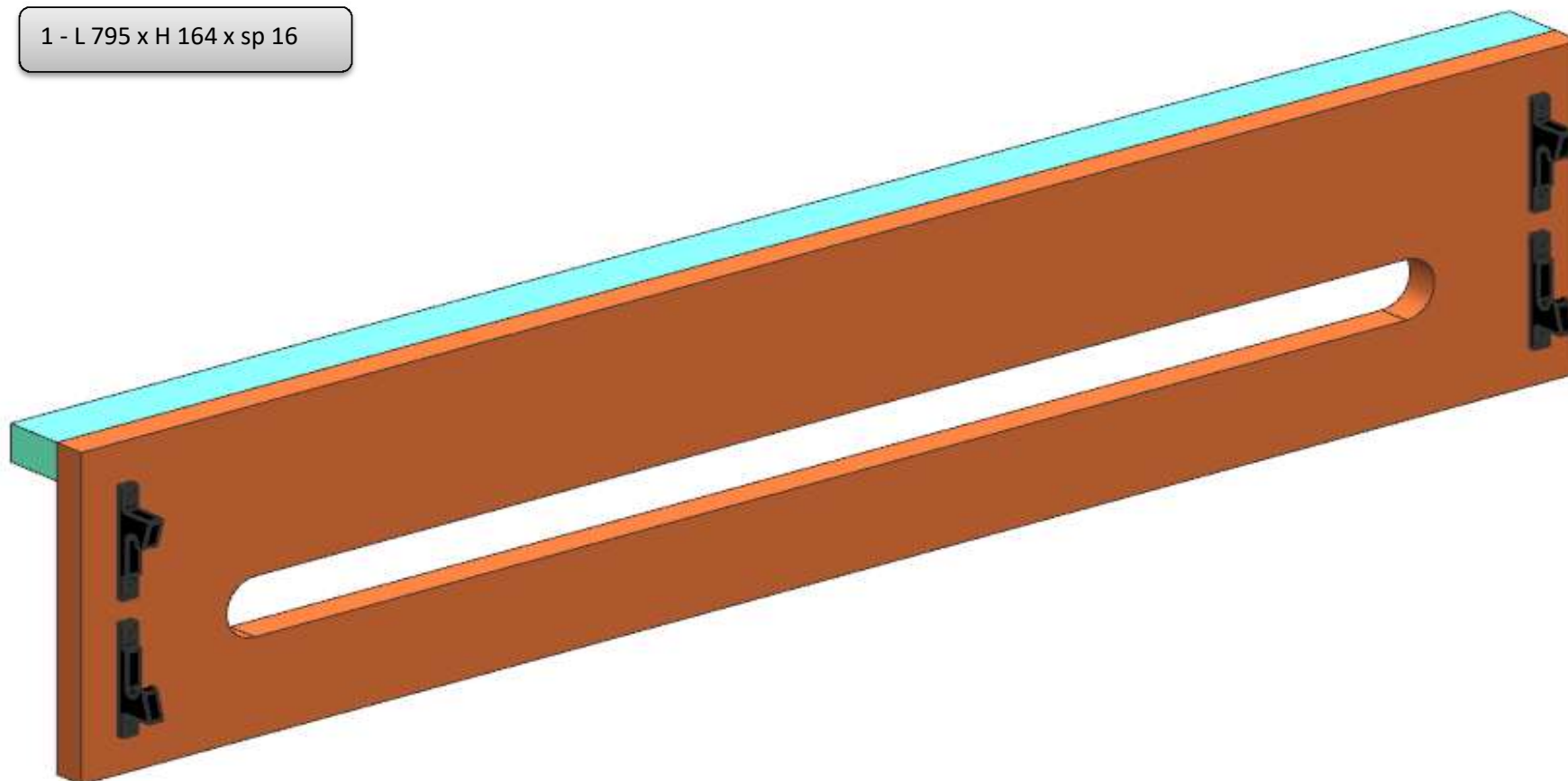

consonni&c

# AZ26M

REV. 01-2023

REV. GR 9

LOCALE	CODICE	DESCRIZIONE COMPONENTE	FINITURA	Q.TA	OPERATORE
CABINA ARMATORE	AZ26M-L01_AS01	ARMADIO DRESSING MURATA DI PRUA	LACCATO BIANCO RAL 9010	3	Damiano

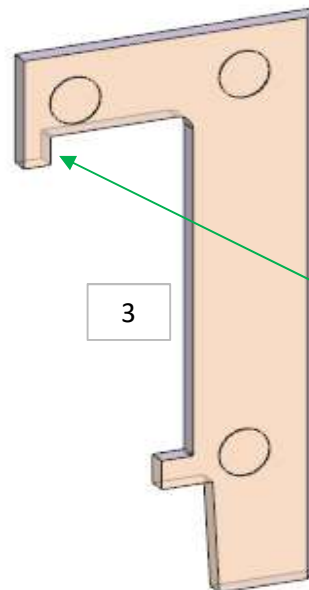
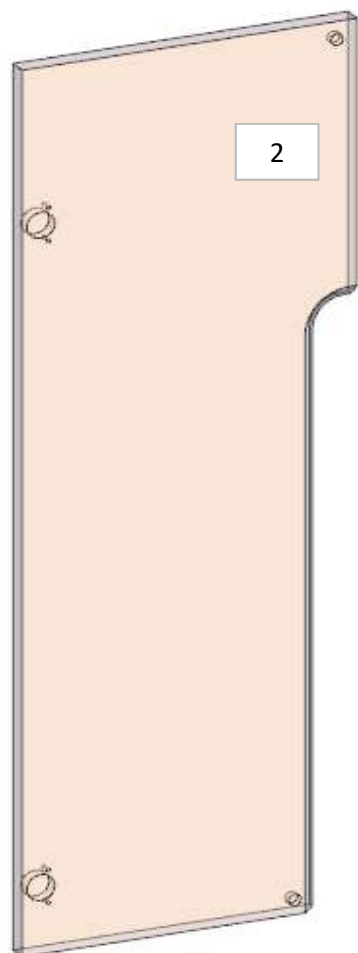

- 1 - L. 420 x H 30 x sp 25
- 2 - L. 420 x H 1204 x sp 25
- 3 - L. 372 x H 762 x sp 25

**ATTENZIONE:  
SPINARE MA NON  
INCOLLARE**

**AGGIUNTO  
DENTELLO**

# AZ26M

REV. GR 9

LOCALE	CODICE	DESCRIZIONE COMPONENTE	FINITURA	Q.TA	OPERATORE
CABINA ARMATORE	AZ26M-L01_AT01	CASSETTIERA DRESSING PRUA	LACCATO BIANCO RAL 9010	2	Damiano

2 - L. 1310 x H 190 x 31

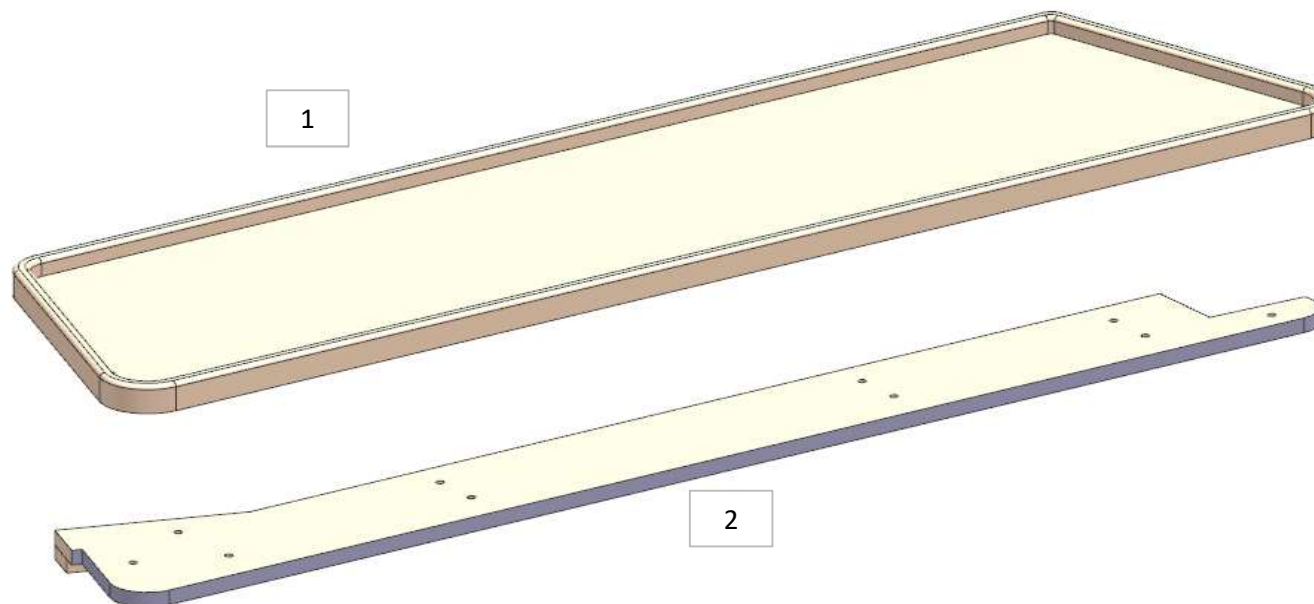

**consonni&c**

# AZ26M

REV. GR 9

LOCALE	CODICE	DESCRIZIONE COMPONENTE	FINITURA	Q.TA	OPERATORE
CABINA ARMATORE	AZ26M-L02_AT01_01	CASSETTIERA DRESSING PRUA	LACCATO BRONZO	1	Damiano

1 - 2 - 3 - DIAMETRO 20 x L 380

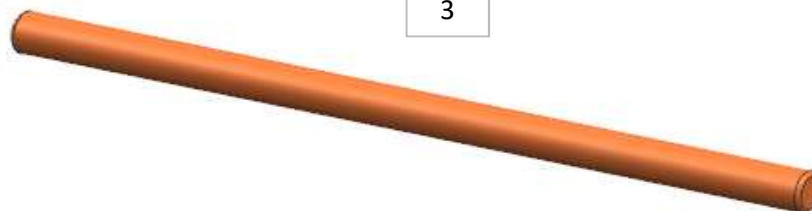
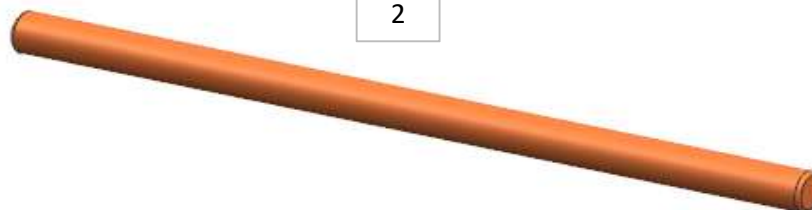

consonni&c

# AZ26M

REV. GR 9

LOCALE	CODICE	DESCRIZIONE COMPONENTE	FINITURA	Q.TA	OPERATORE
CABINA ARMATORE	AZ26M-L01_AU01	PLENUM MURATA SX POPPA	LACCATO BRONZO	1	Damiano

1 - L. 1950 x H 96 x 28



# AZ26M

REV. GR 9

LOCALE	CODICE	DESCRIZIONE COMPONENTE	FINITURA	Q.TA	OPERATORE
CABINA ARMATORE	AZ26M-L01_AV01	PLENUM MURATA DX POPPA	LACCATO BRONZO	1	Damiano

1 - L. 1242 x H 96 x 28

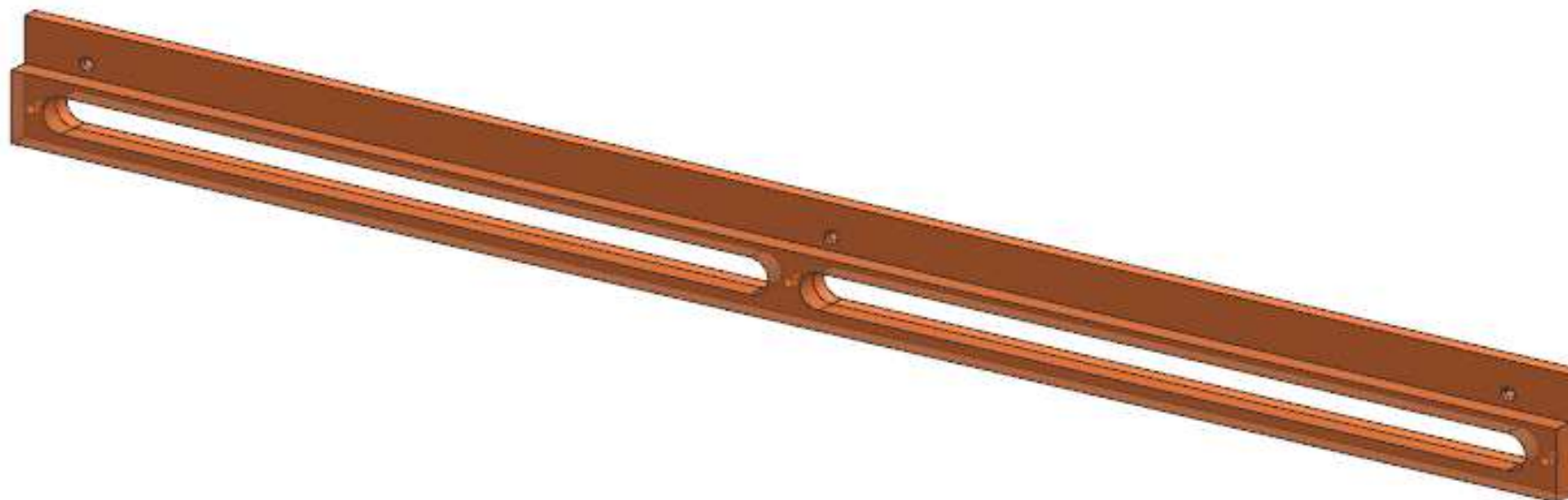

consonni&c

# AZ26M

MOD PTP

REV. GR 9

LOCALE	CODICE	DESCRIZIONE COMPONENTE	FINITURA	Q.TA	OPERATORE
CABINA ARMATORE	AZ26M-L01_AW01	CIELINO MURATA PRUA DX	LACCATO BIANCO RAL 9016	2	Damiano

- 1 - L. 1242 x H 455 x sp 10
- 2 - L. 686 x H 1153 x sp 10

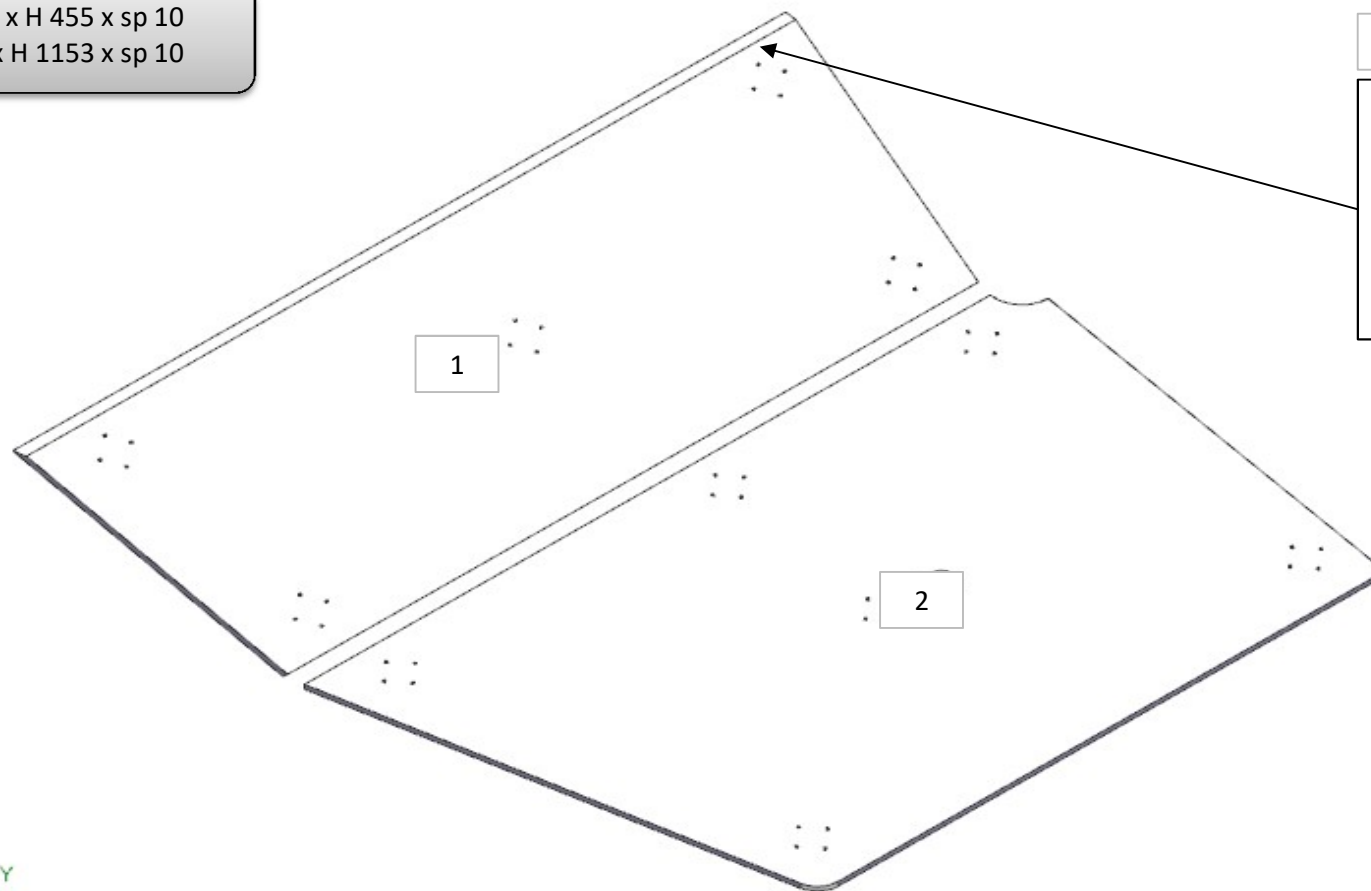

AGGIUNTO  
FORO FARETTO

# AZ26M

MOD GR4

LOCALE	CODICE	DESCRIZIONE COMPONENTE	FINITURA	Q.TA	OPERATORE
CABINA ARMATORE	AZ26M-L01_AZ01	CIELINO PARTE CENTRALE	LACCATO BIANCO RAL 9016	5	Damiano

- 1 - L. 703 x H 242 x sp 10
- 2 - L. 710 x H 273 x sp 10
- 3 - L. 1115 x H 49
- 4 - L. 36 x H 11 x
- 5 - L. 1121 x H 32

**ELIMINATI  
ATTENZIONE:  
PEZZI SOSTITUITI DA  
VETRORESINA  
DA GR 7**

5

# AZ26M

REV. GR 9

LOCALE	CODICE	DESCRIZIONE COMPONENTE	FINITURA	Q.TA	OPERATORE
CABINA ARMATORE	AZ26M-L01_AAR01	PLENUM ARMADIO PRUA STD-VAR2	LACCATO BRONZO\ GREZZO VERNICIATO ANTI	1	Damiano

1 - L.795 x H 144 x sp 16

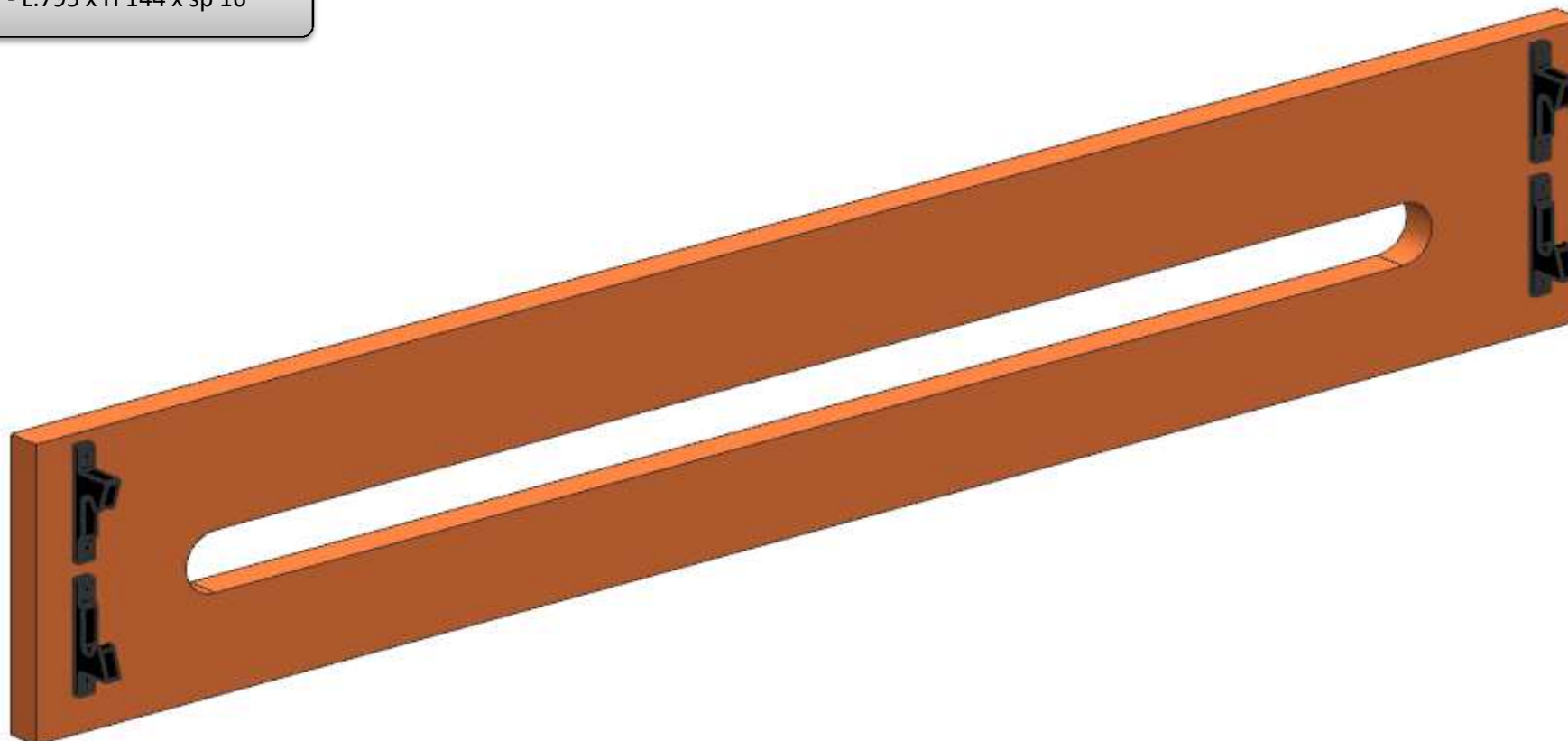

consonni&c

# AZ26M

REV. GR 9

LOCALE	CODICE	DESCRIZIONE COMPONENTE	FINITURA	Q.TA	OPERATORE
CABINA ARMATORE	AZ26M-L01_AAS01	PORTAGIOIE COMODINO SX		3	Damiano

- 1 - DIAMETRO 170 x H 19
- 2 - DIAMETRO 170 x H 39
- 3 - DIAMETRO 158 x H 6

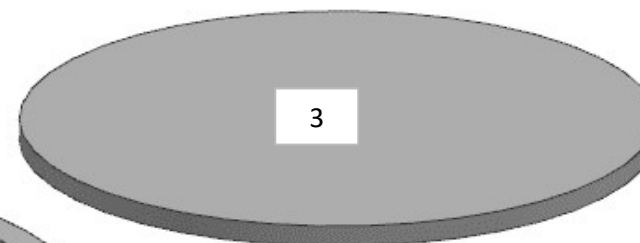
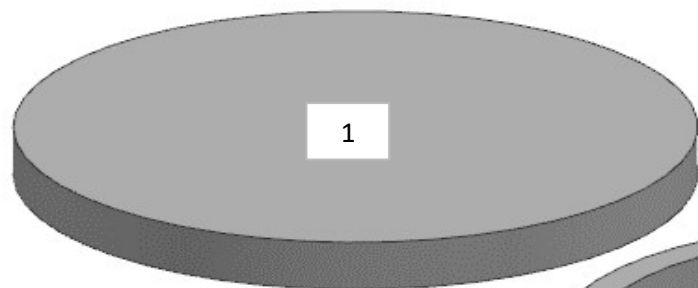

**ELEMENTO DA MONTARE:  
MG\_AAS01  
e spedire con un unico imballo**

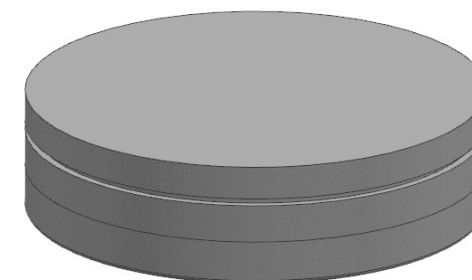

**CAPRI:** GIALLO- RAL 1004 100 gloss  
**RIVIERA:** ACQUAMARINA - NCS S2030-B50G 100 gloss  
**NEUTRO** - LACCATO BRONZO DA CAMPIONE

**consonni&c**

# AZ26M

REV. GR 9

LOCALE	CODICE	DESCRIZIONE COMPONENTE	FINITURA	Q.TA	OPERATORE
CABINA ARMATORE	AZ26M-L01_AAT01	PORTAGIOIE COMODINO DX		3	Damiano

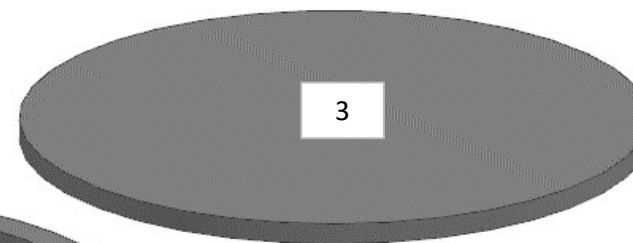
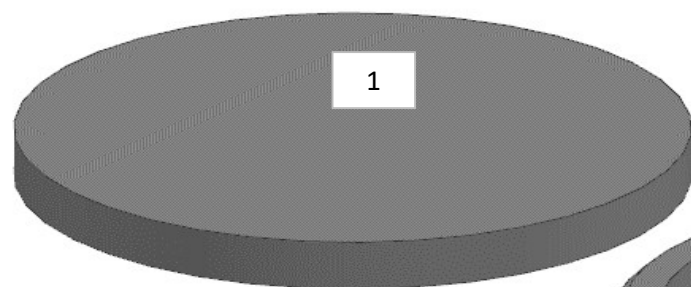

- 1 - DIAMETRO 170 x H 19
- 2 - DIAMETRO 170 x H 39
- 3 - DIAMETRO 158 x H 6

**ELEMENTO DA MONTARE:  
MG\_AAT01  
e spedire con un unico imballo**

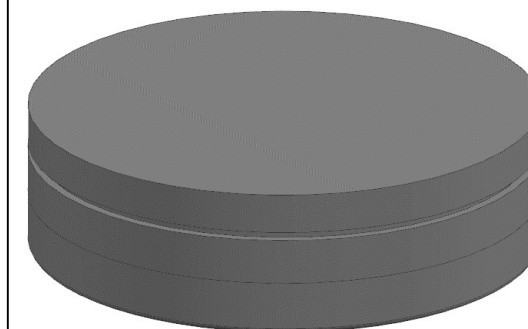

**CAPRI:** BLU- NCS S4050-R70B 100 gloss  
**RIVIERA:** ACQUAMARINA - NCS S2030-B50G 100 gloss  
**NEUTRO** - LACCATO BRONZO DA CAMPIONE

**consonni&c**

# AZ26M

DA MAT 12

REV. GR 9

LOCALE	CODICE	DESCRIZIONE COMPONENTE	FINITURA	Q.TA	OPERATORE
CABINA ARMATORE	AZ26M-L01_AAU01	SCRIVANIA VANITY	LACCATO LUMEN NCS S0502-Y	1	Damiano

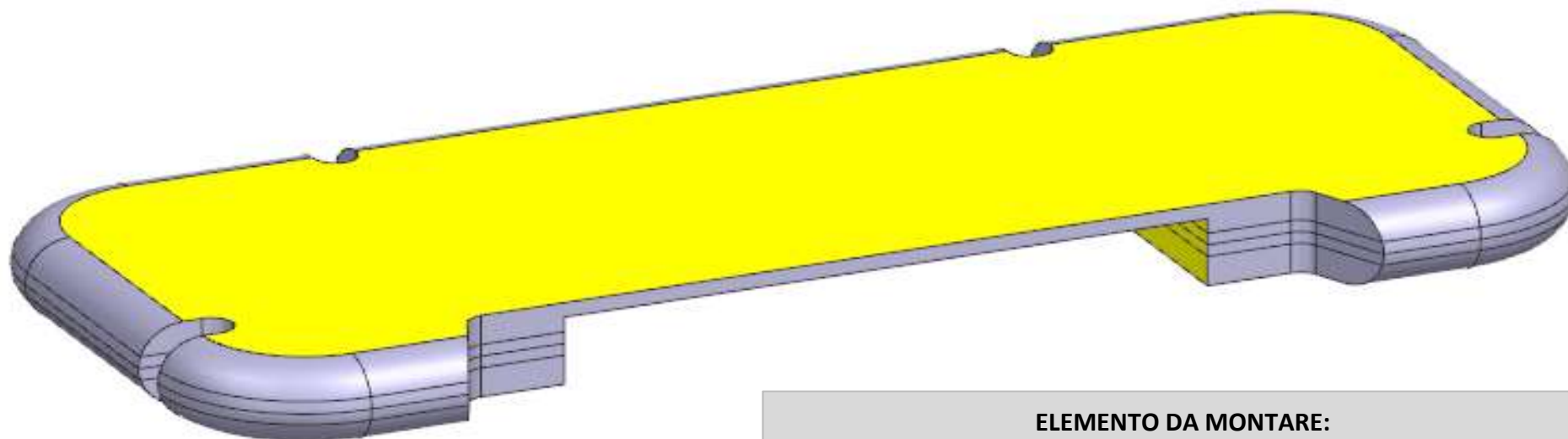

**ELEMENTO DA MONTARE:**  
**L02\_AAU01**  
e spedire con un unico imballo

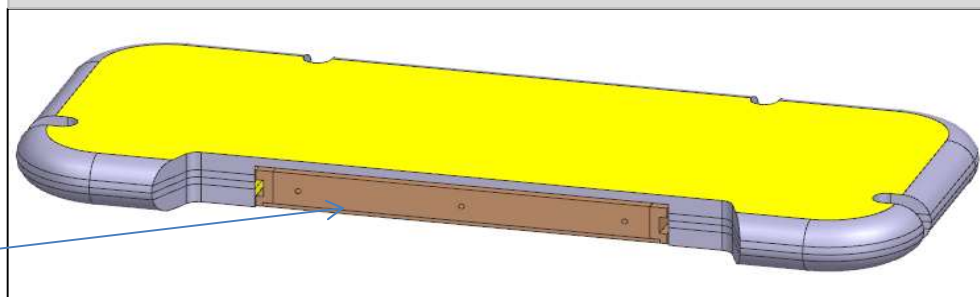

**FERRAMENTA:**

N° 2 - CALAMITE PER CASSETTI  
N° 2 - GUIDE ACCURRIDE 250  
codice 322683  
BUSSOLA ZAMA

L02\_AAU01

# AZ26M

DA MAT 12

REV. GR 9

LOCALE	CODICE	DESCRIZIONE COMPONENTE	FINITURA	Q.TA	OPERATORE
CABINA ARMATORE	AZ26M-L02_AAU01	SCRIVANIA VANITY	LACCATO NCS S3020-Y30R	5	Damiano

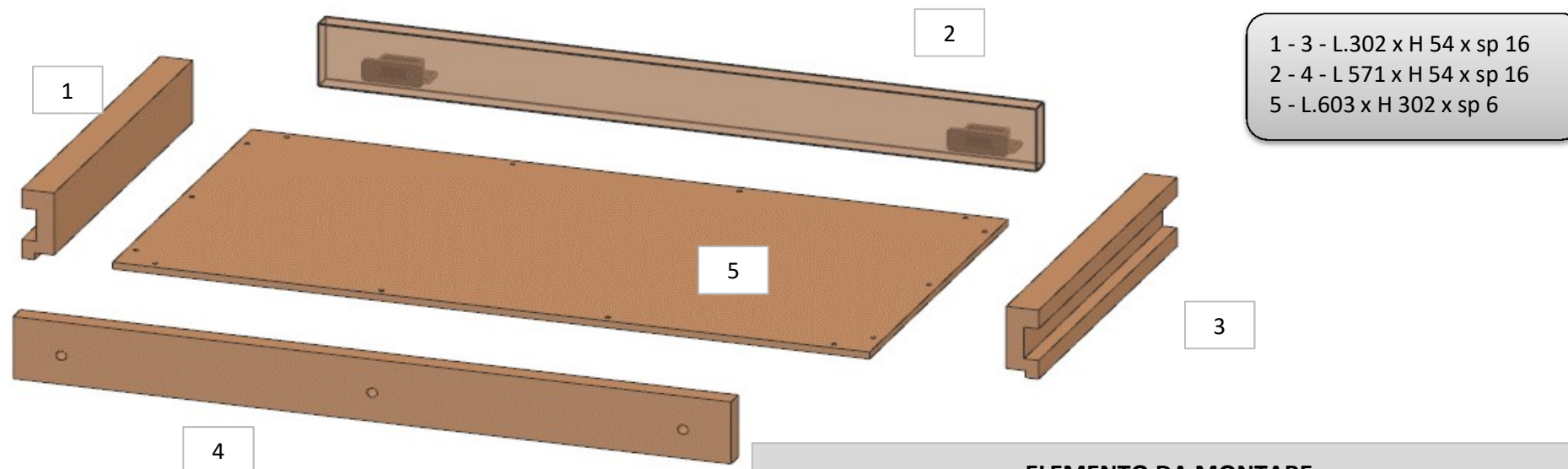

1 - 3 - L.302 x H 54 x sp 16  
 2 - 4 - L 571 x H 54 x sp 16  
 5 - L.603 x H 302 x sp 6

**ELEMENTO DA MONTARE:**  
**L01\_AAU01**  
 e spedire con un unico imballo

ALLARGATO FRESATE PER LE GUIDE  
 - AGGIUNTO FORI AL FONDO DEL  
 CASSETTO

L01\_AAU01

