

# AZ26M

REV. GR 9

LOCALE	CODICE	DESCRIZIONE COMPONENTE	FINITURA	Q.TA	OPERATORE
SALONE	AZ26M-A01_SF01	STRUTTURA MURATA SX PRUA	ACCIAIO	1	Damiano



ELEMENTO DA MONTARE con:  
**X01\_SF01**  
**L01\_SF01**  
e spedire con un unico imballo

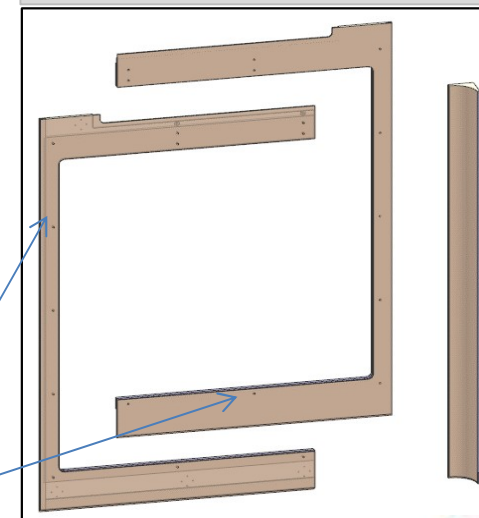

1 - L.60 x H 2036 x sp 1

X01\_SF01

L01\_SF01

# AZ26M

DA PTP

REV. GR 9

LOCALE	CODICE	DESCRIZIONE COMPONENTE	FINITURA	Q.TA	OPERATORE
SALONE	AZ26M-A01_SJ01	TAVOLO SALONE	ACCIAIO	7	Damiano

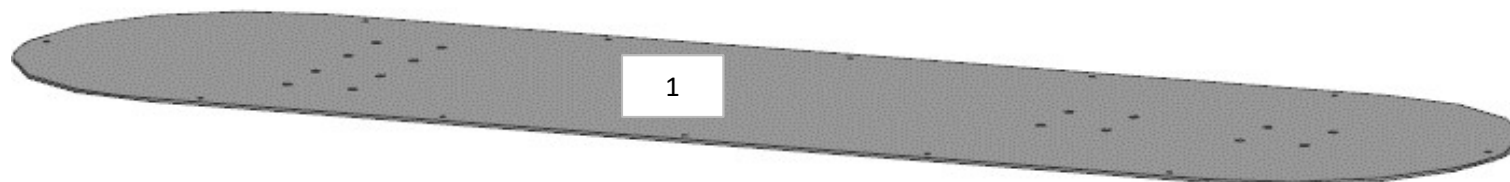

1

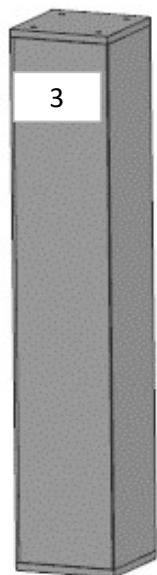

3

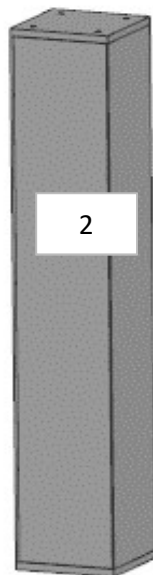

2



4

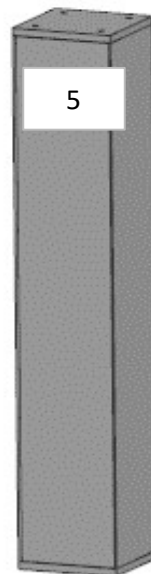

5

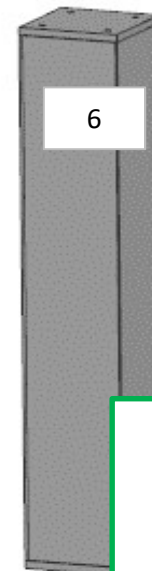

6



7

**MOD INT 38**  
MODIFICATI CODICI  
LASTRA 02-03-04-05 E  
MODIFICATO PIASTRE

**consonni&c**

# AZ26M

DA GR9

REV. GR 9

LOCALE	CODICE	DESCRIZIONE COMPONENTE	FINITURA	Q.TA	OPERATORE
SALONE	AZ26M-A01_SK01	COFFEE TABLE	ACCIAIO	2	Damiano

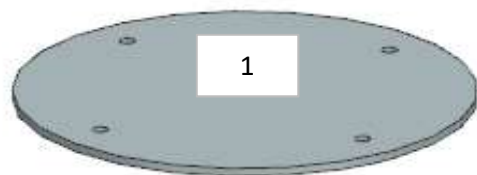

ELEMENTO DA MONTARE con:  
**L01\_SK01**  
e spedire con un unico imballo

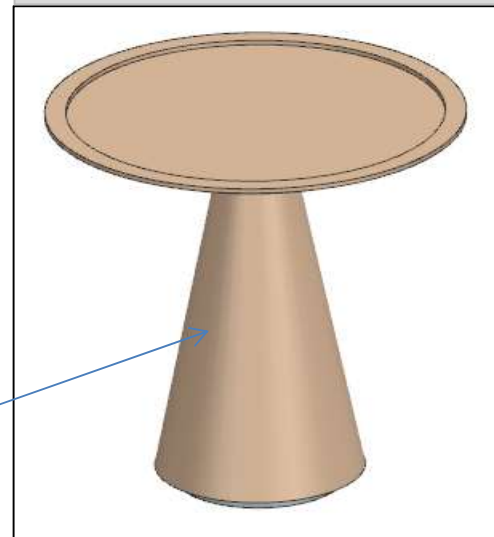

# AZ26M

REV. GR 9

LOCALE	CODICE	DESCRIZIONE COMPONENTE	FINITURA	Q.TA	OPERATORE
SALONE	AZ26M-A01_SV01	STRUTT. SPESSORAMENTO RIV. PRUA	ACCIAIO	1	Damiano

1 - L.2192 x H 60 x sp 2



# AZ26M

REV. 01-2023

REV. GR 9

LOCALE	CODICE	DESCRIZIONE COMPONENTE	FINITURA	Q.TA	OPERATORE
SALONE	AZ26M-A01_SW01	RIV. PARETE PASSAVIVANDE	ACCIAIO	6	Damiano

1 - 2 - L.2036 x H 60 x sp 1  
3 - 5 - L 850 x H 30 x 30  
4 - 6 - L 432 x H 30 x 30

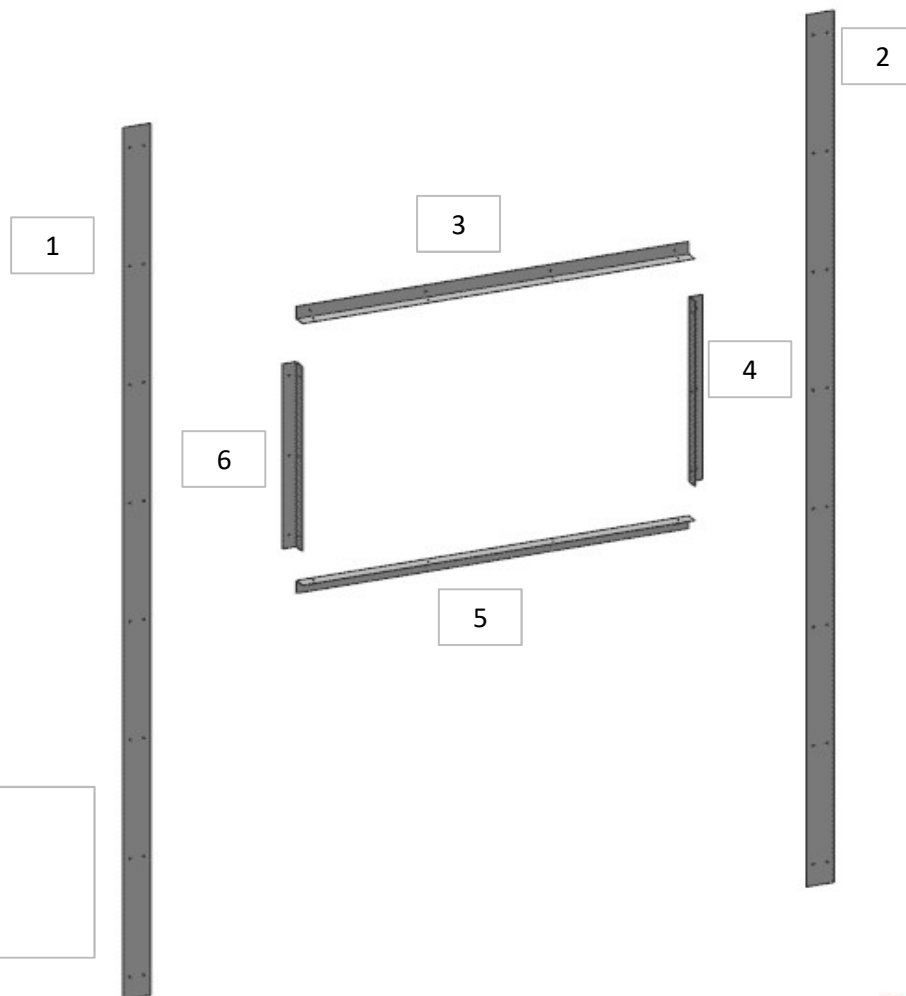

## FERRAMENTA:

ML 2,7 - PIATTINA ANGOLARE PREFORATA sp 1mm  
ML 4 - PIATTINE IN ACCIAIO PREFORATO sp 1mm