

AZ26M

REV. GR 9

LOCALE	CODICE	DESCRIZIONE COMPONENTE	FINITURA	Q.TA	OPERATORE
CABINA OSPITI SX	AZ26M-A01_LA01	ARMADIO	ACCIAIO NERO	3	Damiano

- 1 - L 712 x H.5 x sp 2
- 2 - L 89 x H.44 x sp 5
- 3 - L 540 x H.5 x sp 2

ELEMENTO DA
MONTARE con:
R01_LA01
LA01
e spedire con un
unico imballo

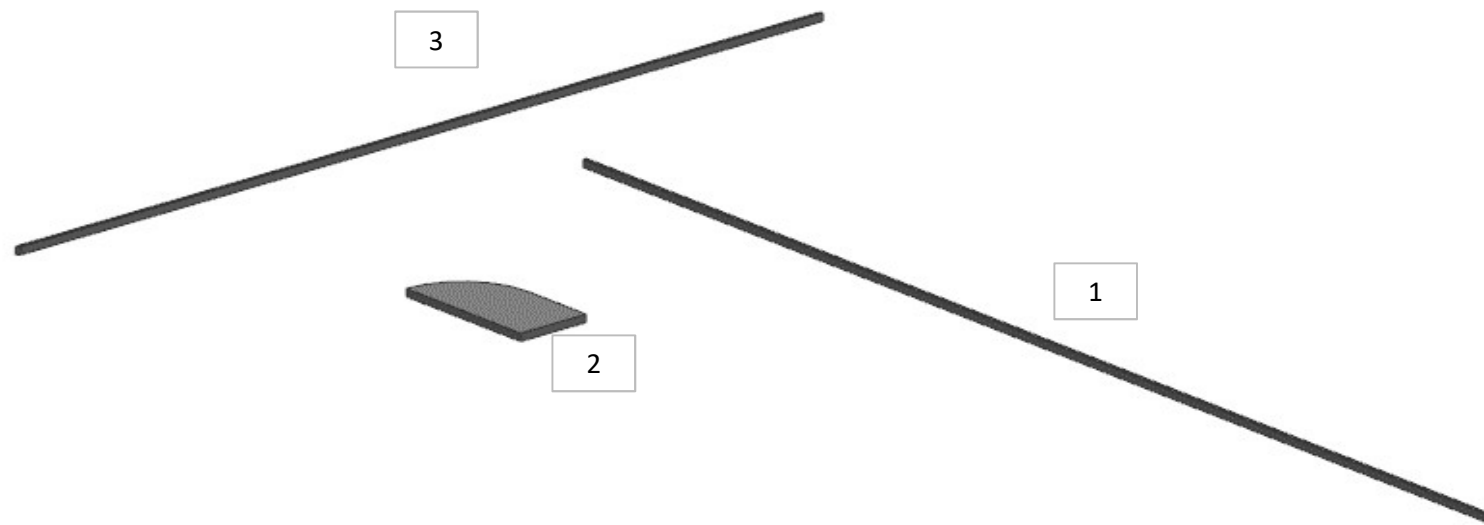

R01_LA01
LA01

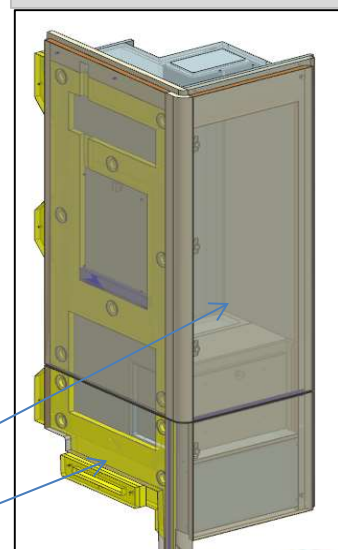

AZ26M

REV. GR 9

LOCALE	CODICE	DESCRIZIONE COMPONENTE	FINITURA	Q.TA	OPERATORE
CABINA OSPITI SX	AZ26M-A01_LF01	RIVESTIMENTI PARETI CENTRO NAVE	ALLUMINIO	4	Damiano

1 - 2 - L.50 x H 1339 x sp 2
3 - 4 - L.50 x H 509 x sp 2

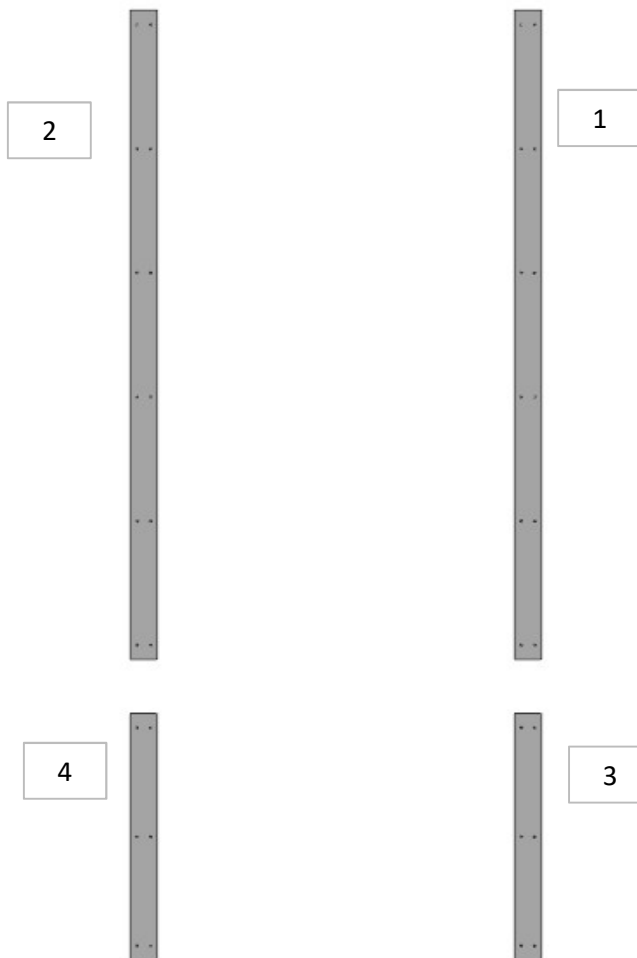

ELEMENTO DA MONTARE
con:
R01_LF01
e spedire con un unico
imballo

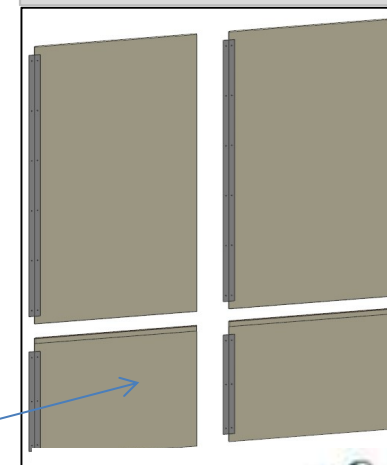

R01_LF01

consonni&c

AZ26M

DA MAT. 14

REV. GR 9

LOCALE	CODICE	DESCRIZIONE COMPONENTE	FINITURA	Q.TA	OPERATORE
CABINA OSPITI SX	AZ26M-A02_LF01	RIVESTIMENTI PARETI CENTRO NAVE	ACCIAIO NERO	1	Damiano

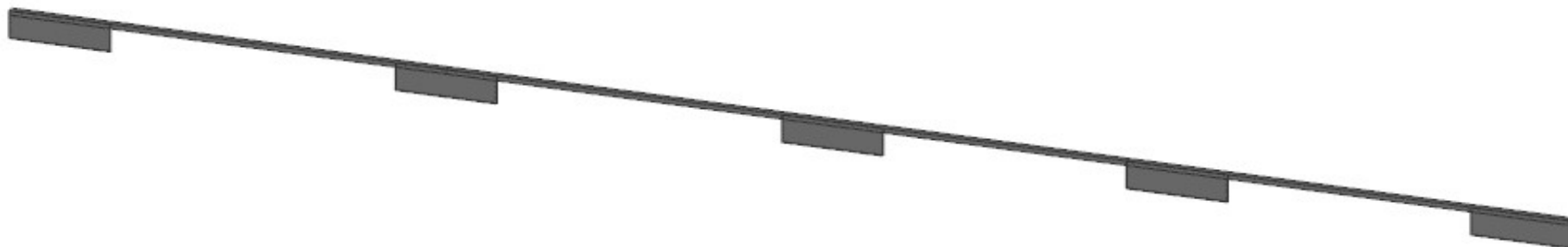

AZ26M

REV. GR 9

LOCALE	CODICE	DESCRIZIONE COMPONENTE	FINITURA	Q.TA	OPERATORE
CABINA OSPITI SX	AZ26M-A01_LG01	LETTO MURATA	ACCIAIO	1	Damiano

1 - L 50 x H 145 x sp 3



AZ26M

REV. GR 9

LOCALE	CODICE	DESCRIZIONE COMPONENTE	FINITURA	Q.TA	OPERATORE
CABINA OSPITI SX	AZ26M-A01_LH01	LETTO CENTRO NAVE	ACCIAIO	2	Damiano

1 - 2 - L 50 x H 145 x sp 3

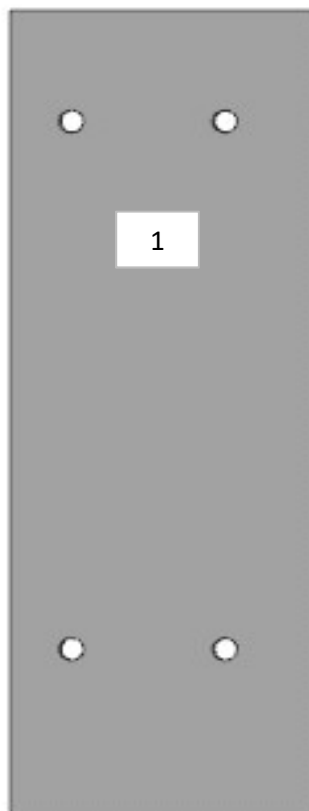

AZ26M

REV. GR 9

LOCALE	CODICE	DESCRIZIONE COMPONENTE	FINITURA	Q.TA	OPERATORE
CABINA OSPITI SX	AZ26M-A01_LL01	RIVESTIMENTI PARETI PRUA	ACCIAIO NERO	2	Damiano

1 - L. 315 x H.30 x sp 8
2 - L. 186 x H.30 x sp 8

RIDOTTO LARGHEZZA PZ. 2

1



2



AZ26M

DA MAT. 11

REV. GR 9

LOCALE	CODICE	DESCRIZIONE COMPONENTE	FINITURA	Q.TA	OPERATORE
CABINA OSPITI SX	AZ26M-A01_LP01	LETTO PULLMAN - OPT	ACCIAIO	7	Damiano

