

AZ26M

MOD DA GR10

REV. GR 10

LOCALE	CODICE	DESCRIZIONE COMPONENTE	FINITURA	Q.TA	OPERATORE
CABINA VIP DX	AZ26M-I01_VA01	STRUTTURA MURATA TESTATA LETTO	OKOUME' GREZZO	7	Dante

- 1 - 7 - L 239 x H 756 x sp 200
- 2 - 6 - SVILUPPO L 177 x H 619 x sp 25
- 3 - 5 L 266 x H 619 x sp 25
- 4 - L 1781 x H 619 x sp 25

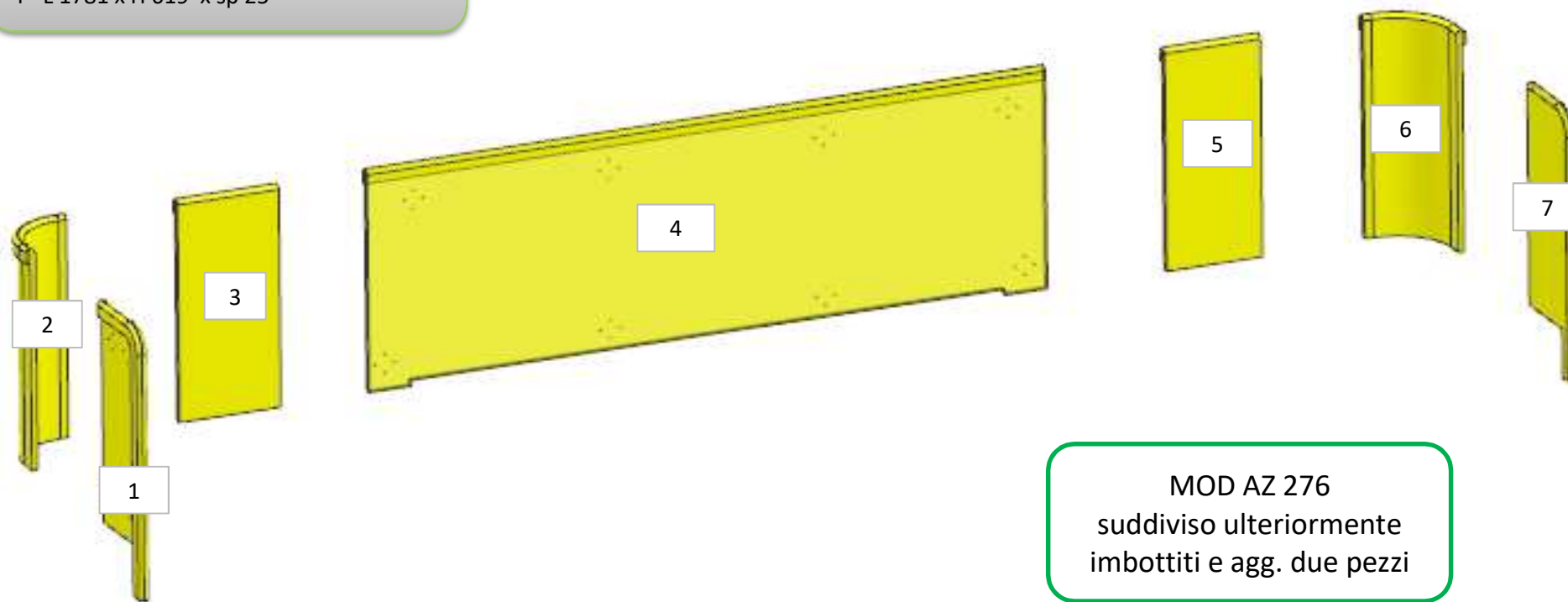

AZ26M

REV. GR 9

LOCALE	CODICE	DESCRIZIONE COMPONENTE	FINITURA	Q.TA	OPERATORE
CABINA VIP DX	AZ26M-I01_VC01	STRUTTURA LETTO	GREZZO SPRUZZATO ANTIMUFFA COLORATO	3	Dante

1 - 3 - L 1705 x H 200 x sp 19
2 - SVILUPPO L 1920 x H 200 x sp 19

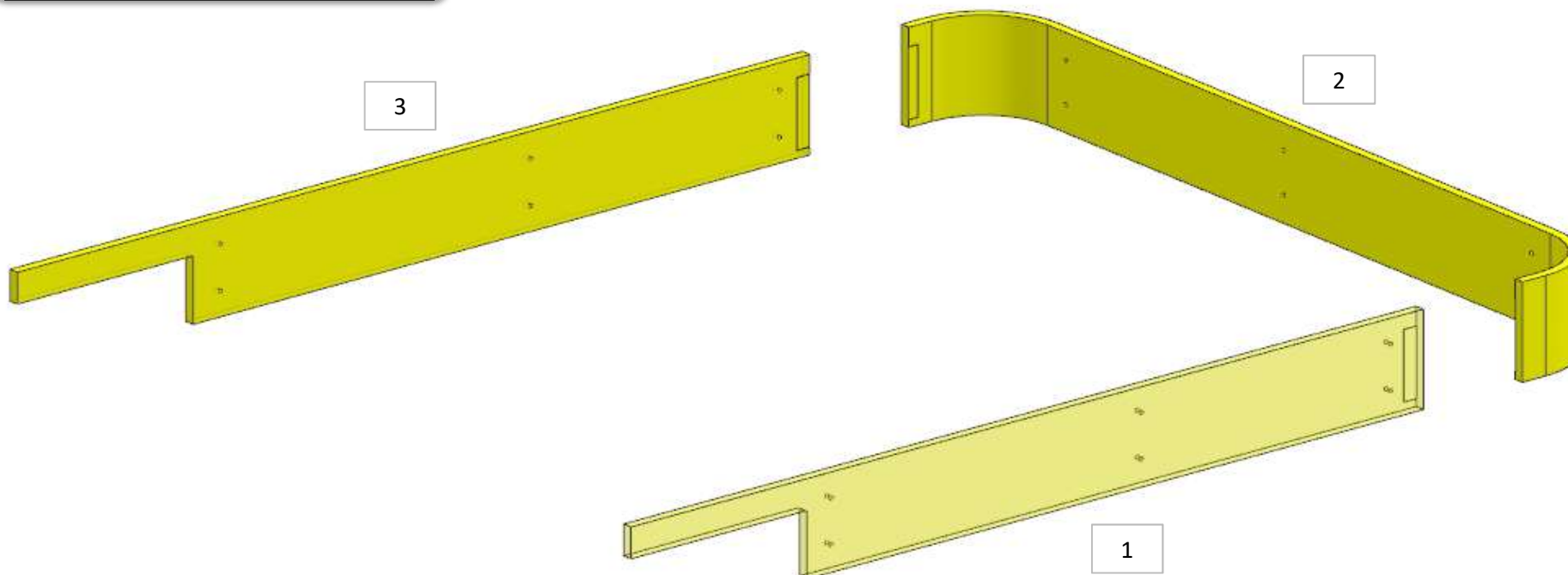

AZ26M

REV. 01-2023

REV. GR 10

LOCALE	CODICE	DESCRIZIONE COMPONENTE	FINITURA	Q.TA	OPERATORE
CABINA VIP SX	AZ26M-I01_VVA01	STRUTTURA MURATA TESTATA LETTO	OKOUME' GREZZO	5	Damiano

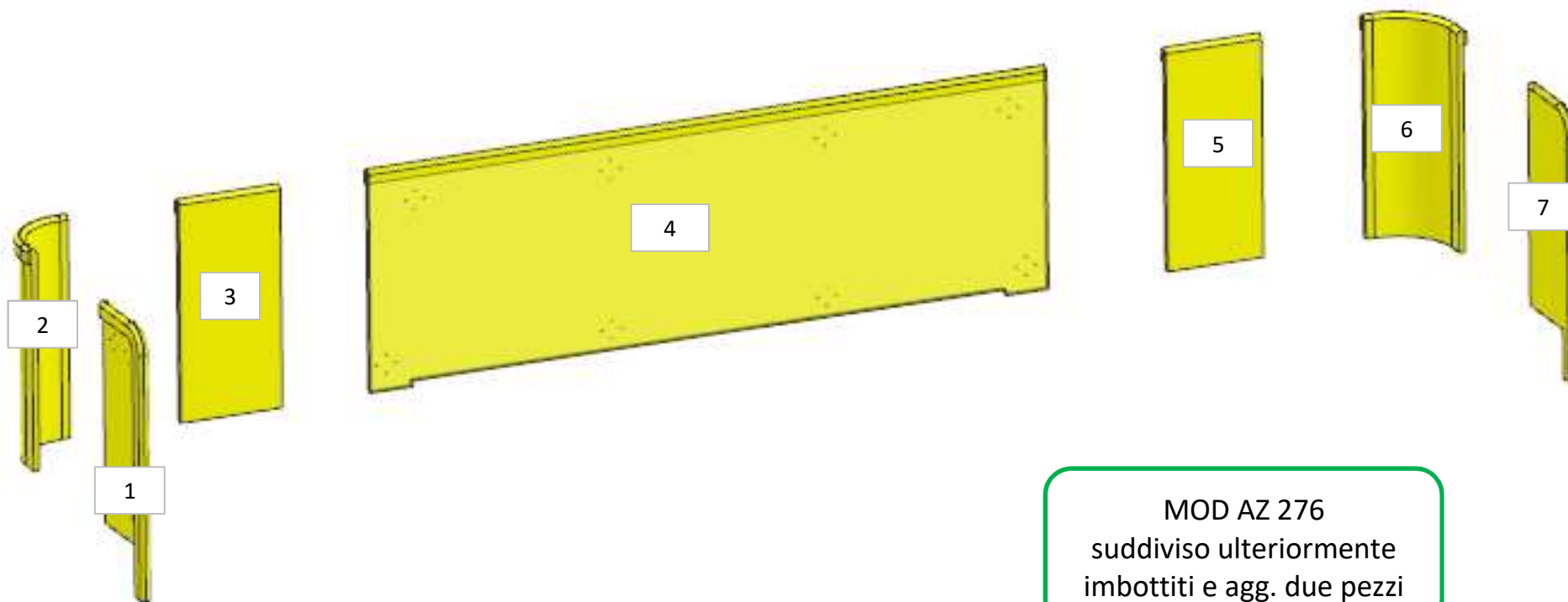

- 1 - 7 - L 239 x H 756 x sp 200
- 2 - 6 - SVILUPPO L 177 x H 619 x sp 25
- 3 - 5 L 266 x H 619 x sp 25
- 4 - L 1781 x H 619 x sp 25

AZ26M

REV. GR 9

LOCALE	CODICE	DESCRIZIONE COMPONENTE	FINITURA	Q.TA	OPERATORE
CABINA VIP SX	AZ26M-I01_VVC01	STRUTTURA LETTO	OKOUME' GREZZO	3	Dante

1 - 3 - L 1705 x H 200 x sp 19
2 - SVILUPPO L 1920 x H 200 x sp 19

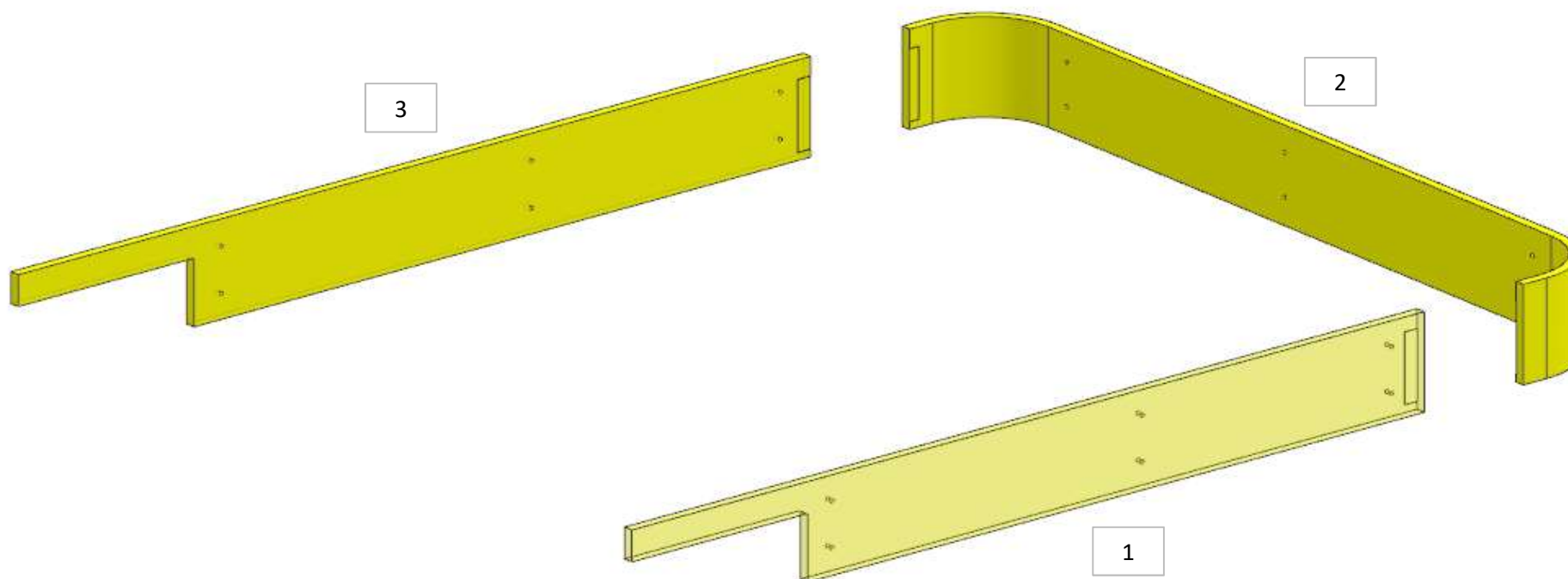

AZ26M

MOD DA GR10

REV. GR 10

LOCALE	CODICE	DESCRIZIONE COMPONENTE	FINITURA	Q.TA	OPERATORE
CABINA OSPITI DX	AZ26M-I01_RA01	STRUTTURA MURATA TESTATA LETTO	OKOUME' GREZZO	7	Damiano\Dante

- 1 - 7 - L 308 x H 759 x sp 25
- 2 - 6 - sviluppo L 328 x H 604 x sp 25
- 3 - L 344 x H 520 x sp 25
- 4- L 1729 x H 520 x sp 25
- 5- L 109 x H 520 x sp 25

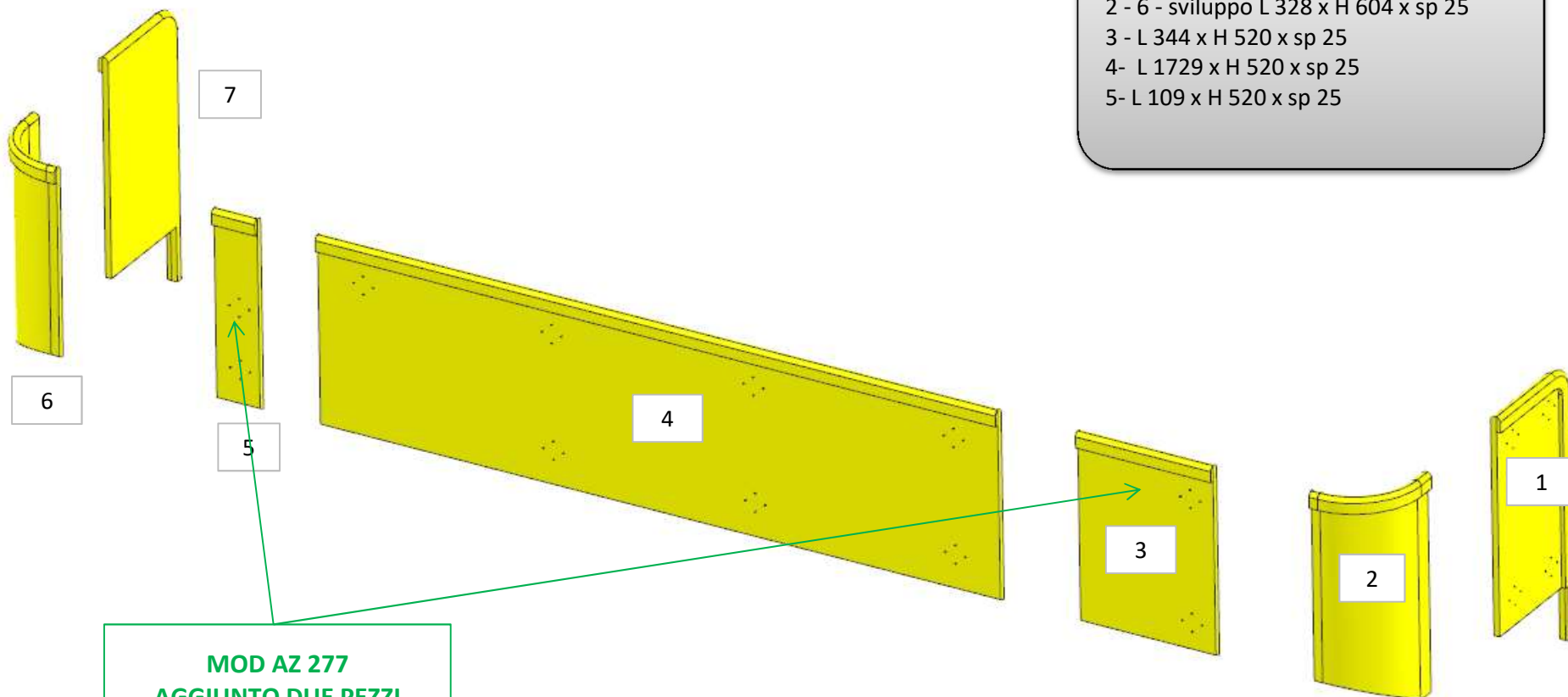

MOD AZ 277
AGGIUNTO DUE PEZZI

AZ26M

REV. GR 9

LOCALE	CODICE	DESCRIZIONE COMPONENTE	FINITURA	Q.TA	OPERATORE
CABINA OSPITI DX	AZ26M-I01_RC01	STRUTTURA LETTO	OKOUME' GREZZO	3	Dante

1 - 3 - L.1647 x H 201 x sp 19
2 - SVILUPPO L.1920 x H 201 x sp 19

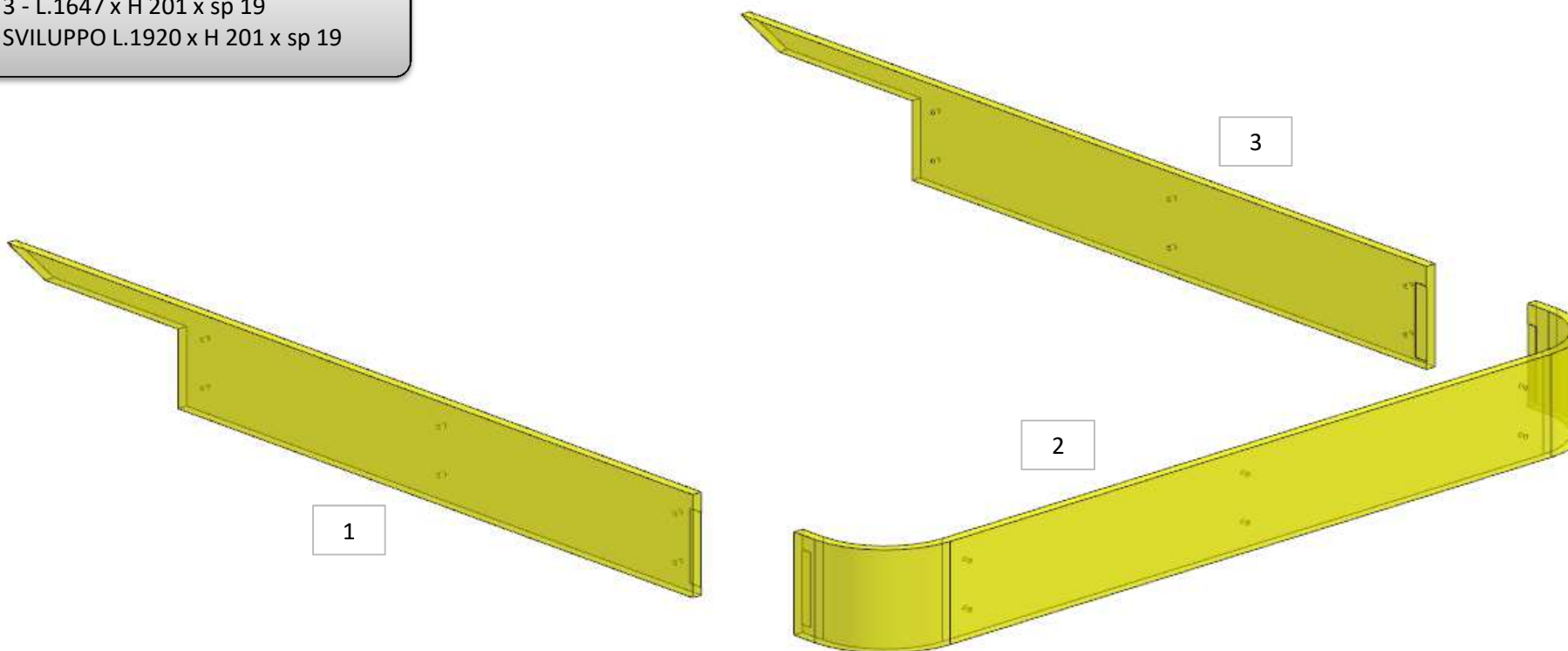

AZ26M

REV. GR 9

LOCALE	CODICE	DESCRIZIONE COMPONENTE	FINITURA	Q.TA	OPERATORE
CABINA OSPITI DX	AZ26M-I01_RRC01	STRUTTURA LETTI STD-VAR 2 -SLIDING BAD	OKOUME' GREZZO	6	Dante

- 1 - 6 - L 1647 x H 200 x sp 19
- 2 - 5 - sviluppo L 940 x H 200 x sp 19
- 3 - 4 - L 1835 x H 200 x sp 19

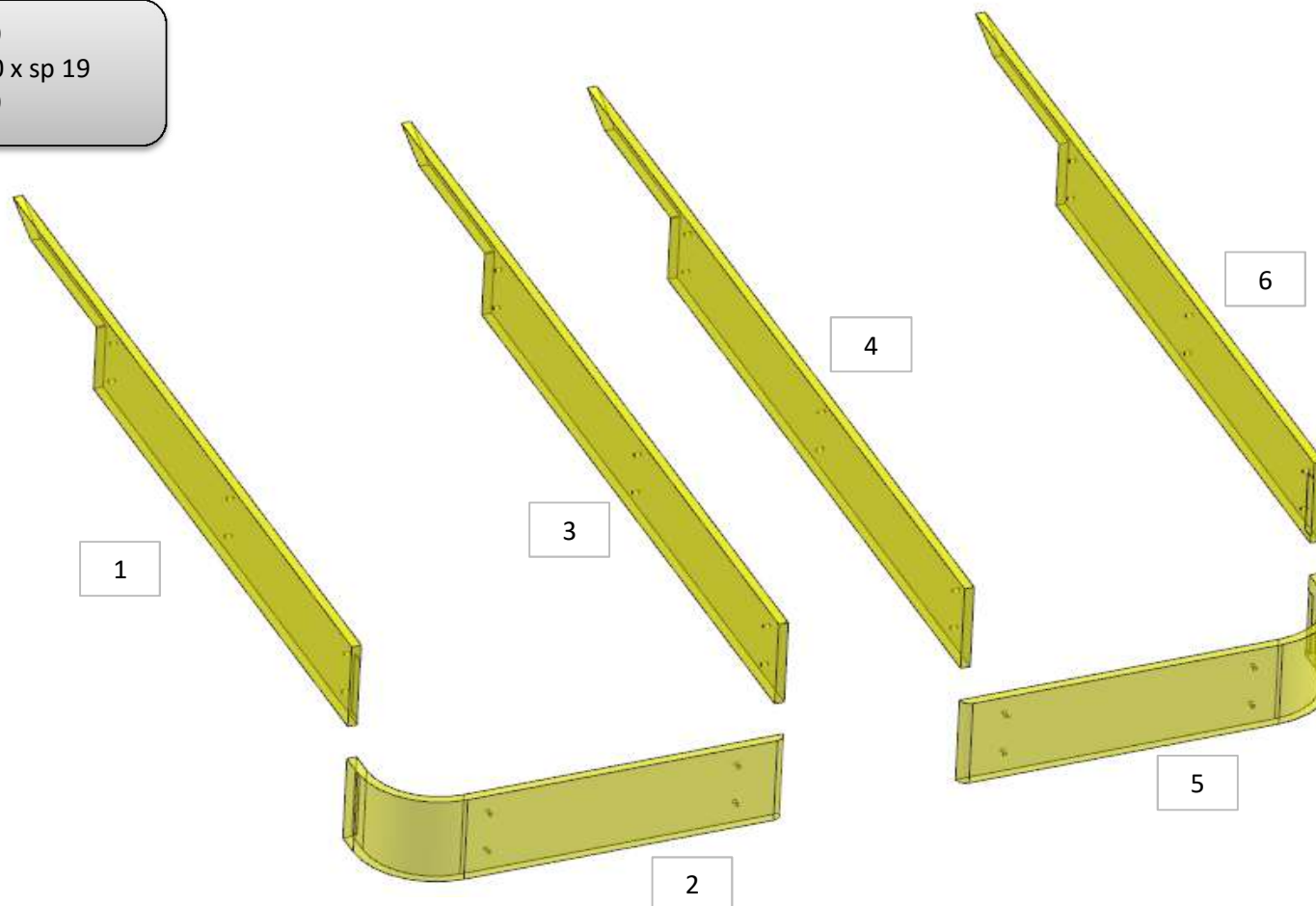

AZ26M

DA MAT. 11

REV. GR 9

LOCALE	CODICE	DESCRIZIONE COMPONENTE	FINITURA	Q.TA	OPERATORE
CABINA OSPITI SX	AZ26M-I01_LC01	STRUTTURA MURATA	OKOUME' GREZZO	2	Dante

1 - L 306 x H 560 x sp 19
2 - L 2967 x H 560 x sp 19

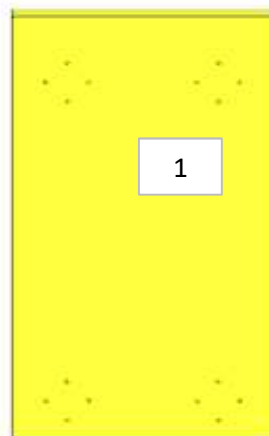

DETTAGLIO

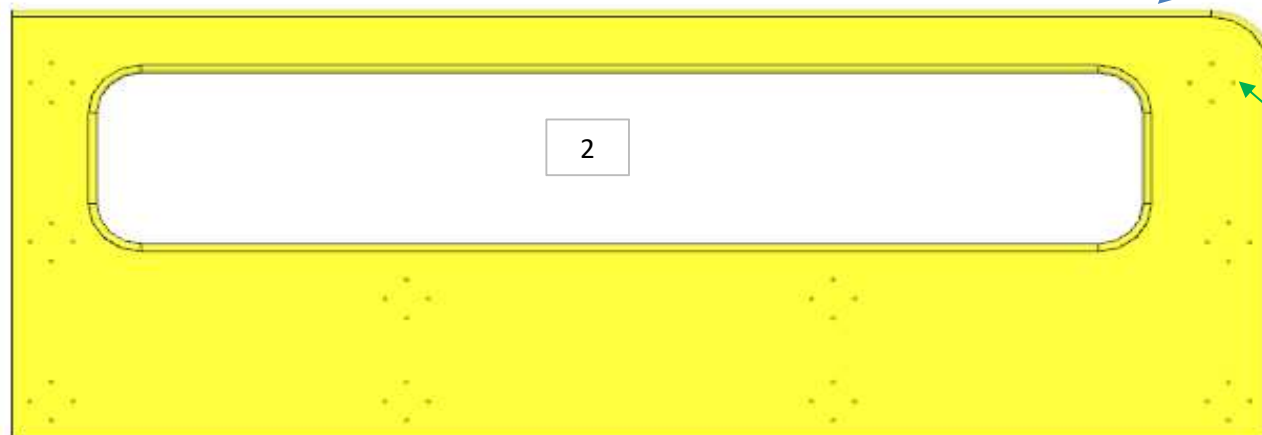

SPOSTATO QUESTI
FORI FITLOCK

consonni&c

AZ26M

REV. GR 9

LOCALE	CODICE	DESCRIZIONE COMPONENTE	FINITURA	Q.TA	OPERATORE
CABINA OSPITI SX	AZ26M-I01_LE01	STRUTTURA TESTATA LETTO	OKOUME' GREZZO	4	Dante

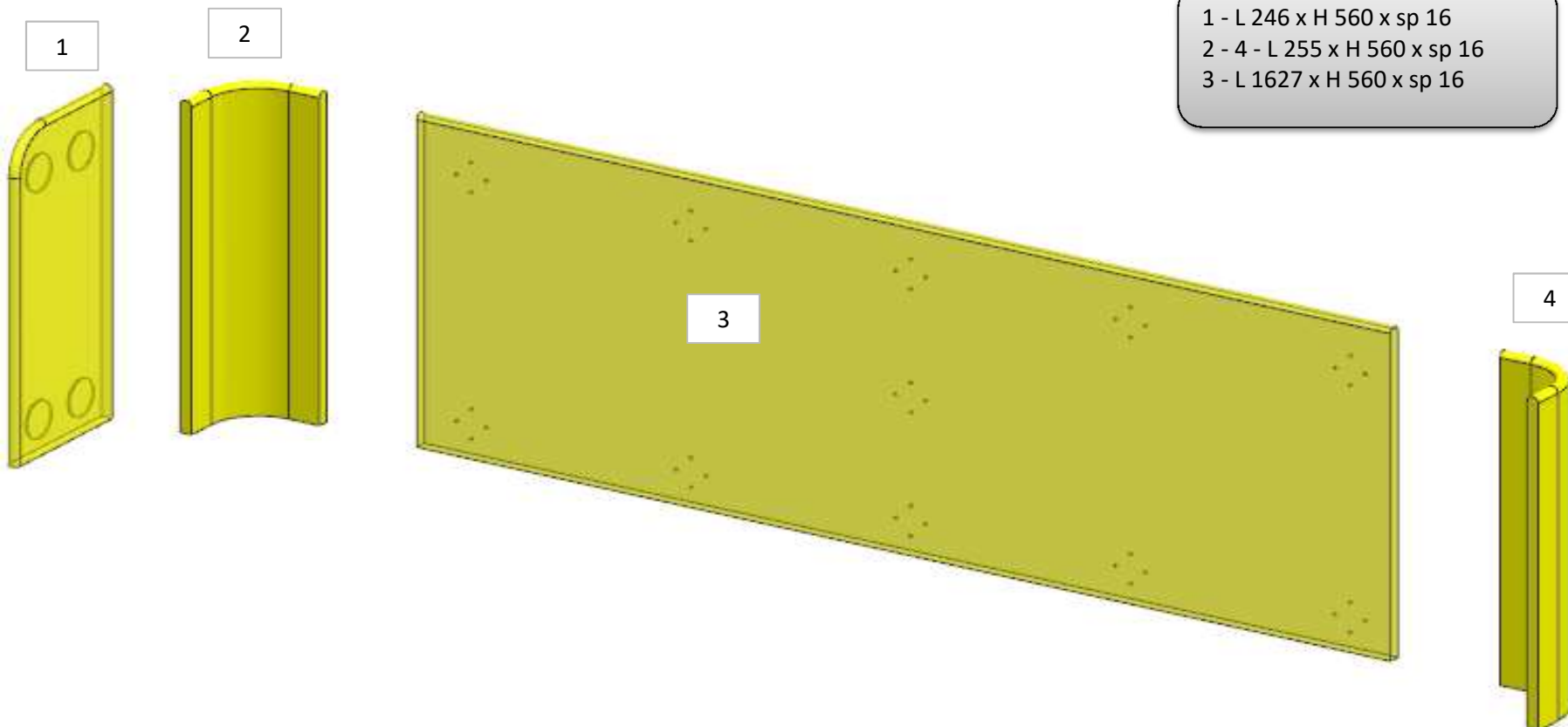

AZ26M

DA MAT. 11

REV. GR 9

LOCALE	CODICE	DESCRIZIONE COMPONENTE	FINITURA	Q.TA	OPERATORE
CABINA OSPITI SX	AZ26M-I01_LG01	LETTO MURATA	OKOUME' GREZZO	2	Dante

- 1 - L.1795 x H 201 x sp 19
- 2 - SVILUPPO L 851 x H 201 x sp 19

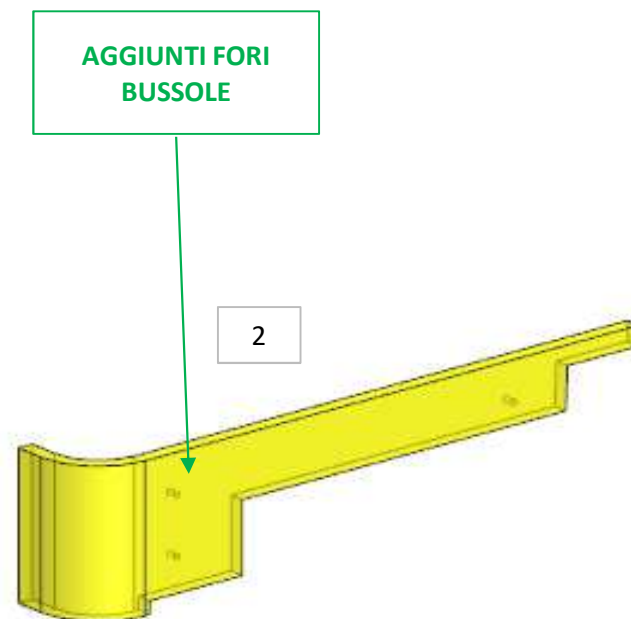
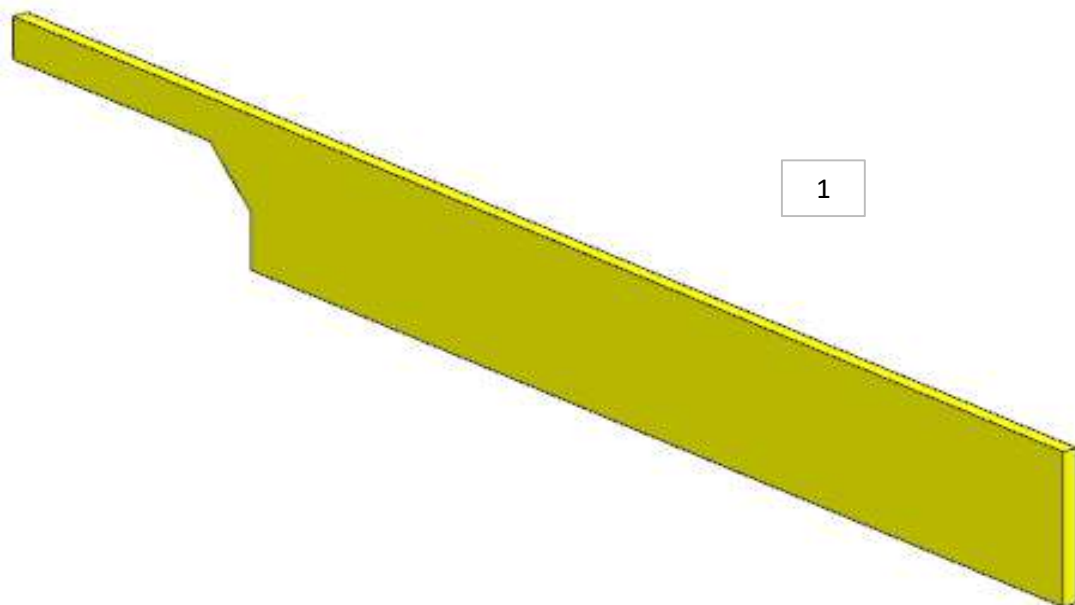

AZ26M

DA MAT. 11

REV. GR 9

LOCALE	CODICE	DESCRIZIONE COMPONENTE	FINITURA	Q.TA	OPERATORE
CABINA OSPITI SX	AZ26M-I01_LH01	LETTO CENTRO NAVE	OKOUME' GREZZO	3	Dante

- 1 - L.1415 x H 200 x sp 19
- 2 - sviluppo L.957 x H 201 x sp 19
- 3 - L.1795 x H 201 x sp 19

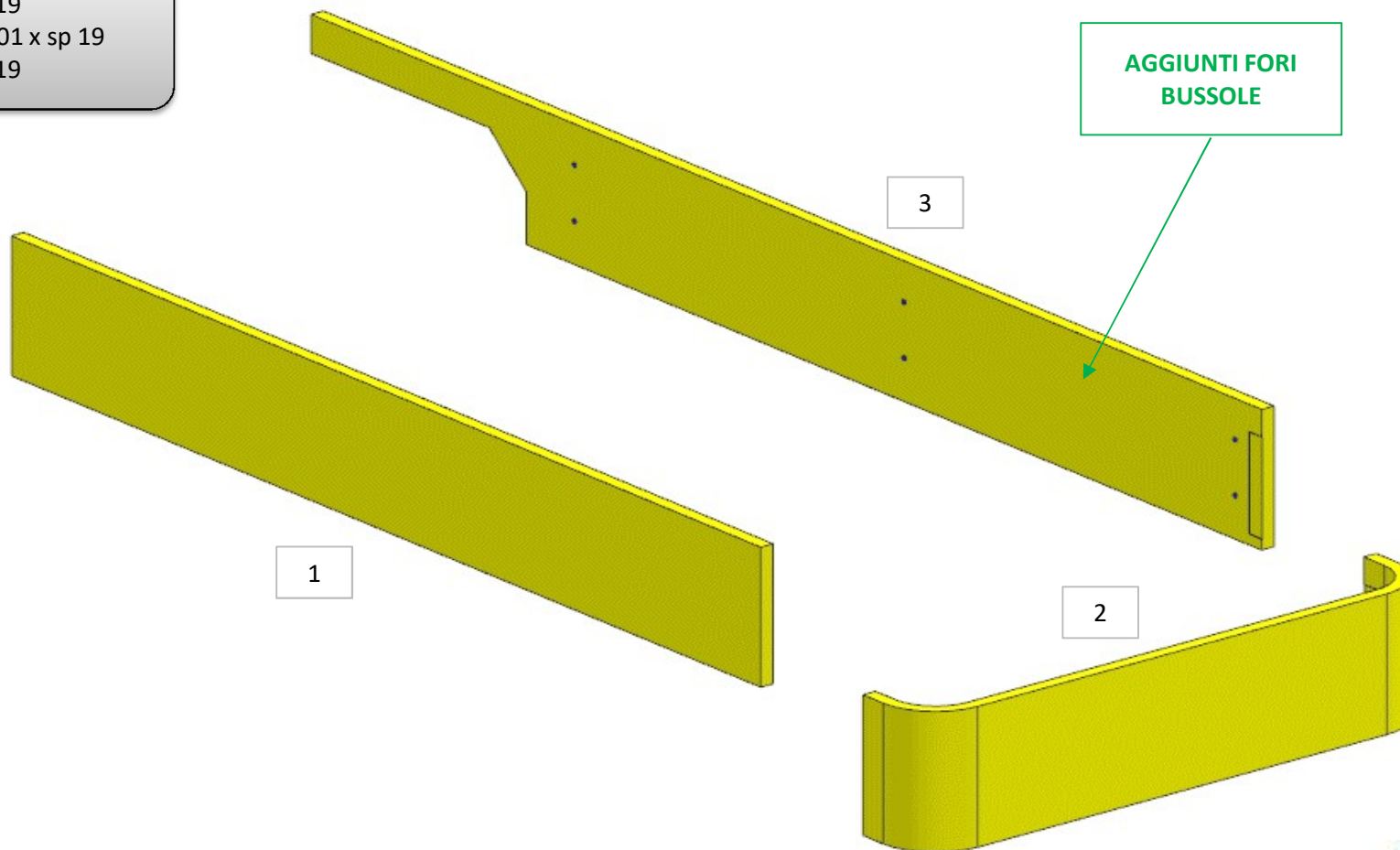

AZ26M

MOD DA GR9

REV. GR 9

LOCALE	CODICE	DESCRIZIONE COMPONENTE	FINITURA	Q.TA	OPERATORE
LOBBY	AZ26M-I01_CB01	RIVESTIMENTI IMBOTTITI POPPA	OKOUME' GREZZO	4	Damiano

- 1 - L.613 x H 2043 x sp 10
- 2 - L 165 x H 2043 x sp 10
- 3 - L.511 x H 2043 x sp 10
- 4 - L.513 x H 2043 x sp 10

MOD AZ 216
ALLUNGATO RIVESTIMENTO
VESRO PAVIMENTO E
RIMOSSI TUTTI I LAMINATI
NERI

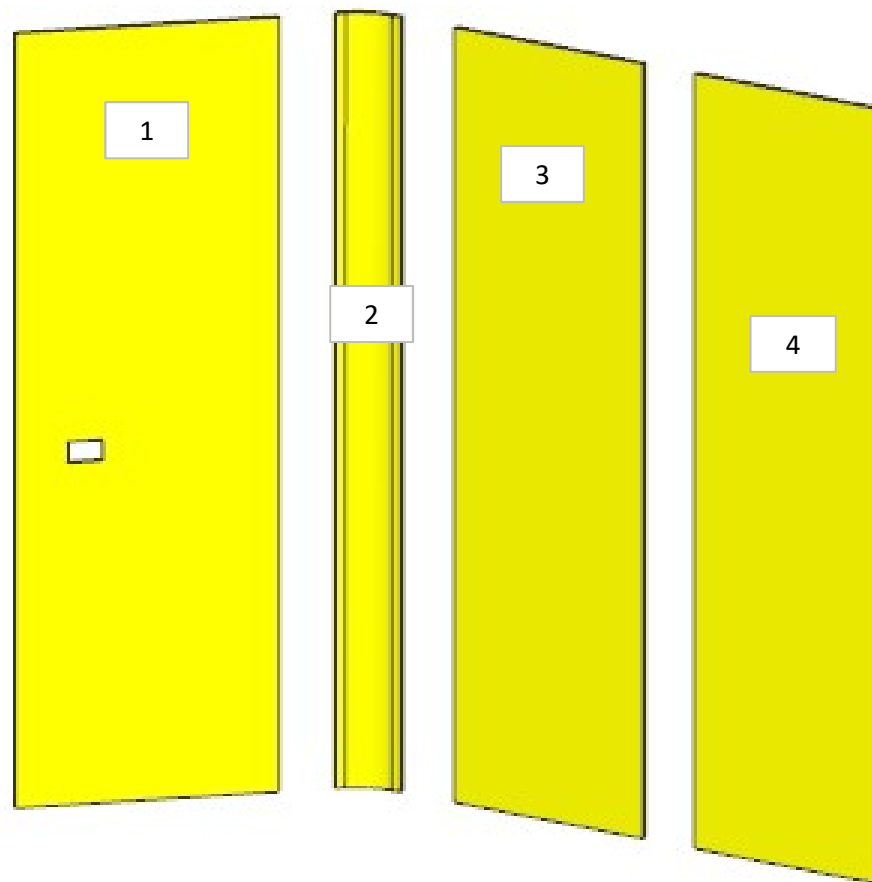

ELEMENTO DA MONTARE con:
A01_CB01
e spedire con un unico imballo

A01_CB01

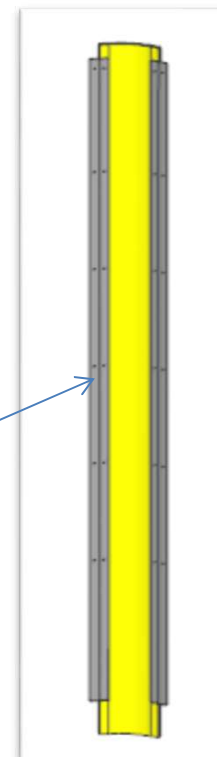

consonni&c

AZ26M

MOD GR4

REV. GR 9

LOCALE	CODICE	DESCRIZIONE COMPONENTE	FINITURA	Q.TA	OPERATORE
CABINA ARMATORE	AZ26M-I01_AH01	TESTATA LETTO	OKOUME' GREZZO	5	Dante

- 1 - L 197 x H.251 x sp 10
- 2 - L 339 x H.468 x sp 25
- 3 - L 1850 x H.468 x sp 25
- 4 - L 1286 x H.807 x sp 25
- 5 - L 152 x H.807 x sp 25

MOD. INT. 22
VASCHETTA DIVENTATA
LACCATA AZ26M-
MG_AH01

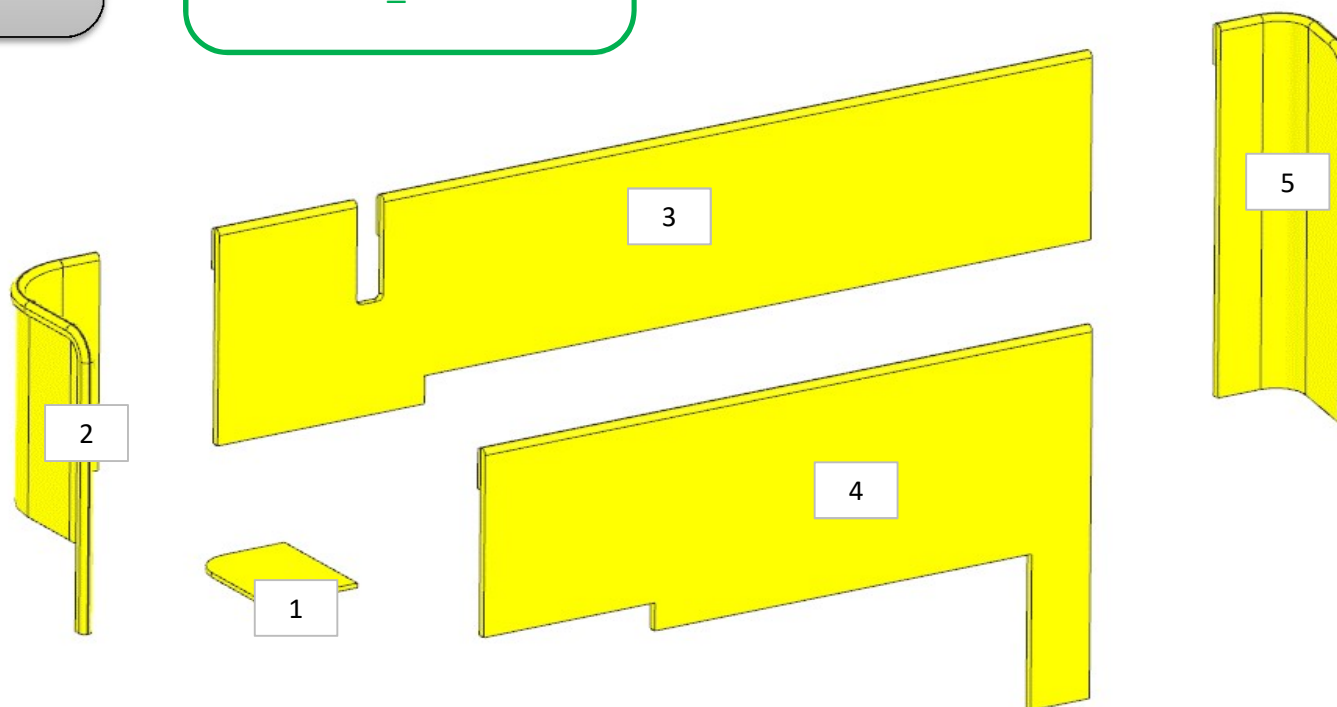

AZ26M

REV. GR 9

LOCALE	CODICE	DESCRIZIONE COMPONENTE	FINITURA	Q.TA	OPERATORE
CABINA ARMATORE	AZ26M-I01_AM01	LETTO	OKOUME' GREZZO	6	Dante

- 1 - 6 - L 1914 x H.301 x sp 19
- 2 - 5 - L 245 x H.301 x 80
- 3 - 4 - L 653 x H.299 x sp 19

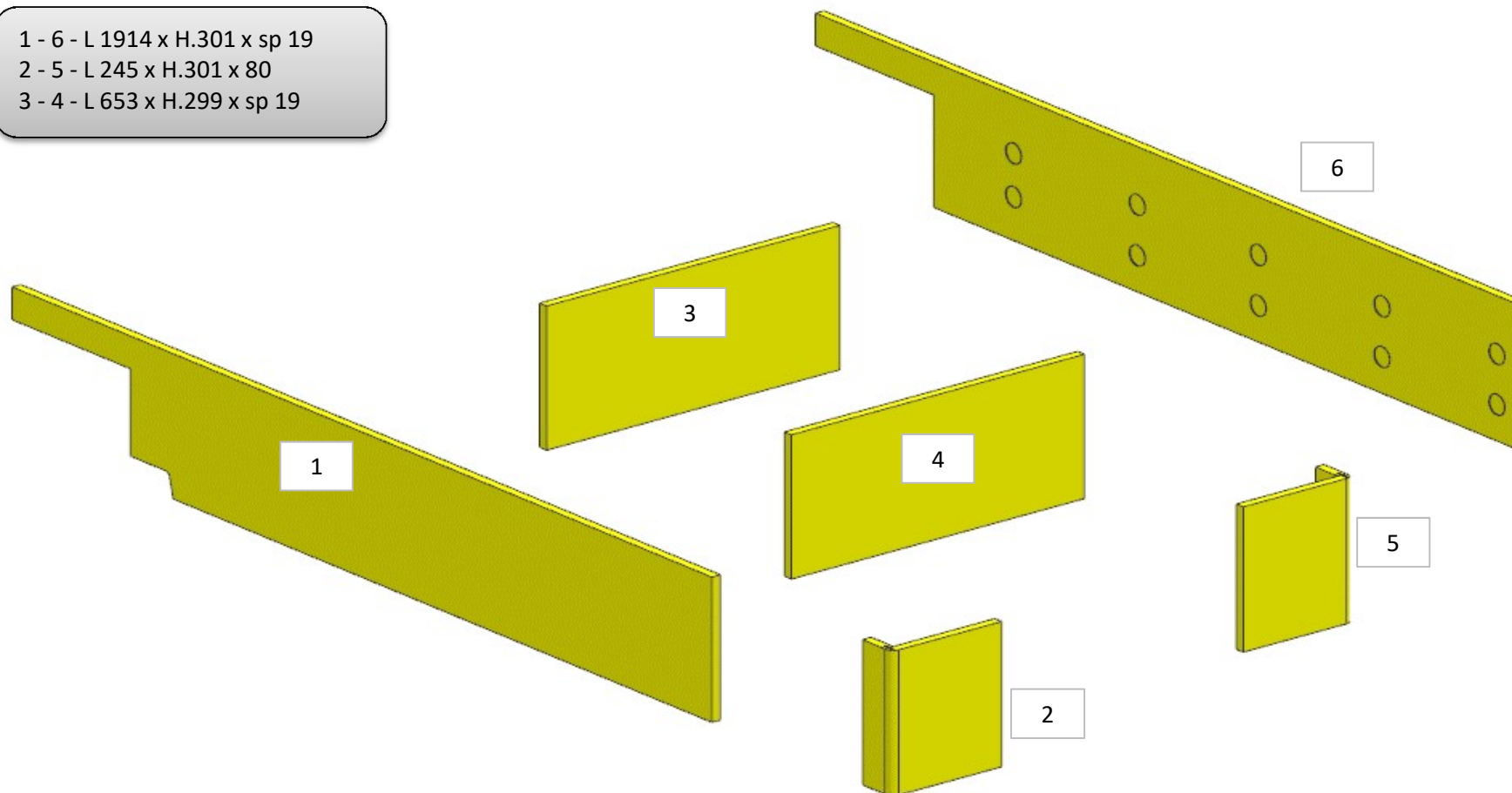

AZ26M

MOD GR4

REV. GR 9

LOCALE	CODICE	DESCRIZIONE COMPONENTE	FINITURA	Q.TA	OPERATORE
CABINA ARMATORE	AZ26M-I01_AX01	CIELINO MURATA POPPA DX	OKOUME' GREZZO	4	Dante

- 1 - L. 1238 x H 387 x sp 10
- 2 - L. 1387 x H 234 x sp 10
- 3 - L. 2115 x H 502 x sp 10
- 4 - L. 956 x H 261 x sp 10

MOD AZ 157
realizzato unico pezzo
imbottiti da stoffare

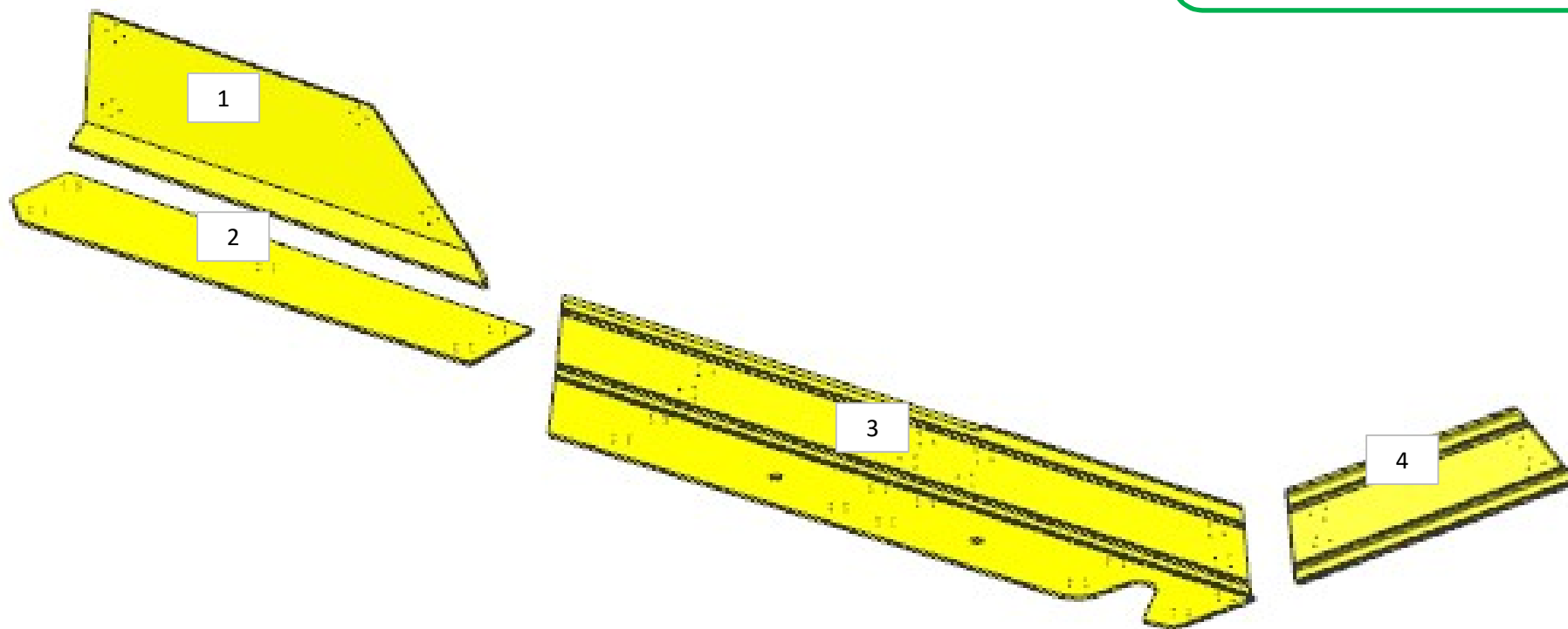

consonni&c

AZ26M

MOD GR4

REV. GR 9

LOCALE	CODICE	DESCRIZIONE COMPONENTE	FINITURA	Q.TA	OPERATORE
CABINA ARMATORE	AZ26M-I01_-AY01	CIELINO MURATA POPPA SX	OKOUME' GREZZO	1	Dante

1 - L. 2890 x H 550 x sp 10

MOD AZ 158
realizzato unico pezzo
imbottiti da stoffare

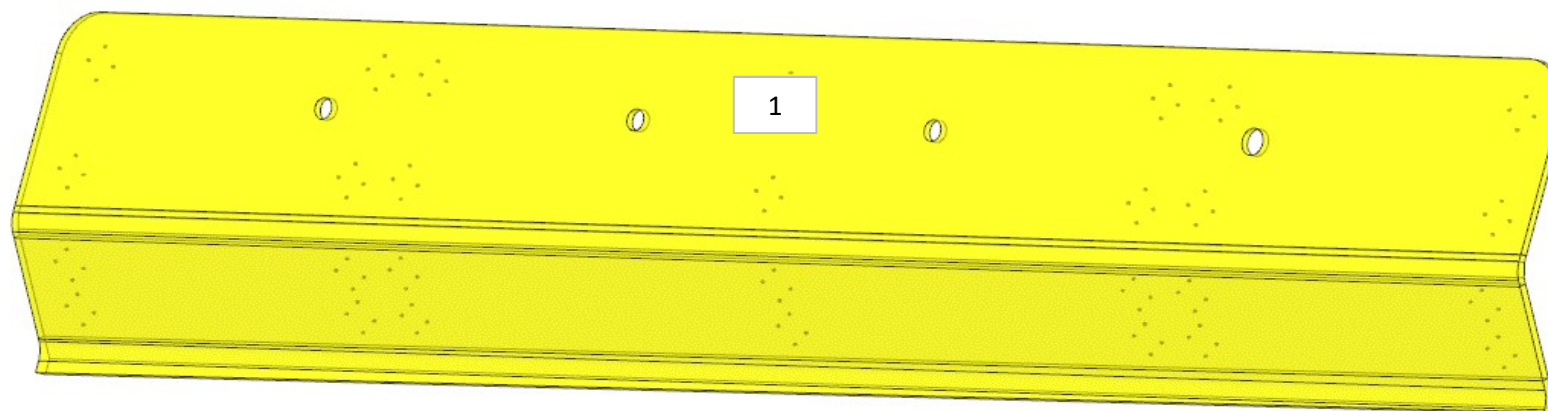

AZ26M

MOD GR7

REV. GR 9

LOCALE	CODICE	DESCRIZIONE COMPONENTE	FINITURA	Q.TA	OPERATORE
CABINA ARMATORE	AZ26M-I01_AZ01	CIELINO PARTE CENTRALE	OKOUME' GREZZO	9	Dante

- 1 - L. 784 x H 695 x sp 10
- 2 - L. 1292 x H 695 x sp 10
- 3 - L. 1166 x H 695 x sp 10
- 4 - L. 1045 x H 1500 x sp 10
- 5 - L. 1500 x H 1292 x sp 10
- 6 - L. 1123 x H 1500 x sp 10
- 7 - L. 920 x H 726 x sp 10
- 8 - L. 1292 x H 660 x sp 10
- 9 - L. 672 x H 660 x sp 10

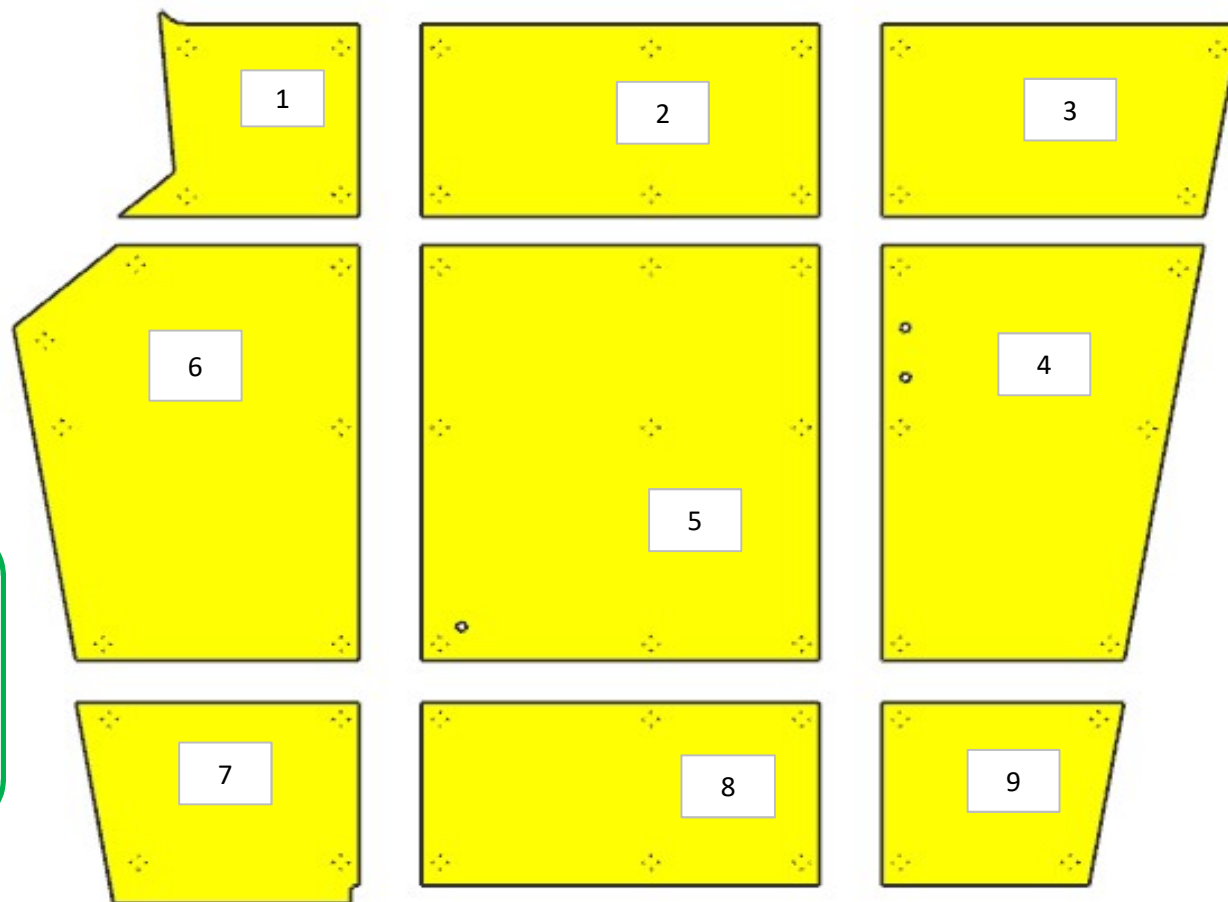

MOD AZ 152

modificato pz
02/03/05/04/08/09 taglio
allineato allo scuretto a
parete

AZ26M

MOD DA GR4

REV. GR 9

LOCALE	CODICE	DESCRIZIONE COMPONENTE	FINITURA	Q.TA	OPERATORE
BAGNO ARMATORE	AZ26M-I01_WL01	CASSETTIERA MOBILE BAGNO	OKOUME' GREZZO	1	Dante

1 - L 1167 x H..325 x 32

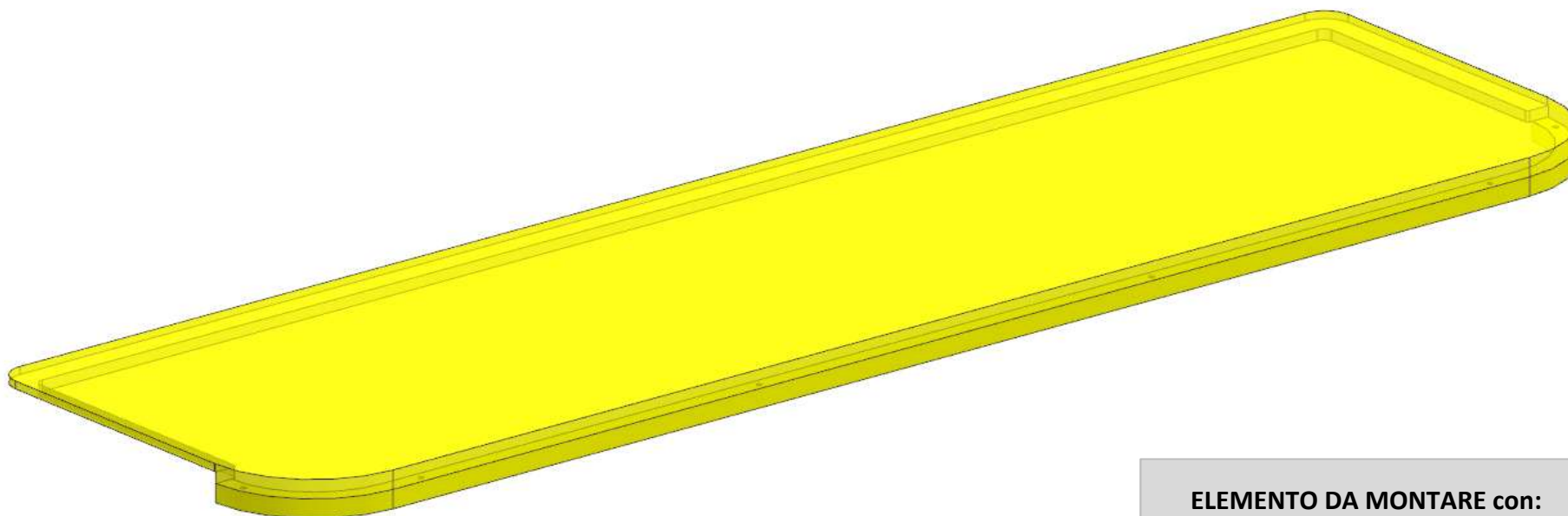

ELEMENTO DA MONTARE con:
R01_WL01
e spedire con un unico imballo

AZ26M

REV. GR 9

LOCALE	CODICE	DESCRIZIONE COMPONENTE	FINITURA	Q.TA	OPERATORE
BAGNO ARMATORE	AZ26M-I01_WQ01	CIELINO ZONA LAVELLO	OKOUME' GREZZO	4	Dante

1 - 3 - L 559 x H.389 x SP 10
2 - 4 - L 545 x H.389 x SP 10

