

AZ26M

REV. 01-2023

REV. GR 9

| LOCALE | CODICE | DESCRIZIONE COMPONENTE | FINITURA | Q.TA | OPERATORE |
|-----------------|---------------|---------------------------|----------|------|-----------|
| CABINA ARMATORE | AZ26M-MG_AA01 | ARMADIO INGRESSO DX POPPA | | | Damiano |

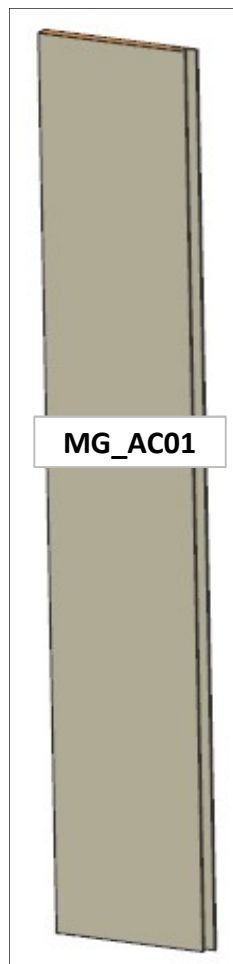

AZ26M

REV. 01-2023

REV. GR 9

| LOCALE | CODICE | DESCRIZIONE COMPONENTE | FINITURA | Q.TA | OPERATORE |
|-----------------|----------------|---------------------------|---------------|------|-----------|
| CABINA ARMATORE | AZ26M-R01_AA01 | ARMADIO INGRESSO DX POPPA | LASTRA CHIARA | 6 | Damiano |

MOD PTP
MODIFICA CODIFICA

ATTENZIONE:
SPINARE MA NON
INCOLLARE

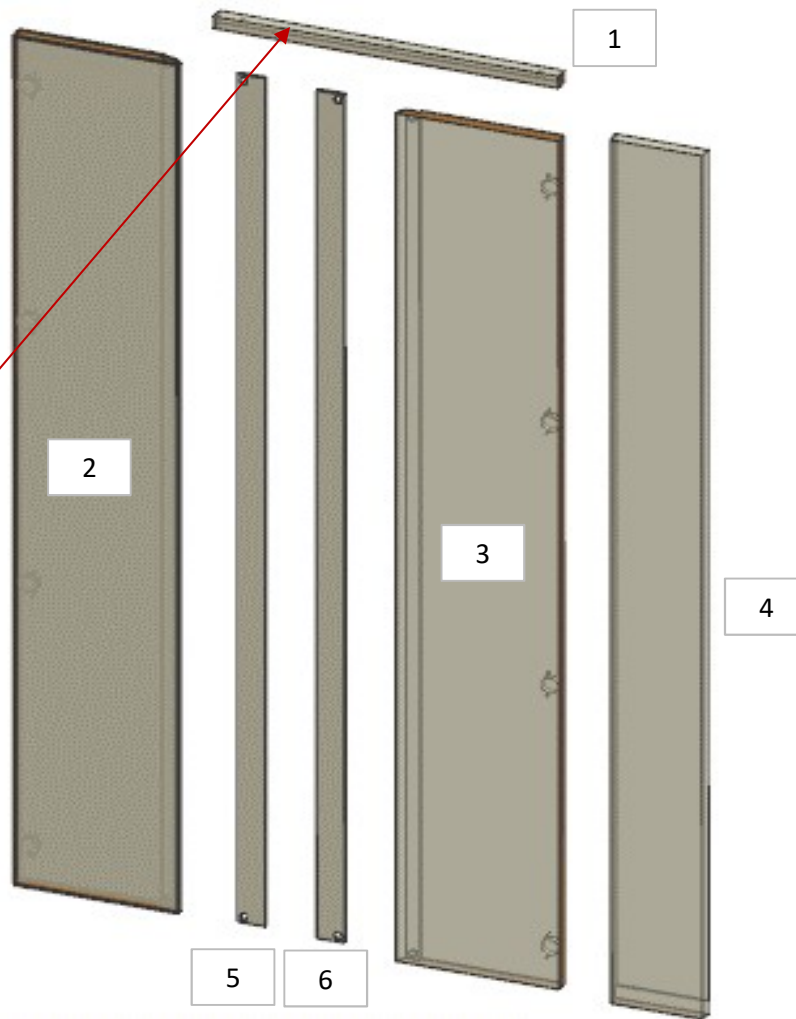

- 1 - L.659 x H.28 x sp 25
- 2 - 3 - L.314 x H.1963 x sp 25
- 4 - L.147 x H.1998 x sp 25
- 5 - 6 - L.53 x H.1963 x sp 6

ELEMENTO DA MONTARE con:
R01_AA01_02/05
R01_AA01_03/06
e spedire con un unico imballo

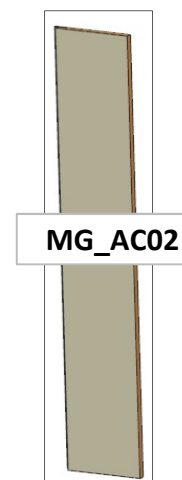
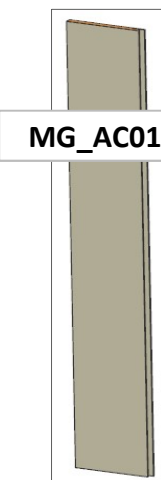

consonni&c

AZ26M

MOD GR4

REV. GR 9

| LOCALE | CODICE | DESCRIZIONE COMPONENTE | FINITURA | Q.TA | OPERATORE |
|-----------------|---------------|---------------------------|----------|------|-----------|
| CABINA ARMATORE | AZ26M-MG_AB01 | ARMADIO INGRESSO SX POPPA | | | Damiano |

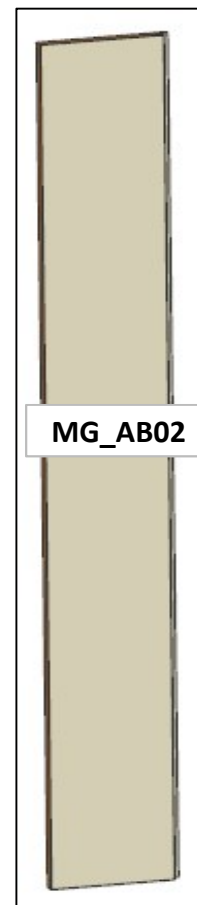
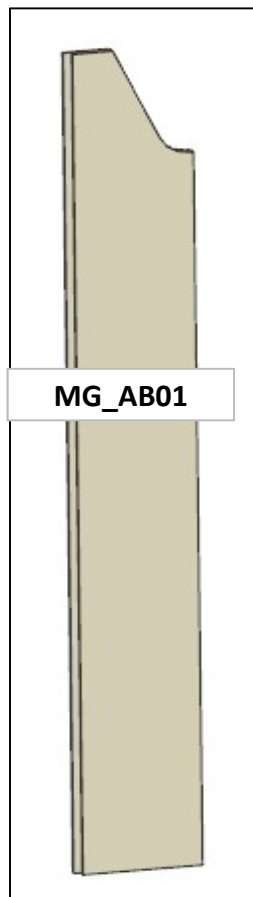

AZ26M

MOD DA GR9

REV. GR 9

| LOCALE | CODICE | DESCRIZIONE COMPONENTE | FINITURA | Q.TA | OPERATORE |
|-----------------|----------------|---------------------------|---------------|------|-----------|
| CABINA ARMATORE | AZ26M-R01_AB01 | ARMADIO INGRESSO SX POPPA | LASTRA CHIARA | 11 | Damiano |

1 - 2 - L. 262 x H 1963 x sp 25
 3 - L. 73 x H 1968 x sp 25
 4 - L. 134 x H 1966 x sp 11
 5 - L. 516 x H 95 x sp 20

6 - L. 455 x H 26 x sp 41
 7 - 8 - L 53 x H 1963 x sp 6
 9 - L 352 x H 50 x sp 16
 10 - L 273 x 208 x 96

**MOD AZ 221
 REALIZZATO
 CONTROFFACCIATA
 IN LASTRA E
 MODIFICATO**

**ELEMENTO DA MONTARE con:
 MG_AB01
 MG_AB02
 e spedire con un unico imballo**

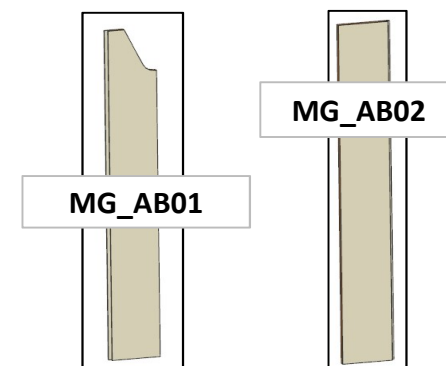
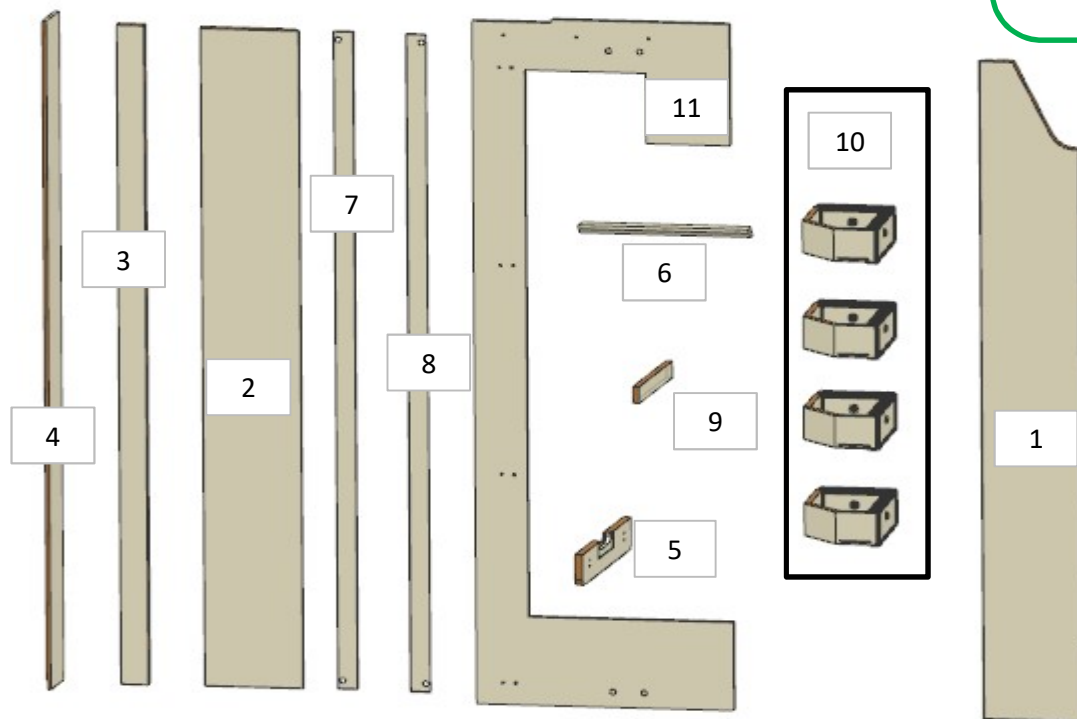

**ELEMENTO DA MONTARE con:
 L01_AB01
 e spedire con un unico imballo**

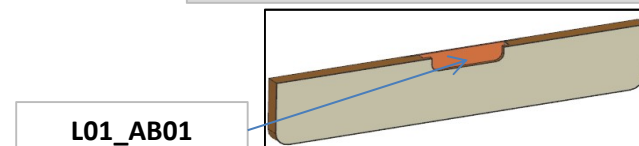

AZ26M

MOD PTP

REV. GR 9

| LOCALE | CODICE | DESCRIZIONE COMPONENTE | FINITURA | Q.TA | OPERATORE |
|-----------------|---------------|---------------------------|----------|------|-----------|
| CABINA ARMATORE | AZ26M-MF_AB01 | ARMADIO INGRESSO SX POPPA | | | Damiano |

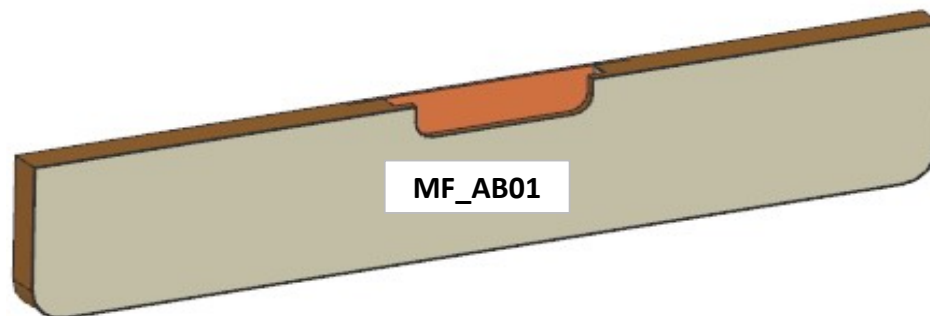

AZ26M

REV. 01-2023

REV. GR 9

| LOCALE | CODICE | DESCRIZIONE COMPONENTE | FINITURA | Q.TA | OPERATORE |
|-----------------|----------------|---------------------------|----------------|------|-----------|
| CABINA ARMATORE | AZ26M-L01_AB01 | ARMADIO INGRESSO SX POPPA | LACCATO BRONZO | 1 | Damiano |

1 - L.160 x H50 x sp 3

ELIMINATO MF

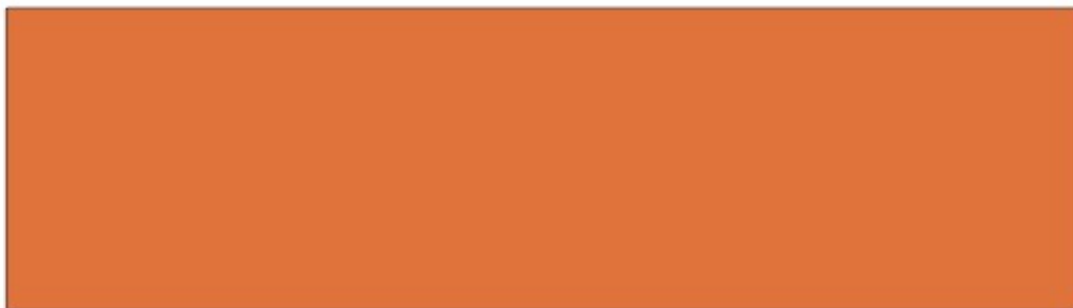

ELEMENTO DA MONTARE con:
R01_AA01
e spedire con un unico imballo

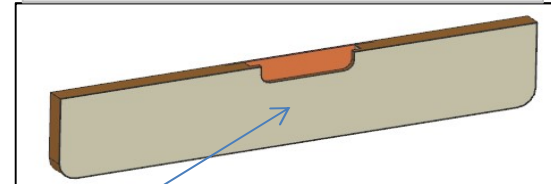

R01_AA01

AZ26M

MOD PTP

REV. GR 9

| LOCALE | CODICE | DESCRIZIONE COMPONENTE | FINITURA | Q.TA | OPERATORE |
|-----------------|------------|------------------------|----------------|------|-----------|
| CABINA ARMATORE | AZ26M-AG01 | MOBILE SOSPESO ZONA TV | LAMINATO NADIR | 1 | Damiano |

MOD PTP

MODIFICATO
TUTTA LA
STRUTTURA E
DIVISO IN 2

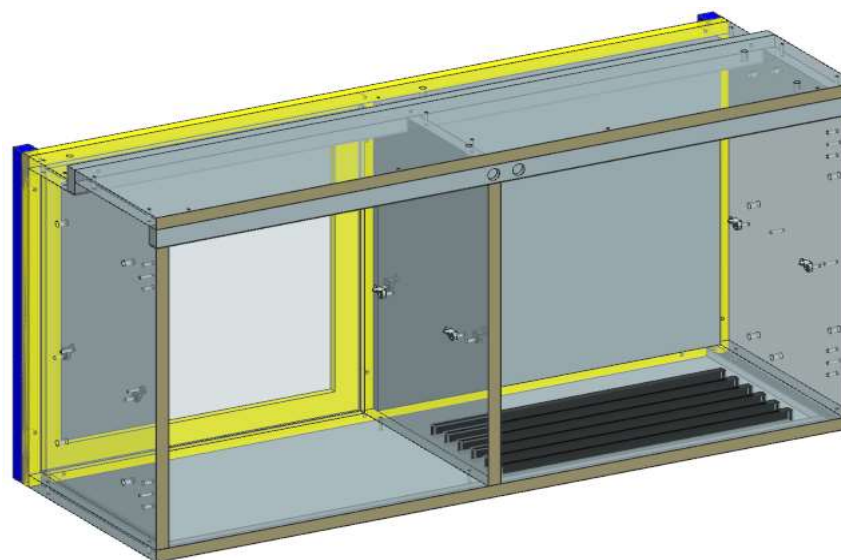

FERRAMENTA:

- N° 4 - CALAMITA AD INCASSO diam 15 SL
- N° 4 - CERNIERA PIANA BLUMOTION 95°
- N° 4 - BASETTA H3 BLUM
- N° 16 - ANKOR BORGHI
- N° 16 - VITI 4MA x 8 per ANKOR BORGHI
- N° 4 - REGGIRIPIANI 1 PERNO 1 FORO
- N° 24 - SPINA diam 8
- N° 2 - KEKU RIVOLTO
- N° 3 - MANIGLIE CUSTOM

AZ26M

MOD PTP

REV. GR 9

| LOCALE | CODICE | DESCRIZIONE COMPONENTE | FINITURA | Q.TA | OPERATORE |
|-----------------|----------------|------------------------|---------------|------|-----------|
| CABINA ARMATORE | AZ26M-R01_AG01 | MOBILE SOSPESO ZONA TV | LASTRA CHIARA | 6 | Damiano |

- 1 - L. 408 x H 66 x sp 16
- 2 - L. 438 x H 66 x sp 16
- 3 - L. 408 x H 36 x sp 16
- 4 - 6 - L. 408 x H 249 x sp 16
- 5 - L. 438 x H 249 x sp 16

MOD PTP
AGGIUNTO RIPIANI IN
LASTRA

ELEMENTO DA MONTARE con:
AG01
L01_AG01
L02_AG01
L03_AG01
L04_AG01
L05_AG01
e spedire con un unico imballo

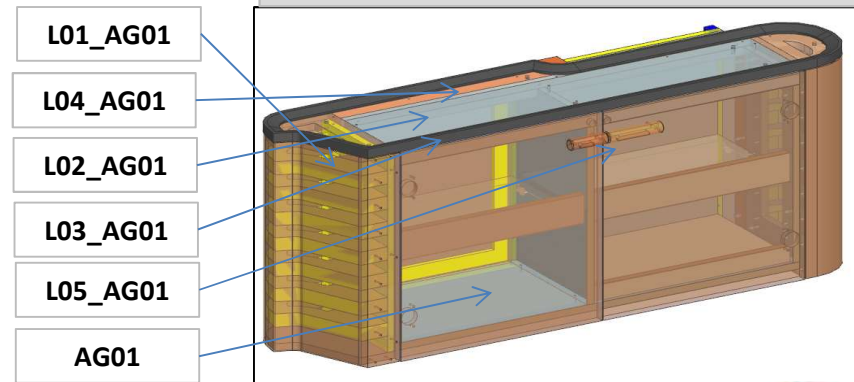
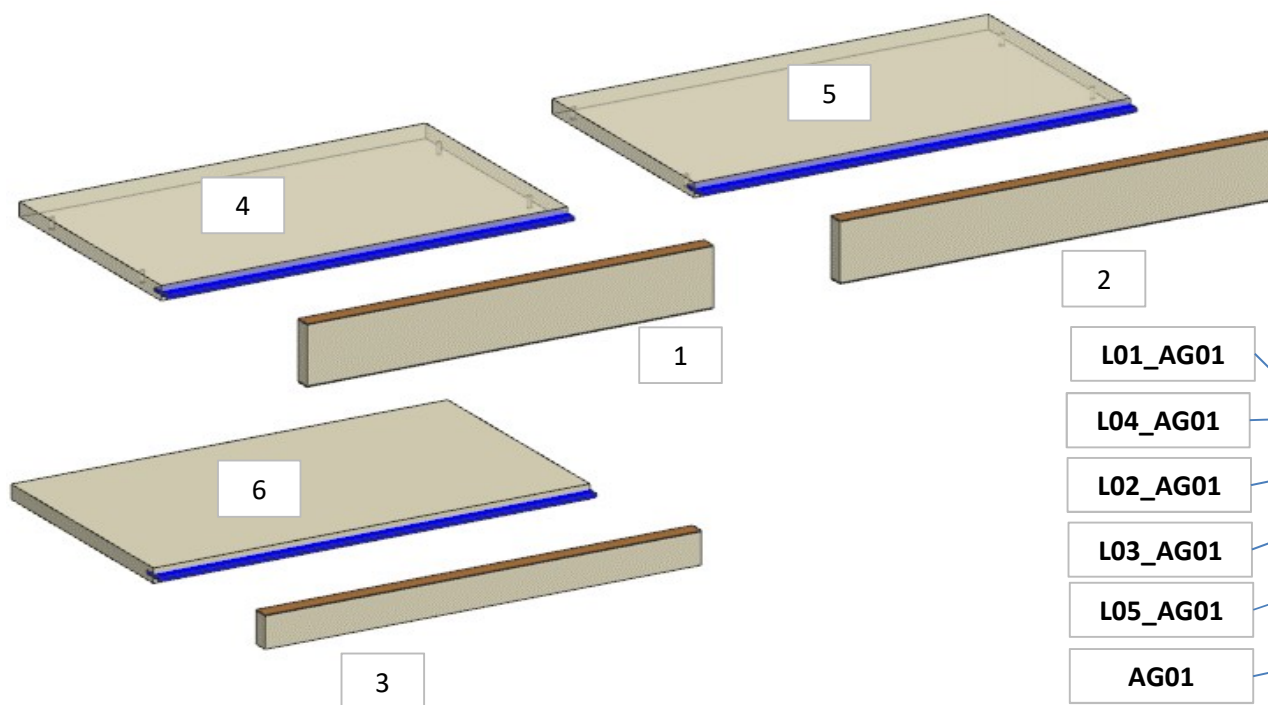

AZ26M

MOD PTP

REV. GR 9

| LOCALE | CODICE | DESCRIZIONE COMPONENTE | FINITURA | Q.TA | OPERATORE |
|-----------------|----------------|------------------------|------------------------|------|-----------|
| CABINA ARMATORE | AZ26M-L01_AG01 | MOBILE SOSPESO ZONA TV | LACCATO NCS S3020-Y30R | 4 | Damiano |

1 - L. 219 x H 475 x sp 125
2 - 3 - L. 445 x H 473 x sp 20
4 - L. 276 x H 475 x sp 177

MOD PTP
MODIFICATO ANTE

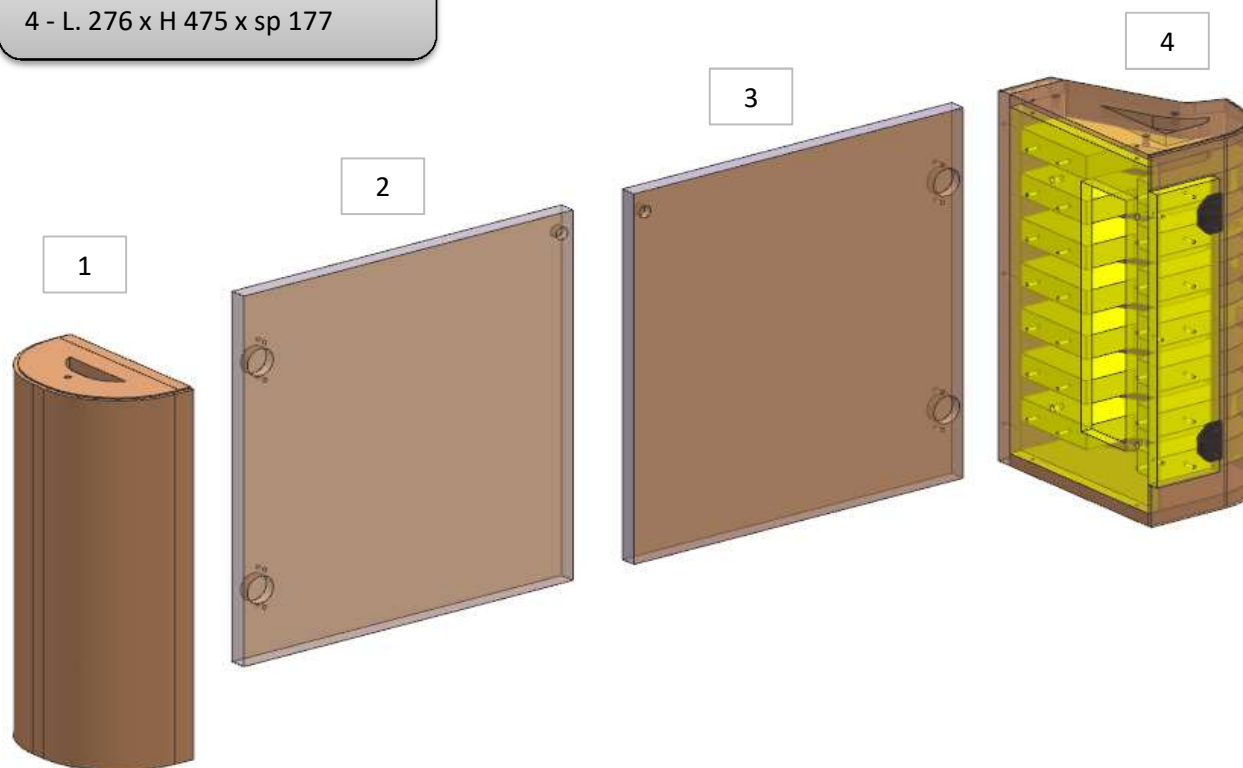

AZ26M

MOD PTP

REV. GR 9

| LOCALE | CODICE | DESCRIZIONE COMPONENTE | FINITURA | Q.TA | OPERATORE |
|-----------------|----------------|------------------------|----------------|------|-----------|
| CABINA ARMATORE | AZ26M-L02_AG01 | MOBILE SOSPESO ZONA TV | LACCATO BRONZO | 5 | Damiano |

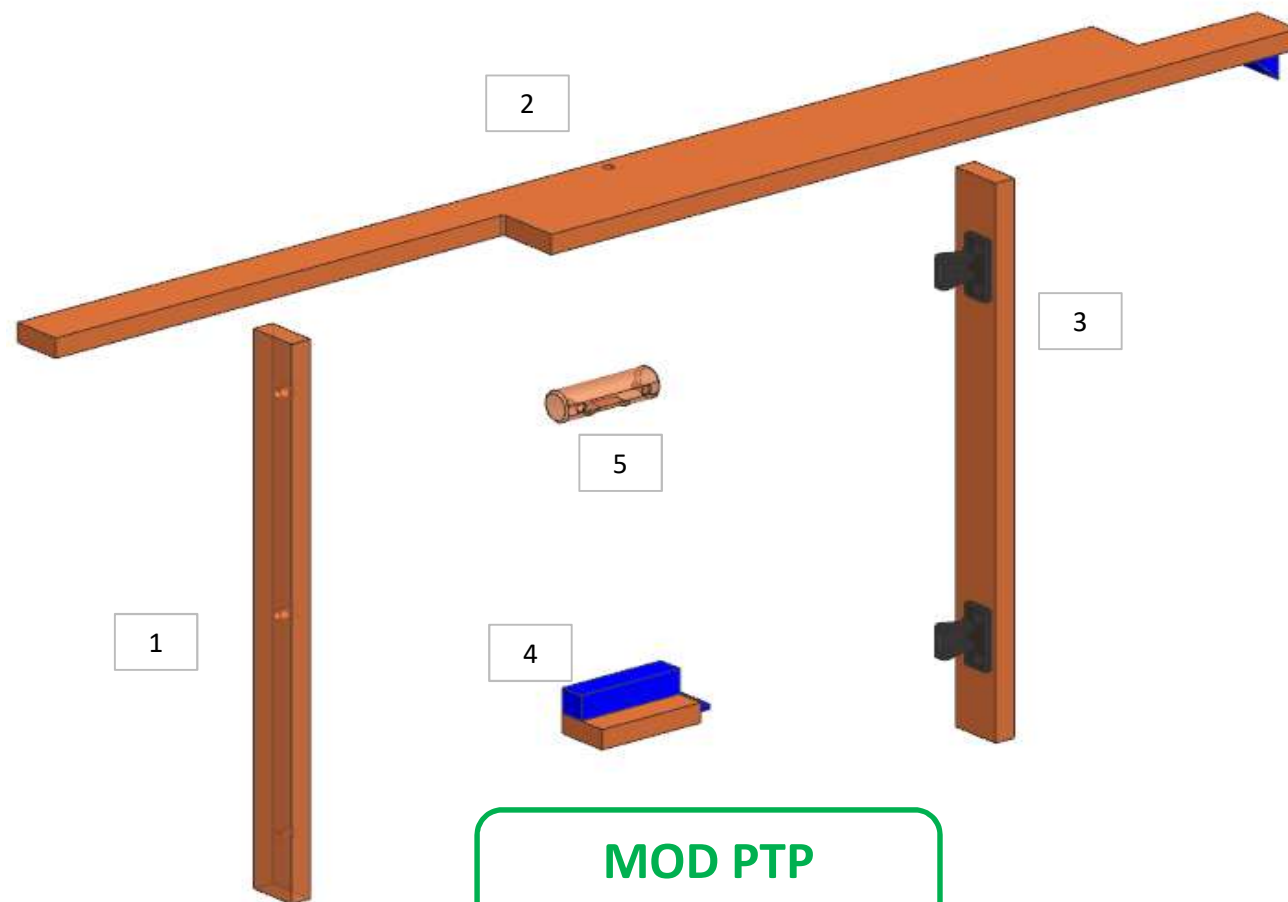

- 1 - L. 39 x H 441 x sp 16
- 2 - L. 1013 x H 89 x sp 16
- 3 - L. 41 x H 441 x sp 16
- 4 - L. 41 x H 83 x sp 16

MOD PTP
AGGIUNTO MANIGLIA

AZ26M

MOD PTP

REV. GR 9

| LOCALE | CODICE | DESCRIZIONE COMPONENTE | FINITURA | Q.TA | OPERATORE |
|-----------------|----------------|------------------------|-------------------------|------|-----------|
| CABINA ARMATORE | AZ26M-L03_AG01 | MOBILE SOSPESO ZONA TV | LACCATO BIANCO RAL 9010 | 1 | Damiano |

1 - L. 1168 x H 236 x sp 8



AZ26M

MOD PTP

REV. GR 9

| LOCALE | CODICE | DESCRIZIONE COMPONENTE | FINITURA | Q.TA | OPERATORE |
|-----------------|----------------|------------------------|------------------------------------|------|-----------|
| CABINA ARMATORE | AZ26M-L04_AG01 | MOBILE SOSPESO ZONA TV | LACCATO LUCIDO MOGANO 100 Gloss | 1 | Damiano |



AZ26M

MOD PTP

REV. GR 9

| LOCALE | CODICE | DESCRIZIONE COMPONENTE | FINITURA | Q.TA | OPERATORE |
|-----------------|----------------|------------------------|---|------|-----------|
| CABINA ARMATORE | AZ26M-L05_AG01 | MOBILE SOSPESO ZONA TV | LACCATO ARANCIONE - NCS S2050-Y50R 100 gloss | 1 | Damiano |

MOD PTP

AGGIUNTO MANIGLIA LACCATA
ARANCIONE

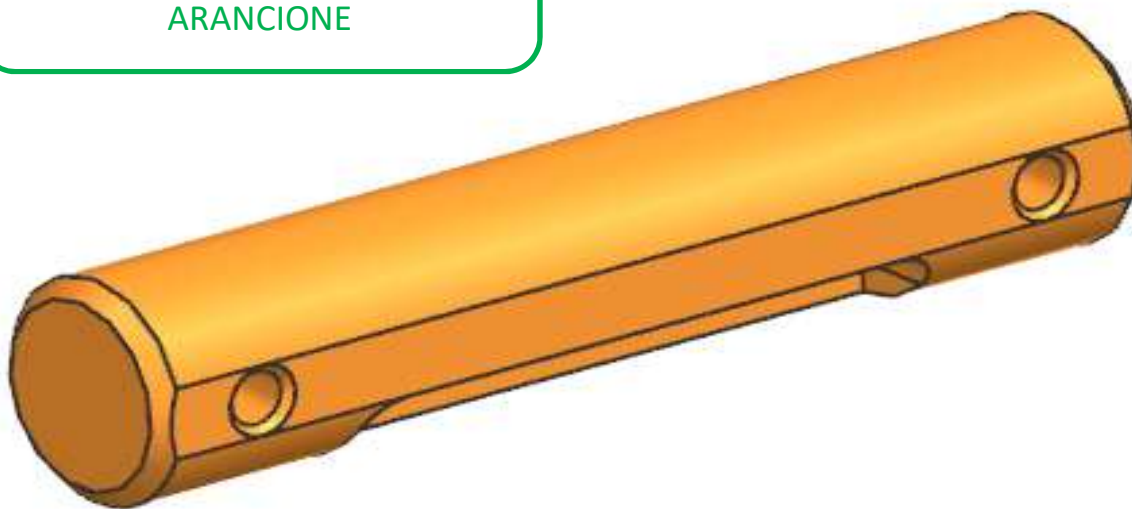

AZ26M

MOD PTP

REV. GR 9

| LOCALE | CODICE | DESCRIZIONE COMPONENTE | FINITURA | Q.TA | OPERATORE |
|-----------------|---------------|------------------------|----------|------|-----------|
| CABINA ARMATORE | AZ26M-MA_AI01 | COMODINO SX | | | |

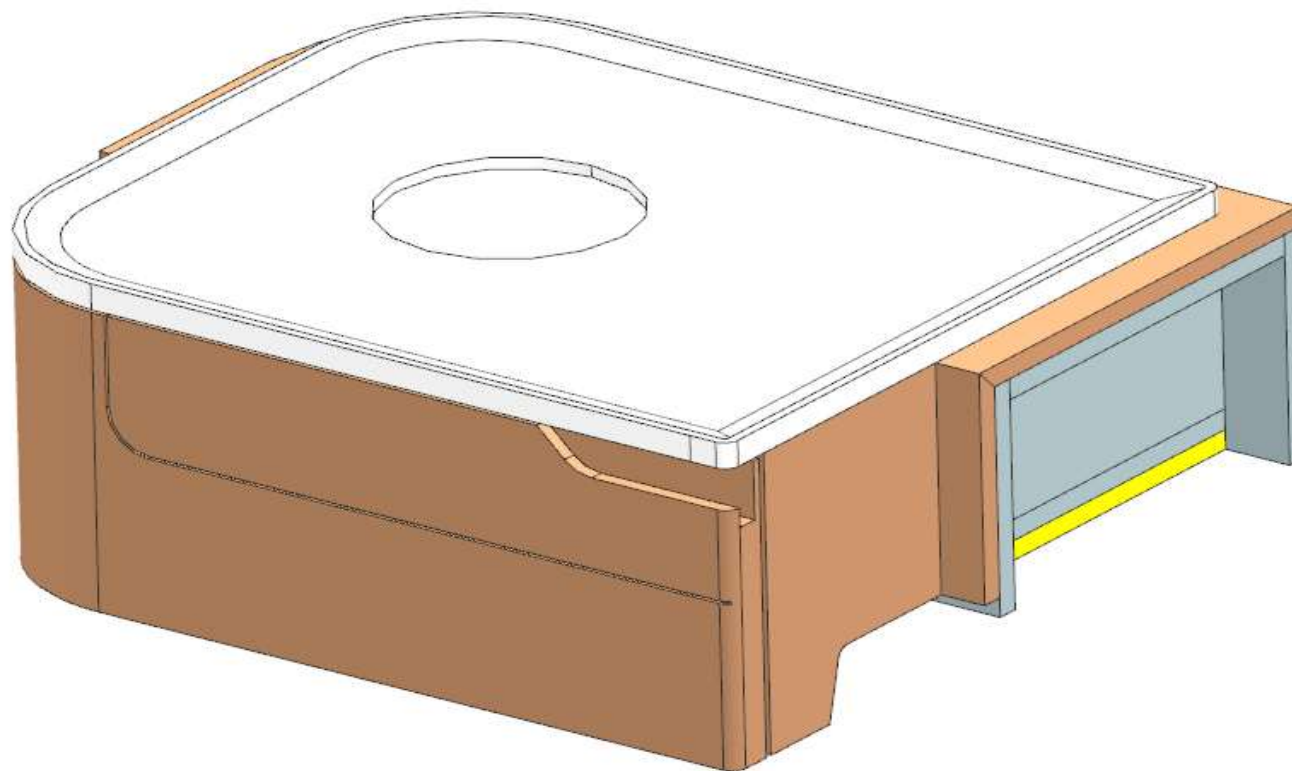

AZ26M

MOD PTP

REV. GR 9

| LOCALE | CODICE | DESCRIZIONE COMPONENTE | FINITURA | Q.TA | OPERATORE |
|-----------------|------------|------------------------|----------------|------|-----------|
| CABINA ARMATORE | AZ26M-AI01 | COMODINO SX | LAMINATO NADIR | 4 | Damiano |

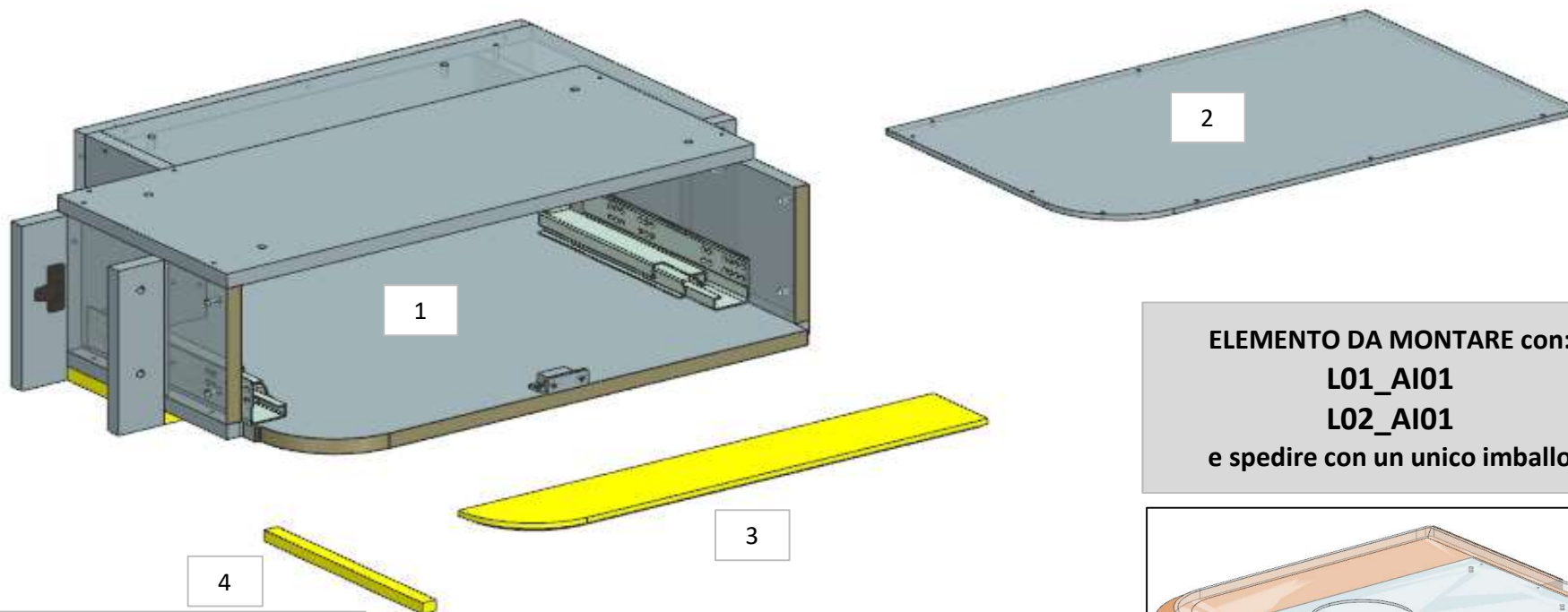

ELEMENTO DA MONTARE con:
L01_AI01
L02_AI01
e spedire con un unico imballo

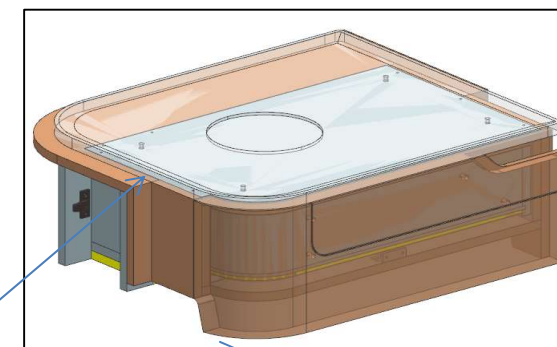

FERRAMENTA:

- N° 1 - GUIDA 250
- N° 2 - KEKU FRONTALE
- N° 1 - CALAMITA PER CASSETTI
- N° 22 - SPINA diam 8
- N° 2 - VITI 6MA

**MODIFICATO STRUTTURA
INTERNA, CASSETTO
INTERNO DIVENTATO
LACCATO**

L01_AI01
L02_AI01

AZ26M

MOD PTP

REV. GR 9

| LOCALE | CODICE | DESCRIZIONE COMPONENTE | FINITURA | Q.TA | OPERATORE |
|-----------------|----------------|------------------------|-------------------------|------|-----------|
| CABINA ARMATORE | AZ26M-L01_AI01 | COMODINO SX | LACCATO BIANCO RAL 9016 | 5 | Damiano |

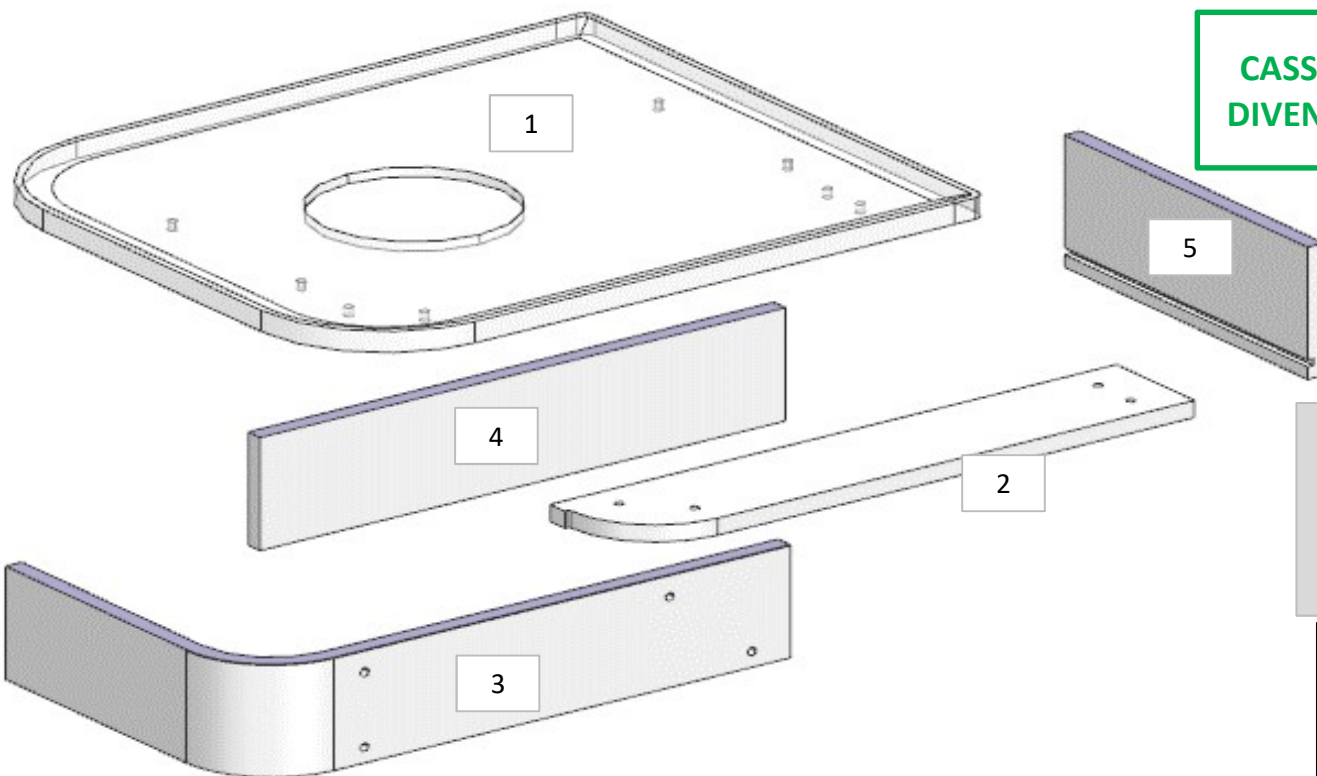

**CASSETTO
DIVENTATO**

- 1 - L. 616 x H 530 x sp 20
- 2 - L. 544 x H 103 x sp 16
- 3 - L. 526 x H 320 x sp 16
- 4 - L. 510 x H 105 x sp 16
- 5 - L. 323 x H 123 x sp 16

ELEMENTO DA MONTARE con:
AI01_02/03/04
L01_AI01_02/03/04
e spedire con un unico imballo

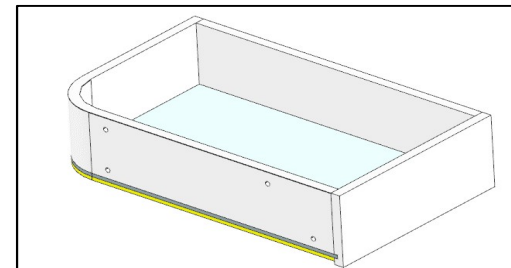

AZ26M

MOD PTP

REV. GR 9

| LOCALE | CODICE | DESCRIZIONE COMPONENTE | FINITURA | Q.TA | OPERATORE |
|-----------------|----------------|------------------------|------------------------|------|-----------|
| CABINA ARMATORE | AZ26M-L02_AI01 | COMODINO SX | LACCATO NCS S3020-Y30R | 6 | Damiano |

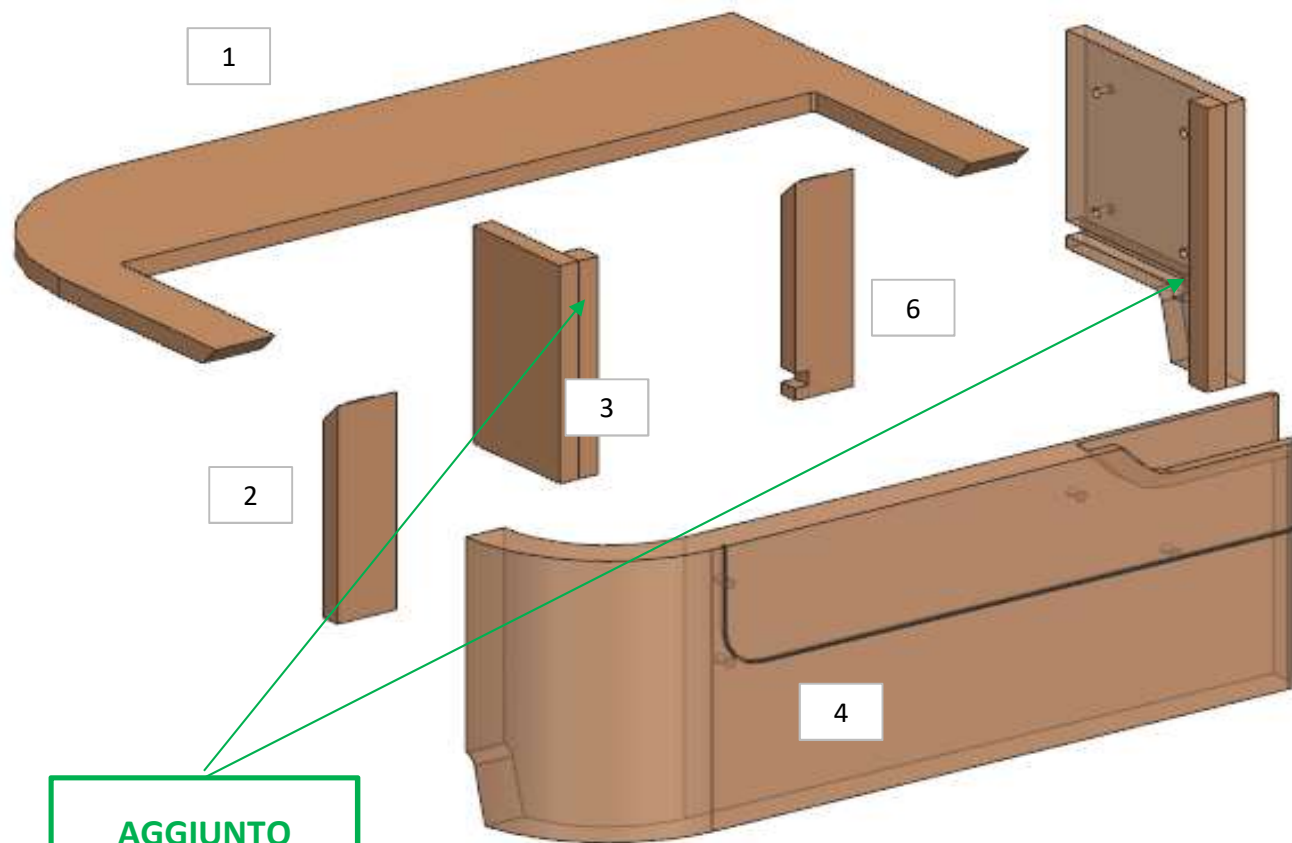

- 1 - L. 685 x H 341 x sp 16
- 2 - 6 - L. 50 x H 178 x sp 16
- 3 - L. 100 x H 178 x sp 16
- 4 - L. 623 x H 230 x sp 32
- 5 - L. 188 x H 232 x sp 16

ELEMENTO DA MONTARE con:
L01_AI01
AZ26M-AI01_01/02/03/04
e spedire con un unico imballo

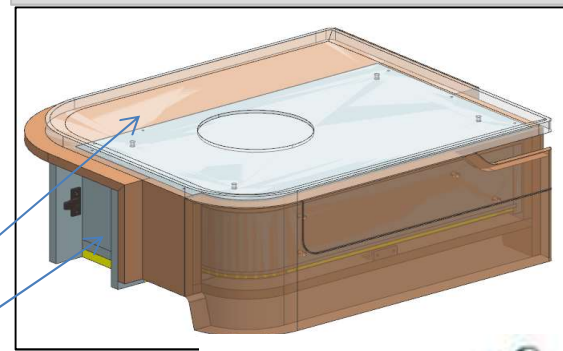

**AGGIUNTO
DENTELLI**

AZ26M

MOD PTP

REV. GR 9

| LOCALE | CODICE | DESCRIZIONE COMPONENTE | FINITURA | Q.TA | OPERATORE |
|-----------------|---------------|------------------------|----------|------|-----------|
| CABINA ARMATORE | AZ26M-MF_AI01 | COMODINO SX | | | Damiano |

CASSETTO
DIVENTATO
LACCATO

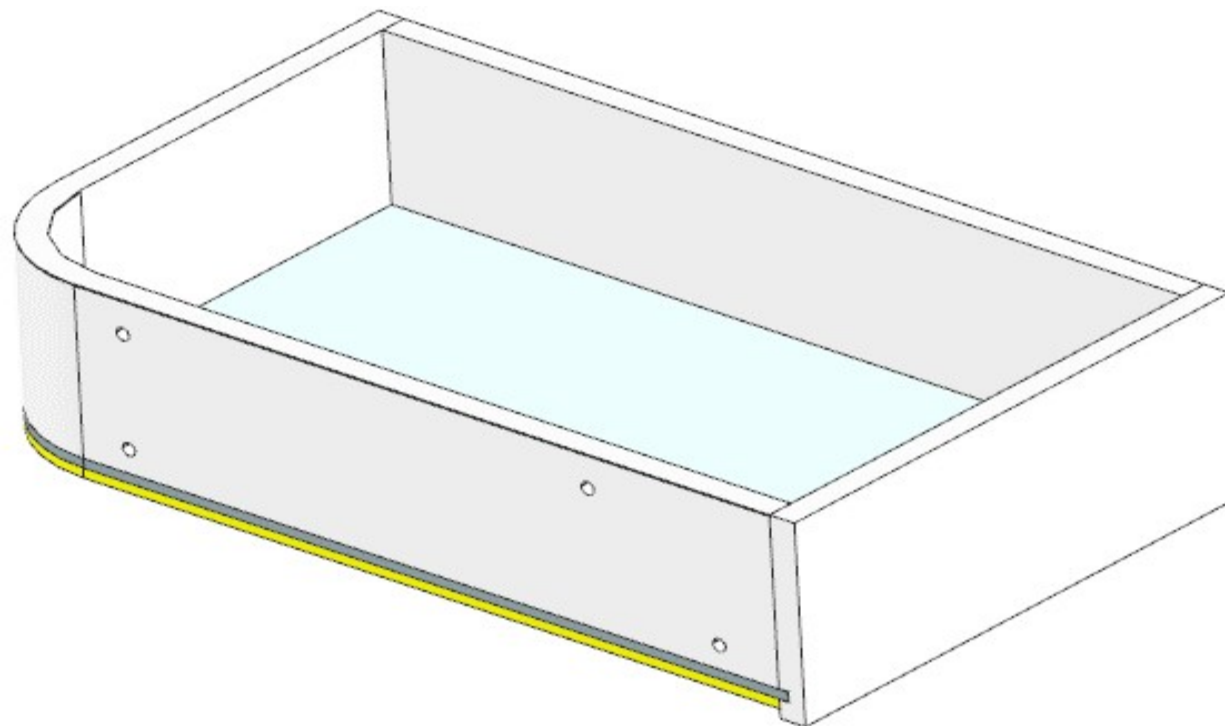

FERRAMENTA:

- N° 1 - GUIDA 250
- N° 2 - KEKU FRONTALE
- N° 1 - CALAMITA PER CASSETTI
- N° 22 - SPINA diam 8
- N° 2 - VITI 6MA

AZ26M

REV. GR 9

| LOCALE | CODICE | DESCRIZIONE COMPONENTE | FINITURA | Q.TA | OPERATORE |
|-----------------|----------------|------------------------|---------------|------|-----------|
| CABINA ARMATORE | AZ26M-R01_AJ01 | CIELINO INGRESSO | LASTRA CHIARA | 1 | Damiano |

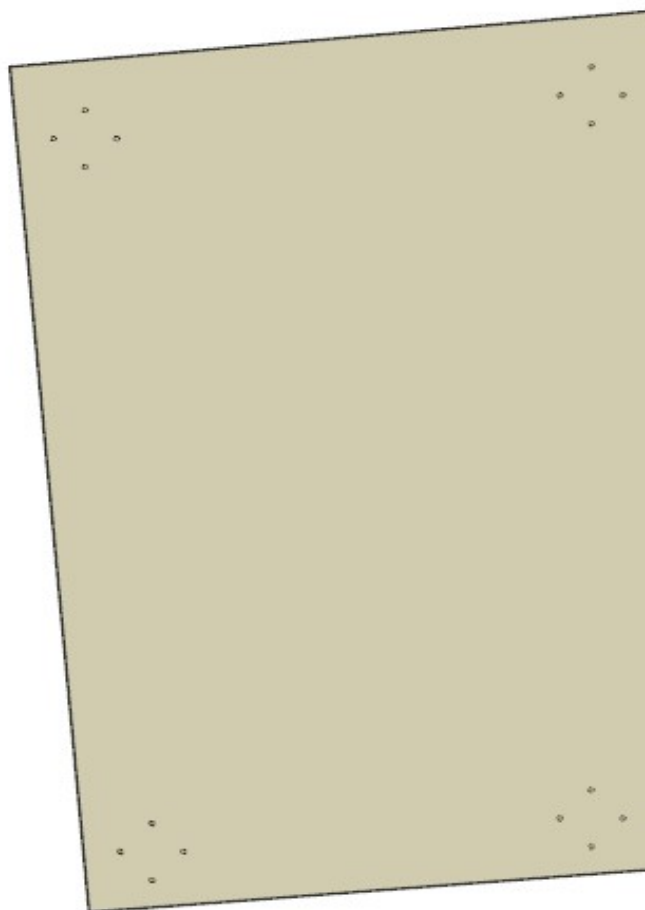

AZ26M

REV. GR 9

| LOCALE | CODICE | DESCRIZIONE COMPONENTE | FINITURA | Q.TA | OPERATORE |
|-----------------|------------|------------------------|----------------|------|-----------|
| CABINA ARMATORE | AZ26M-AK01 | GRADINI DISCESA PRUA | OKOUME' GREZZO | 2 | Dante |

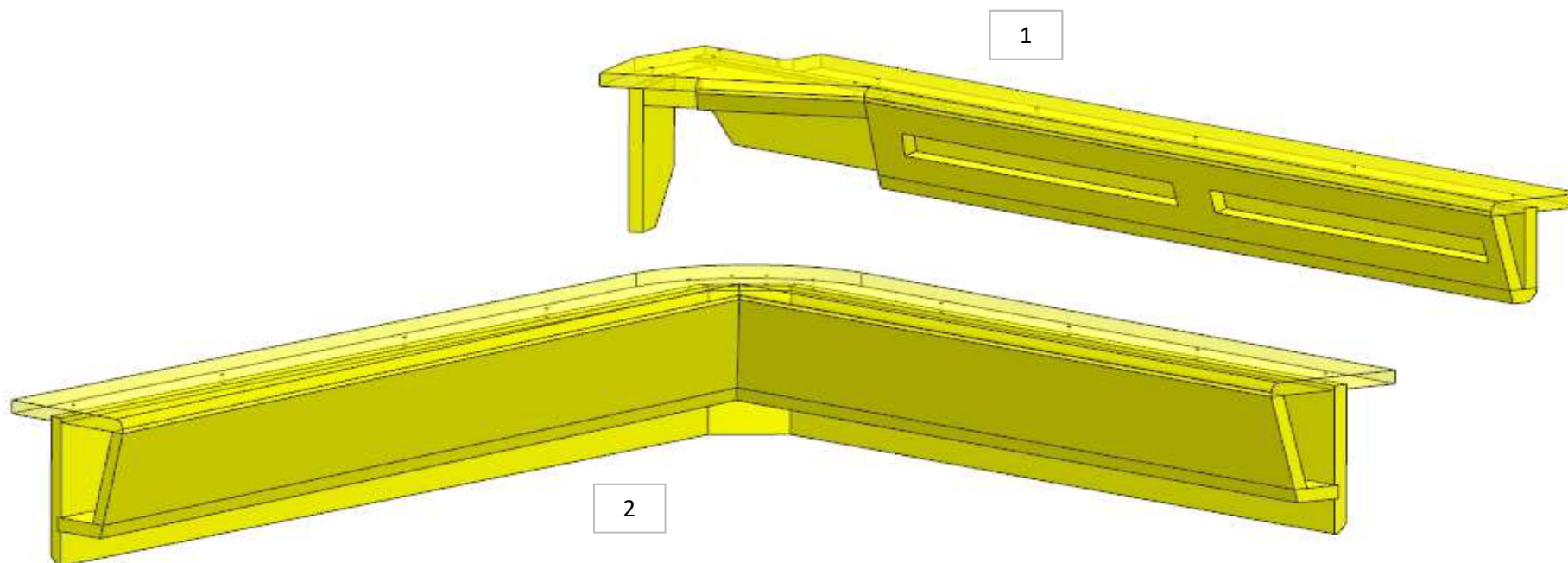

AZ26M

MOD PTP

REV. GR 9

| LOCALE | CODICE | DESCRIZIONE COMPONENTE | FINITURA | Q.TA | OPERATORE |
|-----------------|---------------|------------------------|----------|------|-----------|
| CABINA ARMATORE | AZ26M-MA_AL01 | COMODINO DX | | | |

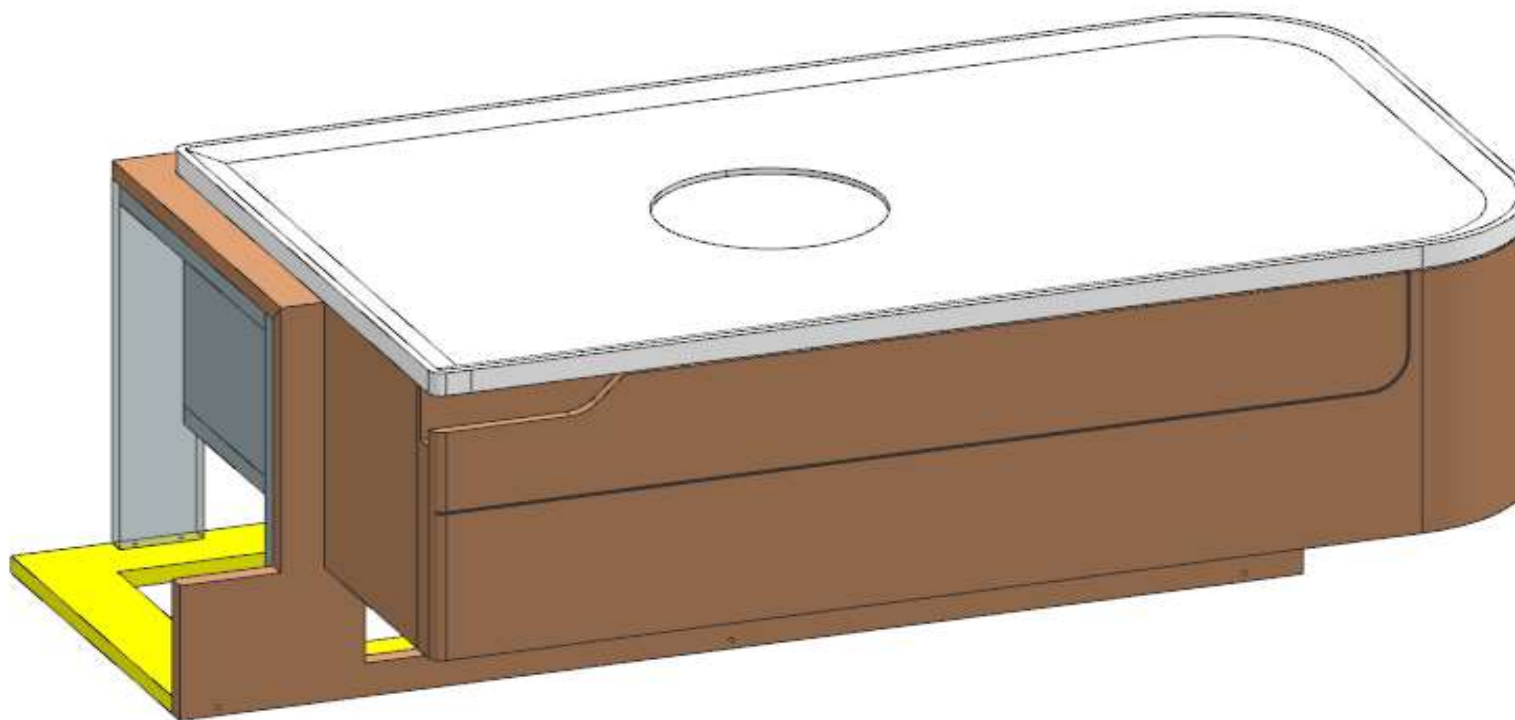

AZ26M

REV. GR 9

| LOCALE | CODICE | DESCRIZIONE COMPONENTE | FINITURA | Q.TA | OPERATORE |
|-----------------|------------|------------------------|----------------|------|-----------|
| CABINA ARMATORE | AZ26M-AL01 | COMODINO DX | LAMINATO NADIR | 4 | Damiano |

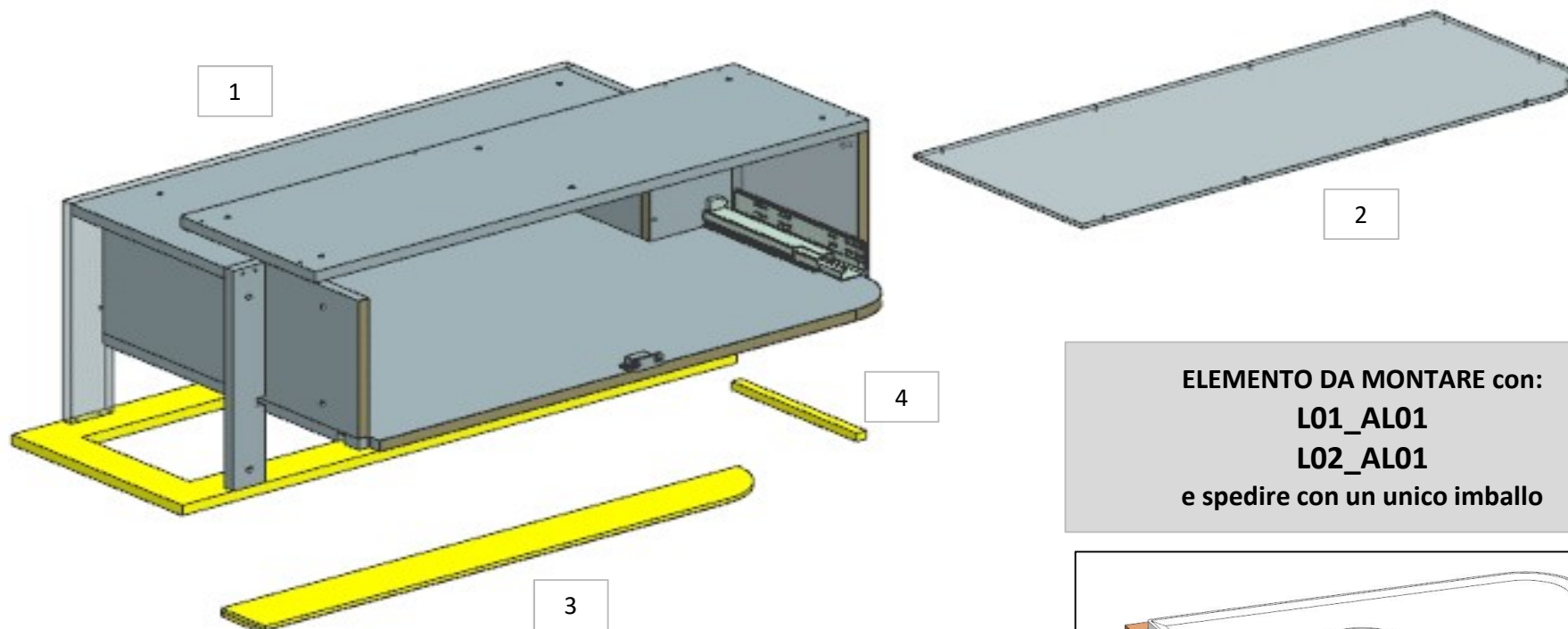

ELEMENTO DA MONTARE con:
L01_AL01
L02_AL01
 e spedire con un unico imballo

FERRAMENTA:

- N° 1 - GUIDA 250
- N° 1 - CALAMITA PER CASSETTI
- N° 24 - SPINA diam 8
- N° 2 - VITI 6MA

**MODIFICATO STRUTTURA
 INTERNA, CASSETTO
 INTERNO DIVENTATO
 LACCATO**

L01_AL01

L02_AL01

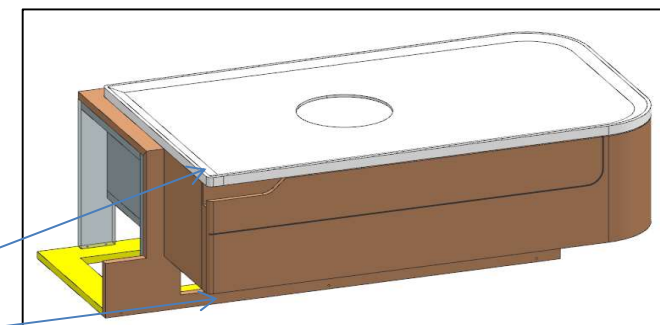

AZ26M

MOD PTP

REV. GR 9

| LOCALE | CODICE | DESCRIZIONE COMPONENTE | FINITURA | Q.TA | OPERATORE |
|-----------------|----------------|------------------------|-------------------------|------|-----------|
| CABINA ARMATORE | AZ26M-L01_AL01 | COMODINO DX | LACCATO BIANCO RAL 9016 | 6 | Damiano |

**CASSETTO INTERNO
DIVENTATO LACCATO**

- 1 - L. 895 x H 530 x sp 12
- 2 - L. 829 x H 103 x sp 16
- 3 - L. 805 x H 159 x sp 16
- 4 - L. 322 x H 177 x sp 16
- 5 - L. 291 x H 134 x sp 16
- 6 - L. 789 x H 159 x sp 16

ELEMENTO DA MONTARE con:
AL01_02/03/04
L01_AL01_03/04/05/06
e spedire con un unico imballo

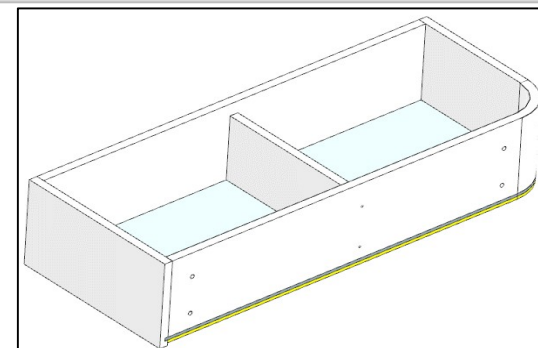
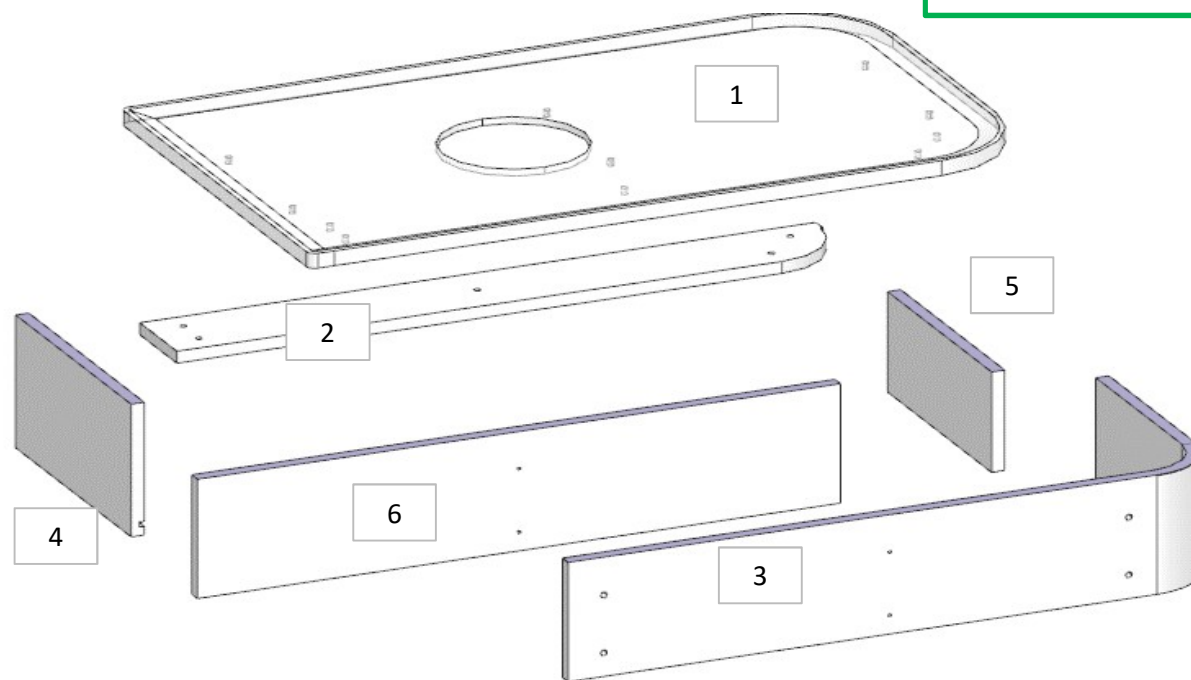

AZ26M

MOD PTP

REV. GR 9

| LOCALE | CODICE | DESCRIZIONE COMPONENTE | FINITURA | Q.TA | OPERATORE |
|-----------------|----------------|------------------------|------------------------|------|-----------|
| CABINA ARMATORE | AZ26M-L02_AL01 | COMODINO DX | LACCATO NCS S3020-Y30R | 6 | Damiano |

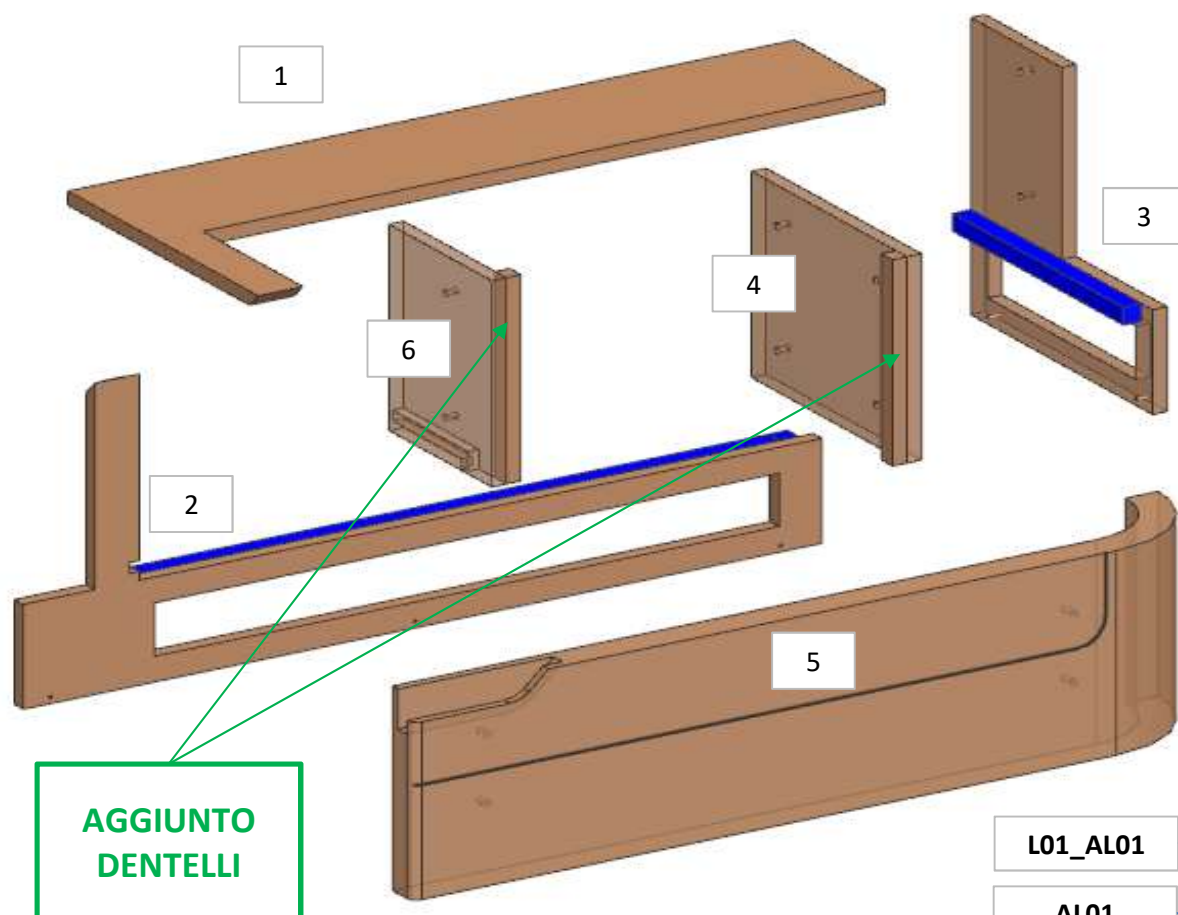

- 1 - L. 800 x H 341 x sp 16
- 2 - L. 880 x H 350 x sp 16
- 3 - L. 326 x H 334 x sp 16
- 4 - L. 279 x H 232 x sp 16
- 5 - SVILUPPO L. 991 x H 230 x sp 32
- 6 - L. 188 x H 232 x sp 16

ELEMENTO DA MONTARE con:
L01_AL01
AL01
 e spedire con un unico imballo

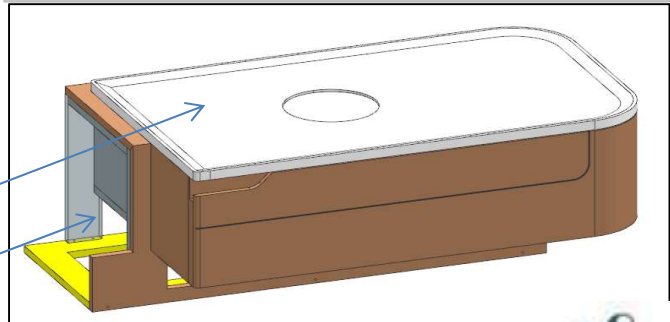

**AGGIUNTO
DENTELLI**

L01_AL01

AL01

AZ26M

MOD PTP

REV. GR 9

| LOCALE | CODICE | DESCRIZIONE COMPONENTE | FINITURA | Q.TA | OPERATORE |
|-----------------|---------------|------------------------|----------|------|-----------|
| CABINA ARMATORE | AZ26M-MF_AL01 | COMODINO DX | | | Damiano |

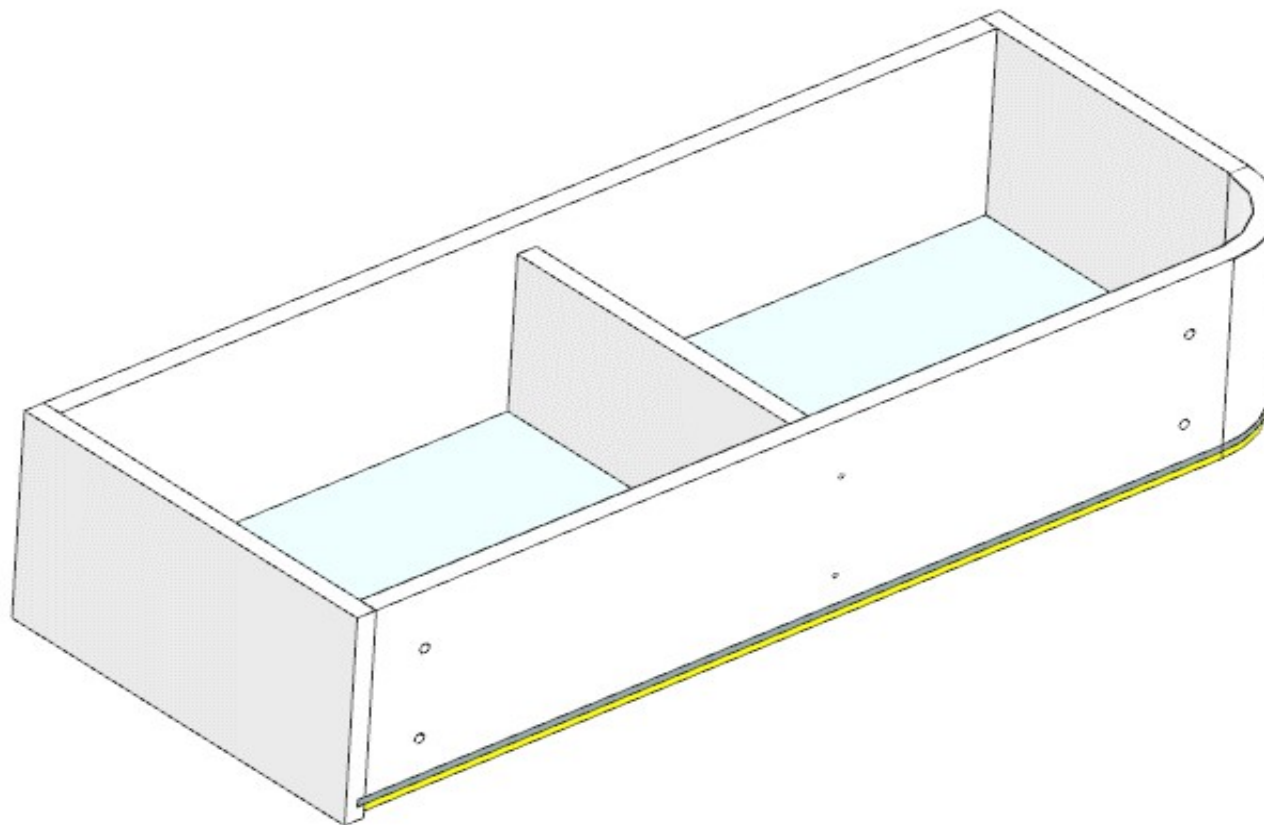

FERRAMENTA:

- N° 1 - GUIDA 250
- N° 1 - CALAMITA PER CASSETTI
- N° 24 - SPINA diam 8
- N° 2 - VITI 6MA

consonni&c

AZ26M

REV. GR 9

| LOCALE | CODICE | DESCRIZIONE COMPONENTE | FINITURA | Q.TA | OPERATORE |
|-----------------|------------|------------------------|----------------|------|-----------|
| CABINA ARMATORE | AZ26M-AL01 | COMODINO DX | LAMINATO NADIR | 4 | Damiano |

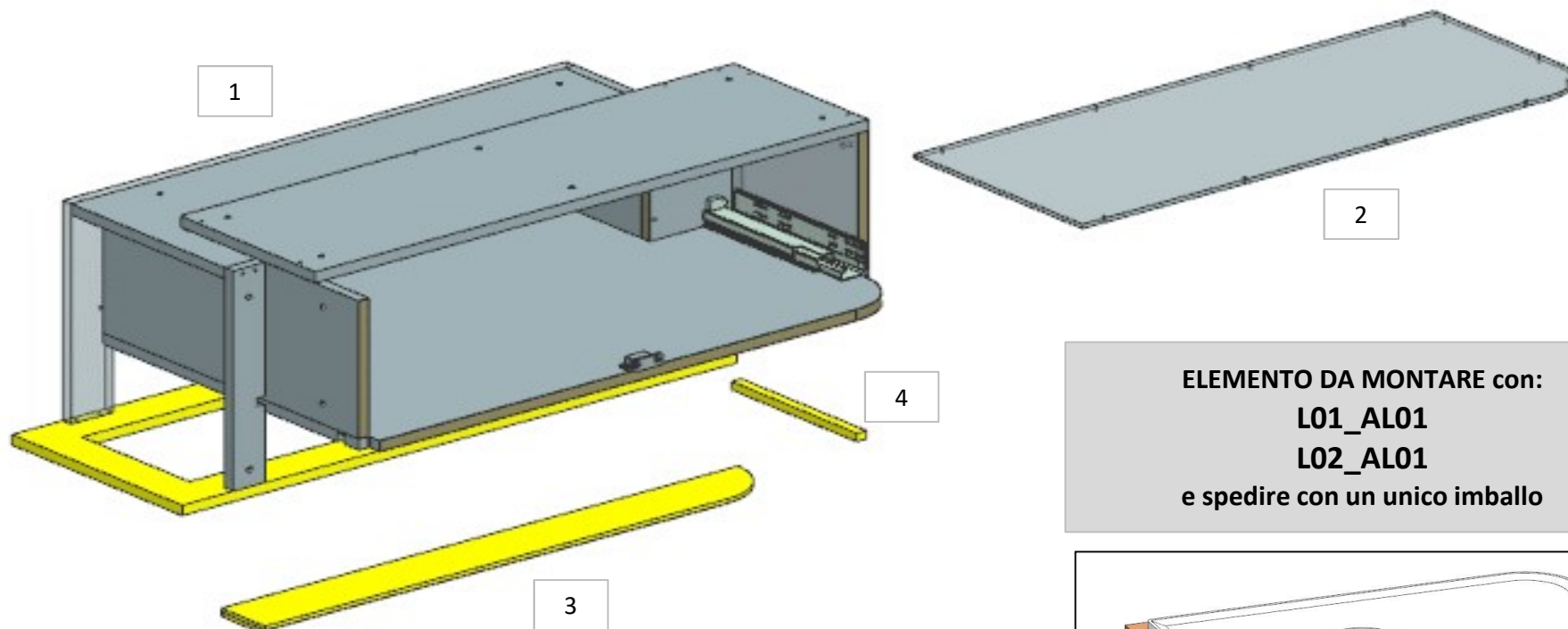

ELEMENTO DA MONTARE con:
L01_AL01
L02_AL01
 e spedire con un unico imballo

FERRAMENTA:

- N° 1 - GUIDA 250
- N° 1 - CALAMITA PER CASSETTI
- N° 24 - SPINA diam 8
- N° 2 - VITI 6MA

**MODIFICATO STRUTTURA
 INTERNA, CASSETTO
 INTERNO DIVENTATO
 LACCATO**

L01_AL01

L02_AL01

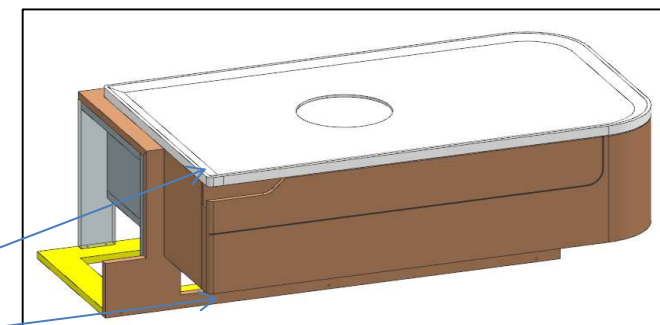

AZ26M

REV. GR 9

| LOCALE | CODICE | DESCRIZIONE COMPONENTE | FINITURA | Q.TA | OPERATORE |
|-----------------|----------------|------------------------|------------------------|------|-----------|
| CABINA ARMATORE | AZ26M-L01_AM01 | LETTO | LACCATO NCS S3020-Y30R | 3 | Damiano |

- 1 - L. 1565 x H 257 x sp 16
- 2 - L. 1313 x H 110 x sp 16
- 3 - L. 1686 x H 257 x sp 16

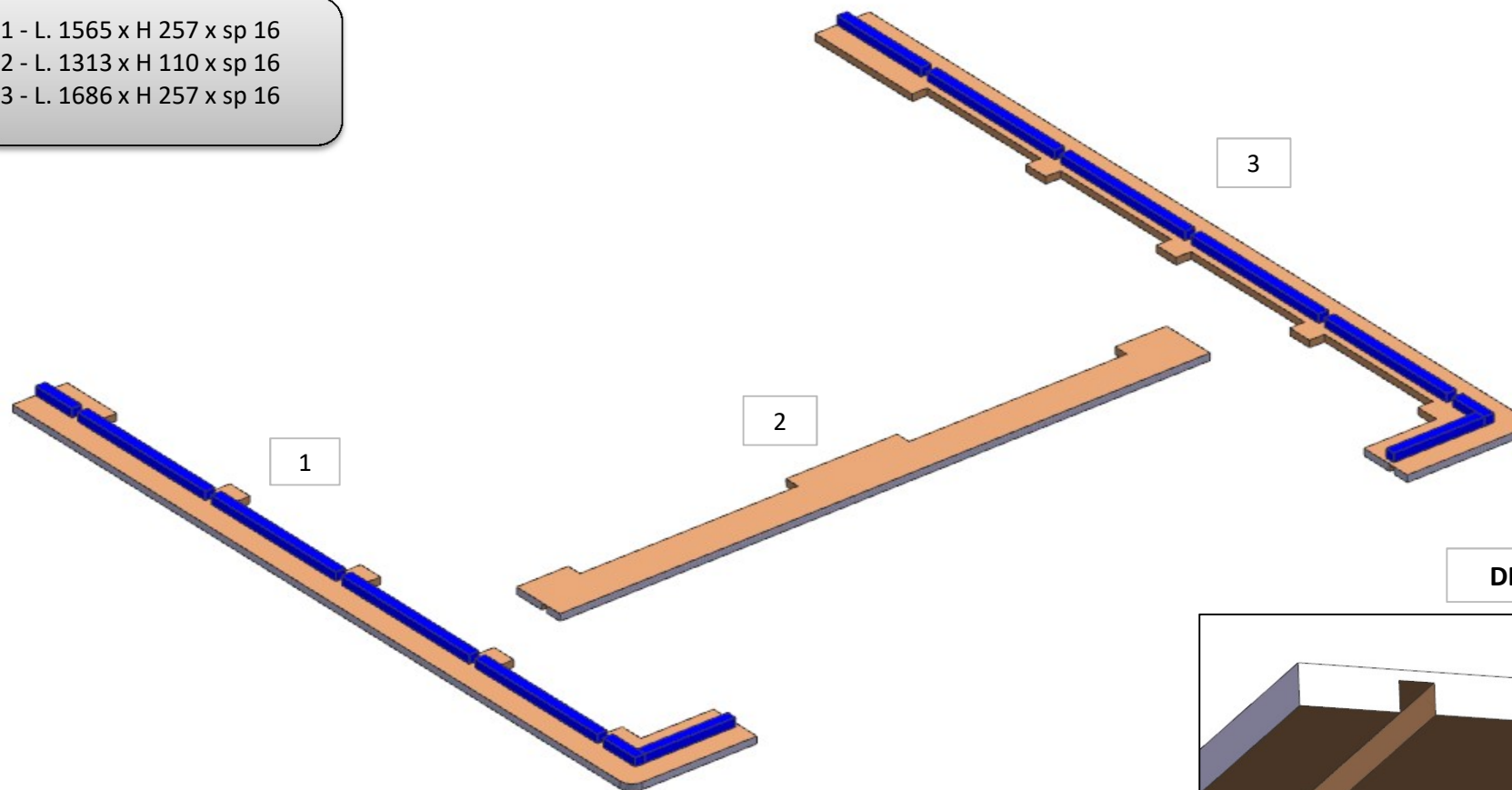

DETTAGLIO

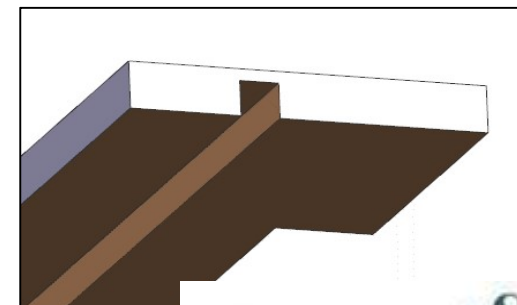

consonni&c

AZ26M

REV. 01-2023

REV. GR 9

| LOCALE | CODICE | DESCRIZIONE COMPONENTE | FINITURA | Q.TA | OPERATORE |
|-----------------|---------------|--|----------|------|-----------|
| CABINA ARMATORE | AZ26M-MG_AQ01 | ARMADIO DRESSING PRUA CENTRONAVE STD-VAR1 | | | Damiano |

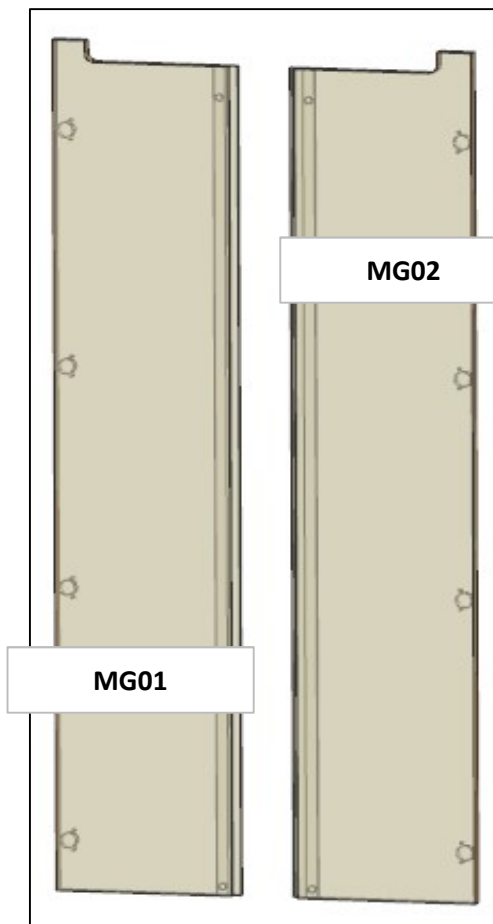

AZ26M

REV. 01-2023

REV. GR 9

| LOCALE | CODICE | DESCRIZIONE COMPONENTE | FINITURA | Q.TA | OPERATORE |
|-----------------|----------------|--|---------------|------|-----------|
| CABINA ARMATORE | AZ26M-R01_AQ01 | ARMADIO DRESSING PRUA CENTRONAVE STD-VAR1 | LASTRA CHIARA | 2 | Damiano |

1 - 2 - L 380 x H 1968 x sp 25
3 - 4 - L 53 x H 1918 x sp 6

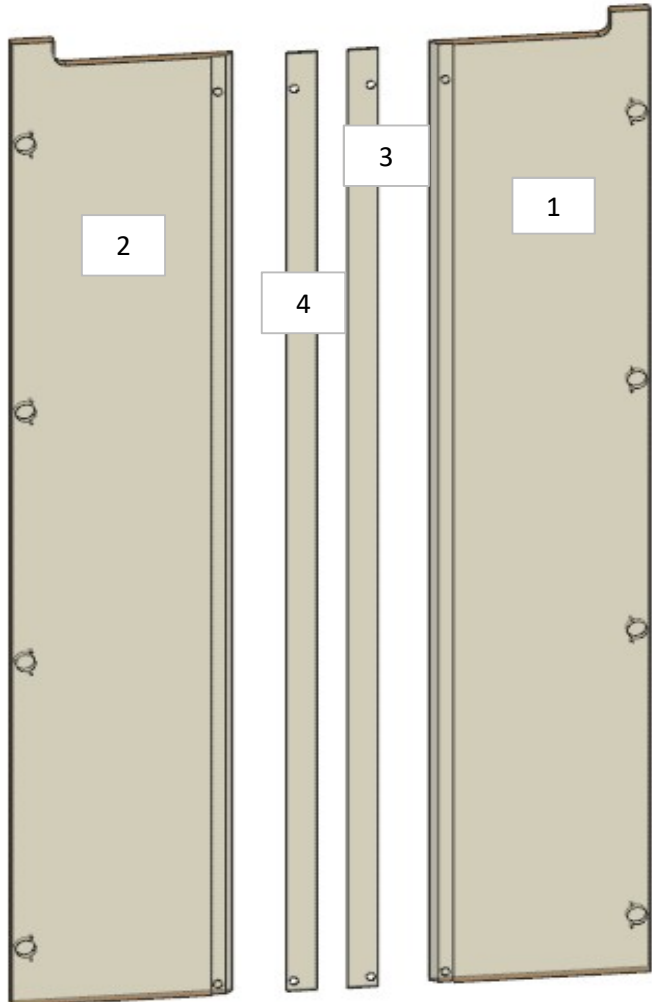

ELEMENTO DA MONTARE:
MG01
MG02
e spedire con un unico imballo

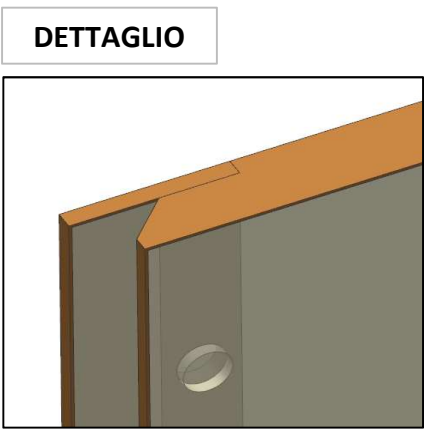

AZ26M

REV. GR 9

| LOCALE | CODICE | DESCRIZIONE COMPONENTE | FINITURA | Q.TA | OPERATORE |
|-----------------|----------------|------------------------------|---------------|------|-----------|
| CABINA ARMATORE | AZ26M-R01_AR01 | PLENUM ARMADIO PRUA STD-VAR1 | LASTRA CHIARA | 1 | Damiano |

1 - L 790 x H 30 x sp 25

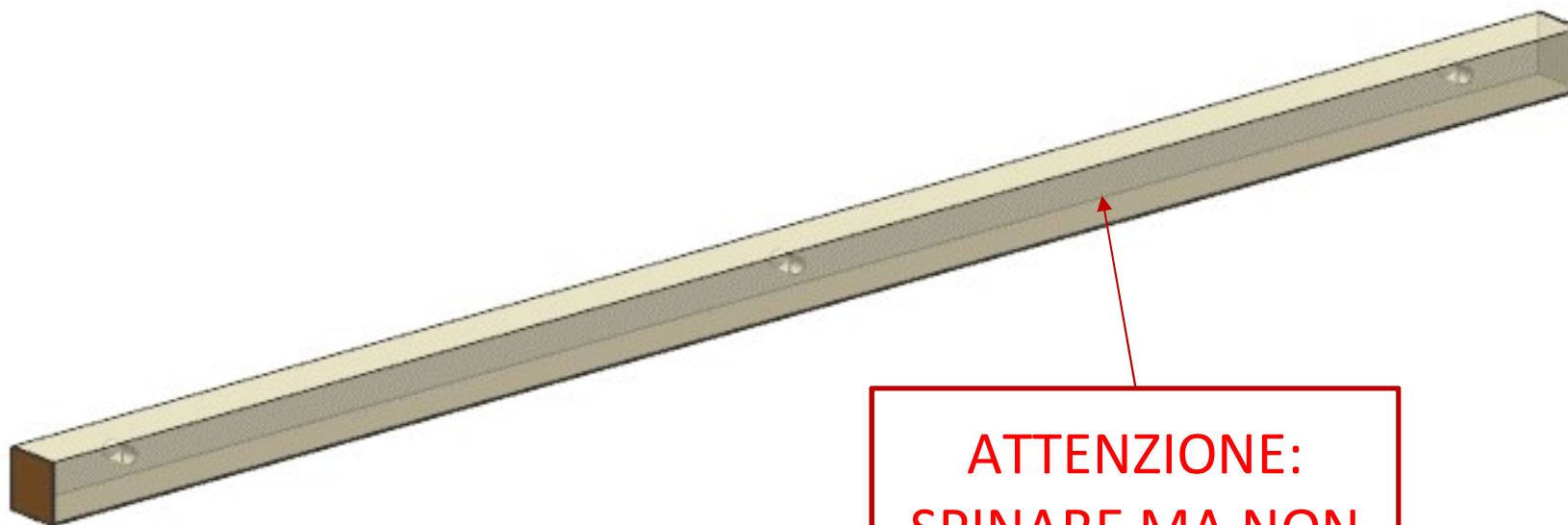

**ATTENZIONE:
SPINARE MA NON
INCOLLARE**

AZ26M

REV. GR 9

| LOCALE | CODICE | DESCRIZIONE COMPONENTE | FINITURA | Q.TA | OPERATORE |
|-----------------|----------------|------------------------------|--------------------------------------|------|-----------|
| CABINA ARMATORE | AZ26M-L01_AR01 | PLENUM ARMADIO PRUA STD-VAR1 | LACCATO BRONZO\ GREZZO VERNICIATO | 1 | Damiano |

1 - L 795 x H 164 x sp 16

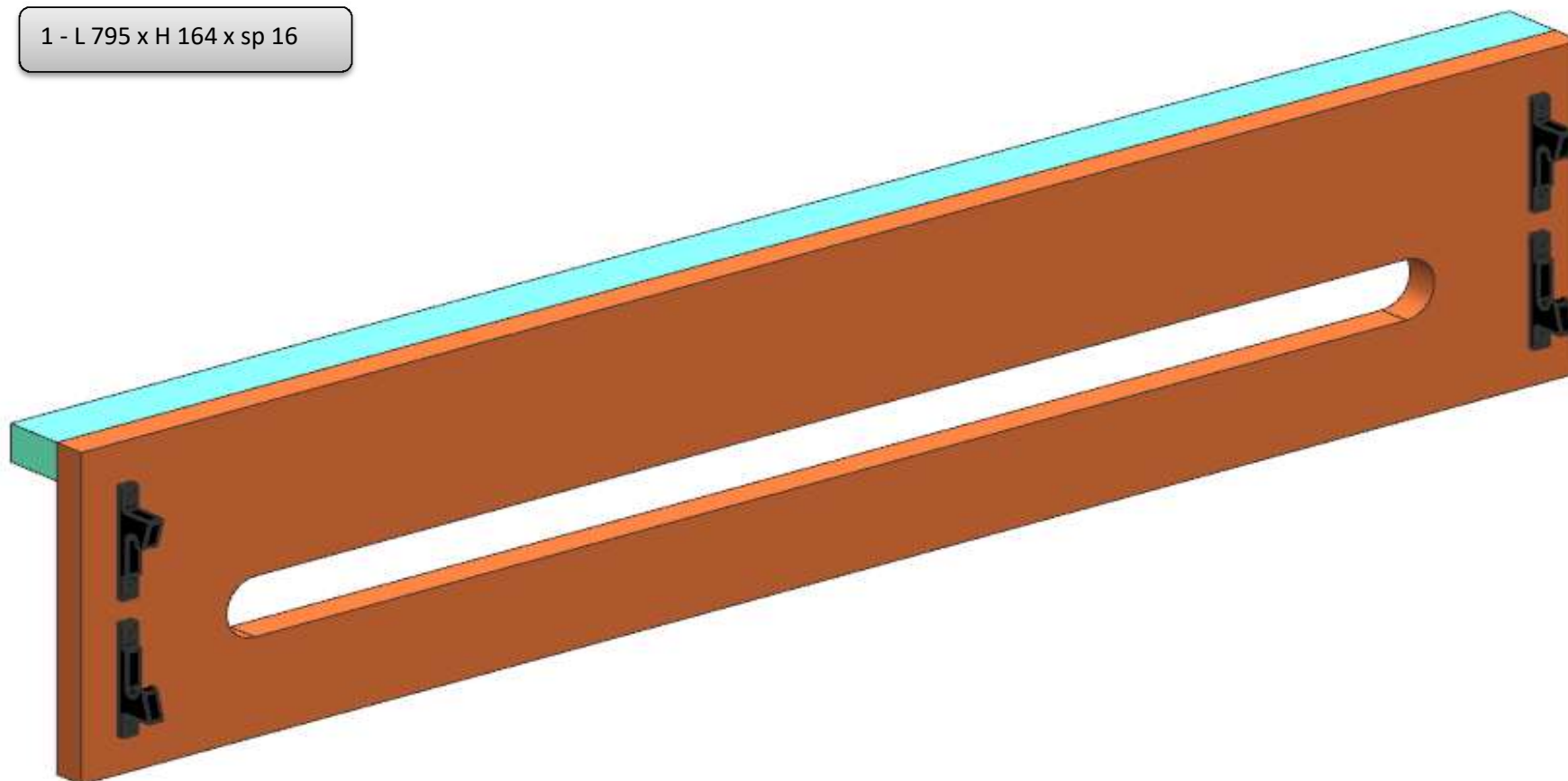

consonni&c

AZ26M

REV. 01-2023

REV. GR 9

| LOCALE | CODICE | DESCRIZIONE COMPONENTE | FINITURA | Q.TA | OPERATORE |
|-----------------|----------------|---------------------------------|---------------|------|-----------|
| CABINA ARMATORE | AZ26M-R01_AS01 | ARMADIO DRESSING MURATA DI PRUA | LASTRA CHIARA | 3 | Damiano |

- 1 - L. 424 x H 2063 x sp 16
- 2 - L. 279 x H 98 x sp 16
- 3 - L 98 x H 448 x sp 16

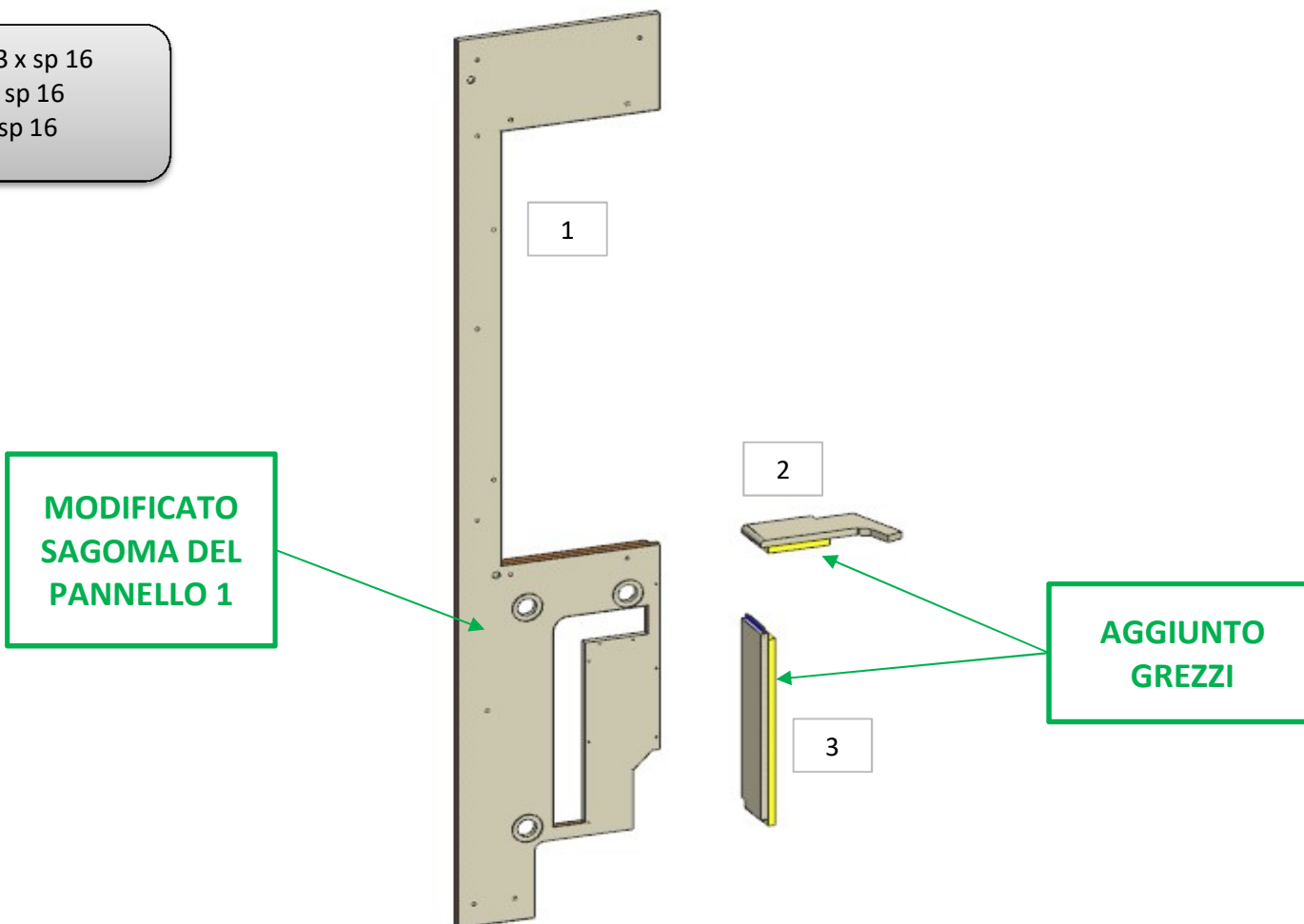

AZ26M

REV. 01-2023

REV. GR 9

| LOCALE | CODICE | DESCRIZIONE COMPONENTE | FINITURA | Q.TA | OPERATORE |
|-----------------|----------------|---------------------------------|-------------------------|------|-----------|
| CABINA ARMATORE | AZ26M-L01_AS01 | ARMADIO DRESSING MURATA DI PRUA | LACCATO BIANCO RAL 9010 | 3 | Damiano |

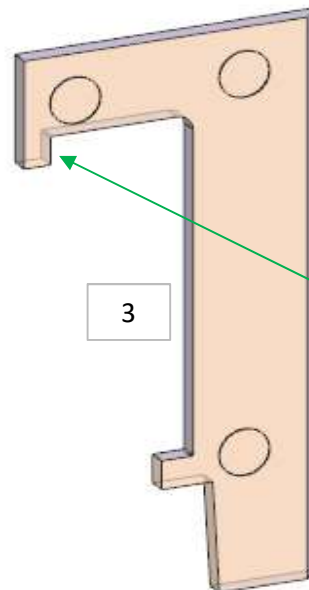
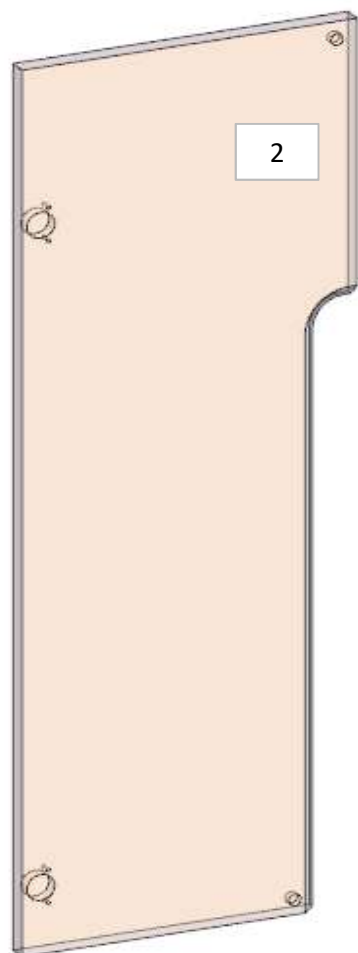

- 1 - L. 420 x H 30 x sp 25
- 2 - L. 420 x H 1204 x sp 25
- 3 - L. 372 x H 762 x sp 25

**ATTENZIONE:
SPINARE MA NON
INCOLLARE**

**AGGIUNTO
DENTELLO**

AZ26M

MOD PTP

REV. GR 9

| LOCALE | CODICE | DESCRIZIONE COMPONENTE | FINITURA | Q.TA | OPERATORE |
|-----------------|------------|---------------------------|----------------|------|-----------|
| CABINA ARMATORE | AZ26M-AT01 | CASSETTIERA DRESSING PRUA | LAMINATO NADIR | 1 | Damiano |

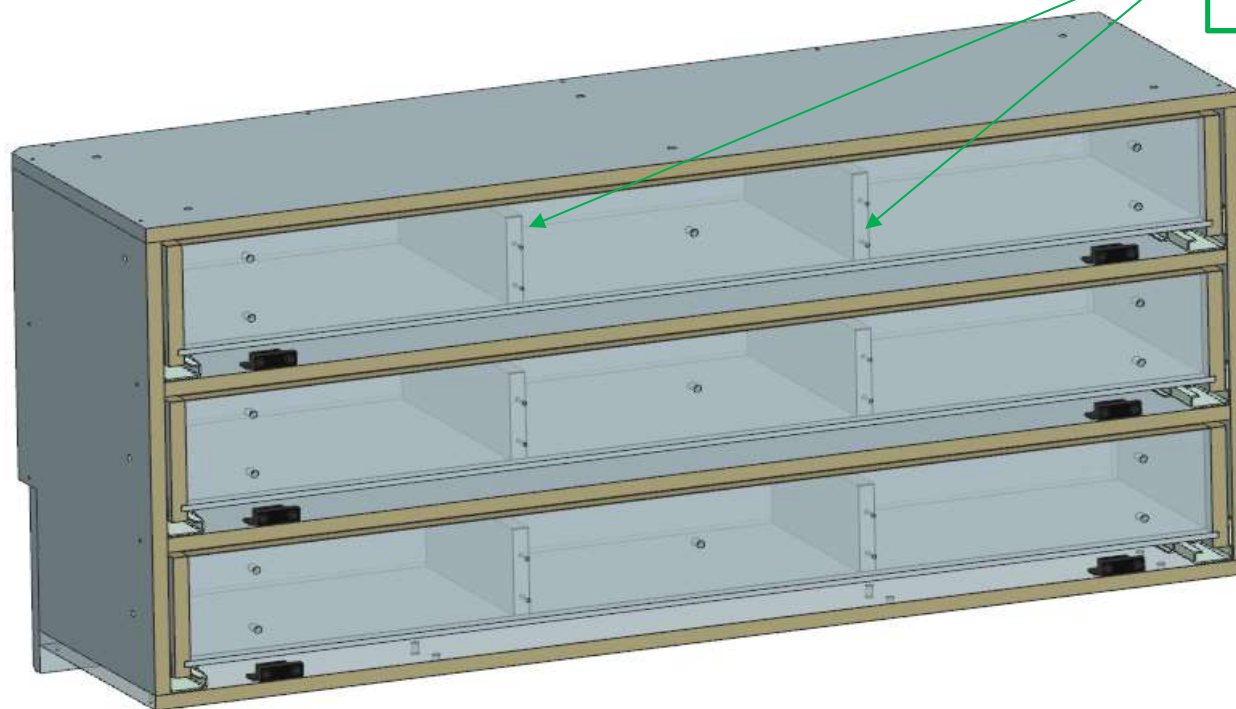

AGGIUNTI 2 DIVISORI
PER OGNI CASSETTO

AZ26M

REV. GR 9

| LOCALE | CODICE | DESCRIZIONE COMPONENTE | FINITURA | Q.TA | OPERATORE |
|-----------------|----------------|---------------------------|---------------|------|-----------|
| CABINA ARMATORE | AZ26M-R01_AT01 | CASSETTIERA DRESSING PRUA | LASTRA CHIARA | 5 | Damiano |

- 1 - L. 338 x H 528 x 120
- 2 - 3 - L. 1126 x H 174 x sp 20
- 4 - L. 1126 x H 171 x sp 20
- 5 - L 186 x H 528 x 126

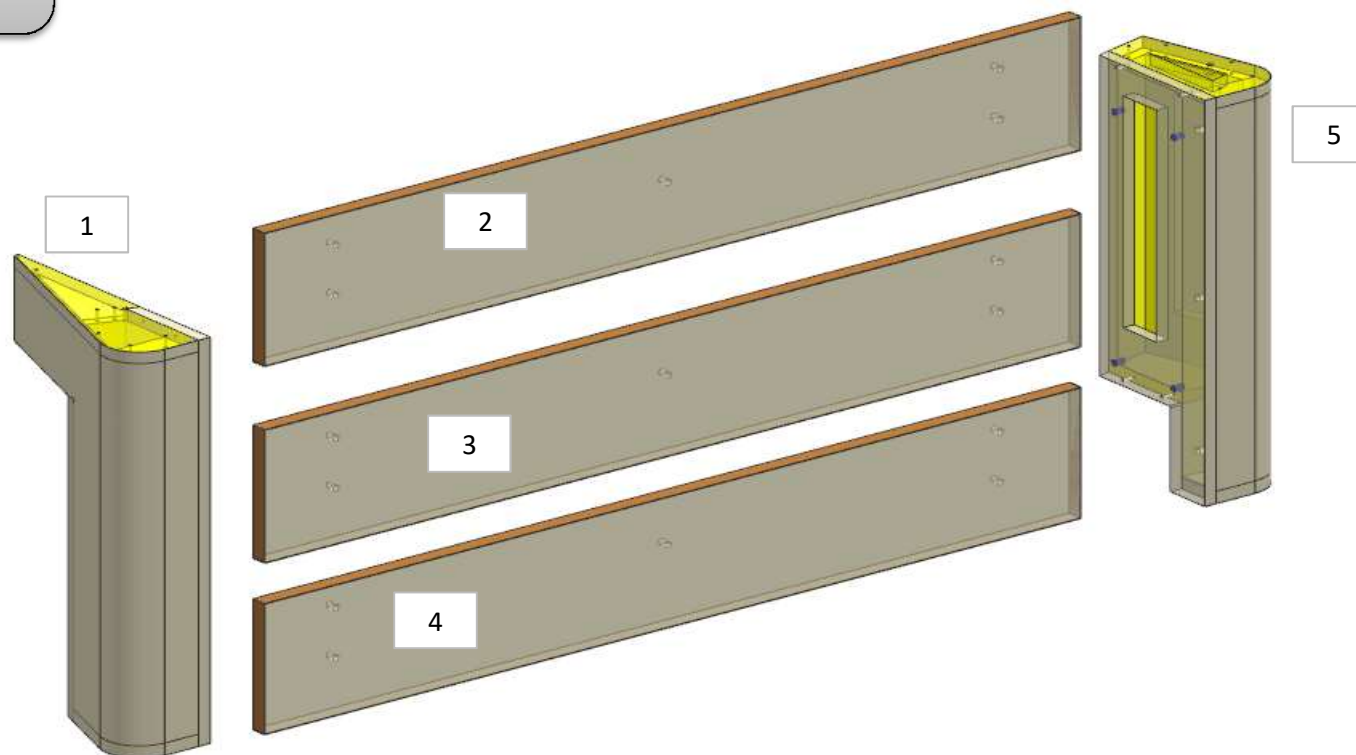

AZ26M

REV. GR 9

| LOCALE | CODICE | DESCRIZIONE COMPONENTE | FINITURA | Q.TA | OPERATORE |
|-----------------|----------------|---------------------------|-------------------------|------|-----------|
| CABINA ARMATORE | AZ26M-L01_AT01 | CASSETTIERA DRESSING PRUA | LACCATO BIANCO RAL 9010 | 2 | Damiano |

2 - L. 1310 x H 190 x 31

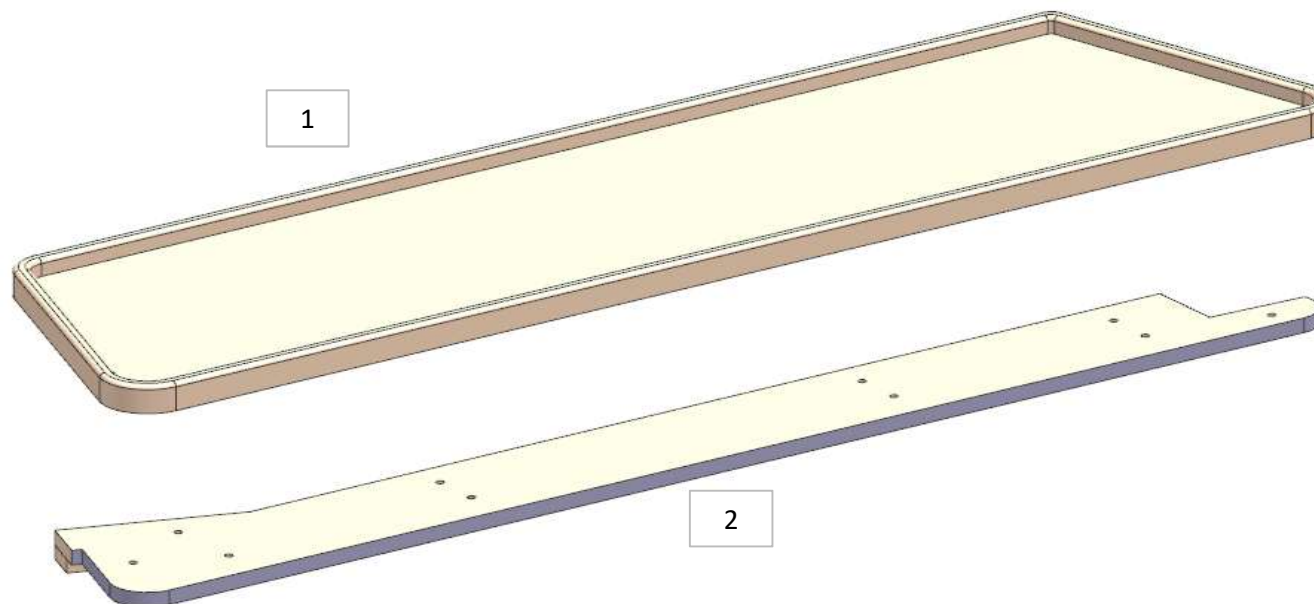

consonni&c

AZ26M

REV. GR 9

| LOCALE | CODICE | DESCRIZIONE COMPONENTE | FINITURA | Q.TA | OPERATORE |
|-----------------|-------------------|---------------------------|----------------|------|-----------|
| CABINA ARMATORE | AZ26M-L02_AT01_01 | CASSETTIERA DRESSING PRUA | LACCATO BRONZO | 1 | Damiano |

1 - 2 - 3 - DIAMETRO 20 x L 380

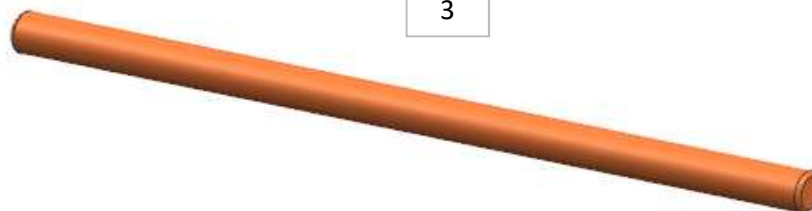
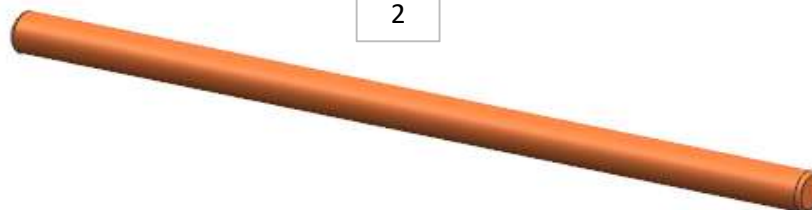
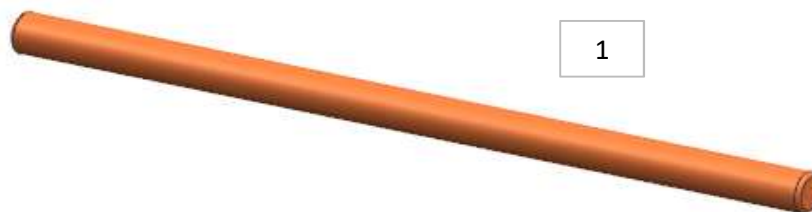

consonni&c

AZ26M

REV. GR 9

| LOCALE | CODICE | DESCRIZIONE COMPONENTE | FINITURA | Q.TA | OPERATORE |
|-----------------|----------------|------------------------|----------------|------|-----------|
| CABINA ARMATORE | AZ26M-L01_AU01 | PLENUM MURATA SX POPPA | LACCATO BRONZO | 1 | Damiano |

1 - L. 1950 x H 96 x 28

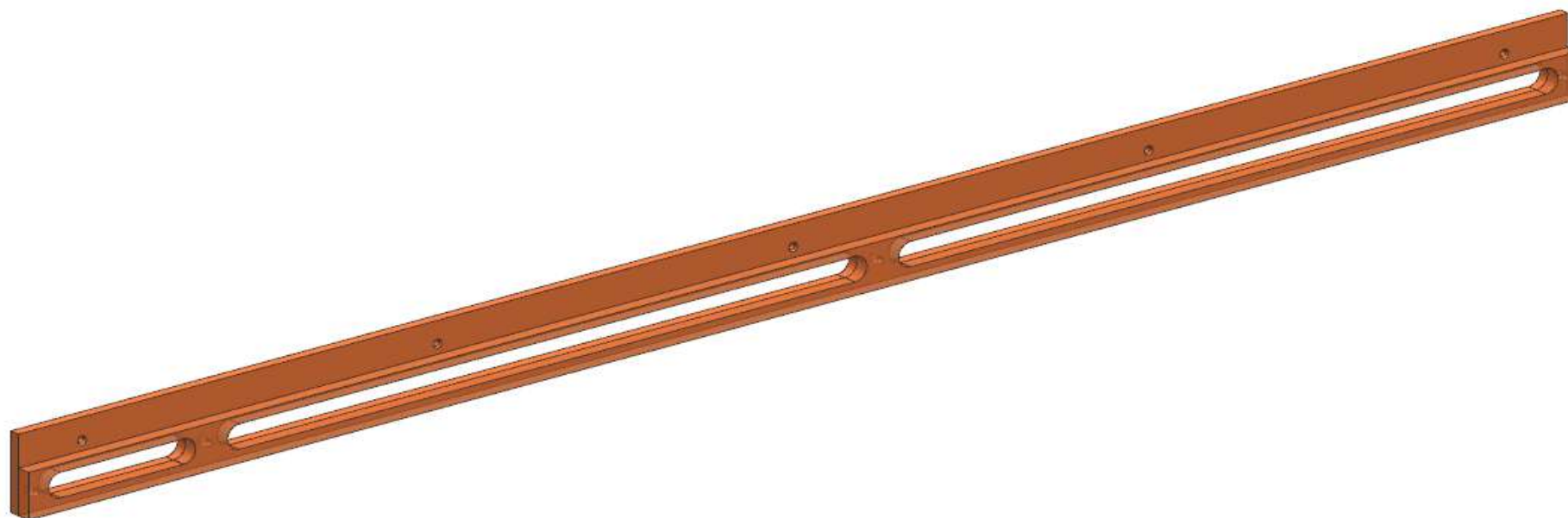

AZ26M

REV. GR 9

| LOCALE | CODICE | DESCRIZIONE COMPONENTE | FINITURA | Q.TA | OPERATORE |
|-----------------|----------------|------------------------|----------------|------|-----------|
| CABINA ARMATORE | AZ26M-L01_AV01 | PLENUM MURATA DX POPPA | LACCATO BRONZO | 1 | Damiano |

1 - L. 1242 x H 96 x 28

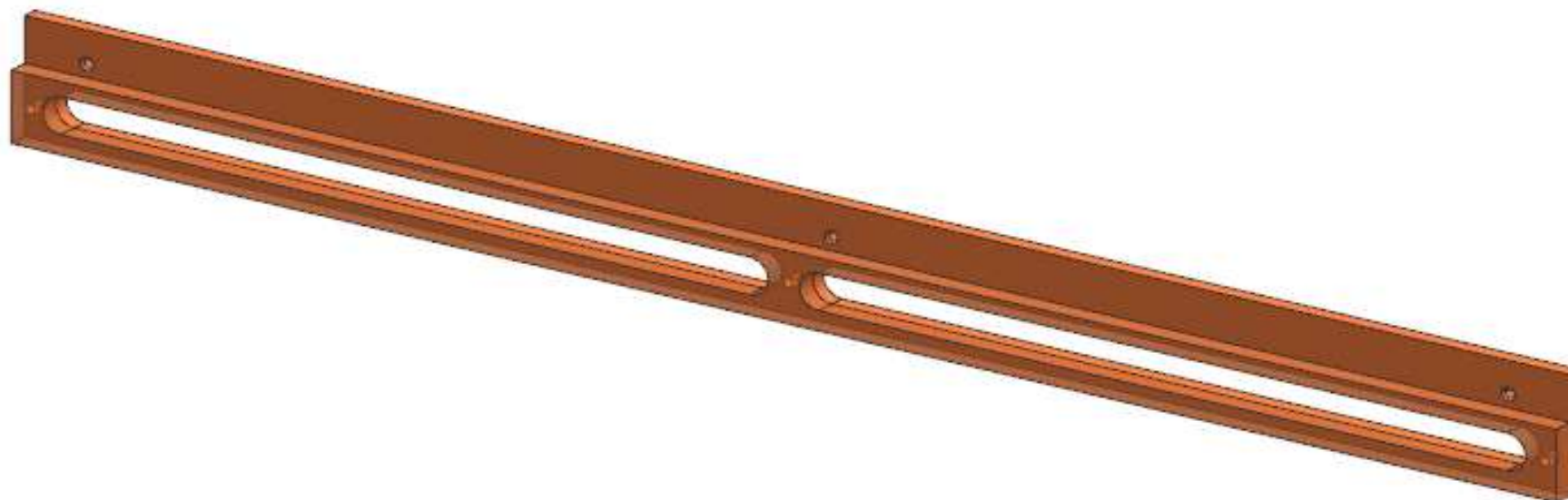

consonni&c

AZ26M

MOD PTP

REV. GR 9

| LOCALE | CODICE | DESCRIZIONE COMPONENTE | FINITURA | Q.TA | OPERATORE |
|-----------------|----------------|------------------------|-------------------------|------|-----------|
| CABINA ARMATORE | AZ26M-L01_AW01 | CIELINO MURATA PRUA DX | LACCATO BIANCO RAL 9016 | 2 | Damiano |

- 1 - L. 1242 x H 455 x sp 10
- 2 - L. 686 x H 1153 x sp 10

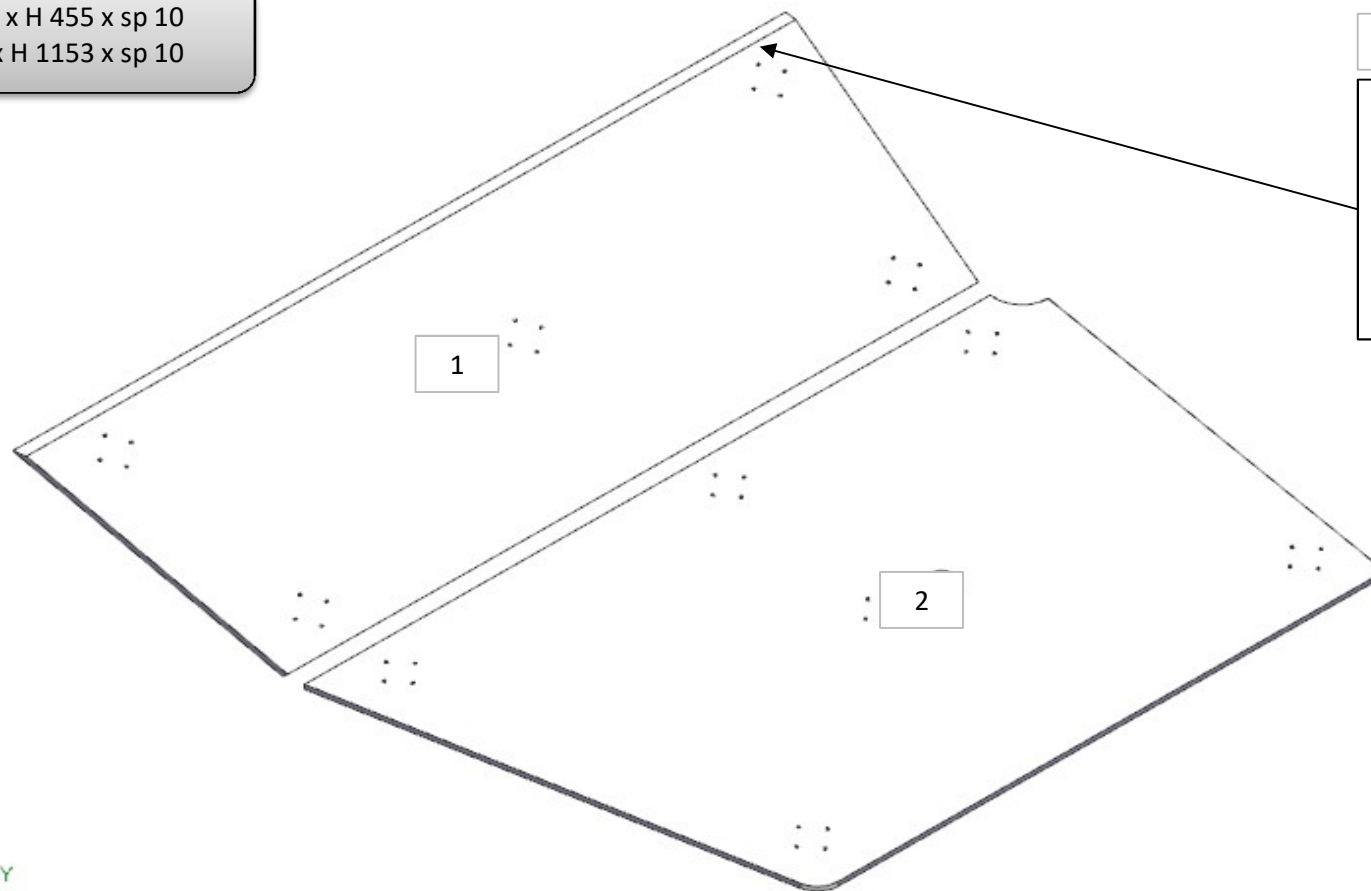

AGGIUNTO
FORO FARETTO

AZ26M

REV. GR 9

| LOCALE | CODICE | DESCRIZIONE COMPONENTE | FINITURA | Q.TA | OPERATORE |
|-----------------|----------------|--|----------|------|-----------|
| CABINA ARMATORE | AZ26M-MG_AAQ01 | ARMADIO DRESSING PRUA CENTRONAVE STD-VAR2 | | 1 | Damiano |

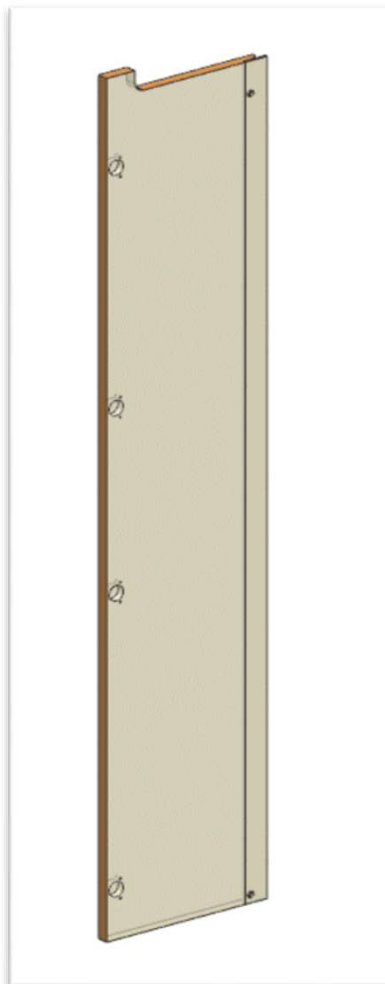

AZ26M

REV. GR 9

| LOCALE | CODICE | DESCRIZIONE COMPONENTE | FINITURA | Q.TA | OPERATORE |
|-----------------|-----------------|--|---------------|------|-----------|
| CABINA ARMATORE | AZ26M-R01_AAQ01 | ARMADIO DRESSING PRUA CENTRONAVE STD-VAR2 | LASTRA CHIARA | 2 | Damiano |

1 - L 377 x H 1968 x sp 25

ELEMENTO DA
MONTARE:
MG_AAQ01
e spedire con un unico
imballo

DETTAGLIO

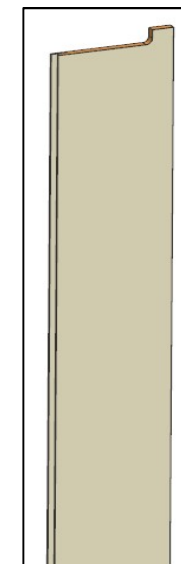
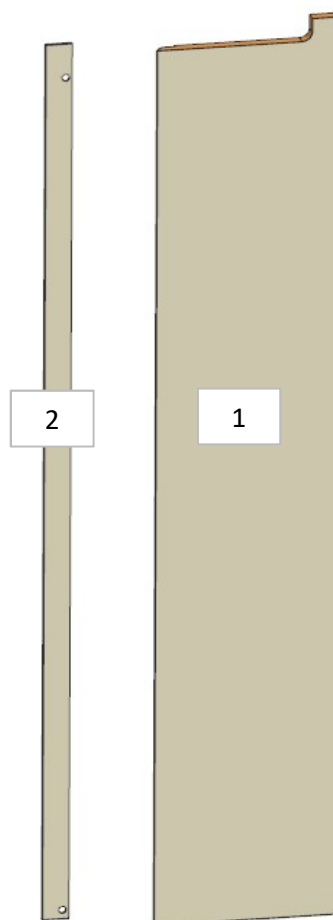
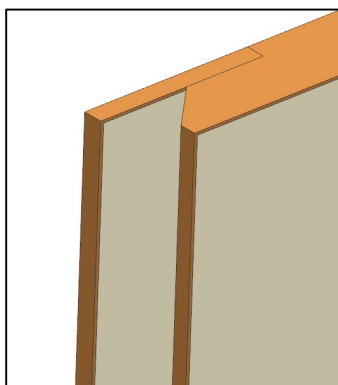

consonni&c

AZ26M

REV. GR 9

| LOCALE | CODICE | DESCRIZIONE COMPONENTE | FINITURA | Q.TA | OPERATORE |
|-----------------|-----------------|------------------------------|---------------|------|-----------|
| CABINA ARMATORE | AZ26M-R01_AAR01 | PLENUM ARMADIO PRUA STD-VAR2 | LASTRA CHIARA | 1 | Damiano |

1 - L 790 x H 30 x sp 25

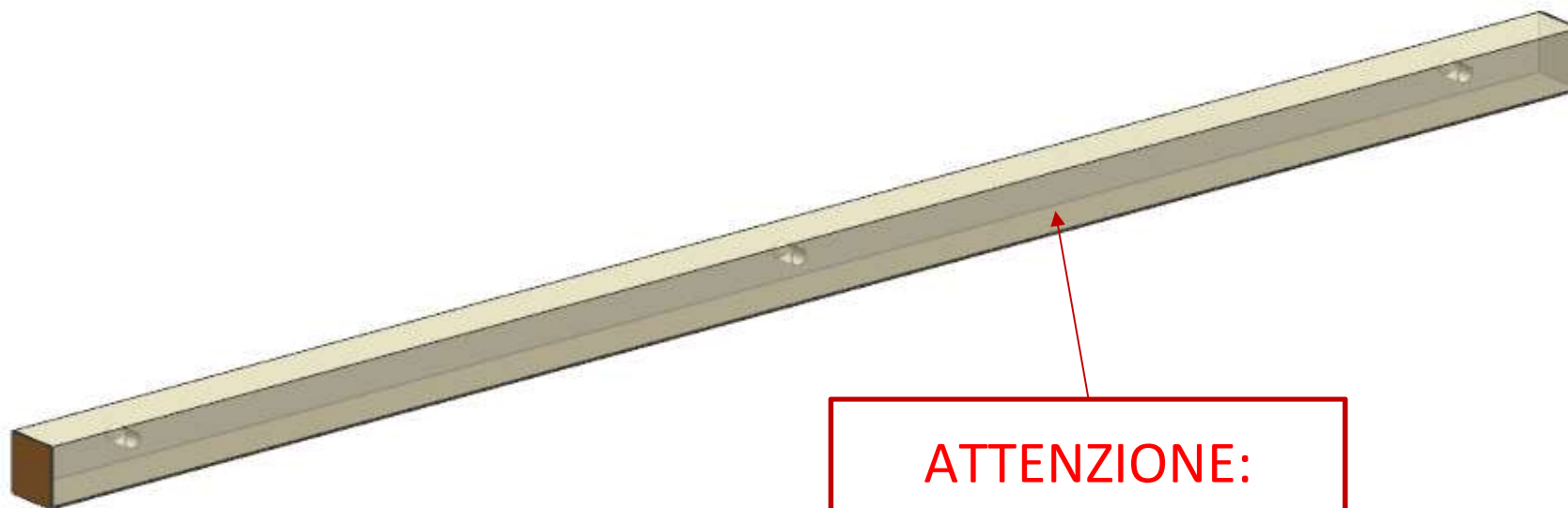

**ATTENZIONE:
SPINARE MA NON
INCOLLARE**

AZ26M

REV. GR 9

| LOCALE | CODICE | DESCRIZIONE COMPONENTE | FINITURA | Q.TA | OPERATORE |
|-----------------|-----------------|------------------------------|---|------|-----------|
| CABINA ARMATORE | AZ26M-L01_AAR01 | PLENUM ARMADIO PRUA STD-VAR2 | LACCATO BRONZO\ GREZZO VERNICIATO ANTI | 1 | Damiano |

1 - L.795 x H 144 x sp 16

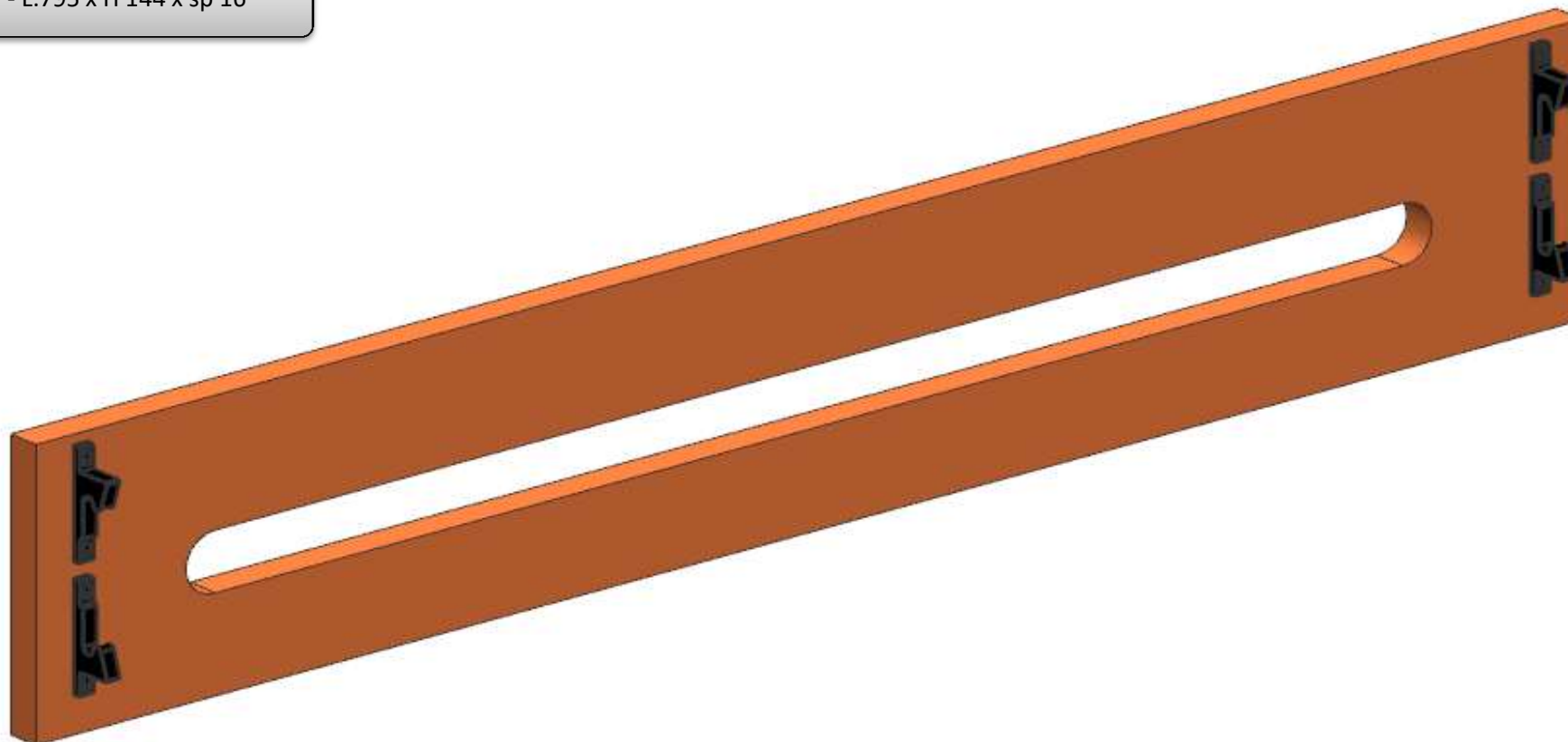

consonni&c

AZ26M

DA MAT 12

REV. GR 9

| LOCALE | CODICE | DESCRIZIONE COMPONENTE | FINITURA | Q.TA | OPERATORE |
|-----------------|----------------------|------------------------|----------|------|-----------|
| CABINA ARMATORE | AZ26M-MF_AAU01\AAU02 | SCRIVANIA VANITY | | 1 | Damiano |

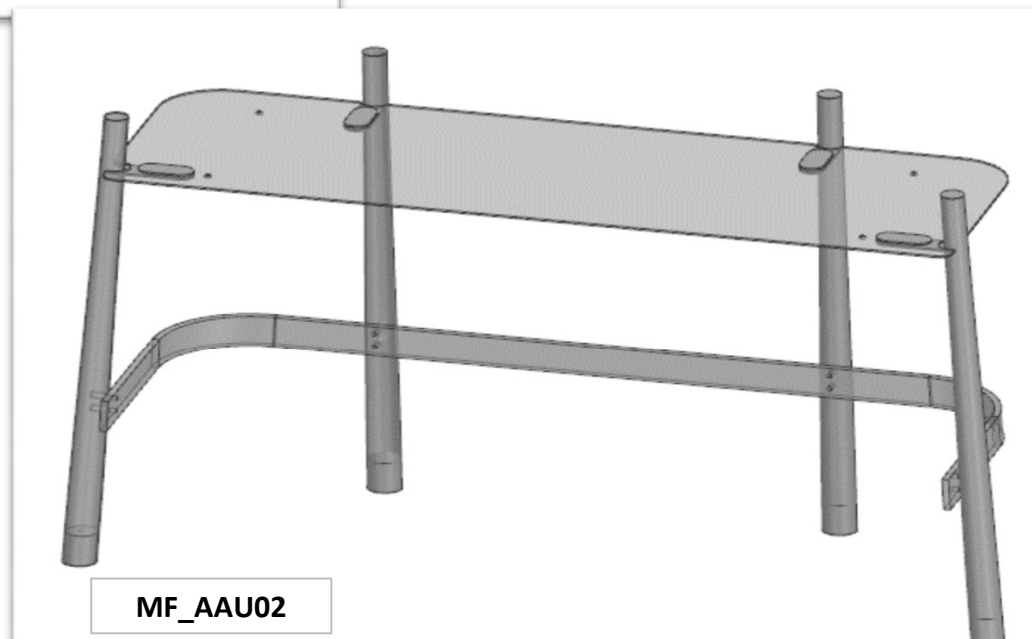
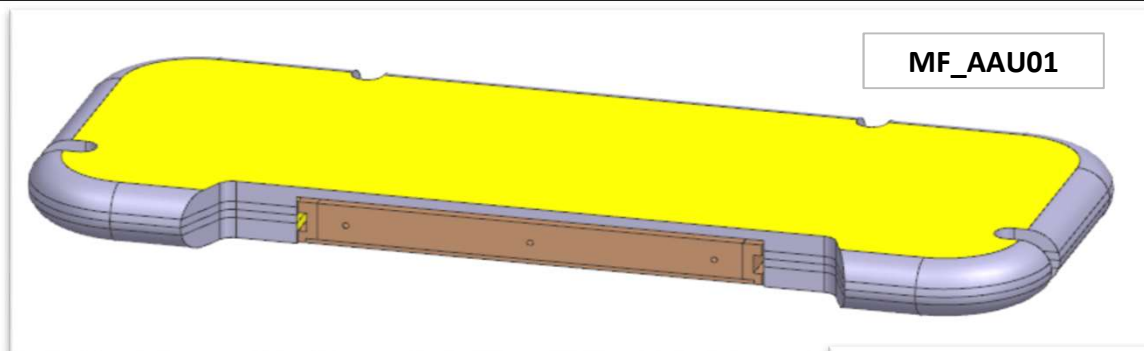

FERRAMENTA:

N° 2 - CALAMITE PER CASSETTI
N° 2 - GUIDE ACCURRIDE 250
codice 322683
BUSSOLA ZAMA

AZ26M

DA MAT 12

REV. GR 9

| LOCALE | CODICE | DESCRIZIONE COMPONENTE | FINITURA | Q.TA | OPERATORE |
|-----------------|-----------------|------------------------|------------------------------|------|-----------|
| CABINA ARMATORE | AZ26M-L01_AAU01 | SCRIVANIA VANITY | LACCATO LUMEN NCS S0502-Y | 1 | Damiano |

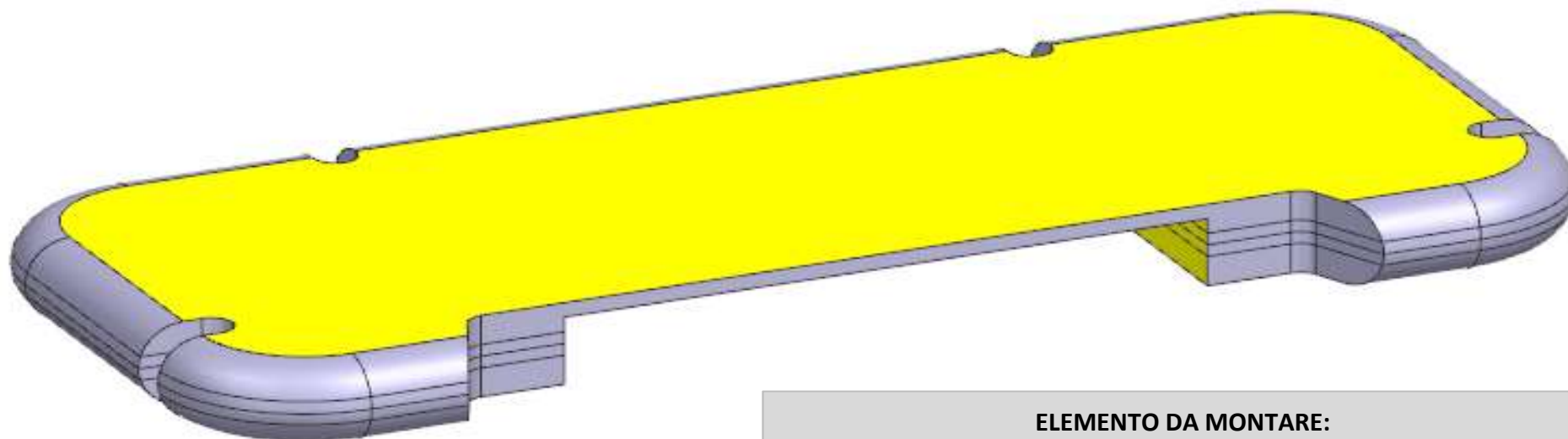

ELEMENTO DA MONTARE:
L02_AAU01
e spedire con un unico imballo

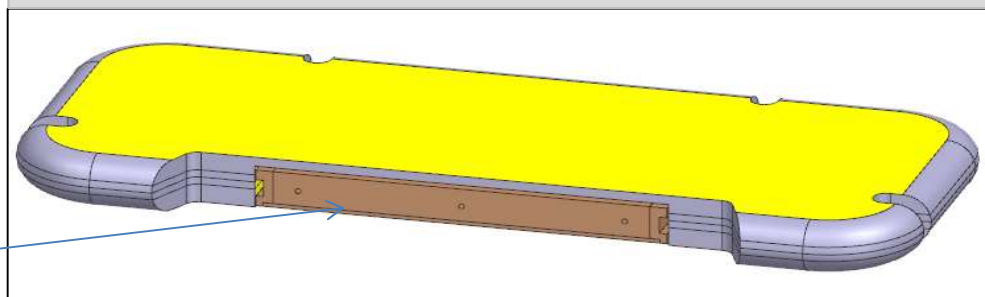

L02_AAU01

FERRAMENTA:

N° 2 - CALAMITE PER CASSETTI
N° 2 - GUIDE ACCURRIDE 250
codice 322683
BUSSOLA ZAMA

AZ26M

DA MAT 12

REV. GR 9

| LOCALE | CODICE | DESCRIZIONE COMPONENTE | FINITURA | Q.TA | OPERATORE |
|-----------------|-----------------|------------------------|------------------------|------|-----------|
| CABINA ARMATORE | AZ26M-L02_AAU01 | SCRIVANIA VANITY | LACCATO NCS S3020-Y30R | 5 | Damiano |

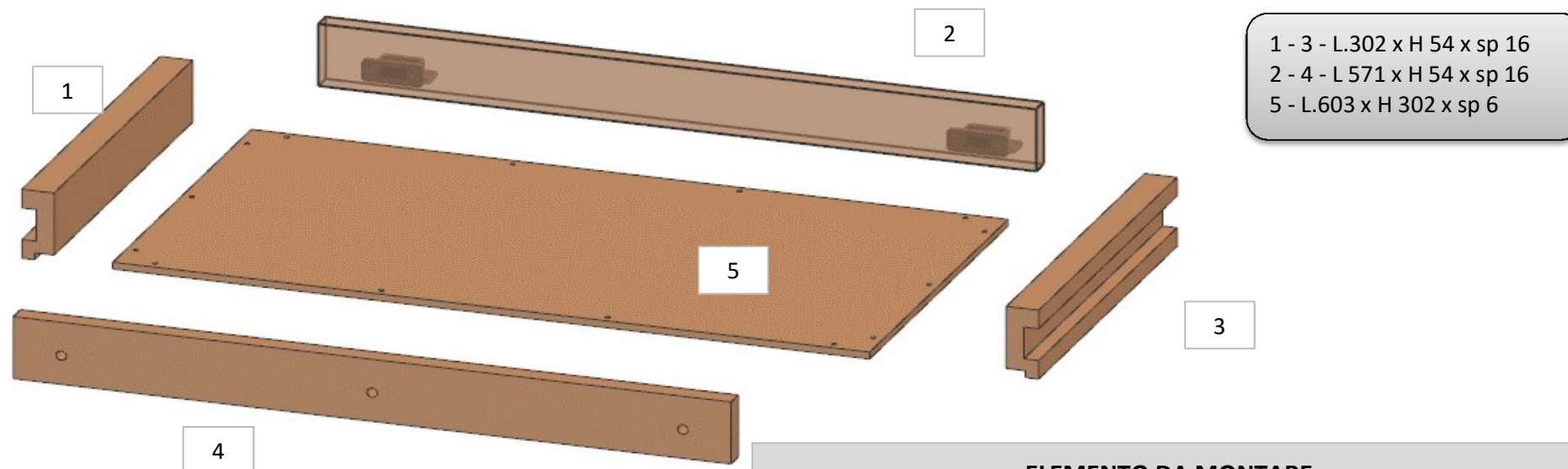

1 - 3 - L.302 x H 54 x sp 16
 2 - 4 - L 571 x H 54 x sp 16
 5 - L.603 x H 302 x sp 6

ELEMENTO DA MONTARE:
L01_AAU01
 e spedire con un unico imballo

ALLARGATO FRESATE PER LE GUIDE
 - AGGIUNTO FORI AL FONDO DEL
 CASSETTO

L01_AAU01

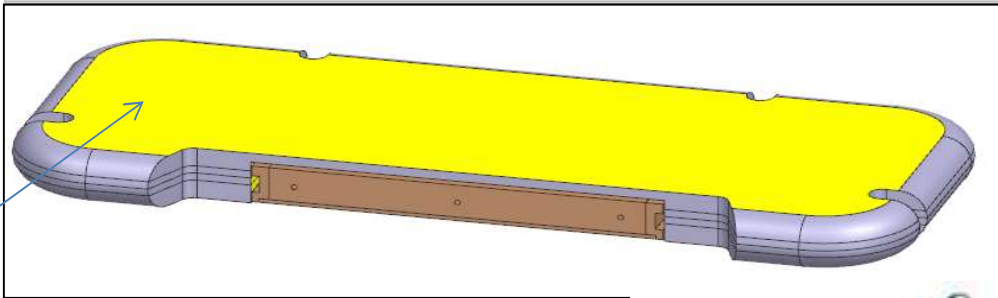

AZ26M

DA MAT 12

REV. GR 9

| LOCALE | CODICE | DESCRIZIONE COMPONENTE | FINITURA | Q.TA | OPERATORE |
|-----------------|-----------------|------------------------|----------|------|-----------|
| CABINA ARMATORE | AZ26M-A01_AAU01 | SCRIVANIA VANITY | ACCIAIO | 11 | Damiano |

MODIFICATO FORATURA PZ. 3 AGGIUNTO
PLACCHETTE SUL PIANO E AGGIUNTO PZ. 8 -
9- 10 -11

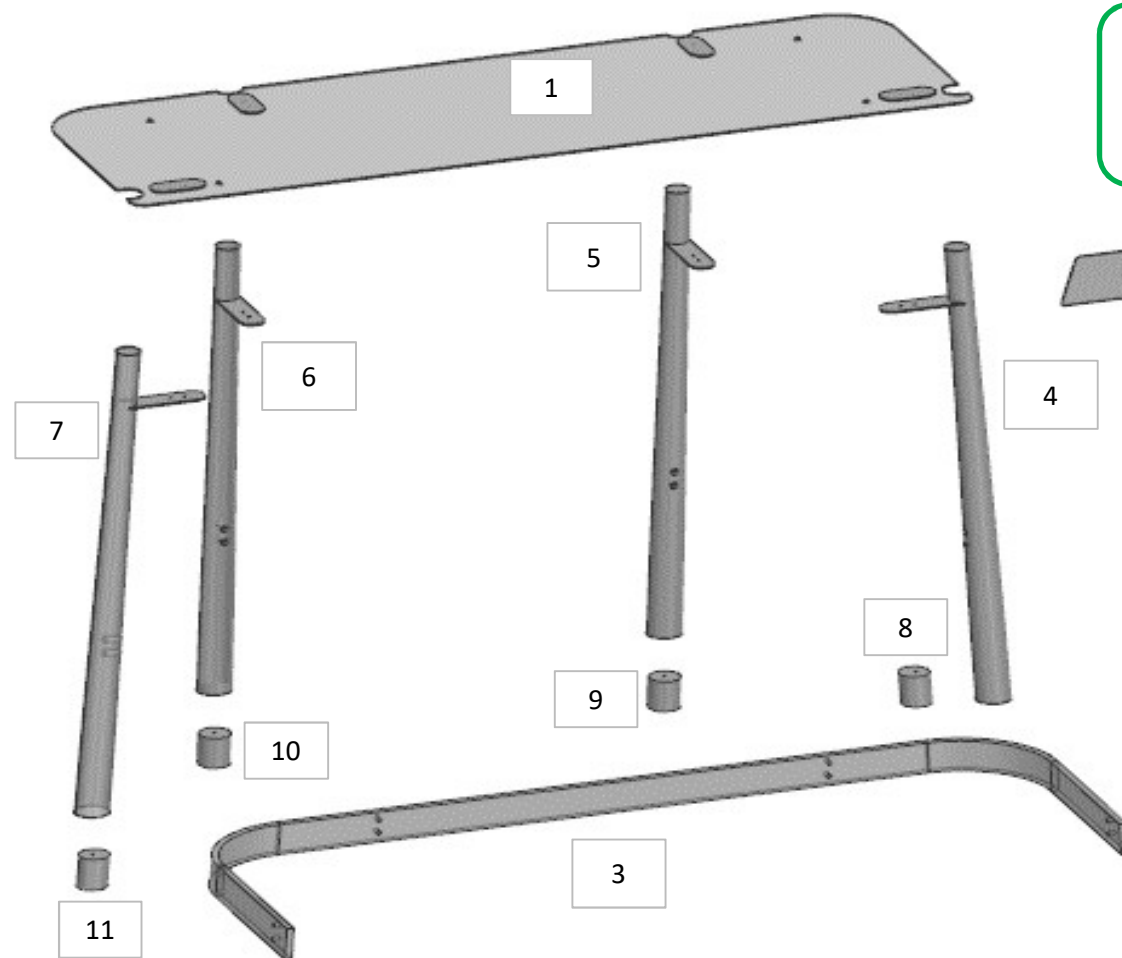

ELEMENTO DA MONTARE:
MF_AAU02
e spedire con un unico imballo

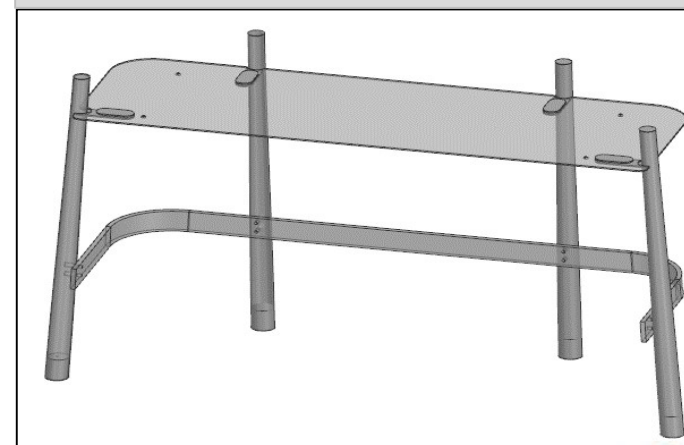

consonni&c

AZ26M

REV. GR 9

| LOCALE | CODICE | DESCRIZIONE COMPONENTE | FINITURA | Q.TA | OPERATORE |
|----------------|---------------|---------------------------|----------|------|-----------|
| BAGNO ARMATORE | AZ26M-MG_WD01 | PARETE MISCELATORI DOCCIA | | | Damiano |

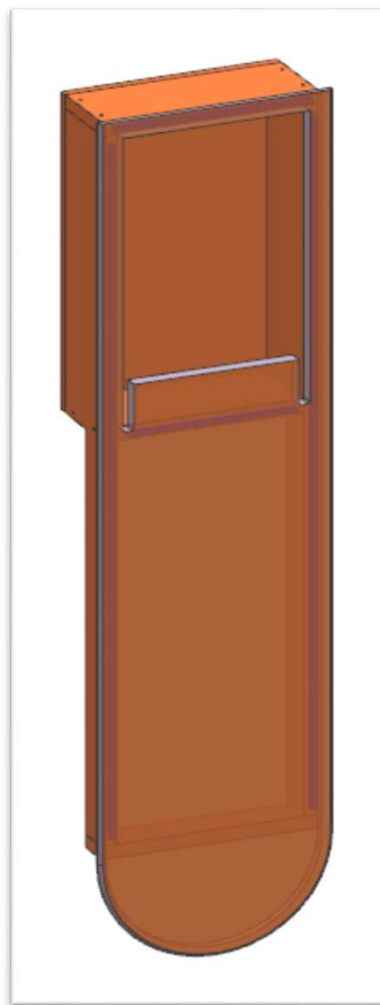

AZ26M

REV. GR 9

| LOCALE | CODICE | DESCRIZIONE COMPONENTE | FINITURA | Q.TA | OPERATORE |
|----------------|----------------|---------------------------|----------------|------|-----------|
| BAGNO ARMATORE | AZ26M-L02_WD01 | PARETE MISCELATORI DOCCIA | LACCATO BRONZO | 7 | Damiano |

2 - 4 - L 90 x H.852 x SP 16
 3 - L.90 x H 236 x SP 16
 5 - L.90 x H 204 x SP 16
 6 - L.236 x H 380 x SP 10
 7 - L.40 x H 236 x SP 16

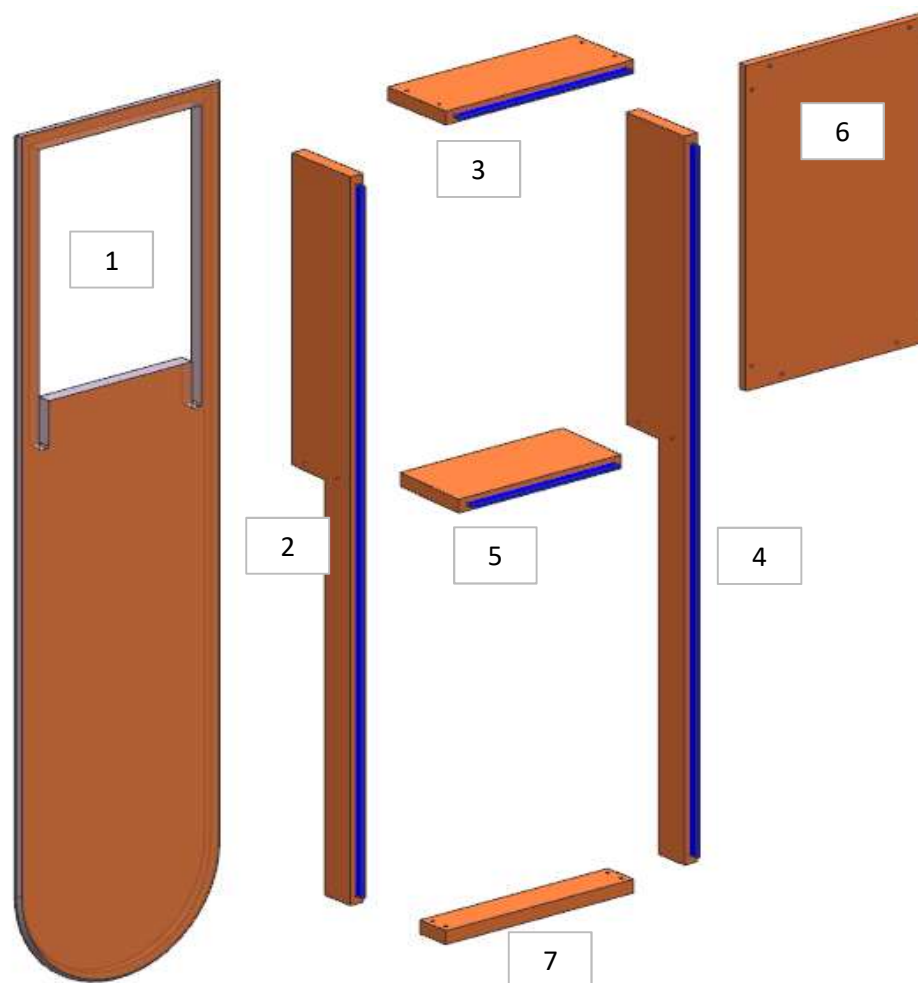

**ELEMENTO DA MONTARE:
 MG_WD01
 e spedire con un
 unico imballo**

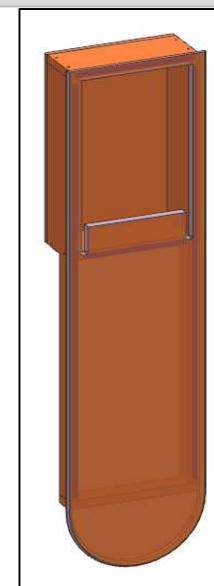

AZ26M

REV. GR 9

| LOCALE | CODICE | DESCRIZIONE COMPONENTE | FINITURA | Q.TA | OPERATORE |
|----------------|----------------|------------------------|-------------------------|------|-----------|
| BAGNO ARMATORE | AZ26M-L01_WG01 | PARETE NICCHIA WATER | LACCATO BIANCO RAL 9010 | 10 | Damiano |

1 - L 454 x H.573 x SP 19
 2 - L 458 x H.847 x SP 16
 3 - L 110 x H.1840 x SP 19



1

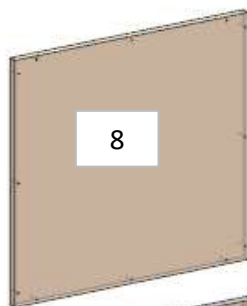

8

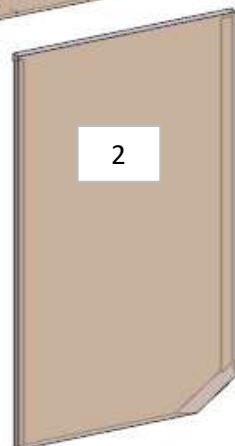

2

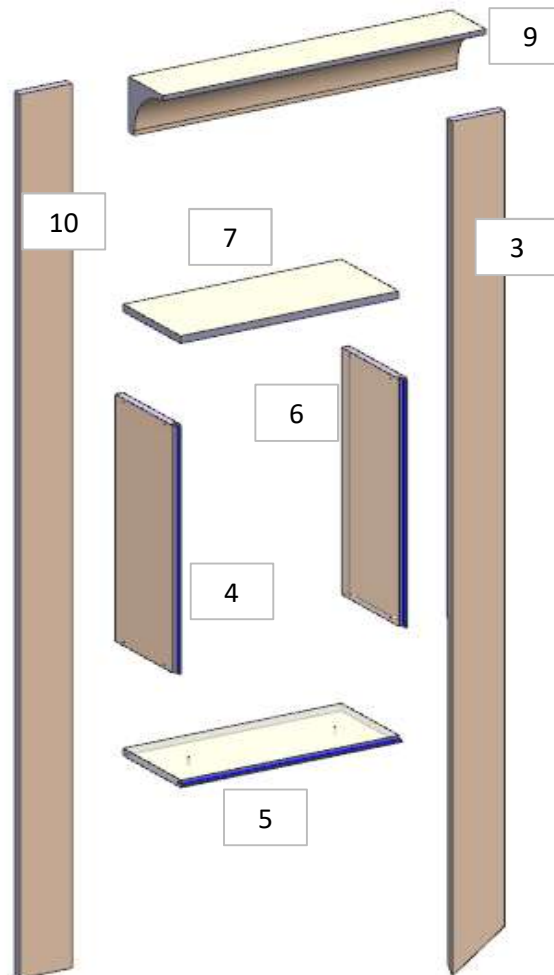

10

7

3

4

6

5

9

4 - 6 - L 199 x H.532 x SP 16
 5 - 7- L 199 x H.458 x SP 16
 8 - L 492 x H.532 x SP 16
 9 - L 679 x H.120 x 119
 10 - L 110 x H 1904 x SP 19

ELEMENTO DA MONTARE:
X01_WG01
MG_WG02
 e spedire con un unico

X01_WG01

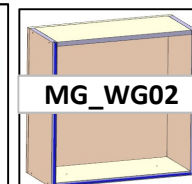
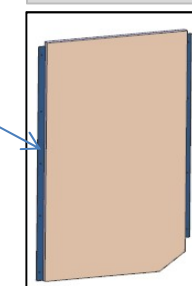

MG_WG02

AZ26M

REV. GR 9

| LOCALE | CODICE | DESCRIZIONE COMPONENTE | FINITURA | Q.TA | OPERATORE |
|----------------|----------------|------------------------|---------------|------|-----------|
| BAGNO ARMATORE | AZ26M-R01_WM01 | SEDUTA DOCCIA | LASTRA CHIARA | 1 | Damiano |

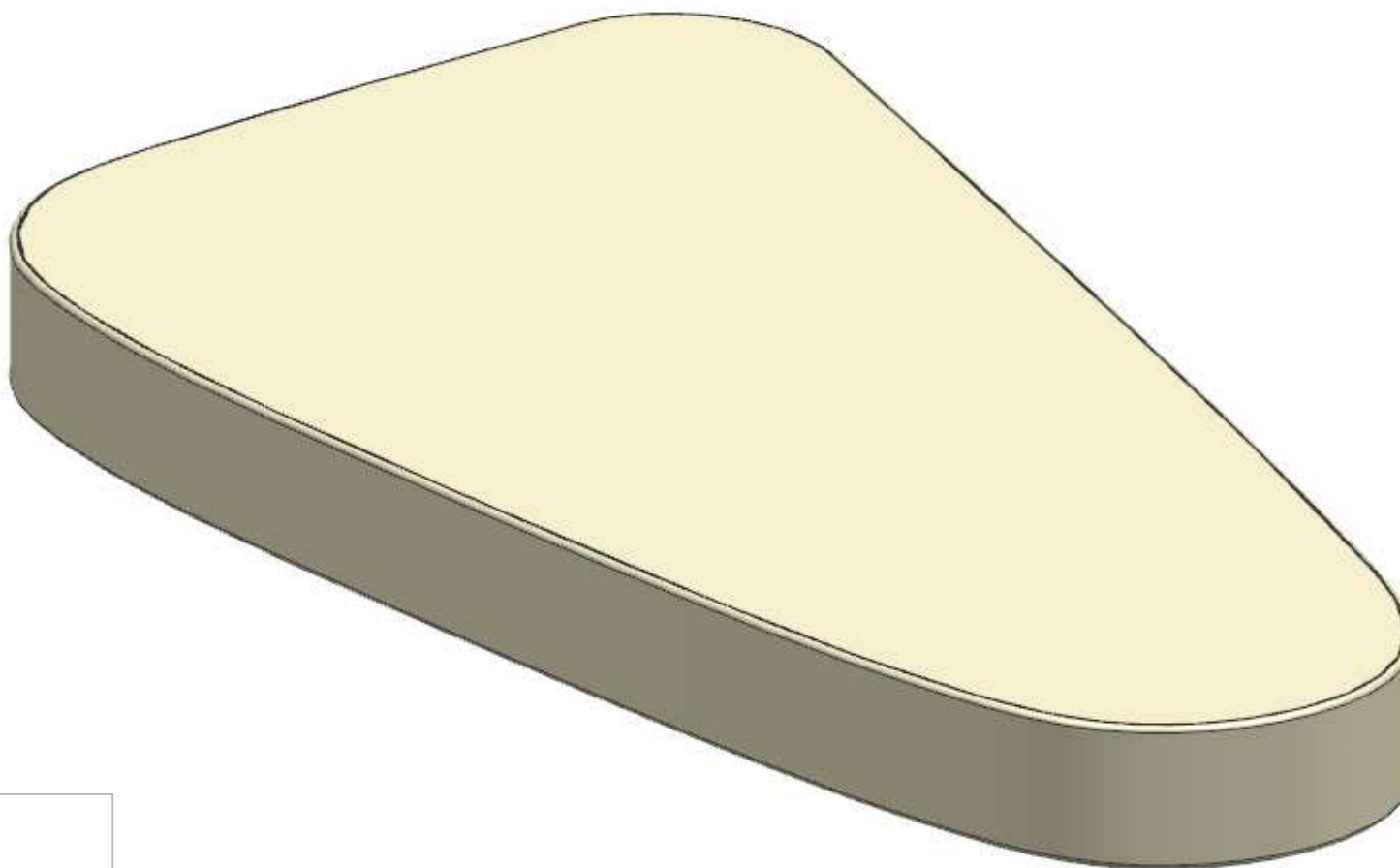

FERRAMENTA:

N° 14 - SPINA diam 8

AZ26M

REV. GR 9

| LOCALE | CODICE | DESCRIZIONE COMPONENTE | FINITURA | Q.TA | OPERATORE |
|----------------|----------------|------------------------|----------|------|-----------|
| BAGNO ARMATORE | AZ26M-A01_WM01 | SEDUTA DOCCIA | ACCIAIO | 1 | Damiano |



consonni&c

AZ26M

REV. GR 9

| LOCALE | CODICE | DESCRIZIONE COMPONENTE | FINITURA | Q.TA | OPERATORE |
|----------------|----------------|------------------------|-------------|------|-----------|
| BAGNO ARMATORE | AZ26M-R01_WN01 | CARABOTTINO | LASTRA TEAK | 3 | Damiano |

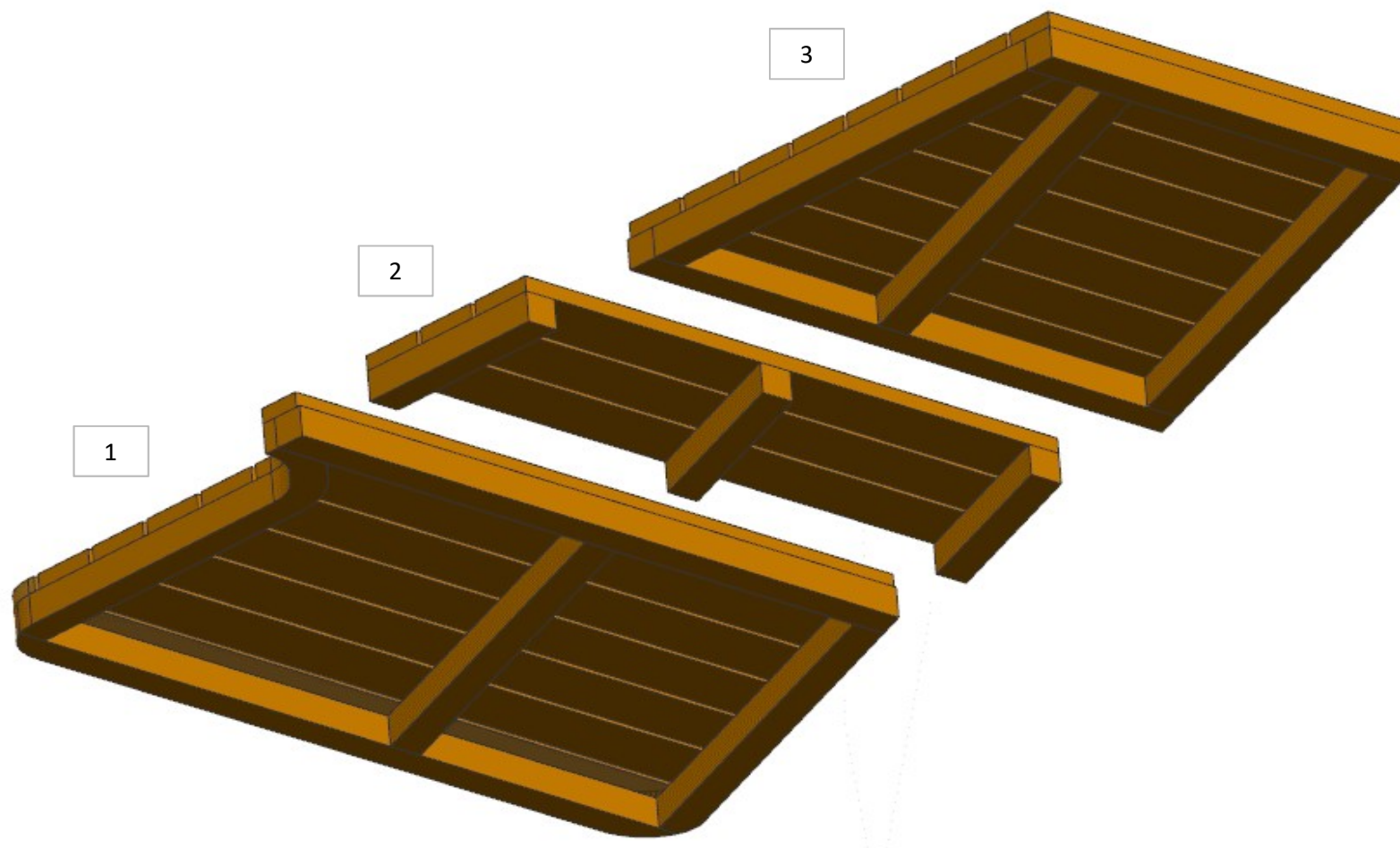

AZ26M

MOD DA PTP

REV. GR 9

| LOCALE | CODICE | DESCRIZIONE COMPONENTE | FINITURA | Q.TA | OPERATORE |
|----------------|----------------|------------------------|-------------------------|------|-----------|
| BAGNO ARMATORE | AZ26M-L01_WQ01 | CIELINO ZONA LAVELLO | LACCATO BIANCO RAL 9016 | 2 | Damiano |

MOD N.146
AGGIUNTI FORI FARETTI

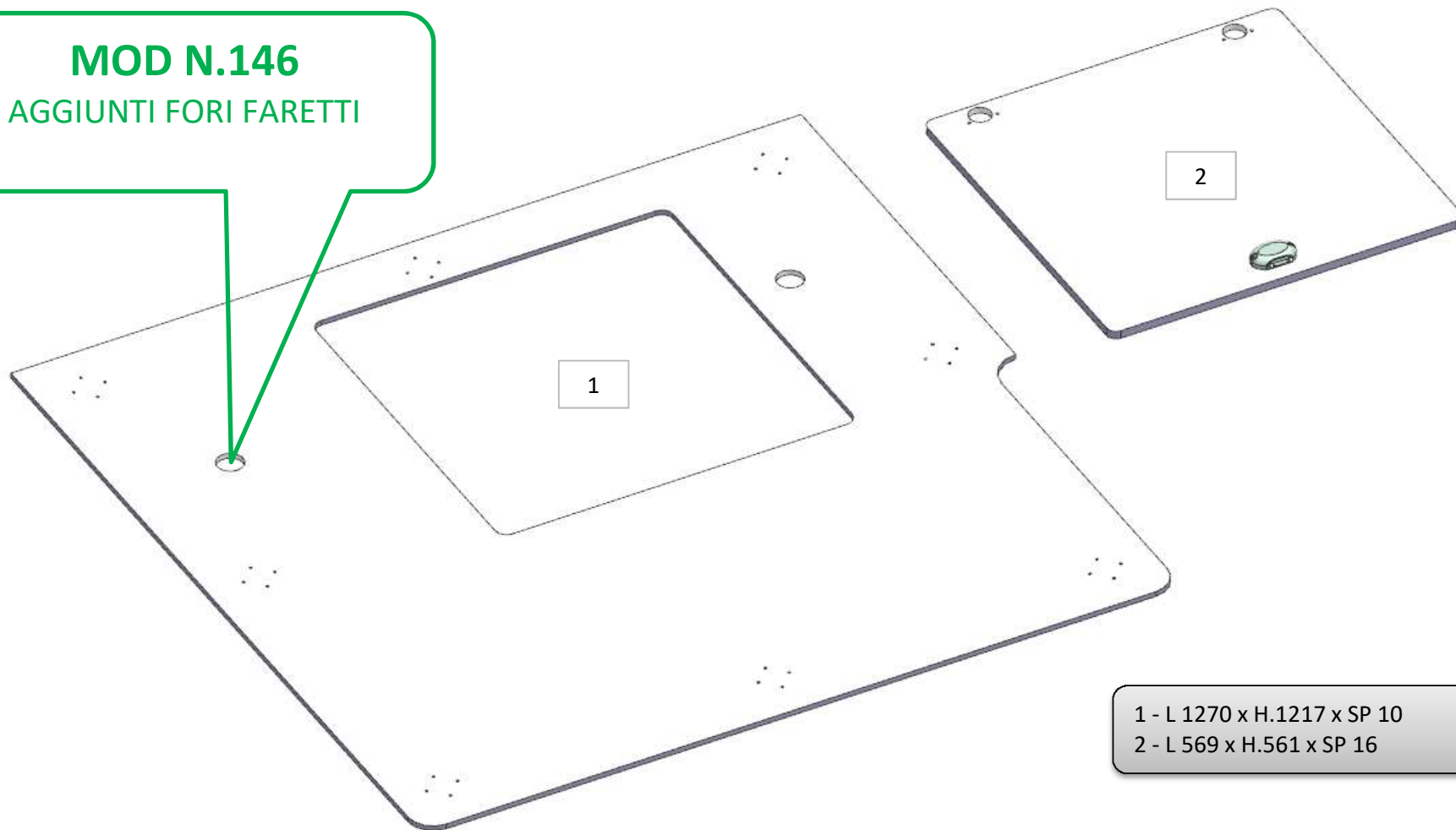

- 1 - L 1270 x H.1217 x SP 10
- 2 - L 569 x H.561 x SP 16

AZ26M

DA GR.2

REV. GR 9

| LOCALE | CODICE | DESCRIZIONE COMPONENTE | FINITURA | Q.TA | OPERATORE |
|----------------|----------------|------------------------|-------------------------|------|-----------|
| BAGNO ARMATORE | AZ26M-L01_WO01 | CIELINO DOCCIA | LACCATO BIANCO RAL 9016 | 1 | Damiano |

1 - L 1130 x H.1120 x SP 10

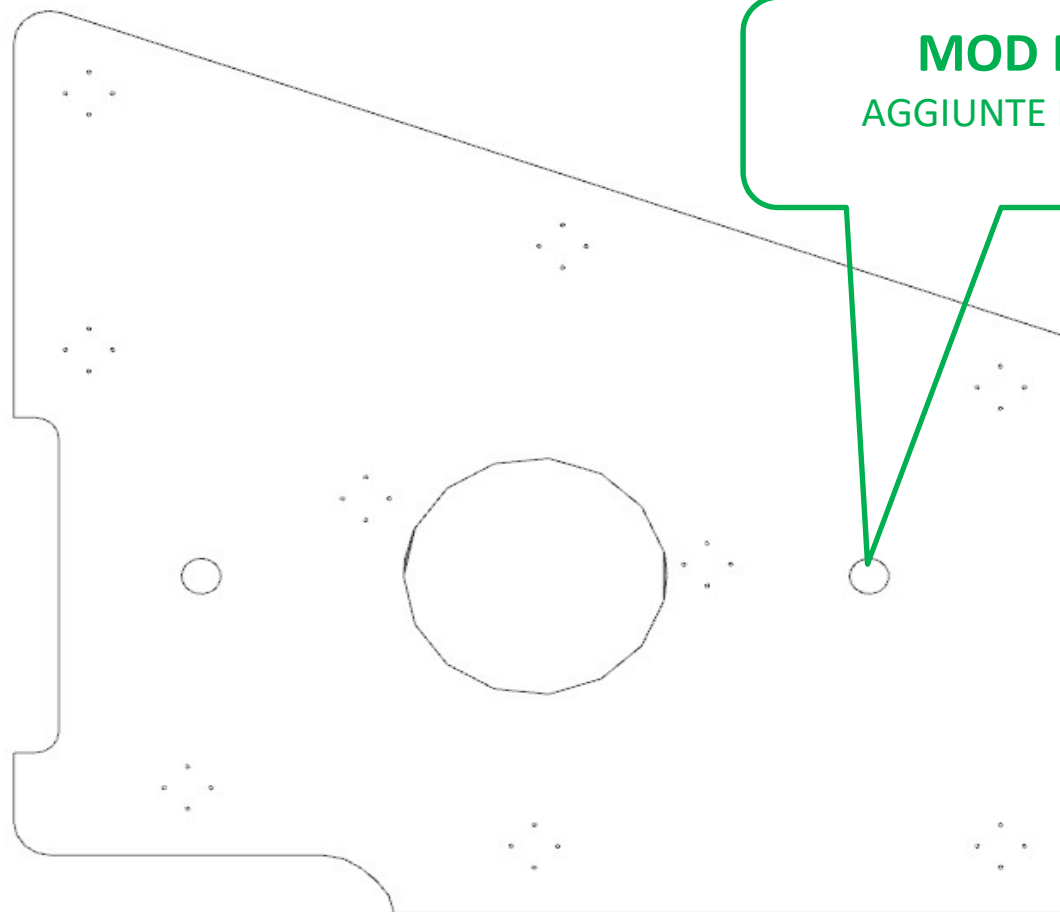

AZ26M

DA GR.2

REV. GR 9

| LOCALE | CODICE | DESCRIZIONE COMPONENTE | FINITURA | Q.TA | OPERATORE |
|----------------|----------------|------------------------|-------------------------|------|-----------|
| BAGNO ARMATORE | AZ26M-L01_WP01 | CIELINO WC STD-VAR 1 | LACCATO BIANCO RAL 9010 | 1 | Damiano |

1 - L 941 x H.679 x SP 11

MOD N.150
AGGIUNTE FORATURE

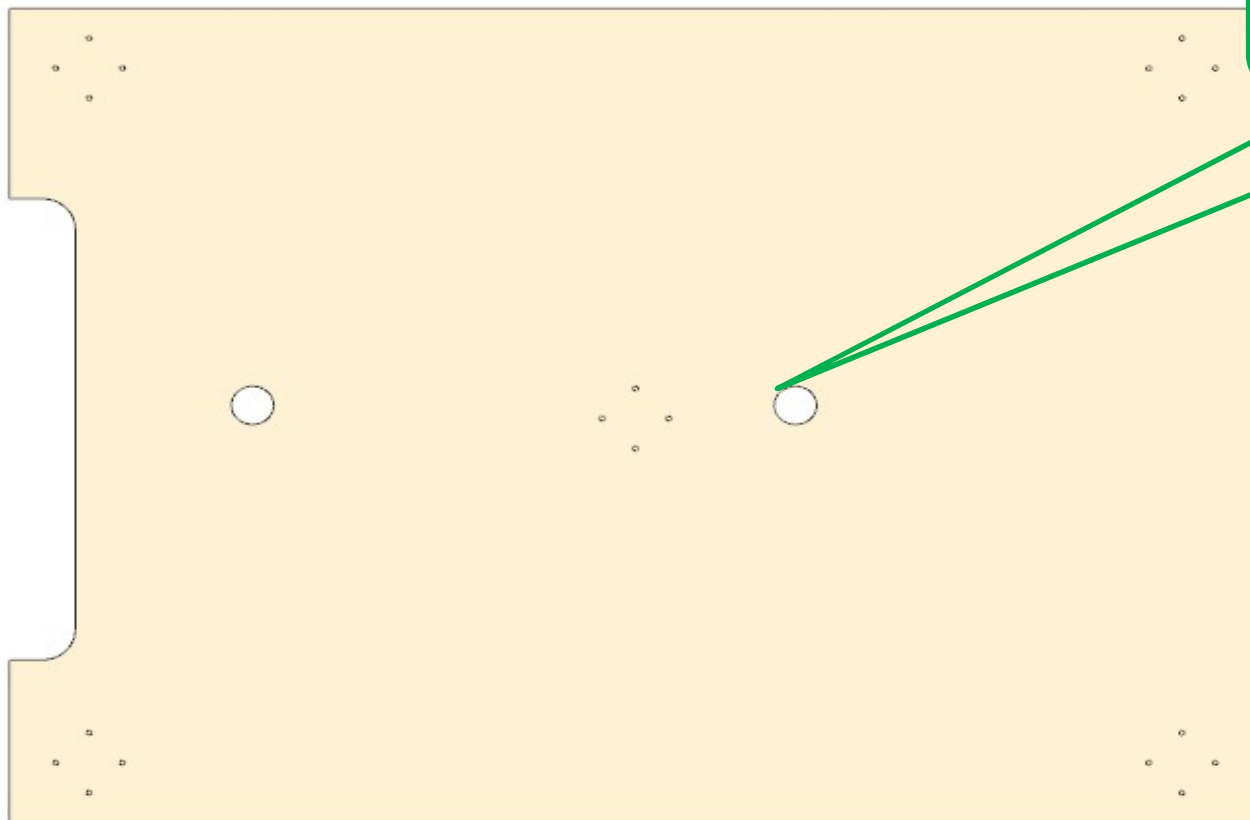

AZ26M

REV. GR 9

| LOCALE | CODICE | DESCRIZIONE COMPONENTE | FINITURA | Q.TA | OPERATORE |
|----------------|----------------|-----------------------------------|--------------|------|-----------|
| BAGNO ARMATORE | AZ26M-R01_WS01 | PAVIMENTO BAGNO STD-VAR 1 s-bidet | IROKO DOGATO | 6 | Daminao |

- 1 - L 468 x H.970 x SP 16
- 2 - L 436 x H.1278 x SP 16
- 3 - L 356 x H.2167 x SP 16
- 4 - L 392 x H.2051 x SP 16
- 5 - L 356 x H.1080 x SP 16
- 6 - L 418 x H.1080 x SP 16

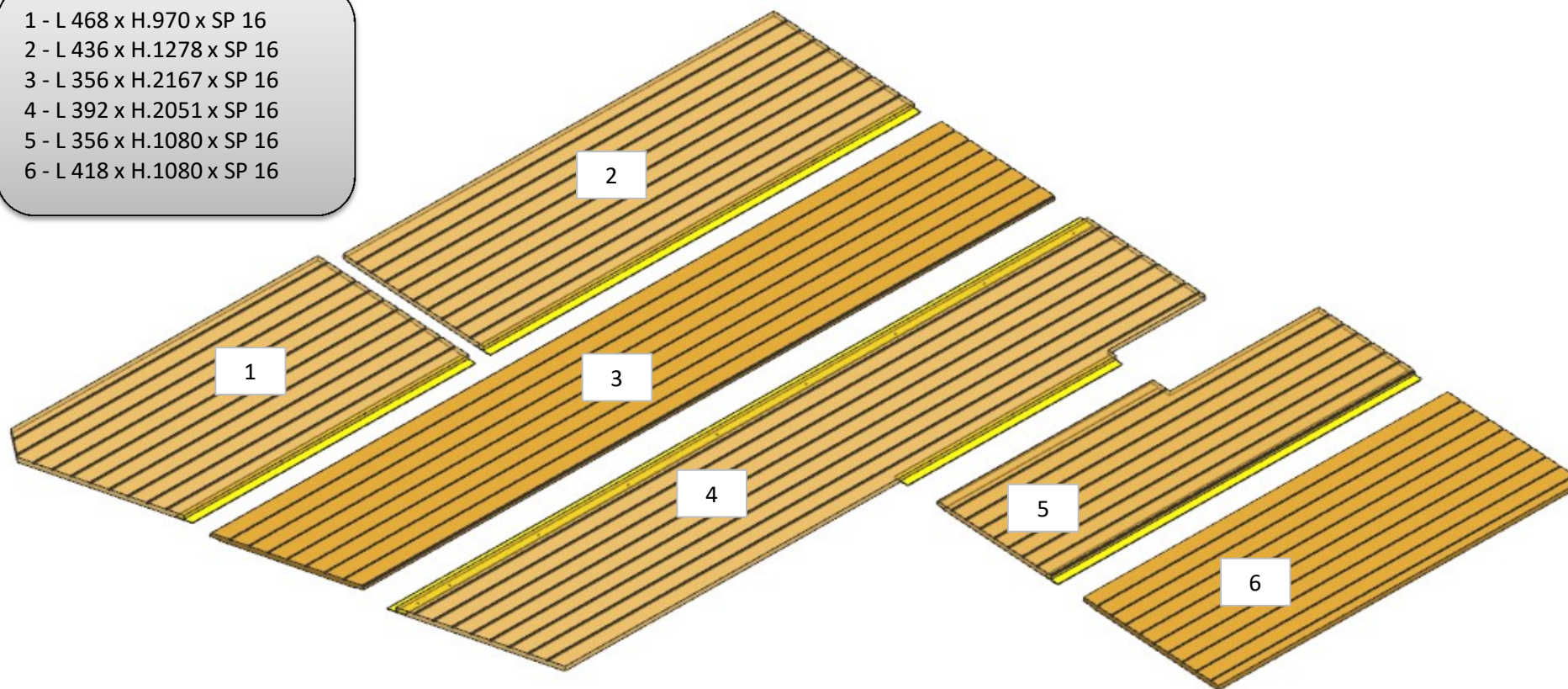

AZ26M

REV. GR 9

| LOCALE | CODICE | DESCRIZIONE COMPONENTE | FINITURA | Q.TA | OPERATORE |
|----------------|-----------------|------------------------|-------------------------|------|-----------|
| BAGNO ARMATORE | AZ26M-L01_WWP01 | CIELINO WC STD-VAR 2 | LACCATO BIANCO RAL 9010 | 1 | Damiano |

1 - 1339 x H.679 x SP 11

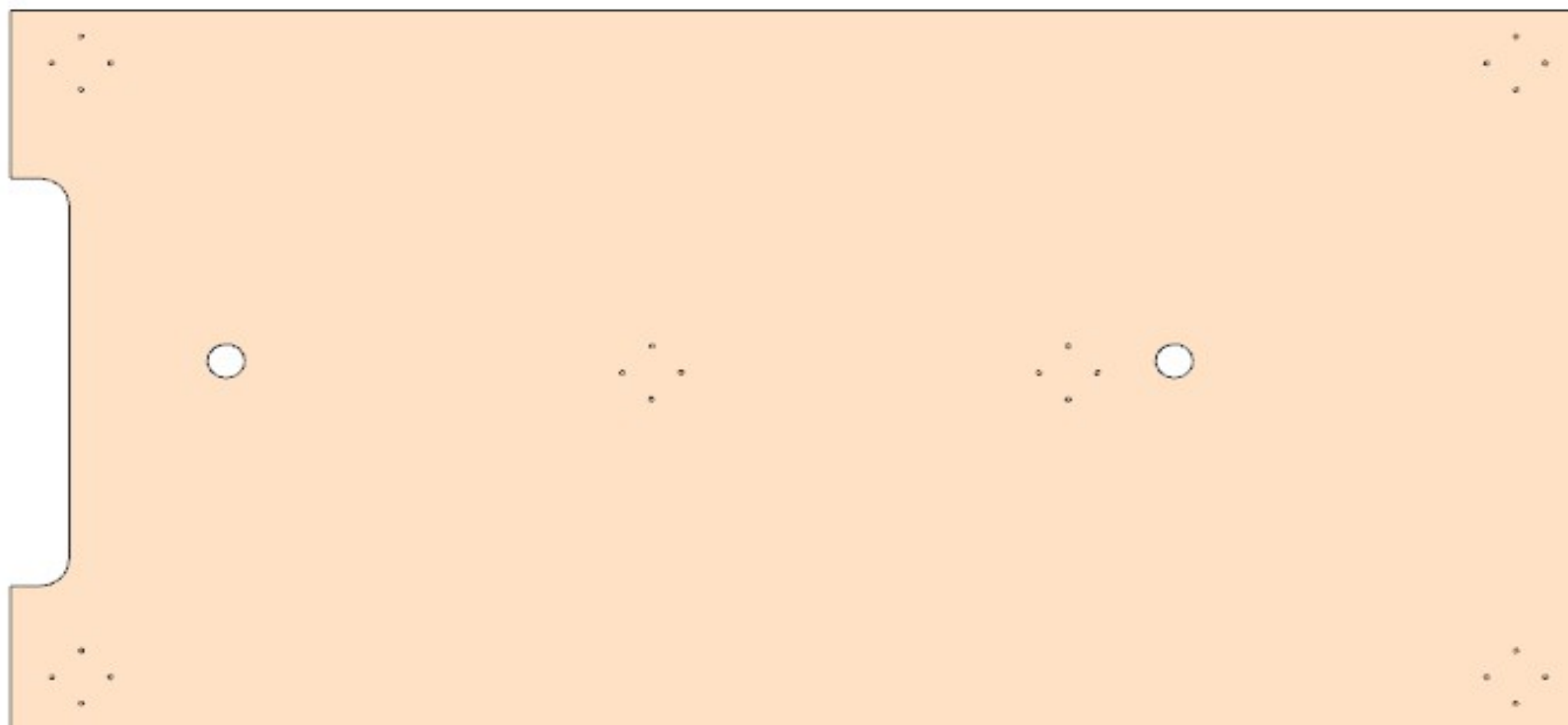

AZ26M

REV. GR 9

| LOCALE | CODICE | DESCRIZIONE COMPONENTE | FINITURA | Q.TA | OPERATORE |
|----------------|-----------------|-------------------------------------|--------------|------|-----------|
| BAGNO ARMATORE | AZ26M-R01_WWS01 | PAVIMENTO BAGNO STD-VAR 2 con Bidet | IROKO DOGATO | 6 | Daminao |

- 1 - L 468 x H.970 x SP 16
- 2 - L 436 x H.1278 x SP 16
- 3 - L 356 x H.2167 x SP 16
- 4 - L 392 x H.2051 x SP 16
- 5 - L 356 x H.1479 x SP 16
- 6 - L 418 x H.1479 x SP 16

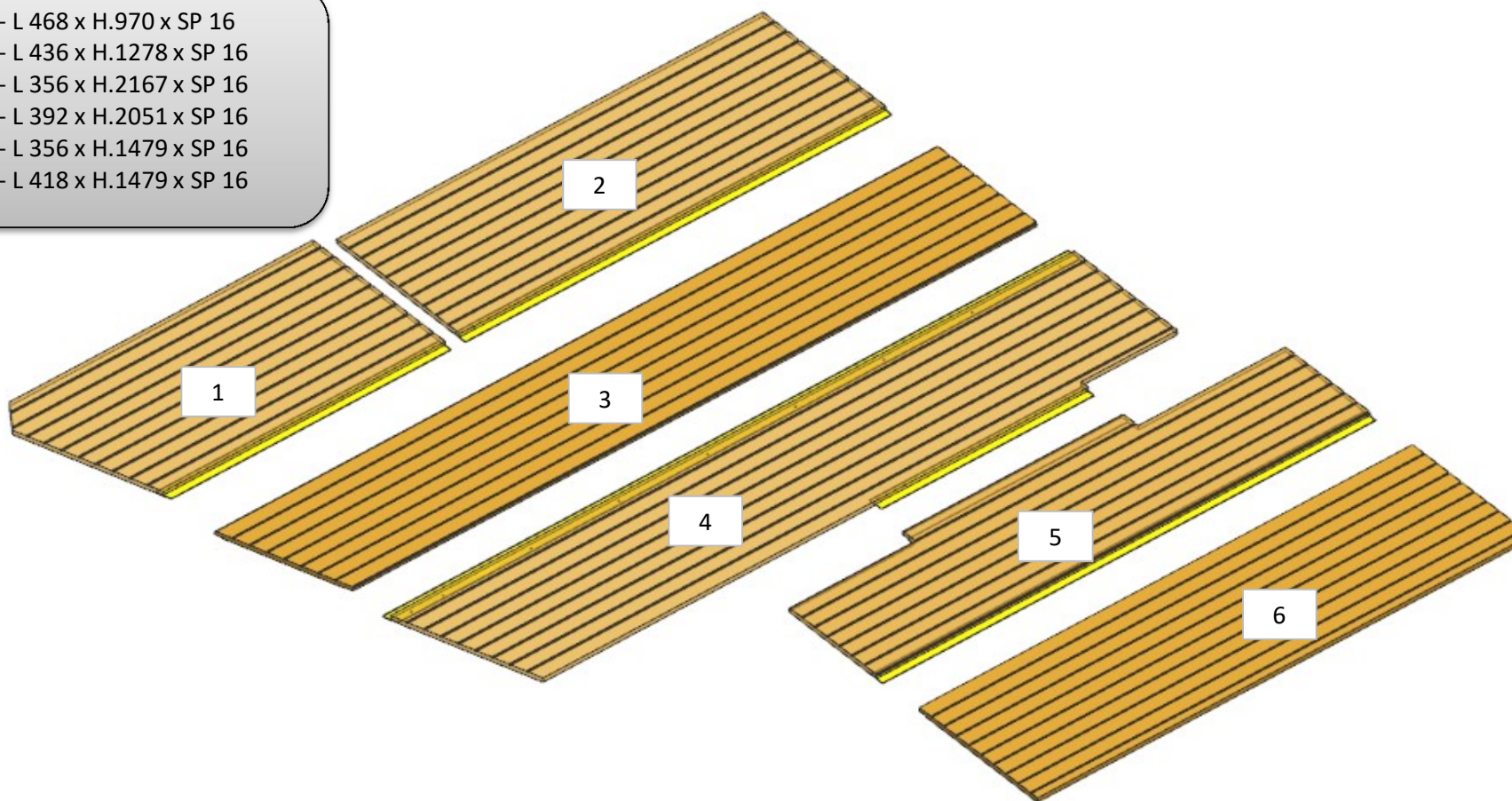

AZ26M

MOD DA GR9

REV. GR 9

| LOCALE | CODICE | DESCRIZIONE COMPONENTE | FINITURA | Q.TA | OPERATORE |
|--------|----------------|------------------------|---------------|------|-----------|
| CUCINA | AZ26M-R01_KA01 | CASSA FRIGO POPPA | LASTRA CHIARA | 10 | Damiano |

- 1 - L 147 x H.2026 x 105
- 2 - L 150 x H.1058 x sp 25
- 3 - L 152 x H.70 x sp 16
- 4 - L 150 x H.717 x sp 25
- 5 - L 1082 x H.106 x sp 25
- 6 - L 48 x H.2026 x sp 56
- 7 - L 314 x H.1147 x sp 11
- 8 - L 46 x H.879 x sp 11
- 9 - L 150 x H.1810 x sp 16
- 10 - L 150 x H.930 x sp 16

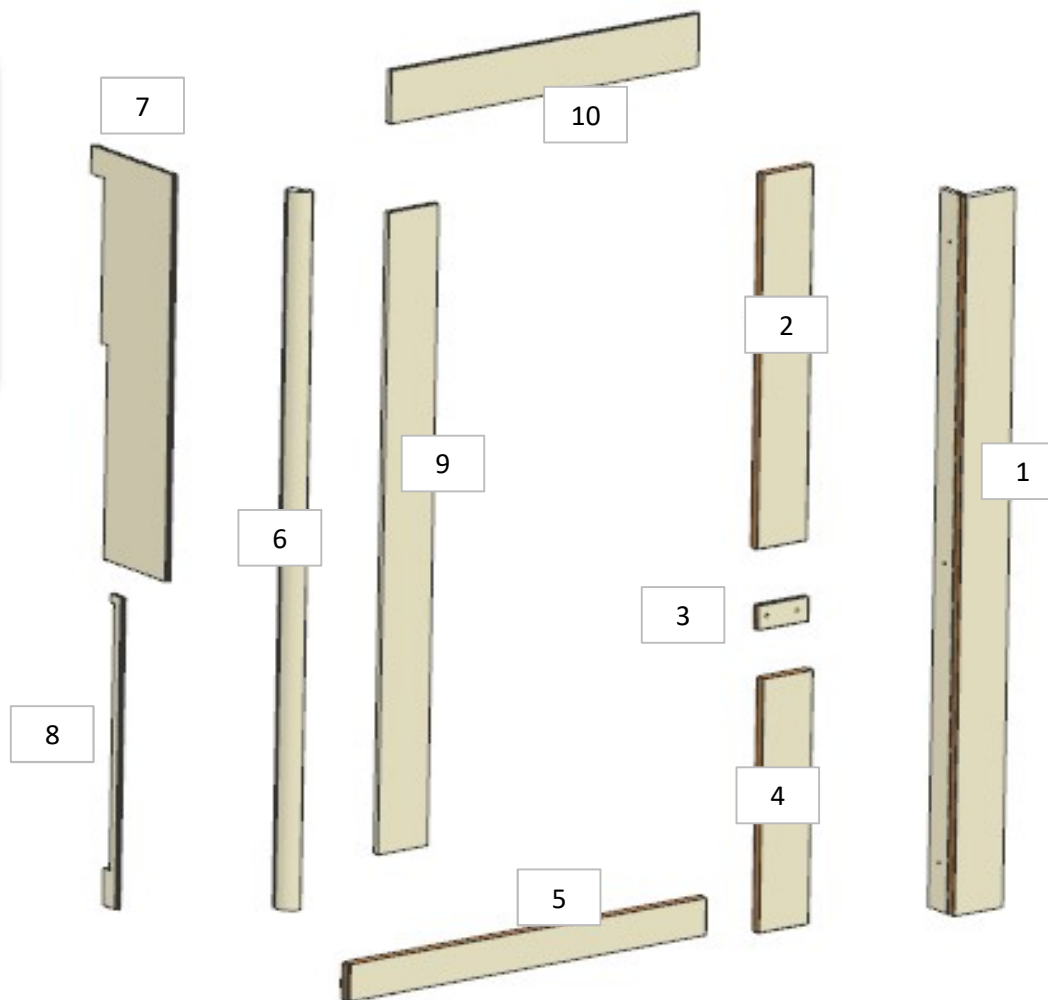

MOD AZ 260
AGGIUNTE FASCE
TAMPONAMENTO
FRIGO AGGIUNTO
PEZZO 9 E 10

AZ26M

REV. 01-2023

REV. GR 9

| LOCALE | CODICE | DESCRIZIONE COMPONENTE | FINITURA | Q.TA | OPERATORE |
|--------|----------------|----------------------------------|---------------|------|-----------|
| CUCINA | AZ26M-R01_KB01 | CASSA RICIRCOLO ARIA FRIGO POPPA | LASTRA CHIARA | 1 | Damiano |

1 - L 1082 x H.111 x sp 25

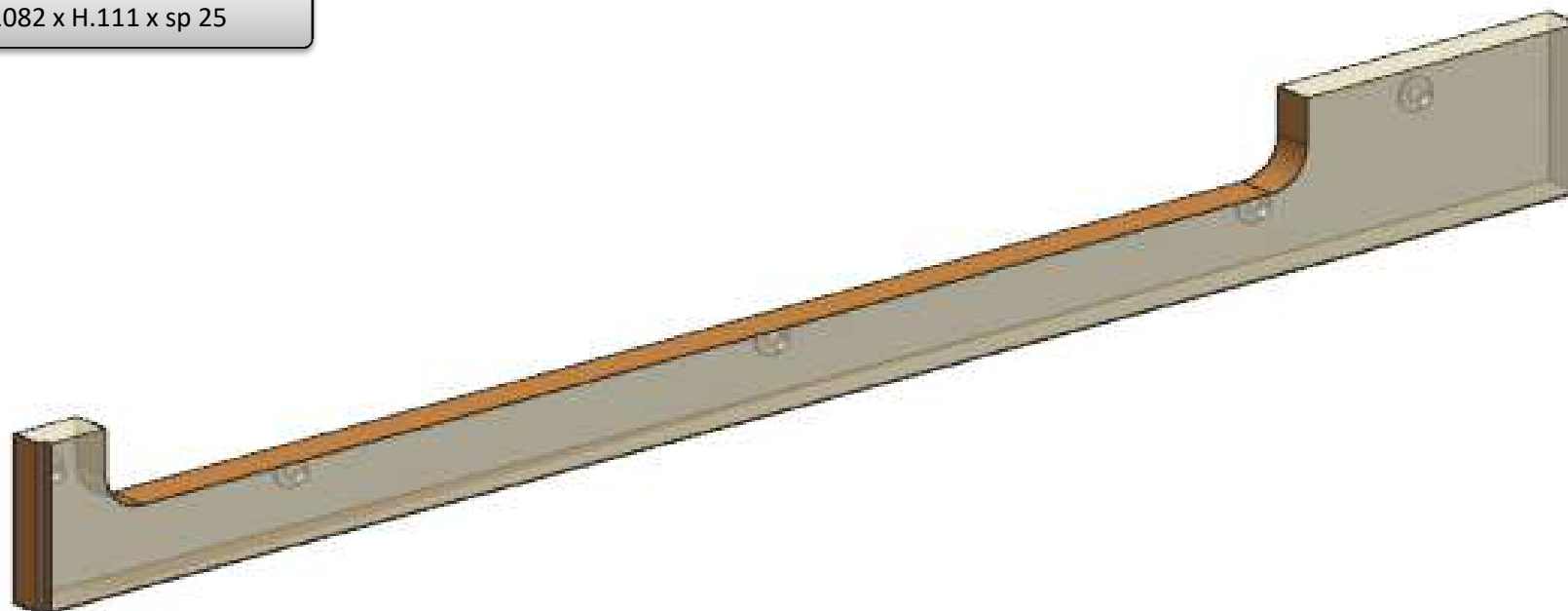

AZ26M

REV. 01-2023

REV. GR 10

| LOCALE | CODICE | DESCRIZIONE COMPONENTE | FINITURA | Q.TA | OPERATORE |
|--------|----------------|----------------------------------|----------------|------|-----------|
| CUCINA | AZ26M-L01_KB01 | CASSA RICIRCOLO ARIA FRIGO POPPA | LACCATO BRONZO | 1 | Damiano |

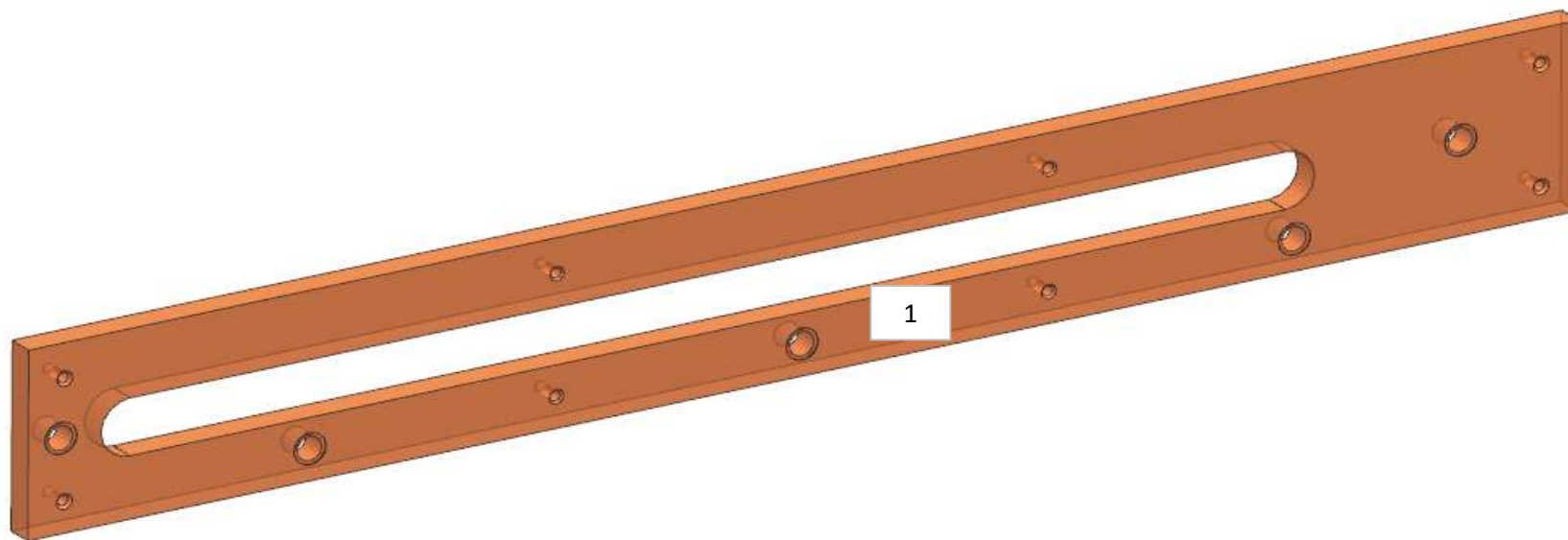

AZ26M

REV. 01-2023

REV. GR 9

| LOCALE | CODICE | DESCRIZIONE COMPONENTE | FINITURA | Q.TA | OPERATORE |
|--------|----------------|------------------------|---------------|------|-----------|
| CUCINA | AZ26M-R01_KC01 | BASE CUCINA POPPA | LASTRA CHIARA | 1 | Damiano |

1 - L 1588 x H 105 x sp 25

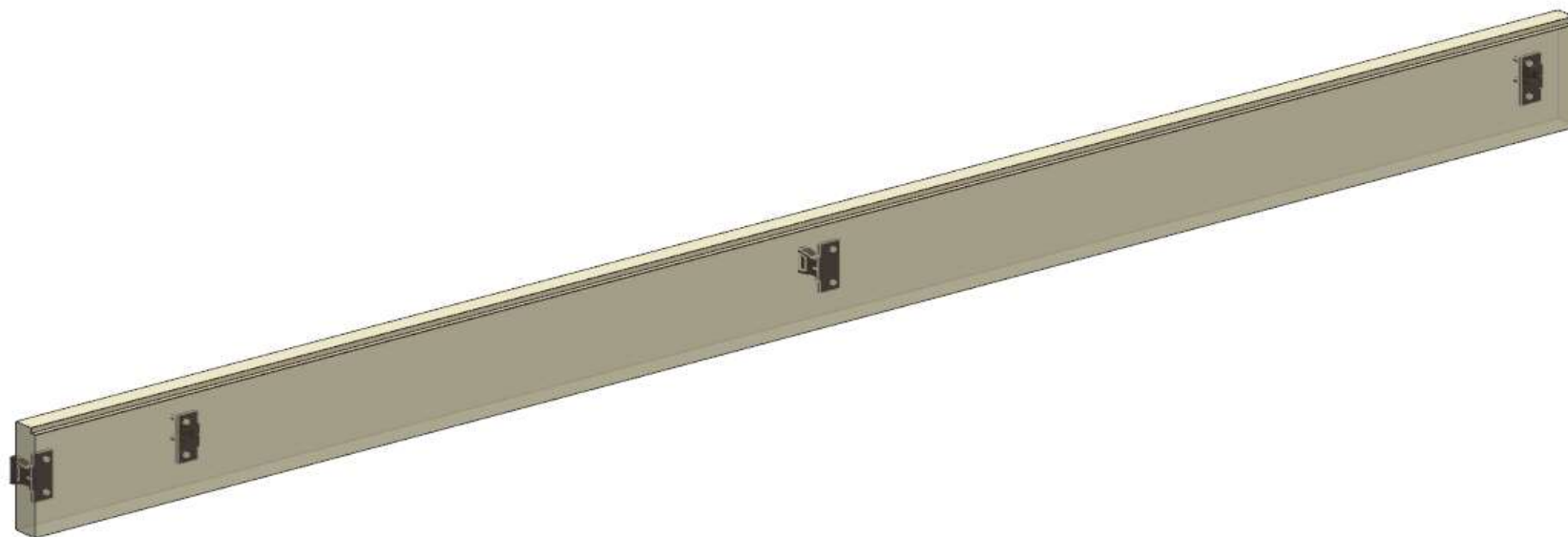

AZ26M

MOD GR5

REV. GR 9

| LOCALE | CODICE | DESCRIZIONE COMPONENTE | FINITURA | Q.TA | OPERATORE |
|--------|----------------|------------------------|-------------------------|------|-----------|
| CUCINA | AZ26M-L01_KC01 | BASE CUCINA POPPA | LACCATO BIANCO RAL 9010 | 5 | Damiano |

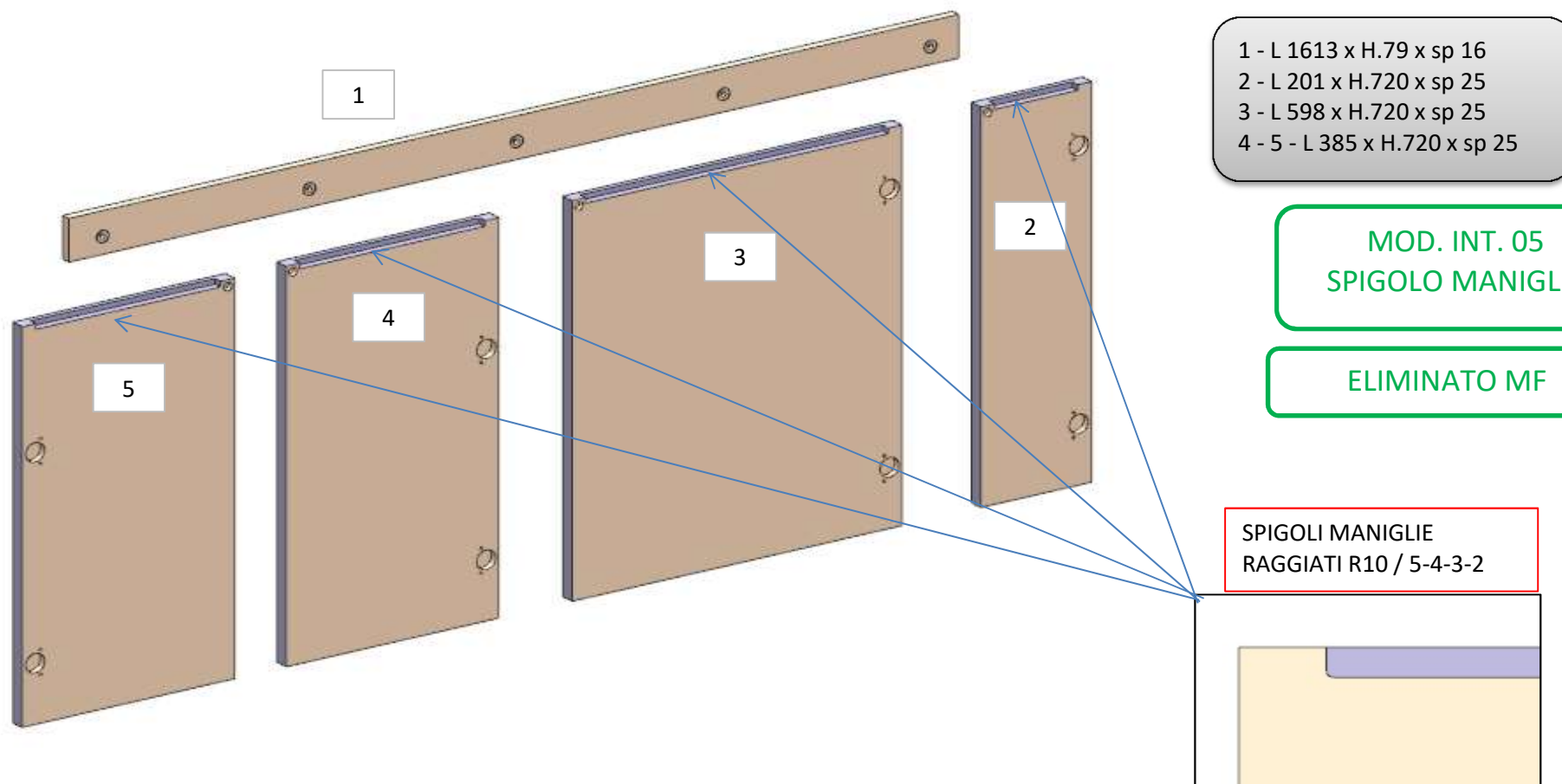

AZ26M

MOD GR5

REV. GR 9

| LOCALE | CODICE | DESCRIZIONE COMPONENTE | FINITURA | Q.TA | OPERATORE |
|--------|----------------|------------------------|-------------------------|------|-----------|
| CUCINA | AZ26M-L01_KD01 | PENSILE CUCINA POPPA | LACCATO BIANCO RAL 9010 | 6 | Damiano |

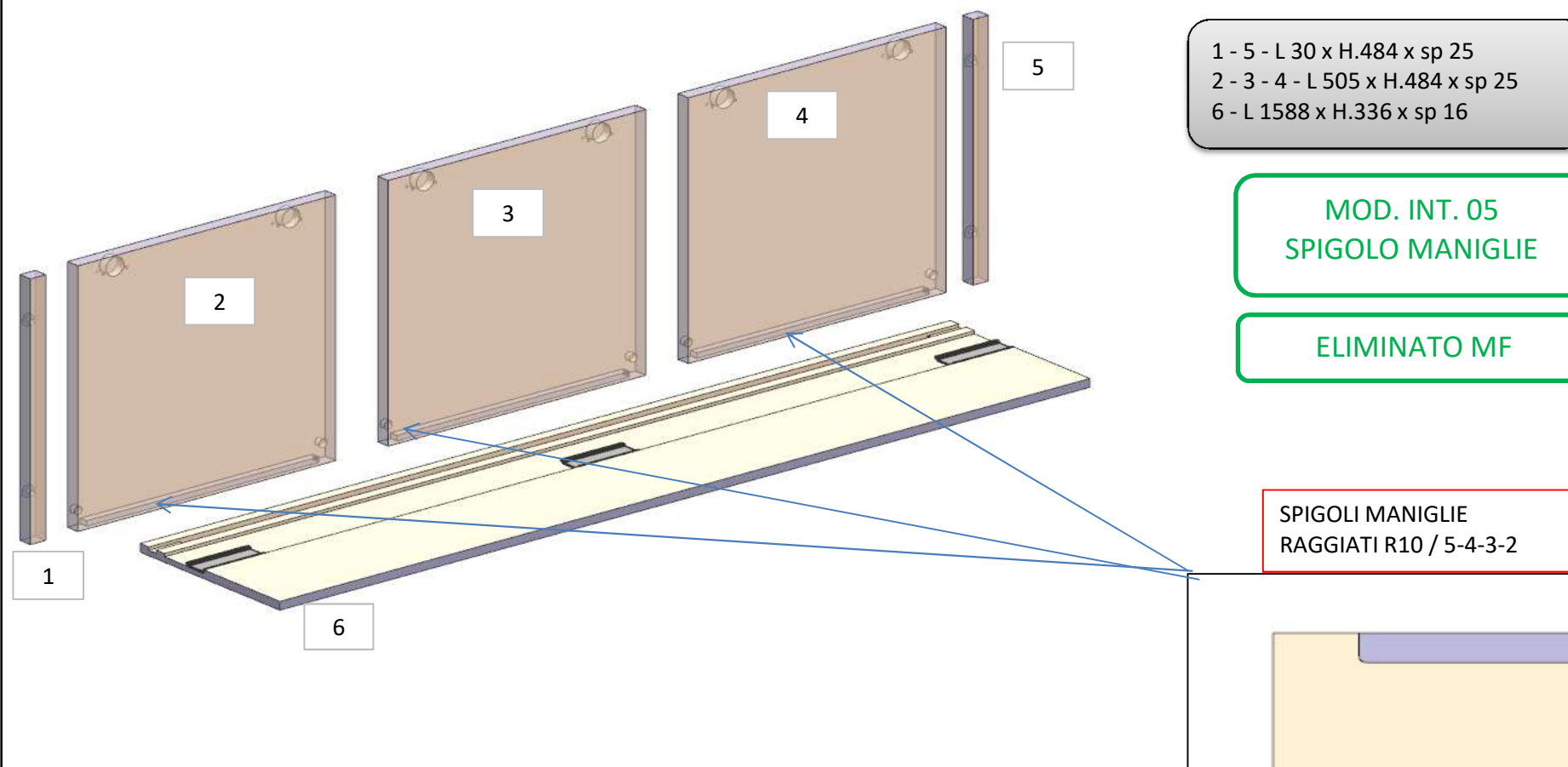

AZ26M

REV. GR 9

| LOCALE | CODICE | DESCRIZIONE COMPONENTE | FINITURA | Q.TA | OPERATORE |
|--------|----------------|------------------------|----------|------|-----------|
| CUCINA | AZ26M-X01_KE01 | RIV. MARMO POPPA | BETACRIL | 3 | Damiano |

1 - 3 - L 362 x H.595 x sp 12
2 - L 1587 x H.579 x sp 12

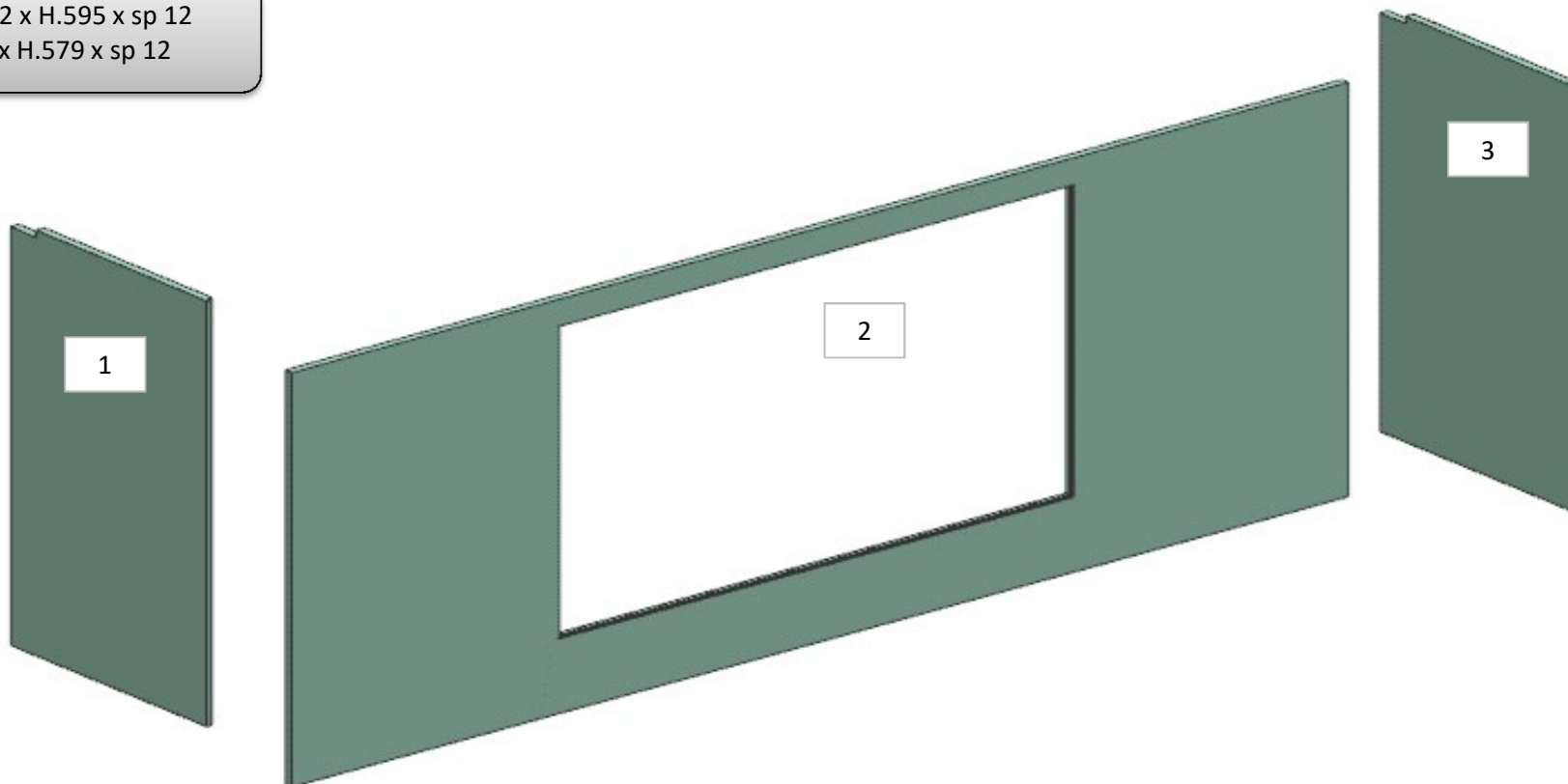

AZ26M

REV. 01-2023

REV. GR 9

| LOCALE | CODICE | DESCRIZIONE COMPONENTE | FINITURA | Q.TA | OPERATORE |
|--------|----------------|------------------------|---------------|------|-----------|
| CUCINA | AZ26M-R01_KF01 | BASE CUCINA PRUA | LASTRA CHIARA | 1 | Damiano |

1 - L 1293 x H 105 x sp 16

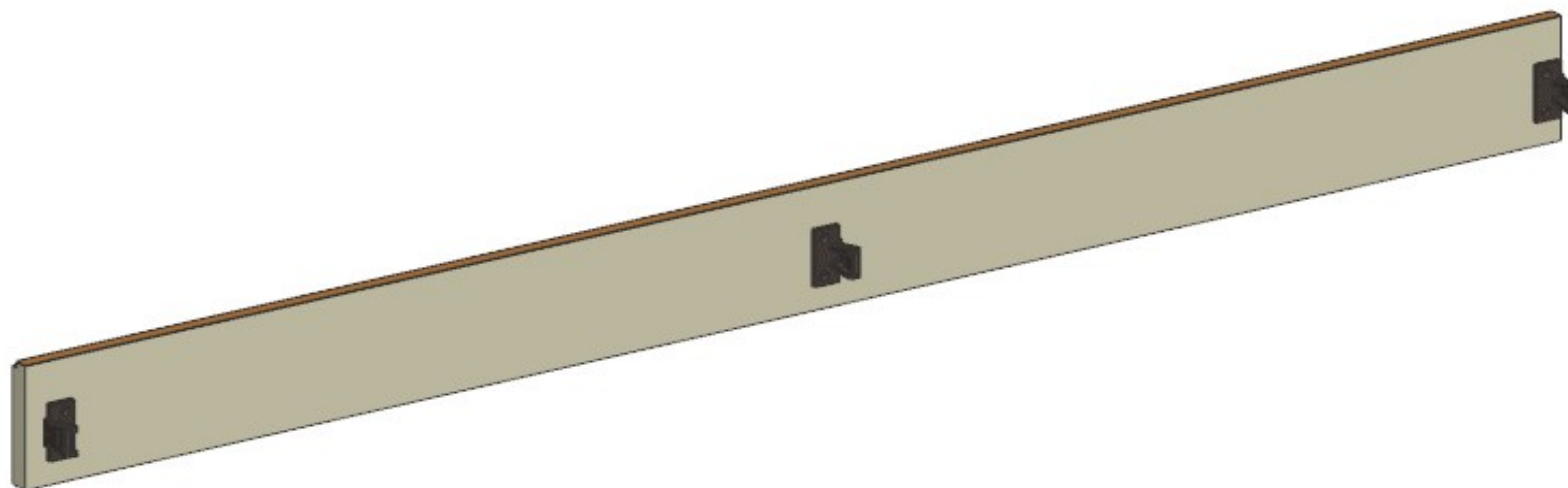

AZ26M

MOD GR5

REV. GR 9

| LOCALE | CODICE | DESCRIZIONE COMPONENTE | FINITURA | Q.TA | OPERATORE |
|--------|----------------|------------------------|-------------------------|------|-----------|
| CUCINA | AZ26M-L01_KF01 | BASE CUCINA PRUA | LACCATO BIANCO RAL 9010 | 2 | Damiano |

1 - L 325 x H.132 x sp 25
2 - L 325 x H.561 x sp 25

6 - L 325 x H.132 x sp 25
7 - L 344 x H.59 x sp 16
8 - L 325 x H 561 x sp 25

MOD. INT. 05
SPIGOLO MANIGLIE

ELIMINATO MF

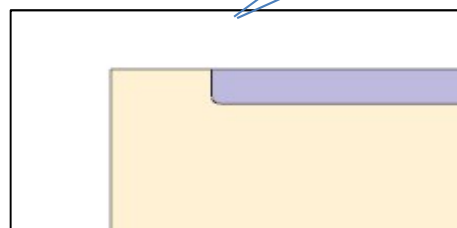

SPIGOLI MANIGLIE
RAGGIATI R10 / 5-4-3-2

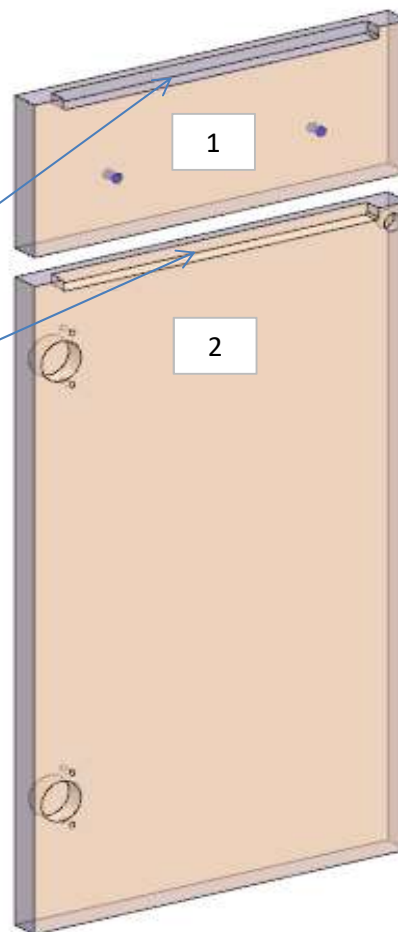

AZ26M

MOD DA GR9

REV. GR 9

| LOCALE | CODICE | DESCRIZIONE COMPONENTE | FINITURA | Q.TA | OPERATORE |
|--------|----------------|------------------------------|-------------------------|------|-----------|
| CUCINA | AZ26M-L01_KG01 | PENSILE CUCINA PRUA 90 Var 2 | LACCATO BIANCO RAL 9010 | 6 | Damiano |

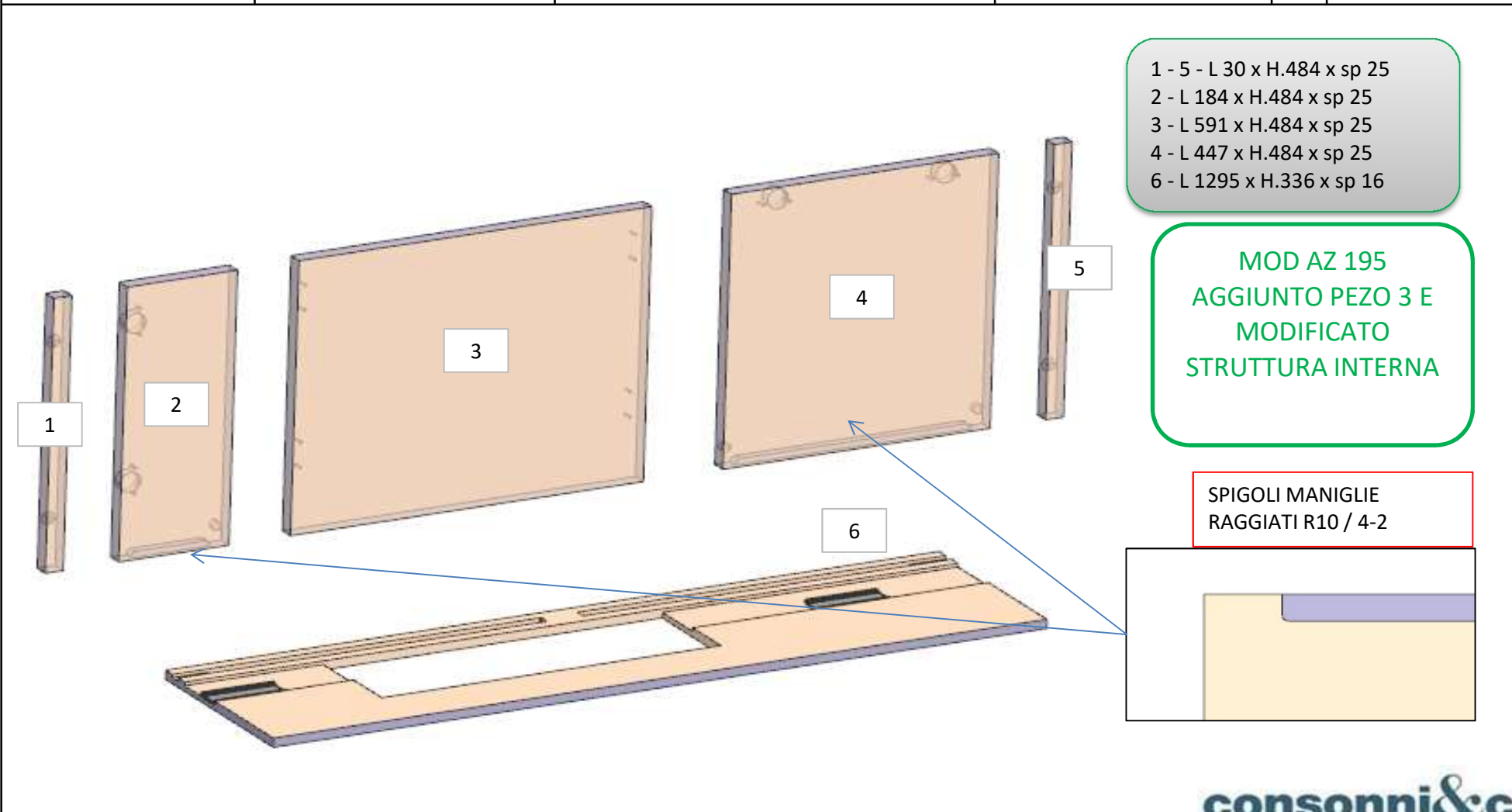

AZ26M

REV. GR 9

| LOCALE | CODICE | DESCRIZIONE COMPONENTE | FINITURA | Q.TA | OPERATORE |
|--------|----------------|-------------------------------------|---------------|------|-----------|
| CUCINA | AZ26M-R01_KH01 | RIV. LATO SX BASE E PENSILE DI PRUA | LASTRA CHIARA | 1 | Damiano |

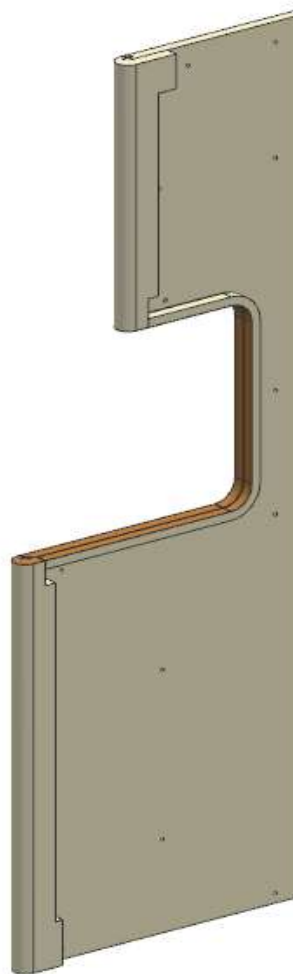

FERRAMENTA:

N° 12 - SPINE diam 8

AZ26M

REV. GR 9

| LOCALE | CODICE | DESCRIZIONE COMPONENTE | FINITURA | Q.TA | OPERATORE |
|--------|----------------|------------------------|----------|------|-----------|
| CUCINA | AZ26M-X01_KI01 | RIV. MARMO PRUA | BETACRIL | 4 | Damiano |

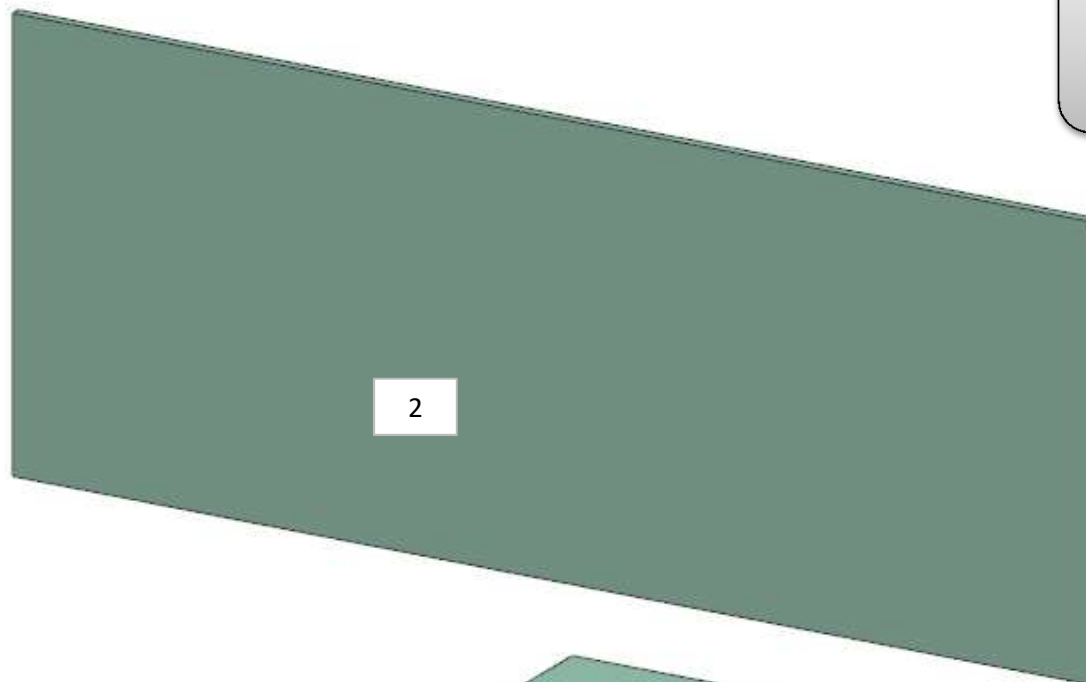
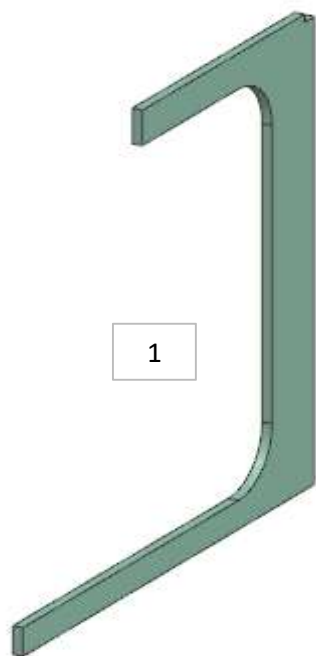

- 1 - L 612 x H.595 x sp 12
- 2 - L 1296 x H.579 x sp 12
- 3 - L 362 x H.595 x sp 12
- 4 - L 290 x H.570 x sp 12

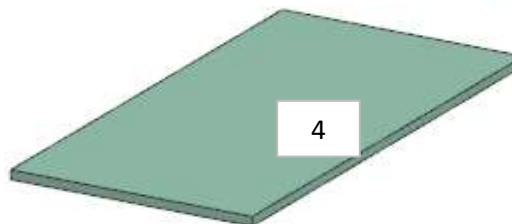

AZ26M

REV. GR 9

| LOCALE | CODICE | DESCRIZIONE COMPONENTE | FINITURA | Q.TA | OPERATORE |
|--------|----------------|------------------------------------|-------------------------|------|-----------|
| CUCINA | AZ26M-L01_KJ01 | STRUTTURA CIELINO PORTA SCORREVOLE | LACCATO BIANCO RAL 9016 | 2 | Damiano |

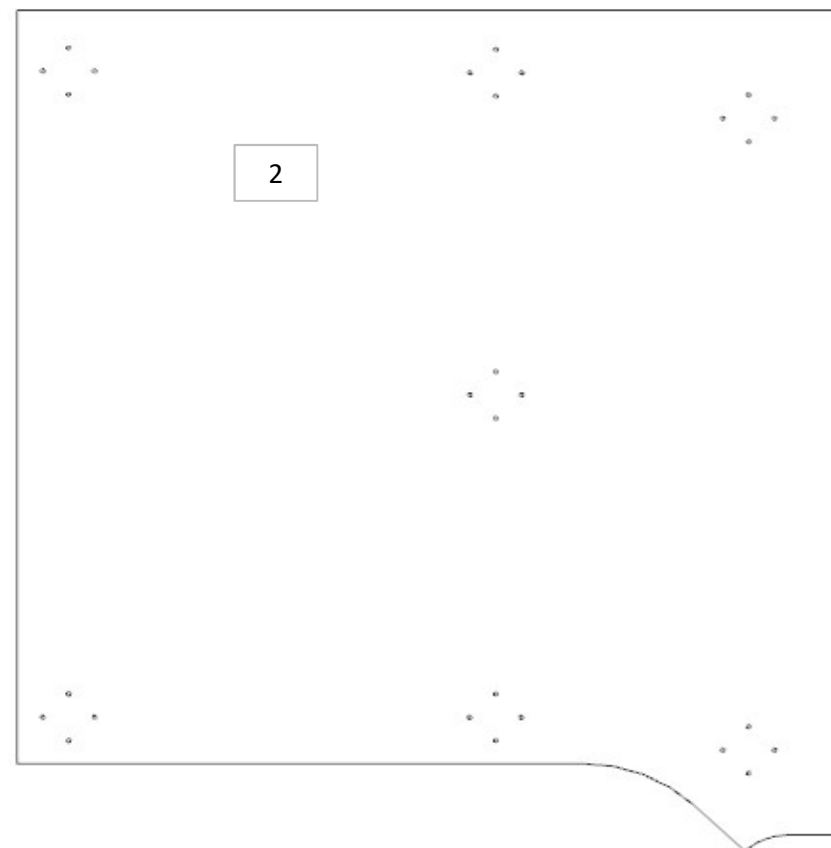
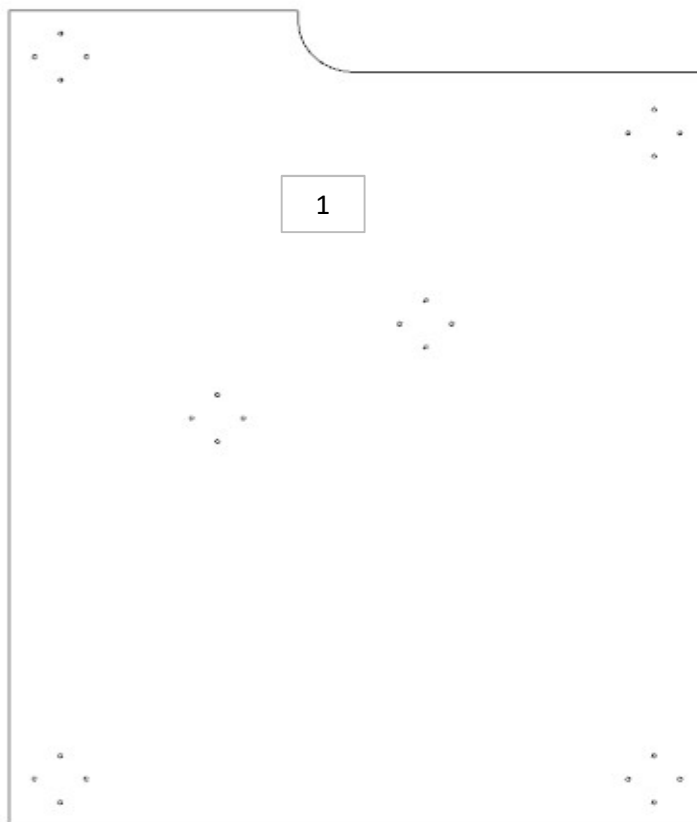

AZ26M

MOD GR5

REV. GR 9

| LOCALE | CODICE | DESCRIZIONE COMPONENTE | FINITURA | Q.TA | OPERATORE |
|--------|-----------------|------------------------|-------------------------|------|-----------|
| CUCINA | AZ26M-L01_KKF01 | FORNO 90 Var 2 | LACCATO BIANCO RAL 9010 | 8 | Damiano |

- 1 - L 1320 x H.76 x sp 16
- 2 - L 344 x H.59 x sp 16
- 3 - 4 - L 445 x H.219 x sp 25
- 5 - L 897 x H.44 x sp 16
- 6 - L 67 x H.718 x sp 26
- 7 - L 80 x H.713 x sp 16
- 8 - L 64 x H.713 x 117

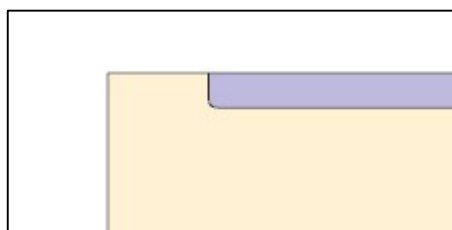
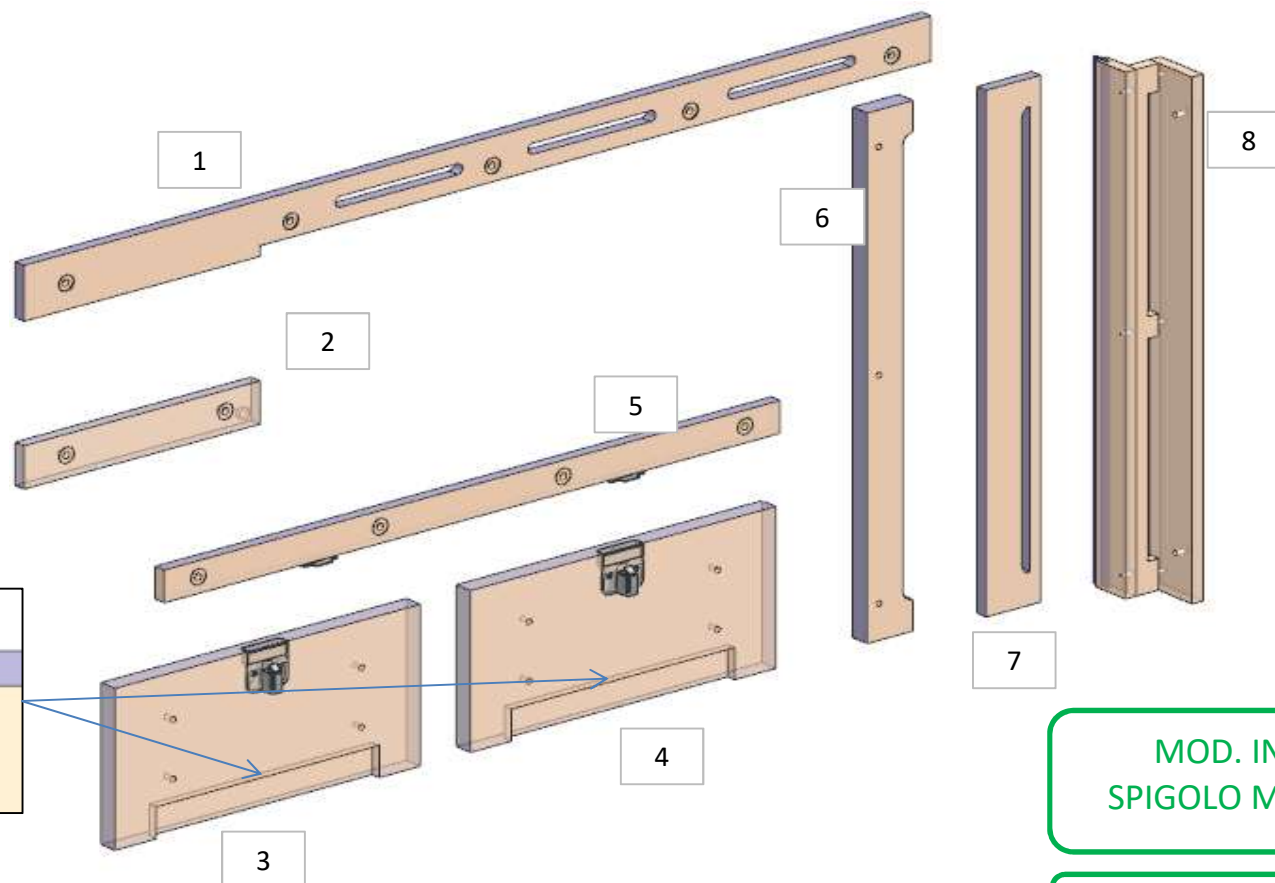

SPIGOLI MANIGLIE
RAGGIATI R10 / 5-4-3-2

MOD. INT. 05
SPIGOLO MANIGLIE

ELIMINATO MF

consonni&c

AZ26M

MOD GR5

REV. GR 9

| LOCALE | CODICE | DESCRIZIONE COMPONENTE | FINITURA | Q.TA | OPERATORE |
|--------|-----------------|------------------------------|-------------------------|------|-----------|
| CUCINA | AZ26M-L01_KKG01 | PENSILE CUCINA PRUA 60 Var 1 | LACCATO BIANCO RAL 9010 | 5 | Damiano |

1 - 4 - L 30 x H.484 x sp 25
2 - 3 - L 613 x H.484 x sp 25
5 - L 1295 x H.336 x sp 16

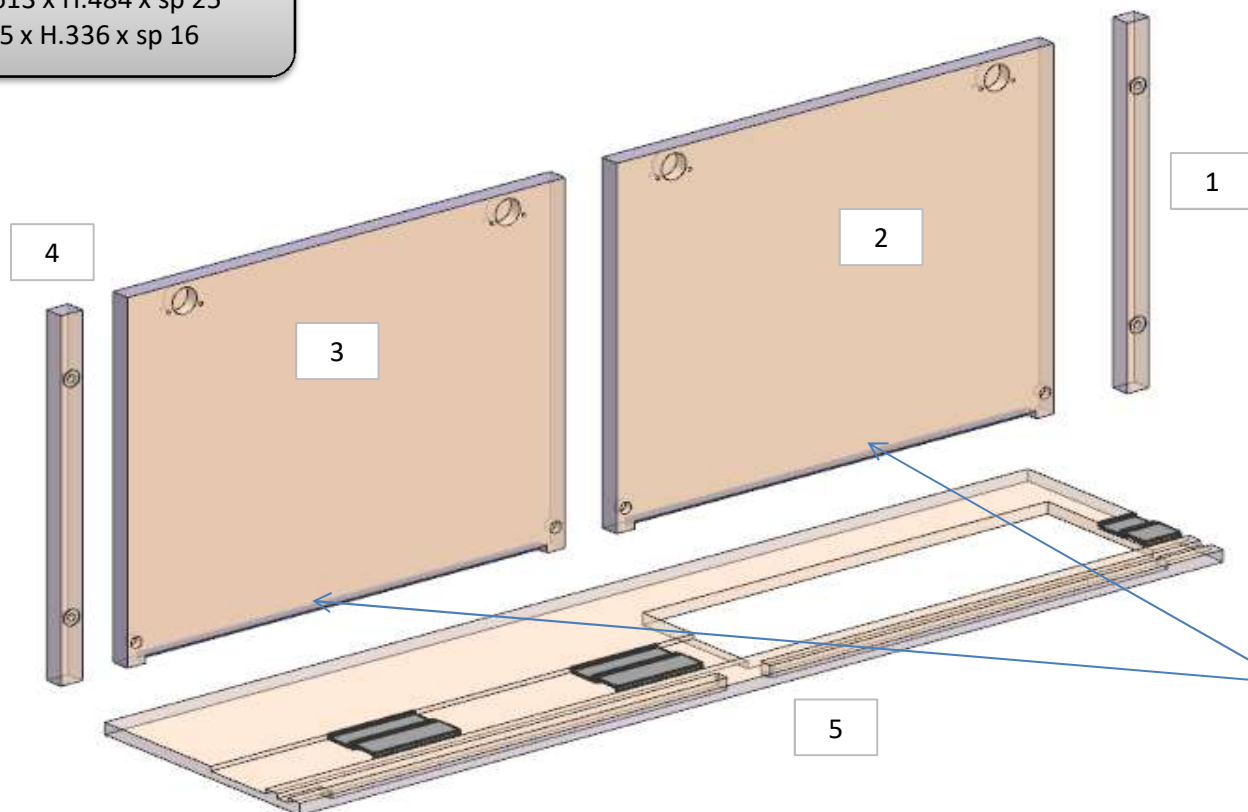

MOD. INT. 05
SPIGOLO MANIGLIE

ELIMINATO MF

SPIGOLI MANIGLIE
RAGGIATI R10 / 5-4-3-2

consonni&c

AZ26M

MOD GR5

REV. GR 9

| LOCALE | CODICE | DESCRIZIONE COMPONENTE | FINITURA | Q.TA | OPERATORE |
|--------|-----------------|------------------------|-------------------------|------|-----------|
| CUCINA | AZ26M-L01_KKK01 | FORNO 60 Var 1 | LACCATO BIANCO RAL 9010 | 7 | Damiano |

SPIGOLI MANIGLIE
RAGGIATI R10 / 5-4-3-2

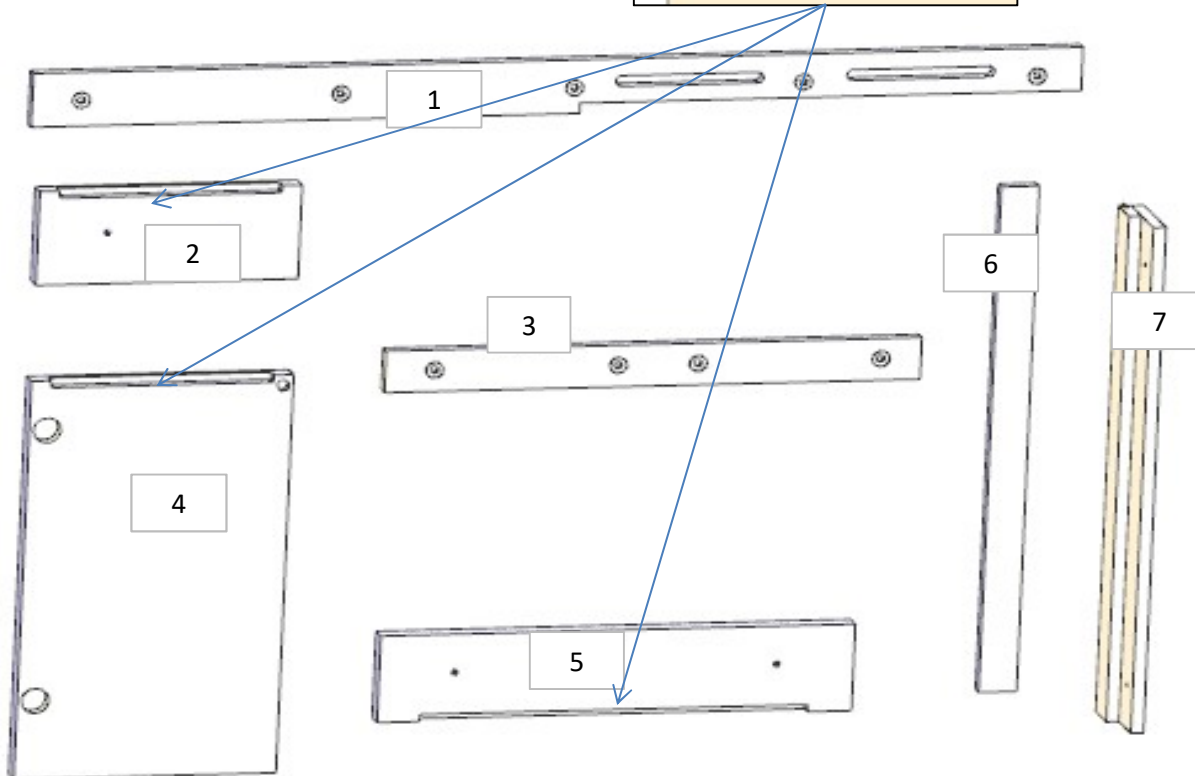
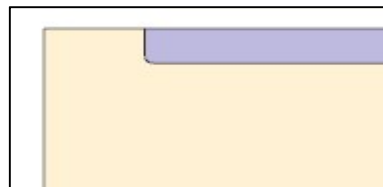

- 1 - L 1320 x H.76 x sp 16
- 2 - L 330 x H.132 x sp 25
- 3 - L 674 x H.59 x sp 16
- 4 - L 330 x H.561 x sp 25
- 5 - L 597 x H.122 x sp 25
- 6 - L 712 x H.47 x sp 16
- 7 - L 712 x H.113 x sp 16

MOD. INT. 05
SPIGOLO MANIGLIE

MOD. INT. 30
AGGIUNTO MF
PORTAPENTOLE

ELEMENTO DA MONTARE con:
AZ26M-L01_KKK01_06
AZ26M-L01_KKK01_07
spedire con un unico imballo

consonni&c

AZ26M

REV. GR 9

| LOCALE | CODICE | DESCRIZIONE COMPONENTE | FINITURA | Q.TA | OPERATORE |
|--------|-----------------|-------------------------------|----------|------|-----------|
| CUCINA | AZ26M-X01_KKQ01 | TOP BASE CUCINA PRUA 60 Var 1 | BETACRIL | 1 | Damiano |

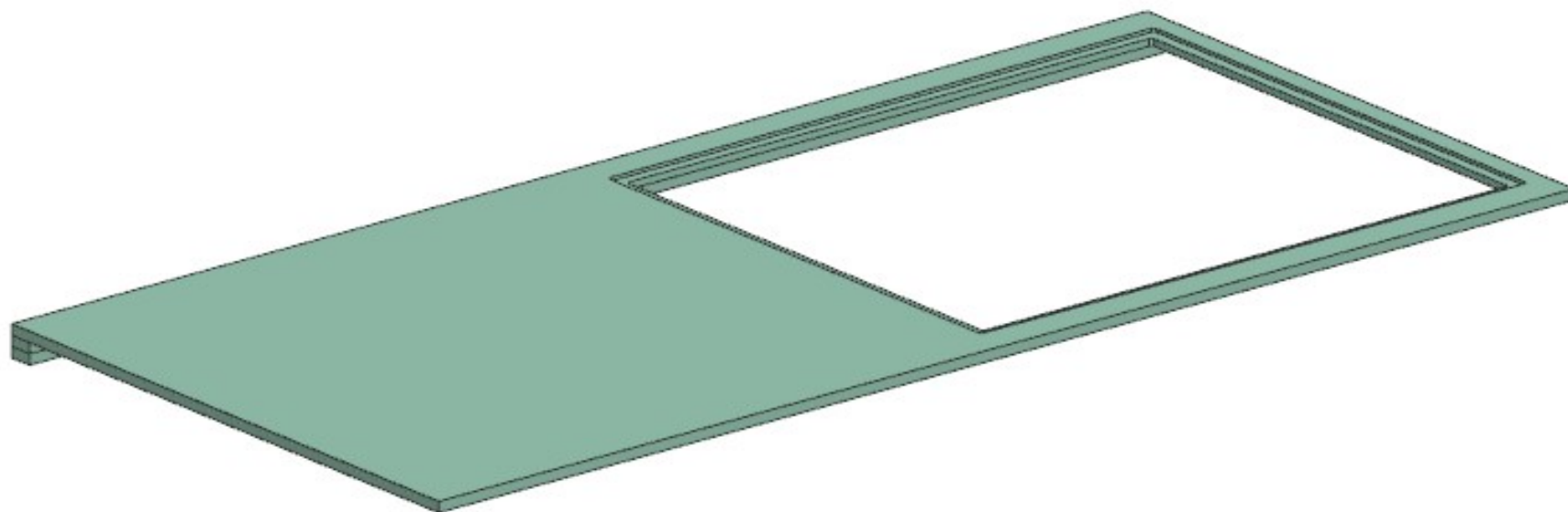

consonni&c

AZ26M

REV. GR 9

| LOCALE | CODICE | DESCRIZIONE COMPONENTE | FINITURA | Q.TA | OPERATORE |
|--------|----------------|------------------------|----------|------|-----------|
| CUCINA | AZ26M-X01_KR01 | TOP BASE CUCINA POPPA | BETACRIL | 1 | Damiano |

1 -L 1589 x H 36 x 600

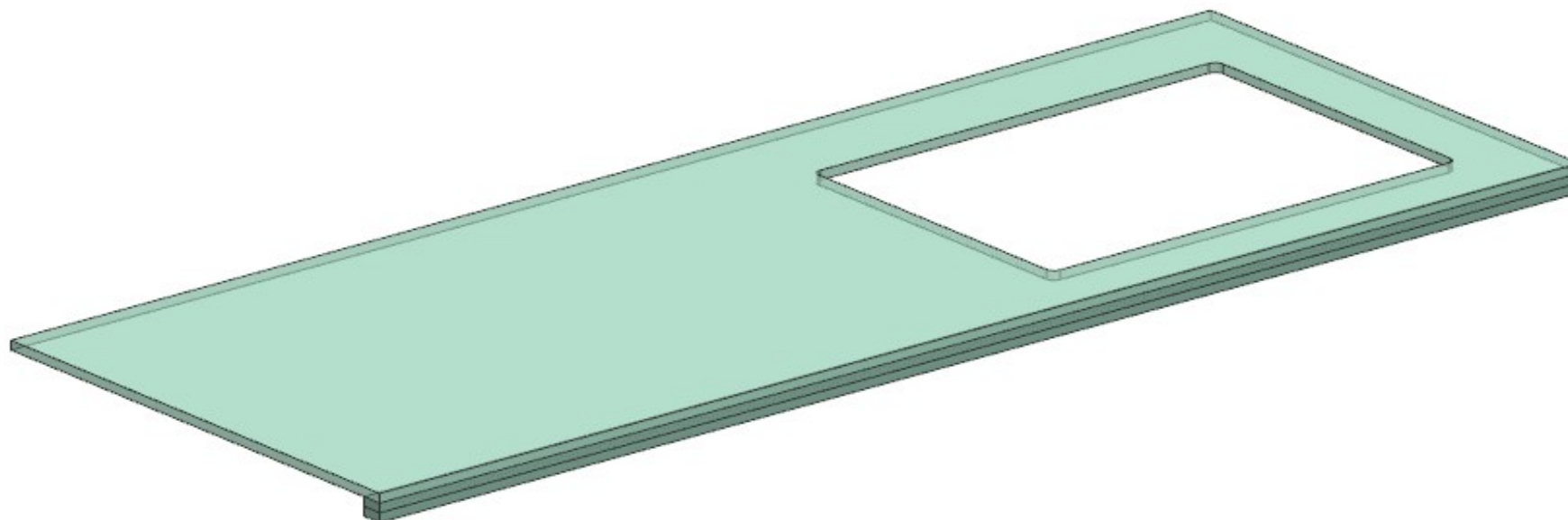

AZ26M

REV. 01-2023

REV. GR 9

| LOCALE | CODICE | DESCRIZIONE COMPONENTE | FINITURA | Q.TA | OPERATORE |
|--------|----------------|-------------------------|---------------|------|-----------|
| CUCINA | AZ26M-R01_KN01 | PLENUM MOBILE BICCHIERI | LASTRA CHIARA | 1 | Damiano |

1 - L 1182 x H 96 x sp 25

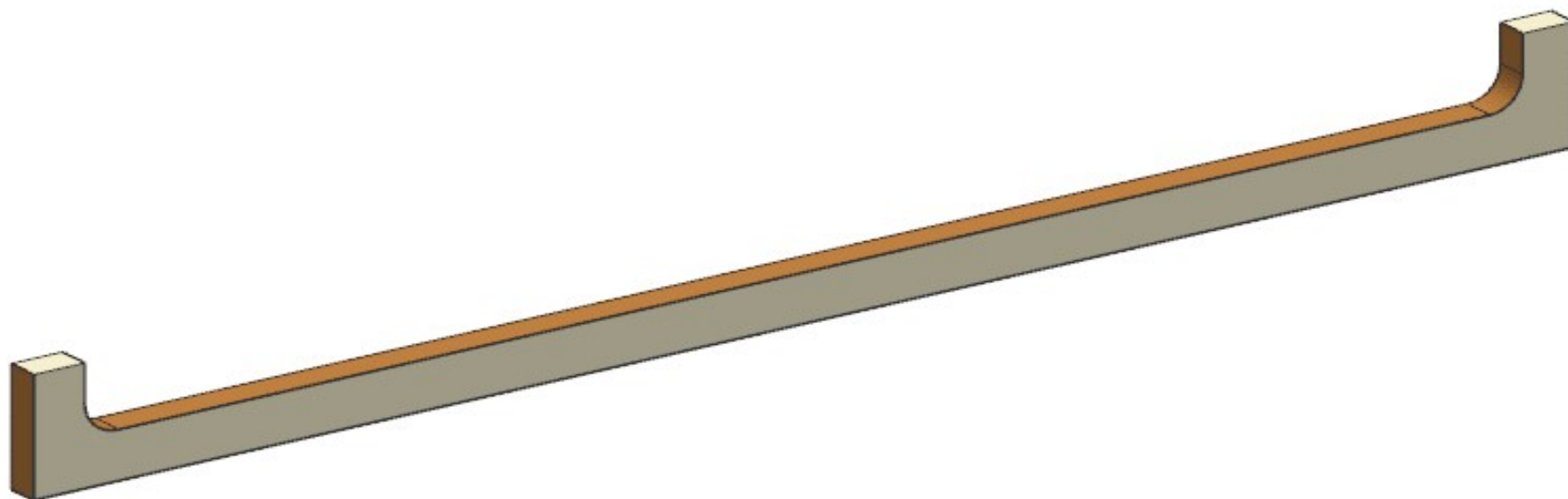

AZ26M

REV. 01-2023

REV. GR 10

| LOCALE | CODICE | DESCRIZIONE COMPONENTE | FINITURA | Q.TA | OPERATORE |
|--------|----------------|-------------------------|---------------------------|------|-----------|
| CUCINA | AZ26M-L01_KN01 | PLENUM MOBILE BICCHIERI | LACCATO BRONZO\ GREZZO | 1 | Damiano |

- 1 - L..1235 x H.133 x sp 19
- 2 - L..1049 x H.30 x sp 20

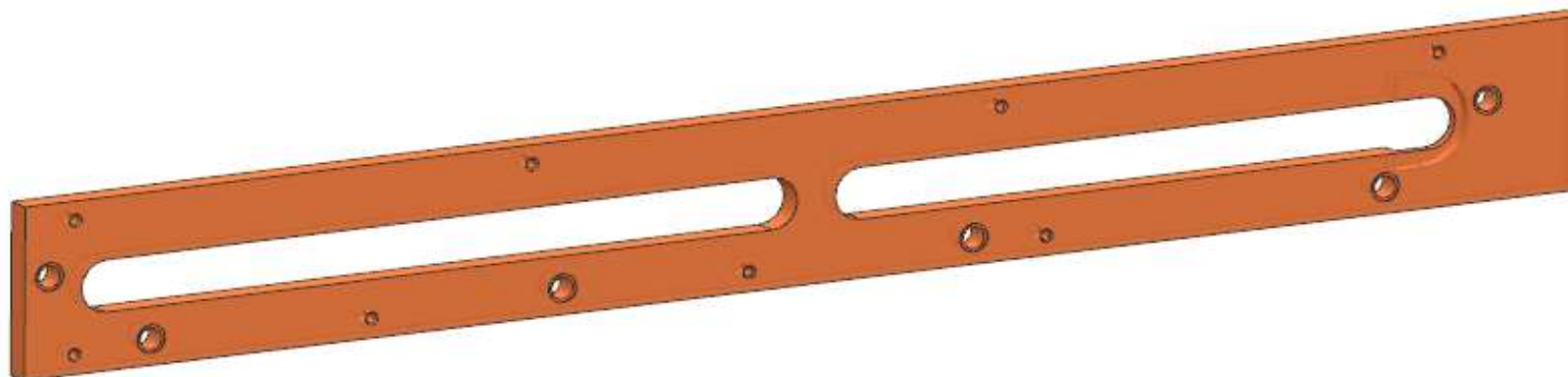

AZ26M

REV. 01-2023

REV. GR 9

| LOCALE | CODICE | DESCRIZIONE COMPONENTE | FINITURA | Q.TA | OPERATORE |
|--------|----------------|------------------------|---------------|------|-----------|
| CUCINA | AZ26M-R01_KO01 | CASSA FRIGO AGGIUNTIVO | LASTRA CHIARA | 5 | Damiano |

- 1 - L 130 x H 2026 x sp 25
- 2 - L 573 x H 1923 x sp 25
- 3 - L 70 x H 1547 x sp 16
- 4 - L 576 x H 383 x sp 41
- 5 - L 65 x H 1547 x sp 16

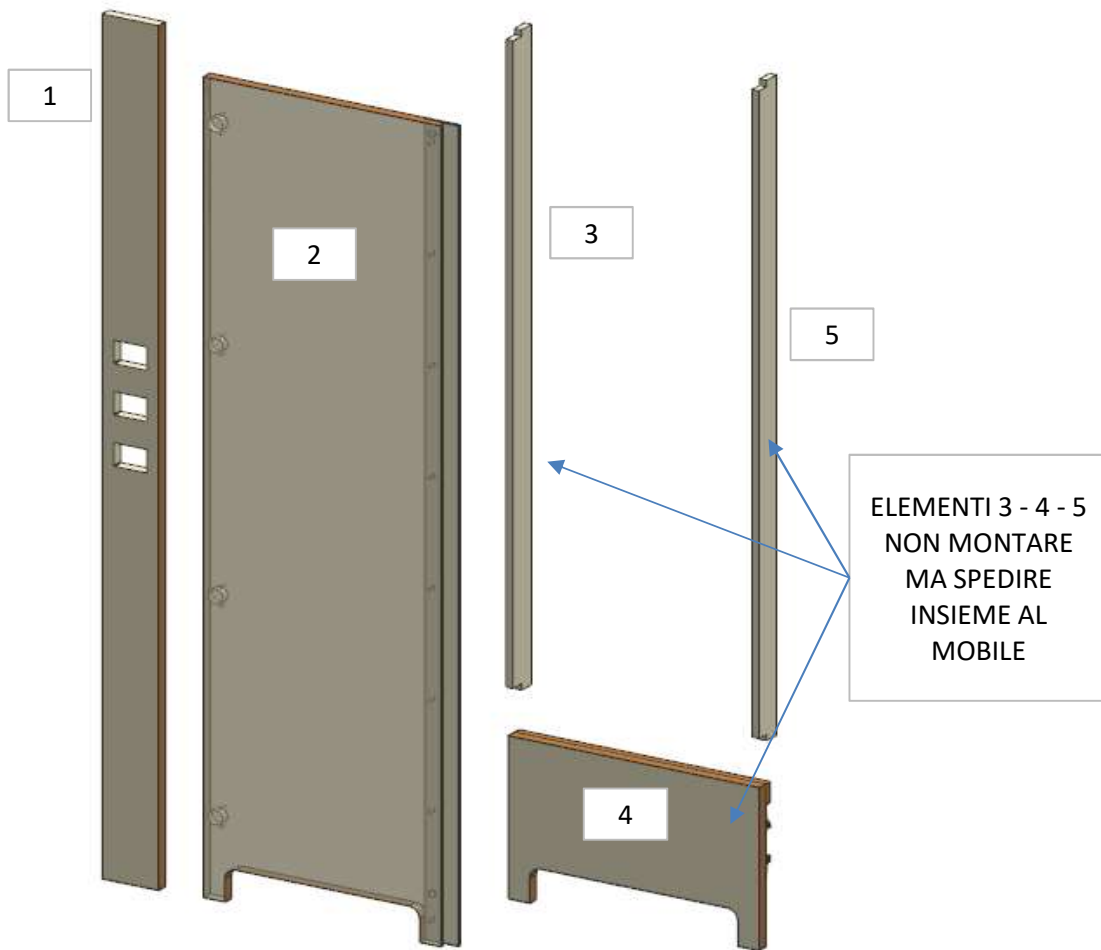

AZ26M

REV. 01-2023

REV. GR 9

| LOCALE | CODICE | DESCRIZIONE COMPONENTE | FINITURA | Q.TA | OPERATORE |
|--------|----------------|------------------------|---------------|------|-----------|
| CUCINA | AZ26M-X01_KO01 | CASSA FRIGO AGGIUNTIVO | LAMINATO NERO | 3 | Damiano |

1 - 3 - L 181 x H 100 x sp 2
2 - L 609 x H 100 x sp 16

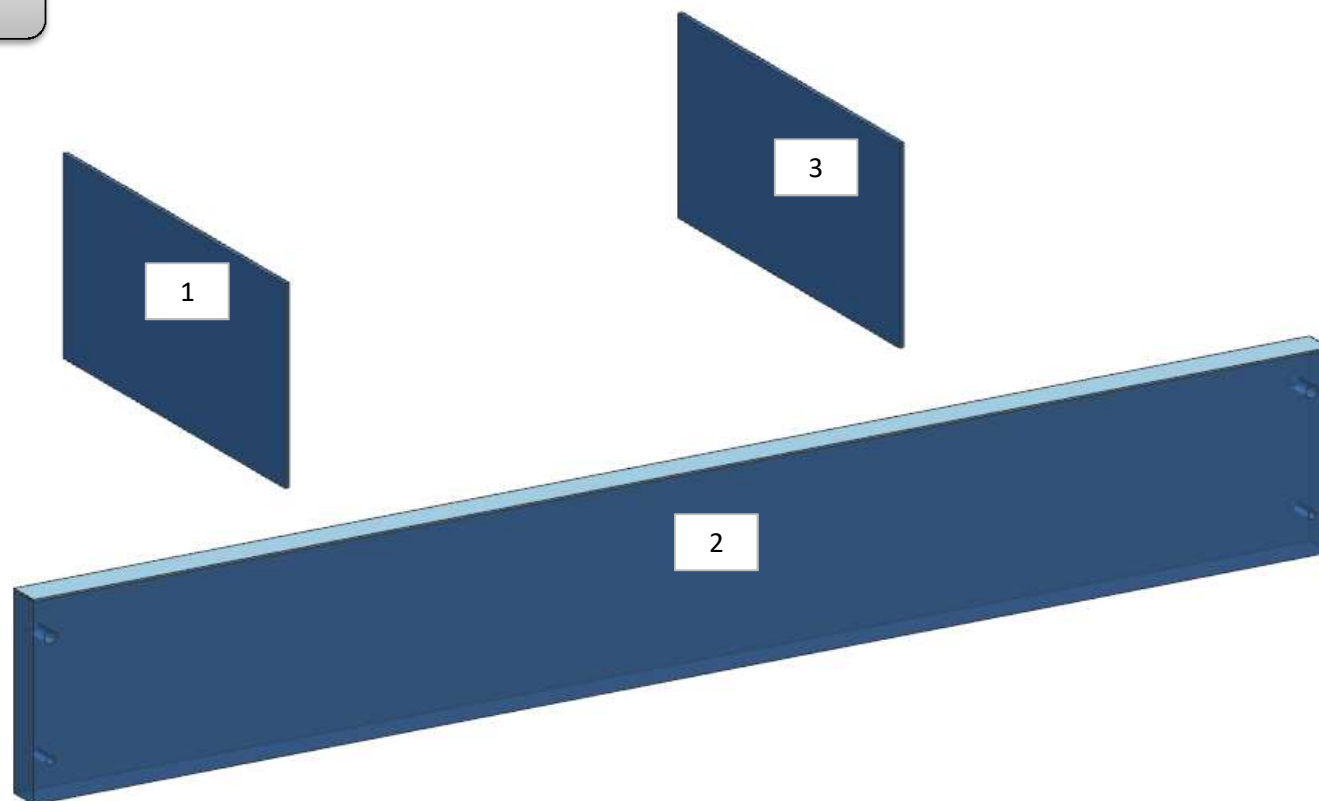

AZ26M

REV. 01-2023

REV. GR 9

| LOCALE | CODICE | DESCRIZIONE COMPONENTE | FINITURA | Q.TA | OPERATORE |
|--------|----------------|--|---------------|------|-----------|
| CUCINA | AZ26M-R01_KP01 | CASSA RICIRCOLO ARIA FRIGO AGGIUNTIVO | LASTRA CHIARA | 1 | Damiano |

1 - L 577 x H 96 x sp 25

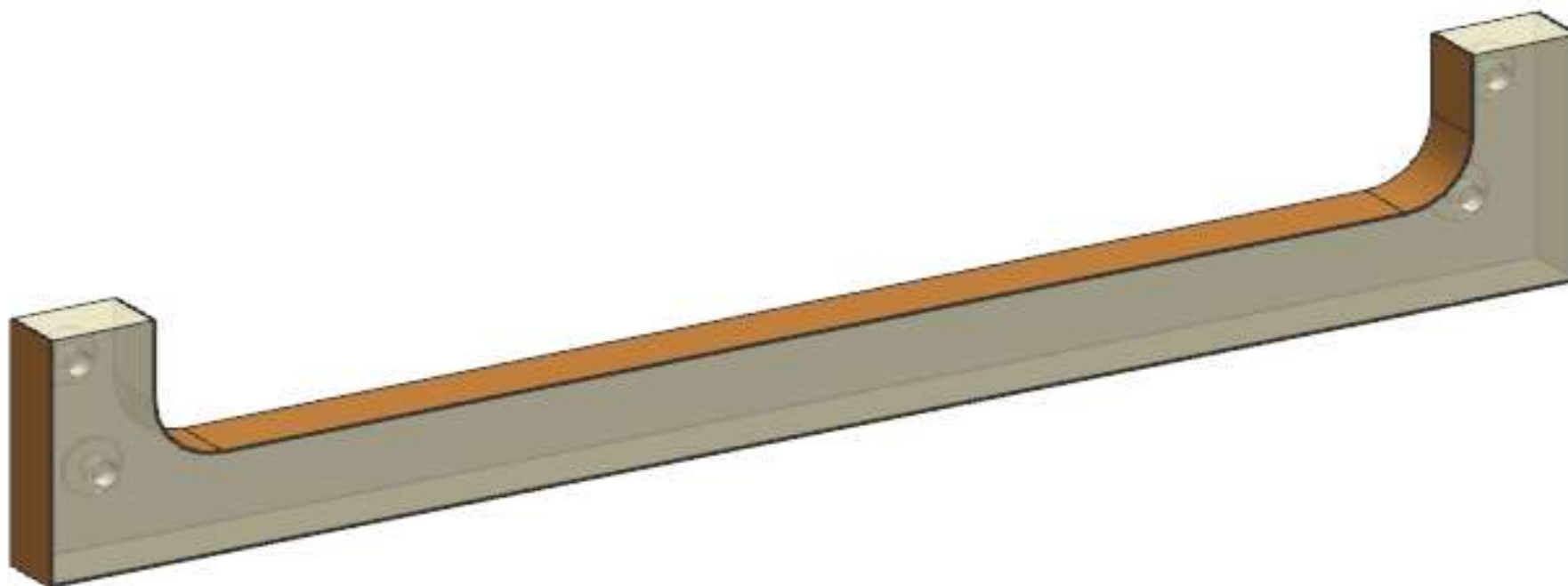

AZ26M

REV. 01-2023

REV. GR 9

| LOCALE | CODICE | DESCRIZIONE COMPONENTE | FINITURA | Q.TA | OPERATORE |
|--------|----------------|--|---------------------------|------|-----------|
| CUCINA | AZ26M-LO1_KP01 | CASSA RICIRCOLO ARIA FRIGO AGGIUNTIVO | LACCATO BRONZO\ GREZZO | 2 | Damiano |

1 - L..609 x H.117 x sp 19
2 - L..609 x H.30 x sp 20

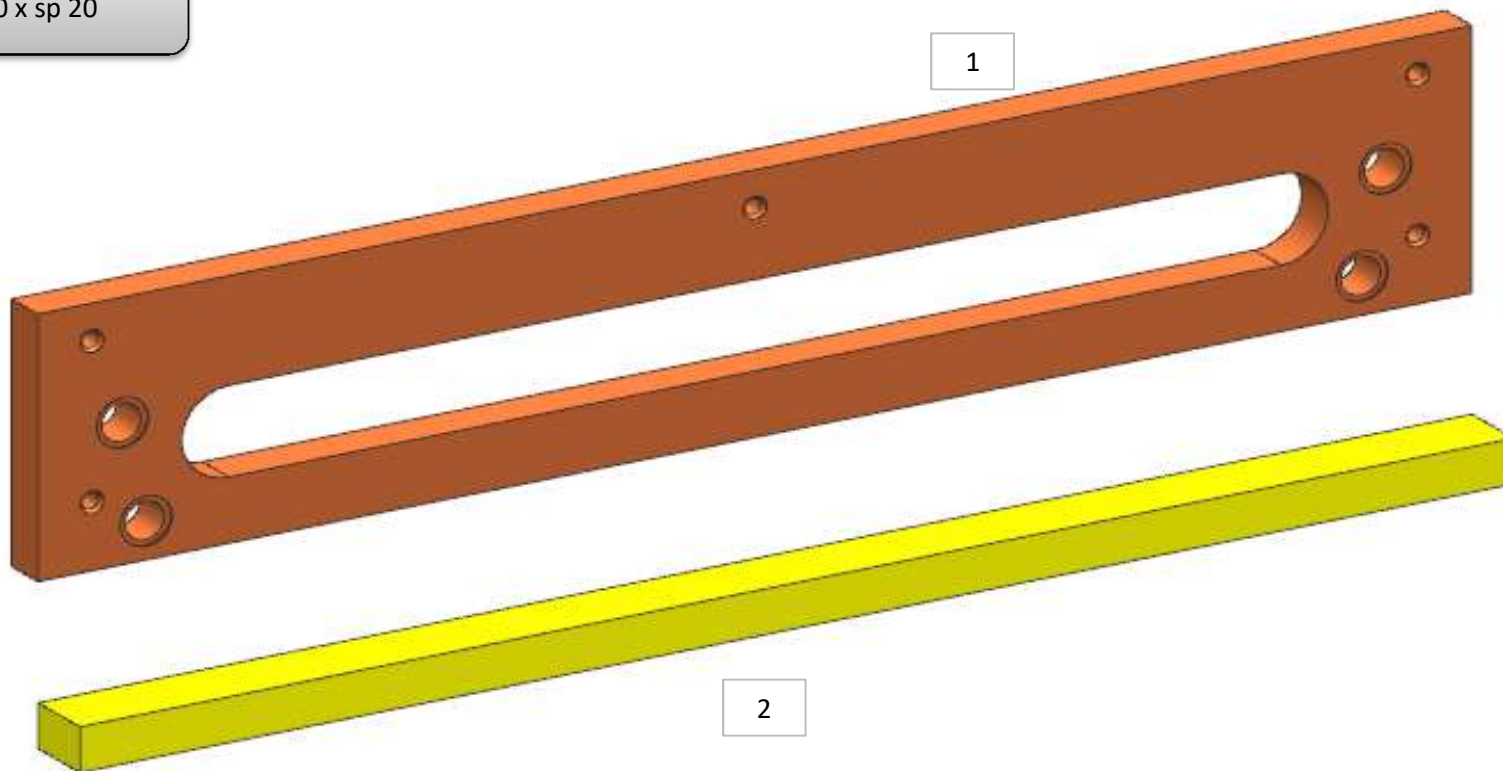

AZ26M

REV. GR 9

| LOCALE | CODICE | DESCRIZIONE COMPONENTE | FINITURA | Q.TA | OPERATORE |
|--------|----------------|-------------------------------|----------|------|-----------|
| CUCINA | AZ26M-X01_KQ01 | TOP BASE CUCINA PRUA 90 Var 2 | BETACRIL | 1 | Damiano |

1 -L 1296x H 36 x 599

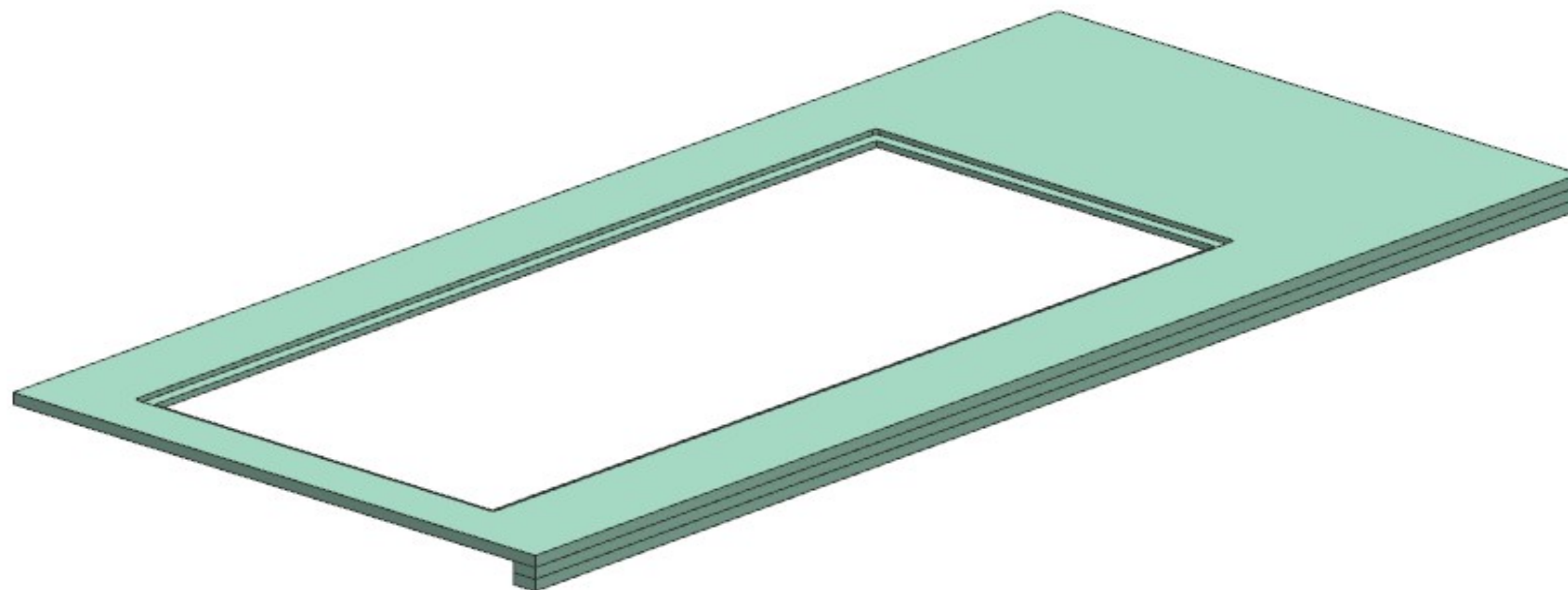

consonni&c

AZ26M

REV. GR 9

| LOCALE | CODICE | DESCRIZIONE COMPONENTE | FINITURA | Q.TA | OPERATORE |
|--------|---------------|-----------------------------------|----------|------|-----------|
| CUCINA | AZ26M-MF_KS01 | RIV. LATO DX BASE PENSILE DI PRUA | | | Damiano |

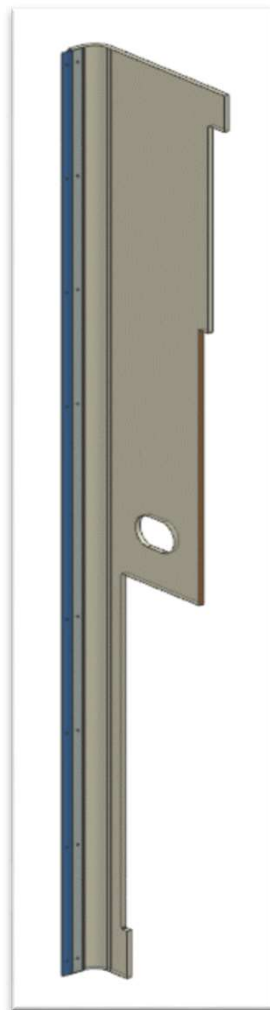

consonni&c

AZ26M

REV. GR 9

| LOCALE | CODICE | DESCRIZIONE COMPONENTE | FINITURA | Q.TA | OPERATORE |
|--------|----------------|-----------------------------------|---------------|------|-----------|
| CUCINA | AZ26M-R01_KS01 | RIV. LATO DX BASE PENSILE DI PRUA | LASTRA CHIARA | 1 | Damiano |

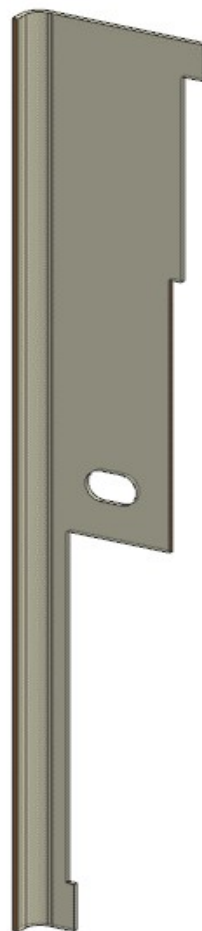

ELEMENTO DA
MONTARE con:
X01_KS01
spedire con un
unico imballo

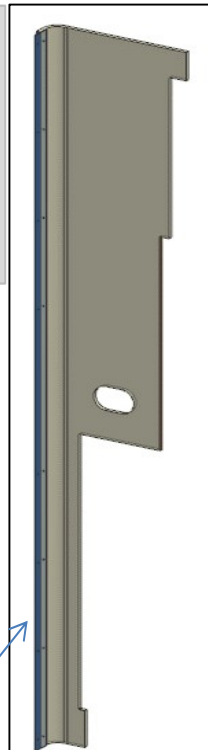

X01_KS01

consonni&c

AZ26M

REV. GR 9

| LOCALE | CODICE | DESCRIZIONE COMPONENTE | FINITURA | Q.TA | OPERATORE |
|--------|----------------|-----------------------------------|---------------|------|-----------|
| CUCINA | AZ26M-X01_KS01 | RIV. LATO DX BASE PENSILE DI PRUA | LAMINATO NERO | 1 | Dante |

1 -L 2026 x H 50 x sp 2



ELEMENTO DA
MONTARE con:
R01_KS01
spedire con un
unico imballo

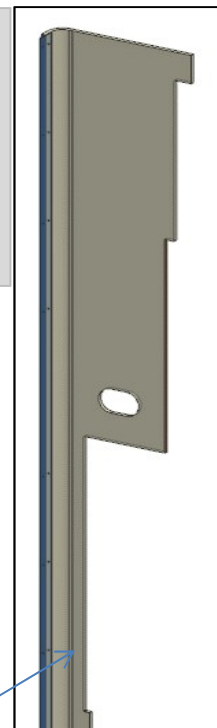

R01_KS01

consonni&c

AZ26M

REV. GR 9

| LOCALE | CODICE | DESCRIZIONE COMPONENTE | FINITURA | Q.TA | OPERATORE |
|--------|----------------|--|---------------|------|-----------|
| CUCINA | AZ26M-R01_KT01 | RIV. PARATIA PORTA SCORR. DAILY TOILET | LASTRA CHIARA | 1 | Damiano |

1 -L 587 x H 2026 x sp 11

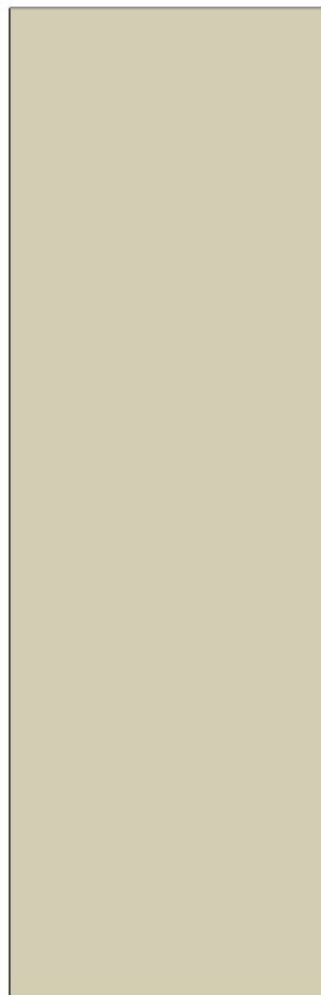

AZ26M

REV. GR 9

| LOCALE | CODICE | DESCRIZIONE COMPONENTE | FINITURA | Q.TA | OPERATORE |
|--------|----------------|------------------------------|---------------|------|-----------|
| CUCINA | AZ26M-R01_KU01 | RIV. PARATIA INGRESSO CUCINA | LASTRA CHIARA | 1 | Damiano |

1 -L 489 x H 2026 x sp 11

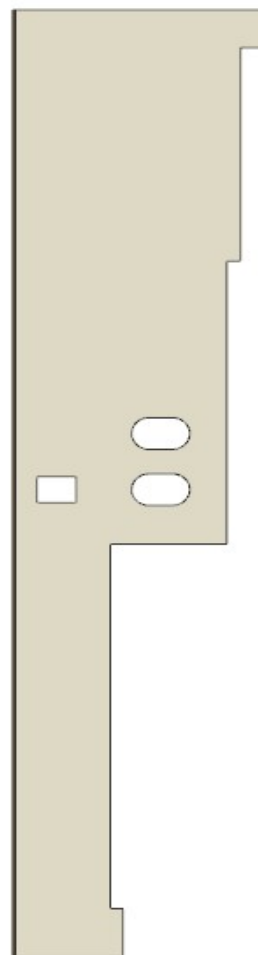

consonni&c

AZ26M

MOD DA GR9

REV. GR 9

| LOCALE | CODICE | DESCRIZIONE COMPONENTE | FINITURA | Q.TA | OPERATORE |
|--------|----------------|------------------------------------|---------------|------|-----------|
| CUCINA | AZ26M-R01_KV01 | RIV. INFERIORE PORTA SCORR. CUCINA | LASTRA CHIARA | 1 | Damiano |

1 -L 952 x H 226 x sp 44

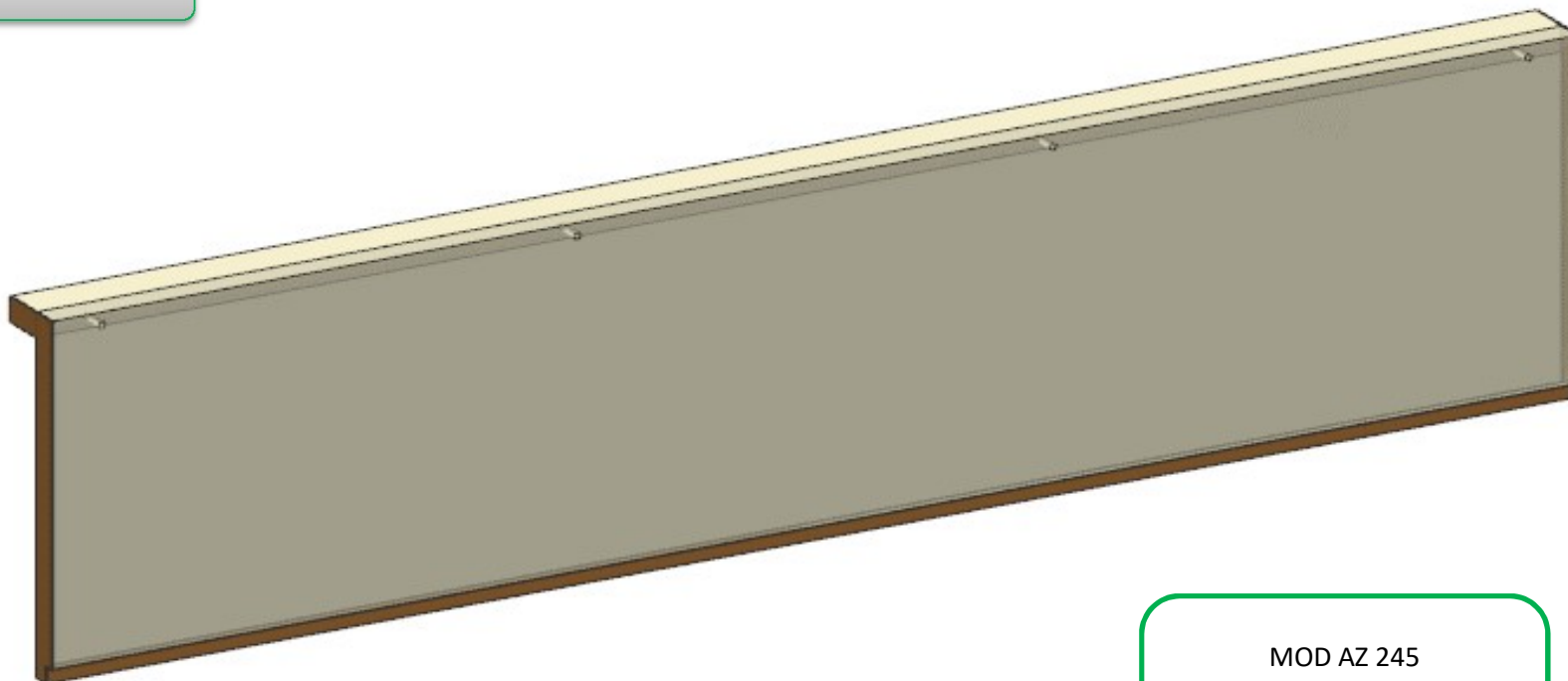

FERRAMENTA:

N° 1 - L IN ALLUMINIO
ANGOLARE sp 2mm 25X25

MOD AZ 245
ALLUNGATO SIA LEGNO CHE
SOGLIA IN INOX PER
XCAKLETTATURA IN OPERA

AZ26M

MOD DA GR9

REV. GR 9

| LOCALE | CODICE | DESCRIZIONE COMPONENTE | FINITURA | Q.TA | OPERATORE |
|--------|----------------|------------------------------------|-----------|------|-----------|
| CUCINA | AZ26M-A01_KV01 | RIV. INFERIORE PORTA SCORR. CUCINA | ALLUMINIO | 1 | Damiano |

1 -L 952 x H 25 x sp 2

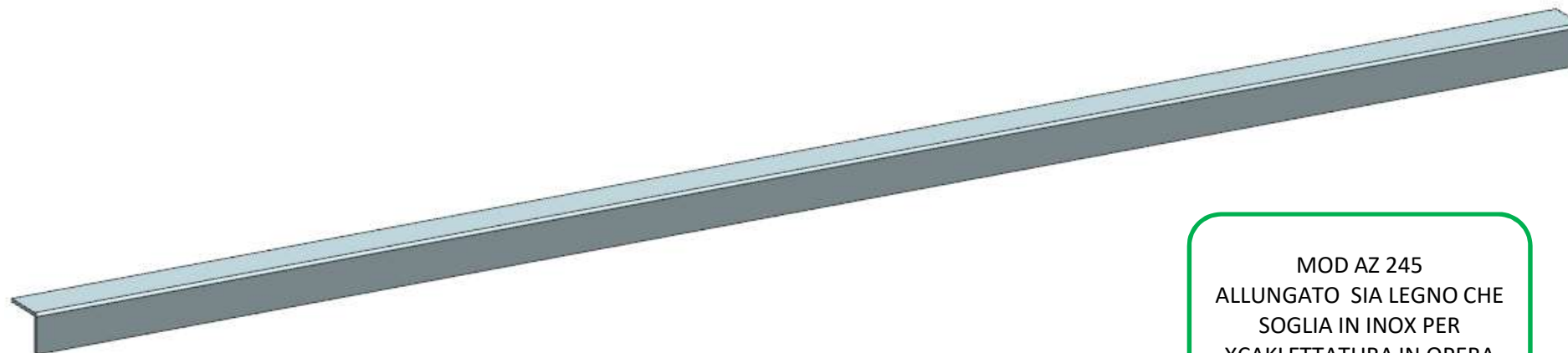

MOD AZ 245
ALLUNGATO SIA LEGNO CHE
SOGLIA IN INOX PER
XCAKLETTATURA IN OPERA

AZ26M

REV. GR 9

| LOCALE | CODICE | DESCRIZIONE COMPONENTE | FINITURA | Q.TA | OPERATORE |
|--------|----------------|----------------------------|-------------------------|------|-----------|
| CUCINA | AZ26M-L01_KW01 | STRUTTURA CIELINO INGRESSO | LACCATO BIANCO RAL 9016 | 4 | Damiano |

- 1 - L..1569 x H.254 x sp 10
- 2 - L..567 x H.812 x sp 10
- 3 - L..721 x H.874 x sp 10
- 4 - L..1312 x H 254 x sp 10

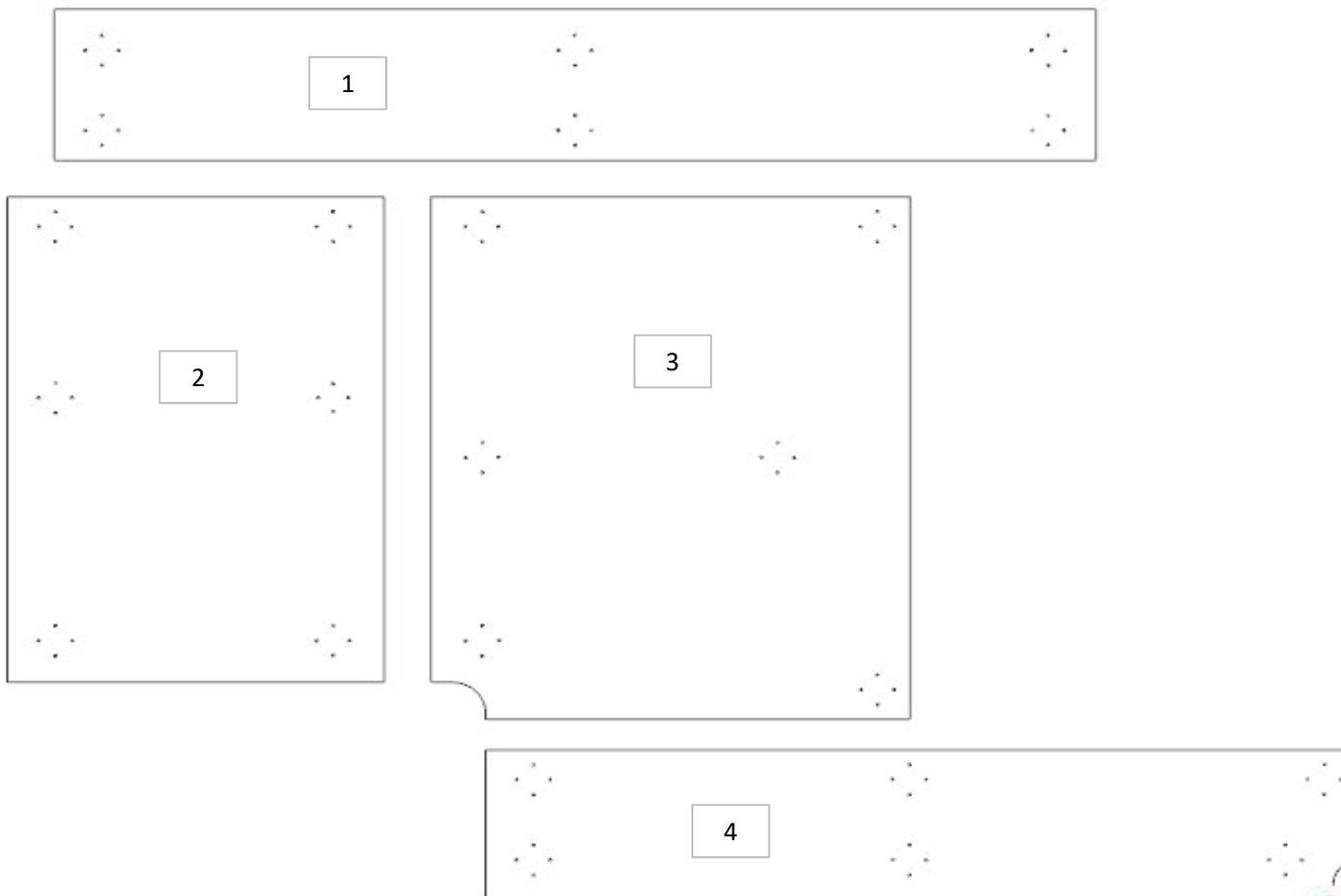

consonni&c

AZ26M

REV. 01-2023

REV. GR 9

| LOCALE | CODICE | DESCRIZIONE COMPONENTE | FINITURA | Q.TA | OPERATORE |
|--------|----------------|--|----------------------------|------|-----------|
| CUCINA | AZ26M-L01_KX01 | STRUTTURA CIELINO SOPRA PENSILE POPPA | LACCATO BIANCO RAL 9016 | 1 | Damiano |

1 - L. 1569 x H.78 x 70

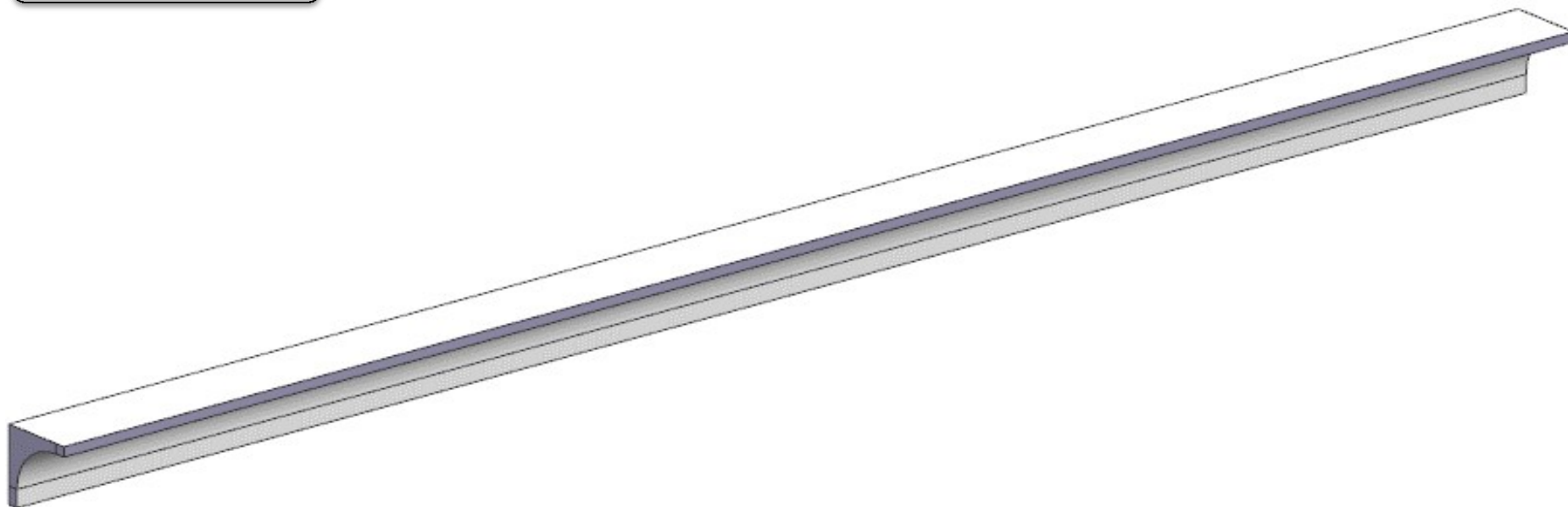

AZ26M

REV. GR 9

| LOCALE | CODICE | DESCRIZIONE COMPONENTE | FINITURA | Q.TA | OPERATORE |
|--------|----------------|--|---------------|------|-----------|
| CUCINA | AZ26M-X01_KX01 | STRUTTURA CIELINO SOPRA PENSILE POPPA | LAMINATO NERO | 4 | Dante |

1 - 3 - L 82 x H 50 x sp 2
2 - 4 - L 102 x H 50 x sp 2

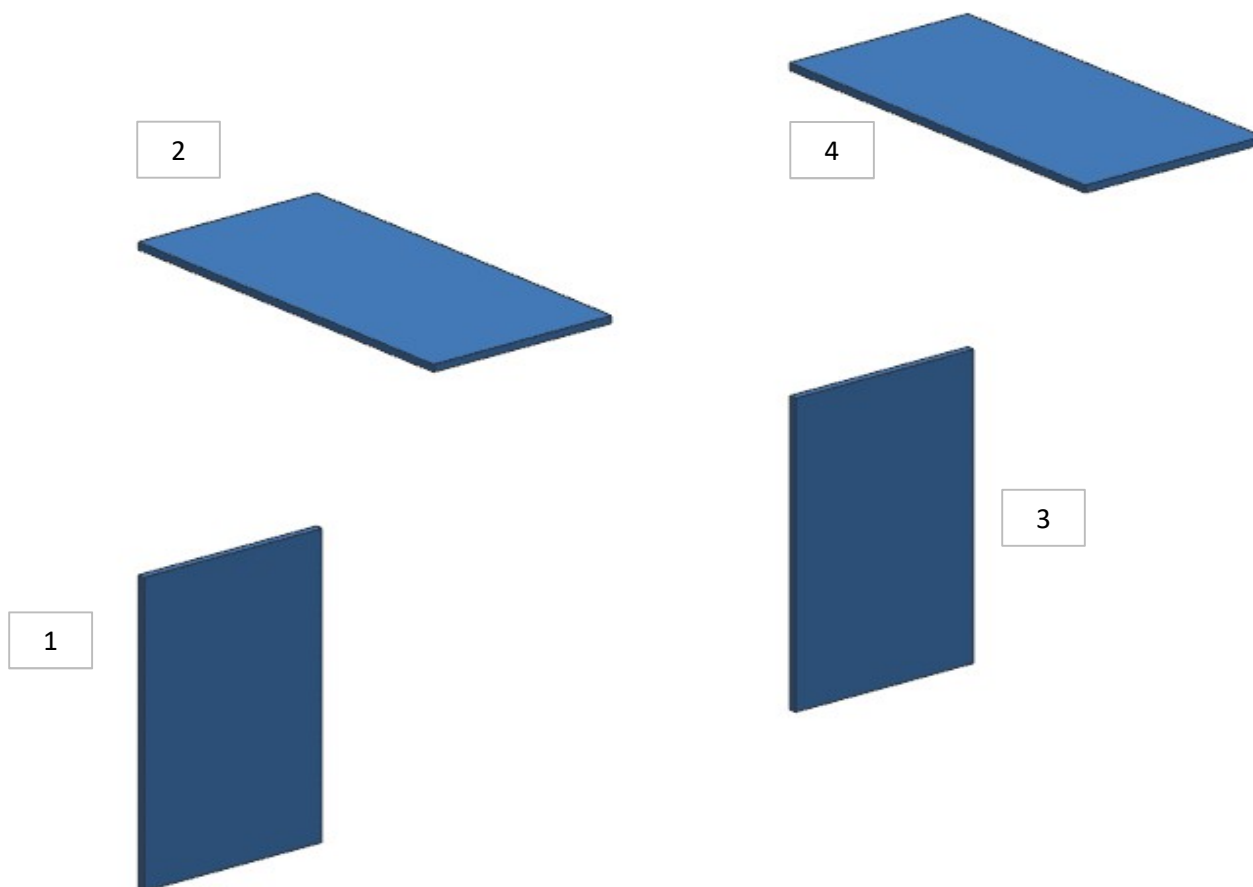

AZ26M

REV. GR 9

| LOCALE | CODICE | DESCRIZIONE COMPONENTE | FINITURA | Q.TA | OPERATORE |
|--------|---------------|--------------------------------------|----------|------|-----------|
| CUCINA | AZ26M-MF_KY01 | STRUTTURA CIELINO SOPRA PENSILE PRUA | | | Damiano |

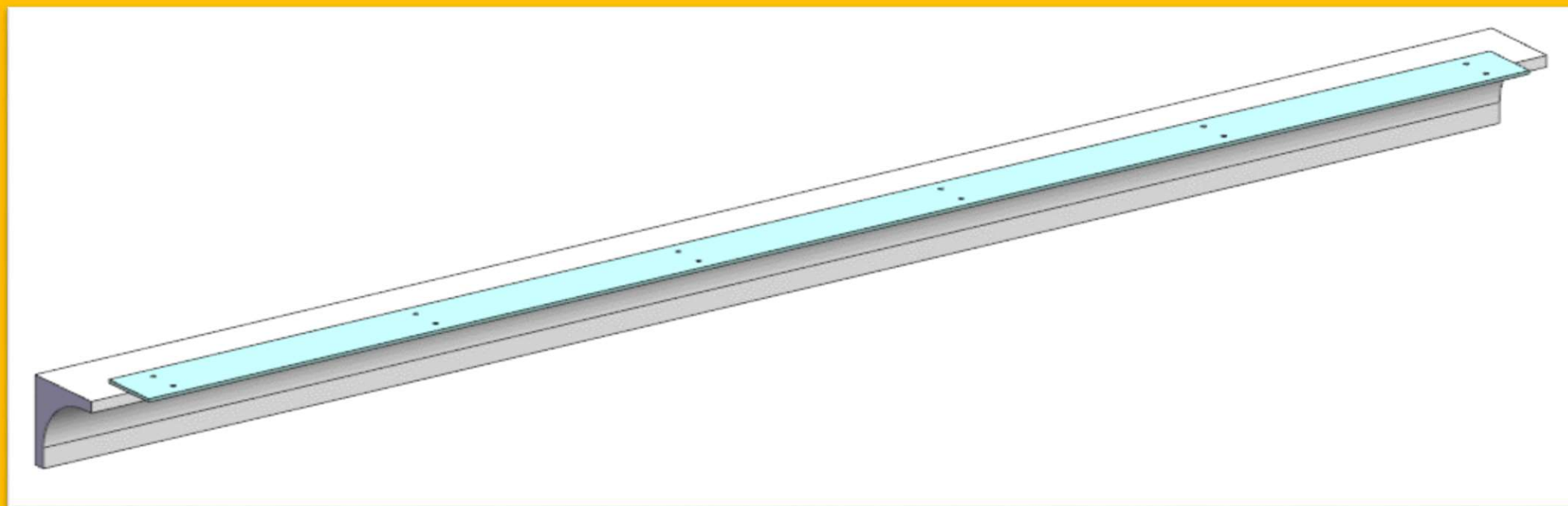

AZ26M

REV. GR 9

| LOCALE | CODICE | DESCRIZIONE COMPONENTE | FINITURA | Q.TA | OPERATORE |
|--------|------------|--|----------|------|-----------|
| CUCINA | AZ26M-KY01 | STRUTTURA CIELINO SOPRA PENSILE POPPA | GREZZO | 2 | Damiano |

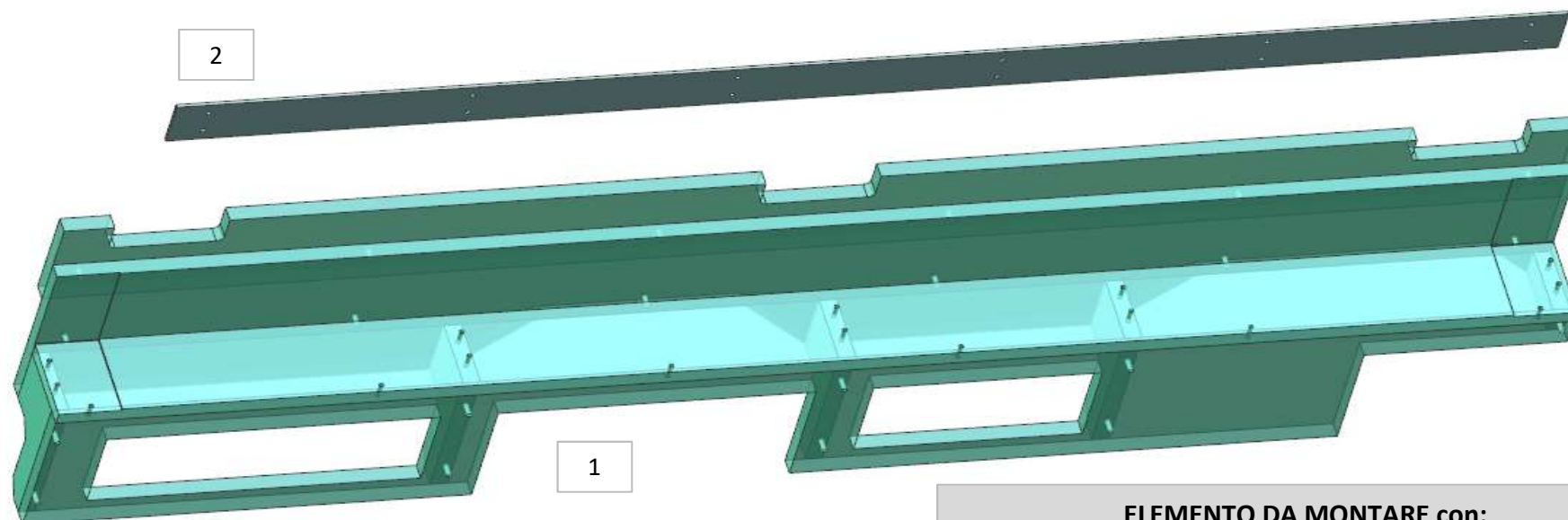

ELEMENTO DA MONTARE con:
L01_KY01
spedire con un unico imballo

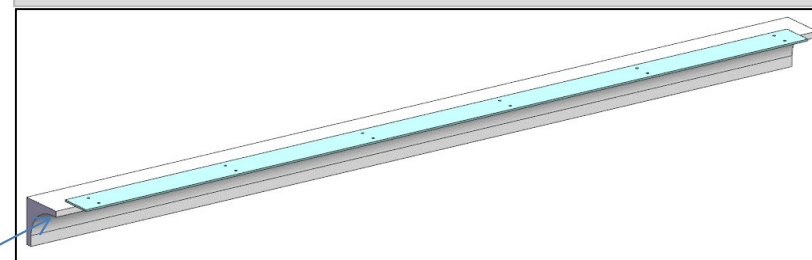

L01_KY01

AZ26M

REV. GR 9

| LOCALE | CODICE | DESCRIZIONE COMPONENTE | FINITURA | Q.TA | OPERATORE |
|--------|----------------|--------------------------------------|-------------------------|------|-----------|
| CUCINA | AZ26M-L01_KY01 | STRUTTURA CIELINO SOPRA PENSILE PRUA | LACCATO BIANCO RAL 9016 | 1 | Damiano |

1 - L. 1276 x H.78 x 70

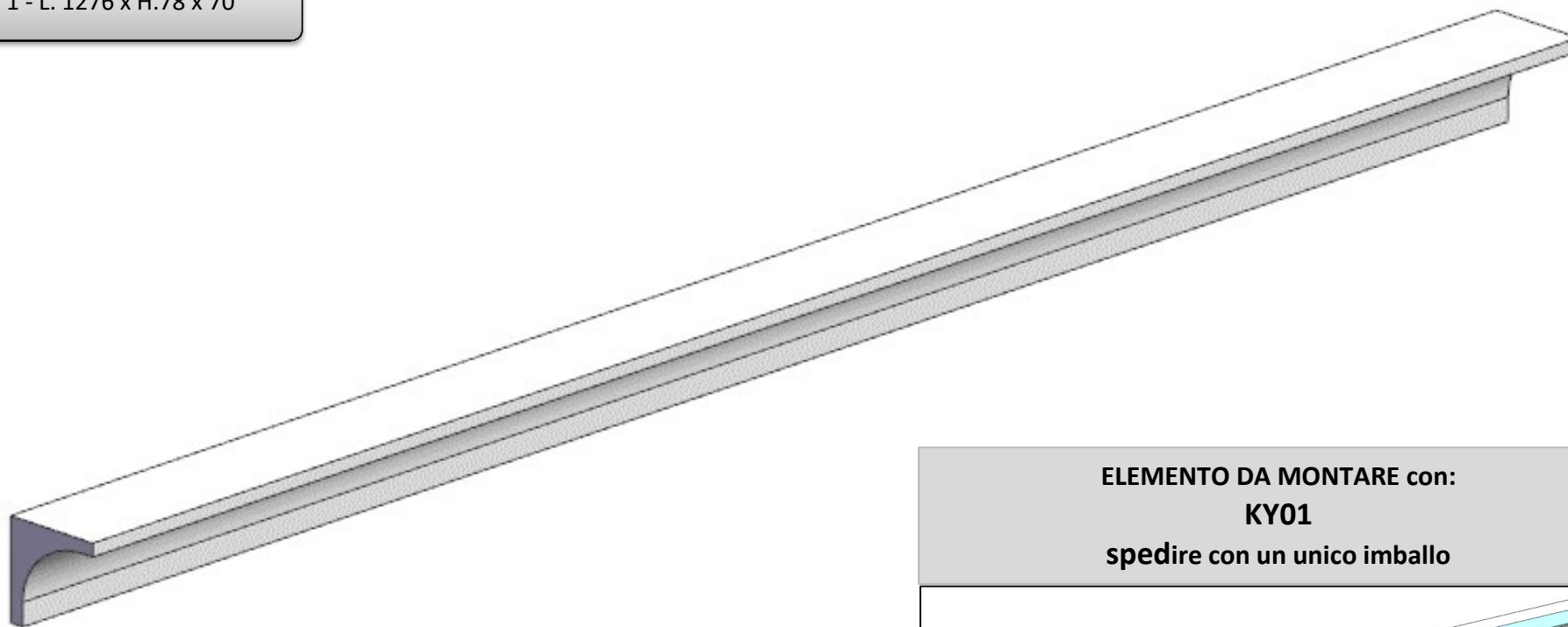

ELEMENTO DA MONTARE con:
KY01
spedire con un unico imballo

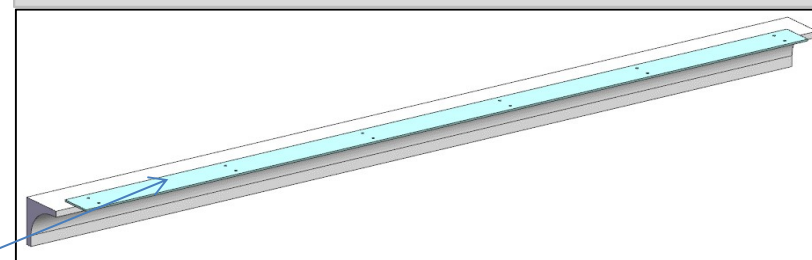

KY01

consonni&c

AZ26M

REV. GR 9

| LOCALE | CODICE | DESCRIZIONE COMPONENTE | FINITURA | Q.TA | OPERATORE |
|--------|----------------|--------------------------------|-------------------------|------|-----------|
| CUCINA | AZ26M-L01_KZ01 | STRUTTURA CIELINO ZONA CAMBUSA | LACCATO BIANCO RAL 9016 | 2 | Damiano |

1 - L. 698 x H 648 x sp 10
2- L. 649 x H 702 x sp 10

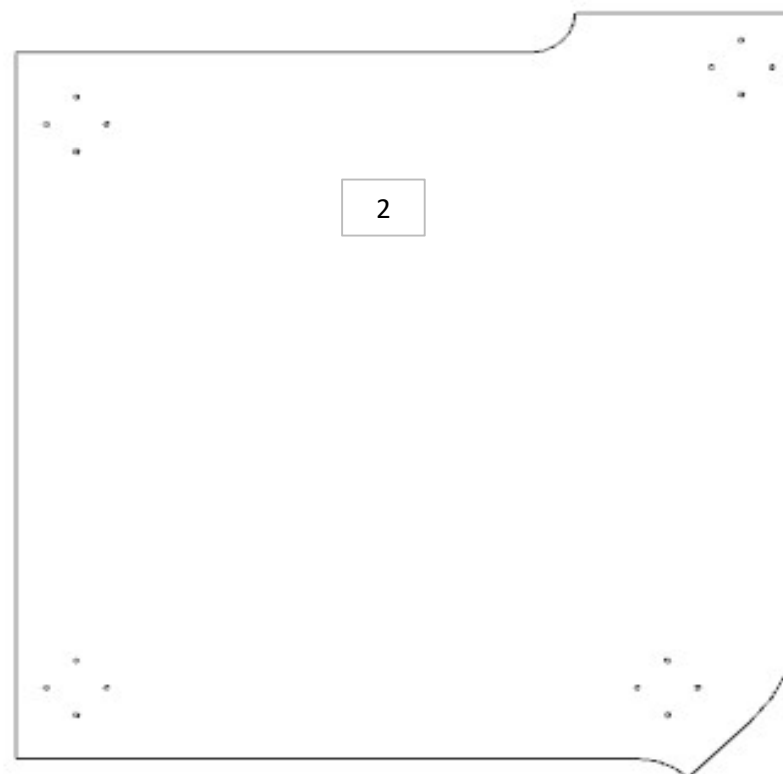
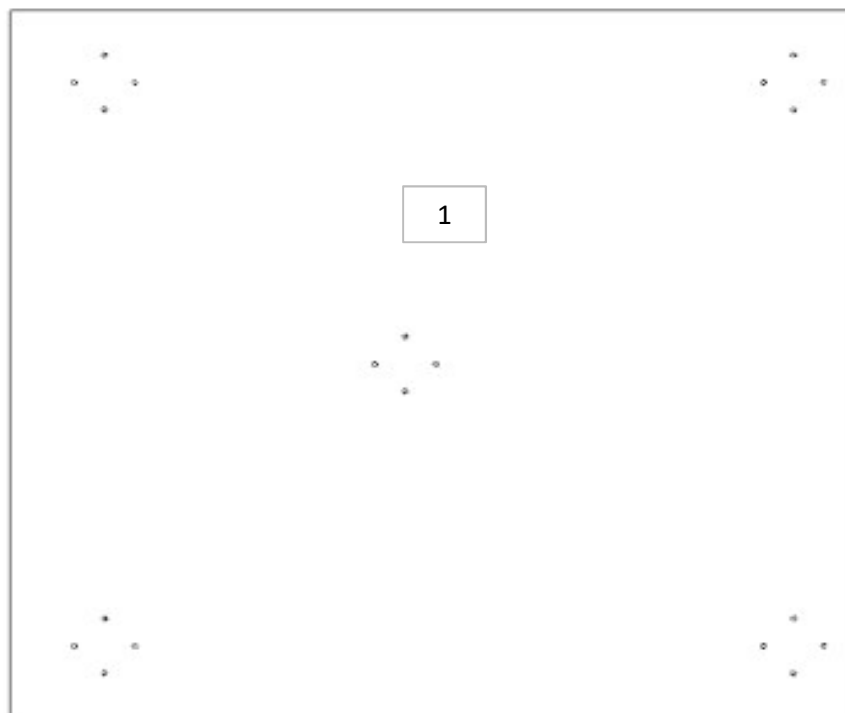

AZ26M

REV. GR 9

| LOCALE | CODICE | DESCRIZIONE COMPONENTE | FINITURA | Q.TA | OPERATORE |
|--------------|---------------|-------------------------|----------|------|-----------|
| DAILY TOILET | AZ26M-MG_DF01 | NICCHIA LATERALE LAVABO | | | Damiano |

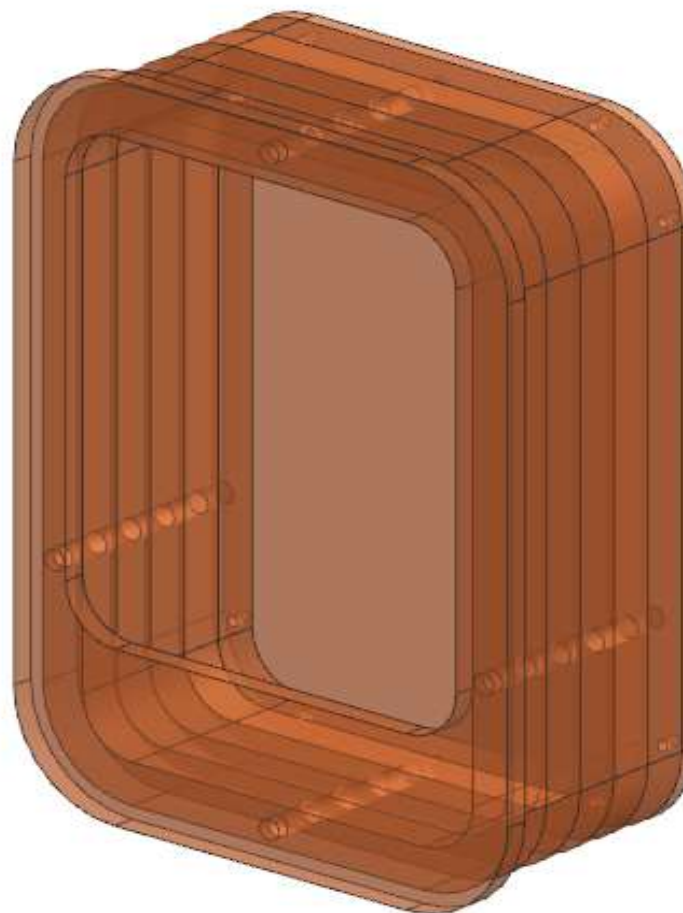

FERRAMENTA:

N° 4 - SPINA diam 8

AZ26M

REV. GR 9

| LOCALE | CODICE | DESCRIZIONE COMPONENTE | FINITURA | Q.TA | OPERATORE |
|--------------|----------------|-------------------------|----------------|------|-----------|
| DAILY TOILET | AZ26M-L01_DF01 | NICCHIA LATERALE LAVABO | LACCATO BRONZO | 3 | Damiano |

- 1 - L. 200 x H.275 x sp 8
- 2 - L. 190 x H.265 x sp 80
- 3 - L. 190 x H.265 x sp 6

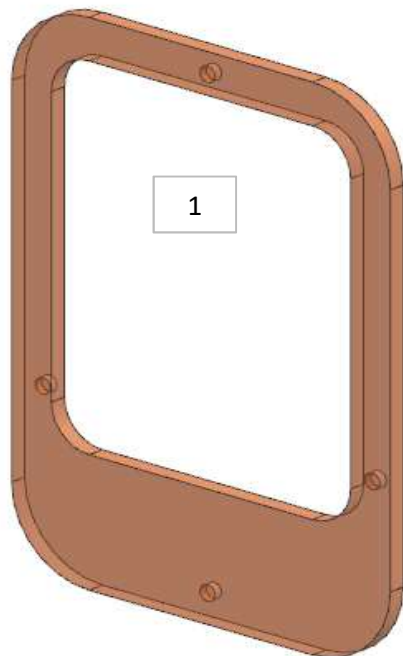

1

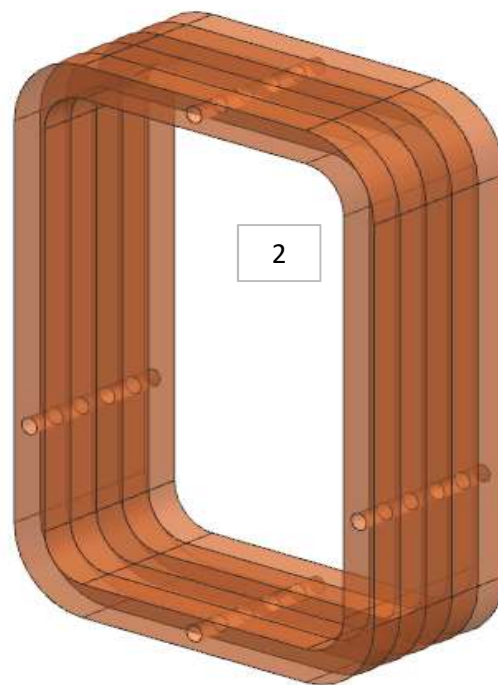

2

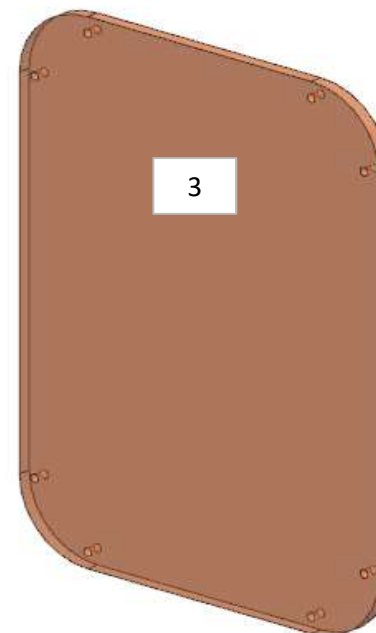

3

ELEMENTO DA MONTARE
con:
MG_DF01
e spedire con un unico
imballo

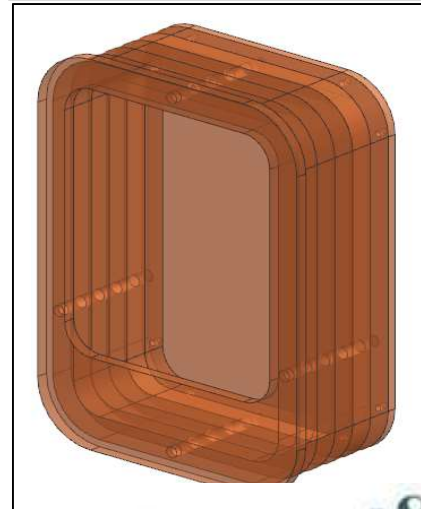

FERRAMENTA:
N° 4 - SPINA diam 8

AZ26M

REV. GR 9

| LOCALE | CODICE | DESCRIZIONE COMPONENTE | FINITURA | Q.TA | OPERATORE |
|--------------|----------------|------------------------|----------------------------|------|-----------|
| DAILY TOILET | AZ26M-L01_DH01 | CIELINO | LACCATO BIANCO RAL 9016 | 1 | Damiano |

1 - L.1223 x H 675 x sp 10



consonni&c

AZ26M

DA GR5

REV. GR 9

| LOCALE | CODICE | DESCRIZIONE COMPONENTE | FINITURA | Q.TA | OPERATORE |
|--------------|------------|------------------------|----------------|------|-----------|
| DAILY TOILET | AZ26M-DI01 | RIVESTIMENTO LAVELLO | OKOUME' GREZZO | 3 | Damiano |

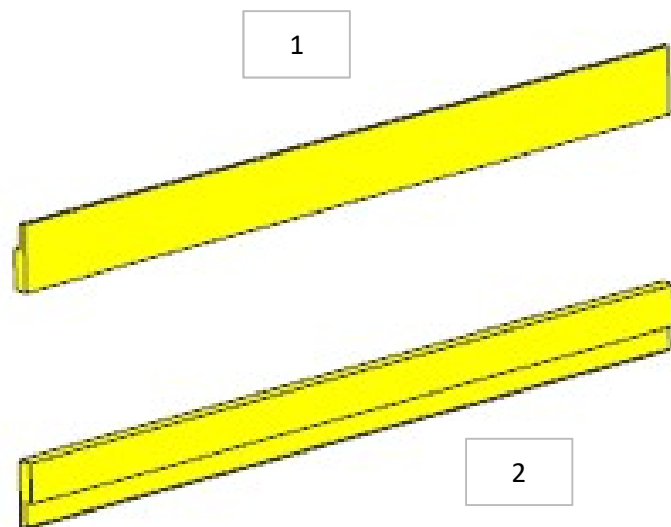

1 - 2 - L 521 x H 50 x sp 10
3 - L 150 x H 132 x sp 14

**DA MAT 21
TUTTO MODIFICATO - ADESSO 3
PEZZI GREZZI
1 PZ LACCATO BIANCO 9010
3 PEZZI LAMINATO NERO**

AZ26M

DA GR5

REV. GR 9

| LOCALE | CODICE | DESCRIZIONE COMPONENTE | FINITURA | Q.TA | OPERATORE |
|--------------|-------------------|------------------------|-------------------------|------|-----------|
| DAILY TOILET | AZ26M-L01_DI01_01 | RIVESTIMENTO LAVELLO | LACCATO BIANCO RAL 9010 | 1 | Damiano |

1 - L.975 x H 302 x sp 689

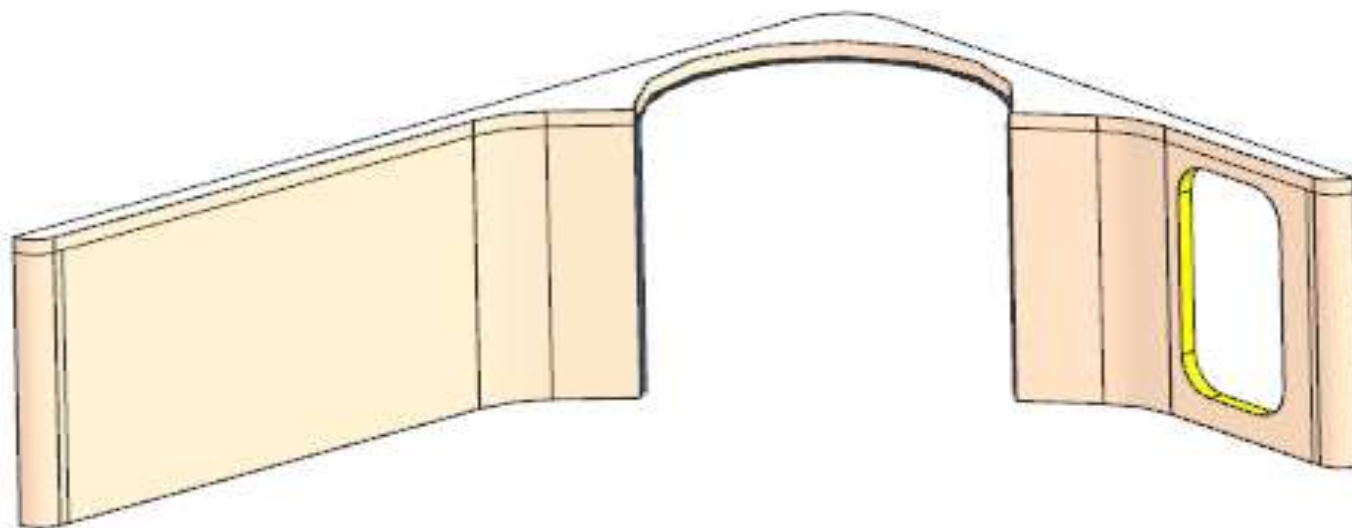

AZ26M

DA GR5

REV. GR 9

| LOCALE | CODICE | DESCRIZIONE COMPONENTE | FINITURA | Q.TA | OPERATORE |
|--------------|-----------------|------------------------|---------------|------|-----------|
| DAILY TOILET | AZ26M-X01_DI01_ | RIVESTIMENTO LAVELLO | LAMINATO NERO | 3 | Damiano |

- 1 - L.30 x H 283 x sp 3
- 2 - L.386 x H 164 x sp 3
- 3 - L.30 x H 283 x sp 3

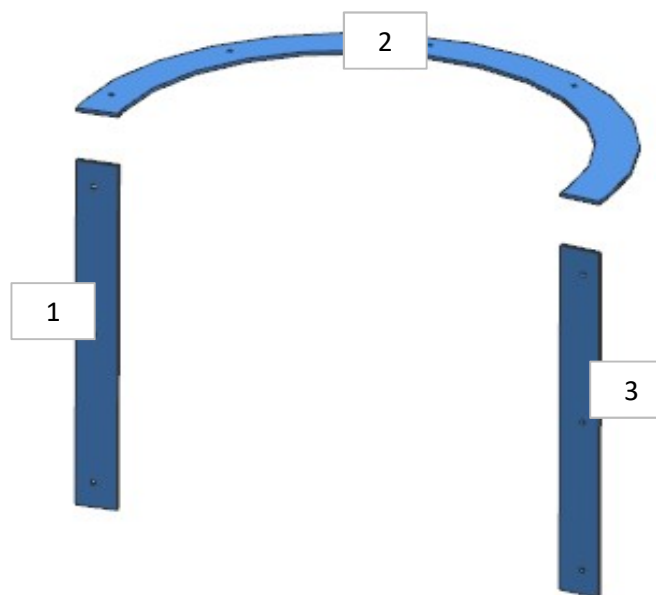

AZ26M

REV. GR 9

| LOCALE | CODICE | DESCRIZIONE COMPONENTE | FINITURA | Q.TA | OPERATORE |
|--------------|----------------|------------------------|----------------------|------|-----------|
| DAILY TOILET | AZ26M-R01_DL01 | PAVIMENTO BAGNO IROKO | IROKO DOGATO\ GREZZO | 2 | Damiano |

- 1 - L.376 x H 1283 x sp 16
- 2 - L.418 x H 1283 x sp 16

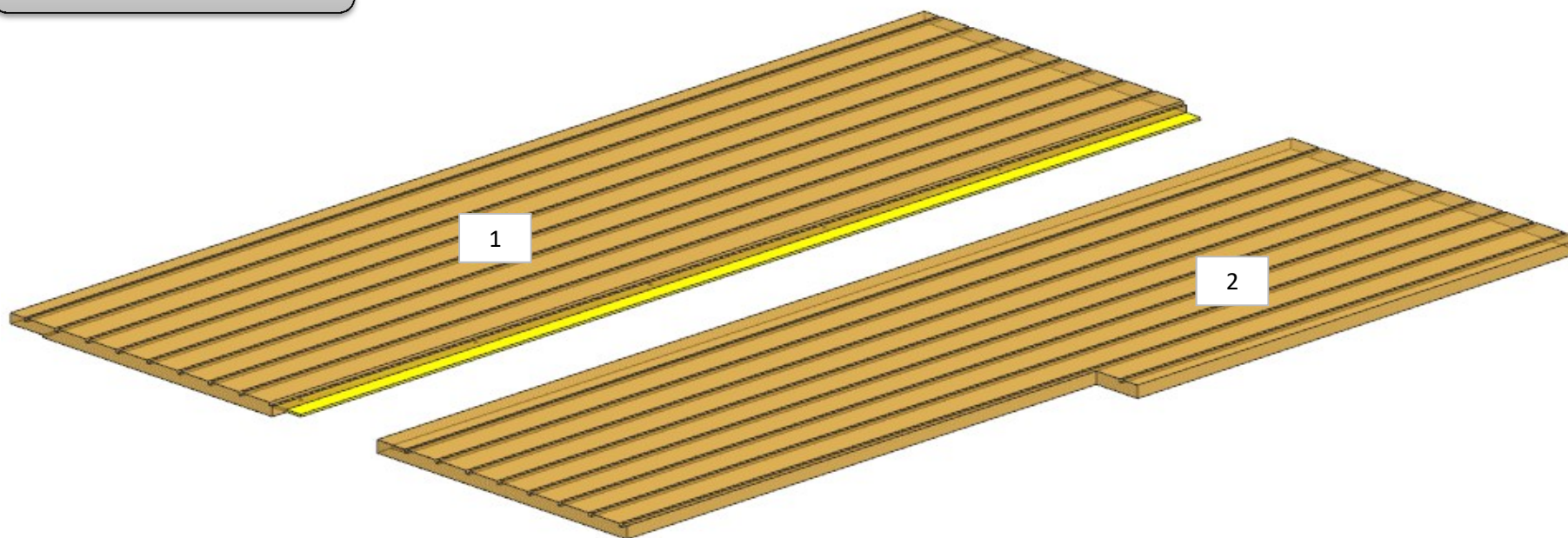

AZ26M

REV. GR 9

| LOCALE | CODICE | DESCRIZIONE COMPONENTE | FINITURA | Q.TA | OPERATORE |
|-----------|----------------|------------------------|----------------|------|-----------|
| TIMONERIA | AZ26M-L01_TN01 | RIV. PARETE TIENTIBENE | LACCATO BRONZO | 1 | Damiano |

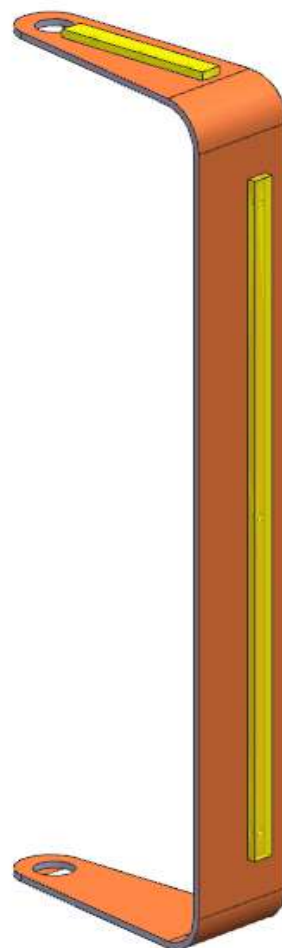

AZ26M

REV. GR 9

| LOCALE | CODICE | DESCRIZIONE COMPONENTE | FINITURA | Q.TA | OPERATORE |
|-----------|----------------|------------------------|----------|------|-----------|
| TIMONERIA | AZ26M-A01_TN01 | RIV. PARETE TIENTIBENE | ACCIAIO | 3 | Damiano |

1 - 2 - L 40 x H 73 x 30
3 - DIAM 37 H. 1003



3

DETTAGLIO

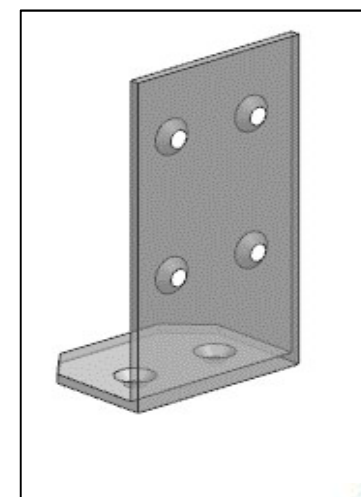

consonni&c

AZ26M

REV. GR 9

| LOCALE | CODICE | DESCRIZIONE COMPONENTE | FINITURA | Q.TA | OPERATORE |
|-----------|----------------|------------------------------|-------------------------|------|-----------|
| TIMONERIA | AZ26M-L01_TP01 | CIELINO A L DISCESA MARINAIO | LACCATO BIANCO RAL 9016 | 2 | Damiano |

- 1 - L 633 x H.322 x sp 10
- 2 - L 633 x H.681 x sp 10

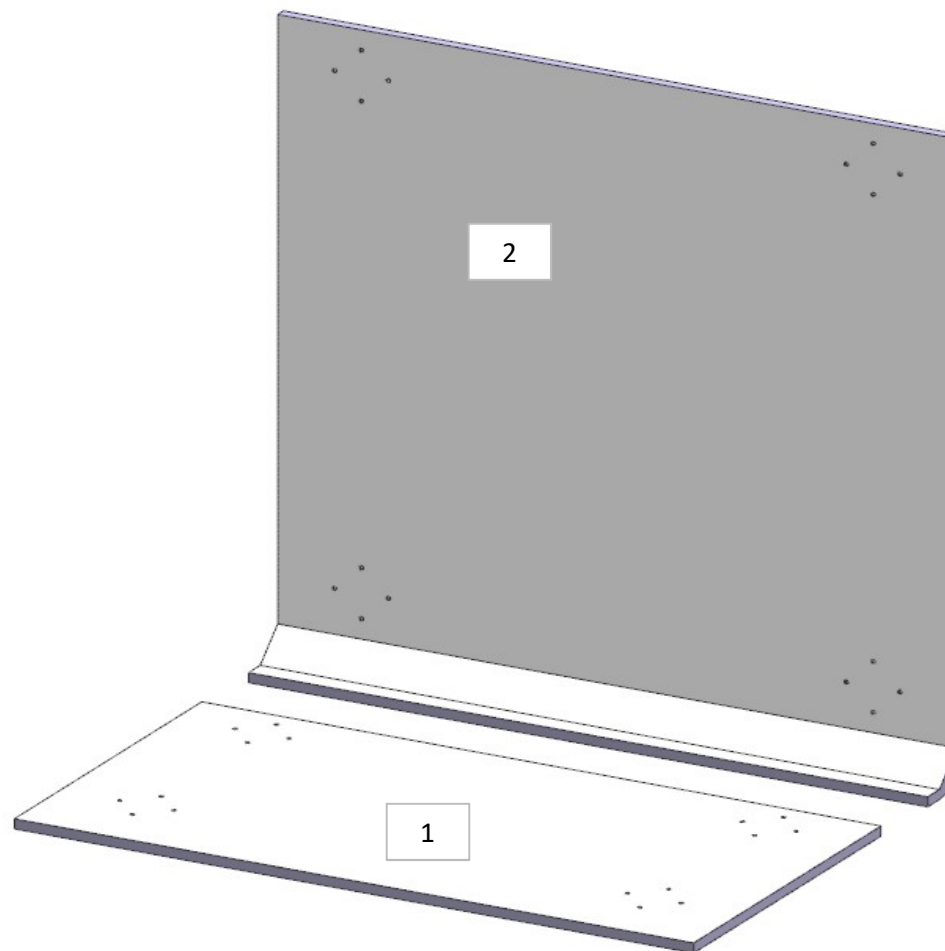

AZ26M

MOD GR4

REV. GR 9

| LOCALE | CODICE | DESCRIZIONE COMPONENTE | FINITURA | Q.TA | OPERATORE |
|--------|----------------|-----------------------------|---------------|------|-----------|
| SALONE | AZ26M-R01_TQ01 | MOBILETTO ALLARMI TIMONERIA | LASTRA CHIARA | 1 | Damiano |

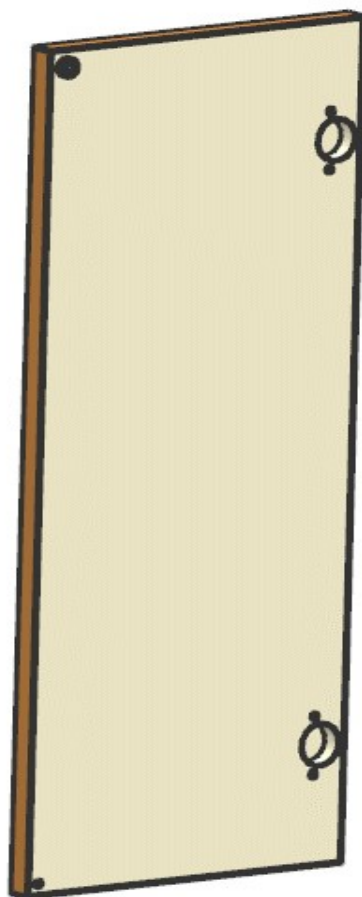

1 - L.290 x H 701 x sp 11

MOD AZ 167
aggiunto storage:
a mano da GR1
di serie da GR 4

AZ26M

REV. GR 9

| LOCALE | CODICE | DESCRIZIONE COMPONENTE | FINITURA | Q.TA | OPERATORE |
|-----------|----------------|----------------------------------|----------------|------|-----------|
| TIMONERIA | AZ26M-L01_TT01 | PLENUM SOPRA OBLO' DISCESA SCALE | LACCATO BRONZO | 1 | Damiano |

1 - L 594 x H.106 x sp 16



AZ26M

REV. GR 9

| LOCALE | CODICE | DESCRIZIONE COMPONENTE | FINITURA | Q.TA | OPERATORE |
|-----------|----------------|--|---------------|------|-----------|
| TIMONERIA | AZ26M-R01_TU01 | BLOCCO CENTRALE CRUSCOTTO TIMONERIA | LASTRA CHIARA | 2 | Damiano |

1 - L 845 x H 838 x sp 11
2 - L 545 x H 838 x sp 11

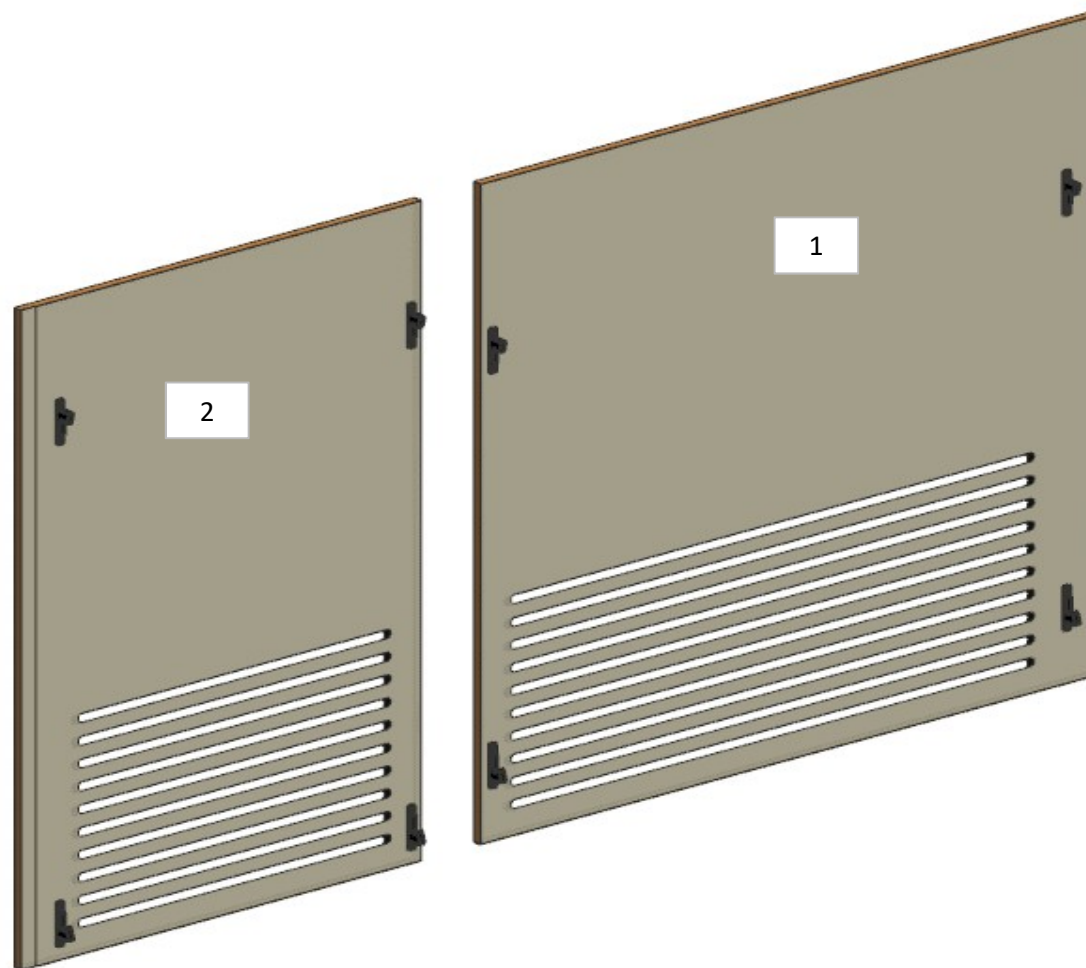

consonni&c

AZ26M

MOD GR4

REV. GR 9

| LOCALE | CODICE | DESCRIZIONE COMPONENTE | FINITURA | Q.TA | OPERATORE |
|-----------|----------------|-------------------------------|---------------|------|-----------|
| TIMONERIA | AZ26M-R01_TX01 | RIV. GRADINI DISCESA MARINAIO | LASTRA CHIARA | 19 | Damiano |

eliminato MF

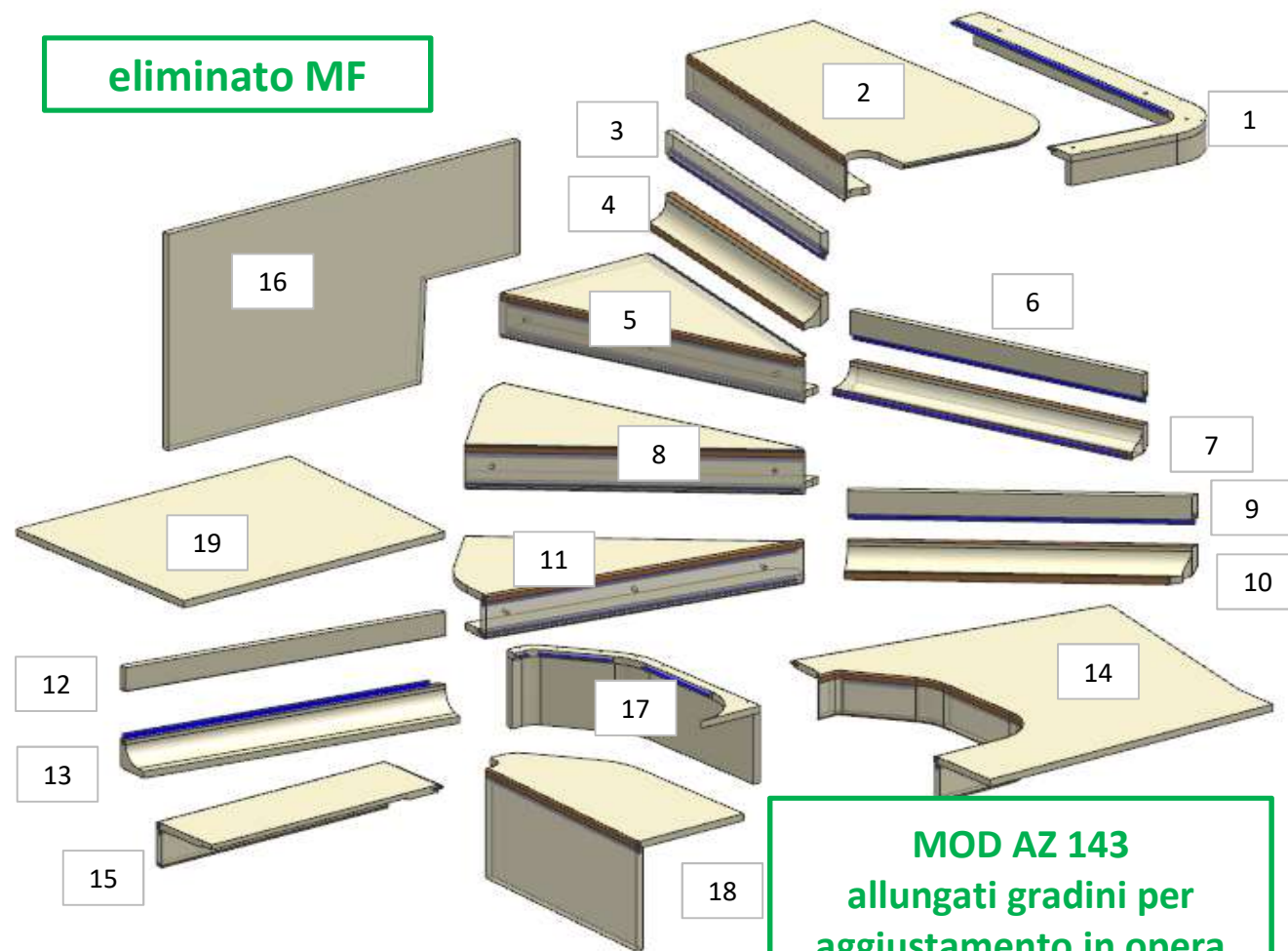

- 1 - sviluppo L 1074 x H.69 x 60
- 2 - L. 786 x H.100 x 435
- 3 - L. 687 x H.50 x sp 16
- 4 - L. 679 x H.70 x 57

- 5 - L. 716 x H.100 x 358
- 6 - L. 707 x H.54 x sp 16
- 7 - L. 719 x H.66 x 57
- 8 - L. 712 x H.100 x 371
- 9 - L. 712 x H.54 x sp 16
- 10 - L. 717 x H.66 x 66
- 11 - L. 735 x H.100 x 312
- 12 - L. 730 x H.54 x sp 16
- 13 - L. 730 x H.66 x 75
- 14 - L. 642 x H.100 x 703
- 15 - L. 542 x H.100 x 168
- 16 - L. 843 x H.488 x sp 16
- 17 - sviluppo L 627 x H.174 x 208
- 18 - L. 540 x H 246 x 257
- 19 - L. 657 x H.535 x sp 16

MOD AZ 143
allungati gradini per
aggiustamento in opera

AZ26M

MOD GR4

REV. GR 9

| LOCALE | CODICE | DESCRIZIONE COMPONENTE | FINITURA | Q.TA | OPERATORE |
|-----------|----------------|-------------------------------|----------------|------|-----------|
| TIMONERIA | AZ26M-L01_TX01 | RIV. GRADINI DISCESA MARINAIO | LACCATO OTTONE | 3 | Damiano |

- 1 - L.745 x H 97 x 342
- 2 - L.451 x H 30 x sp 16
- 3 - L.1479 x H 30 x sp 16

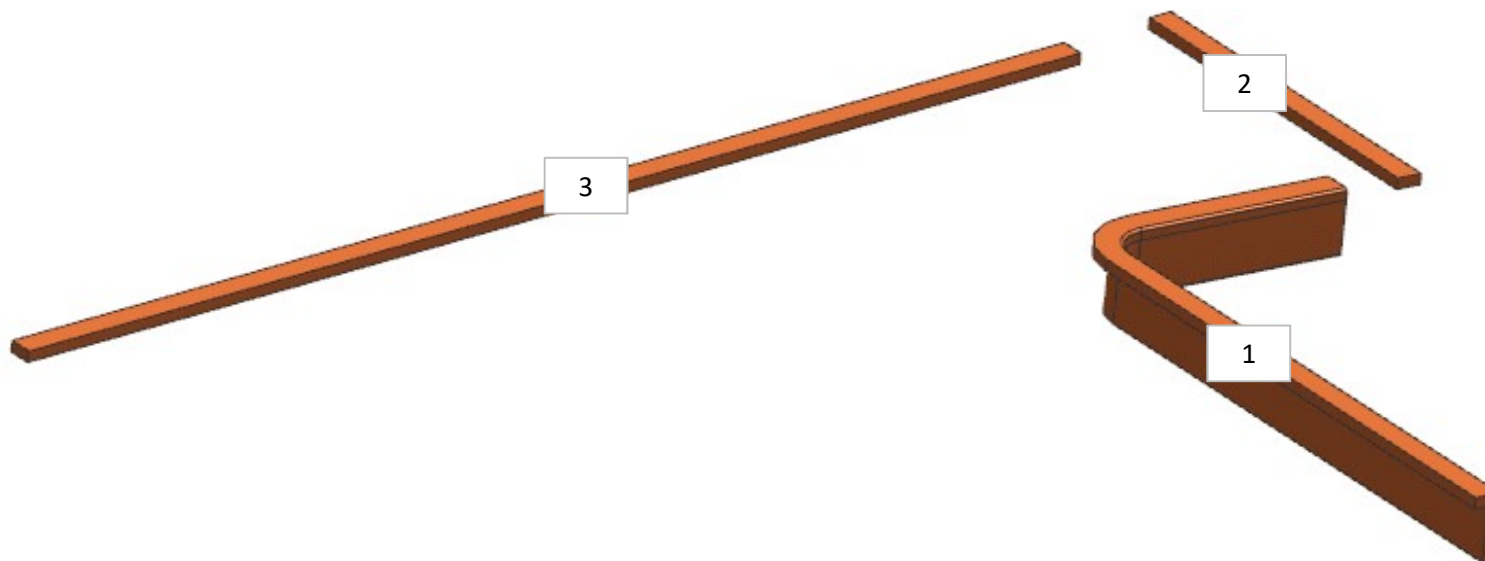

AZ26M

MOD GR4

REV. GR 9

| LOCALE | CODICE | DESCRIZIONE COMPONENTE | FINITURA | Q.TA | OPERATORE |
|-----------|----------------|-------------------------------|---------------|------|-----------|
| TIMONERIA | AZ26M-R01_TY01 | RIV. GRADINI DISCESA ARMATORE | LASTRA CHIARA | 13 | Damiano |

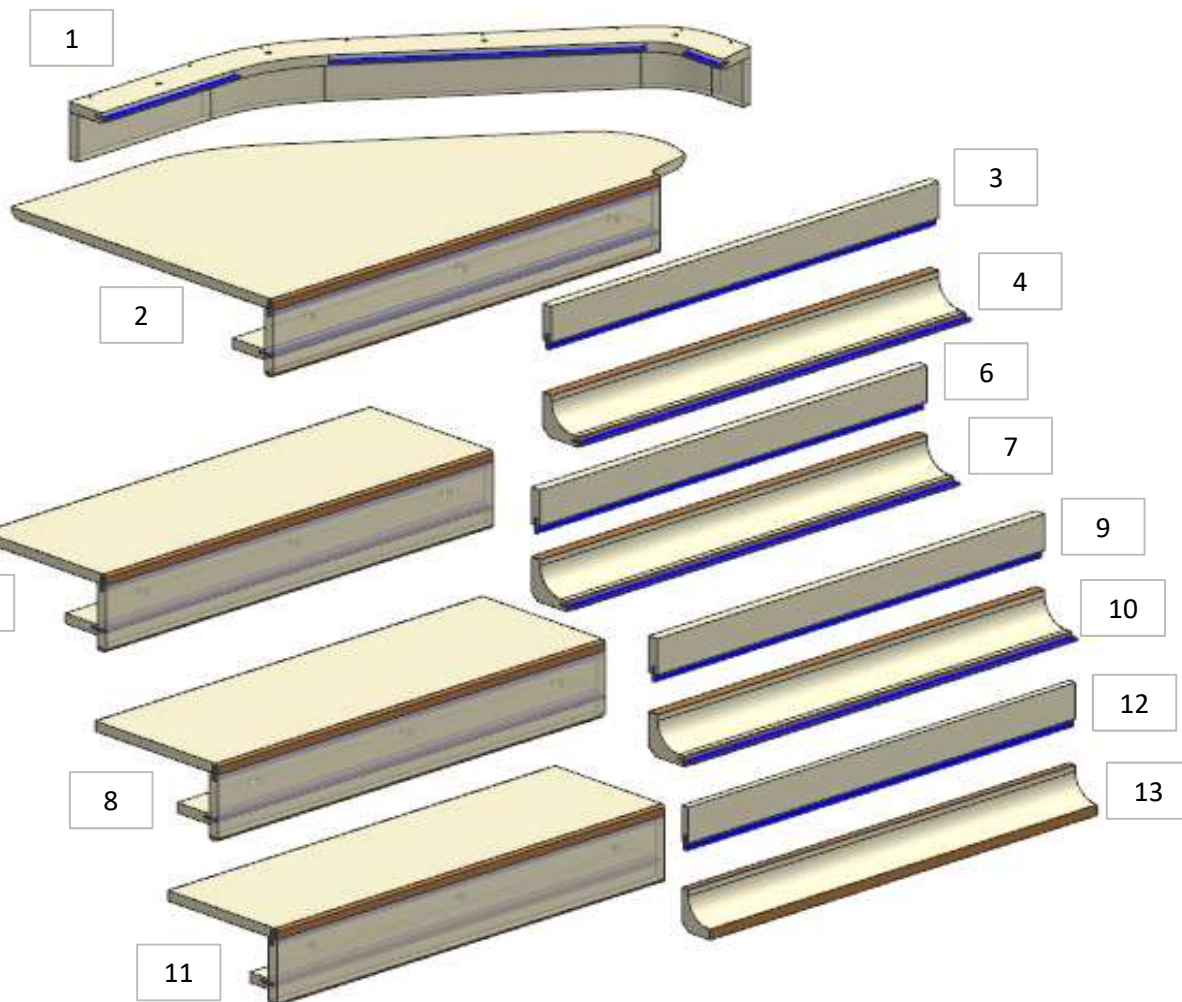

- 1 - L 937 x H 89 x 258
- 2 - L 806 x H 120 x 490
- 3 - 6 - 9 - 12 - L 739 x H 57 x sp 16
- 4 - 7 - 10 - L 739 x H 66 x 66
- 5 - 8 - 11 - L 739 x H 120 x 228
- 13 - L 739 x H 66 x 52

MOD AZ 144
allungati gradini per
aggiustamento in opera

eliminato MF

AZ26M

MOD GR4

REV. GR 9

| LOCALE | CODICE | DESCRIZIONE COMPONENTE | FINITURA | Q.TA | OPERATORE |
|-----------|----------------|-------------------------------|----------------|------|-----------|
| TIMONERIA | AZ26M-L01_TY01 | RIV. GRADINI DISCESA ARMATORE | LACCATO OTTONE | 3 | Damiano |

- 1 - SVILUPPO L 879 x H.100 x 71
- 2 - SVILUPPO L 436 x H.16 x 30
- 3 - L.1439 x H.42 x sp16

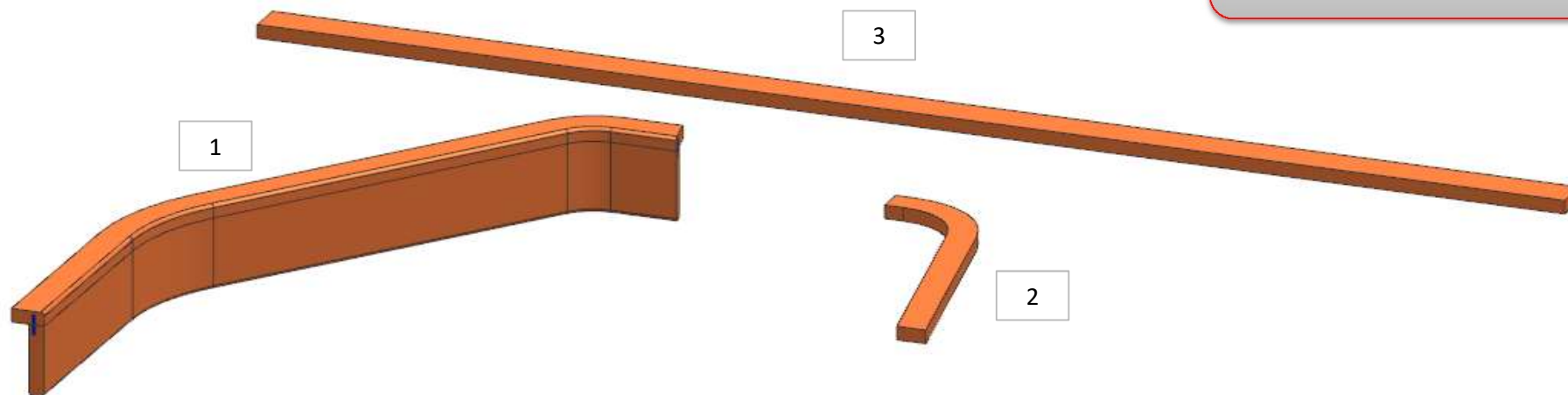

AZ26M

MOD DA GR9

REV. GR 9

| LOCALE | CODICE | DESCRIZIONE COMPONENTE | FINITURA | Q.TA | OPERATORE |
|----------|--------------------|---------------------------------|----------------|------|-----------|
| LOBBY MD | AZ26M_L01_CCD01_01 | STRUTTURA SUPERIORE MOBILE RACK | LACCATO BRONZO | 1 | Damiano |

1 - L 1107 x H.92 x sp 16

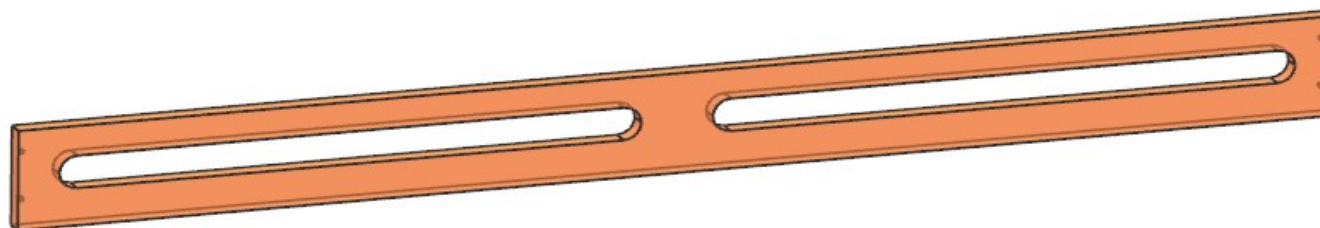

FERRAMENTA:

- N° 6 - FITLOCK MASCHIO
- N° 6 - FITLOCK FEMMINA
- N° 4 - SPINA diam 8
- N° 2 - BUSSOLA ZAMA 6MA
- N° 8 - VITI 6MA
- N° 2 - SOUTCHO

MOD AZ 264
FATTO ASOLATURA SUL
PANNELLO IN ESSENZ PER
EVITARE
SURRISCALDAMENTO AV

AZ26M

REV. GR 9

| LOCALE | CODICE | DESCRIZIONE COMPONENTE | FINITURA | Q.TA | OPERATORE |
|----------|-----------------|------------------------|---------------|------|-----------|
| LOBBY MD | AZ26M-R01_CCG01 | CIELINO | LASTRA CHIARA | 1 | Damiano |

1 - L 1088 x H 629 x sp 11

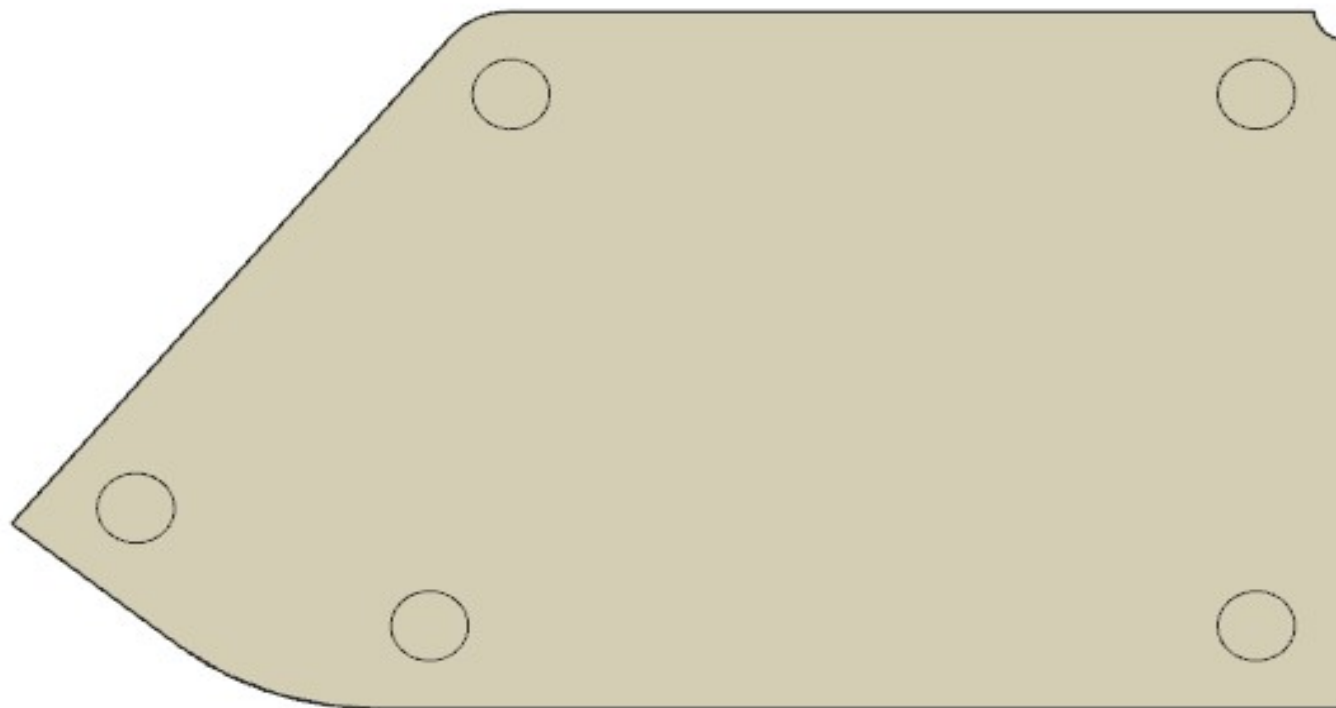

AZ26M

REV. GR 9

| LOCALE | CODICE | DESCRIZIONE COMPONENTE | FINITURA | Q.TA | OPERATORE |
|----------|-----------------|------------------------|---------------|------|-----------|
| LOBBY MD | AZ26M-R01_CCH01 | GRADINO | LASTRA CHIARA | 1 | Damiano |

1 - L 1147 x H 171 x sp 6

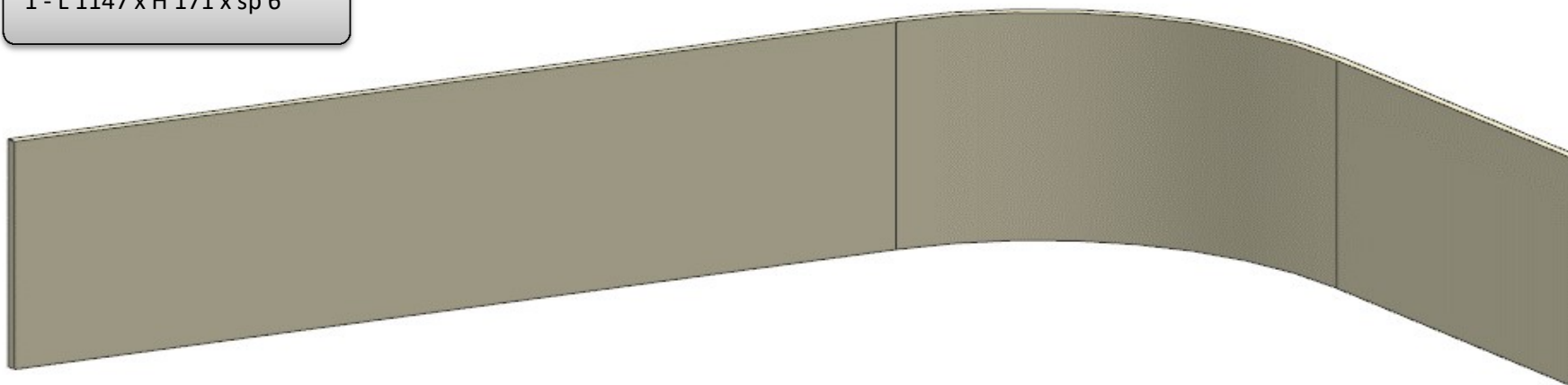

ELEMENTO DA MONTARE con:
CCH01
L01_CCH01
e spedire con un unico imballo

L01_CCH01

CCH01

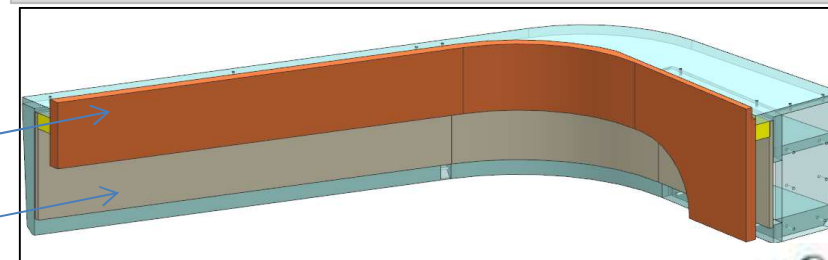

consonni&c

AZ26M

REV. GR 9

| LOCALE | CODICE | DESCRIZIONE COMPONENTE | FINITURA | Q.TA | OPERATORE |
|----------|-----------------|------------------------|----------------|------|-----------|
| LOBBY MD | AZ26M-L01_CCH01 | GRADINO | LACCATO BRONZO | 1 | Damiano |

1 - L 1075 x H 213 x sp 16

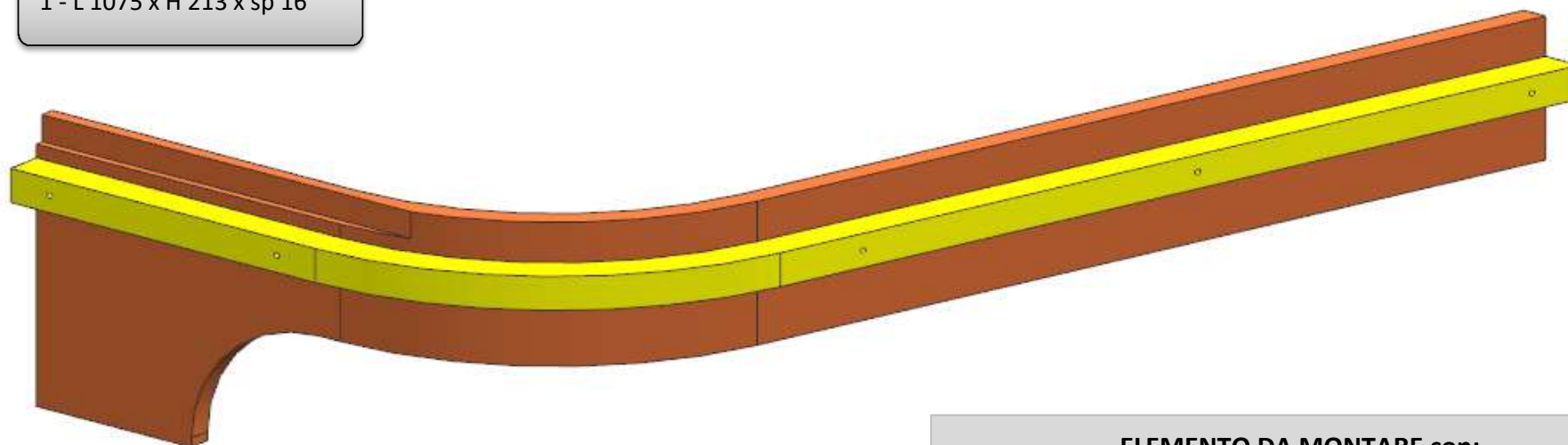

ELEMENTO DA MONTARE con:
R01_CCH01
CCH01
e spedire con un unico imballo

CCH01
R01_CCH01

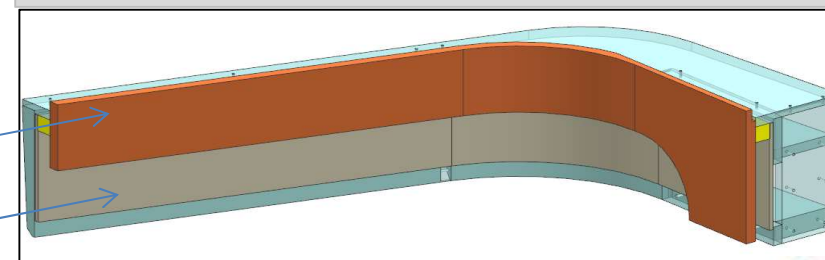

consonni&c

AZ26M

REV. GR 9

| LOCALE | CODICE | DESCRIZIONE COMPONENTE | FINITURA | Q.TA | OPERATORE |
|----------|-----------------|------------------------|---------------|------|-----------|
| LOBBY MD | AZ26M-R01_CCL01 | RIV. SOPRA PORTA | LASTRA CHIARA | 1 | Damiano |

1 - L 698 x H 78 x sp 11

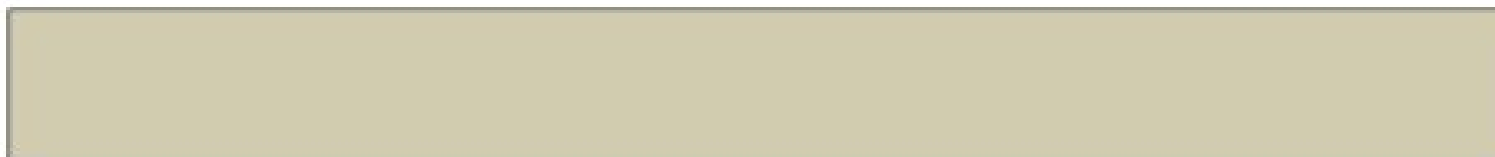

AZ26M

DA PTP

REV. GR 9

| LOCALE | CODICE | DESCRIZIONE COMPONENTE | FINITURA | Q.TA | OPERATORE |
|--------|---------------|------------------------|----------|------|-----------|
| SALONE | AZ26M-MF_SJ01 | TAVOLO SALONE | | 1 | Damiano |

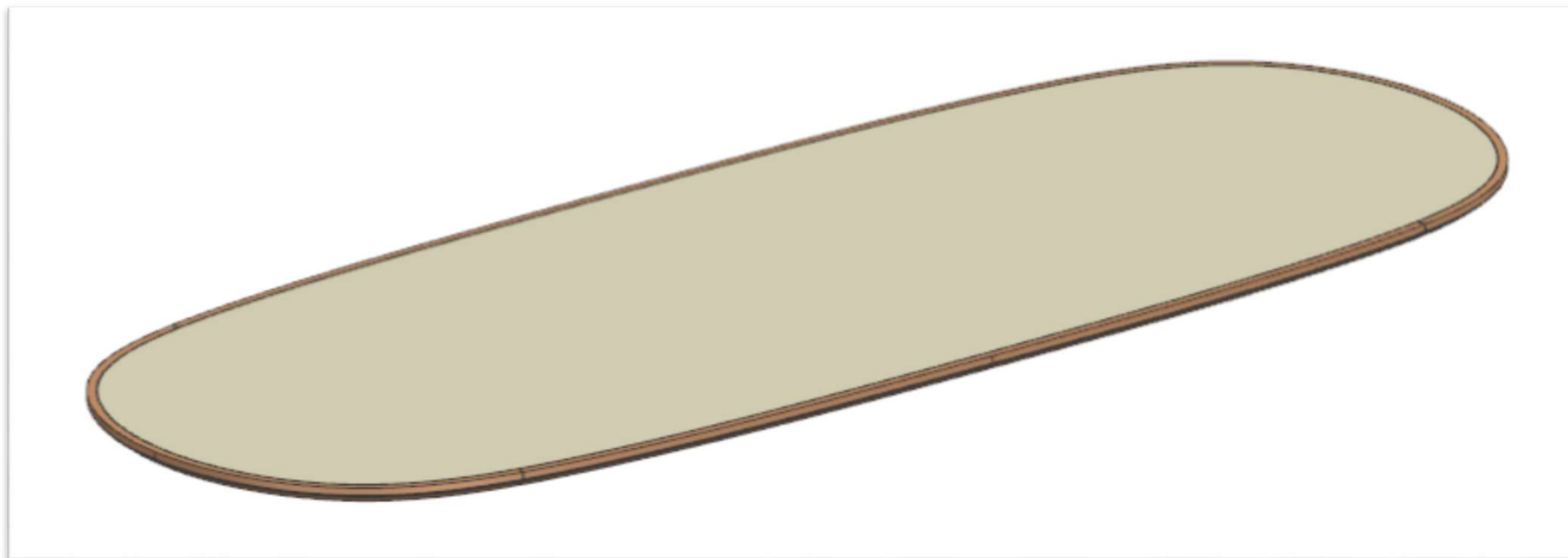

AZ26M

MOD DA PTP

REV. GR 9

| LOCALE | CODICE | DESCRIZIONE COMPONENTE | FINITURA | Q.TA | OPERATORE |
|--------|----------------|------------------------|---------------|------|-----------|
| SALONE | AZ26M-R01_SJ01 | TAVOLO SALONE | LASTRA CHIARA | 5 | Damiano |

MOD INT 38
 MODIFICATI CODICI
 LASTRA 02-03-04-05 E
 MODIFICATO PIASTRE

- 1 - L 2550 x H.950 x sp 32
- 2 - 3 - L 450 x H.695 x sp 77
- 4 - 5 - L 519 x H.695 x sp 77

MOD INT 38
 n°5 pz DA R01_SJ01_01
 DIVENTATI LACCATI

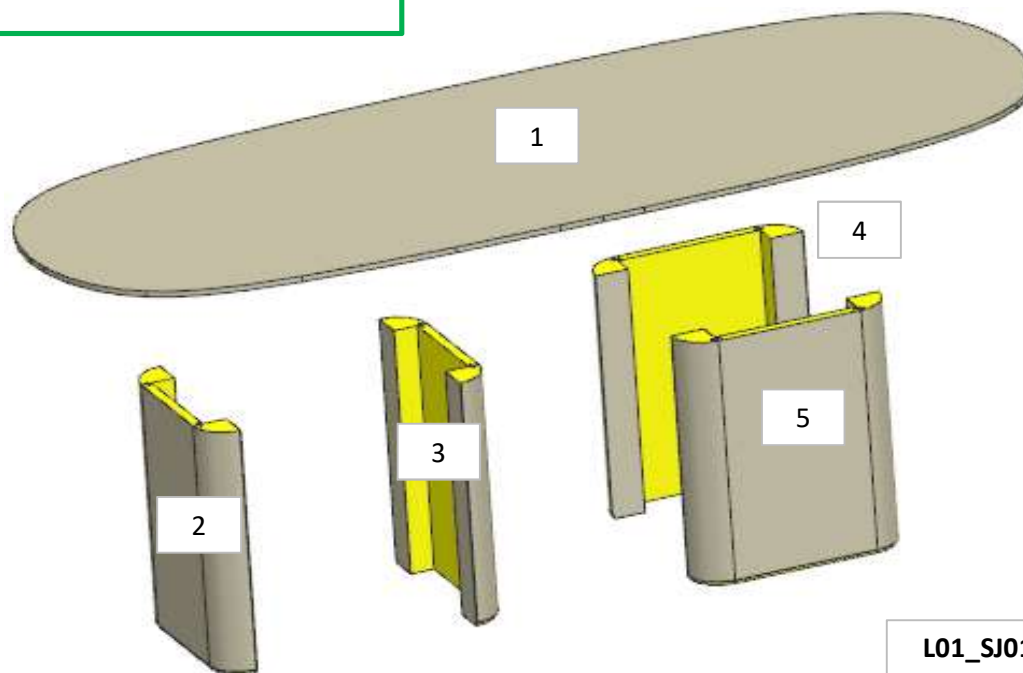

ELEMENTO DA MONTARE con:
L01_SJ01
 e spedire con un unico imballo

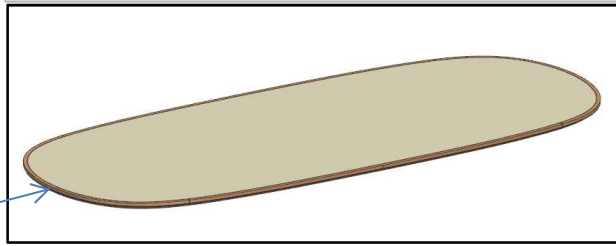

L01_SJ01

AZ26M

DA PTP

REV. GR 9

| LOCALE | CODICE | DESCRIZIONE COMPONENTE | FINITURA | Q.TA | OPERATORE |
|--------|----------------|------------------------|----------------|------|-----------|
| SALONE | AZ26M-L01_SJ01 | TAVOLO SALONE | LACCATO SABBIA | 5 | Damiano |

MOD INT 38
n°5 pz DA L01_SJ01_01
DIVENTATI LACCATI

1 - 3 L 1787 x H.47 x sp 32
2 - 4 L 859 x H.189 x sp 32
5 - L 2478 x H.473 x sp 32

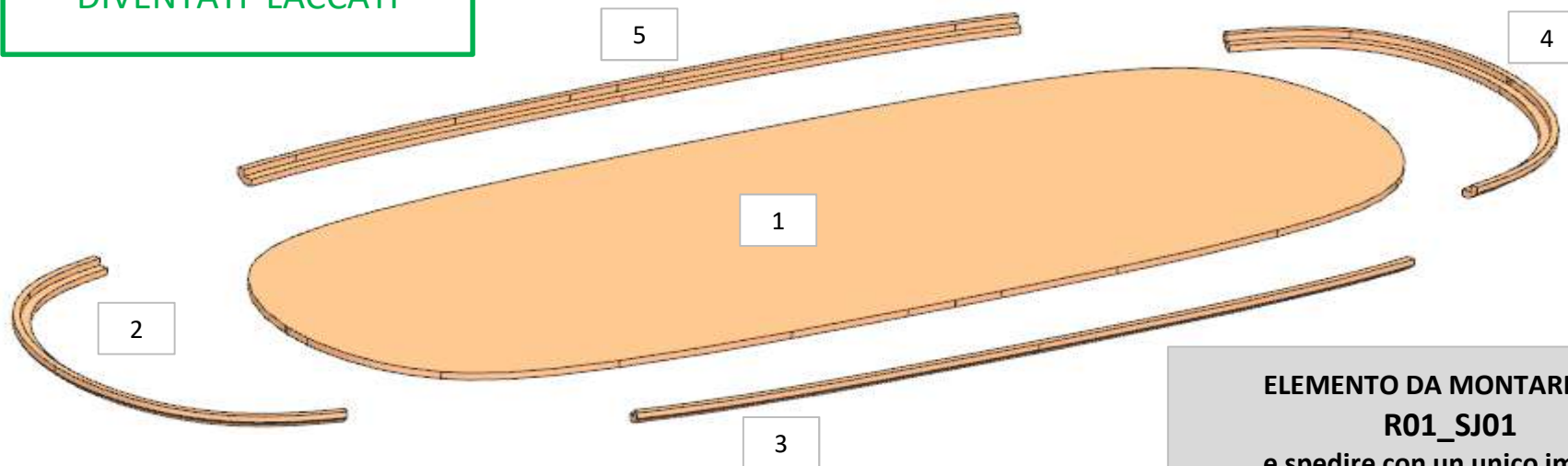

ELEMENTO DA MONTARE con:
R01_SJ01
e spedire con un unico imballo

R01_SJ01

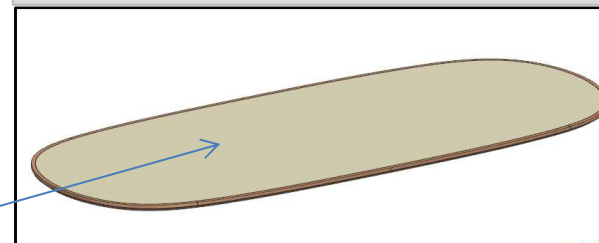

consonni&c

AZ26M

REV. GR 9

| LOCALE | CODICE | DESCRIZIONE COMPONENTE | FINITURA | Q.TA | OPERATORE |
|--------|---------------|------------------------|------------------------|------|-----------|
| SALONE | AZ26M-MF_SK01 | COFFEE TABLE | LACCATO NCS S3020-Y30R | 1 | Damiano |



consonni&c

AZ26M

REV. GR 9

| LOCALE | CODICE | DESCRIZIONE COMPONENTE | FINITURA | Q.TA | OPERATORE |
|--------|----------------|------------------------|------------------------|------|-----------|
| SALONE | AZ26M-L01_SK01 | COFFEE TABLE | LACCATO NCS S3020-Y30R | 2 | Damiano |

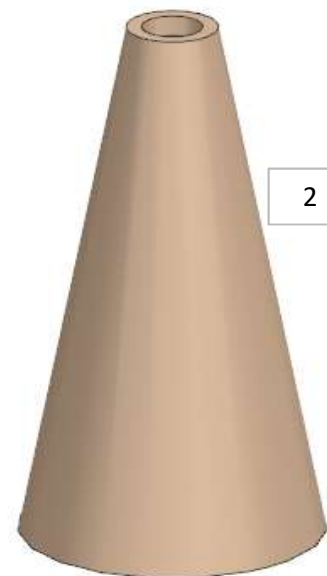
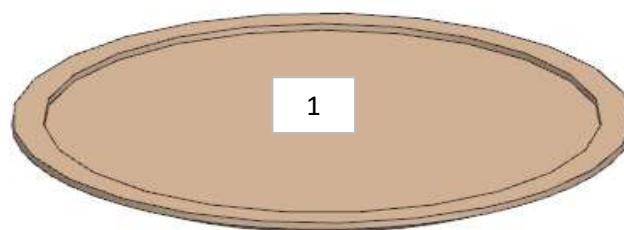

**ELEMENTO DA MONTARE con:
A01_SK01
e spedire con un unico imballo**

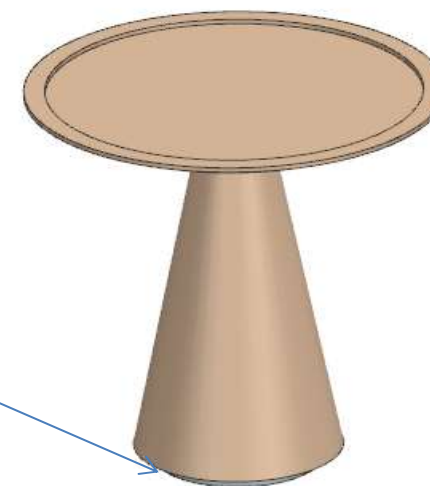

A01_SK01

consonni&c

AZ26M

REV. GR 9

| LOCALE | CODICE | DESCRIZIONE COMPONENTE | FINITURA | Q.TA | OPERATORE |
|--------|----------------|------------------------|----------|------|-----------|
| SALONE | AZ26M-A01_SK01 | COFFEE TABLE | ACCIAIO | 2 | Damiano |

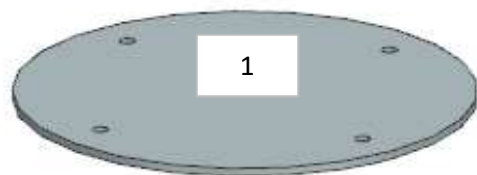

ELEMENTO DA MONTARE con:
L01_SK01
e spedire con un unico imballo

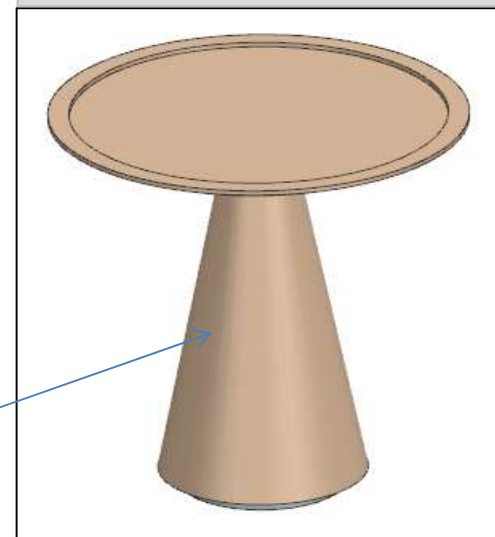

AZ26M

MOD DA GR4

REV. GR 9

| LOCALE | CODICE | DESCRIZIONE COMPONENTE | FINITURA | Q.TA | OPERATORE |
|--------|----------------|-------------------------|---|------|-----------|
| SALONE | AZ26M-L01_SM01 | MOBILE COLONNA SX POPPA | LACCATO MOGANO (precomposto) 100 gloss | 3 | Damiano |

- 1 - L 57 x H 343 x SP 16
- 2 - L 427 x H 460 x SP 16
- 3 - L 59 x H 343 x SP 16



AZ26M

REV. 01-2023

REV. GR 9

| LOCALE | CODICE | DESCRIZIONE COMPONENTE | FINITURA | Q.TA | OPERATORE |
|--------|----------------|------------------------|-------------------------|------|-----------|
| SALONE | AZ26M-L01_SN01 | COMODINO DX CENTRONAVE | LACCATO BIANCO RAL 9010 | 3 | Damiano |

1 - 3 - L 386 x H 86 x 36
2 - L 578 x H 86 x 212

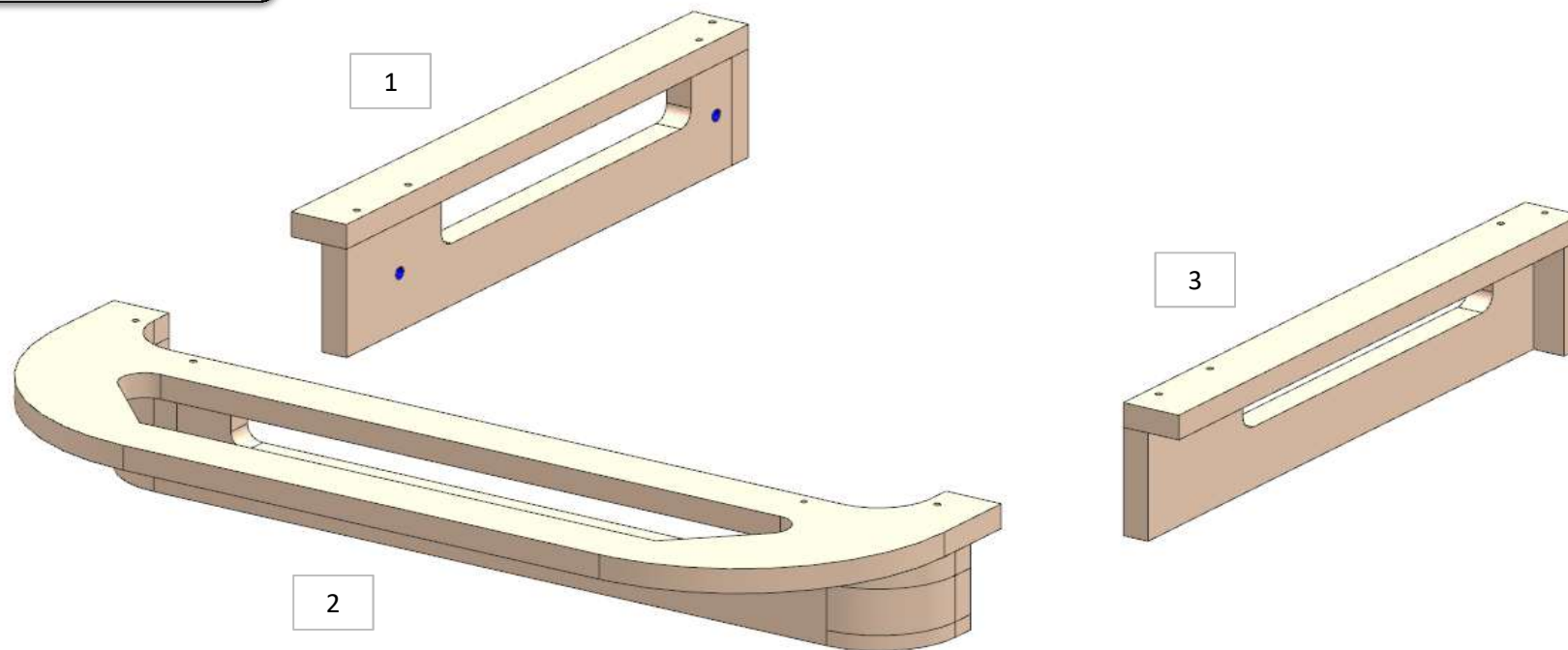

AZ26M

REV. 01-2023

REV. GR 9

| LOCALE | CODICE | DESCRIZIONE COMPONENTE | FINITURA | Q.TA | OPERATORE |
|--------|----------------|------------------------|---|------|-----------|
| SALONE | AZ26M-L02_SN01 | COMODINO DX CENTRONAVE | LACCATO MOGANO (precomposto) 100 gloss | 4 | Damiano |

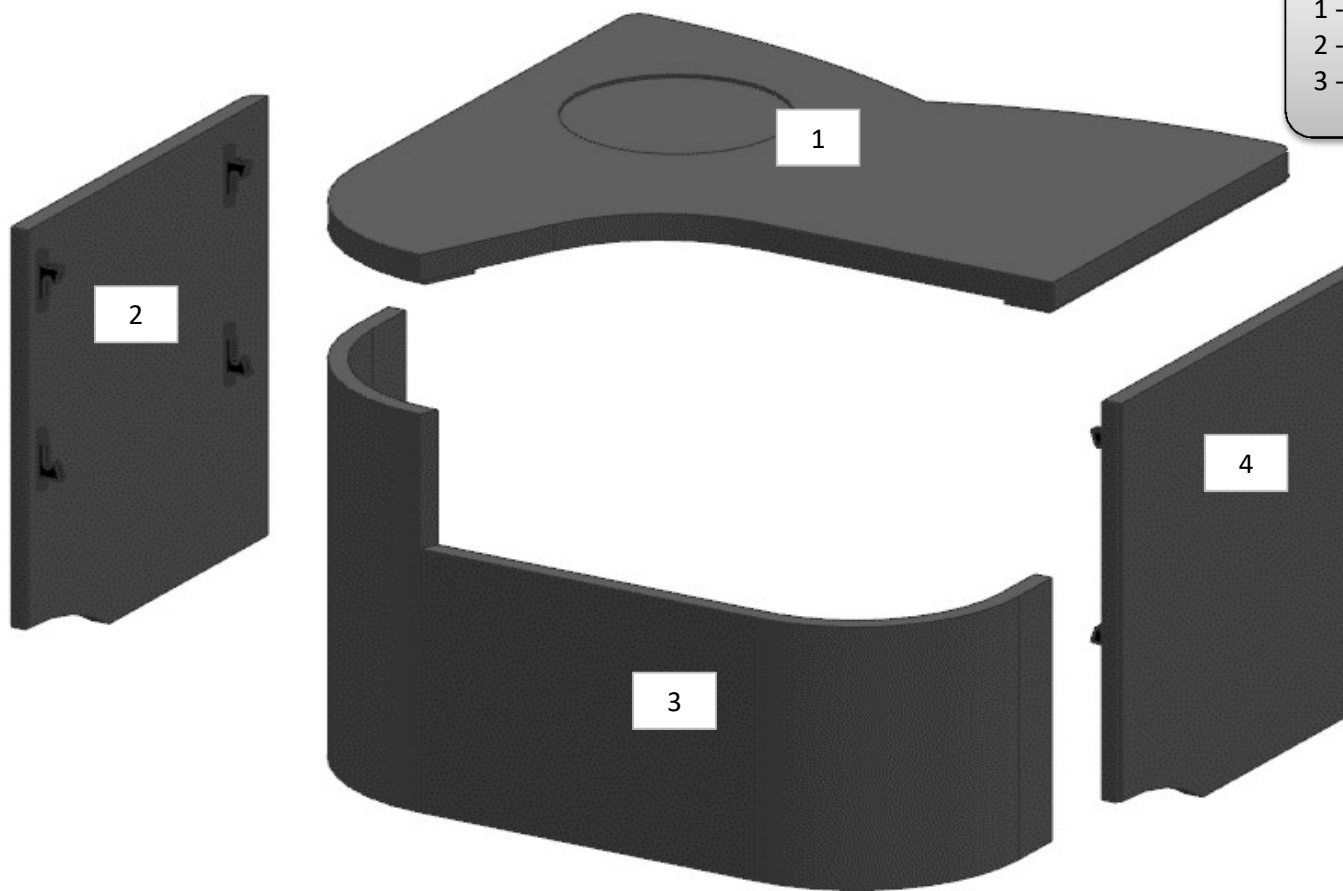

- 1 - L 610 x H 587 x sp 25
- 2 - 4 - L 368 x H 413 x sp 16
- 3 - SVILUPPO L 882 x H 375 x sp 16

AZ26M

REV. 01-2023

REV. GR 9

| LOCALE | CODICE | DESCRIZIONE COMPONENTE | FINITURA | Q.TA | OPERATORE |
|--------|----------------|------------------------|---------------|------|-----------|
| SALONE | AZ26M-R01_SO01 | COMODINO SX CENTRONAVE | LASTRA CHIARA | 2 | Damiano |

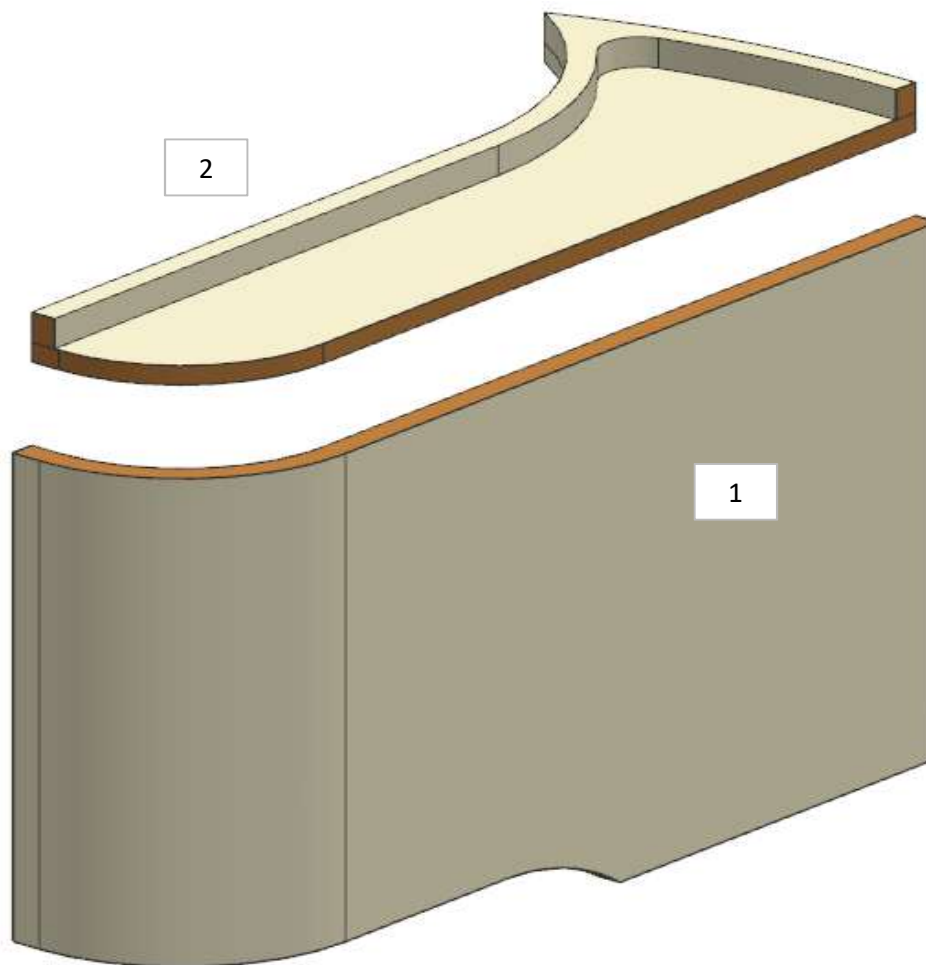

- 1 - SVILUPPO L 885 x H 445 x sp 20
- 2 - SVILUPPO L 854 x H.290 x sp 41

AZ26M

REV. 01-2023

REV. GR 9

| LOCALE | CODICE | DESCRIZIONE COMPONENTE | FINITURA | Q.TA | OPERATORE |
|--------|----------------|------------------------|-------------------------|------|-----------|
| SALONE | AZ26M-L01_SO01 | COMODINO SX CENTRONAVE | LACCATO BIANCO RAL 9010 | 3 | Damiano |

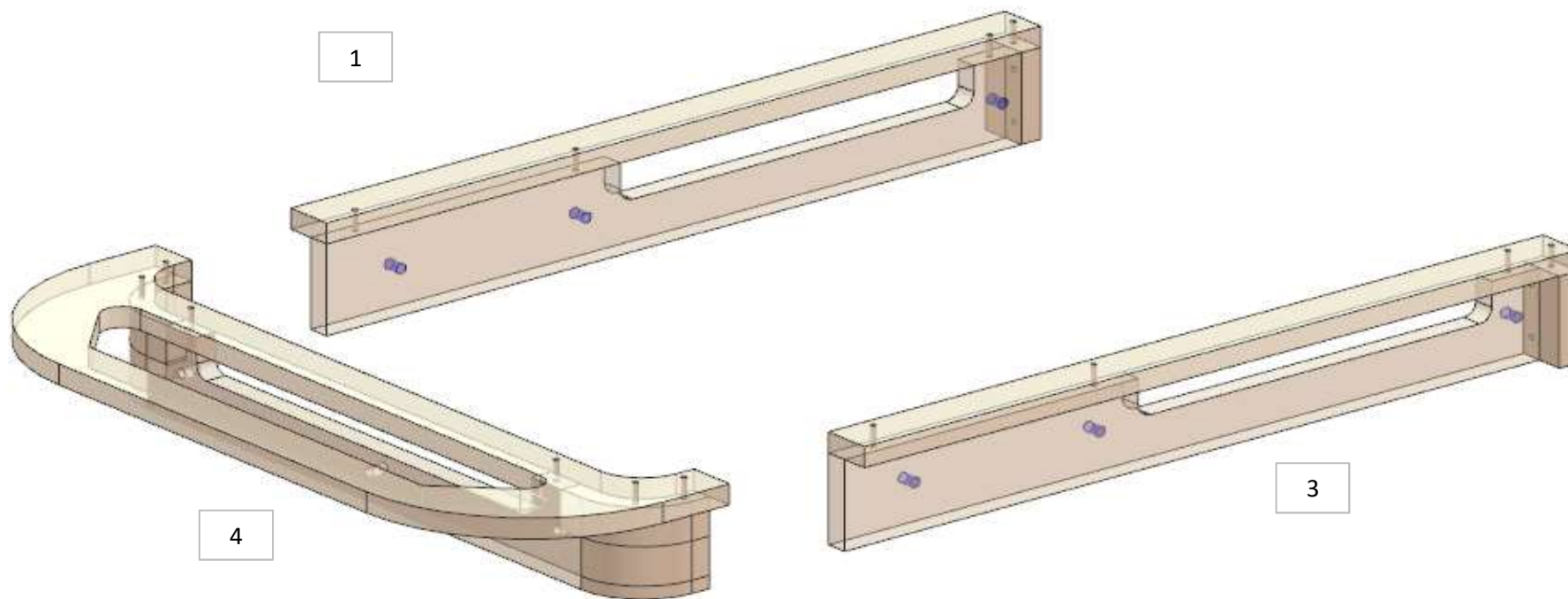

1 - 3 - L 586 x H 86 x sp 36
2 - L 578 x H 86 x 213

AZ26M

REV. 01-2023

REV. GR 9

| LOCALE | CODICE | DESCRIZIONE COMPONENTE | FINITURA | Q.TA | OPERATORE |
|--------|----------------|------------------------|---|------|-----------|
| SALONE | AZ26M-L02_SO01 | COMODINO SX CENTRONAVE | LACCATO MOGANO (precomposto) 100 gloss | 3 | Damiano |

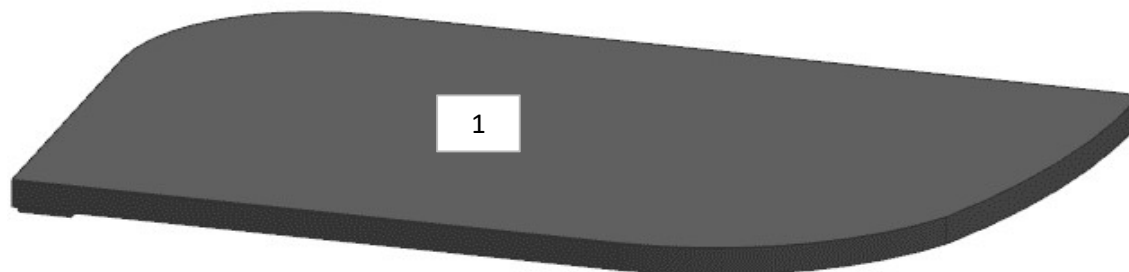

- 1 - L 786 x H 441 x sp 25
- 2 - L 563 x H 413 x sp 19
- 3 - SVILUPPO L 580 x H 374 x sp 19

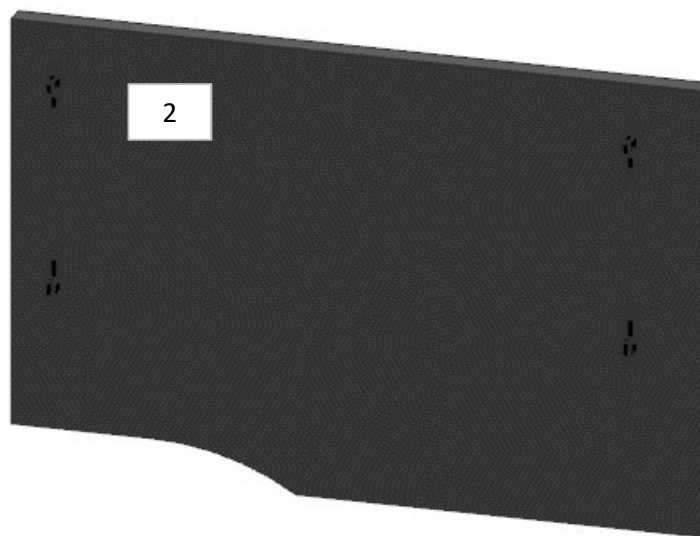
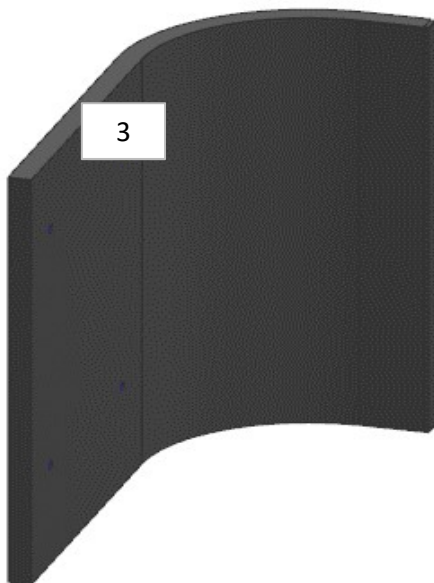

AZ26M

MOD DA GR4

REV. GR 9

| LOCALE | CODICE | DESCRIZIONE COMPONENTE | FINITURA | Q.TA | OPERATORE |
|--------|----------------|----------------------------|---------------|------|-----------|
| SALONE | AZ26M-R01_SQ01 | MOBILE IN NICCHIA DX POPPA | LASTRA CHIARA | 10 | Damiano |

- 1 - L 372 x H 2036 x sp 20
- 2 - L 467 x H.401 x sp 20
- 3 - L 215 x H 75 x sp 215
- 4 - L 472 x H 2036 x sp 20
- 5 - L 491 x H 485 x sp 16
- 6 - L 431 x H 455 x sp 16
- 7 - L 465 x H 213 x sp 45
- 8 - L 346 x H 41 x sp 16
- 9 - L 465 x H 213 x sp 45
- 10 - L 346 x H 76 x sp 32

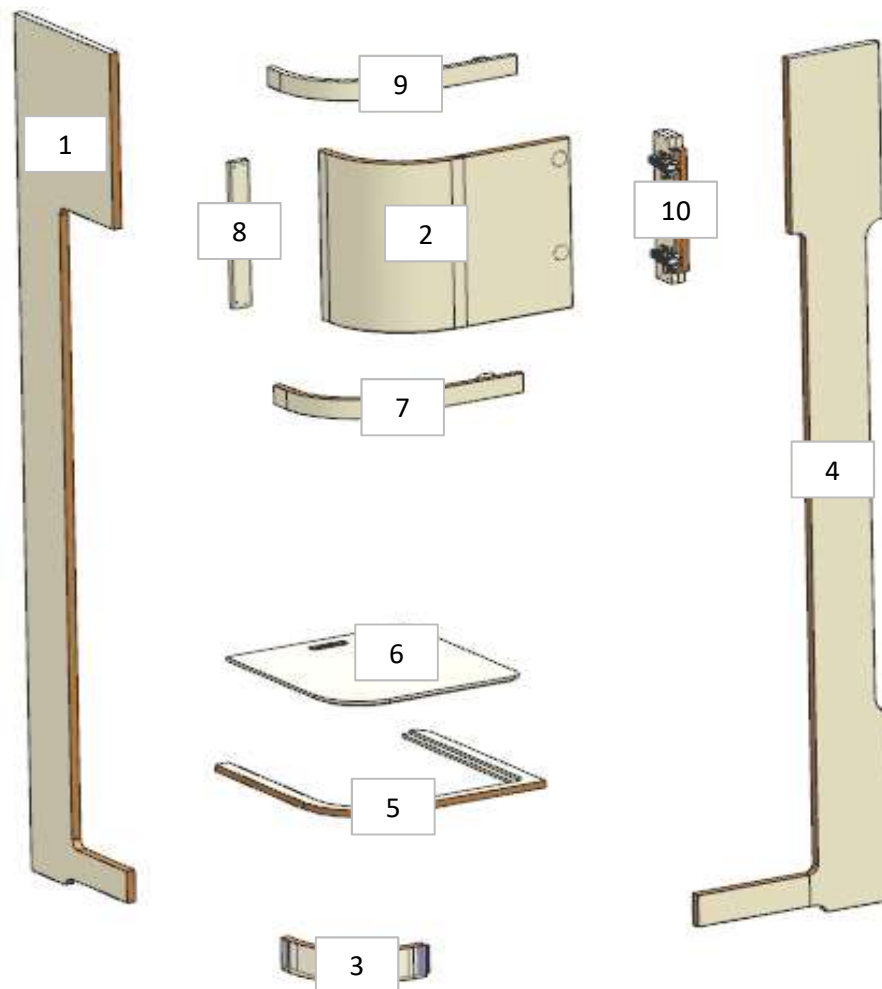

MOD AZ 155
reso apribile
cappello per
aumento storage

AZ26M

MOD GR4

REV. GR 9

| LOCALE | CODICE | DESCRIZIONE COMPONENTE | FINITURA | Q.TA | OPERATORE |
|--------|----------------|----------------------------|---|------|-----------|
| SALONE | AZ26M-L01_SQ01 | MOBILE IN NICCHIA DX POPPA | LACCATO MOGANO (precomposto) 100 gloss | 1 | Damiano |

1 - L 524 x H 1642 x sp 20

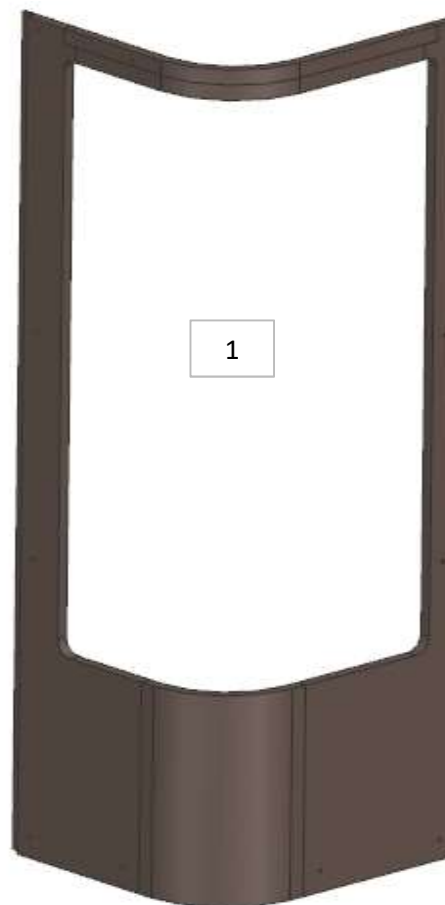

MOD AZ 155
reso apribile
cappello per
aumento storage

consonni&c

AZ26M

REV. 01-2023

REV. GR 9

| LOCALE | CODICE | DESCRIZIONE COMPONENTE | FINITURA | Q.TA | OPERATORE |
|--------|----------------|---------------------------|---------------|------|-----------|
| SALONE | AZ26M-R01_SR01 | MOBILE SUBWOOFER SX POPPA | LASTRA CHIARA | 10 | Damiano |

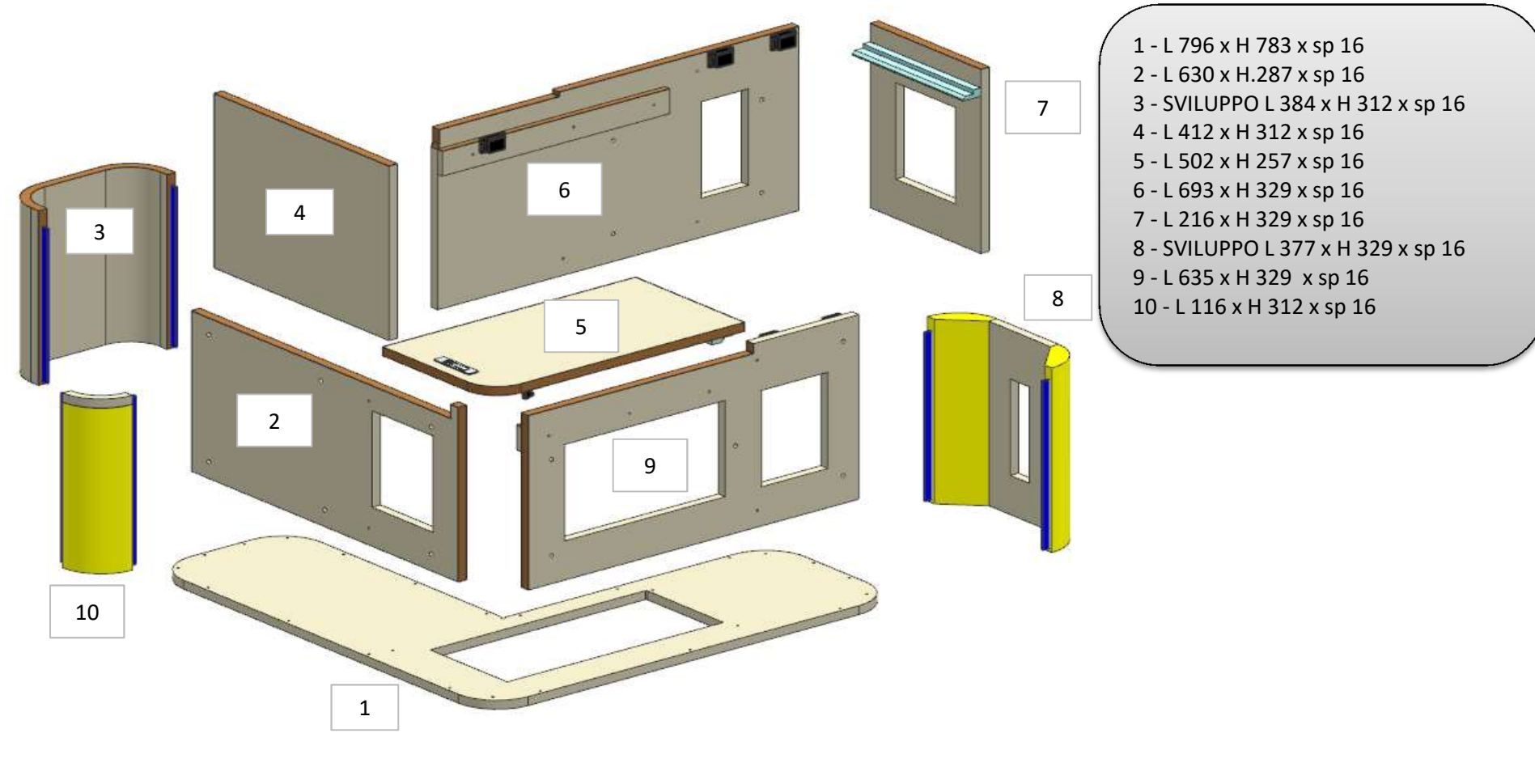

- 1 - L 796 x H 783 x sp 16
- 2 - L 630 x H.287 x sp 16
- 3 - SVILUPPO L 384 x H 312 x sp 16
- 4 - L 412 x H 312 x sp 16
- 5 - L 502 x H 257 x sp 16
- 6 - L 693 x H 329 x sp 16
- 7 - L 216 x H 329 x sp 16
- 8 - SVILUPPO L 377 x H 329 x sp 16
- 9 - L 635 x H 329 x sp 16
- 10 - L 116 x H 312 x sp 16

AZ26M

REV. 01-2023

REV. GR 9

| LOCALE | CODICE | DESCRIZIONE COMPONENTE | FINITURA | Q.TA | OPERATORE |
|--------|----------------|---------------------------|-------------------------|------|-----------|
| SALONE | AZ26M-L01_SR01 | MOBILE SUBWOOFER SX POPPA | LACCATO BIANCO RAL 9010 | 4 | Damiano |

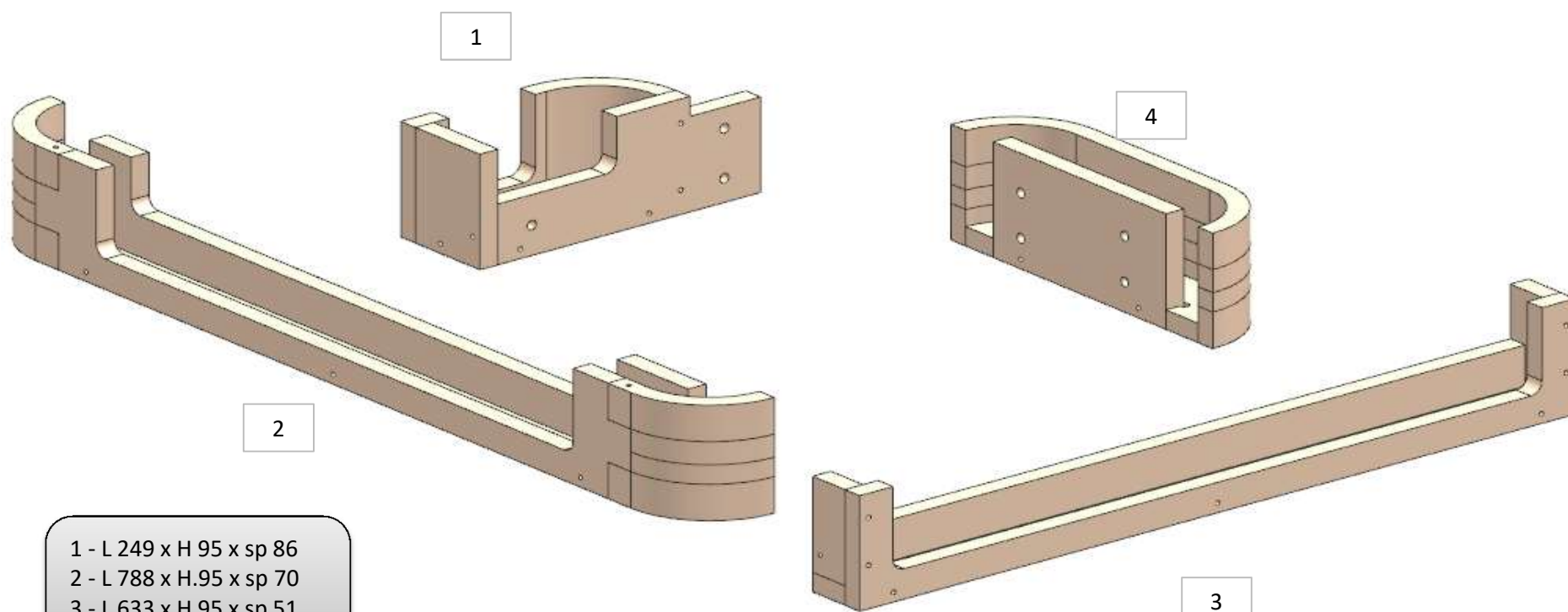

- 1 - L 249 x H 95 x sp 86
- 2 - L 788 x H.95 x sp 70
- 3 - L 633 x H 95 x sp 51
- 4 - L 285 x H 95 x sp 70

AZ26M

REV. 01-2023

REV. GR 9

| LOCALE | CODICE | DESCRIZIONE COMPONENTE | FINITURA | Q.TA | OPERATORE |
|--------|----------------|---------------------------|---|------|-----------|
| SALONE | AZ26M-L02_SR01 | MOBILE SUBWOOFER SX POPPA | LACCATO MOGANO (precomposto) 100 gloss | 6 | Damiano |

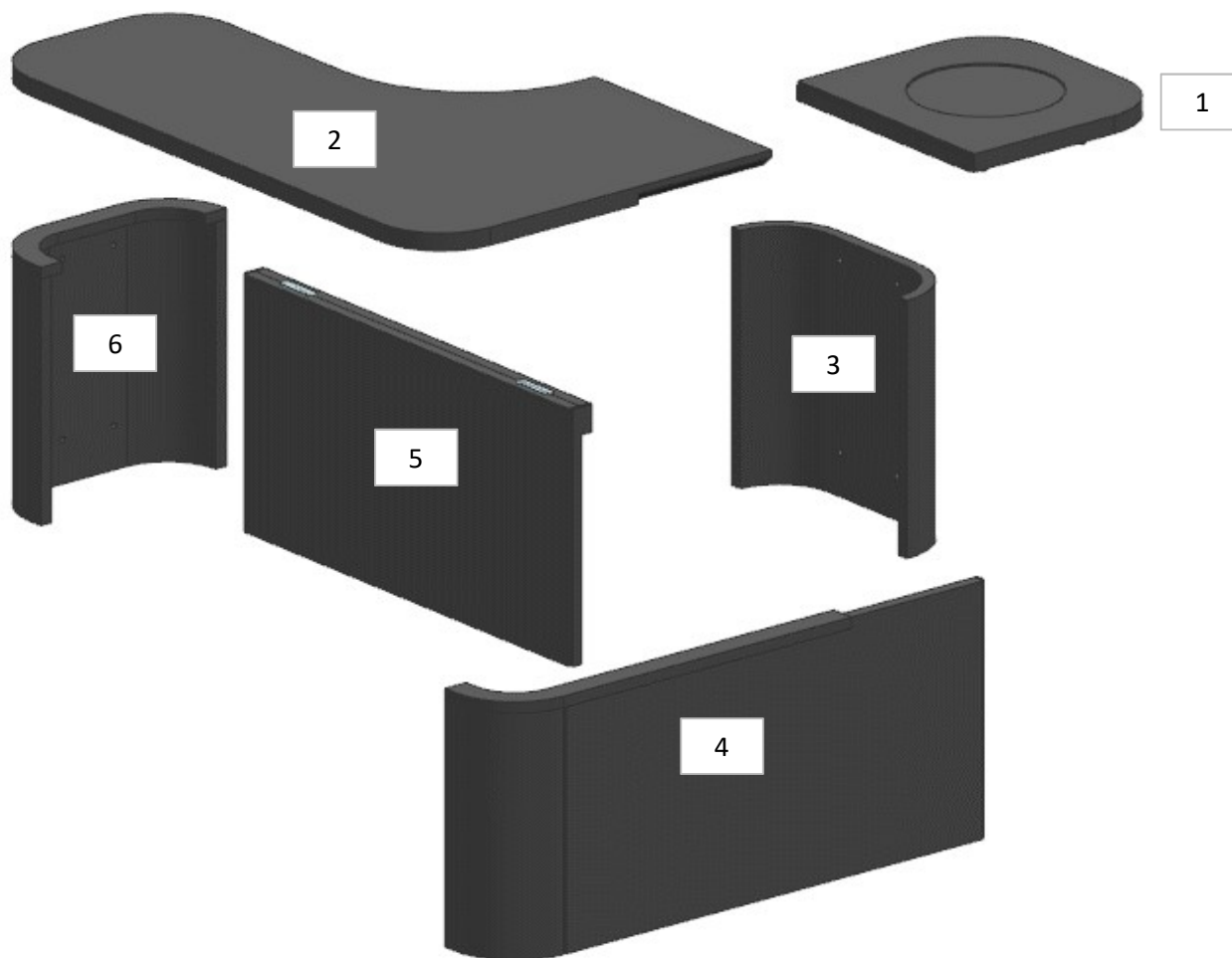

- 1 - L 319 x H 303 x sp 25
- 2 - L 828 x H.512 x sp 25
- 3 - SVILUPPO L 426 x H 360 x sp 16
- 4 - SVILUPPO L 792 x H 360 x sp 32
- 5 - L 605 x H.359 x sp 32
- 6 - SVILUPPO L 418 x H 360 x sp 32

AZ26M

REV. GR 9

| LOCALE | CODICE | DESCRIZIONE COMPONENTE | FINITURA | Q.TA | OPERATORE |
|--------|----------------|---------------------------|----------------|------|-----------|
| SALONE | AZ26M-L01_SY01 | CIELINO ZONA TV A DISCESA | LACCATO BRONZO | 1 | Damiano |

1 - L 1268 x H 728 x sp 12



consonni&c

AZ26M

REV. GR 10

| LOCALE | CODICE | DESCRIZIONE COMPONENTE | FINITURA | Q.TA | OPERATORE |
|--------|----------------|-------------------------|---------------|------|-----------|
| SALONE | AZ26M-R01_SZ01 | PORTA SCORREVOLE SALONE | LASTRA CHIARA | 1 | Damiano |

VERIFICARE LATO
FRONTALE E MASSELLI
CHE LA VENA SIA A 45°
E SUL RETRO IN
VERTICALE

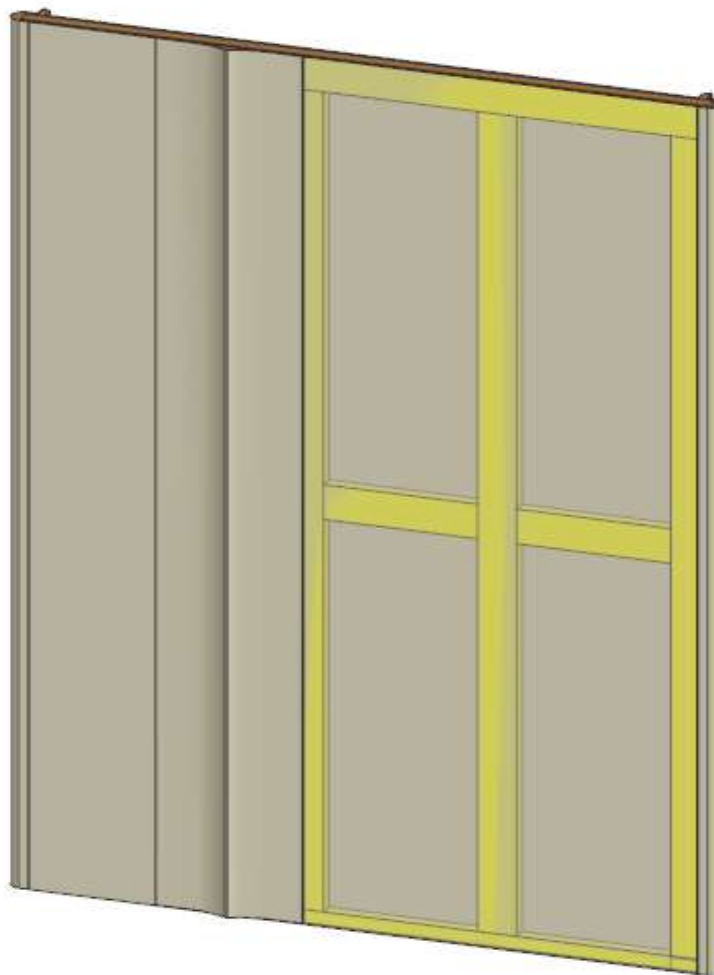

consonni&c