

LOCALE	CODICE	DESCRIZIONE COMPONENTE	FINITURA	GR.
CABINA VIP	MD321_VA01	ARMADIO SX	LAMINATO SM'ART ES04 JUNGLE ANICE	2

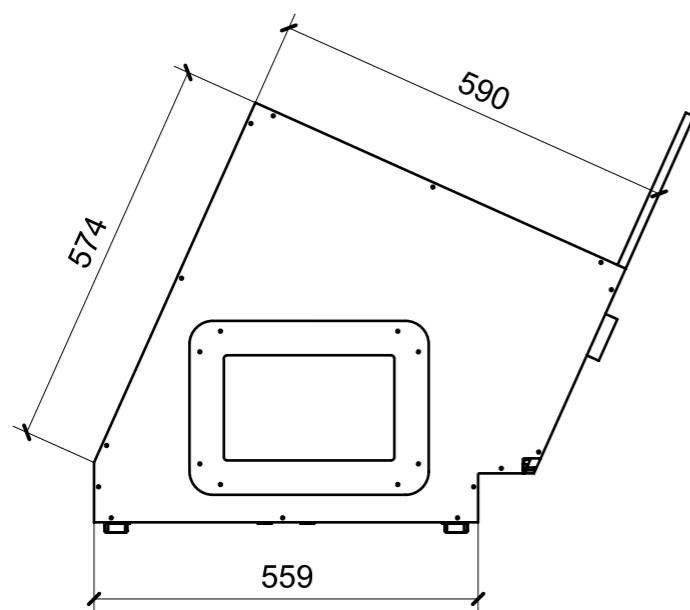
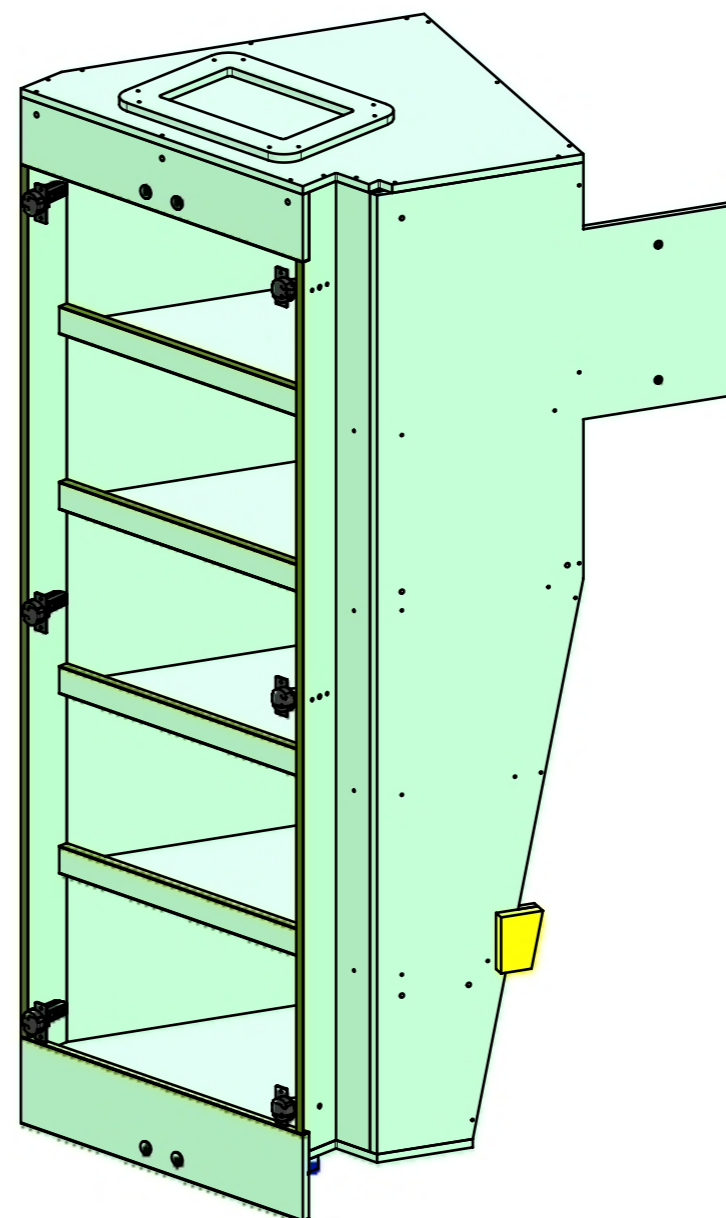
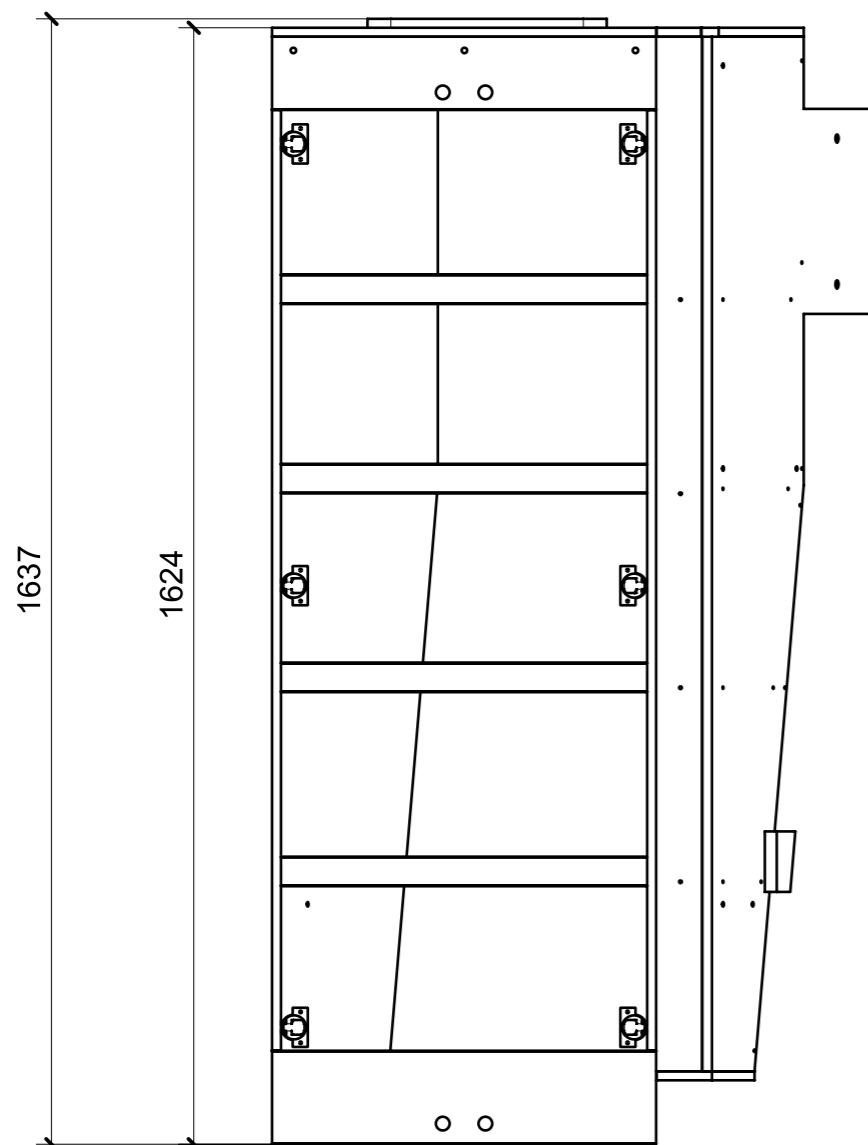

01

FERRAMENTA	QTY
RISCONTRO IN FERRO PER CALAMITA TONDO	4
BASE_3-NERA_HAFELE_342.22.067-BLUM_175H3130.STP	6
CERNIERA 94°_MEZZO COLLO-NERA_HAFELE_342.46.605-BLUM_71B9650	6
KIT LED PER ARMADIO MD321 VA01 MM 530_	1
VITE 4MAX8 ANKOR BORGHI	12
RISCONTRO IN FERRO PER CALAMITA DA FAR PRODURRE X MD321	4
BUSSOLA 5MA ANKOR BORGHI	12
BUSSOLA 6MA X 10 FORO DIAM.8	2

LOCALE	CODICE	DESCRIZIONE COMPONENTE	FINITURA	GR.
CABINA VIP	MD321_VB01	MURATA SX	OKUME' GREZZO	2

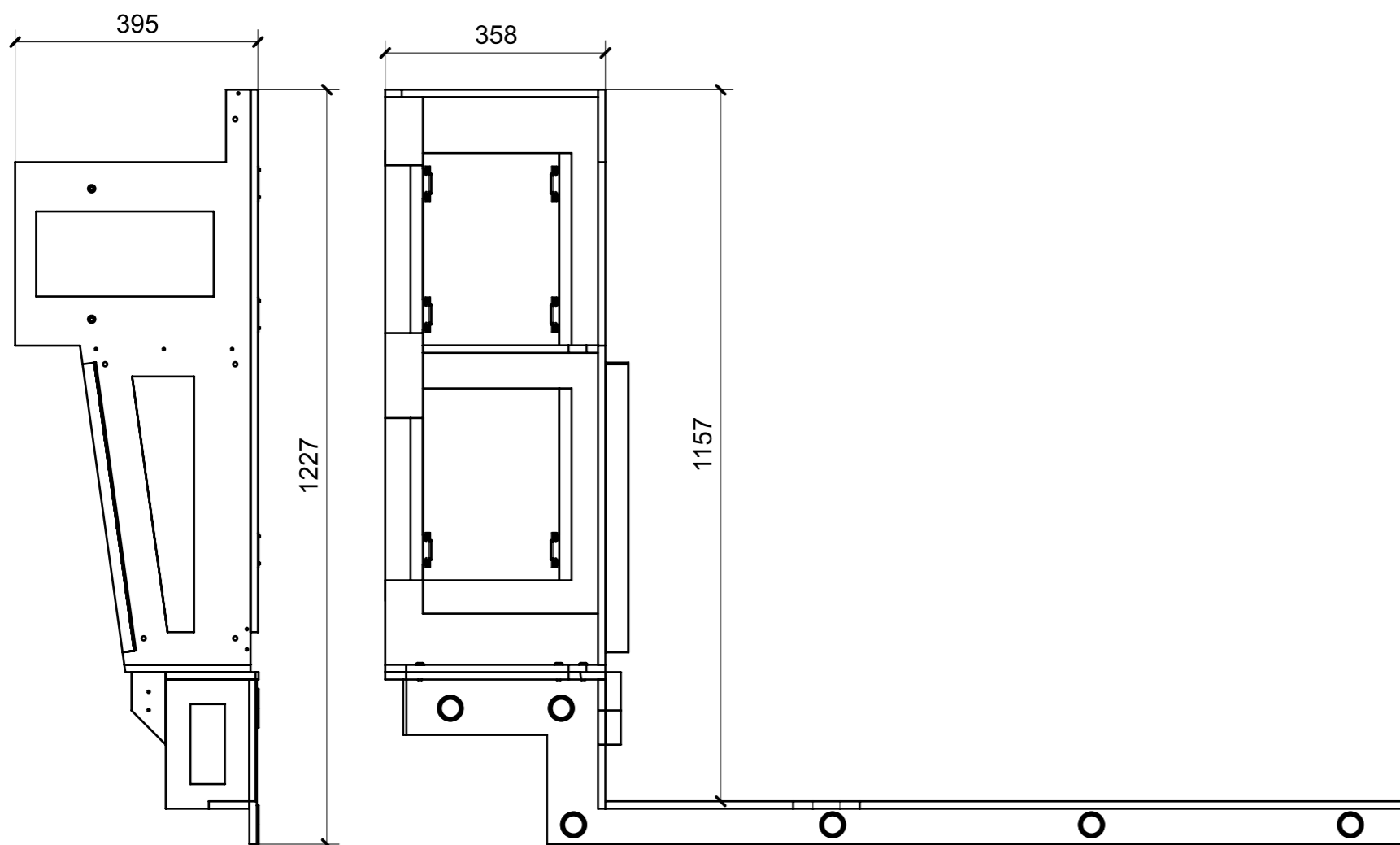

01

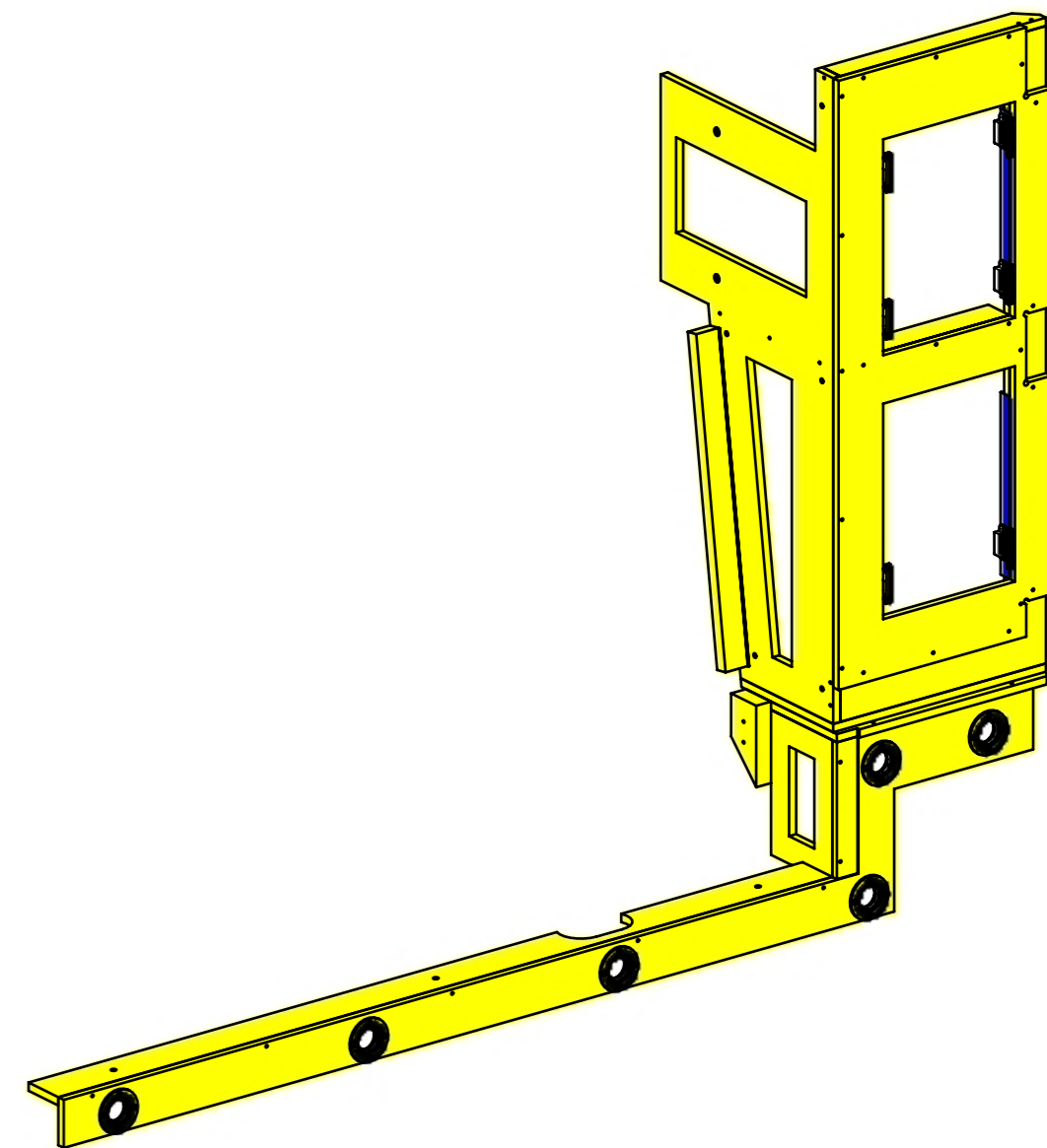

FERRAMENTA	QTY
VITE 6MA X 25 TESTA BOMBATA	3
FITLOCK F_MASCHERPA_6020101102	6
CHIUSURA A SPINTA_TECHNOPARTNER_SOU C3-203	6
BUSSOLA 6MA X 10 FORO DIAM.8	5

LOCALE	CODICE	DESCRIZIONE COMPONENTE	FINITURA	GR.
CABINA VIP	MD321_VC01	PENSILE SX	LAMINATO SM'ART ES04 JUNGLE ANICE	PTP

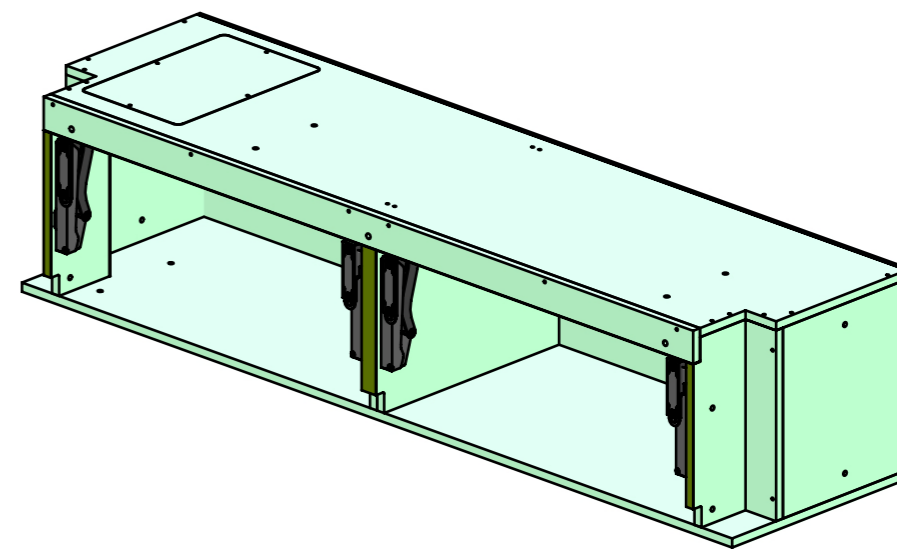
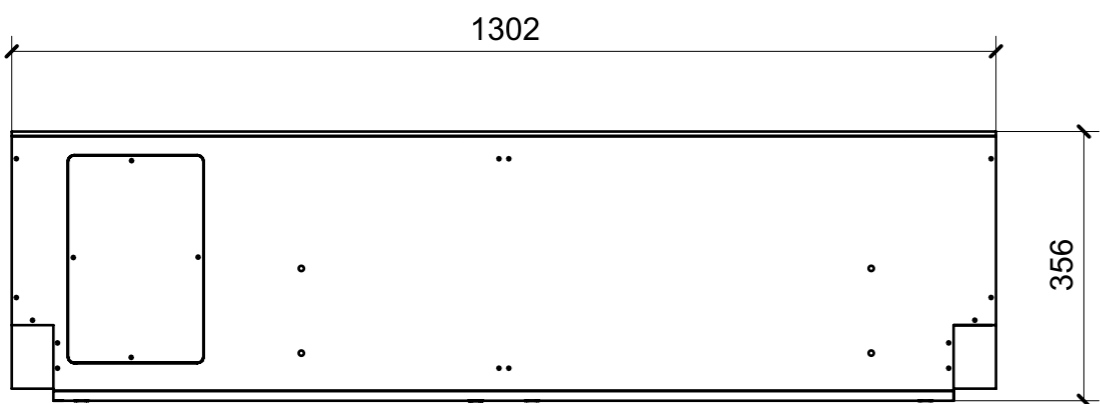
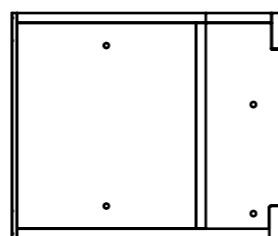
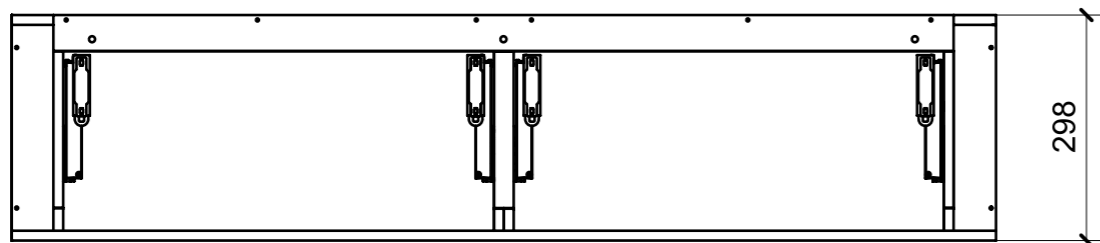

01

FERRAMENTA	QTY
CP BRACCIO PER ANTA A RIBALTA _HAFELE FREE SPACE 1.11_372_27_301	2

LOCALE	CODICE	DESCRIZIONE COMPONENTE	FINITURA	GR.
CABINA VIP	MD321_VD01	PLENUM SX	GREZZO VERNICIATO ANTI ROMBO	2

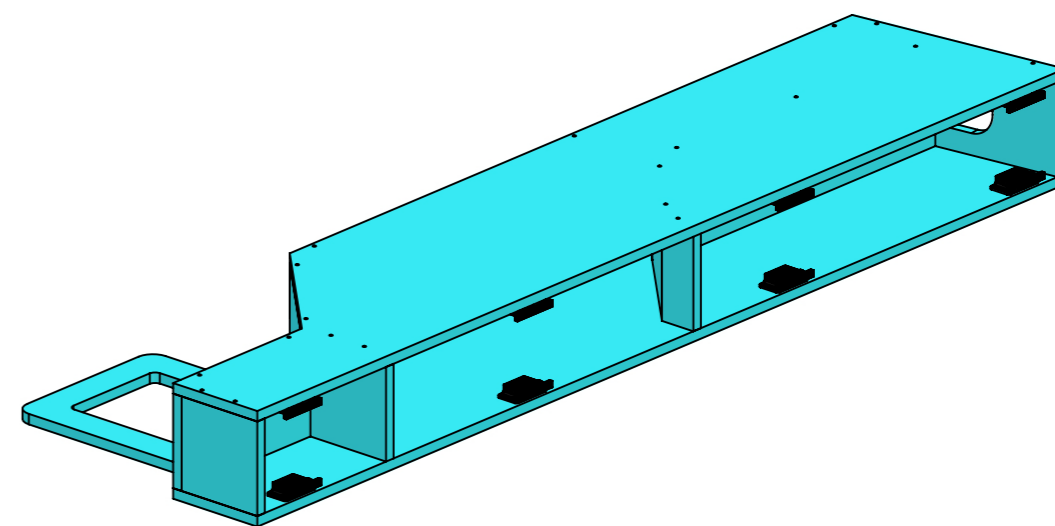
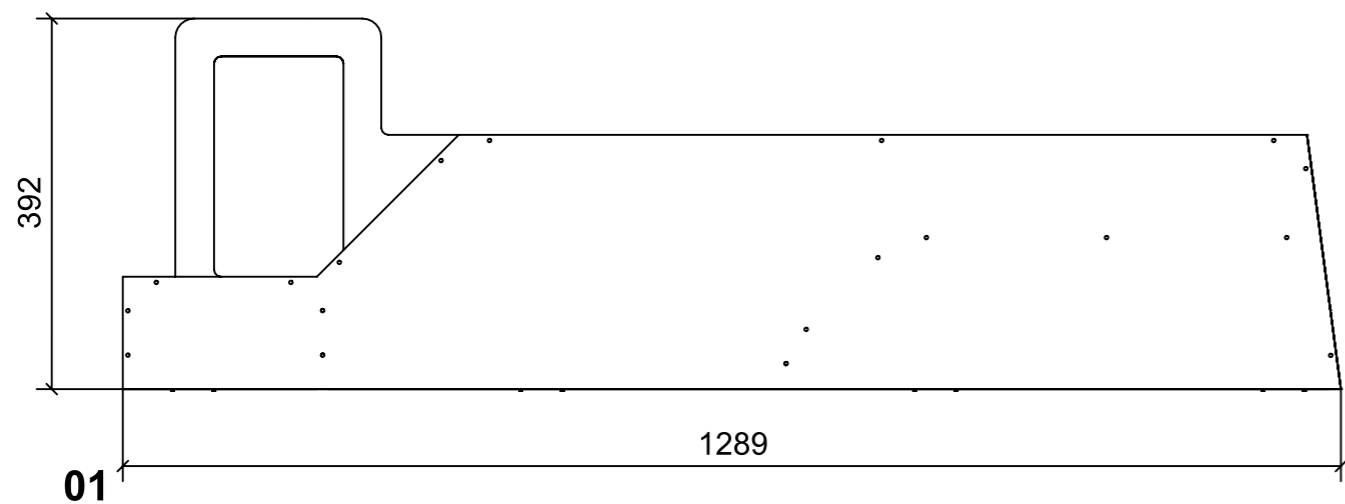
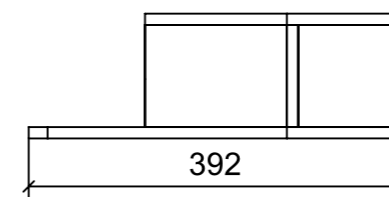
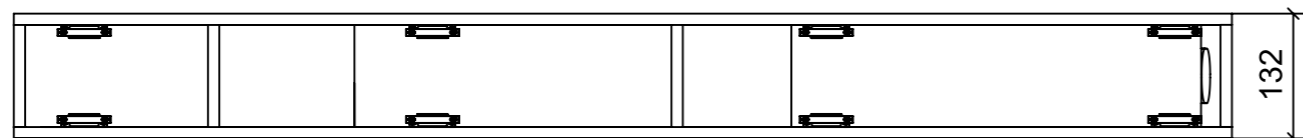

FERRAMENTA	QTY
CHIUSURA A SPINTA_TECHNOPARTNER_SOU C3-203	8
BUSSOLA 6MA X 10 FORO DIAM.8	4

LOCALE	CODICE	DESCRIZIONE COMPONENTE	FINITURA	GR.
CABINA VIP	MD321_VF01	PANNELLO OBLO' SX	LAMINATO SIMIL CIELINI	PTP

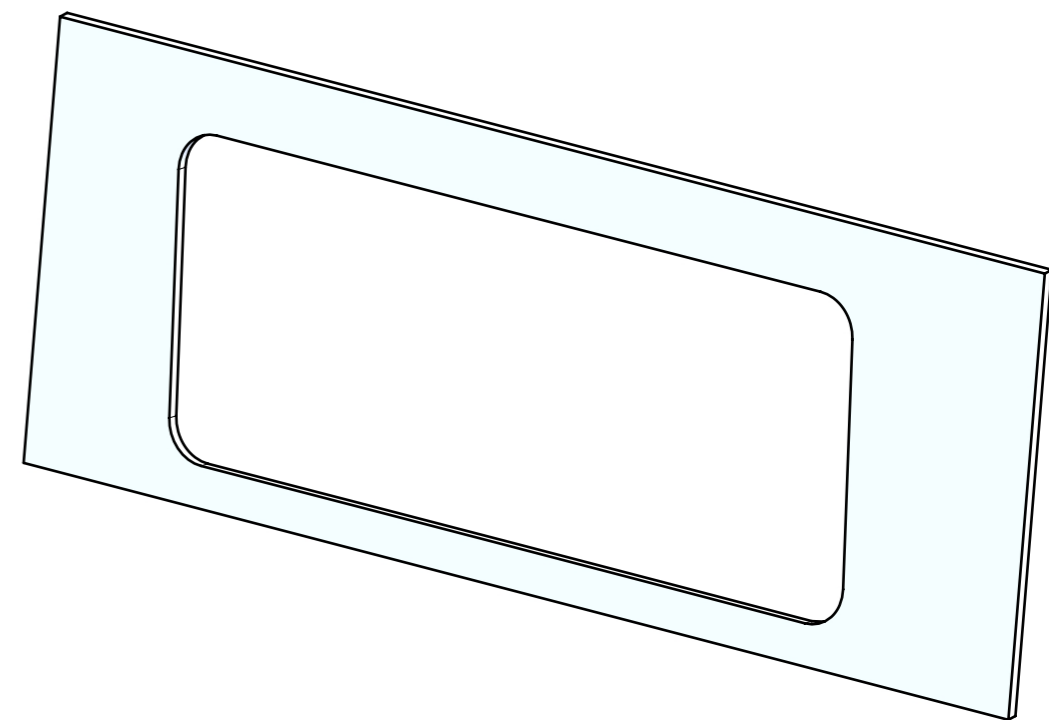
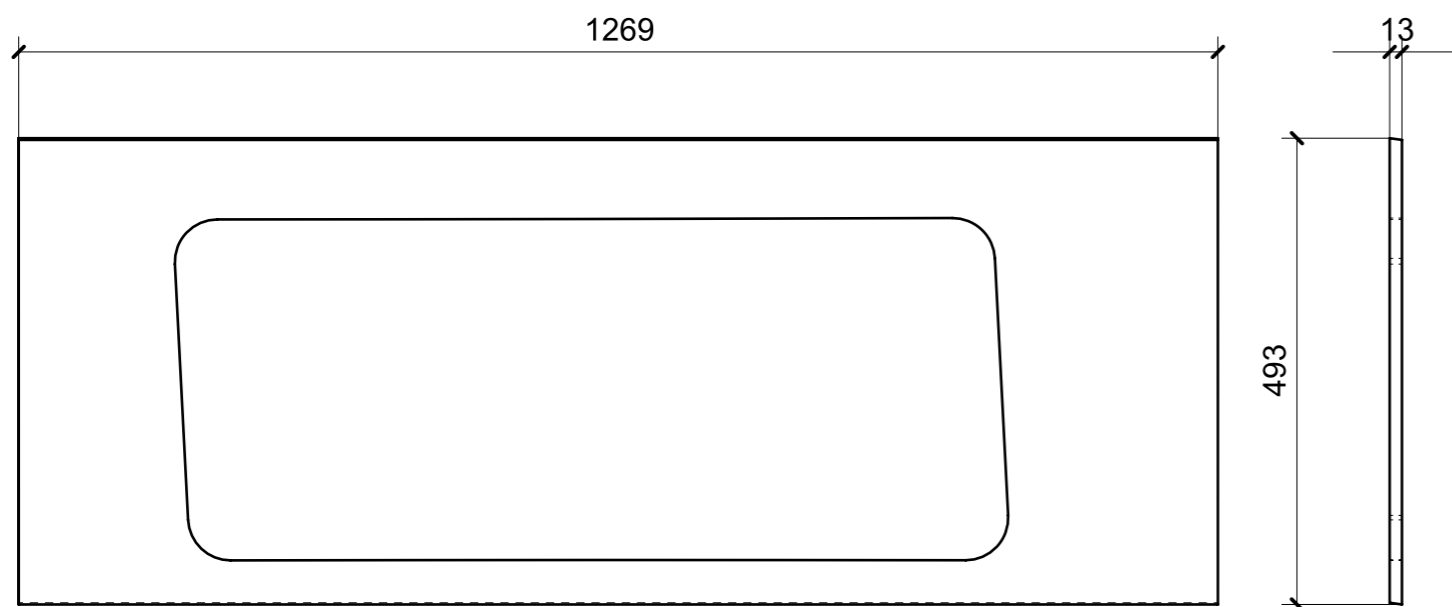

01

LOCALE	CODICE	DESCRIZIONE COMPONENTE	FINITURA	GR.
CABINA VIP	MD321_VH01	TESTATA LETTO	OKUME' GREZZO	2

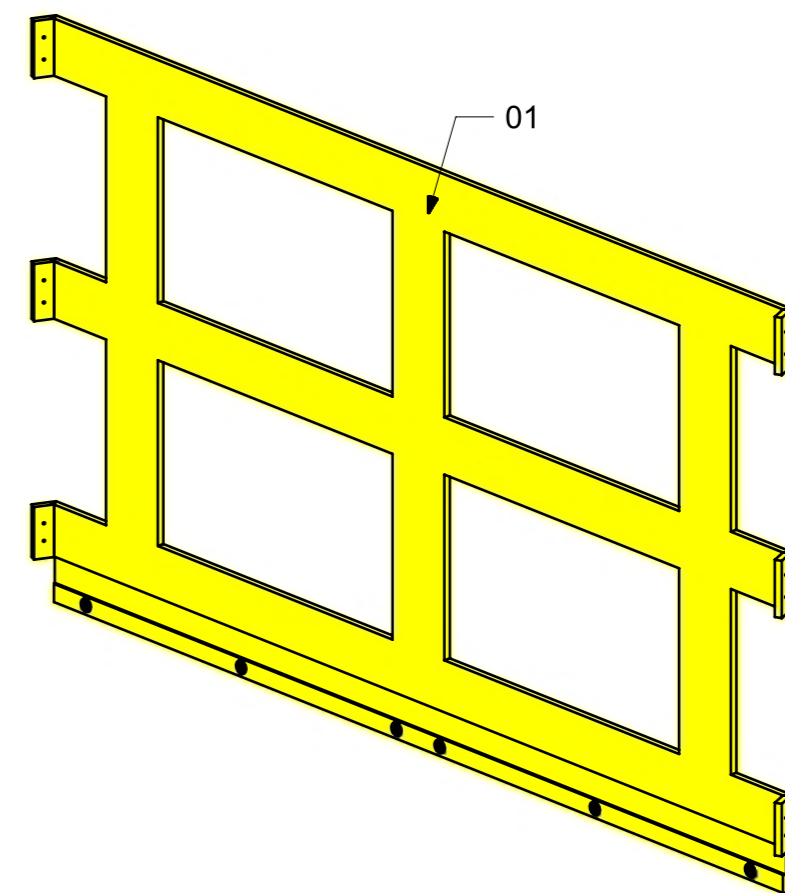
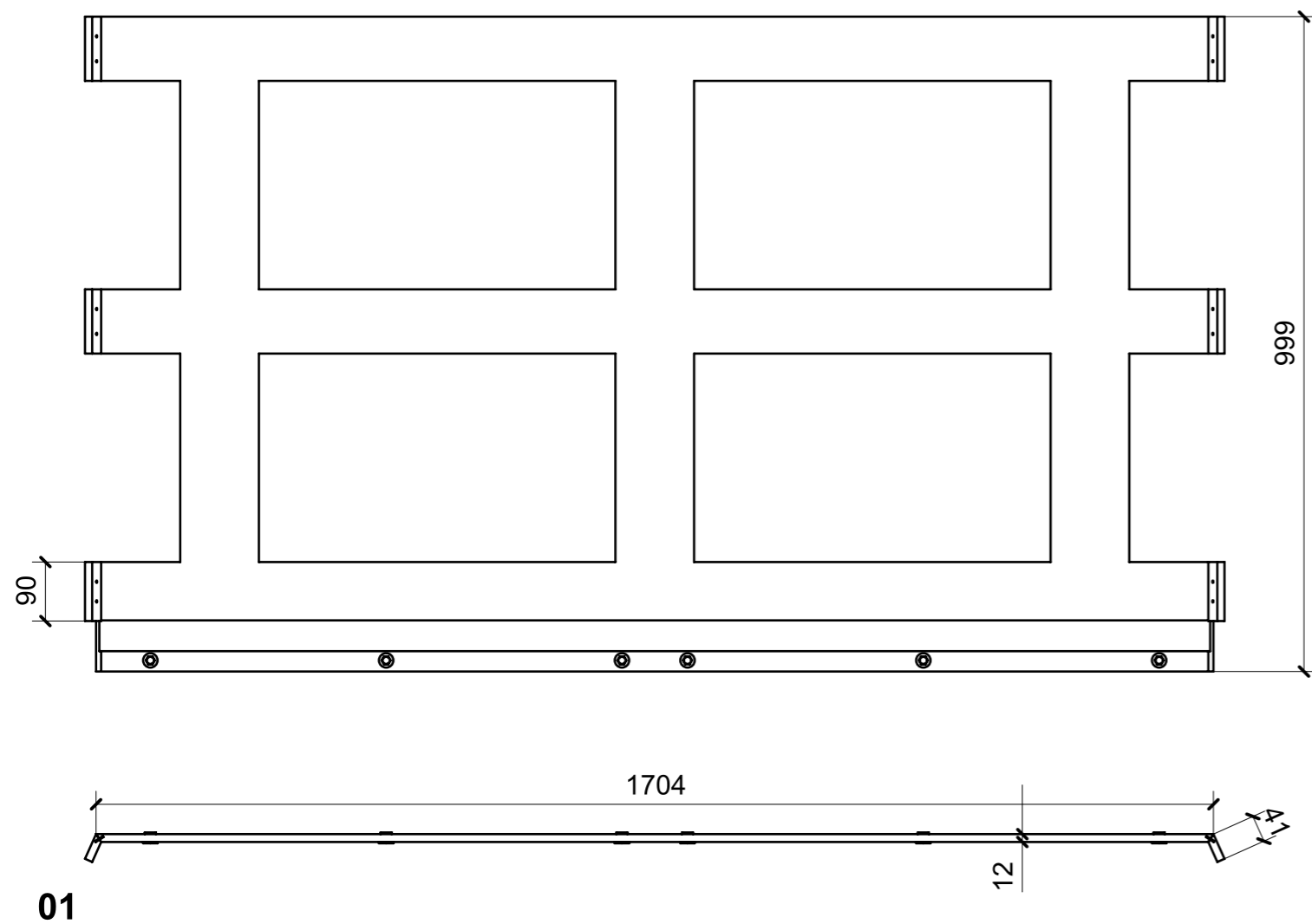

FERRAMENTA	QTY
FM INCASSO_ITALVIPLA_973_FMPC_F1A	6

LOCALE	CODICE	DESCRIZIONE COMPONENTE	FINITURA	GR.
CABINA VIP	MD321_VI01	LETTO	LAMINATO SM'ART ES04 JUNGLE ANICE	PTP

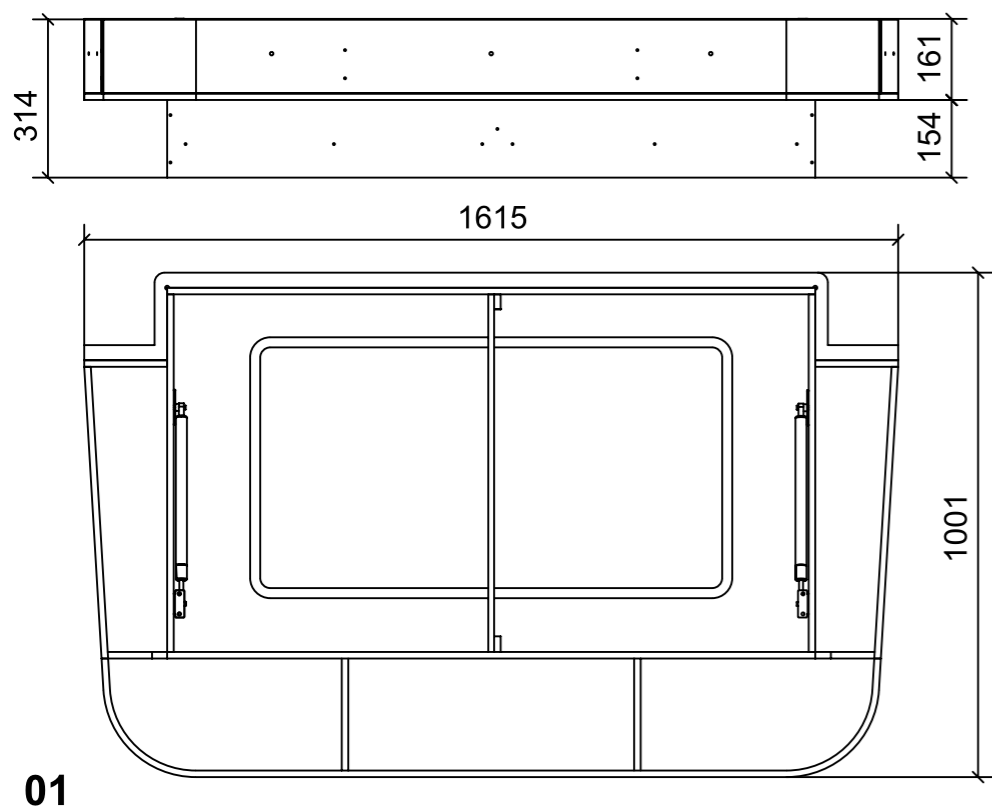

01

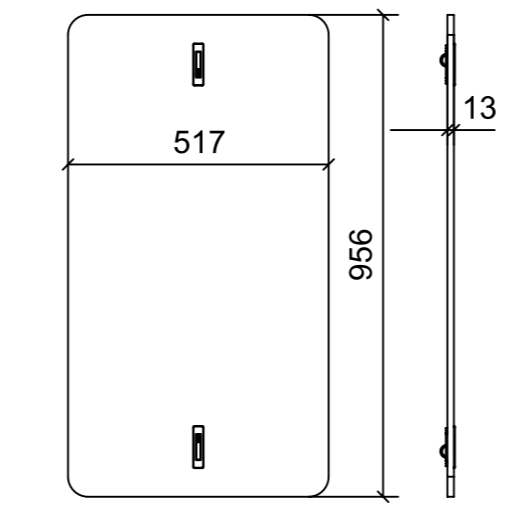

03

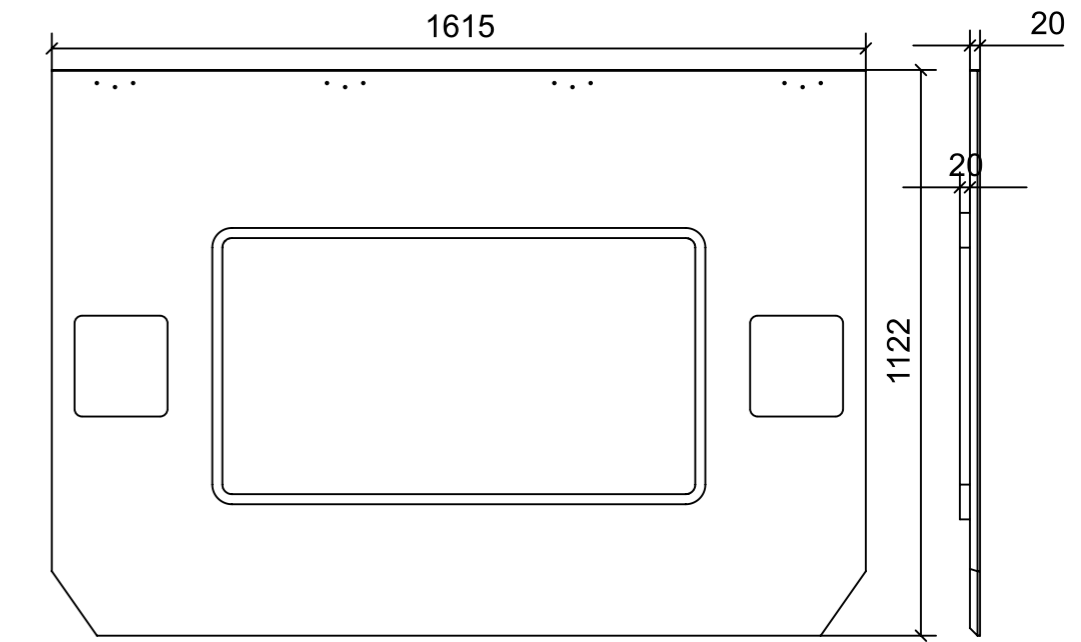

04

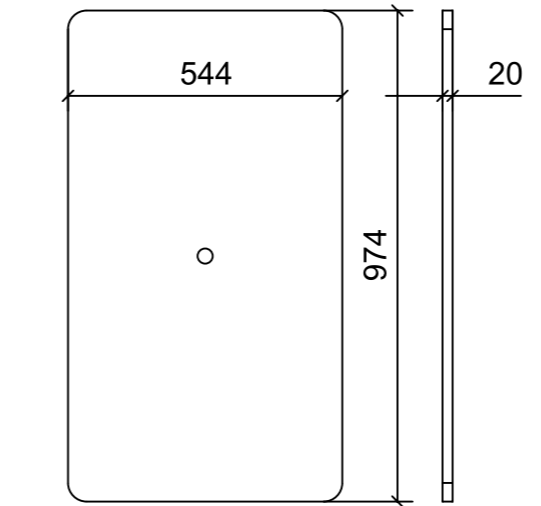

05

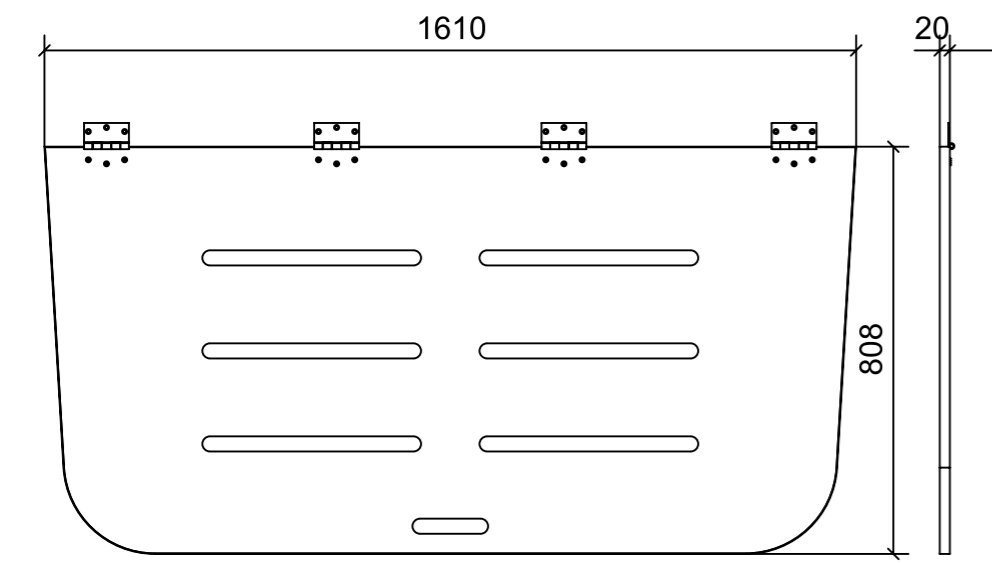

02

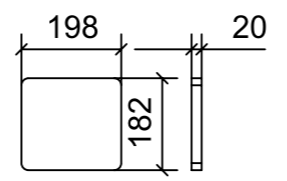

06

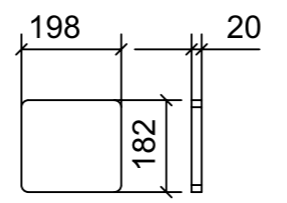

07

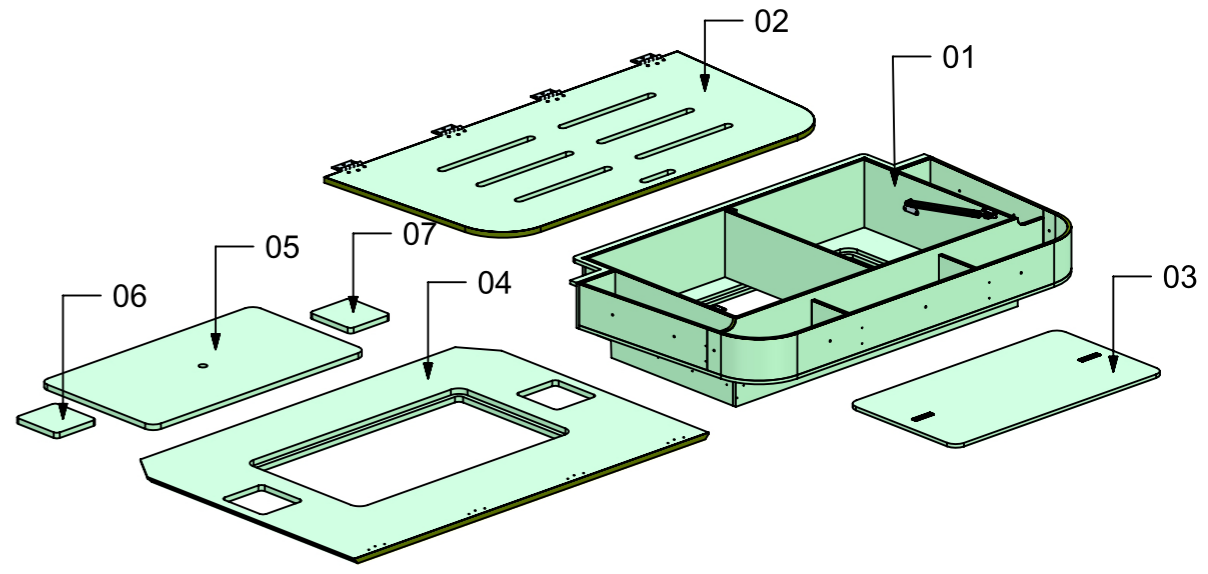

FERRAMENTA	QTY
ATACCO PIANO STABILUS 8264WV	1
ATACCO PIANO SA X PISTONE 8261WJ	1
CERNIERA PIANA PESANTE 124 90X90 TBC	4
CANOTTO PER GIUNZIONE M4X15 FBC	12
VITE TP SVASATA 4MAX12	12
VITE 4MA X 12 TESTA SVASATA ESAGONALE NERA_FBC	4
ALZAPAGLIOLI_FORESTI_164.B BRUNITON	2

LOCALE	CODICE	DESCRIZIONE COMPONENTE	FINITURA	GR.
CABINA VIP	MD321_VM01	PANNELLO OBLO' DX	LAMINATO SIMIL CIELINI	PTP

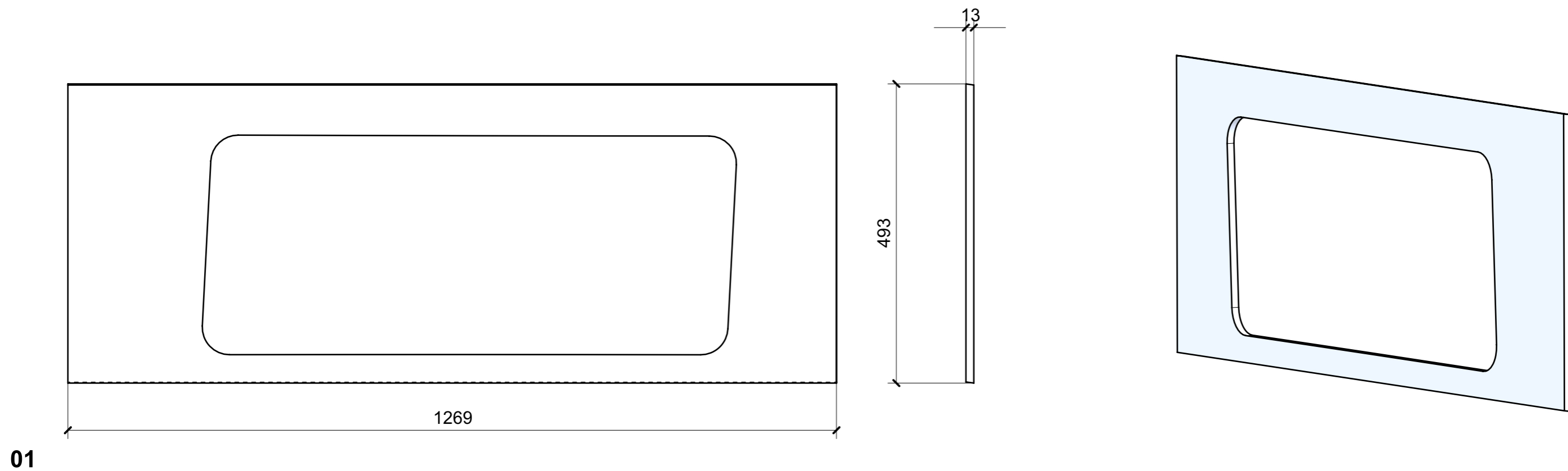

LOCALE	CODICE	DESCRIZIONE COMPONENTE	FINITURA	GR.
CABINA VIP	MD321_VO01	PLENUM DX	GREZZO VERNICIATO ANTI ROMBO	2

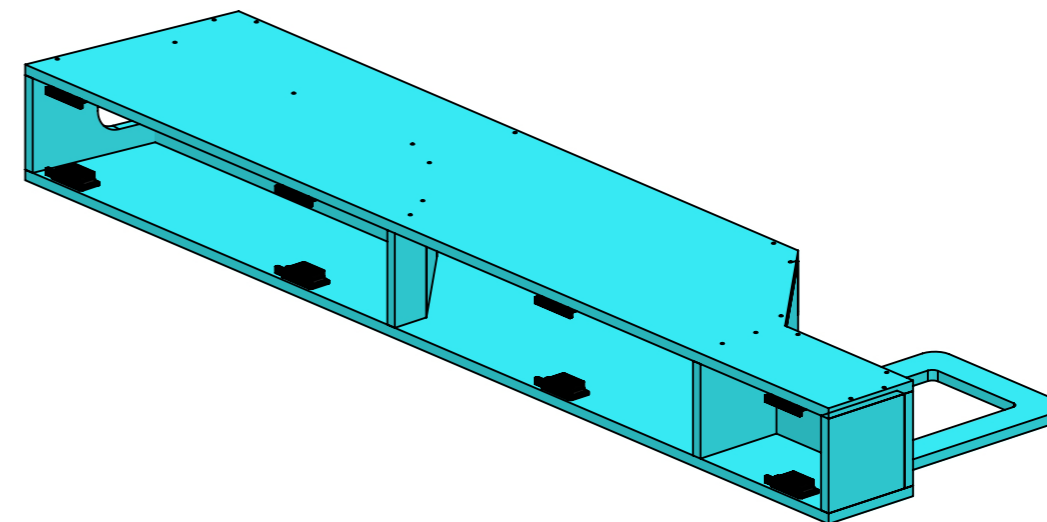
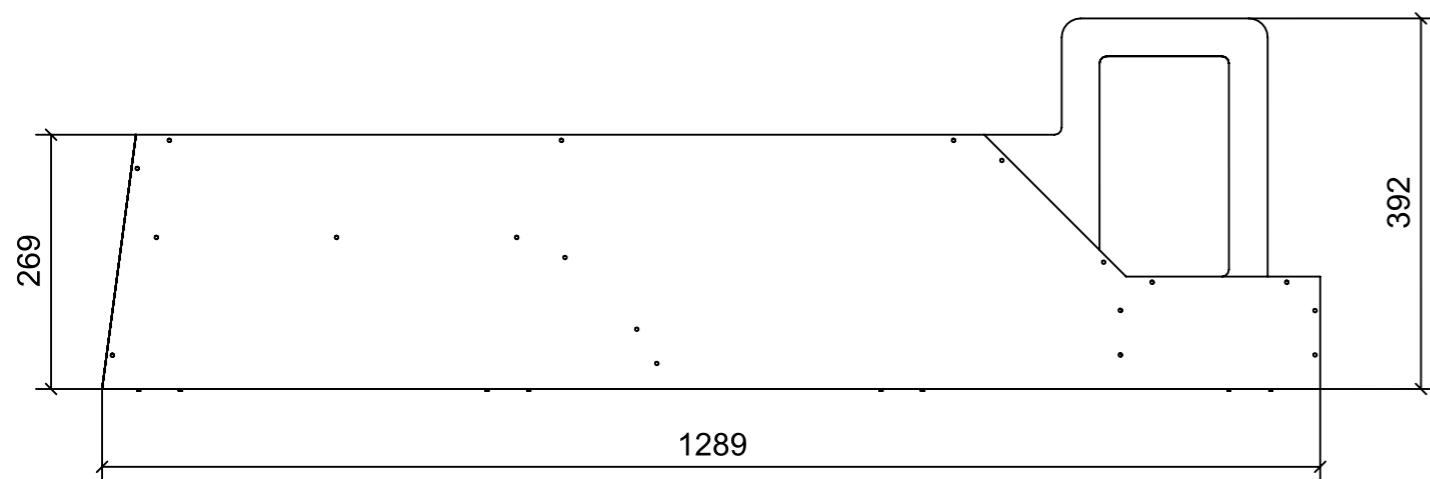
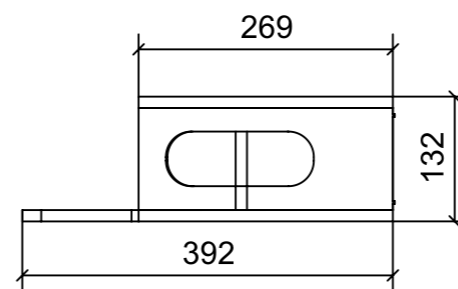
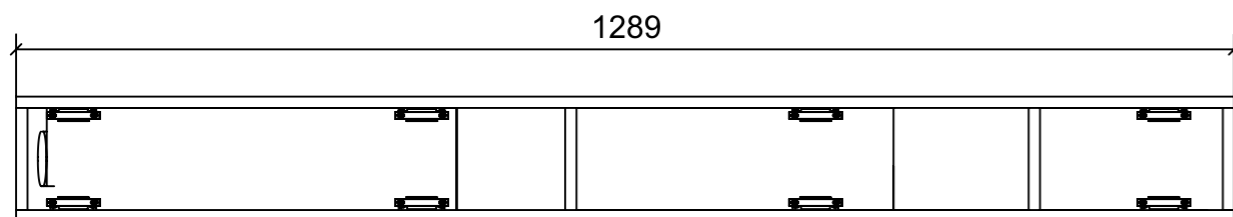

FERRAMENTA	QTY
CHIUSURA A SPINTA_TECHNOPARTNER_SOU C3-203	8
BUSSOLA 6MA X 10 FORO DIAM.8	4

LOCALE	CODICE	DESCRIZIONE COMPONENTE	FINITURA	GR.
CABINA VIP	MD321_VP01	PENSILE DX	LAMINATO SM'ART ES04 JUNGLE ANICE	PTP

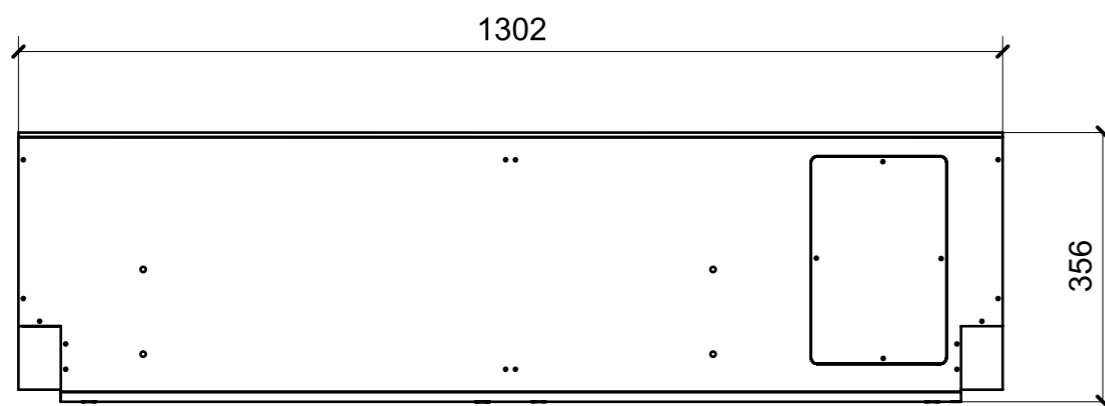
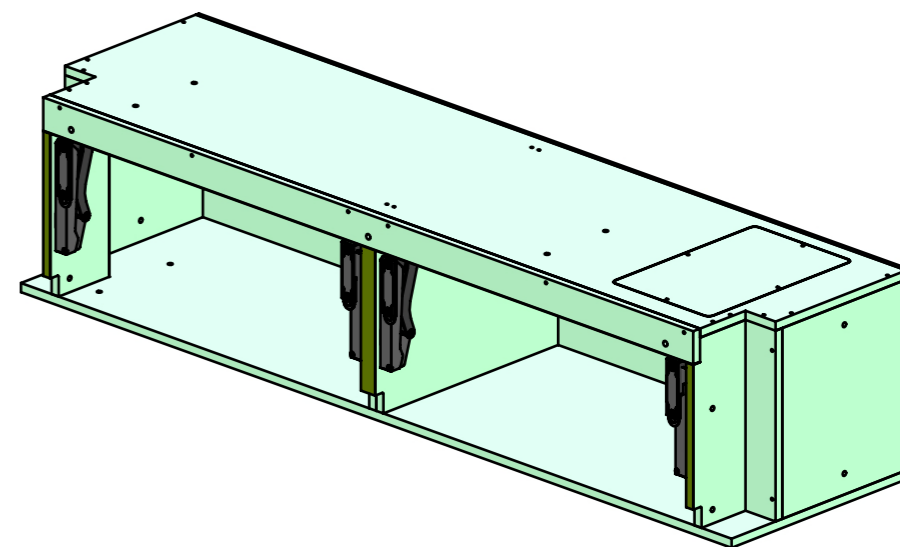
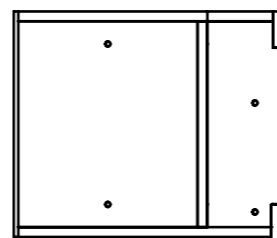
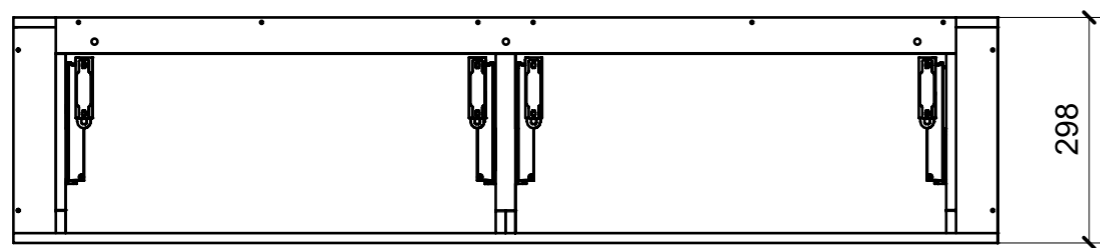

01

FERRAMENTA	QTY
CP BRACCIO PER ANTA A RIBALTA _HAFELE FREE SPACE 1.11_372_27_301	2

LOCALE	CODICE	DESCRIZIONE COMPONENTE	FINITURA	GR.
CABINA VIP	MD321_VQ01	MURATA DX	OKUME' GREZZO	2

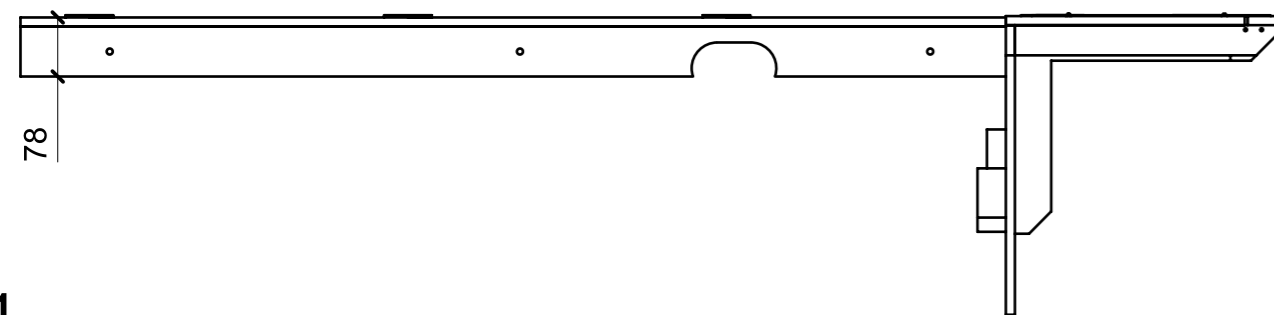
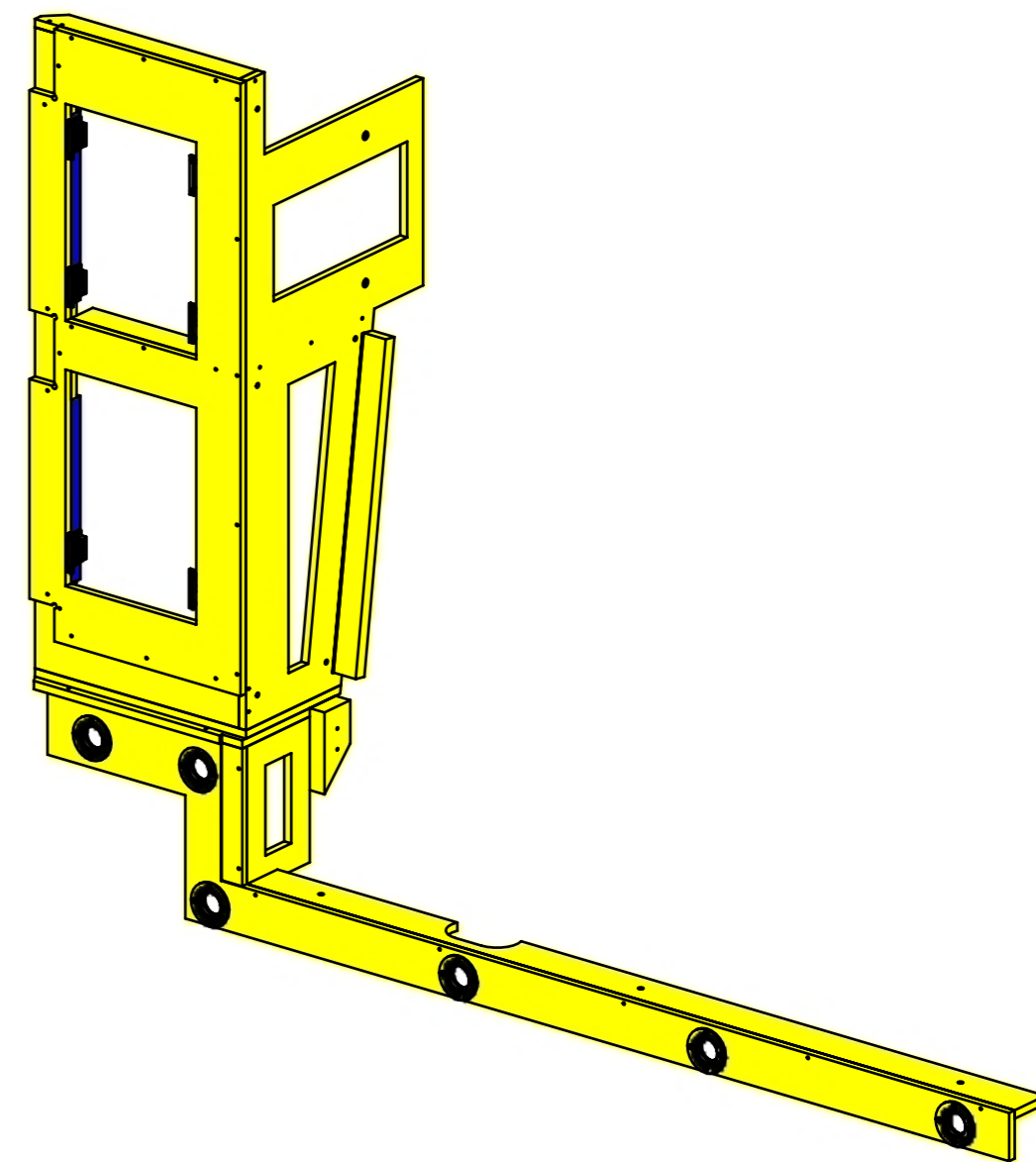
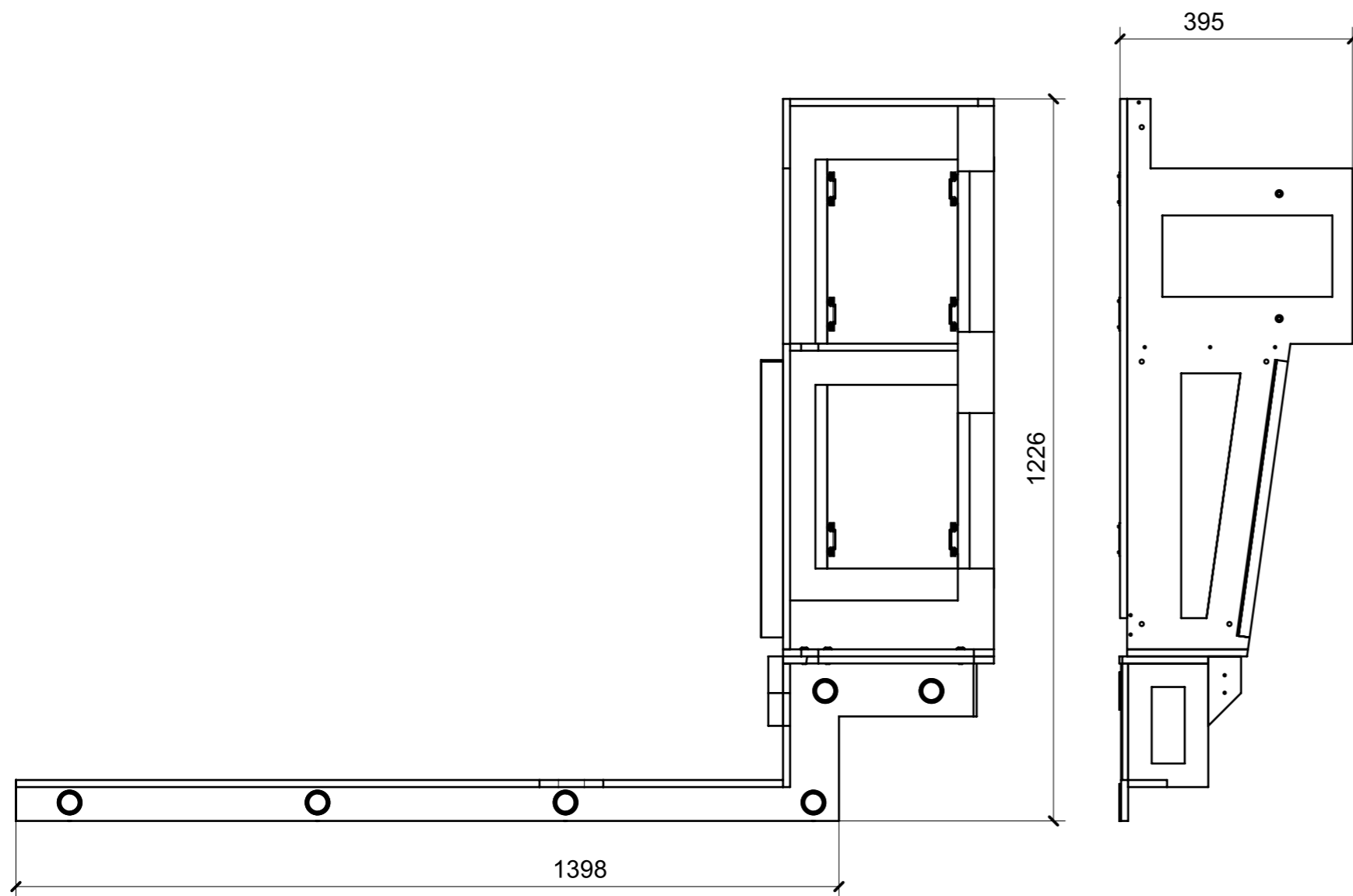

FERRAMENTA	QTY
CHIUSURA A SPINTA_TECHNOPARTNER_SOU C3-203	6
FITLOCK F_MASCHERPA_6020101102	6
VITE 6MA X 25 TESTA BOMBATA	3
BUSSOLA 6MA X 10 FORO DIAM.8	5

LOCALE	CODICE	DESCRIZIONE COMPONENTE	FINITURA	GR.
CABINA VIP	MD321_VR01	ARMADIO DX	LAMINATO SM'ART ES04 JUNGLE ANICE	2

ELEMENTI DA MONTARE  
in MG\_VR01  
e spedire con unico imballo

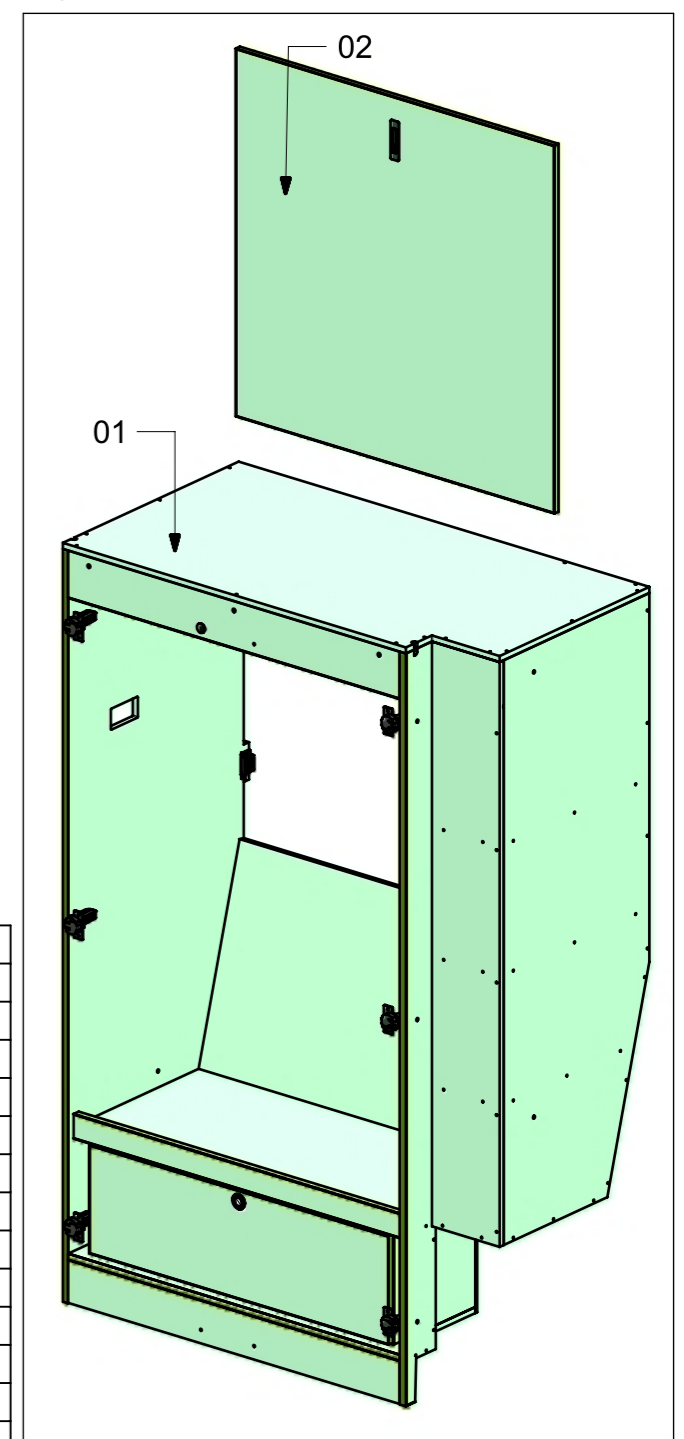
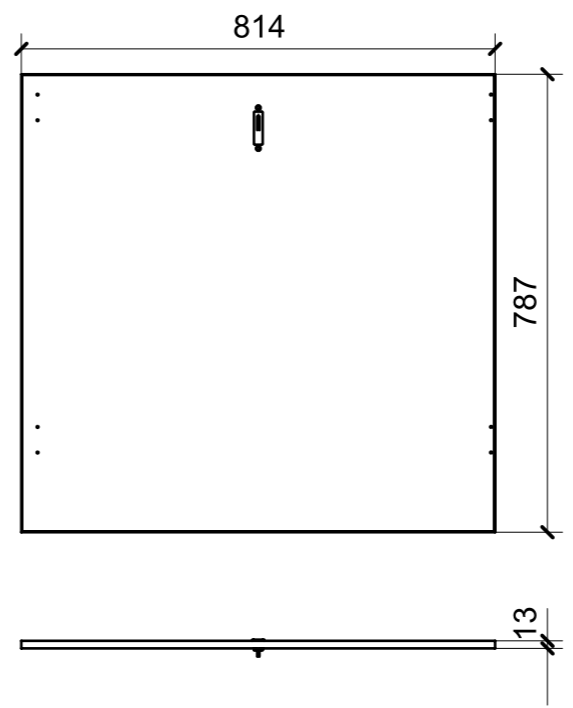
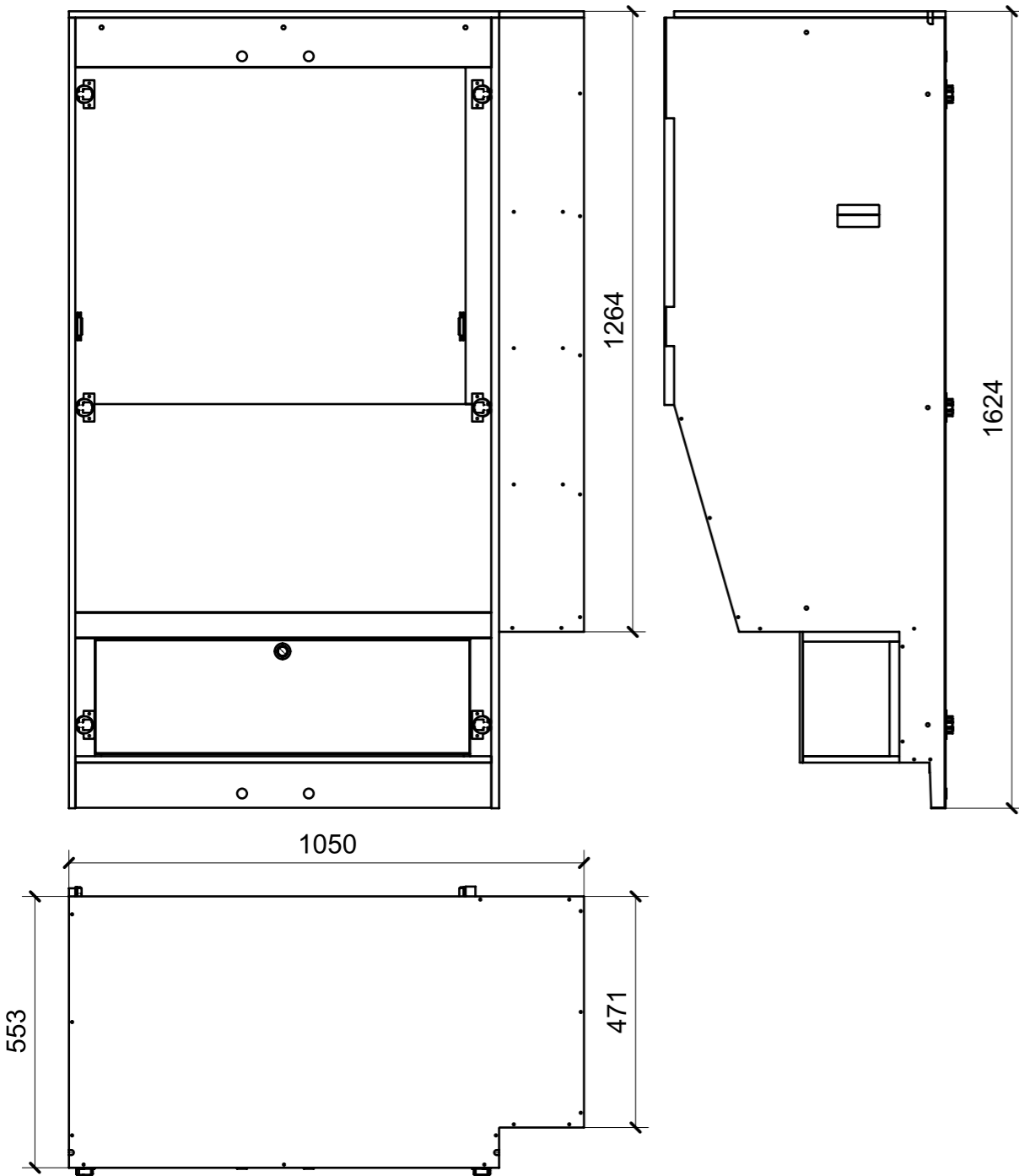

01

02

FERRAMENTA	QTY
RISCONTRO IN FERRO PER CALAMITA TONDO	4
ALZAPAGLIOLI_FORESTI_164.B BRUNITON	1
BASE_3-NERA_HAFELE_342.22.067-BLUM_175H3130.STP	6
BUSSOLA 5MA ANKOR BORGHI	12
BUSSOLA 6MA X 10 FORO DIAM.8	2
CERNIERA 94°_MEZZO COLLO-NERA_HAFELE_342.46.605-BLUM_71B9650	6
CHIUSURA A SPINTA_TECHNOPARTNER_SOU C3-203	6
GUIDA DYNAPRO ADJUSTAMENT ADAPTER L_FBC_F134141746 4D	1
GUIDA DYNAPRO ADJUSTAMENT ADAPTER R_FBC_F134141746 4D	1
GUIDA DYNAPRO FRONT LOCKING DEVICE L_FBC_F134108955 4D	1
GUIDA DYNAPRO FRONT LOCKING DEVICE R_FBC_F134108955 4D	1
GUIDA DYNAPRO SOFTCLOSE L250 L_FBC_F130107790 4D	1
GUIDA DYNAPRO SOFTCLOSE L250 R_FBC_F130107790 4D	1
KEEPER PUSH TO CLOSE_SOUTCHO-J-M1-519-4_TECHNOPARTNER	1
KIT BARRA APPENDIABITI - CP SUPPORTI+ BARRA	1
KIT LED PER ARMADIO MD321 VR01 MM 845_	1
PUSH TO CLOSE_SOUTHCO-MP-05-312-55 NERA_TECHNOPARTNER	1
RISCONTRO IN FERRO PER CALAMITA DA FAR PRODURRE X MD321	4
VITE 4MA X 12 TESTA SVASATA ESAGONALE NERA_FBC	2
VITE 4MAX8 ANKOR BORGHI	12

LOCALE	CODICE	DESCRIZIONE COMPONENTE	FINITURA	GR.
CABINA VIP	MD321_VS01	COLLEG. ARMADIO MURATA DX	OKUME' GREZZO	PTP

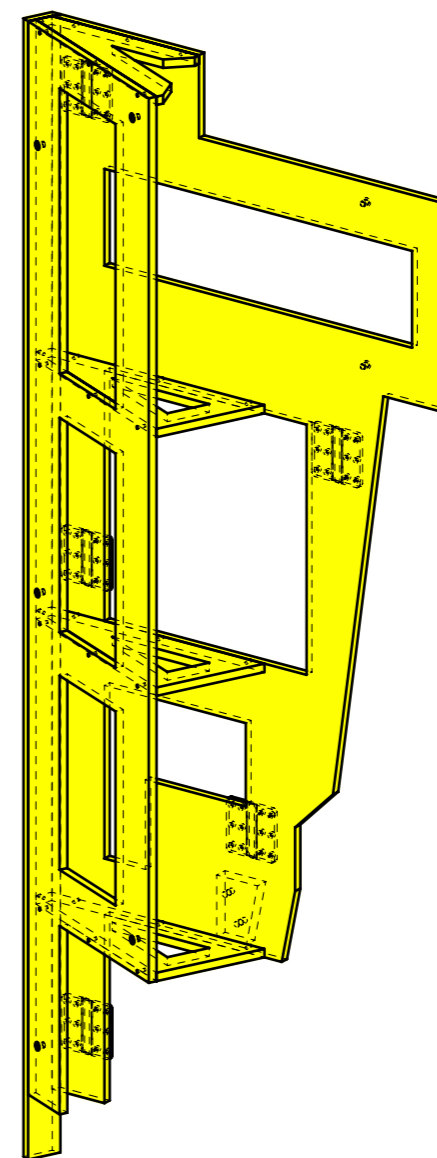
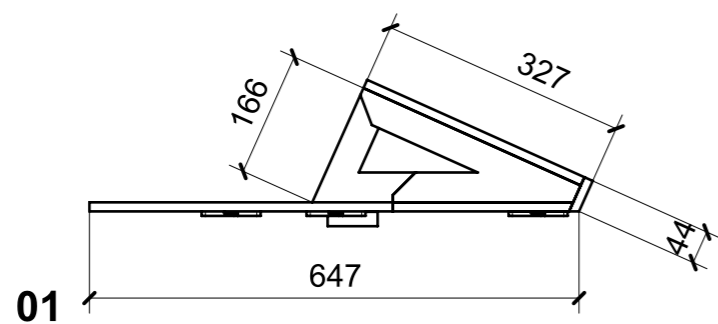
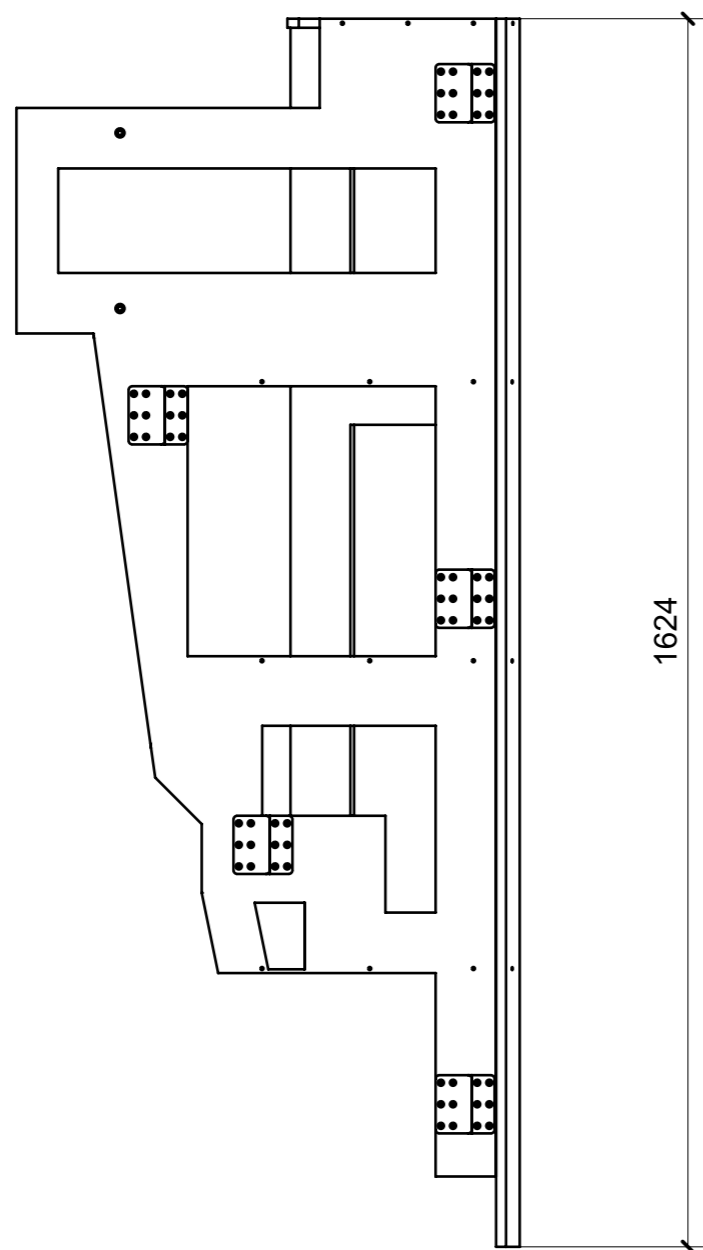

FERRAMENTA	QTY
BUSSOLA 6MA X 10 FORO DIAM.8	7
BAIONETTA CAI FITLOCK_	10

LOCALE	CODICE	DESCRIZIONE COMPONENTE	FINITURA	GR.
CABINA VIP	MD321_VZ01	SCURETTO CIELINO	LAM.SMART ES04 JUNGLE ANICE	PTP

