

LOCALE	CODICE	DESCRIZIONE COMPONENTE	FINITURA	GR.
CABINA ARMATORE	MD320_AA01	ARMADIO INGRESSO DX POPPA	LAMINATO SMART 0180-2 JUNGLE	4

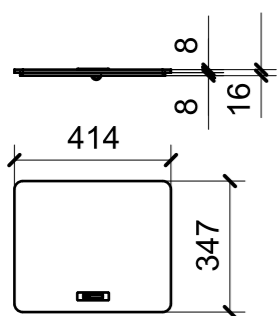

03

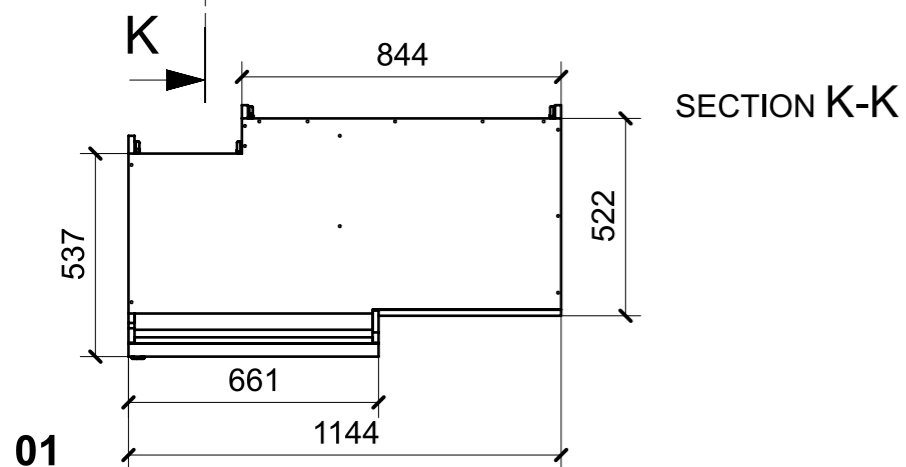
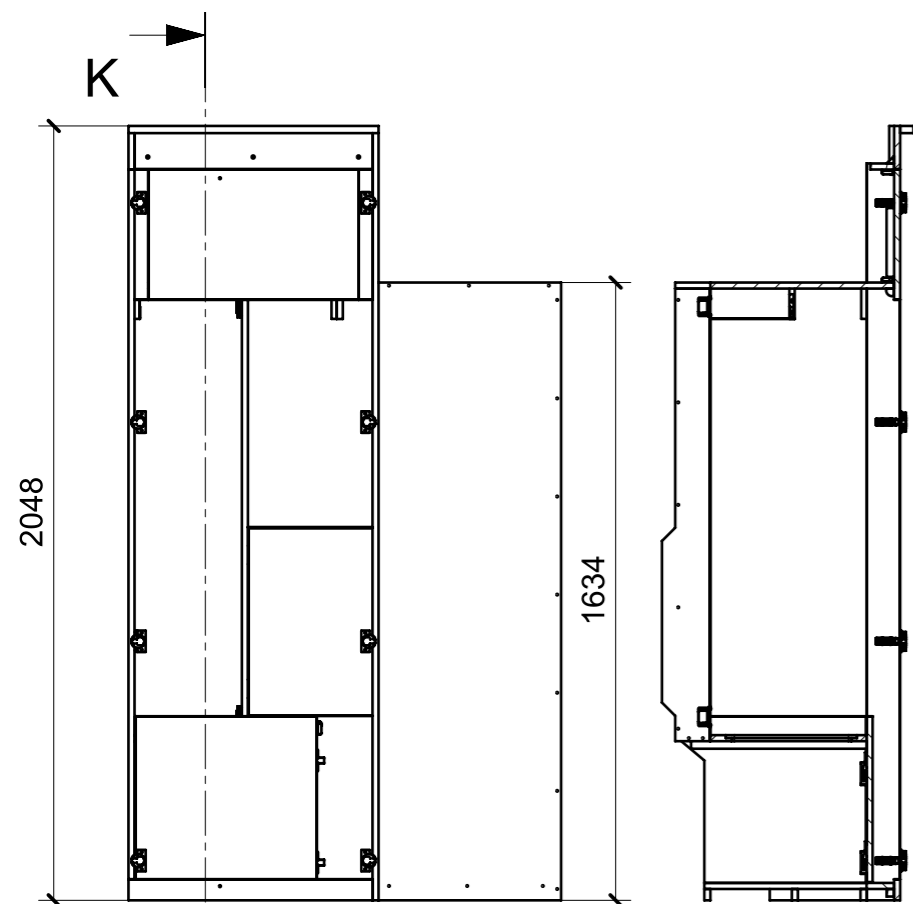
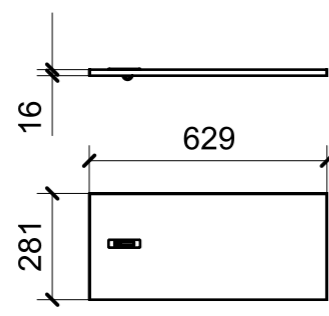

05

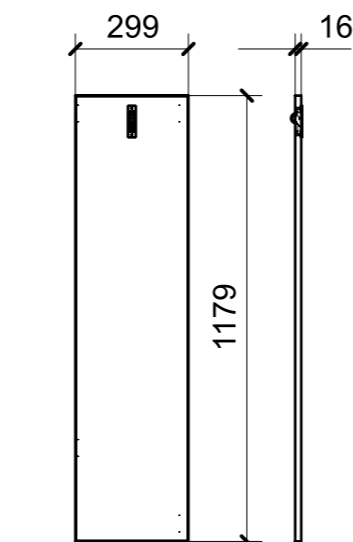

02

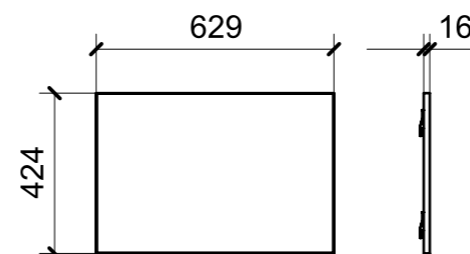

04

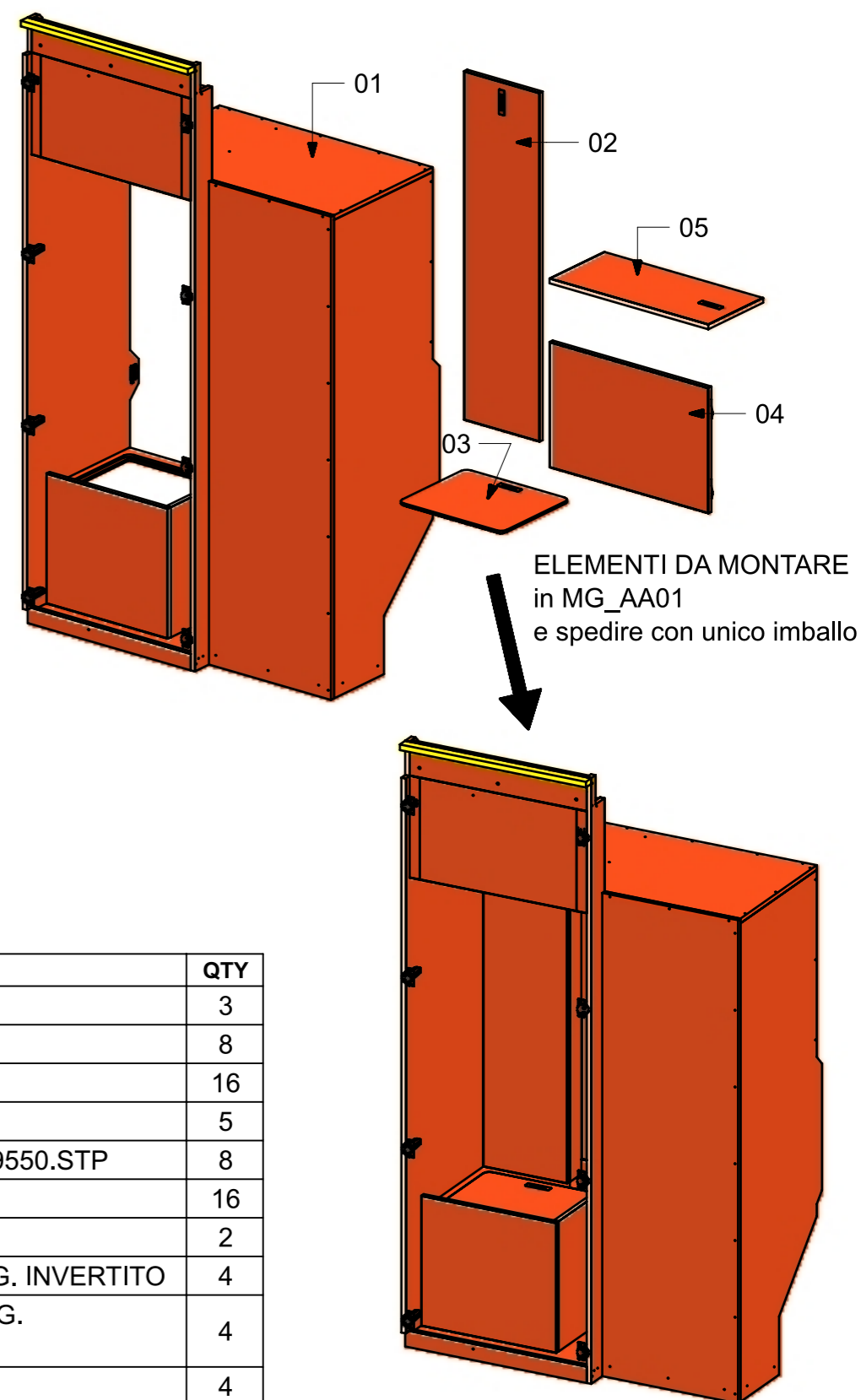

ELEMENTI DA MONTARE  
in MG\_AA01  
e spedire con unico imballo

FERRAMENTA	QTY
ALZAPAGLIOLI_FORESTI_164.B BRUNITON	3
BASE_3-NERA_HAFELE_342.22.067-BLUM_175H3130.STP	8
BUSSOLA 5MA ANKOR BORGHI	16
BUSSOLA 6MA X 10 FORO DIAM.8	5
CERNIERA 94°_PIANA-NERA_HAFELE_342.46.604-BLUM_71B9550.STP	8
CHIUSURA A SPINTA_TECHNOPARTNER_SOU C3-203	16
KIT BARRA APPENDIABITI - CP SUPPORTI+ BARRA	2
PARTE PANNELLO CON INCASTRO_HAFELE_262_49_356 AGG. INVERTITO	4
PARTE PANNELLO CON INCASTRO_HAFELE_262_49_356 AGG. RIBALTATO	4
PARTE TELAIO EHS_HAFELE_262_49_365 AGG. INVERTITO	4
PARTE TELAIO EHS_HAFELE_262_49_367 AGG. RIBALTATO	4
VITE 4MA X 10 TESTA SVASATA ESAGONALE NERA	6
VITE 4MAX8 ANKOR BORGHI	16

LOCALE	CODICE	DESCRIZIONE COMPONENTE	FINITURA	GR.
CABINA ARMATORE	MD320_AB01	ARMADIO INGRESSO SX POPPA	LAMINATO SMART 0180-2 JUNGLE	4

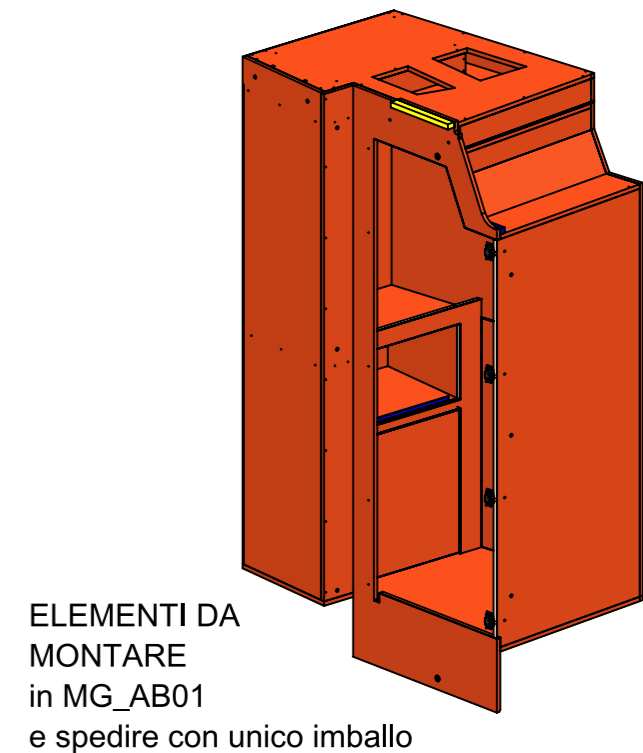
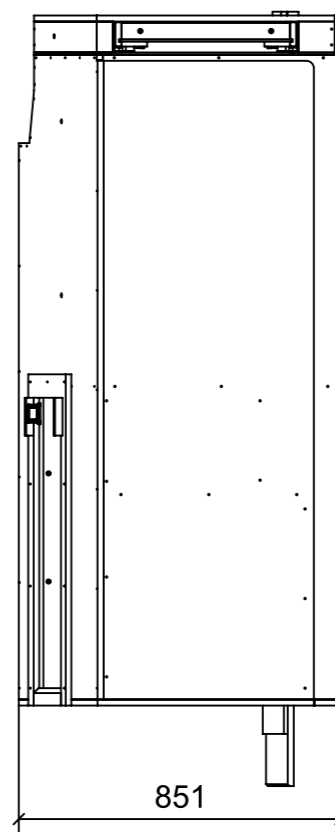
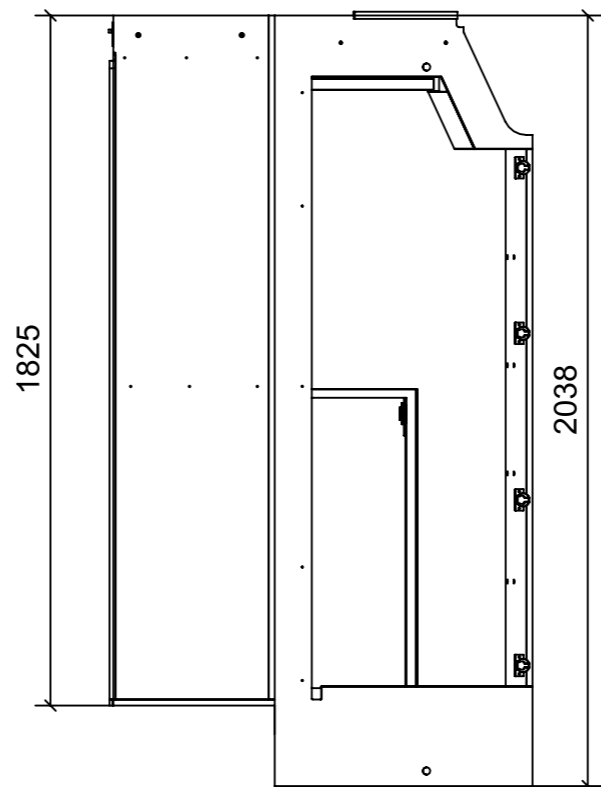
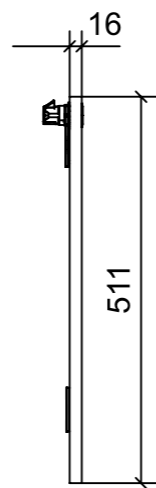
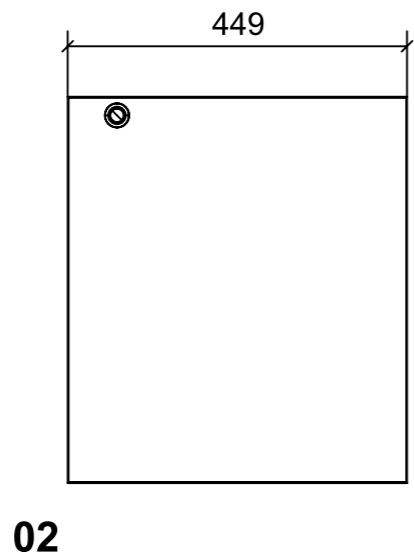

01

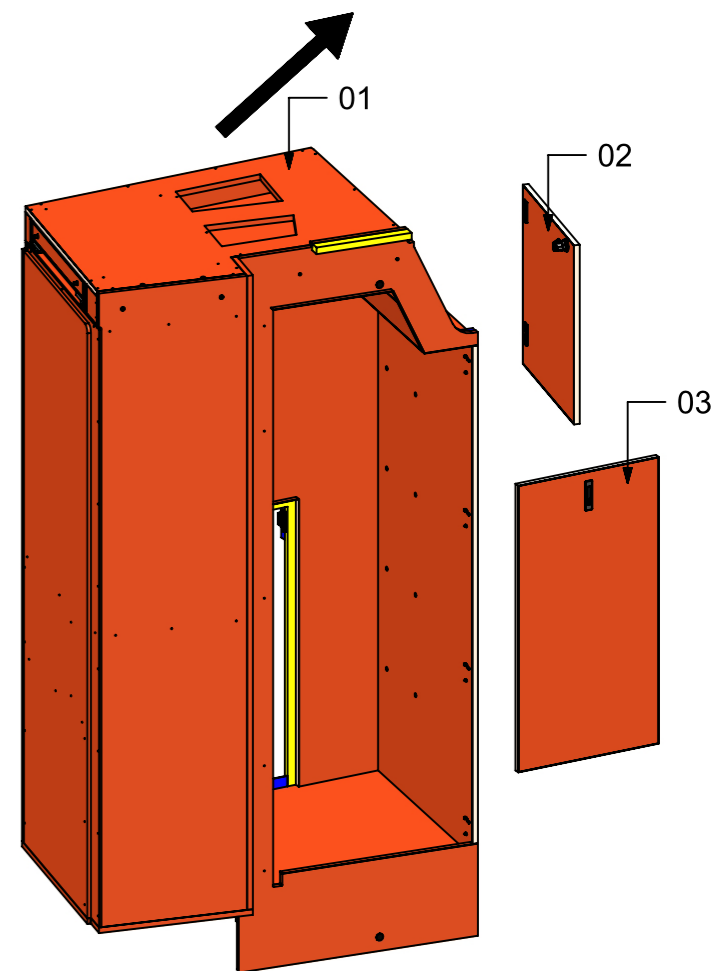
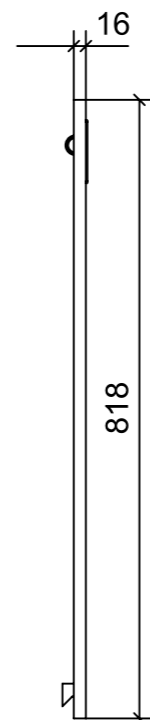
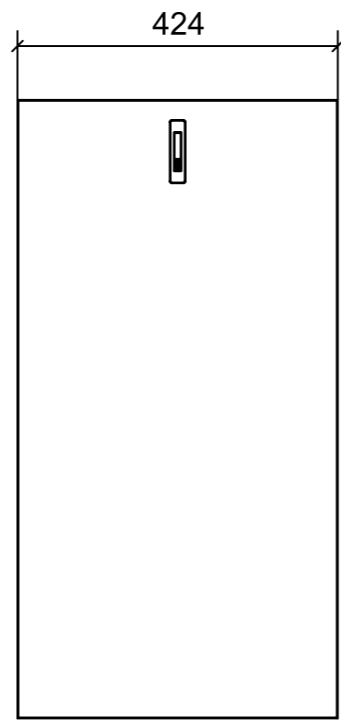

FERRAMENTA	QTY
CERNIERA 94°_PIANA-NERA_HAFELE_342.46.604-BLUM_71B9550.STP	4
BASE_3-NERA_HAFELE_342.22.067-BLUM_175H3130.STP	4
VITE 4MAX8 ANKOR BORGHI	8
BUSSOLA 5MA ANKOR BORGHI	10
RISCONTRO IN FERRO PER CALAMITA TONDO	2
BUSSOLA 6MA X 10 FORO DIAM.8	27
ALZAPAGLIOLI_FORESTI_164.B BRUNITON	1
BASE_0-NERA_HAFELE_342.22.065-BLUM_175H3100.STP	2
BUSSOLA 5MA ANKOR BORGHI X BASE 0	4
BUSSOLA 5MA ANKOR BORGHI X CERNIERA COLLO PIENO	4
CERNIERA 95°_COLLO PIENO-NERA_HAFELE_342.46.606-BLUM_71B9750.STP	2
CHIUSURA A SPINTA_TECHNOPARTNER_SOU C3-203	2
COPERTURA BRACCIO CERNIERA MEZZO COLLO NERO-HAFELE_342.94.634-BLUM_70.1663	2
COPERTURA GABBIA CERNIERA NERO_HAFE_342.45.032-BLUM_70T3504.STP	2
GUIDA DYNAPRO ADJUSTAMENT ADAPTER L_FBC_F134141746 4D	1
GUIDA DYNAPRO ADJUSTAMENT ADAPTER R_FBC_F134141746 4D	1
GUIDA DYNAPRO FRONT LOCKING DEVICE L_FBC_F134108955 4D	1
GUIDA DYNAPRO FRONT LOCKING DEVICE R_FBC_F134108955 4D	1
GUIDA DYNAPRO SOFTCLOSE L350 L_FBC_F130107802 4D	1
GUIDA DYNAPRO SOFTCLOSE L350 R_FBC_F130107802 4D	1
KEEPER PUSH TO CLOSE_SOUTCHO-J-M1-519-4_TECHNOPARTNER	1
KIT BARRA APPENDIABITI - BARRA_AB01_851_MM_HAFELE_801_83_003	1
KIT BARRA APPENDIABITI - CP SUPPORTI+ BARRA	1
KIT LED PER ARMADIO MD320 AB01 MM 875_	1
PUSH TO CLOSE_SOUTHCO-MP-05-312-55 NERA_TECHNOPARTNER	1
VITE 4MA X 10 TESTA SVASATA ESAGONALE NERA	2
VITE 4MAX8 ANKOR BORGHI X BASE 0	4
VITE 4MAX8 ANKOR BORGHI X CERNIERA COLLO PIENO	12
VITE 6MA X 20 TESTA BOMBATA	4
VITE 6MA X 25 TESTA SVASATA	2

LOCALE	CODICE	DESCRIZIONE COMPONENTE	FINITURA	GR.
CABINA ARMATORE	MD320_AC01	MURATA DX POPPA	OKOUME' GREZZO	2

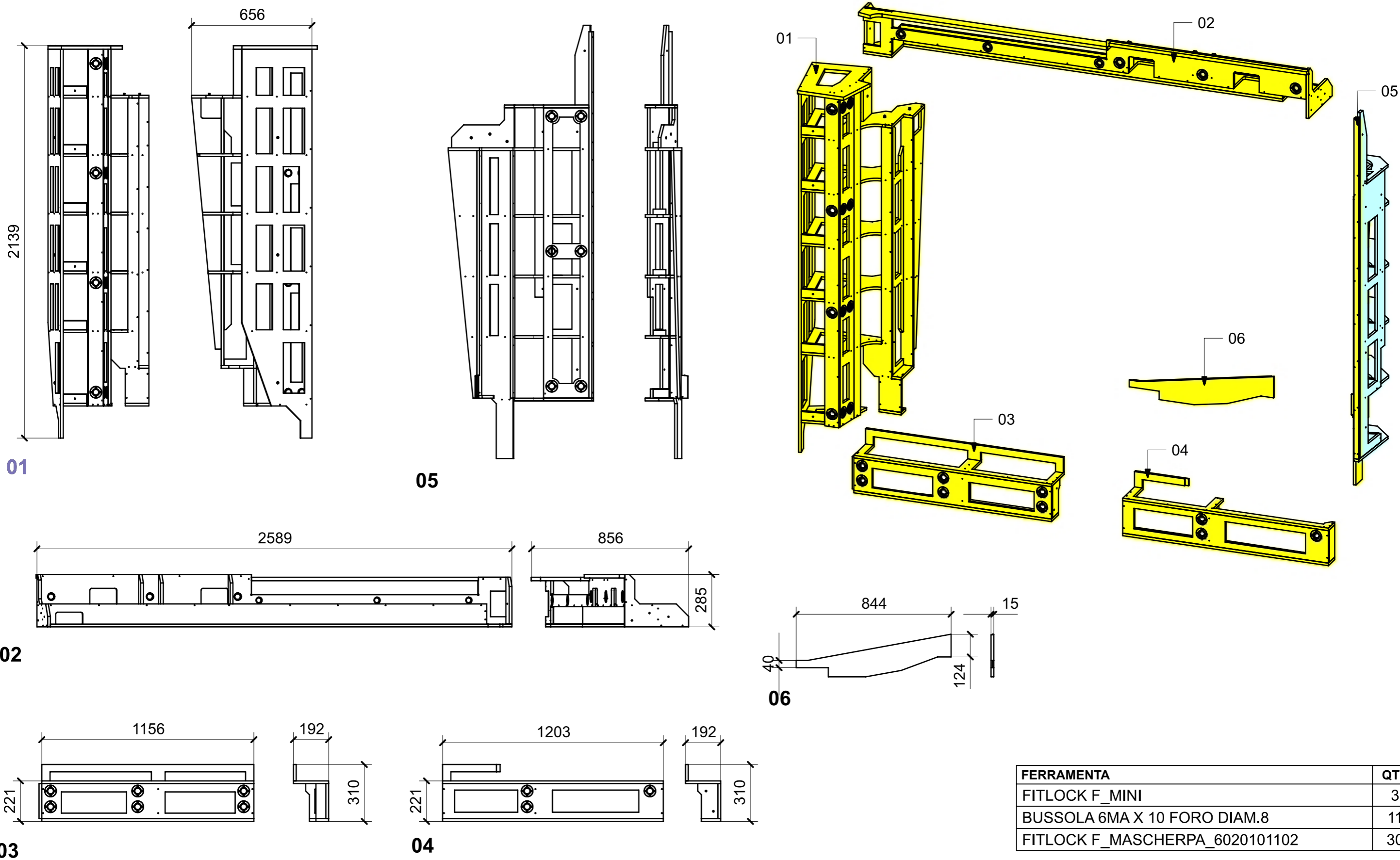

LOCALE	CODICE	DESCRIZIONE COMPONENTE	FINITURA	GR.
CABINA ARMATORE	MD320_AD01	MURATA SX POPPA	OKOUME' GREZZO	2

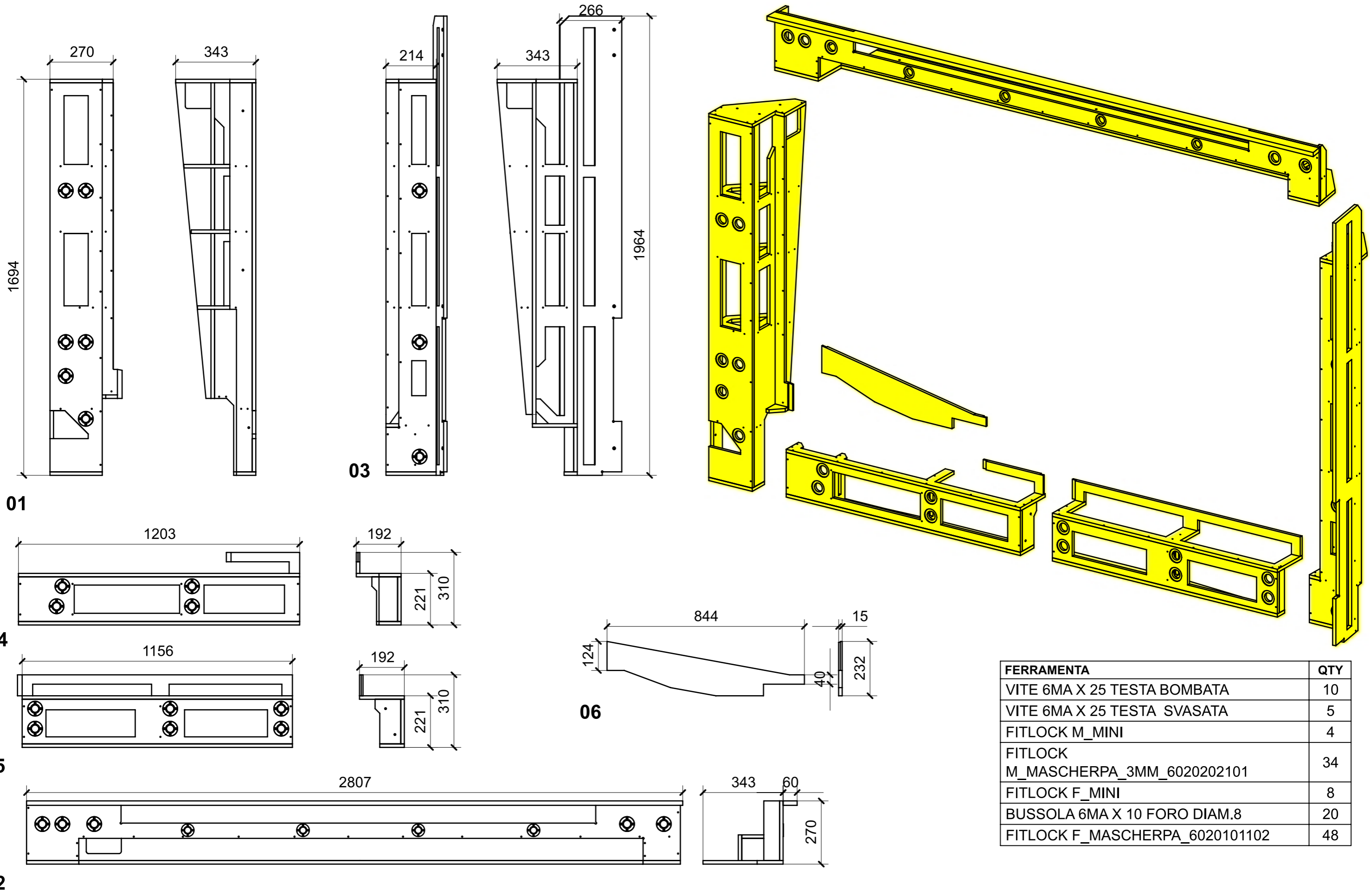

FERRAMENTA	QTY
VITE 6MA X 25 TESTA BOMBATA	10
VITE 6MA X 25 TESTA SVASATA	5
FITLOCK M_MINI	4
FITLOCK M_MASCHERPA_3MM_6020202101	34
FITLOCK F_MINI	8
BUSSOLA 6MA X 10 FORO DIAM.8	20
FITLOCK F_MASCHERPA_6020101102	48

LOCALE	CODICE	DESCRIZIONE COMPONENTE	FINITURA	GR.
CABINA ARMATORE	MD320_AE01	PARETE TV CENTRO NAVE	OKOUME' GREZZO\ SPRUZZATO NERO	PTP

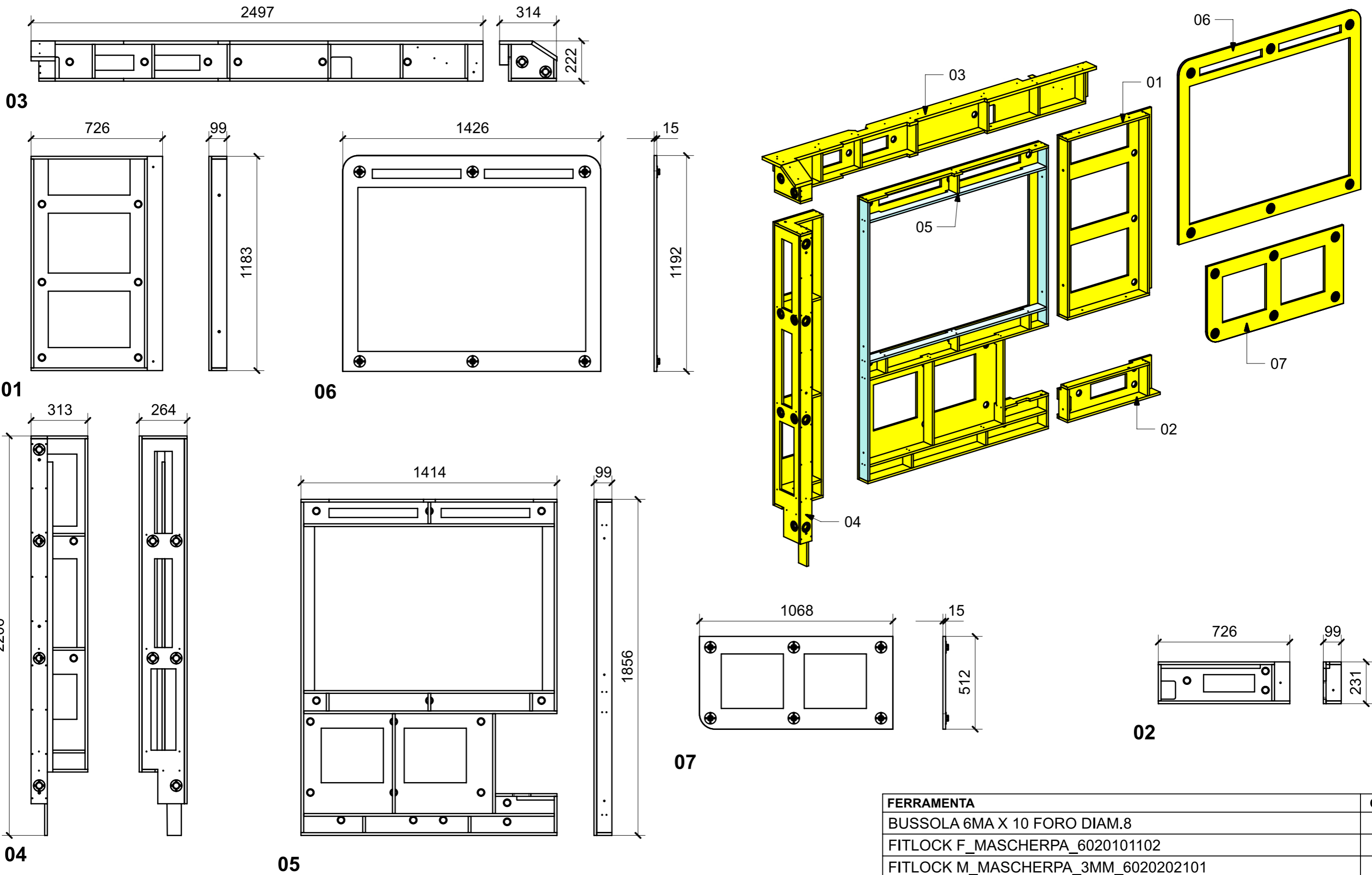

FERRAMENTA	QTY
BUSSOLA 6MA X 10 FORO DIAM.8	17
FITLOCK F_MASCHERPA_6020101102	48
FITLOCK M_MASCHERPA_3MM_6020202101	12

VERNICIATURA LASTRA/LACCATI:

● = FILI RASATI

● = VERNICIARE 1 LATO + FILI RASATI O BORDATI

NESSUN SIMBOLO = VERNICIARE 2 LATI + FILI RASATI O BORDATI

LOCALE	CODICE	DESCRIZIONE COMPONENTE	FINITURA	GR.
CABINA ARMATORE	MD320_AF01	MOBILE SOSPESO ZONA TV	LAMINATO SMART 0180-2 JUNGLE	4

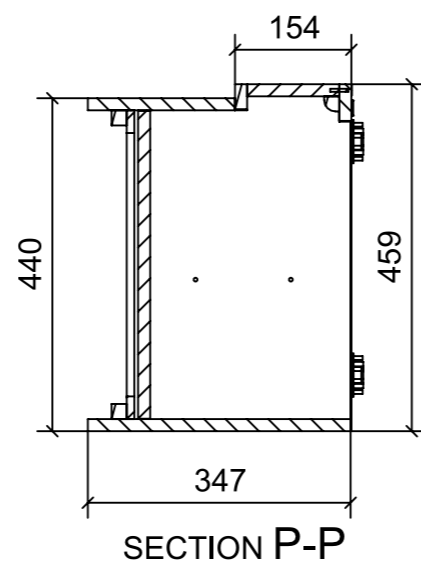
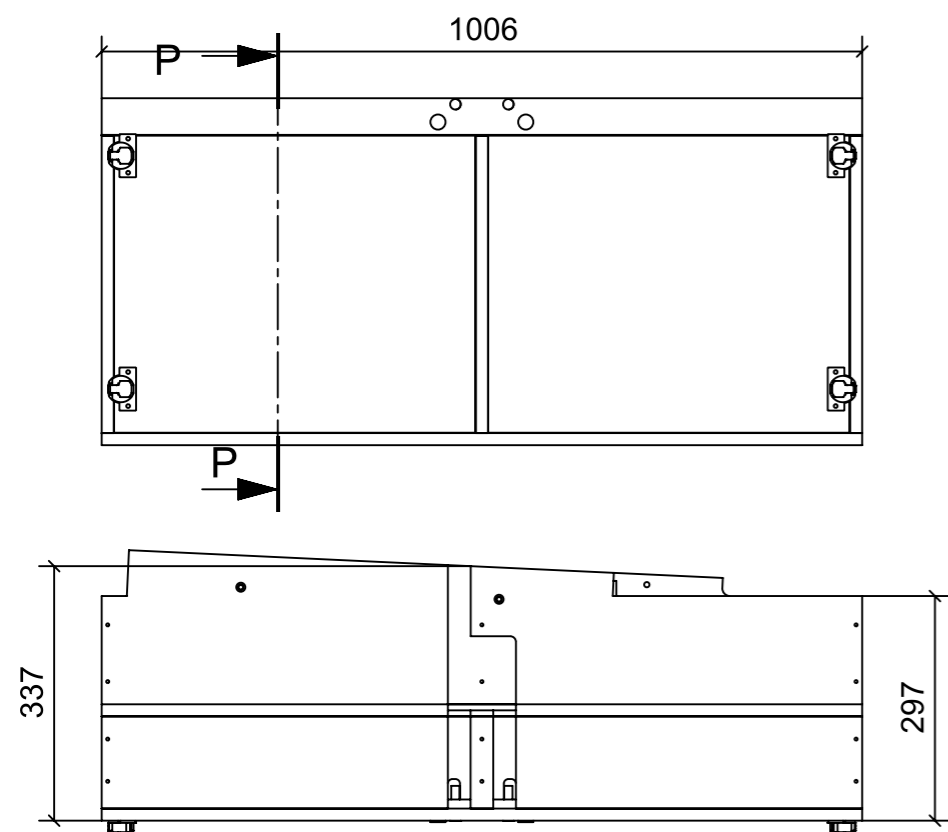

01

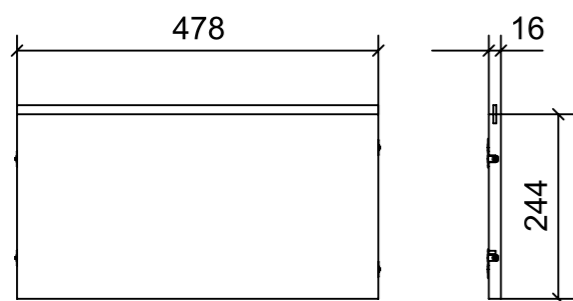

02

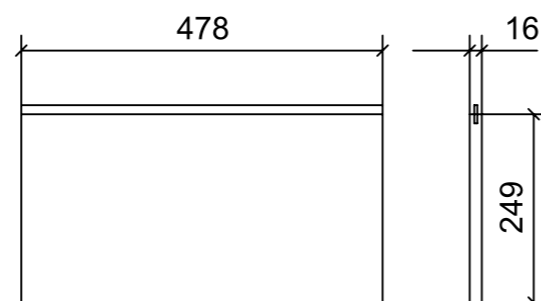

04

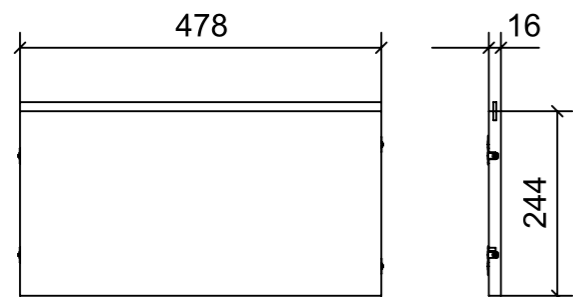

03

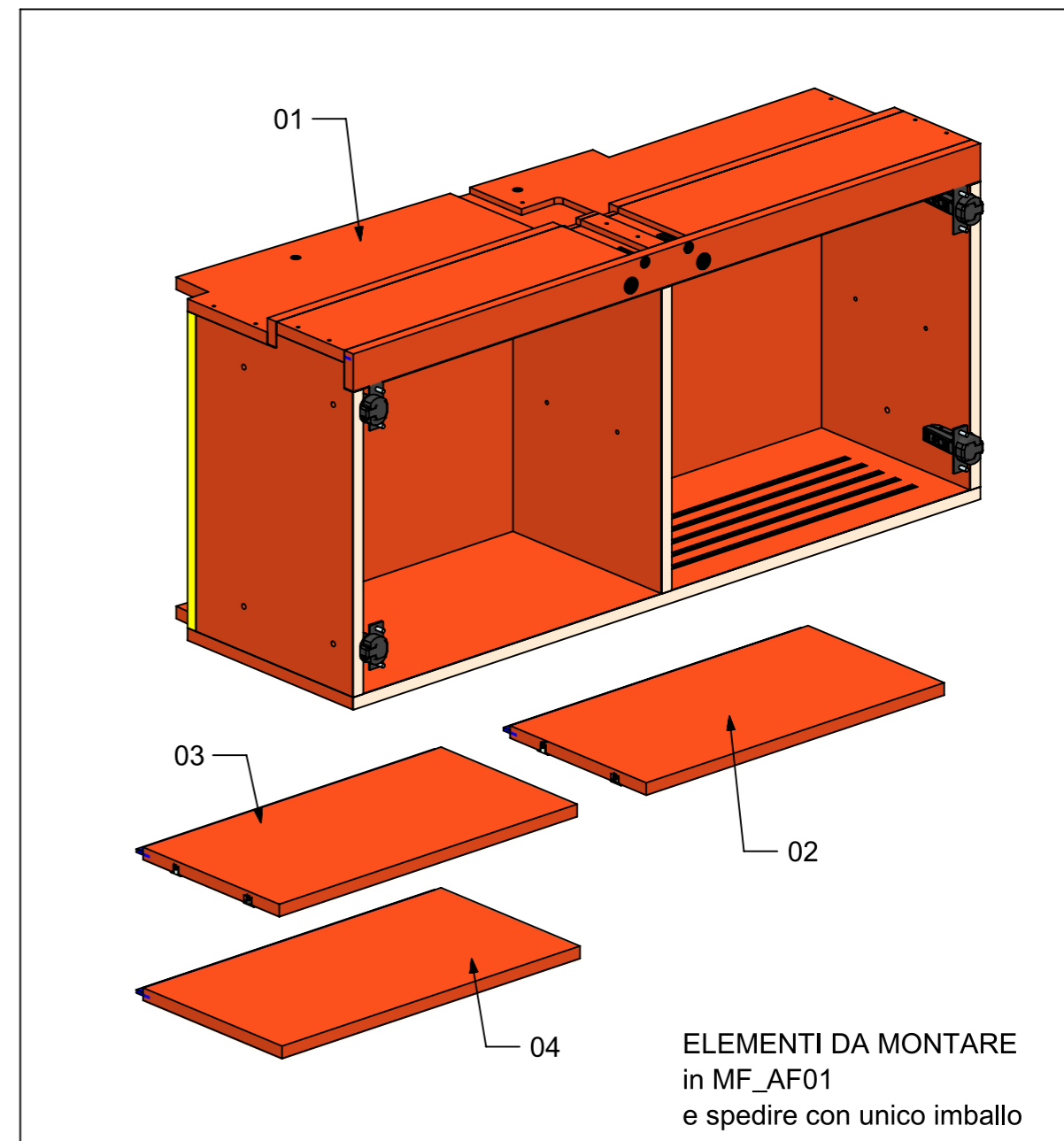

FERRAMENTA	QTY
CERNIERA 94°_PIANA-NERA_HAFELE_342.46.604-BLUM_71B9550.STP	4
BASE_3-NERA_HAFELE_342.22.067-BLUM_175H3130.STP	4
VITE 4MAX8 ANKOR BORGHI	8
BUSSOLA 5MA ANKOR BORGHI	10
BUSSOLA 6MA X 10 FORO DIAM.8	2
GIUNTO REGGIRIPIANO_HAFELE_262.36.510	8
KIT LED PER ARMADIO MD320 AF01 MM 478_	2
RISCONTRO IN FERRO PER CALAMITA TONDO	2
SENSORE RETROANTA_HAFELE_833_89_334	2

LOCALE	CODICE	DESCRIZIONE COMPONENTE	FINITURA	GR.
CABINA ARMATORE	MD320_AG01	TESTATA LETTO	OKOUME' GREZZO\ CARTA MELAMINICA NERA	3

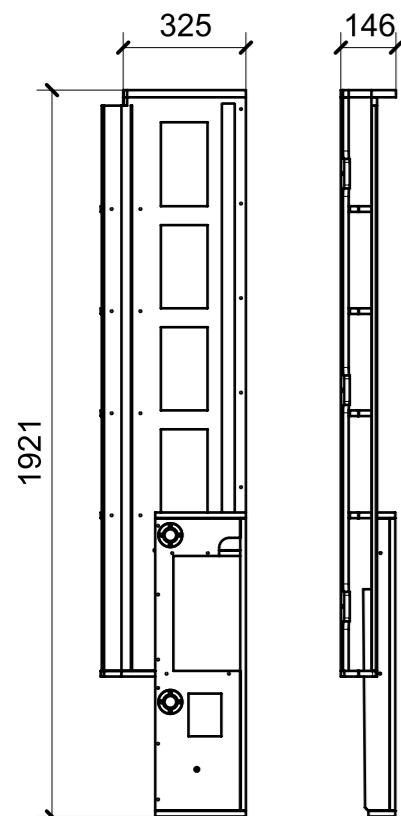

01

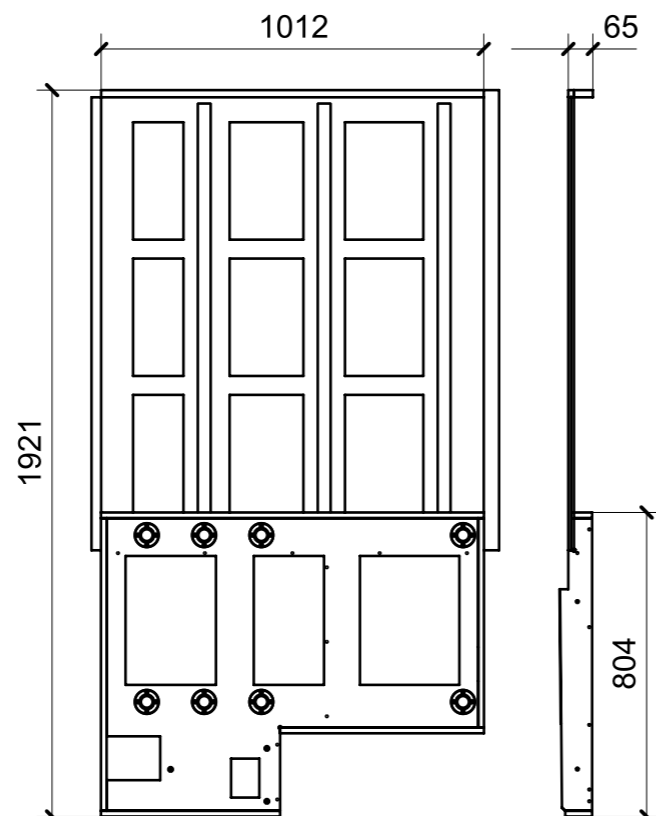

02

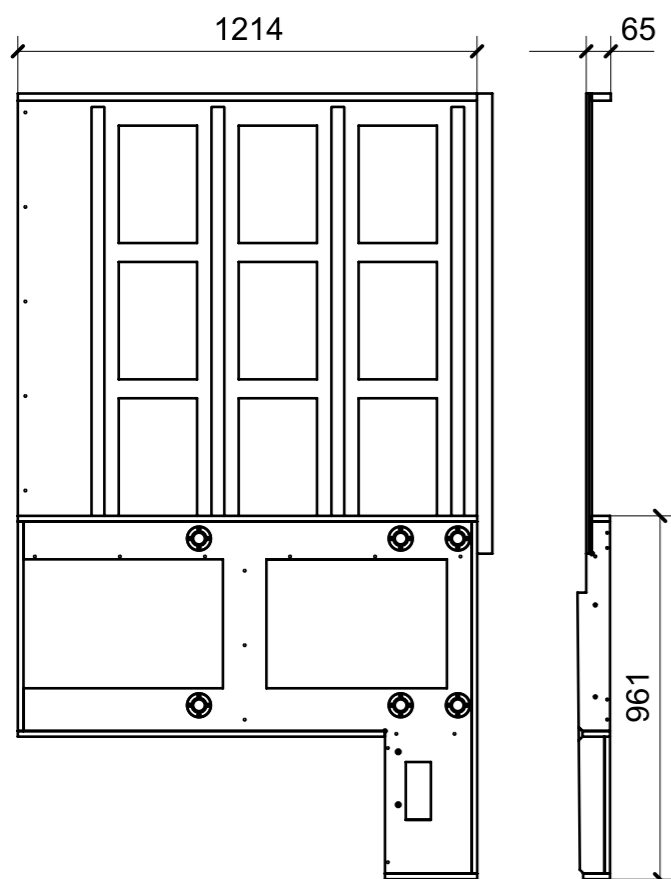

03

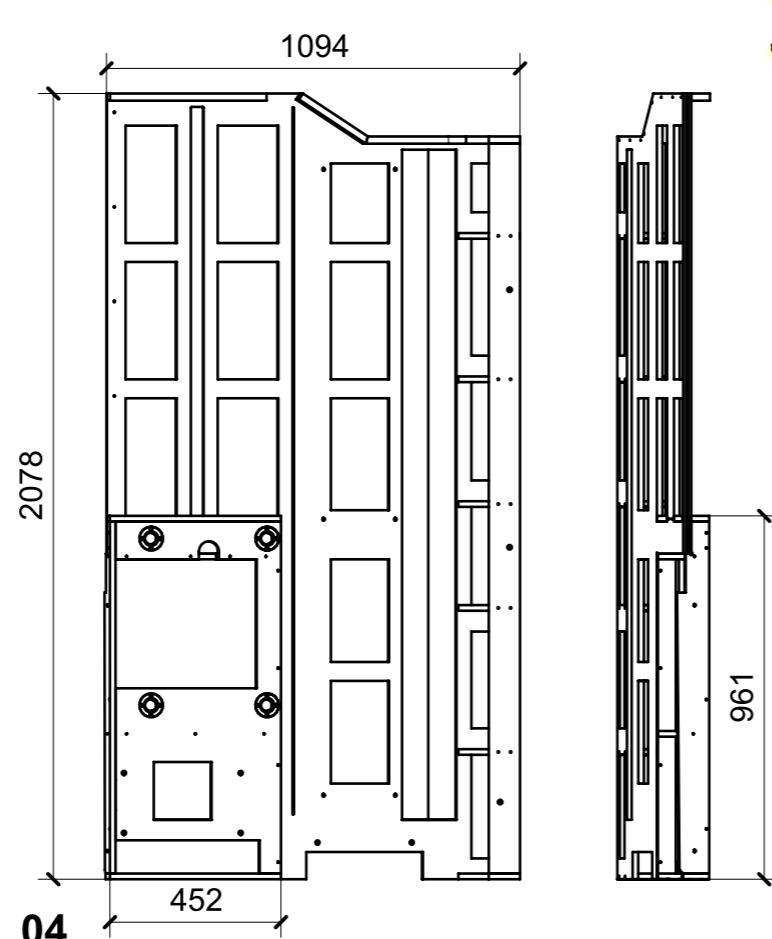

04

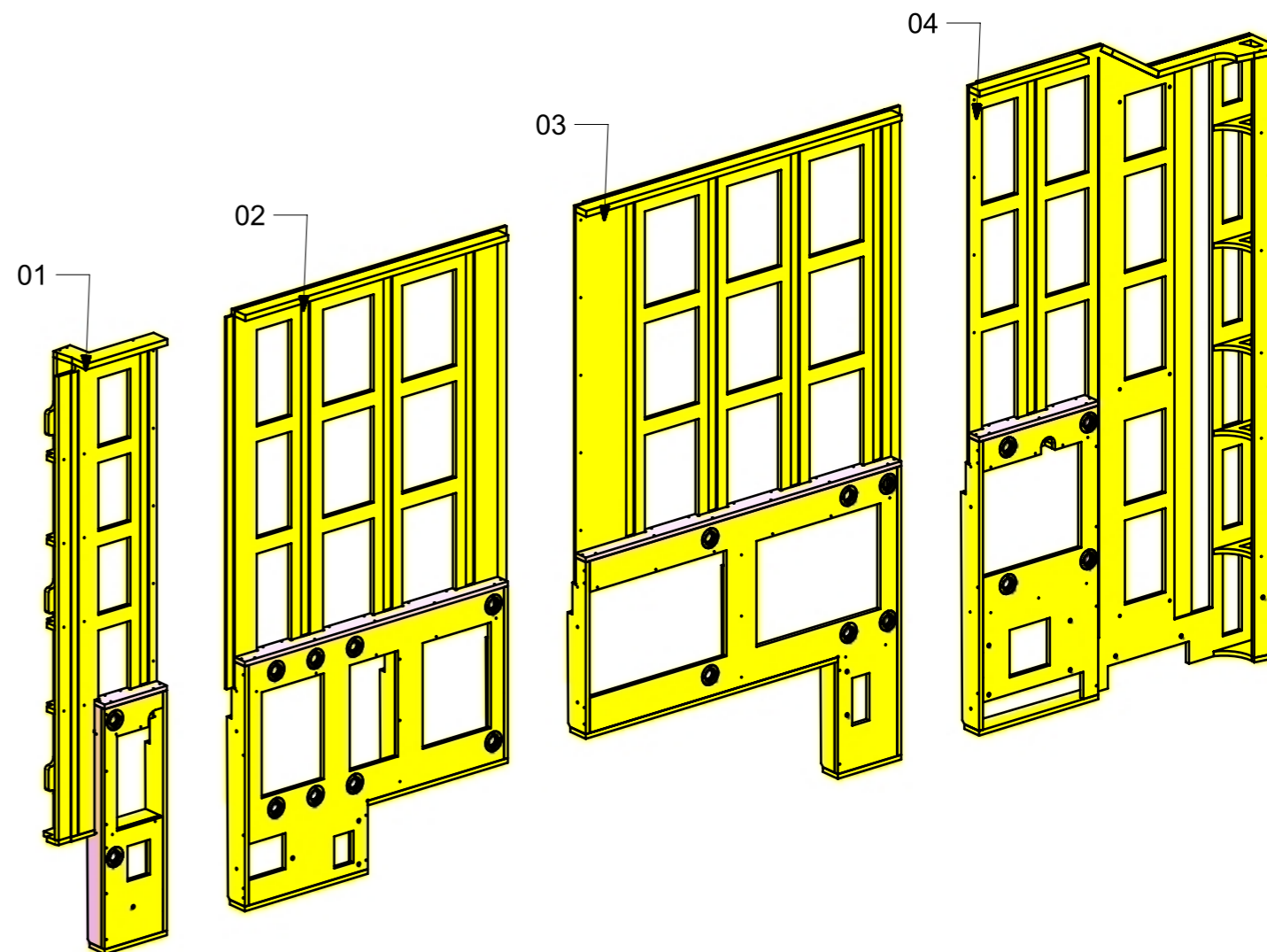

FERRAMENTA	QTY
FITLOCK F_MASCHERPA_6020101102	20
BUSSOLA 6MA X 10 FORO DIAM.8	21

LOCALE	CODICE	DESCRIZIONE COMPONENTE	FINITURA	GR.
CABINA ARMATORE	MD320_AH01	COMODINO SX	LAMINATO SMART 0180-2 JUNGLE	4

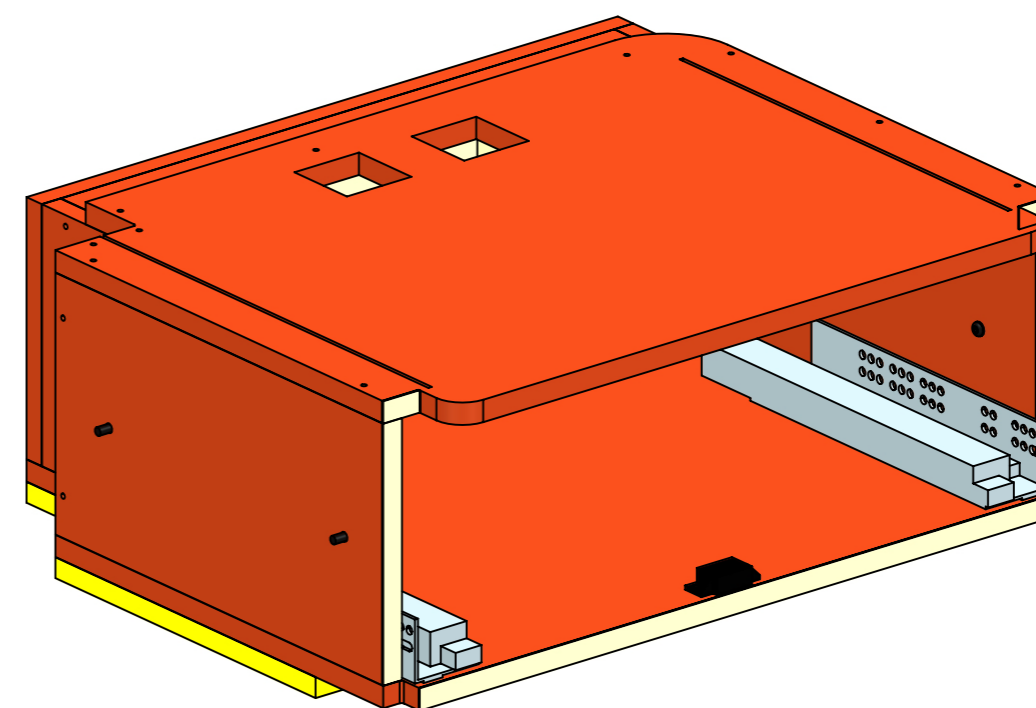
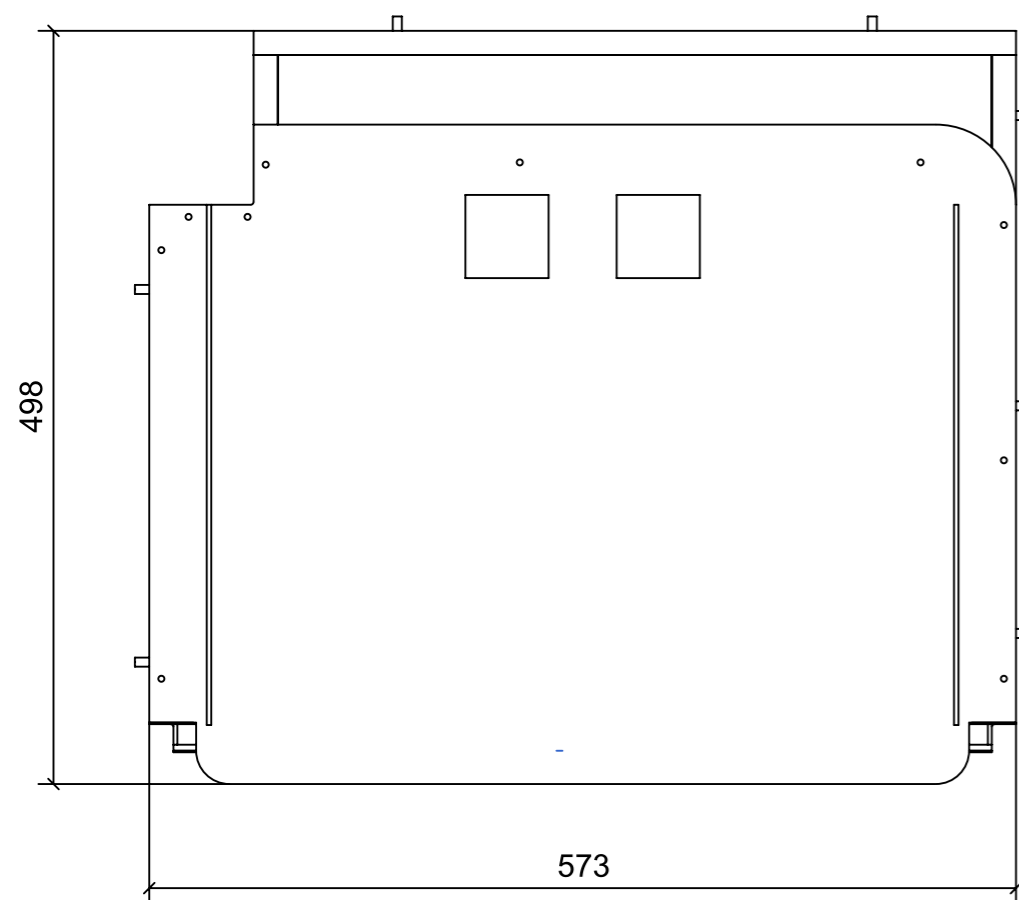
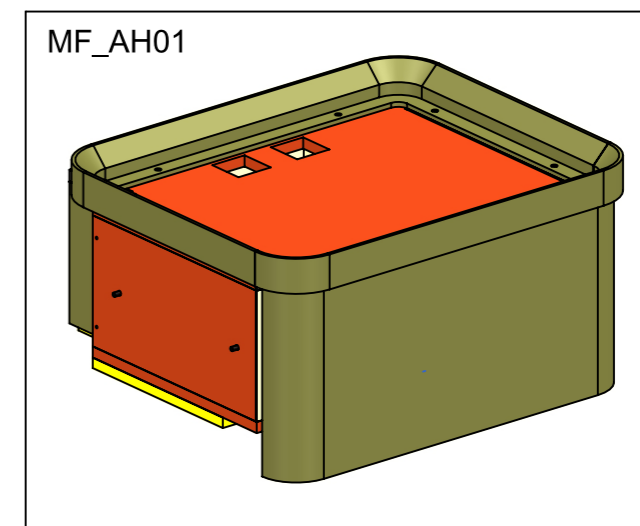
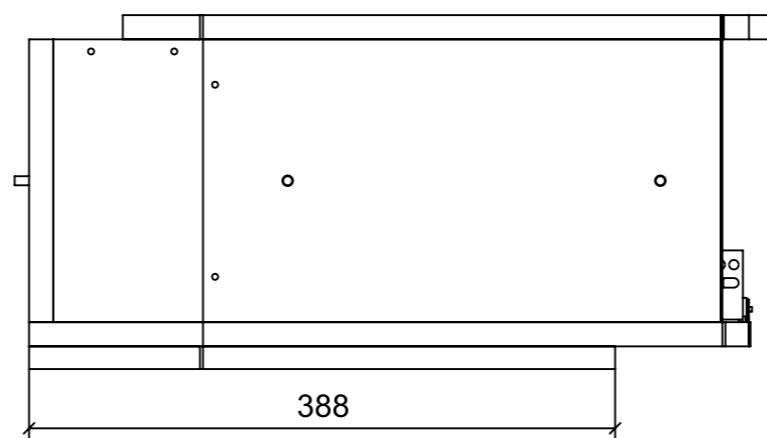
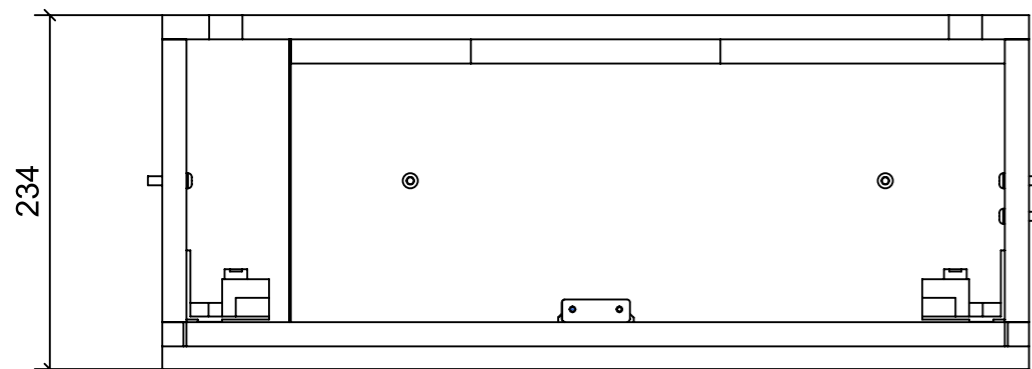

FERRAMENTA	QTY
PLACCHETTA COUNTER STEEL_TECHNOPARTNER_MC-JM49	1
VITE 6MA X 25 TESTA BOMBATA NERA BHCS 10.9 ISO 7380	7
GUIDA DYNAPRO SOFTCLOSE L300 R_FBC_F130107796 4D	1
CALAMITA SEALED MAGNETIC_TECNOPARTNER_MC-JM50-BL	1
GUIDA DYNAPRO SOFTCLOSE L300 L_FBC_F130107796 4D	1

LOCALE	CODICE	DESCRIZIONE COMPONENTE	FINITURA	GR.
CABINA ARMATORE	MD320_AI01	COMODINO DX	LAMINATO SMART 0180-2 JUNGLE	4

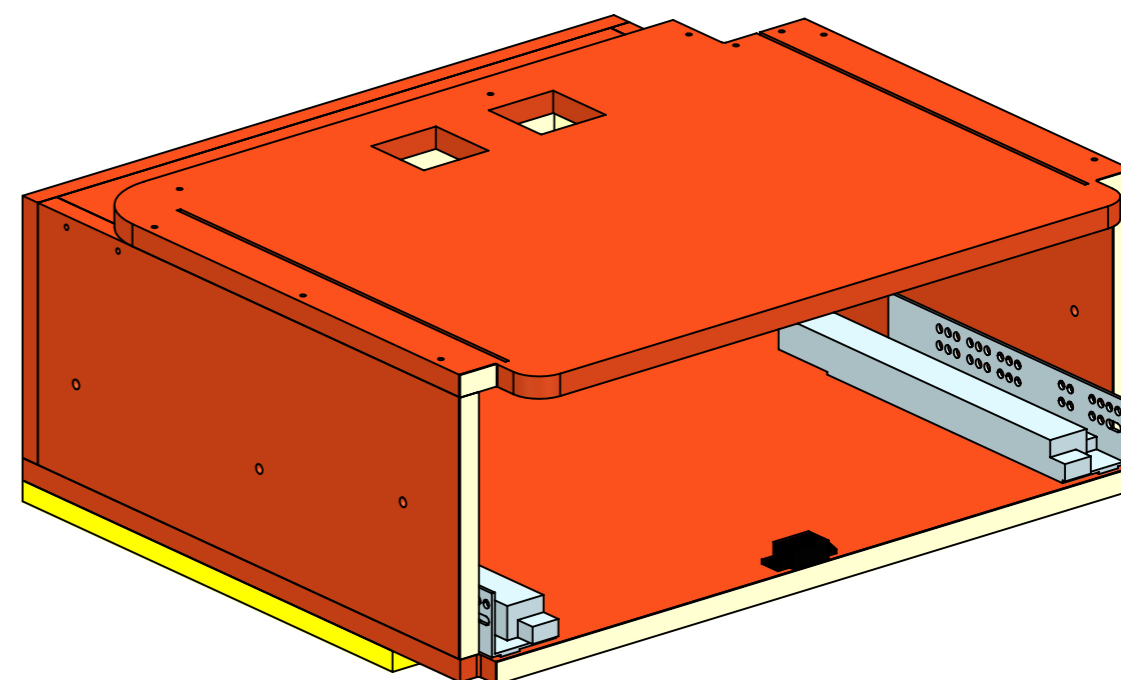
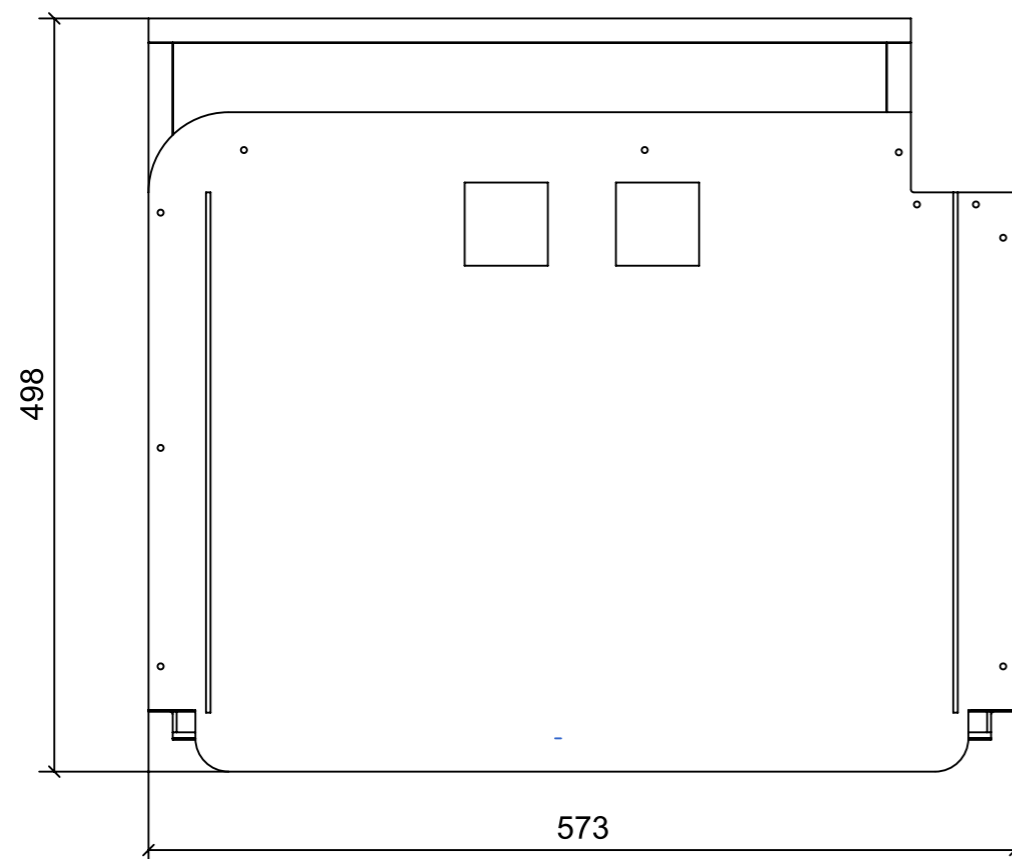
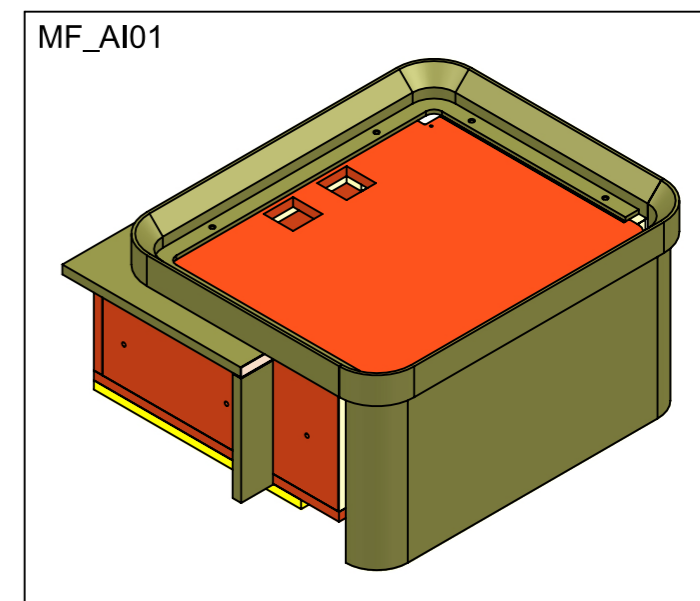
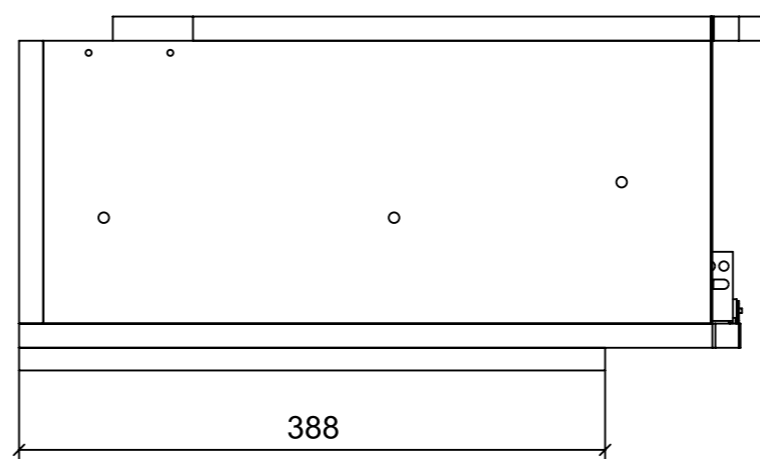
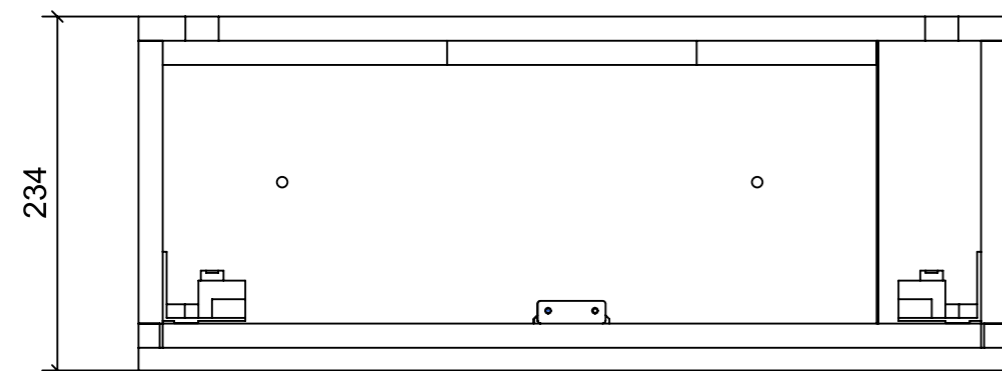

FERRAMENTA	QTY
PLACCHETTA COUNTER STEEL_TECHNOPARTNER_MC-JM49	1
GUIDA DYNAPRO SOFTCLOSE L300 R_FBC_F130107796 4D	1
GUIDA DYNAPRO SOFTCLOSE L300 L_FBC_F130107796 4D	1
CALAMITA SEALED MAGNETIC_TECNOPARTNER_MC-JM50-BL	1

LOCALE	CODICE	DESCRIZIONE COMPONENTE	FINITURA	GR.
CABINA ARMATORE	MD320_AJ01	CIELINO INGRESSO	CARTA MELAMINICA NERA	3

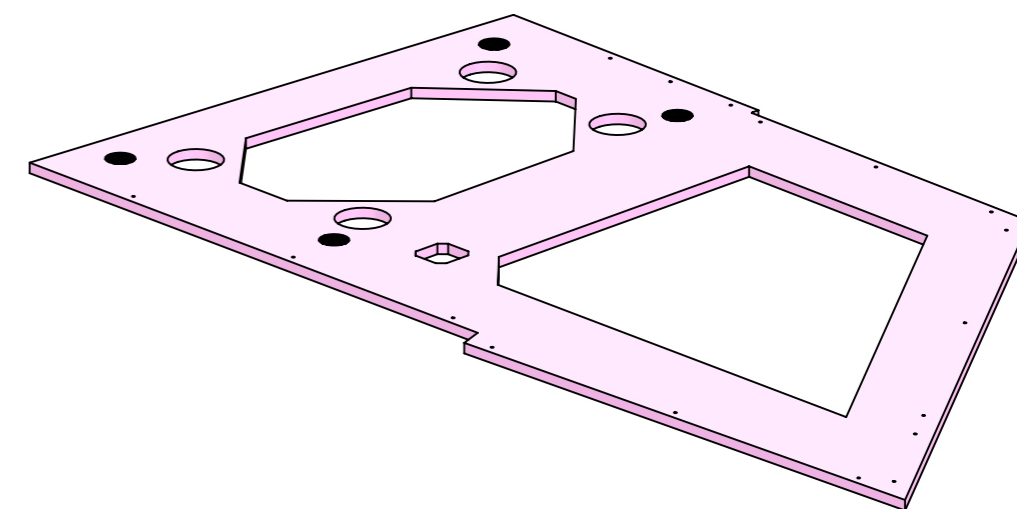
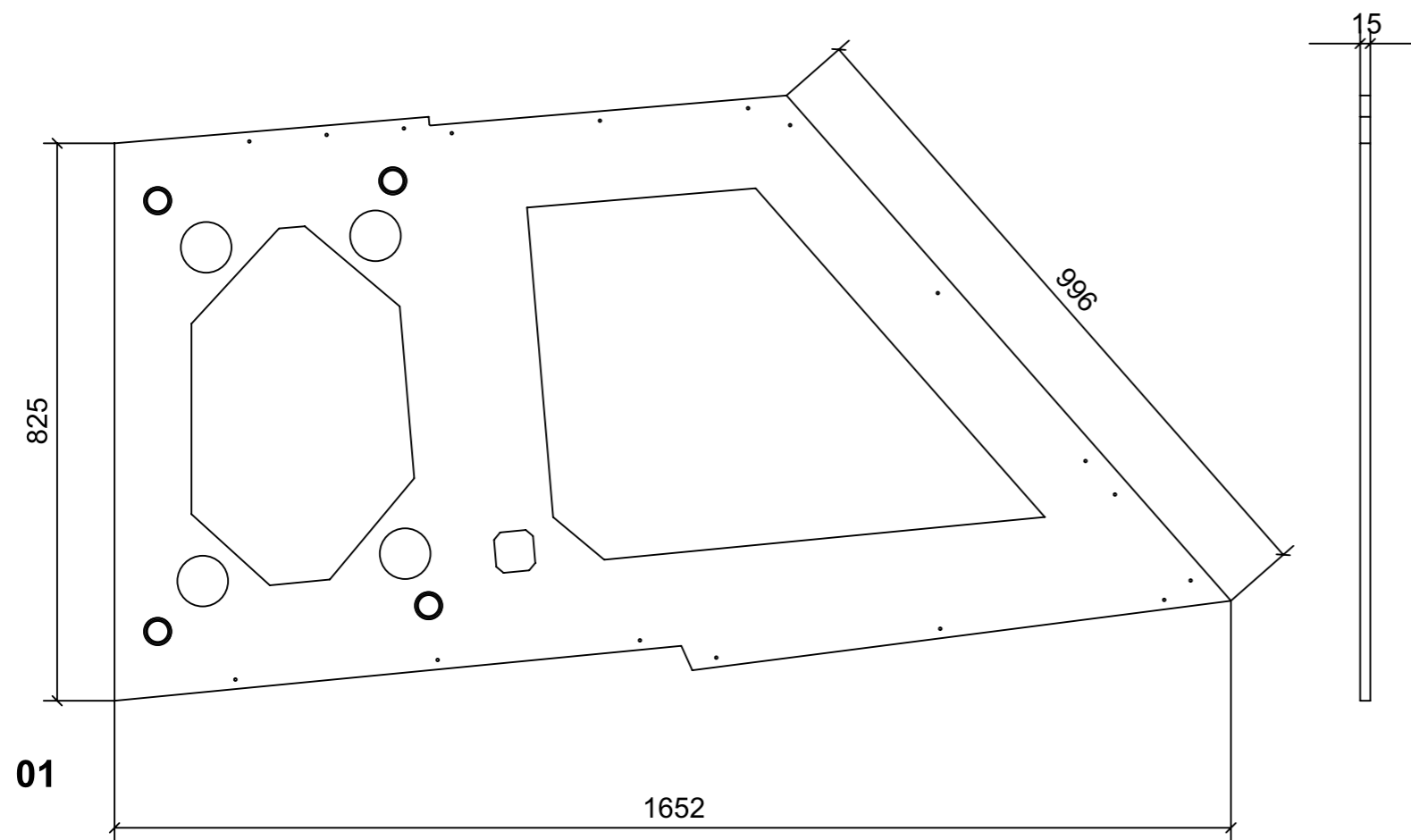

FERRAMENTA	QTY
FITLOCK F_MASCHERPA_6020101102	4

LOCALE	CODICE	DESCRIZIONE COMPONENTE	FINITURA	GR.
CABINA ARMATORE	MD320_AK01	PLENUM MURATA DX POPPA	GREZZO VERNICIATO ANTI ROMBO	PTP

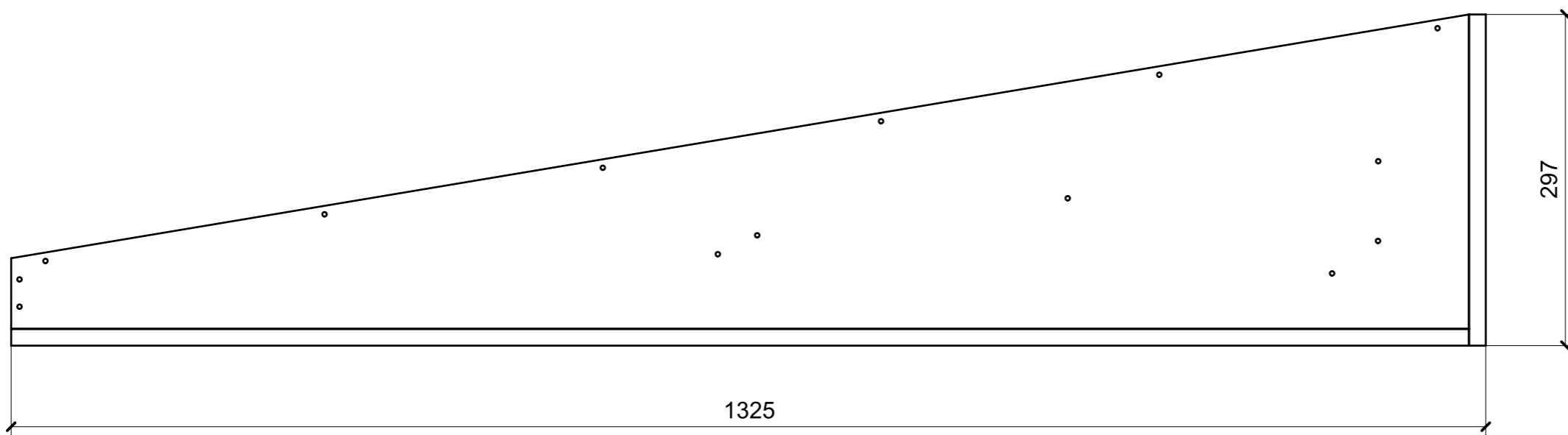
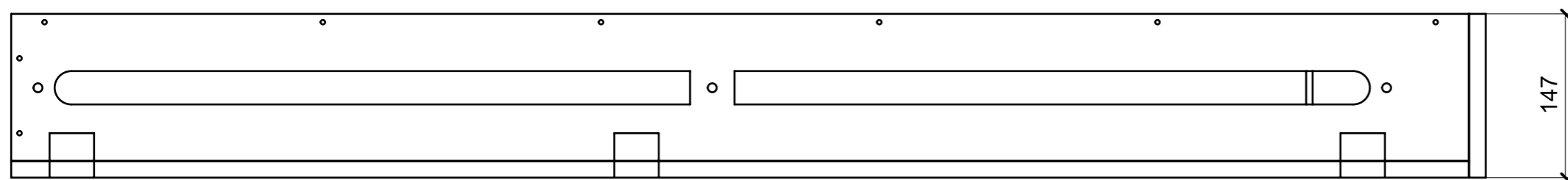
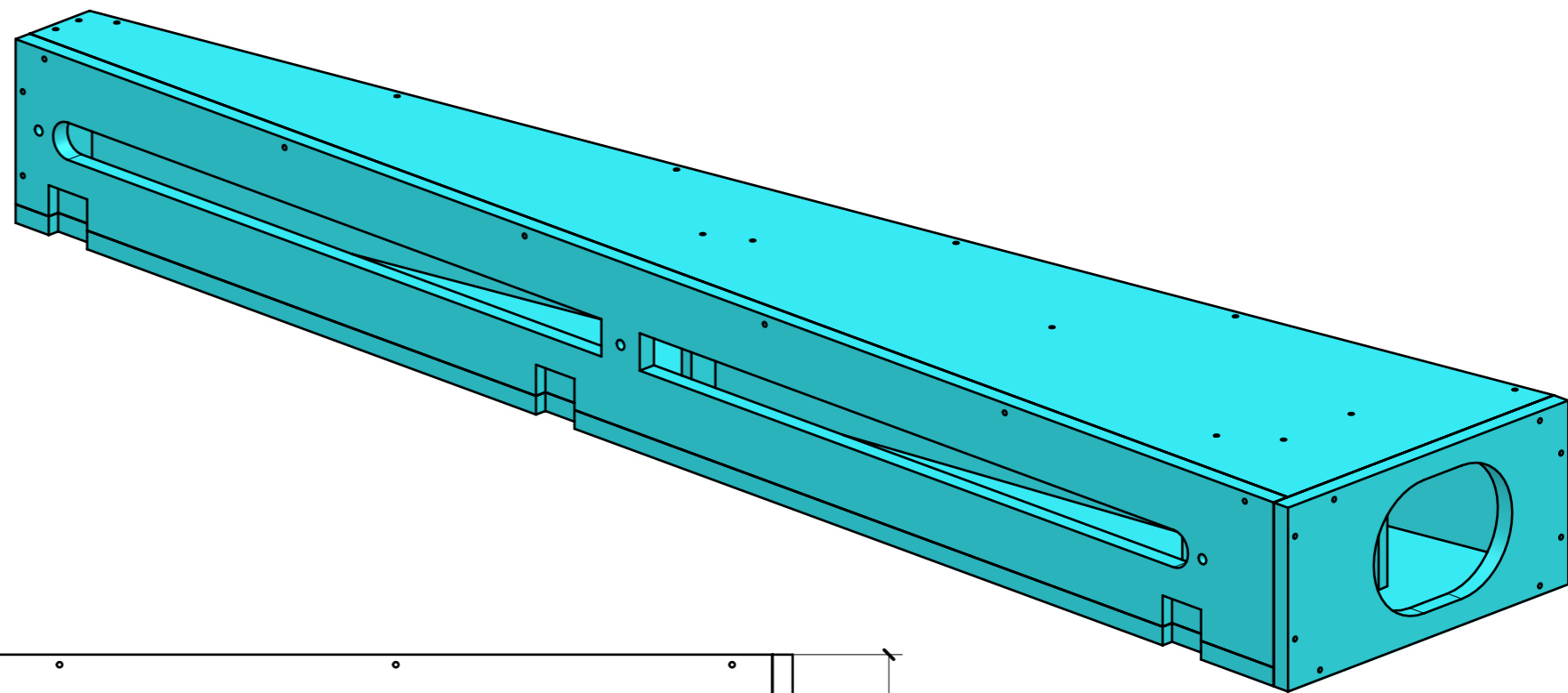

VERNICIATURA LASTRA/LACCATI:

● = FILI RASATI

● = VERNICIARE 1 LATO + FILI RASATI O BORDATI

NESSUN SIMBOLO = VERNICIARE 2 LATI + FILI RASATI O BORDATI

LOCALE	CODICE	DESCRIZIONE COMPONENTE	FINITURA	GR.
CABINA ARMATORE	MD320_AL01	LETTO	LAMINATO SMART 0180-2 JUNGLE/OKUME' GREZZO	4

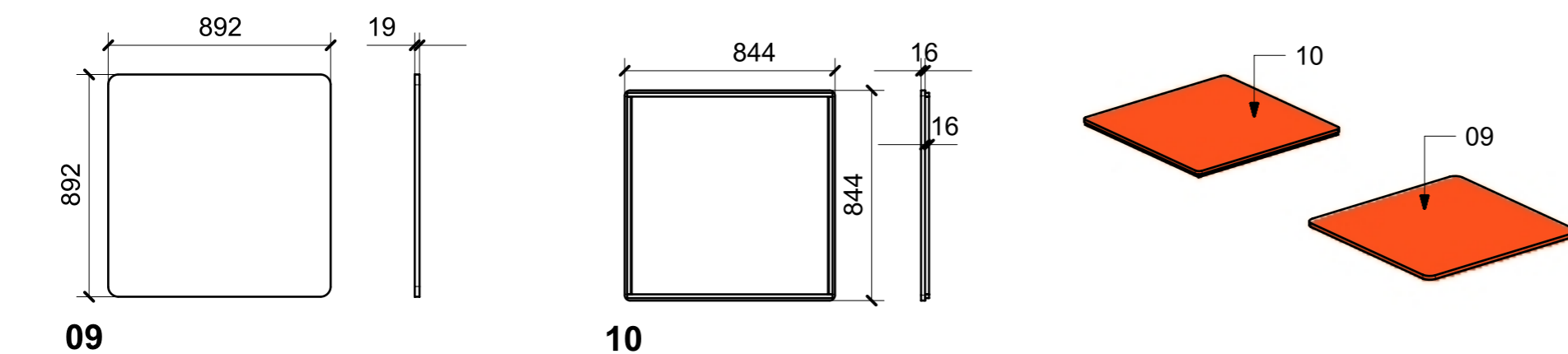
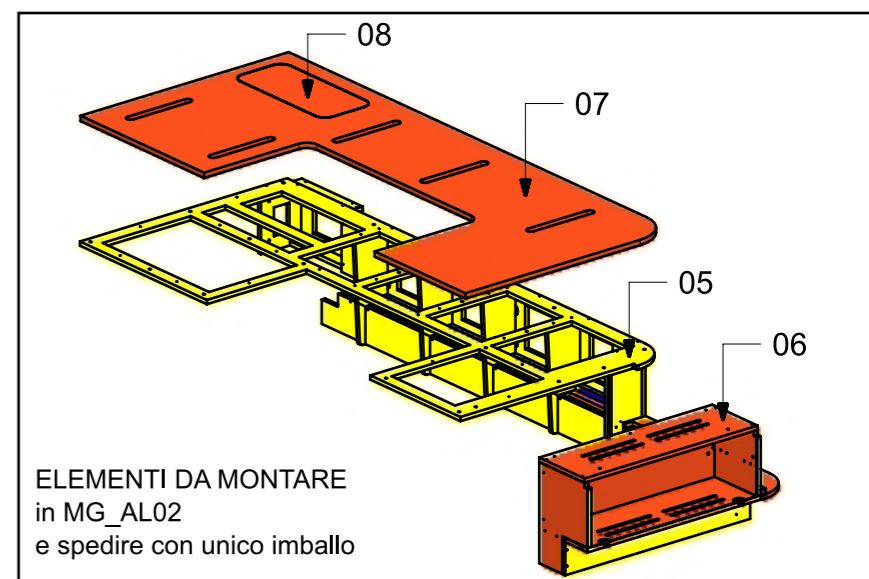
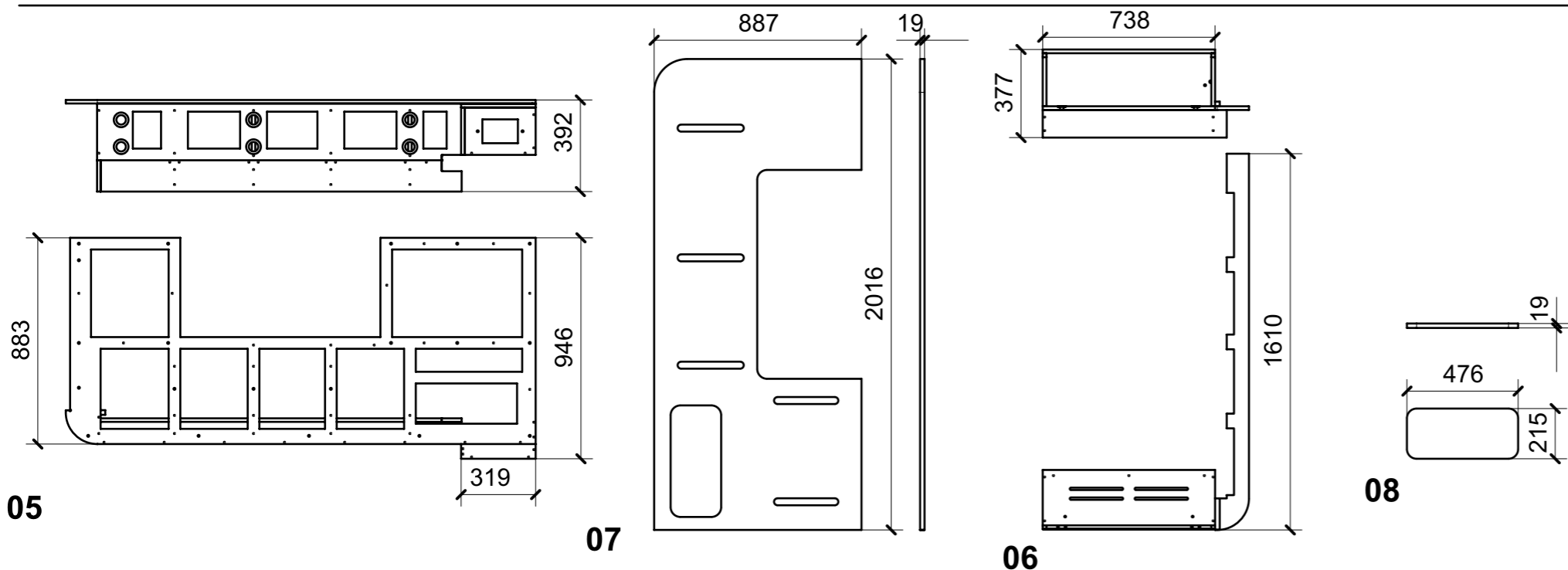
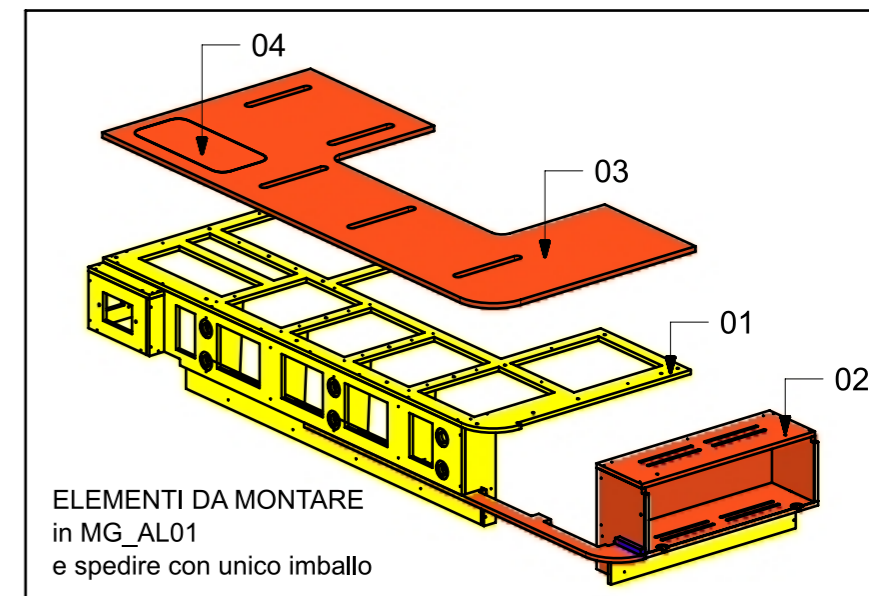
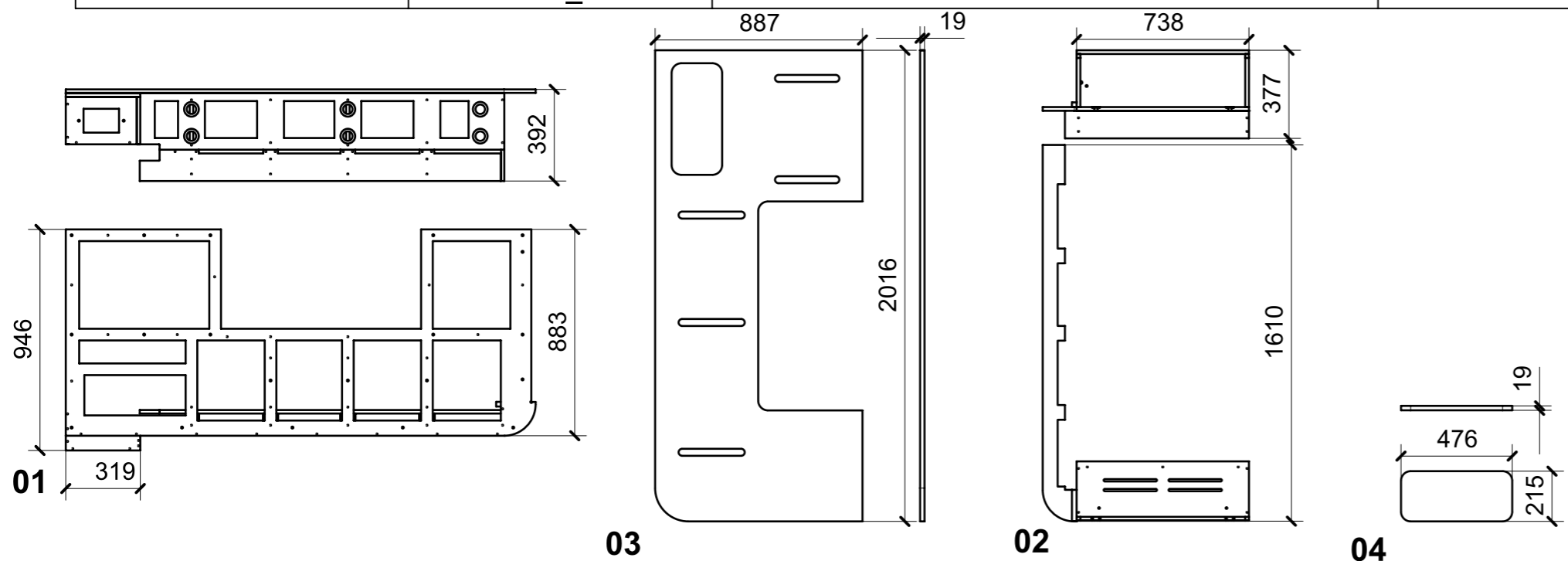

FERRAMENTA	QTY
40130000_STP	4
BUSSOLA 6MA X 10 FORO DIAM.8	10
COVER SCOCCA KIMANA SKIN H0 LIVENZA 40130400_STP	4
FITLOCK F_MASCHERPA_6020101102	12
KIARO COPERTURA SUPPORTO FIANCO 46301120	2
KIARO INSERTO FIANCO POSTERIORE CORDINO 46301130	2
KIARO MECCANISMO 4600600W	2
KIARO PROFILO COPERTURA FIANCO 46205500_STP	2
KIARO SUPPORTO FIANCO CON PERNO 46302040	2
VITE 6MA X 25 TESTA BOMBATA NERA BHCS 10.9 ISO 7380	6

LOCALE	CODICE	DESCRIZIONE COMPONENTE	FINITURA	GR.
CABINA ARMATORE	MD320_AM01	GRADINI GREZZI ARMATORE	OKOUME' GREZZO\ SPRUZZATO NERO	2

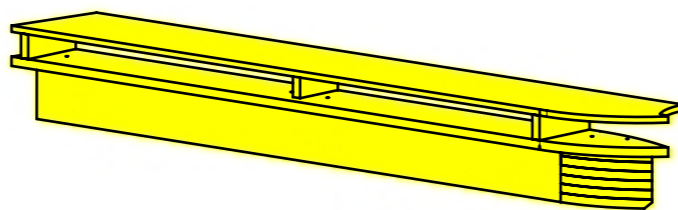

01

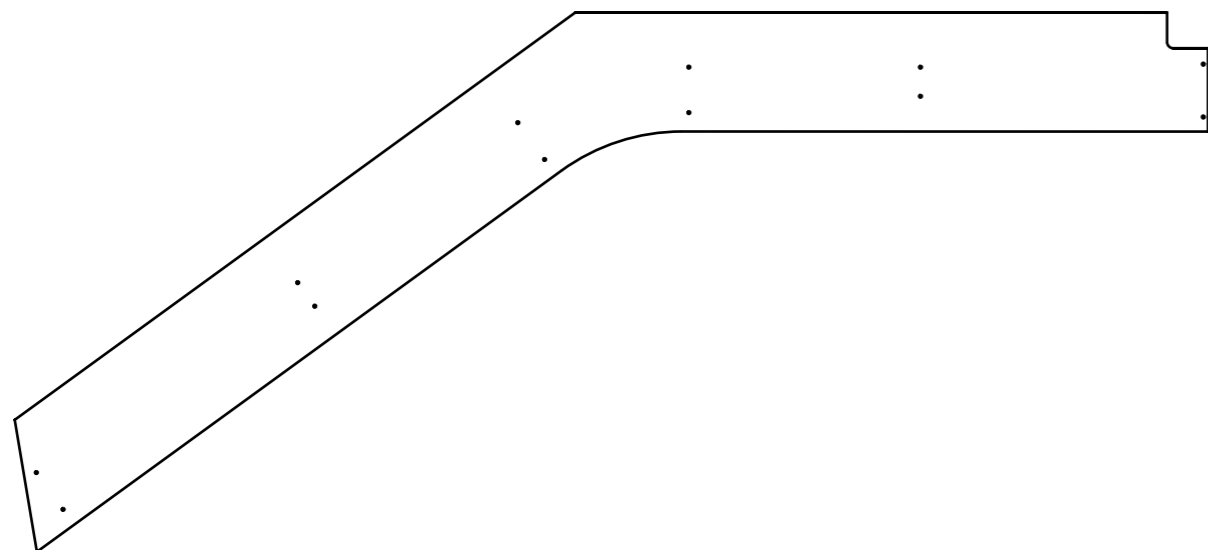
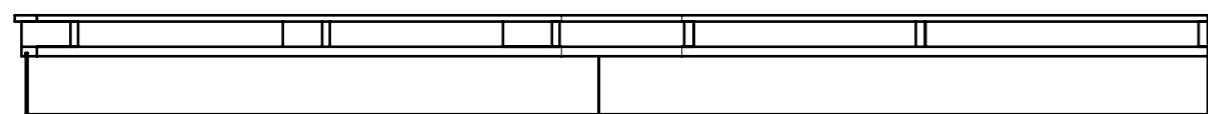

02

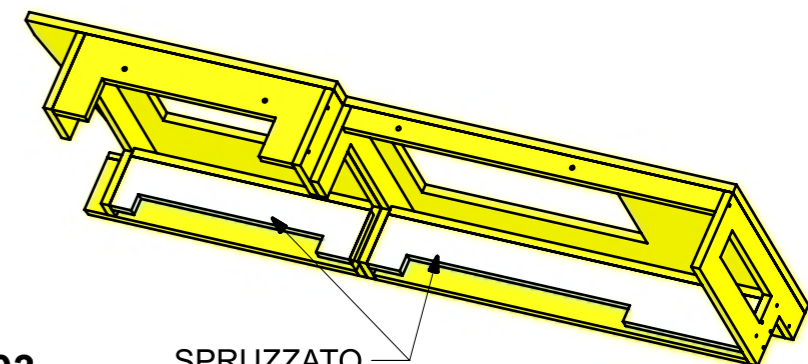
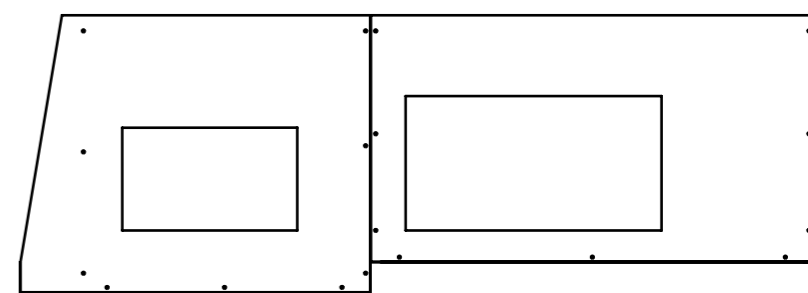
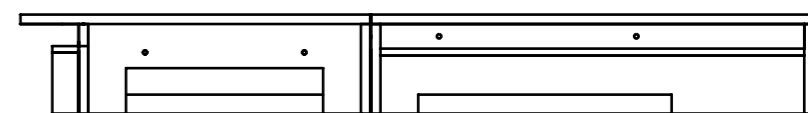
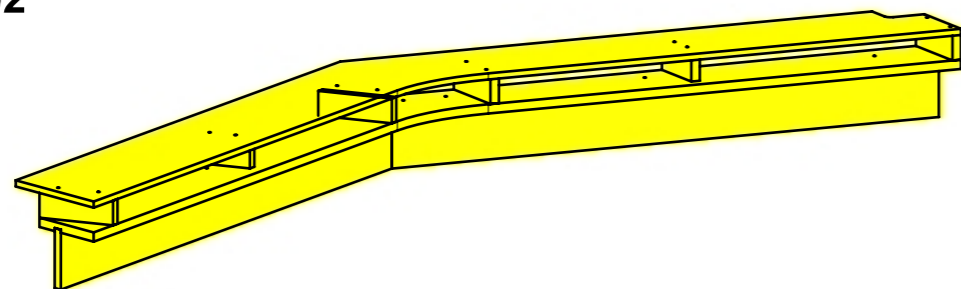

03

SPRUZZATO NERO

VISTA DA SOTTO

LOCALE	CODICE	DESCRIZIONE COMPONENTE	FINITURA	GR.
CABINA ARMATORE	MD320_AN01	PLENUM MURATA SX POPPA	GREZZO VERNICIATO ANTI ROMBO	PTP

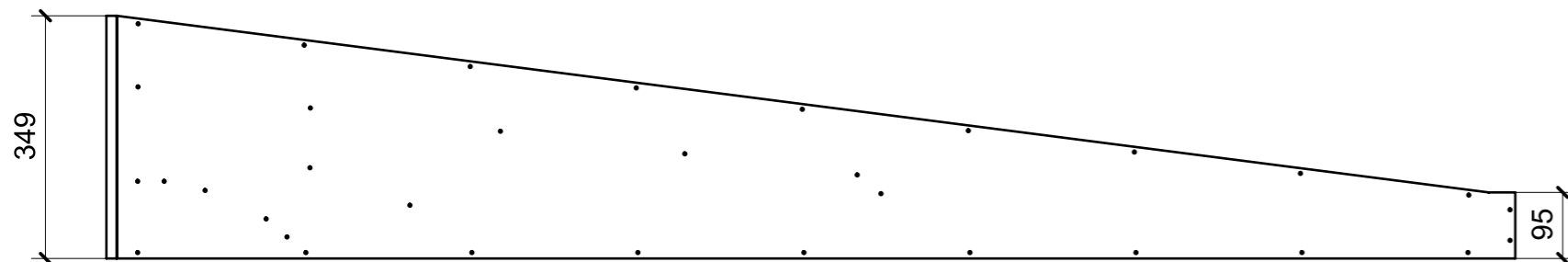
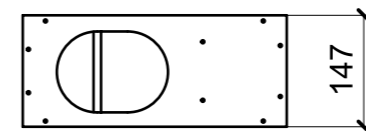
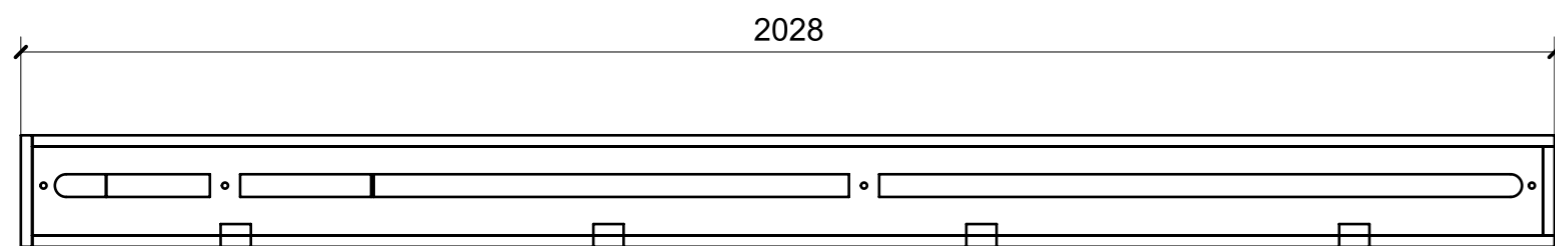
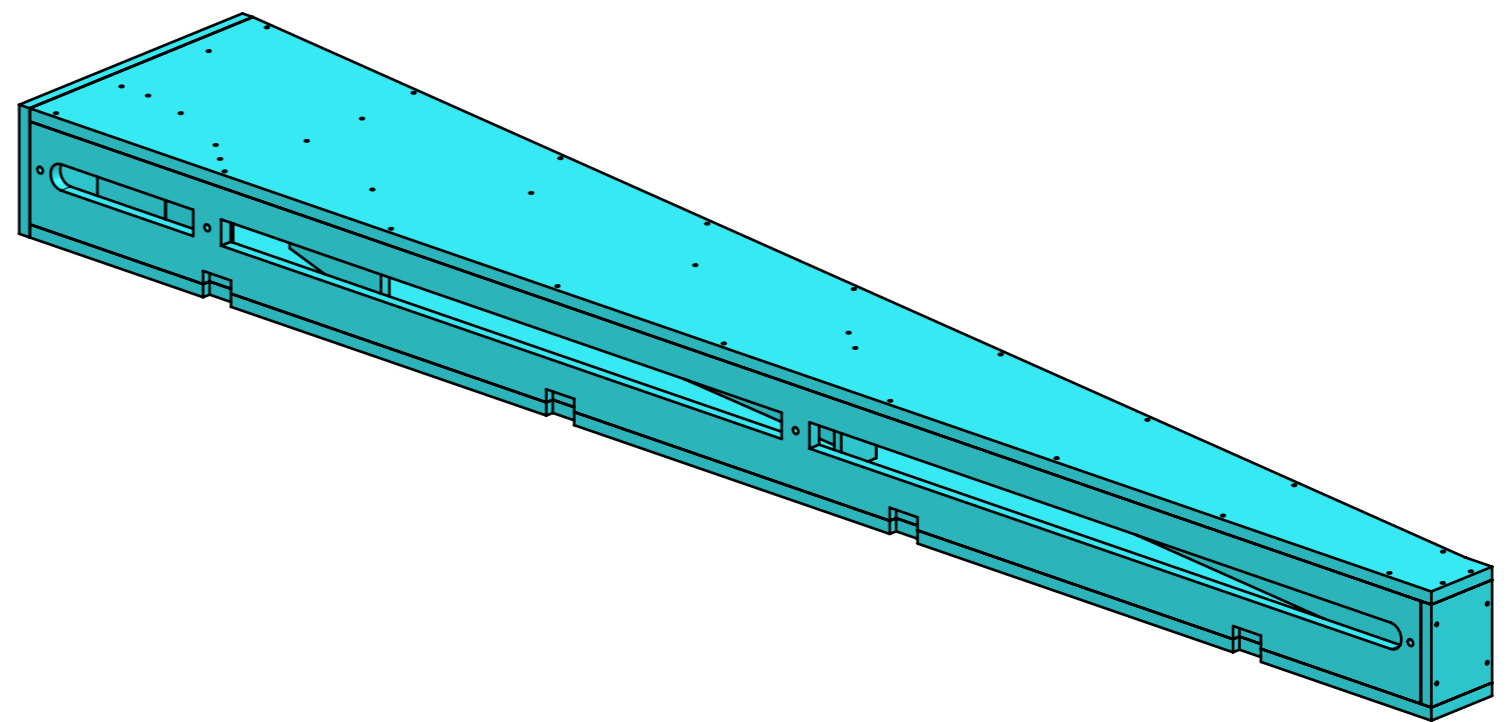

VERNICIATURA LASTRA/LACCATI:

● = FILI RASATI

● = VERNICIARE 1 LATO + FILI RASATI O BORDATI

NESSUN SIMBOLO = VERNICIARE 2 LATI + FILI RASATI O BORDATI

LOCALE	CODICE	DESCRIZIONE COMPONENTE	FINITURA	GR.
CABINA ARMATORE	MD320_AO01	CIELINO PARTE CENTRALE	CARTA MELAMINICA NERA	3

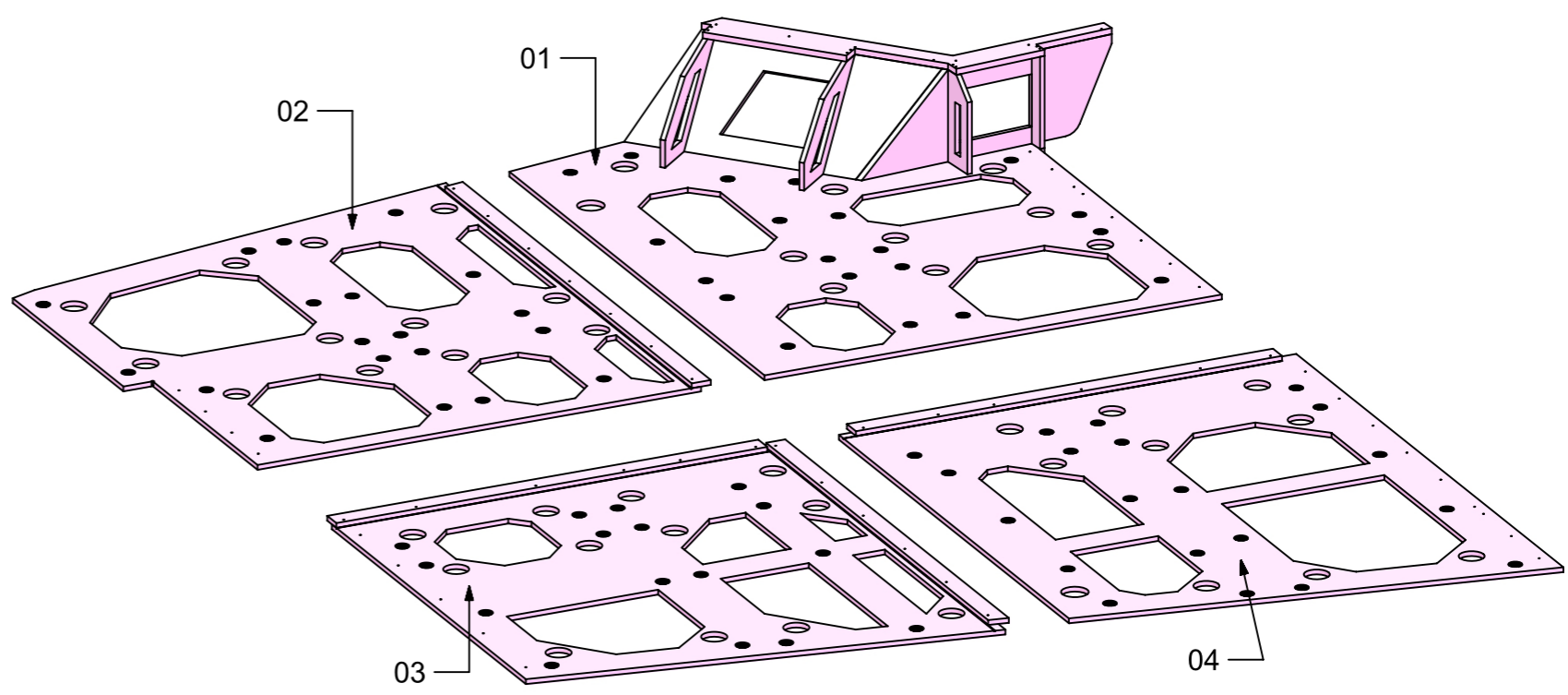
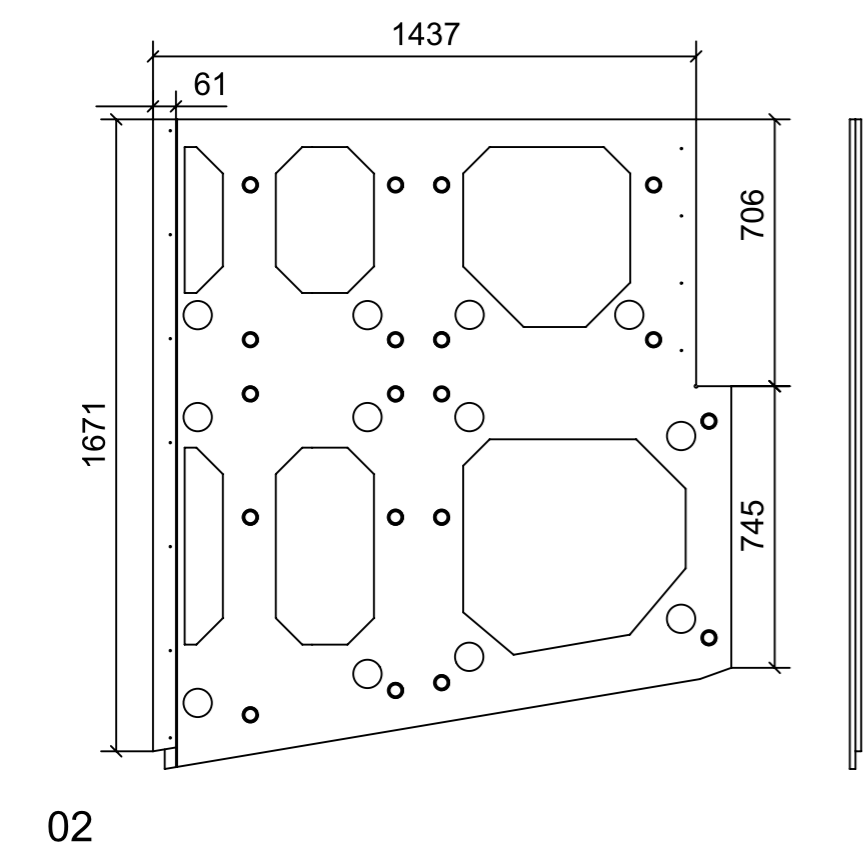
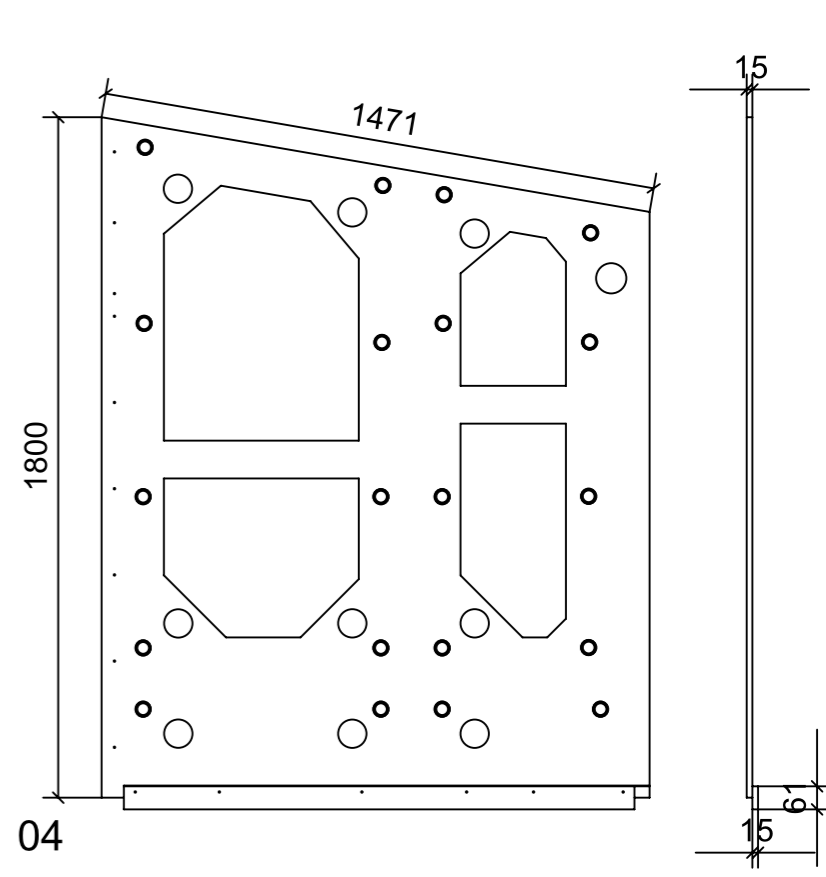
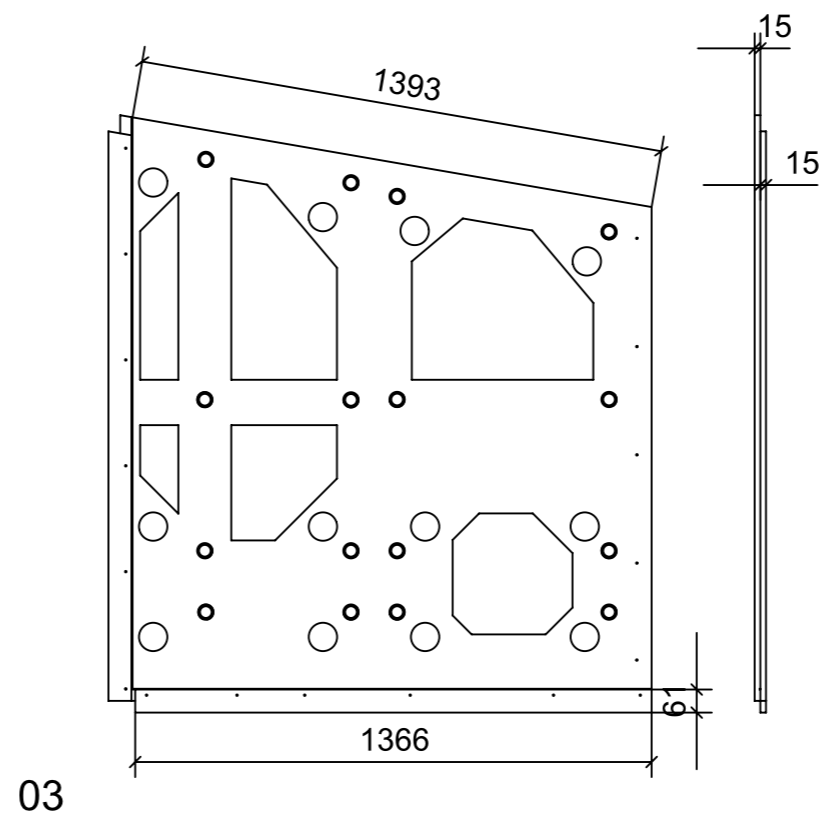
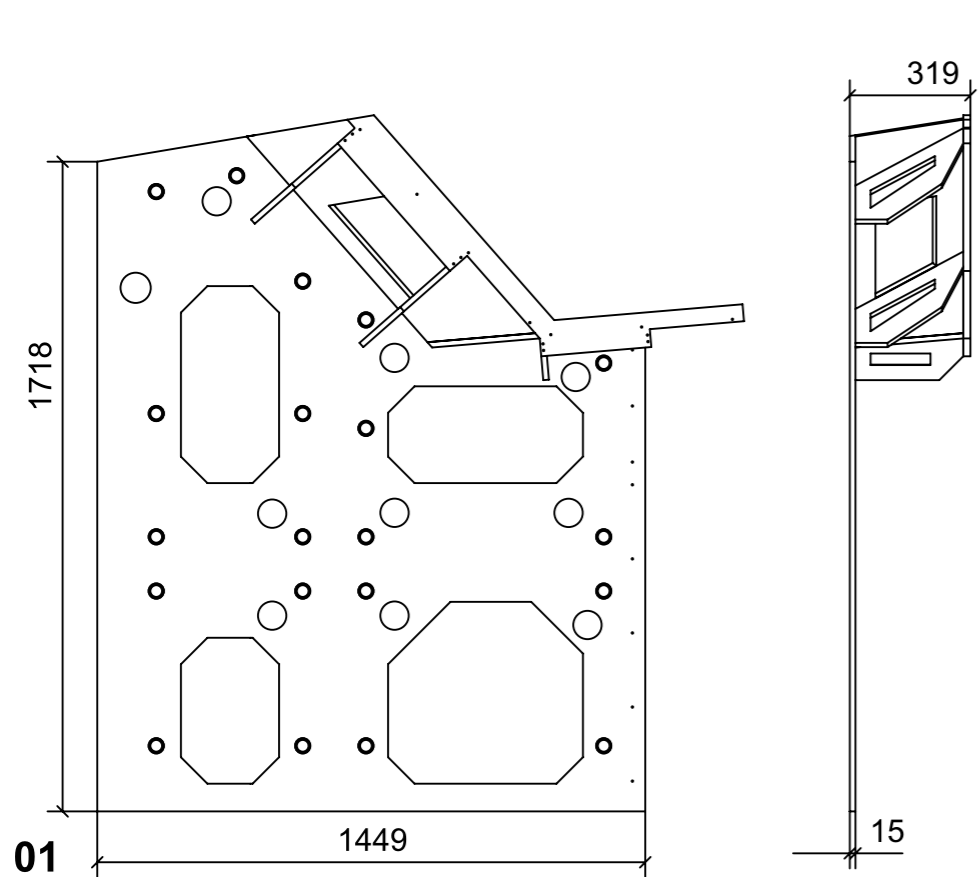

FERRAMENTA	QTY
FITLOCK F_MASCHERPA_6020101102	75

LOCALE	CODICE	DESCRIZIONE COMPONENTE	FINITURA	GR.
CABINA ARMATORE	MD320_AP01	CIELINO MURATA SX POPPA	CARTA MELAMINICA NERA	2

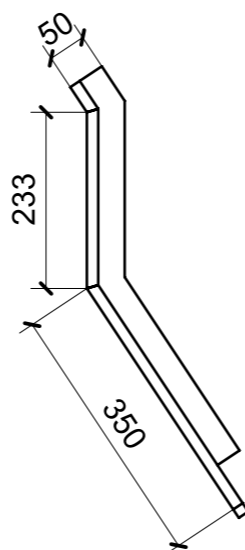
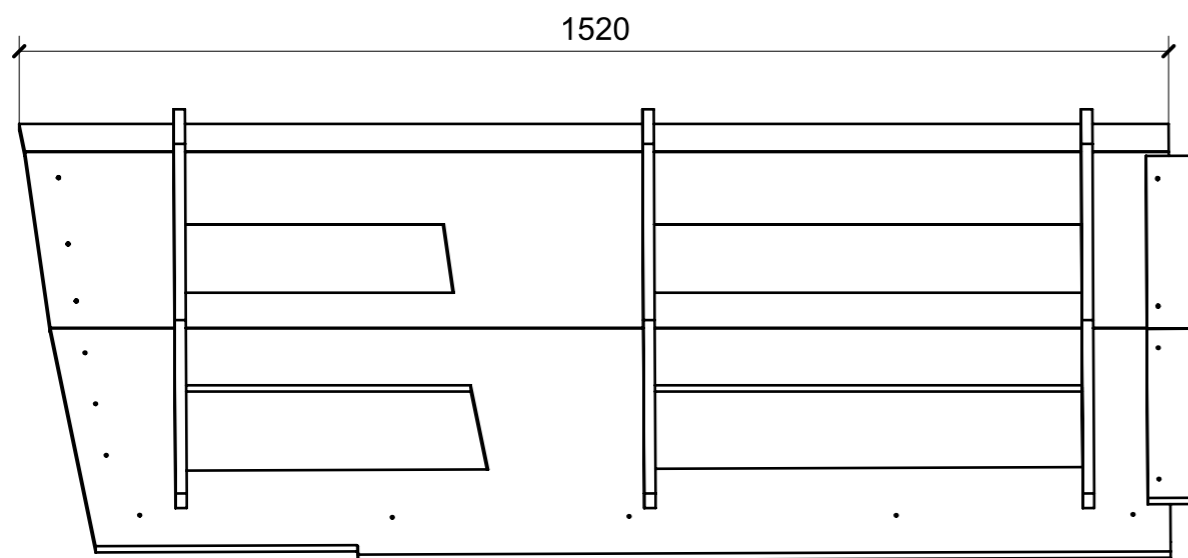
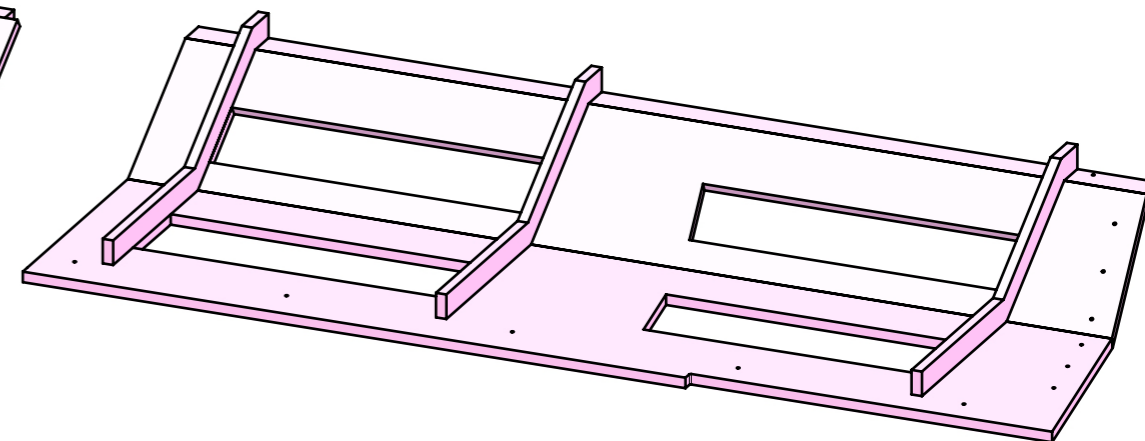
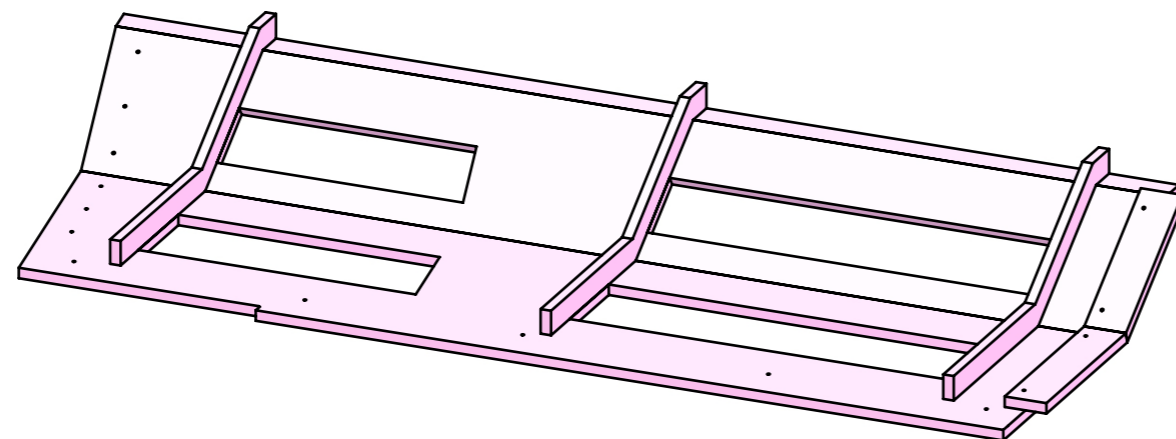

01

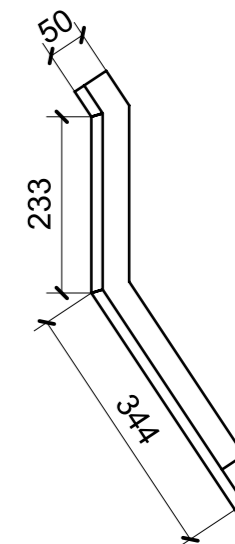
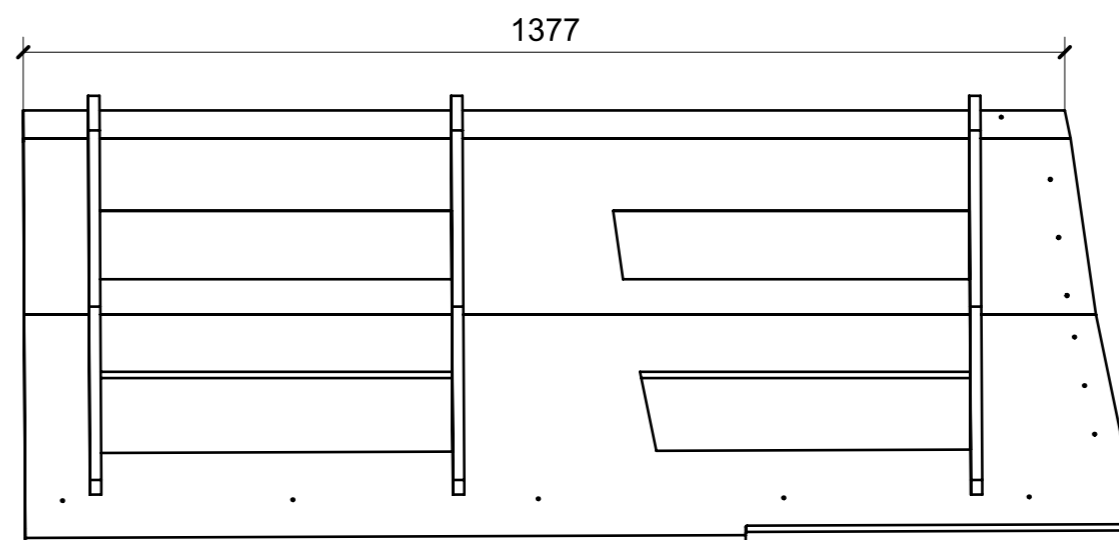

02

LOCALE	CODICE	DESCRIZIONE COMPONENTE	FINITURA	GR.
CABINA ARMATORE	MD320_AQ01	CIELINO MURATA DX POPPA	CARTA MELAMINICA NERA	2

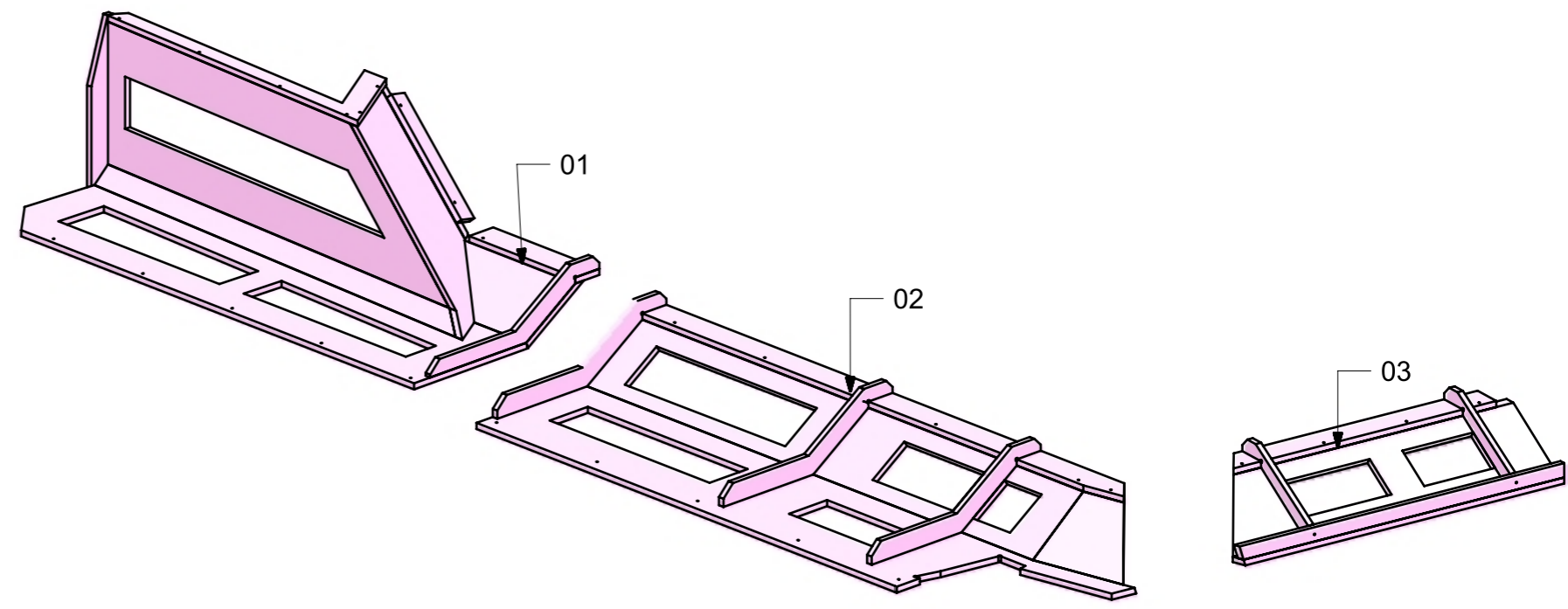
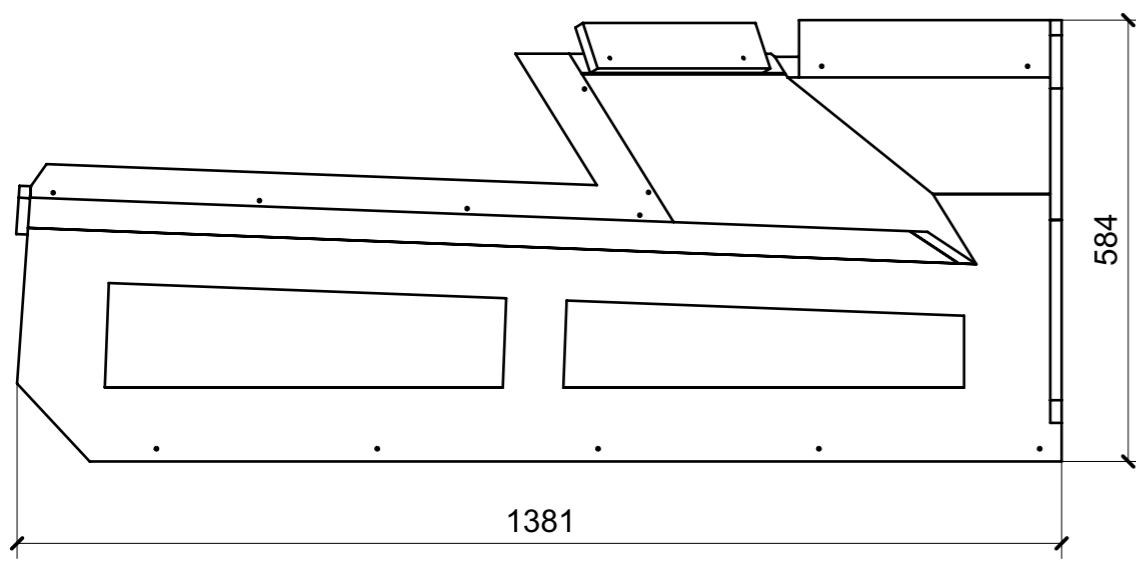
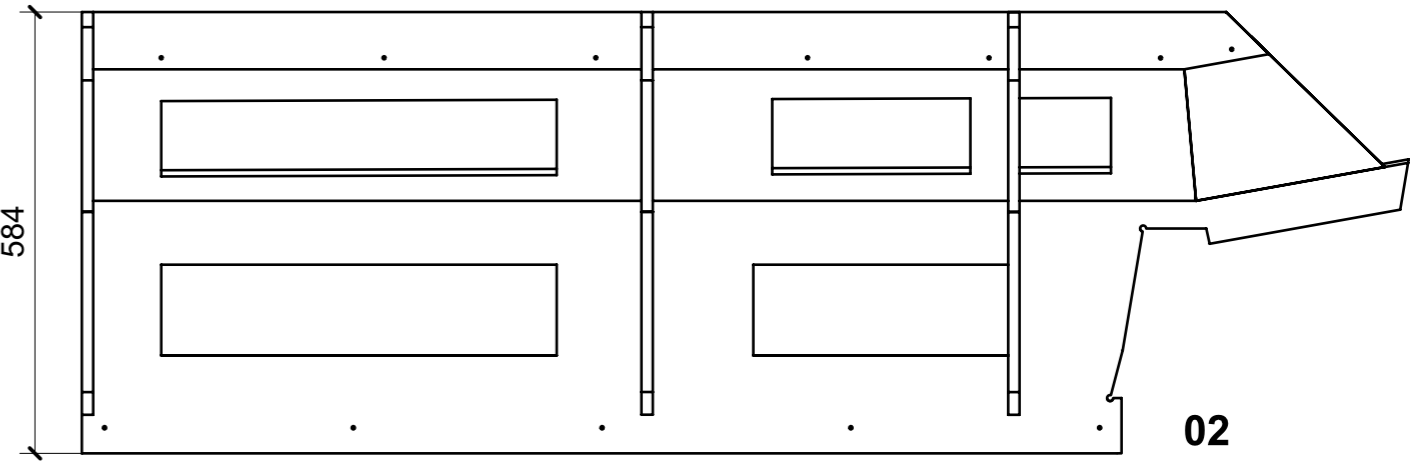
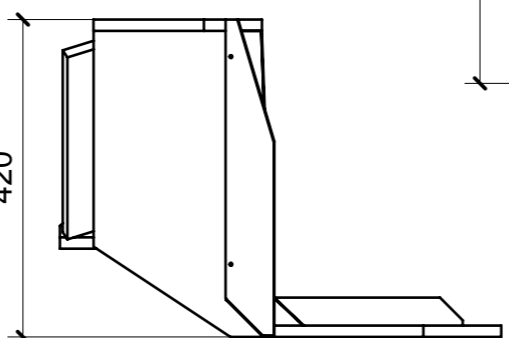
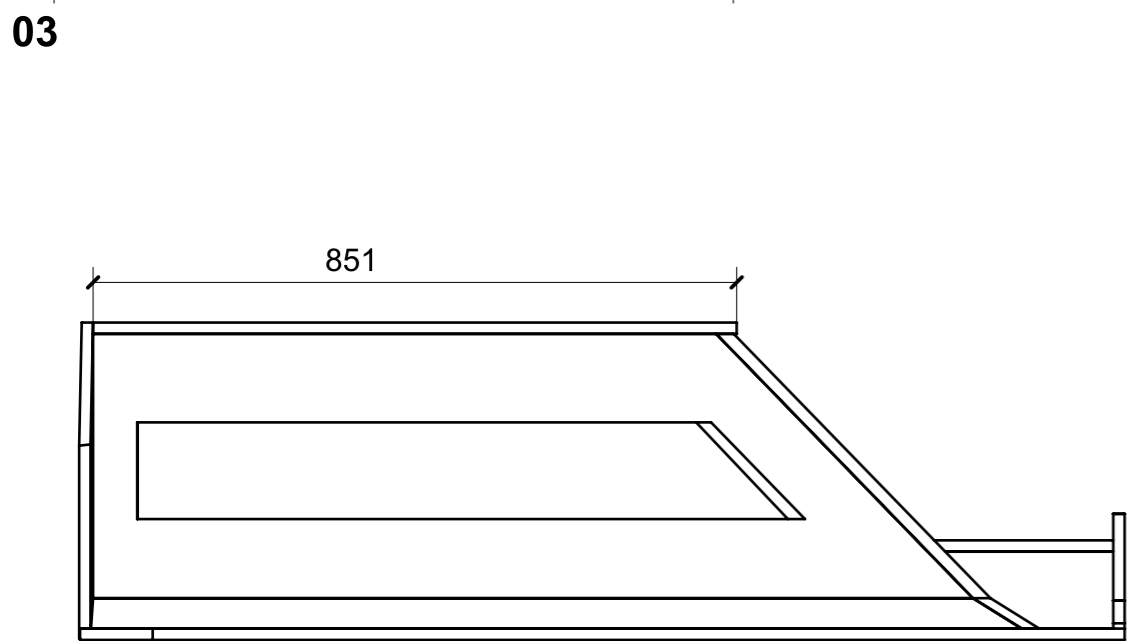
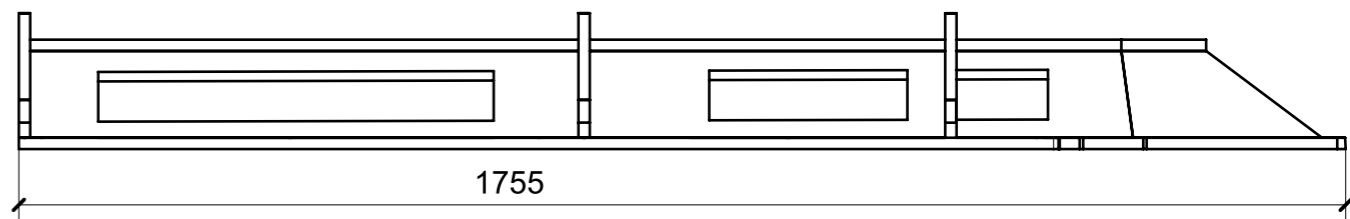
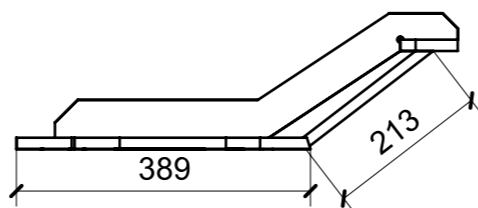
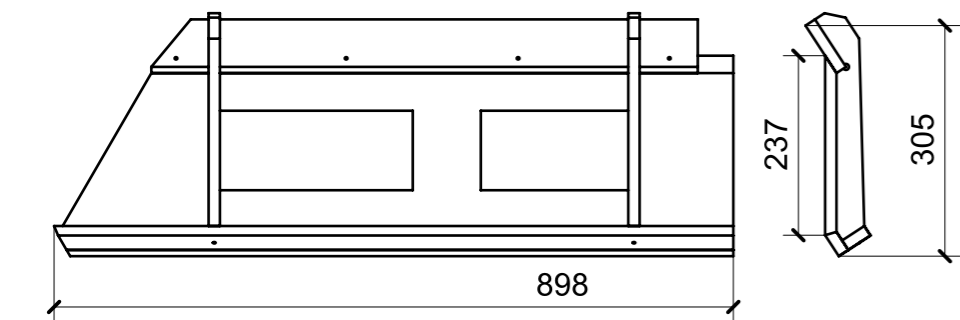

01

02

03

LOCALE	CODICE	DESCRIZIONE COMPONENTE	FINITURA	GR.
CABINA ARMATORE	MD320_AR01	ARMADIO DRESSING PRUA	LAMINATO SMART 0180-2 JUNGLE	4

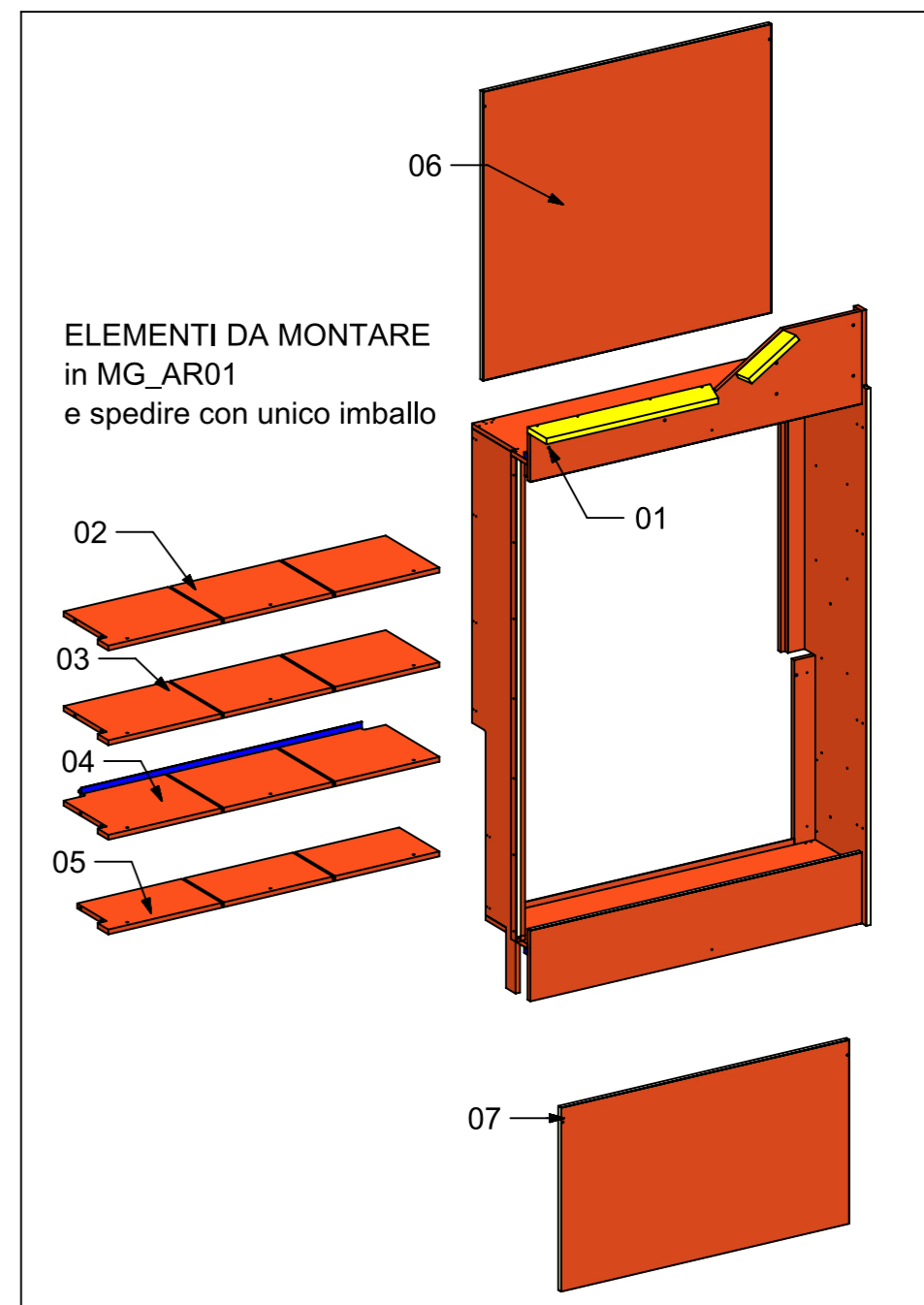
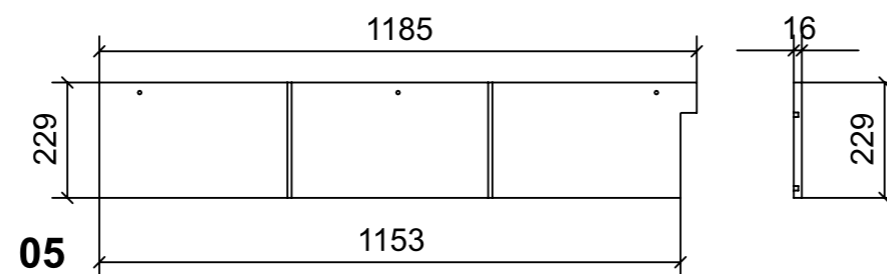
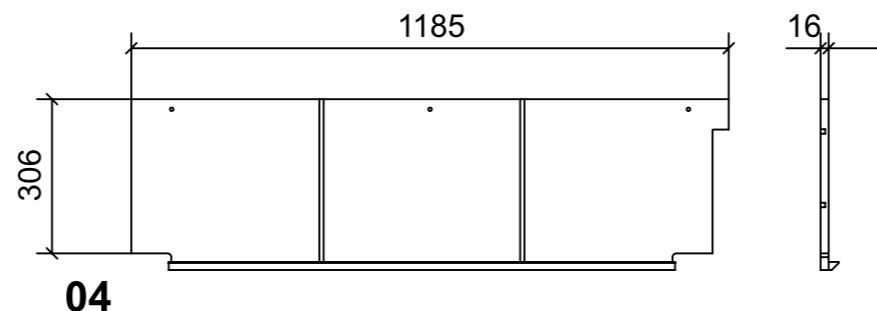
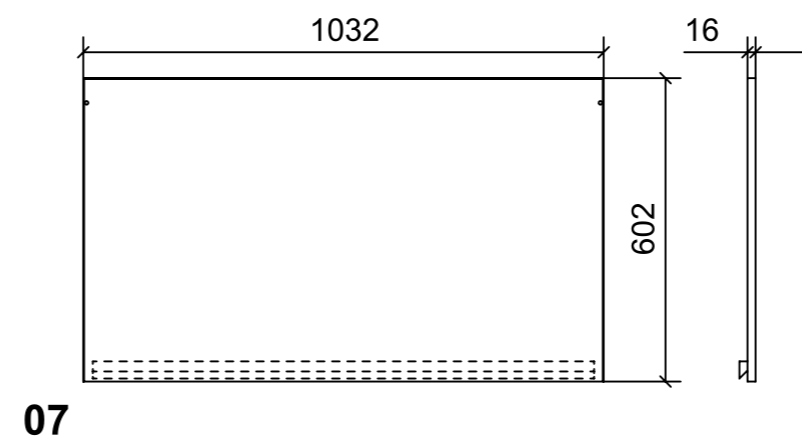
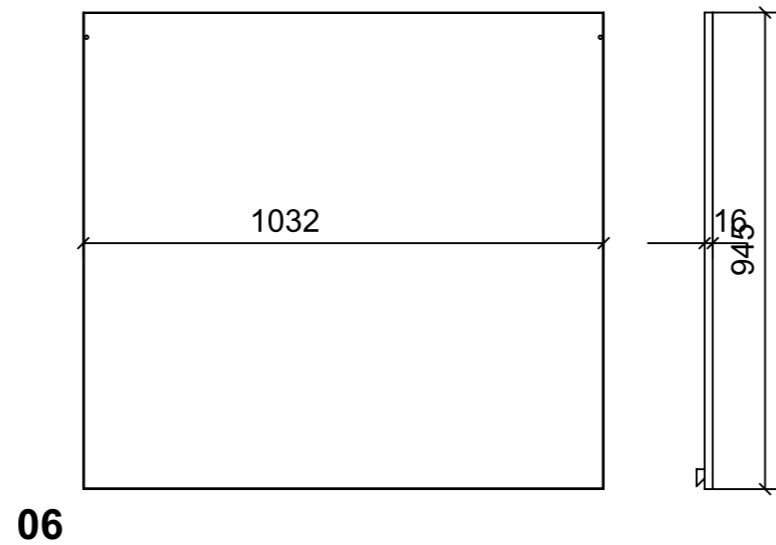
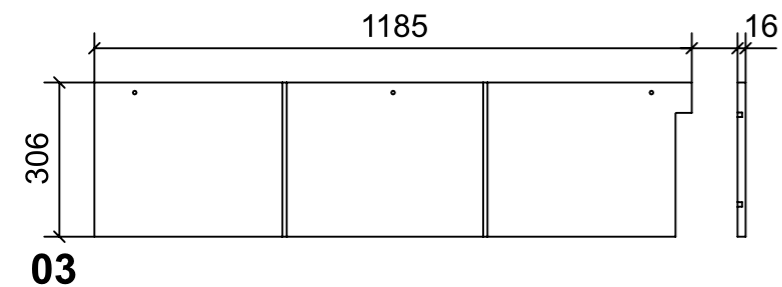
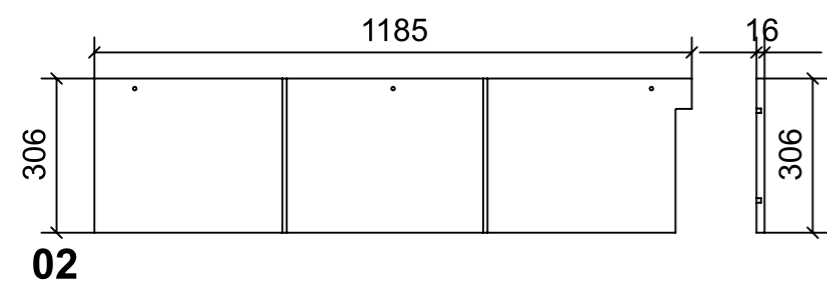
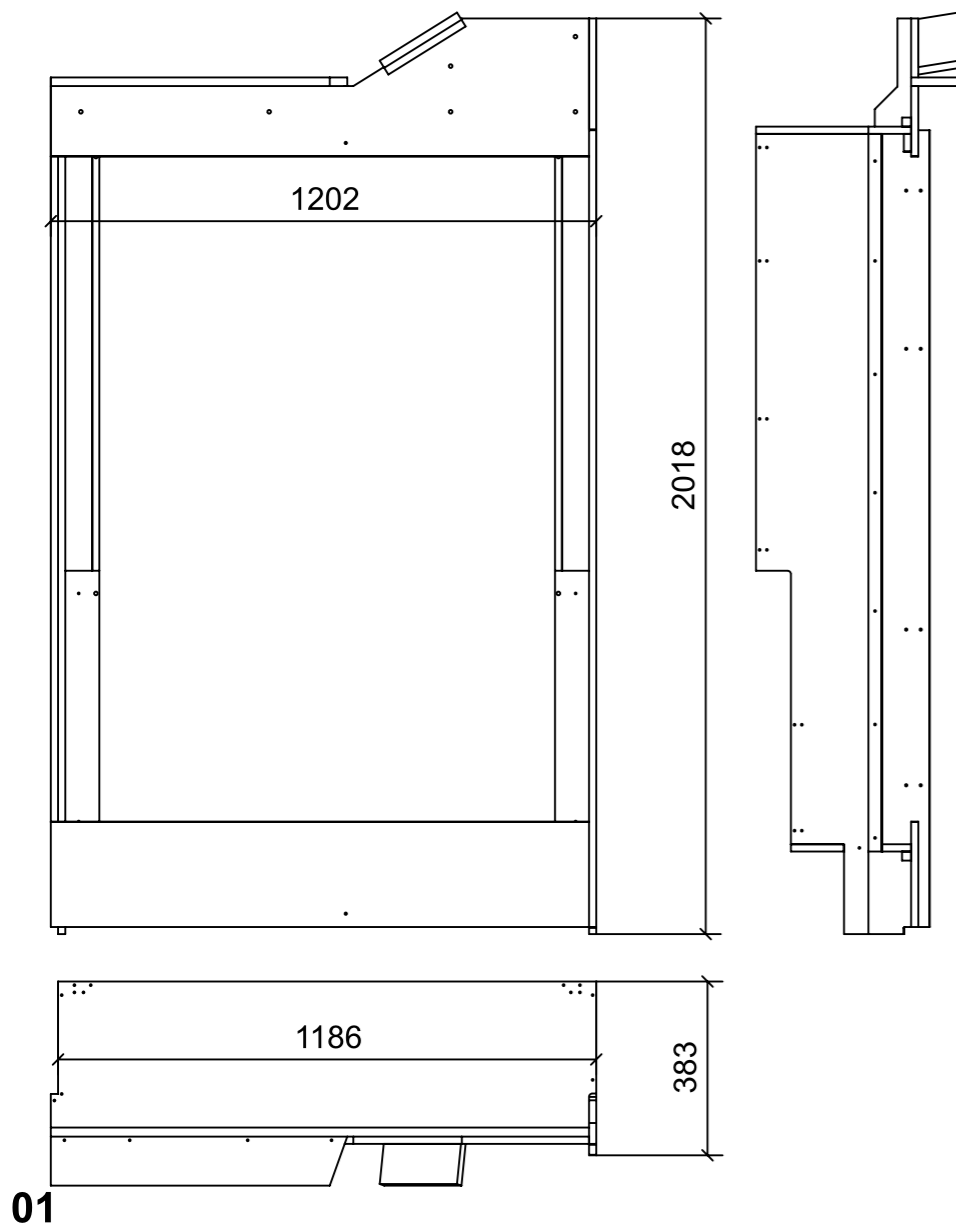

FERRAMENTA	QTY
BUSSOLA 6MA X 10 FORO DIAM.8	9
RISCONTRO IN FERRO PER CALAMITA TONDO	2
VITE 6MA X 25 TESTA BOMBATA NERA BHCS 10.9 ISO 7380	4
VITE 4MAX8 ANKOR BORGHI	8
BUSSOLA 5MA ANKOR BORGHI	10
CERNIERA 94°_PIANA-NERA_HAFELE_342.46.604-BLUM_71B9550.STP	4
BASE_3-NERA_HAFELE_342.22.067-BLUM_175H3130.STP	4
PERNO LISCIO PER SPALLA_FBC BORGHI_1033PXX050531	16
GIUNTO REGGIRIPIANO CON BORDO ANTISGANCIO_FBC BORGHI_1033XXB060902	16

LOCALE	CODICE	DESCRIZIONE COMPONENTE	FINITURA	GR.
CABINA ARMATORE	MD320_AS01	GRADINI DISCESA PRUA	OKOUME' GREZZO	PTP

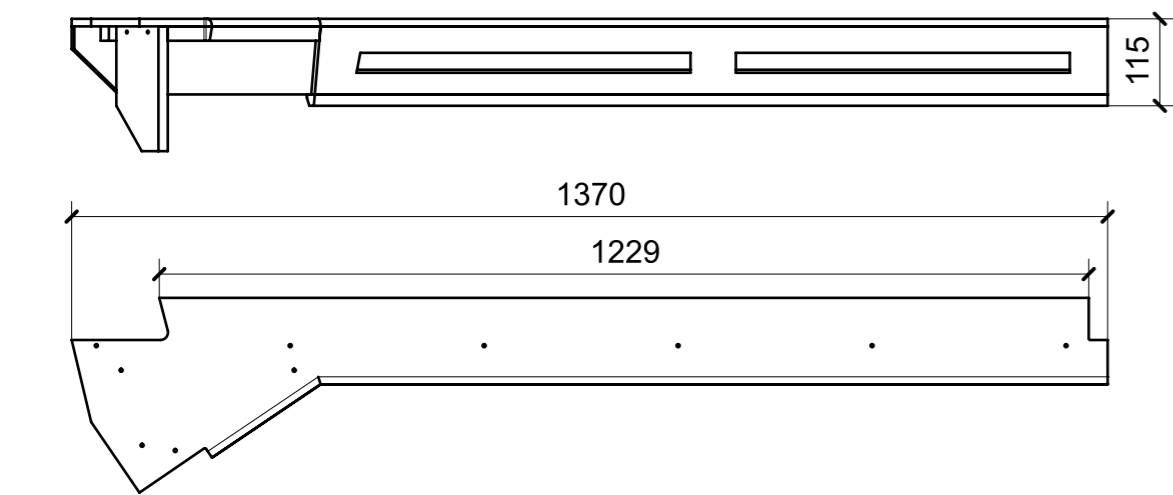
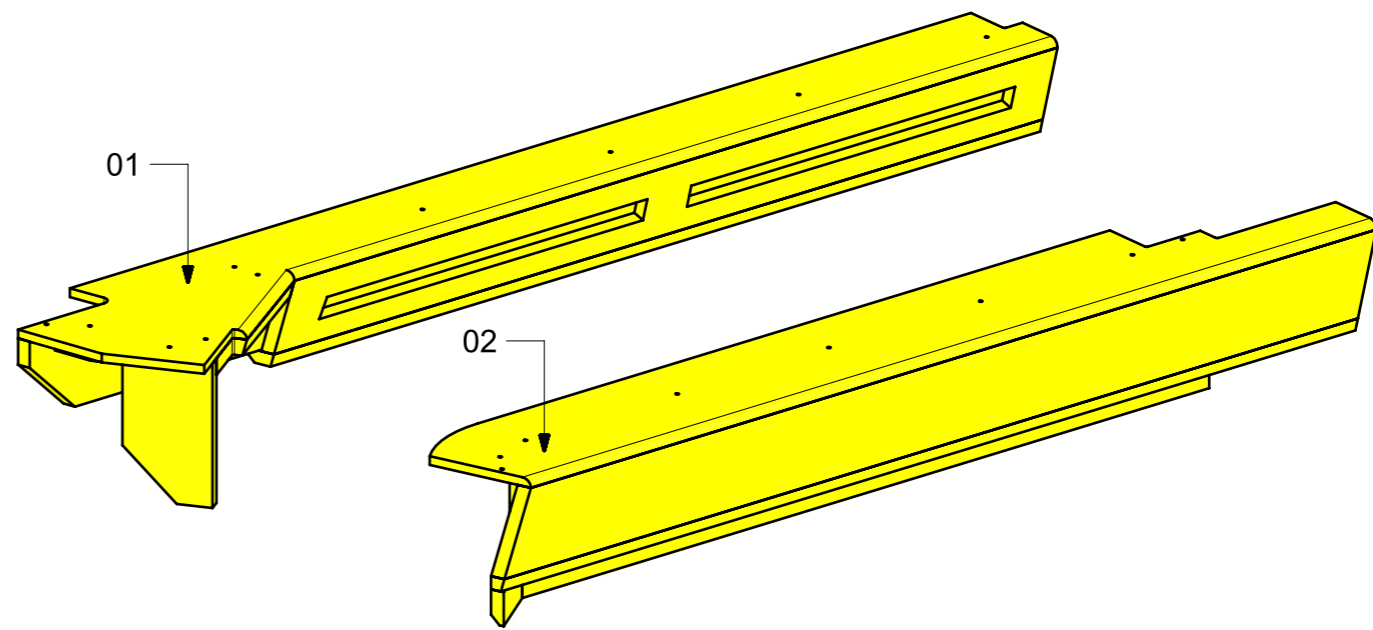

01

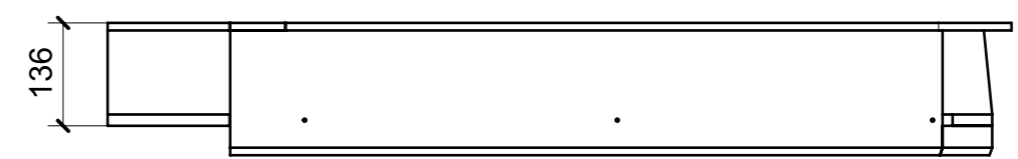
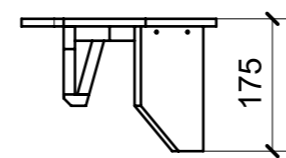

02

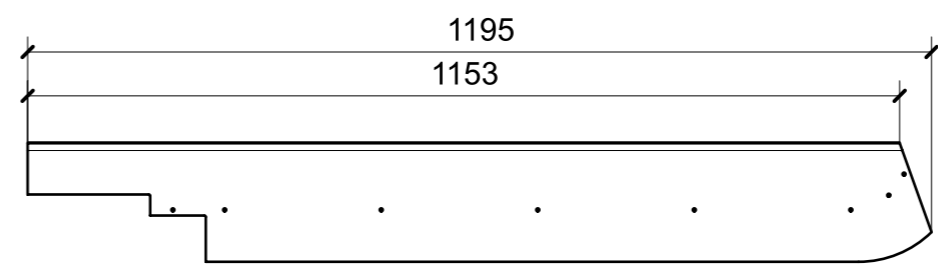

VERNICIATURA LASTRA/LACCATI:

● = FILI RASATI

● = VERNICIARE 1 LATO + FILI RASATI O BORDATI

NESSUN SIMBOLO = VERNICIARE 2 LATI + FILI RASATI O BORDATI

LOCALE	CODICE	DESCRIZIONE COMPONENTE	FINITURA	GR.
CABINA ARMATORE	MD320_AT01	ARMADIO PRUA	LAMINATO SMART 0180-2 JUNGLE	3

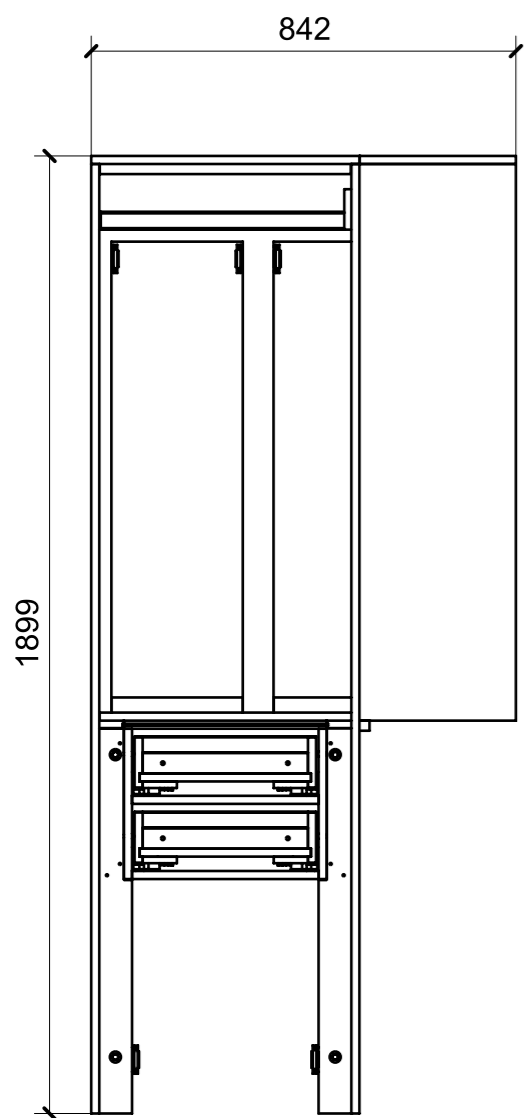

01

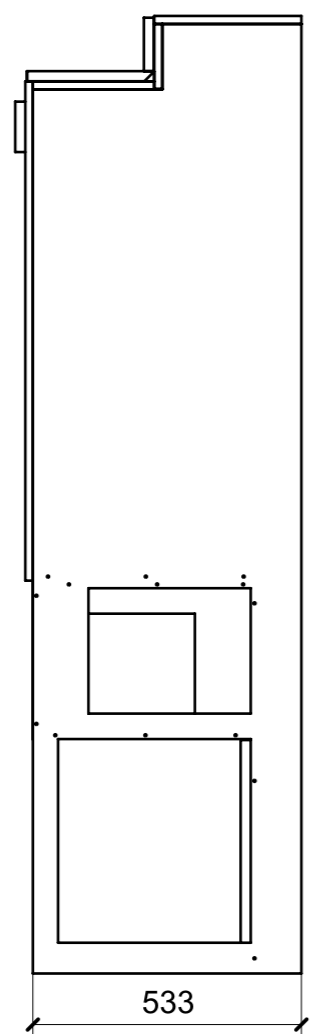

01

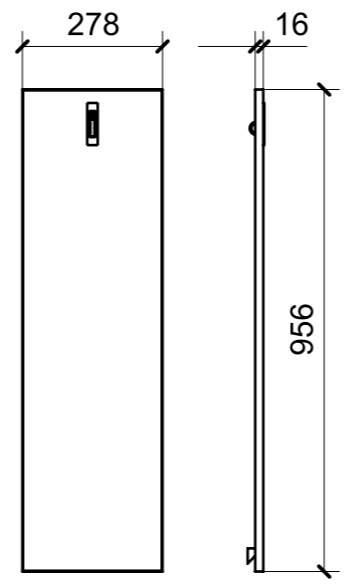

07

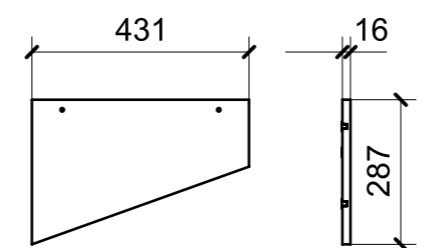

02

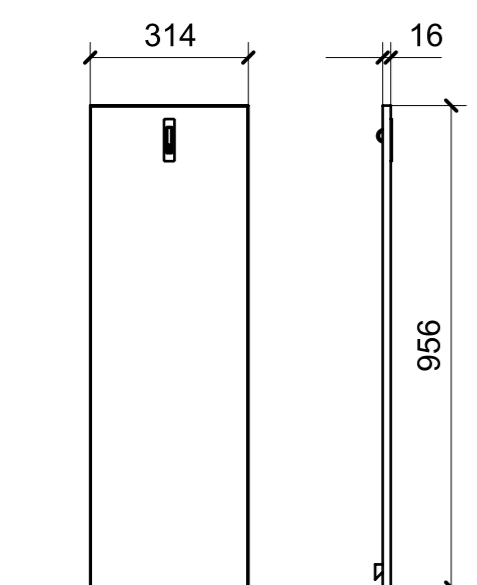

05

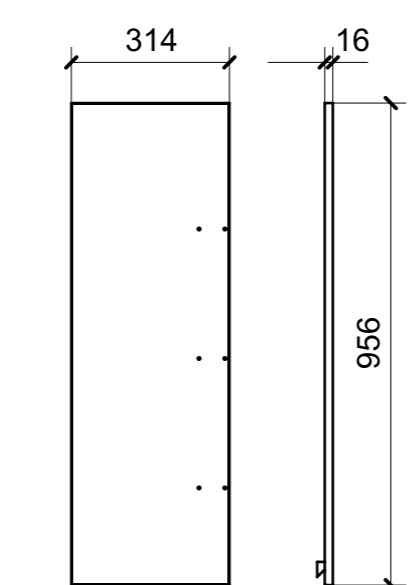

06

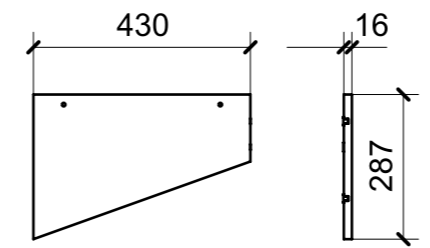

03

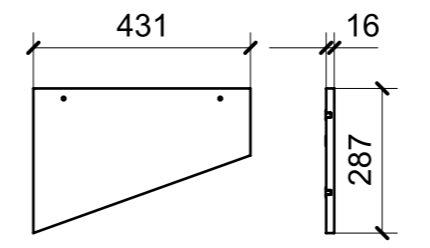

04

ELEMENTI DA MONTARE  
in MG\_AT01  
e spedire con unico imballo

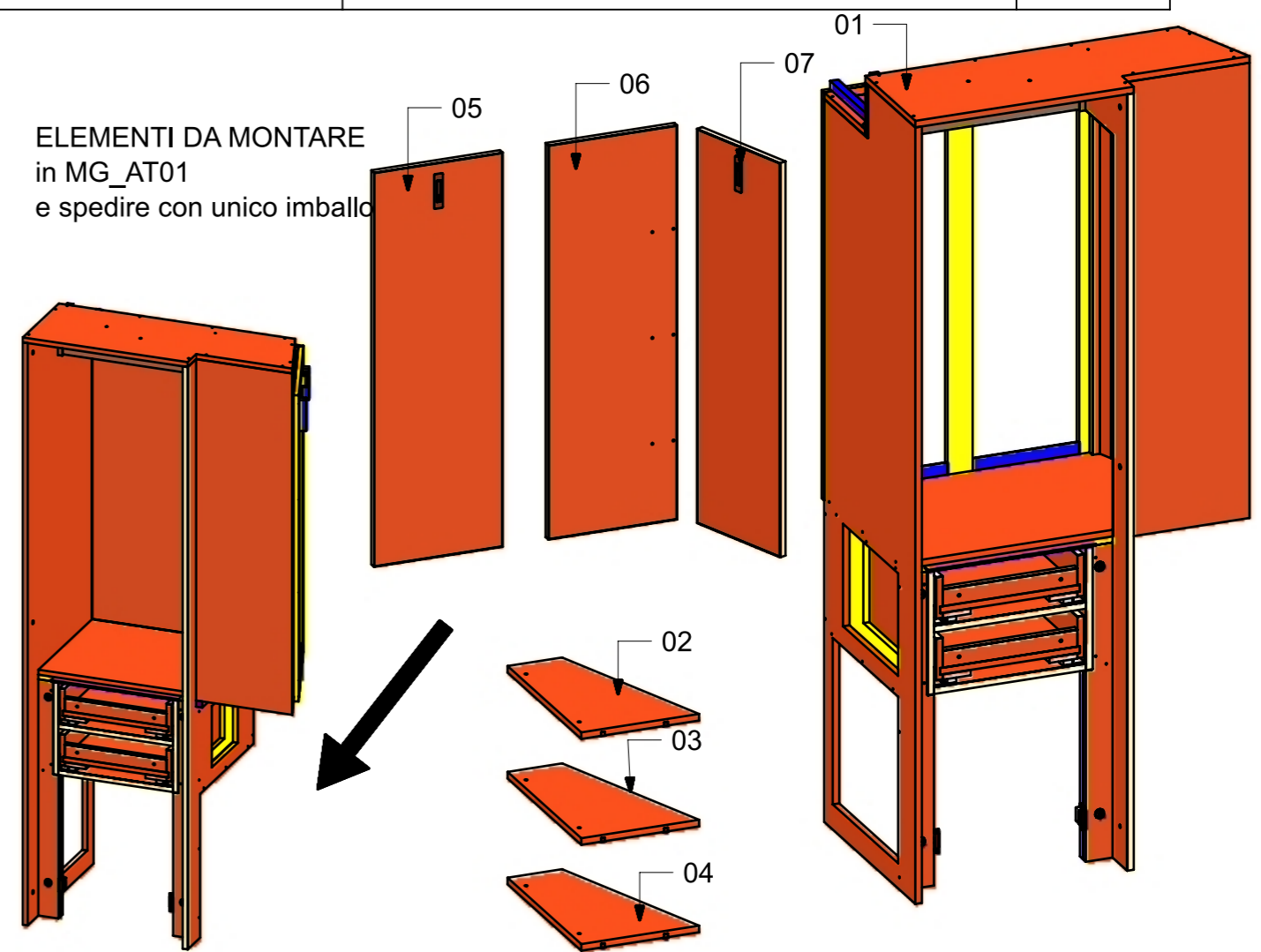

FERRAMENTA	QTY
KIT BARRA APPENDIABITI - CP SUPPORTI+ BARRA	1
FM INCASSO_ITALVIPLA_973_FMPC_F1A	4
GIUNTO REGGIRIPIANO CON BORDO ANTISGANCIO_FBC BORGHI_1033XXB060902	12
KIT BARRA APPENDIABITI - BARRA_AT01_494_MM_HAFELE_801_83_003	1
KIT LED PER ARMADIO MD321 AT01 MM 498	1
CHIUSURA A SPINTA_TECHNOPARTNER_SOU C3-203	8
GUIDA DYNAPRO FRONT LOCKING DEVICE L_FBC_F134108955 4D	2
GUIDA DYNAPRO ADJUSTMENT ADAPTER L_FBC_F134141746 4D	2
GUIDA DYNAPRO SOFTCLOSE L400 L_FBC_F130107808 4D	2
GUIDA DYNAPRO FRONT LOCKING DEVICE R_FBC_F134108955 4D	2
GUIDA DYNAPRO ADJUSTMENT ADAPTER R_FBC_F134141746 4D	2
GUIDA DYNAPRO SOFTCLOSE L400 R_FBC_F130107808 4D	2
VITE 6MA X 25 TESTA BOMBATA NERA BHCS 10.9 ISO 7380	8
VITE 4MA X 10 TESTA SVASATA ESAGONALE NERA	4
ALZAPAGLIOLI_FORESTI_164.B BRUNITON	2
BUSSOLA 6MA X 10 FORO DIAM.8	14

LOCALE	CODICE	DESCRIZIONE COMPONENTE	FINITURA	GR.
CABINA ARMATORE	MD320_AV01	PLENUM ARMADIO PRUA	GREZZO VERNICIATO ANTI ROMBO	2

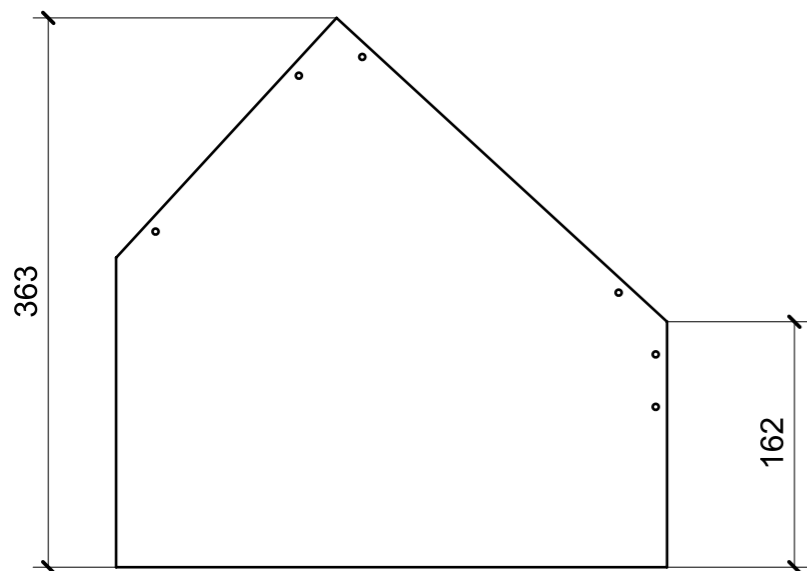
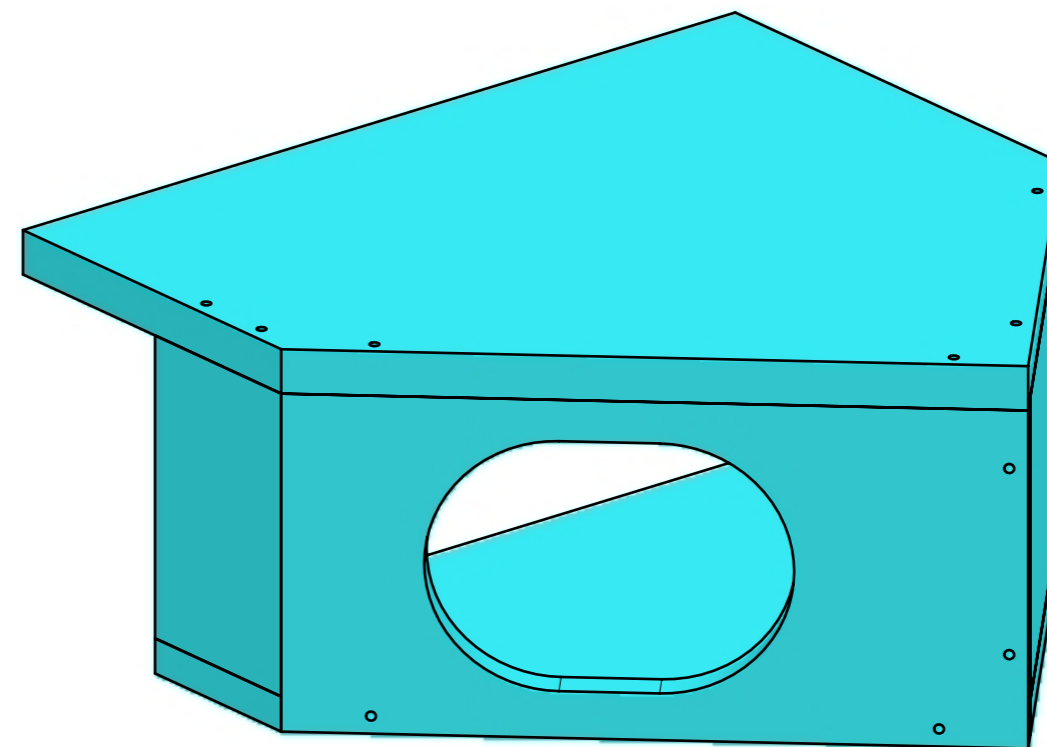
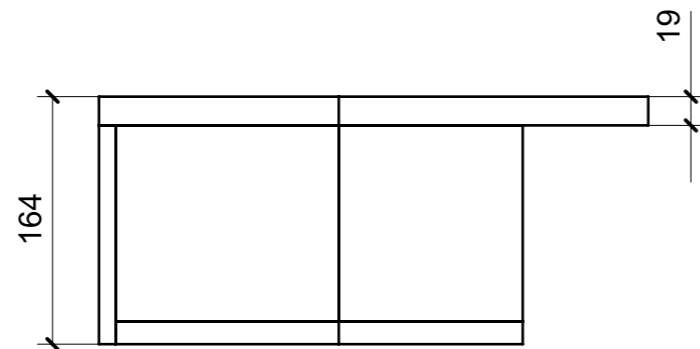
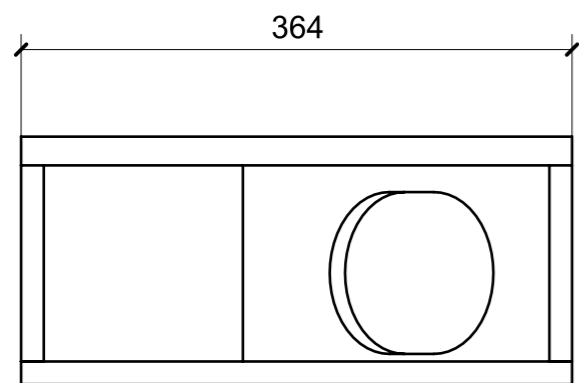

FERRAMENTA	QTY
BUSSOLA 6MA X 10 FORO DIAM.8	2

LOCALE	CODICE	DESCRIZIONE COMPONENTE	FINITURA	GR.
CABINA ARMATORE	MD320_AW01	STRUTTURA VANO PORTA SCORREVOLE	OKOUME' GREZZO	PTP

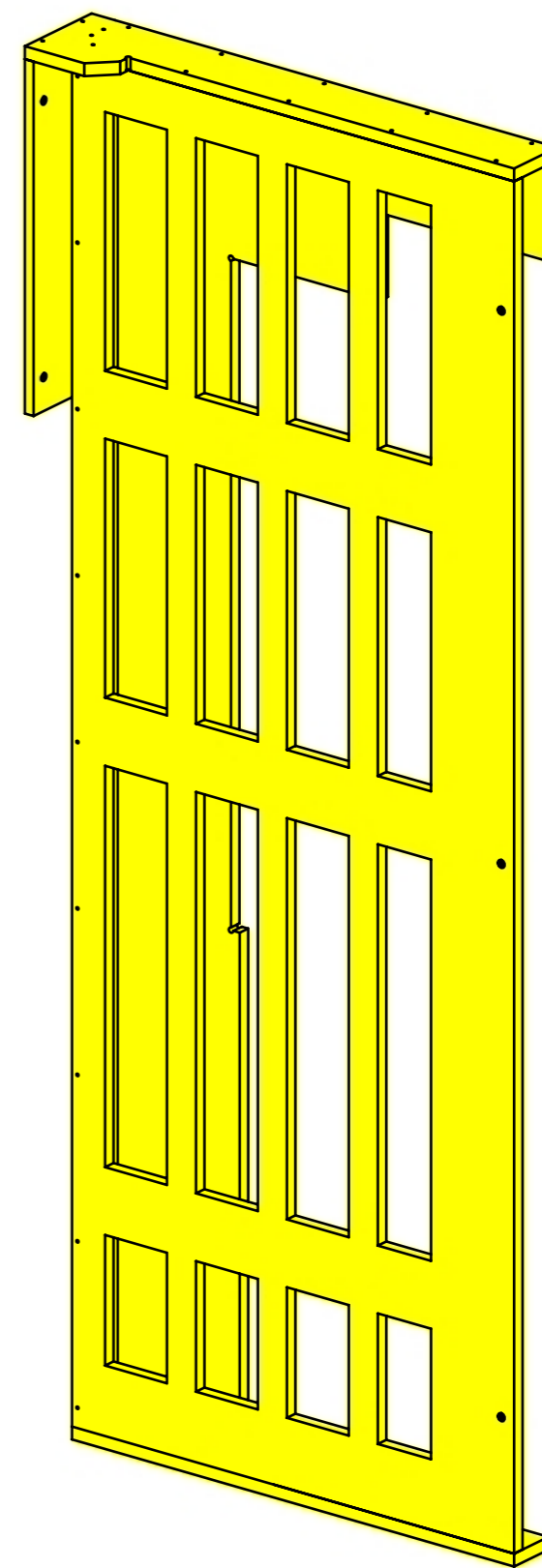
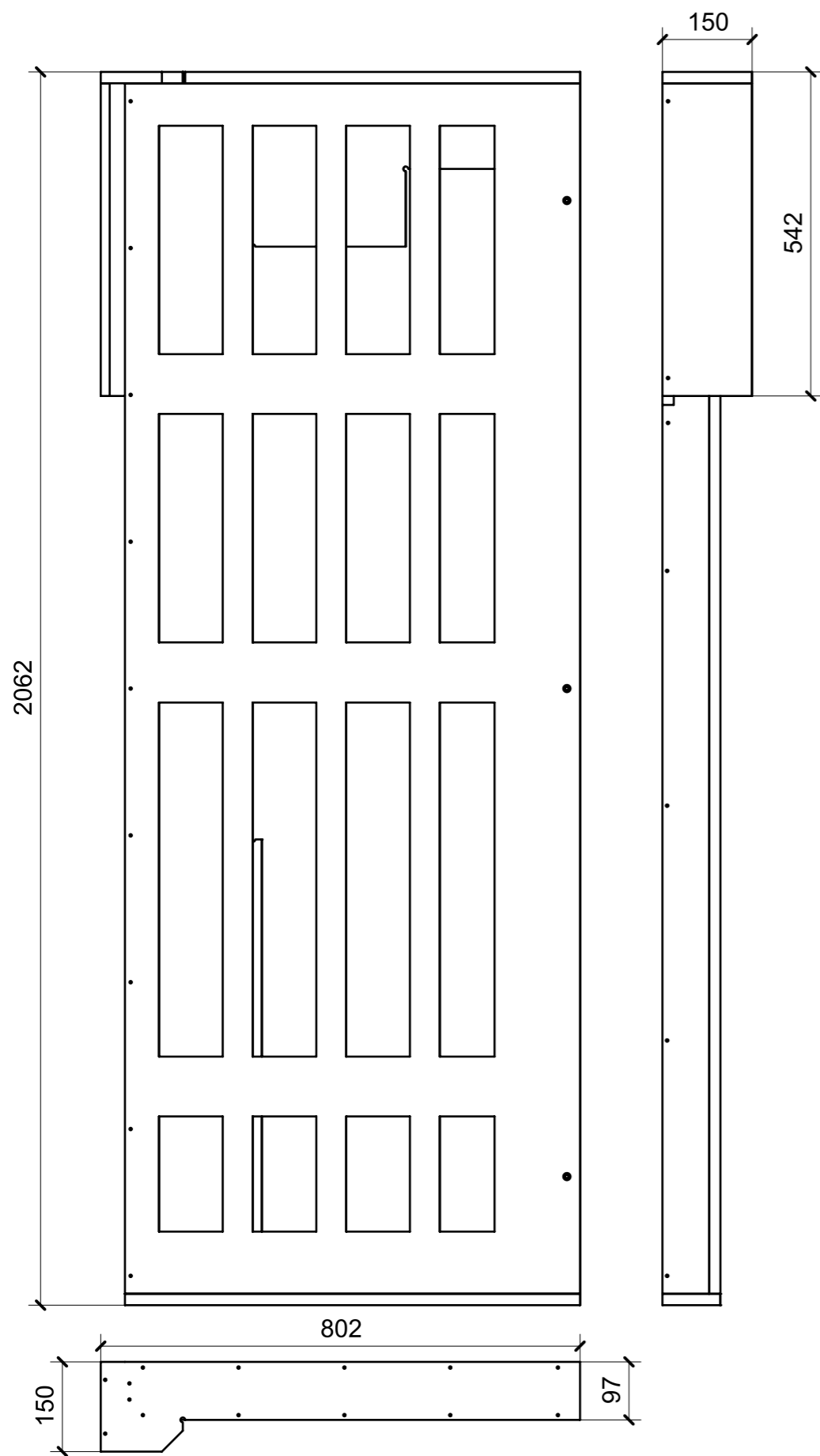

LOCALE	CODICE	DESCRIZIONE COMPONENTE	FINITURA	GR.
CABINA ARMATORE	MD320_AY01	CIELINO MURATA PRUA DX VAR 1-VAR 2	CARTA MELAMINICA NERA	3

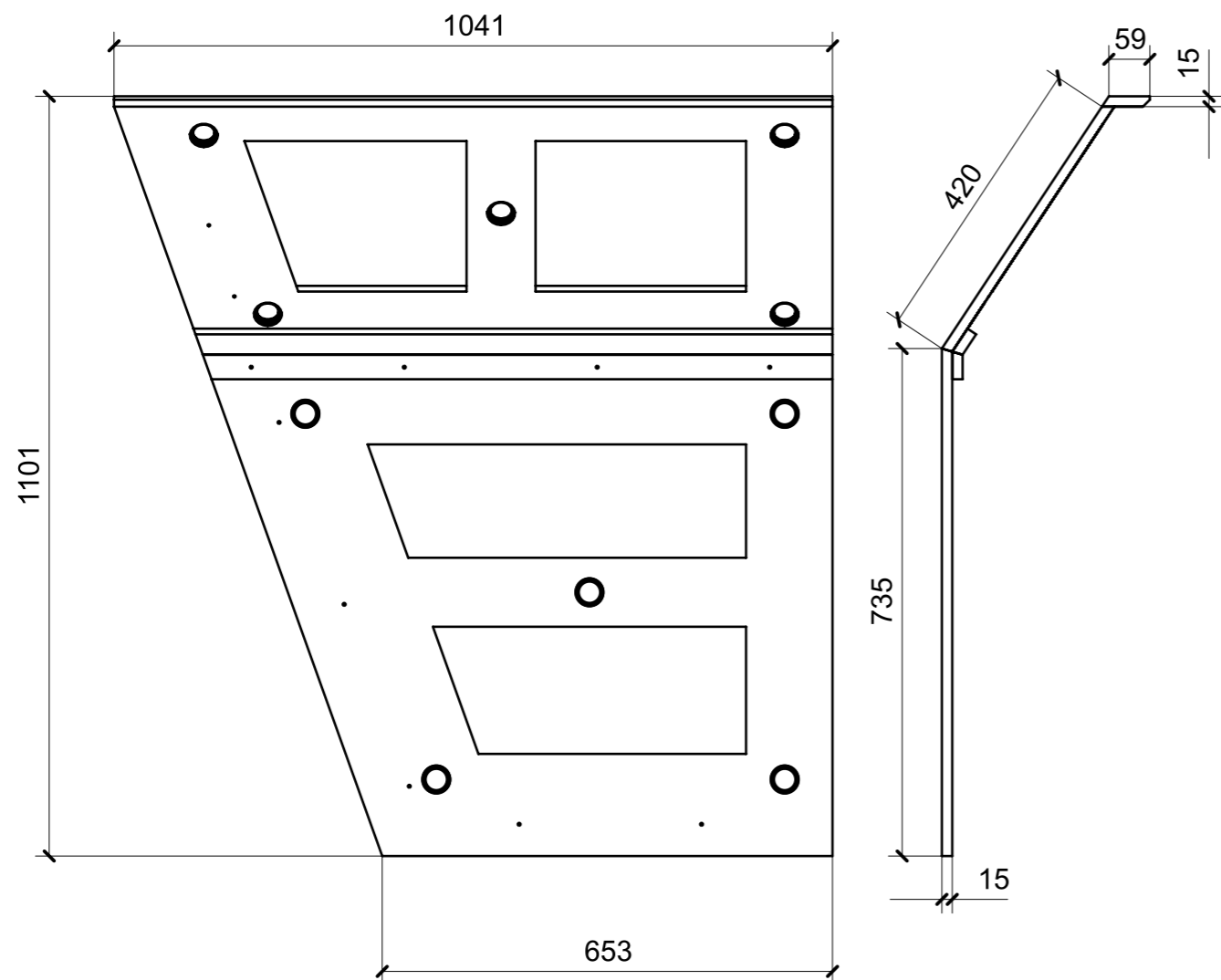
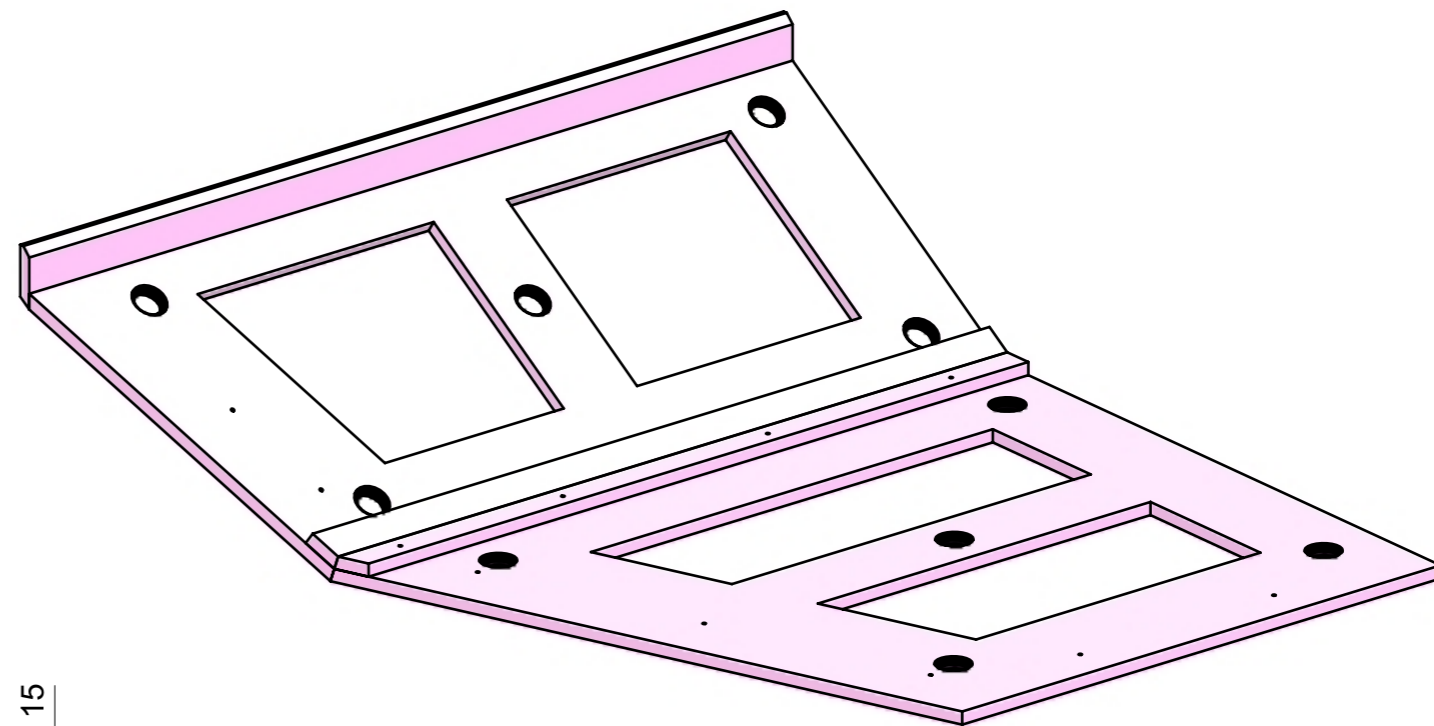

FERRAMENTA	QTY
FITLOCK F_MASCHERPA_6020101102	10

VERNICIATURA LASTRA/LACCATI:

● = FILI RASATI

● = VERNICIARE 1 LATO + FILI RASATI O BORDATI

NESSUN SIMBOLO = VERNICIARE 2 LATI + FILI RASATI O BORDATI

LOCALE	CODICE	DESCRIZIONE COMPONENTE	FINITURA	GR.
CABINA ARMATORE	MD320_AAY01	CIELINO MURATA PRUA DX VAR 3-VAR 4	CARTA MELAMINICA NERA	3

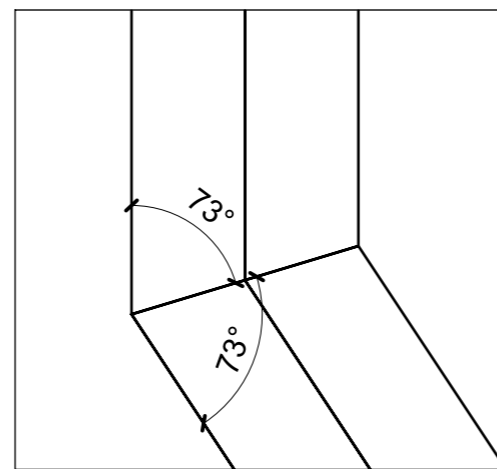
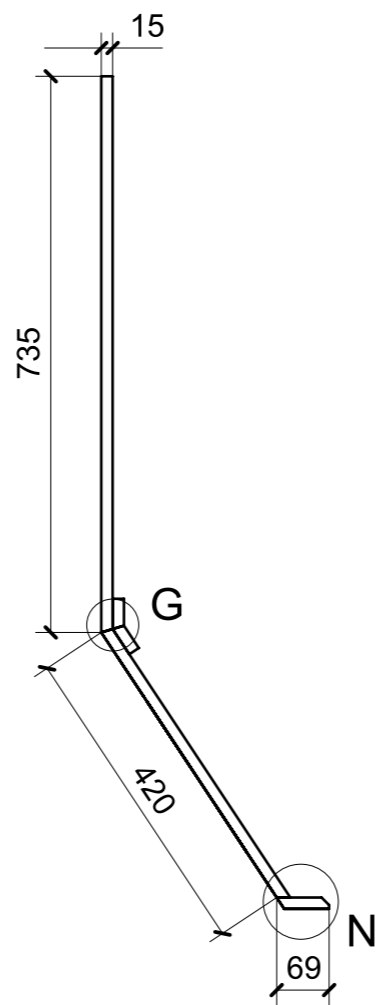
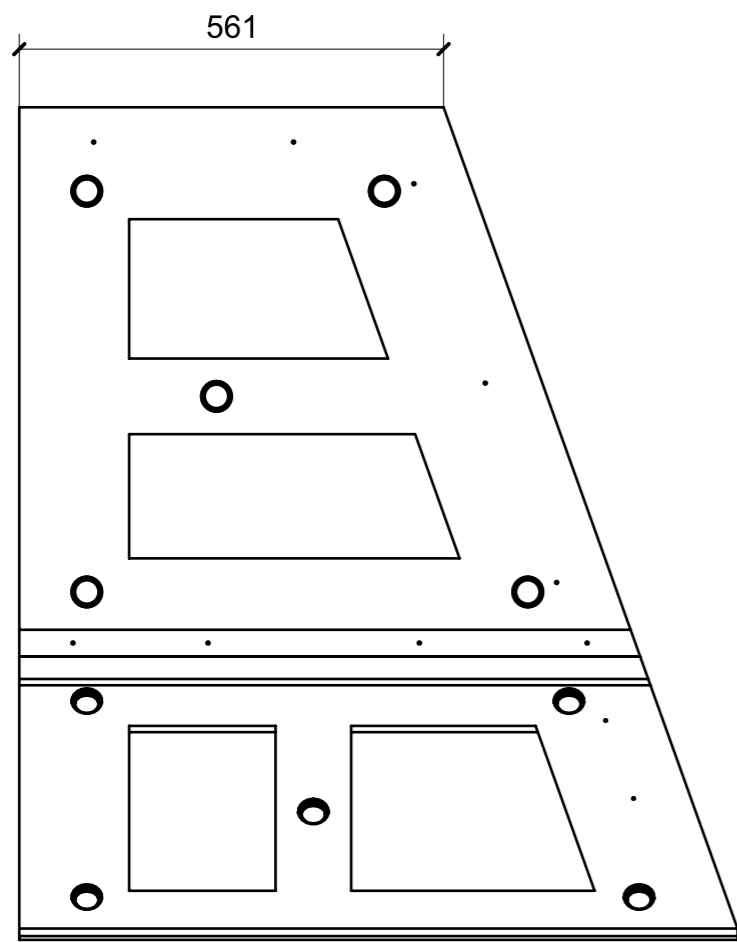

DETAIL G  
SCALE 1:1

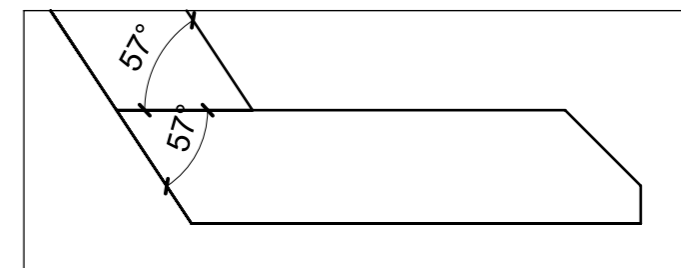

DETAIL N  
SCALE 1:1

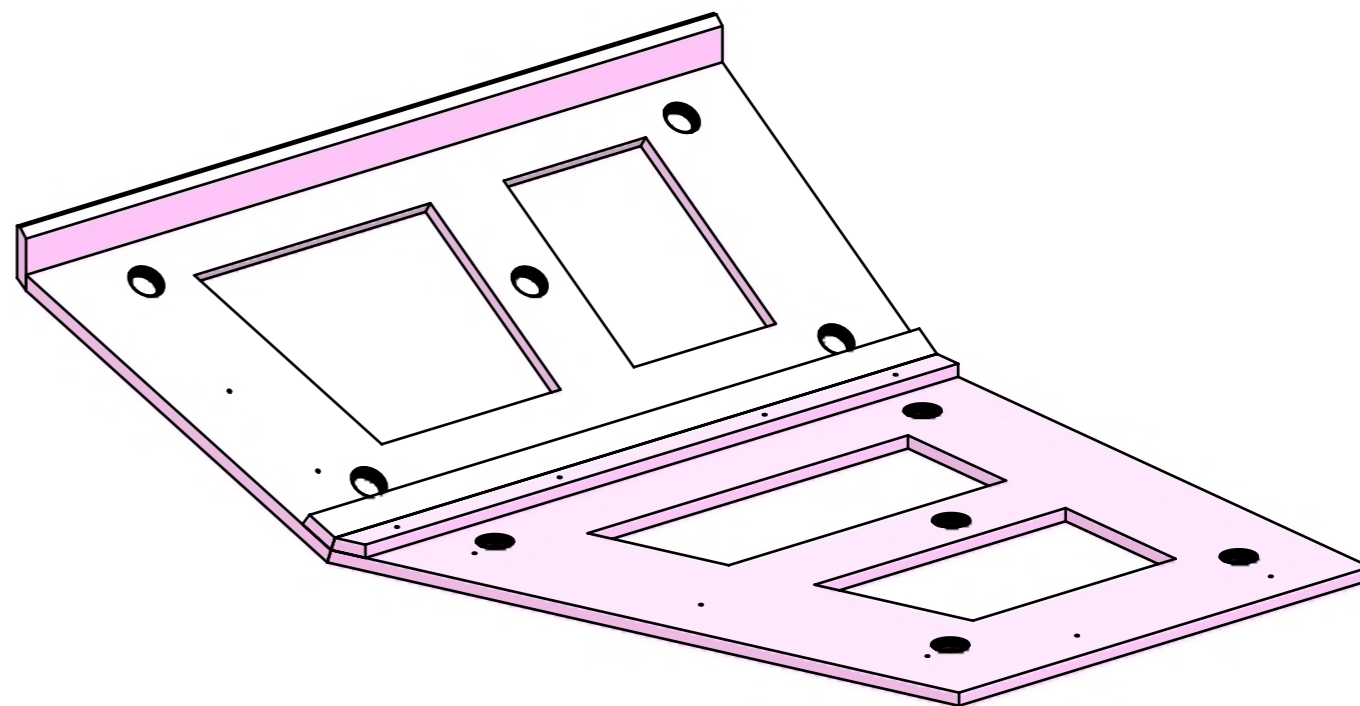
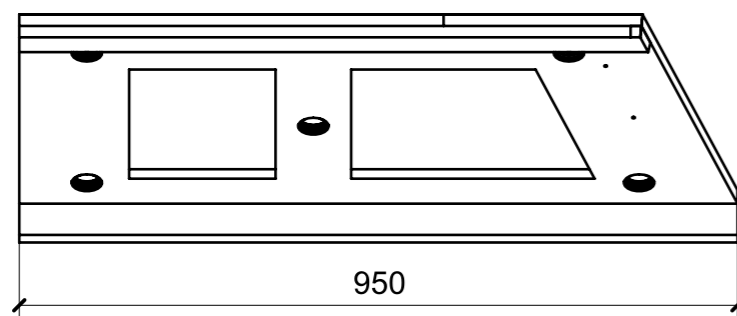

FERRAMENTA	QTY
FITLOCK F_MASCHERPA_6020101102	10

LOCALE	CODICE	DESCRIZIONE COMPONENTE	FINITURA	GR.
CABINA ARMATORE	MD320_AZ01	TAVOLO VANITY OPT	LAMINATO SMART 0180-2 JUNGLE/OKUME' GREZZO	4

ELEMENTO DA MONTARE in MF\_AZ01  
e spedire con unico imballo

