

LOCALE	CODICE	DESCRIZIONE COMPONENTE	FINITURA	Q.TA
CABINA ARMATORE	MD299_I01_AC01	PONTE AC MURATA SX	OKUME' GREZZO	1

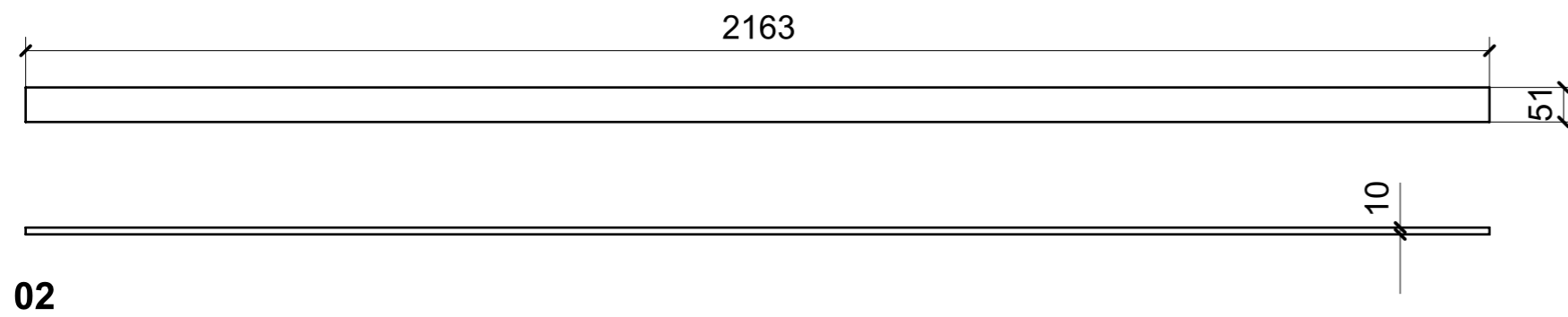

LOCALE	CODICE	DESCRIZIONE COMPONENTE	FINITURA	Q.TA
CABINA ARMATORE	MD299_I01_AE01	RIVESTIMENTO PARETE TV	OKUME' GREZZO	1

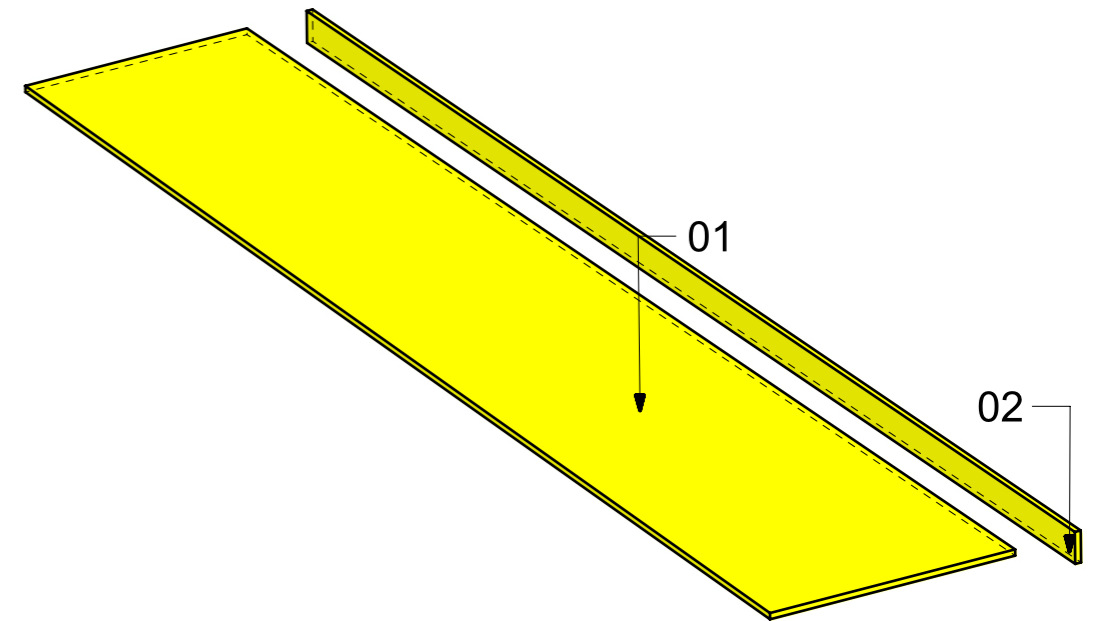
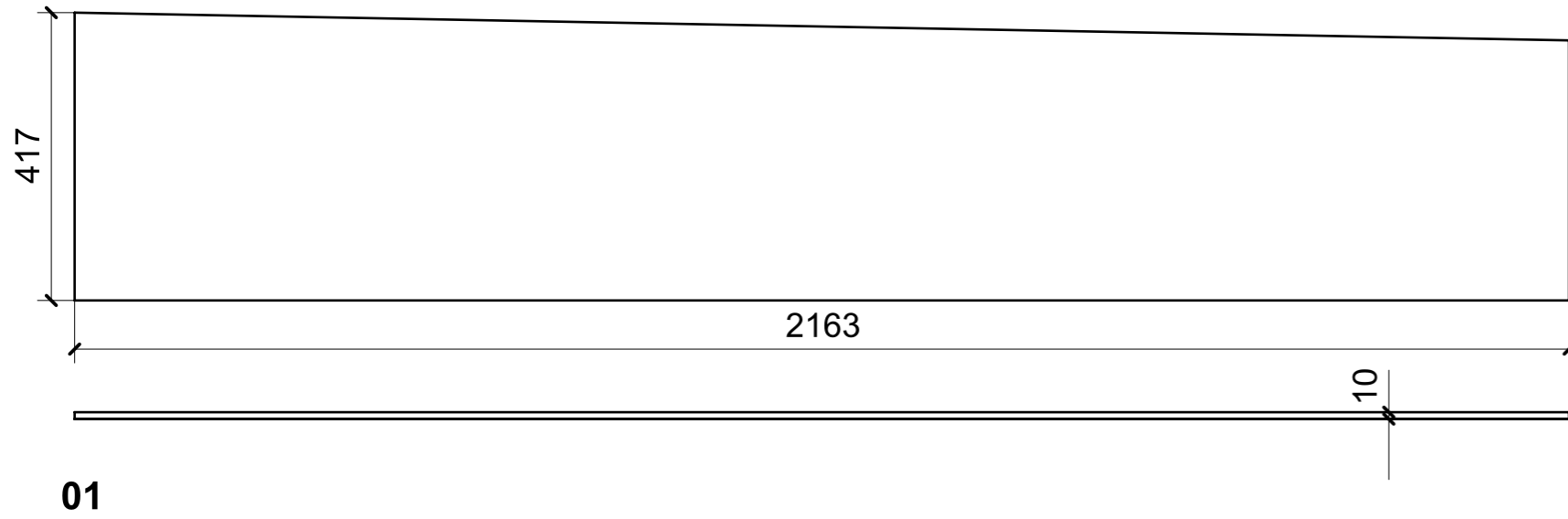
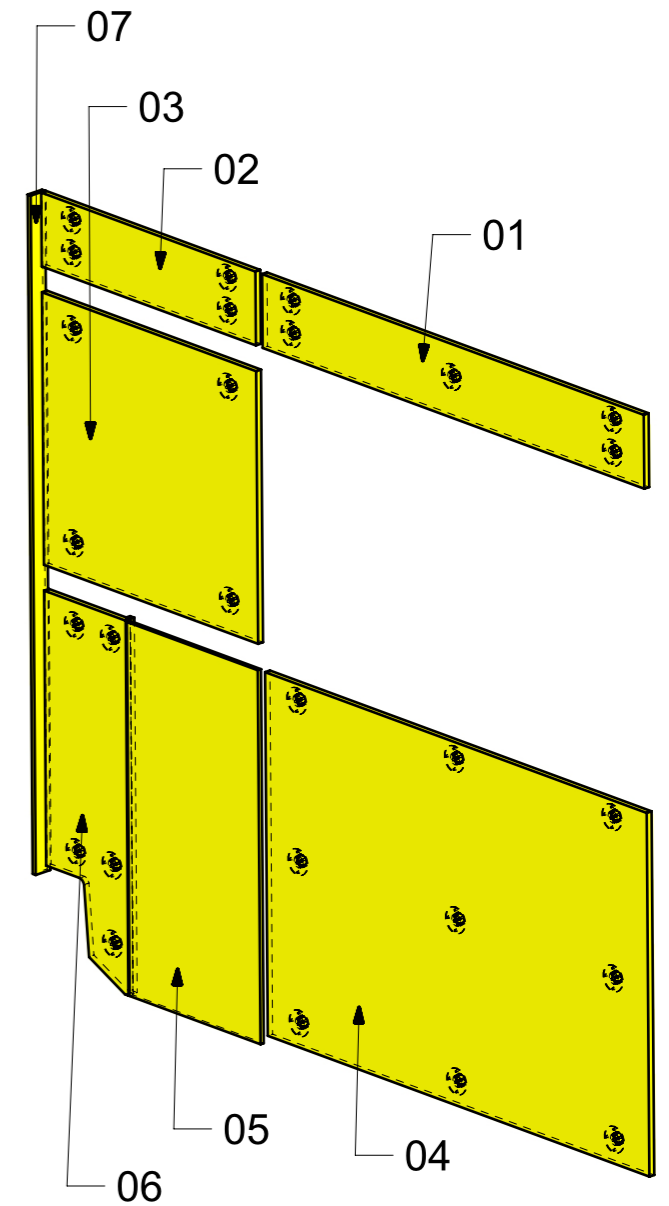
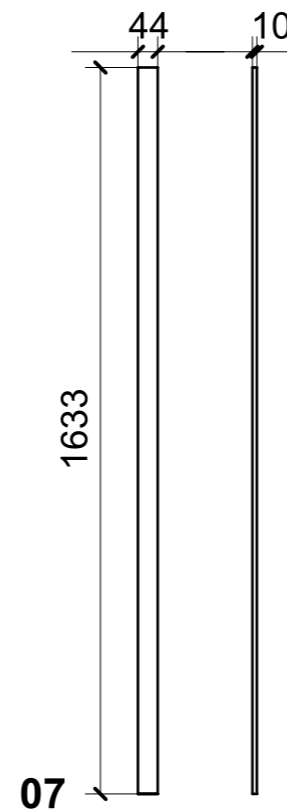
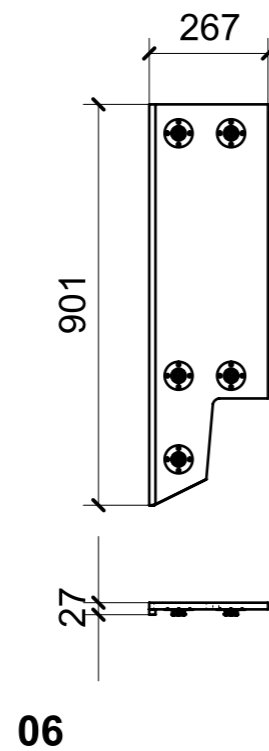
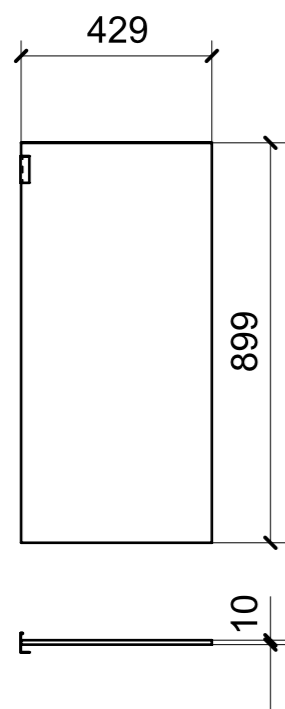
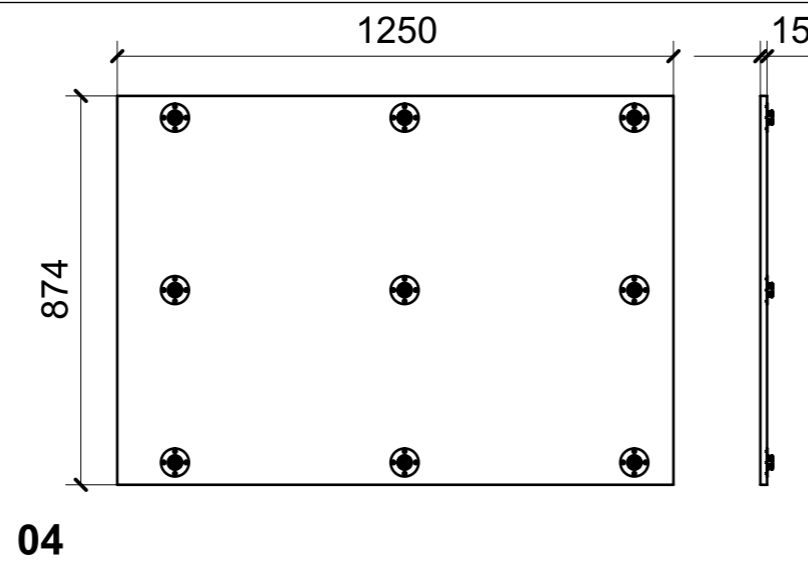
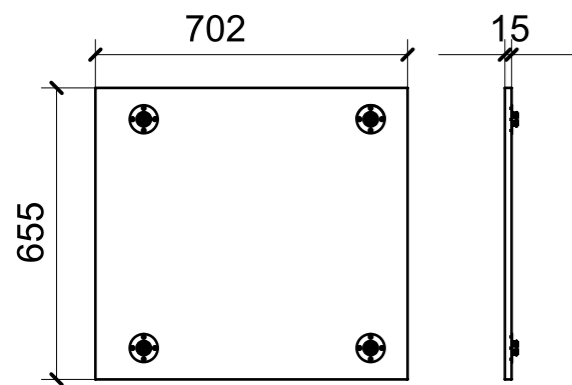
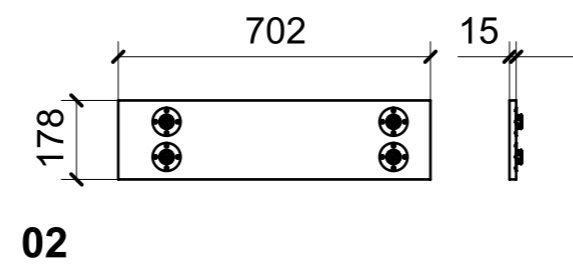
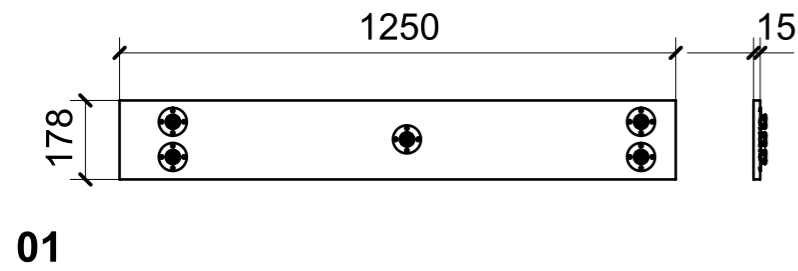

FERRAMENTA	QTY
MANIGLIA ALLUMINIO BIANCA_FBC BORGHI_3620C	1
FITLOCK M_MASCHERPA_3MM_6020202101	27

LOCALE	CODICE	DESCRIZIONE COMPONENTE	FINITURA	Q.TA
CABINA ARMATORE	MD299_I01_AF01	STRUTTURA RIV. BAGNO OSPITI DX	OKUME' GREZZO	1

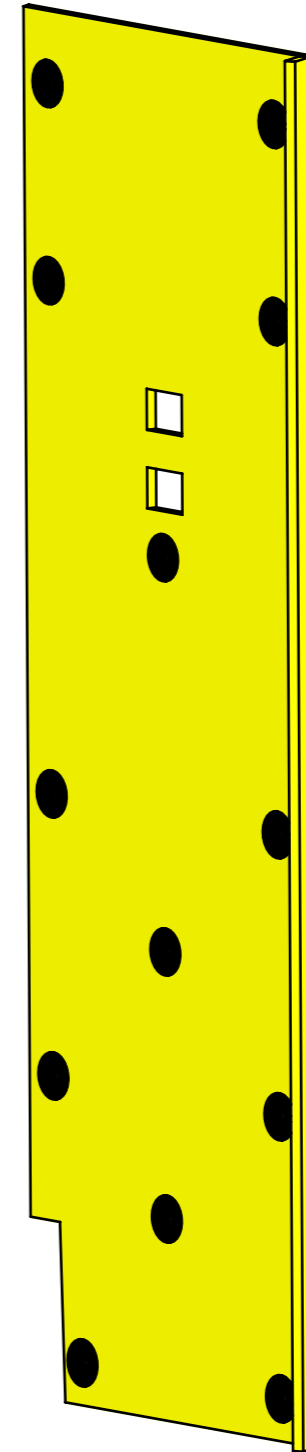
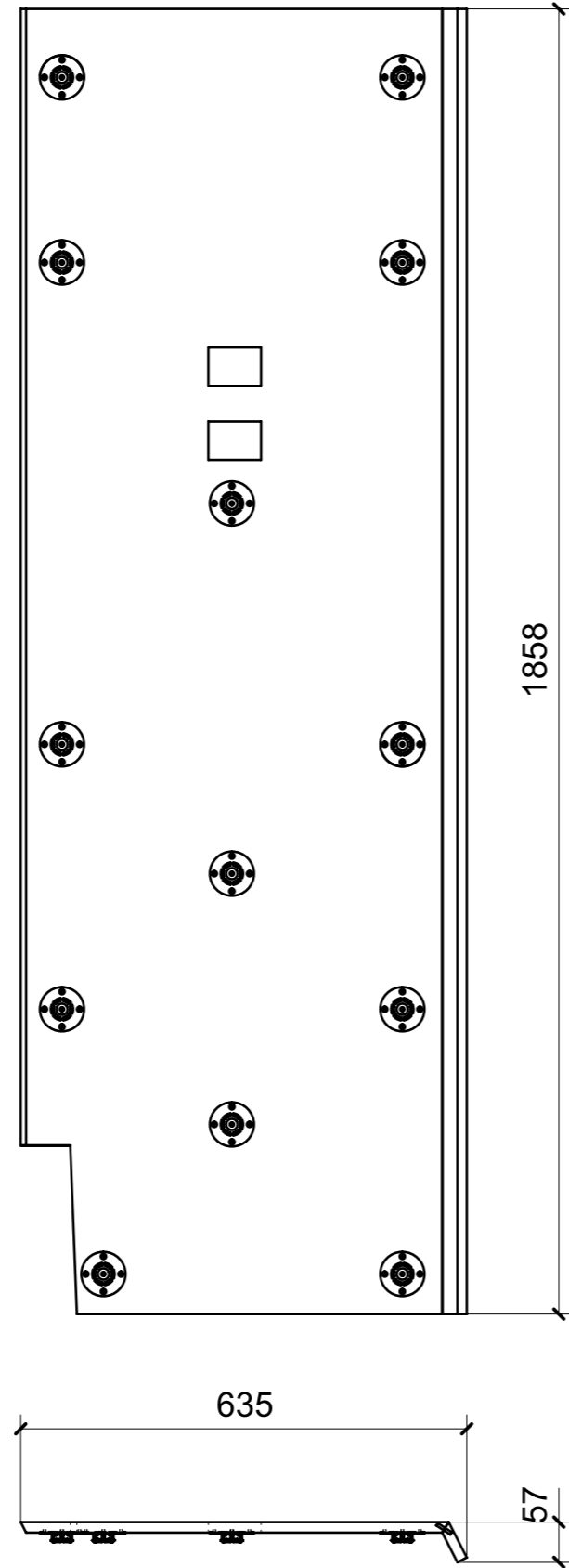

FERRAMENTA	QTY
FITLOCK M_MASCHERPA_3MM_6020202101	13

LOCALE	CODICE	DESCRIZIONE COMPONENTE	FINITURA	Q.TA
CABINA ARMATORE	MD299_I01_AI01	PONTE AC MURATA DX	OKUME' GREZZO	1

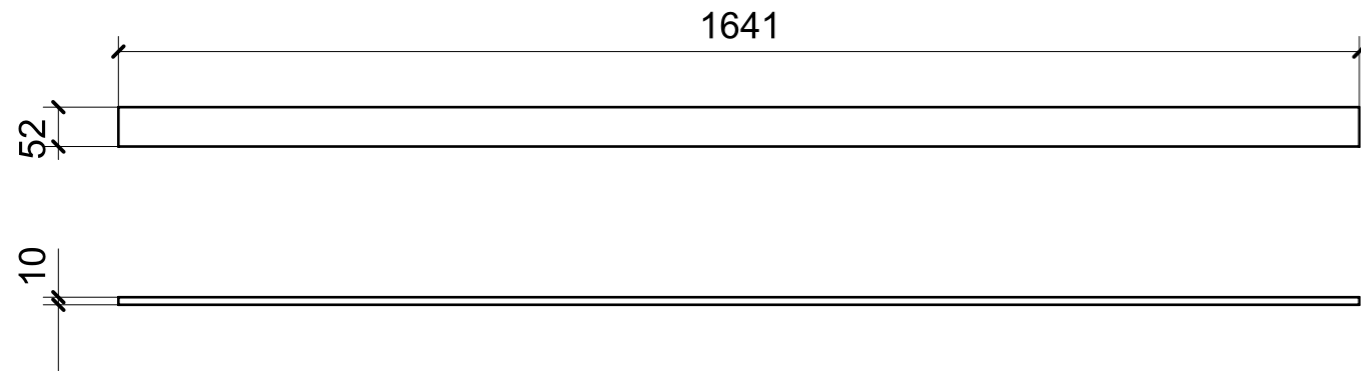

01

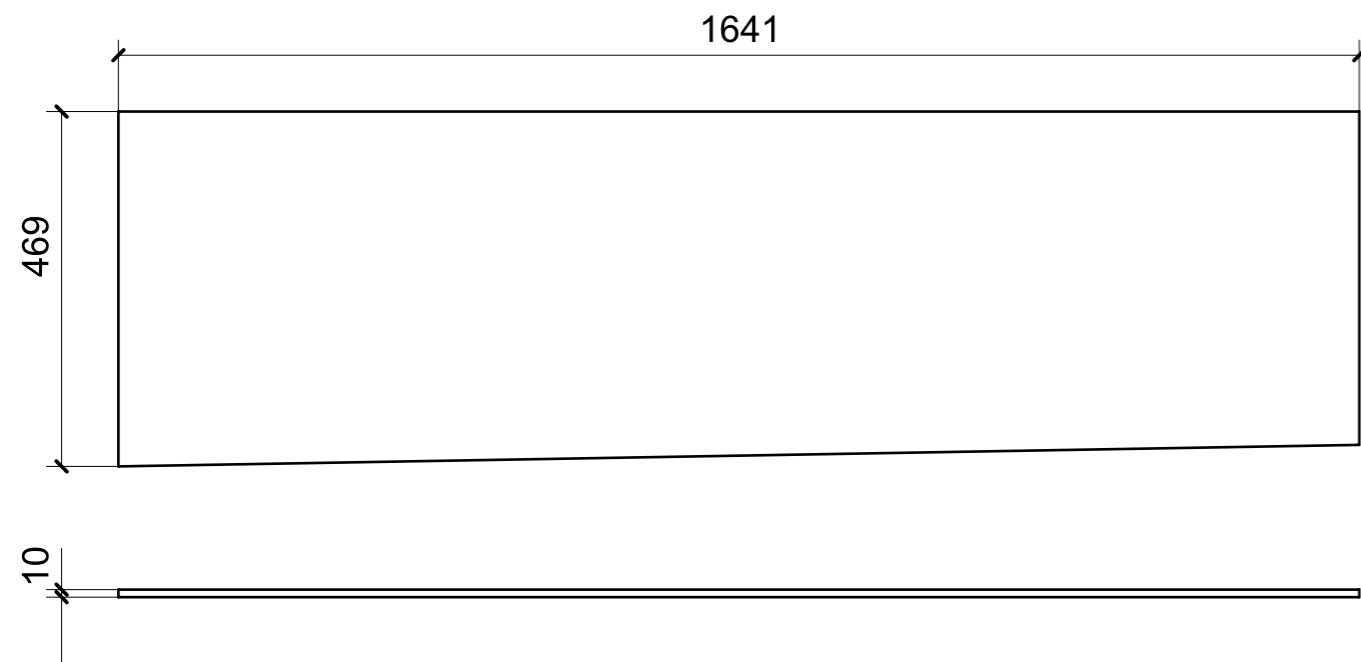
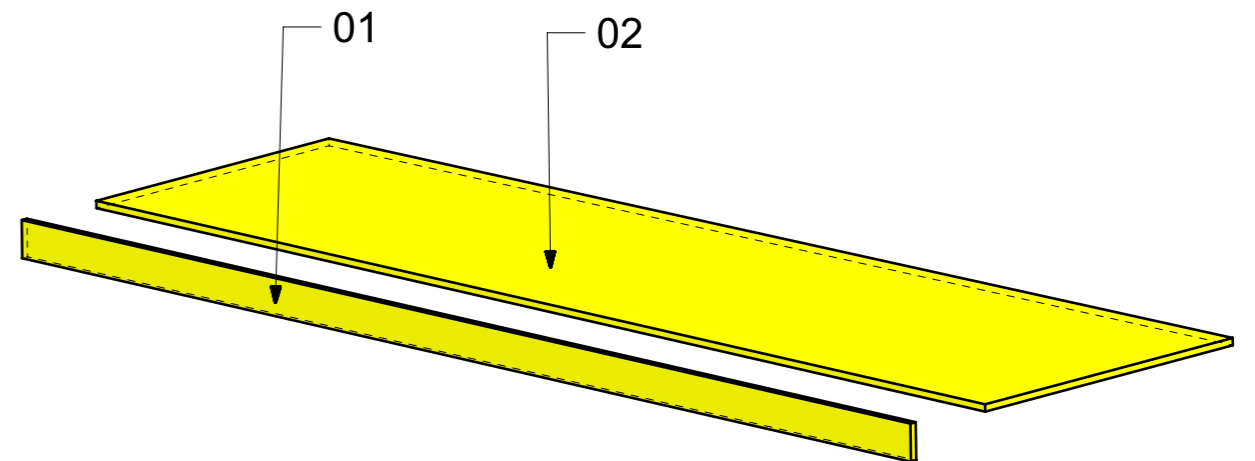

02

LOCALE	CODICE	DESCRIZIONE COMPONENTE	FINITURA	GR.
CABINA ARMATORE	MD320_I01_AJ01	RIV. COLONNA SX VAR 1	OKUME' GREZZO	9

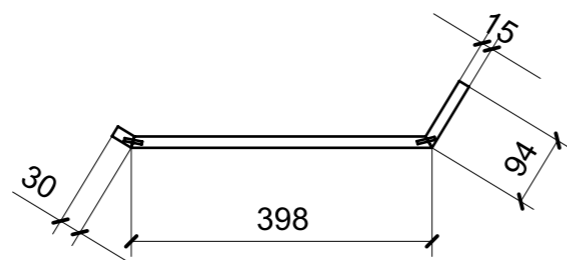
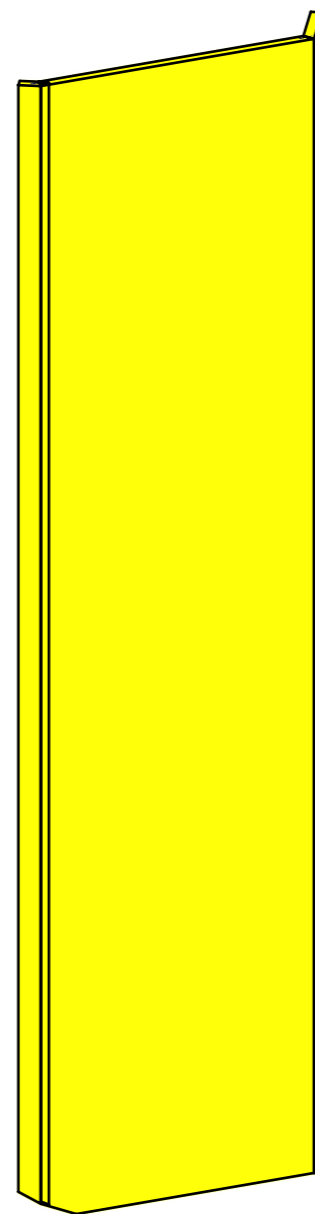
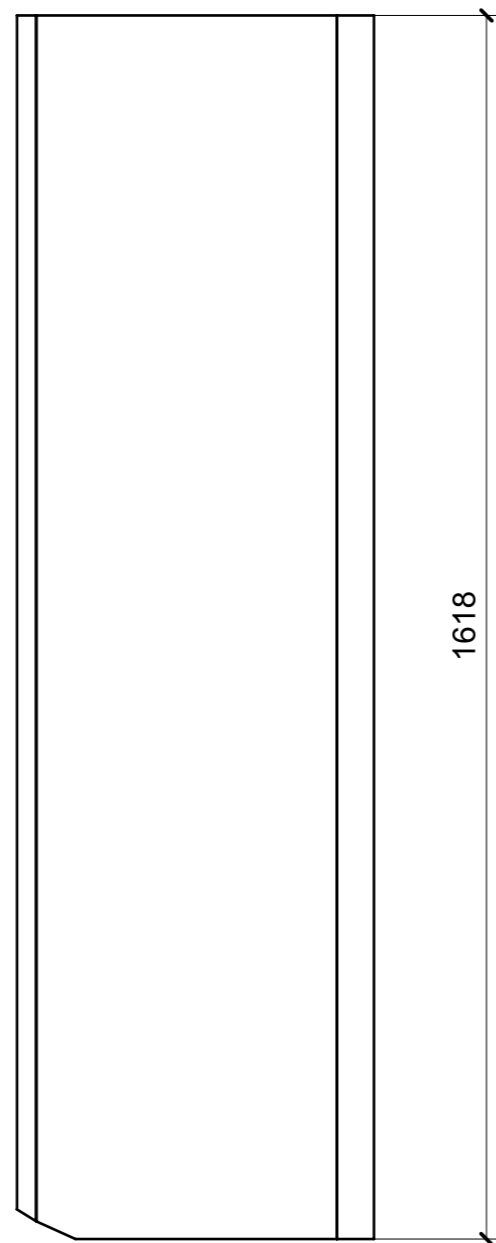

LOCALE	CODICE	DESCRIZIONE COMPONENTE	FINITURA	Q.TA
CABINA ARMATORE	MD299_I01_AM01	CORNICE OBLO SX	OKUME' GREZZO	1

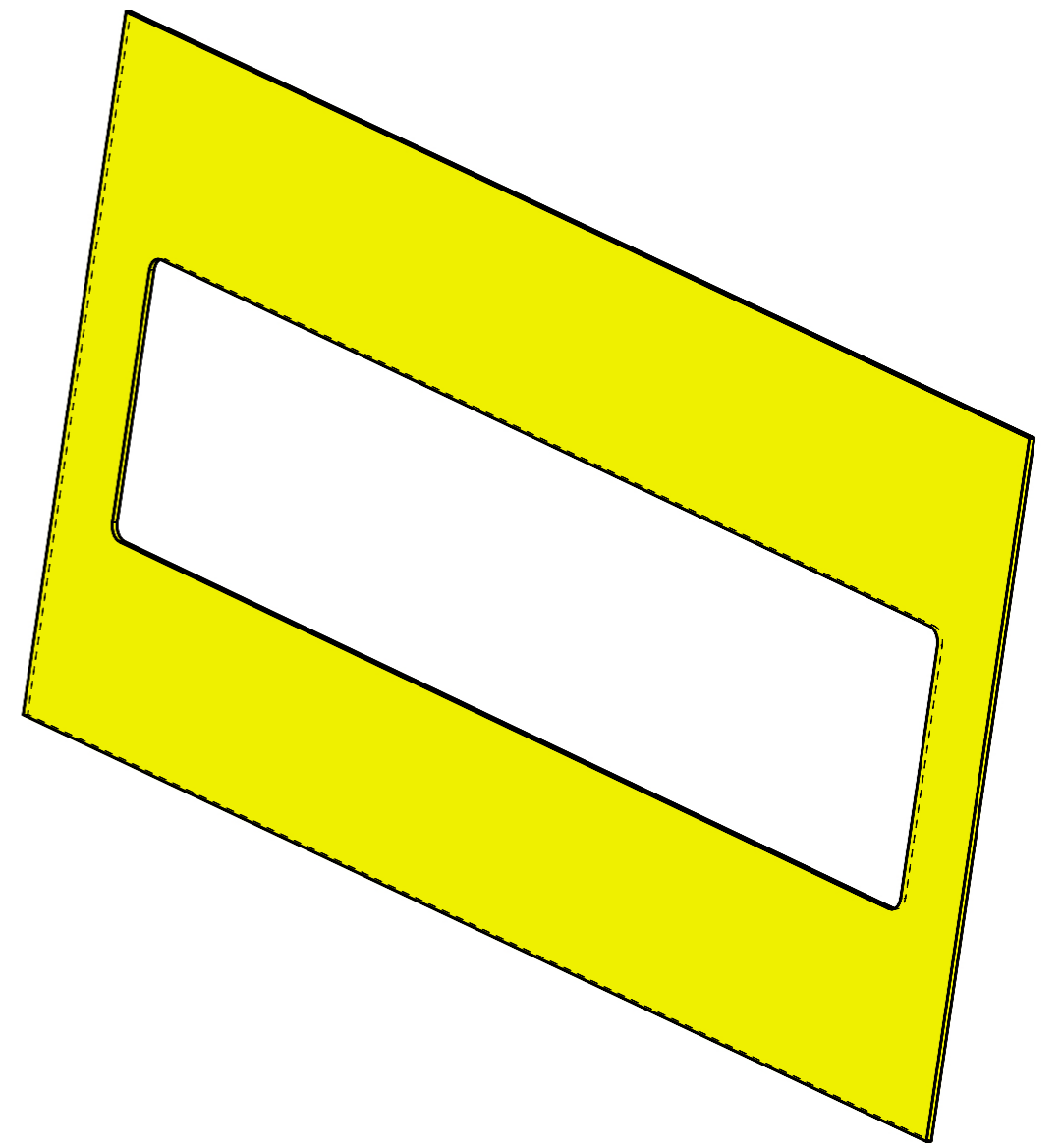
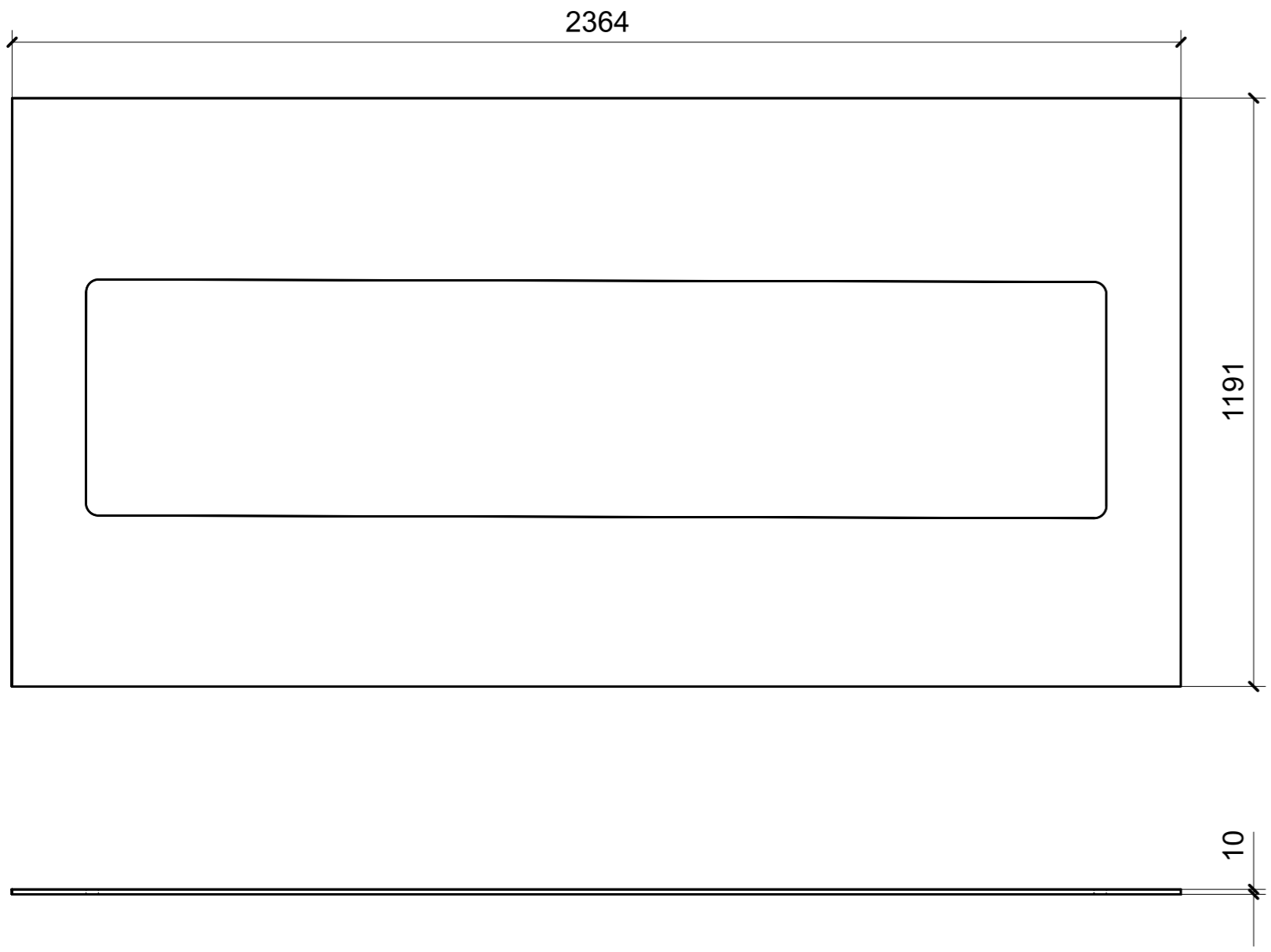

LOCALE	CODICE	DESCRIZIONE COMPONENTE	FINITURA	Q.TA
CABINA ARMATORE	MD299_I01_AN01	CORNICE OBLO DX	OKUME' GREZZO	1

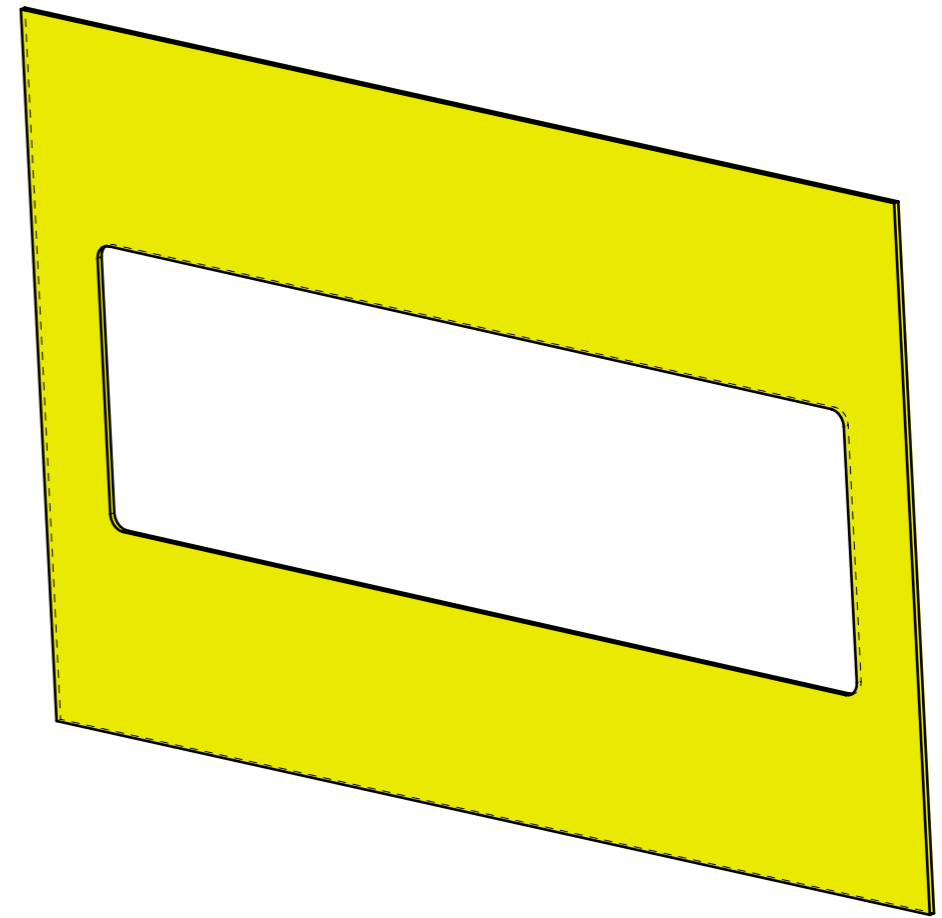
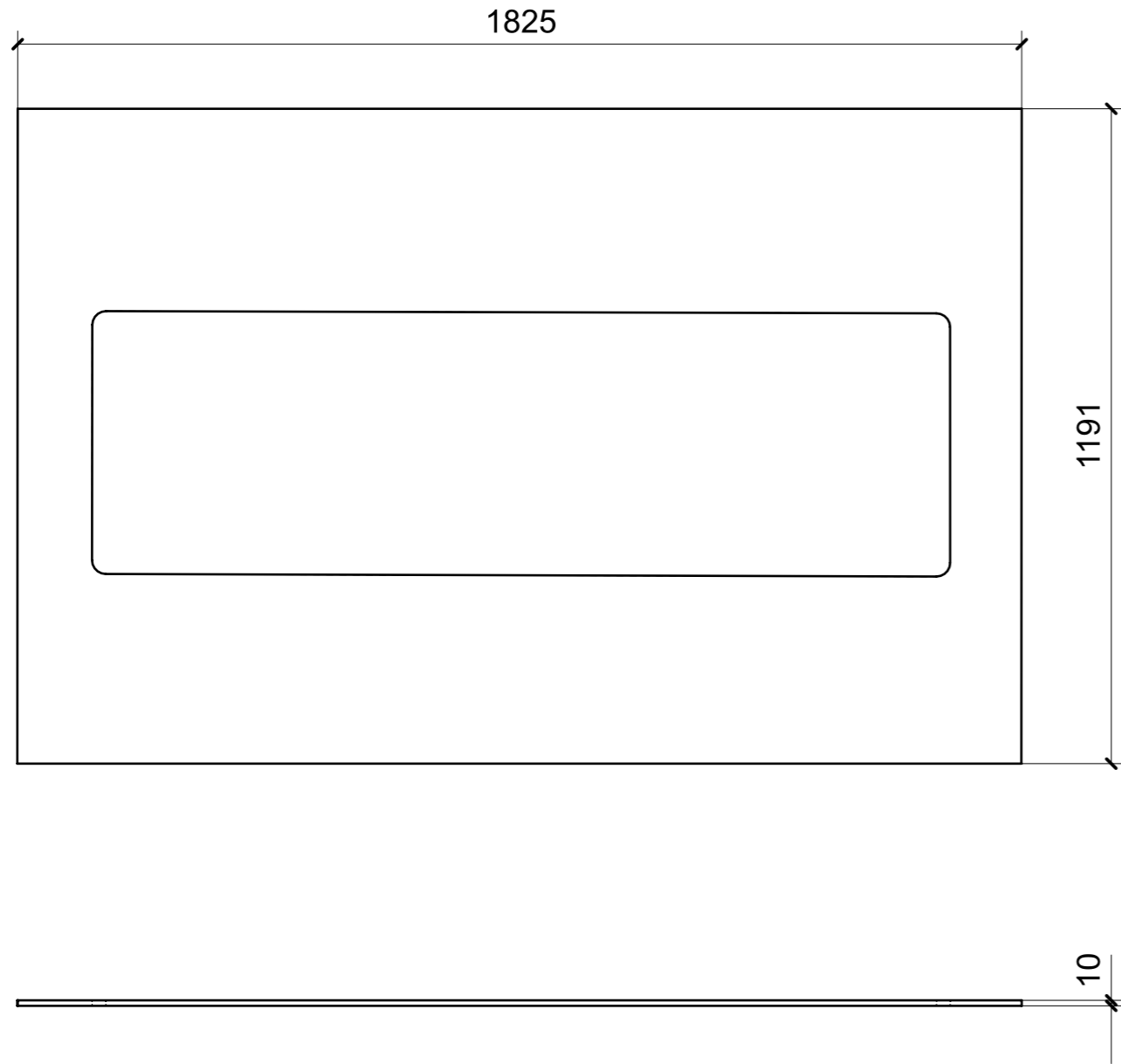

LOCALE	CODICE	DESCRIZIONE COMPONENTE	FINITURA	Q.TA
CABINA ARMATORE	MD299_I01_A001	STRUTTURA TESTALETTO	OKUME' GREZZO	1

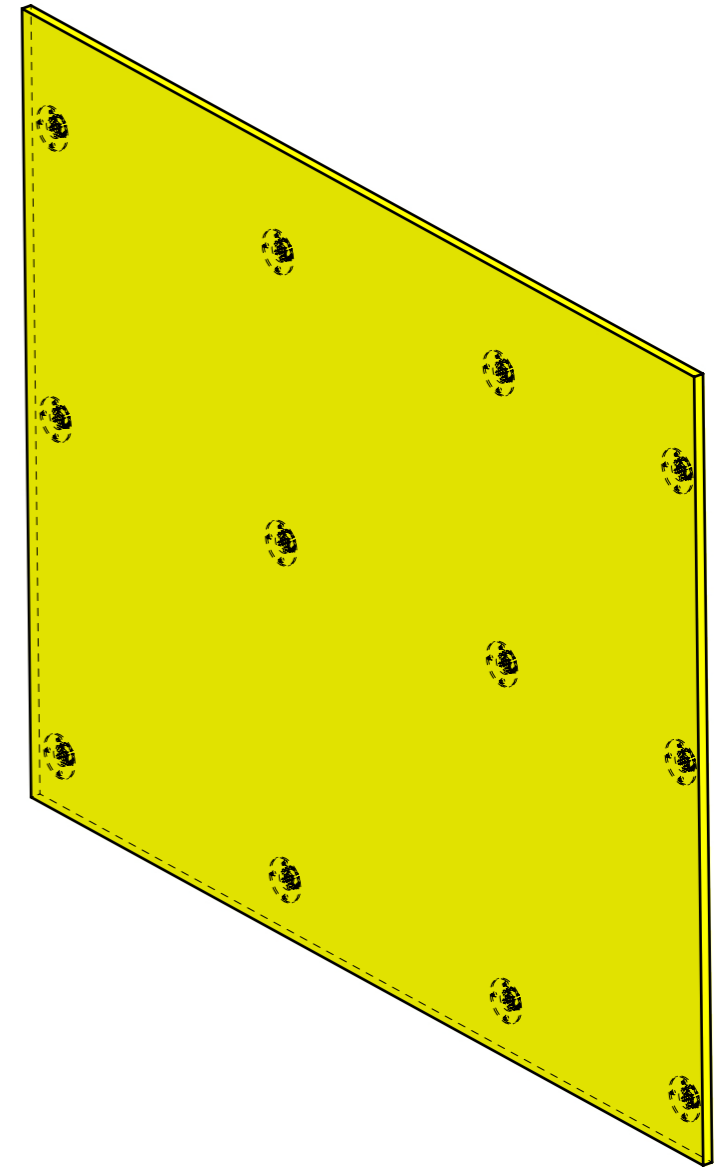
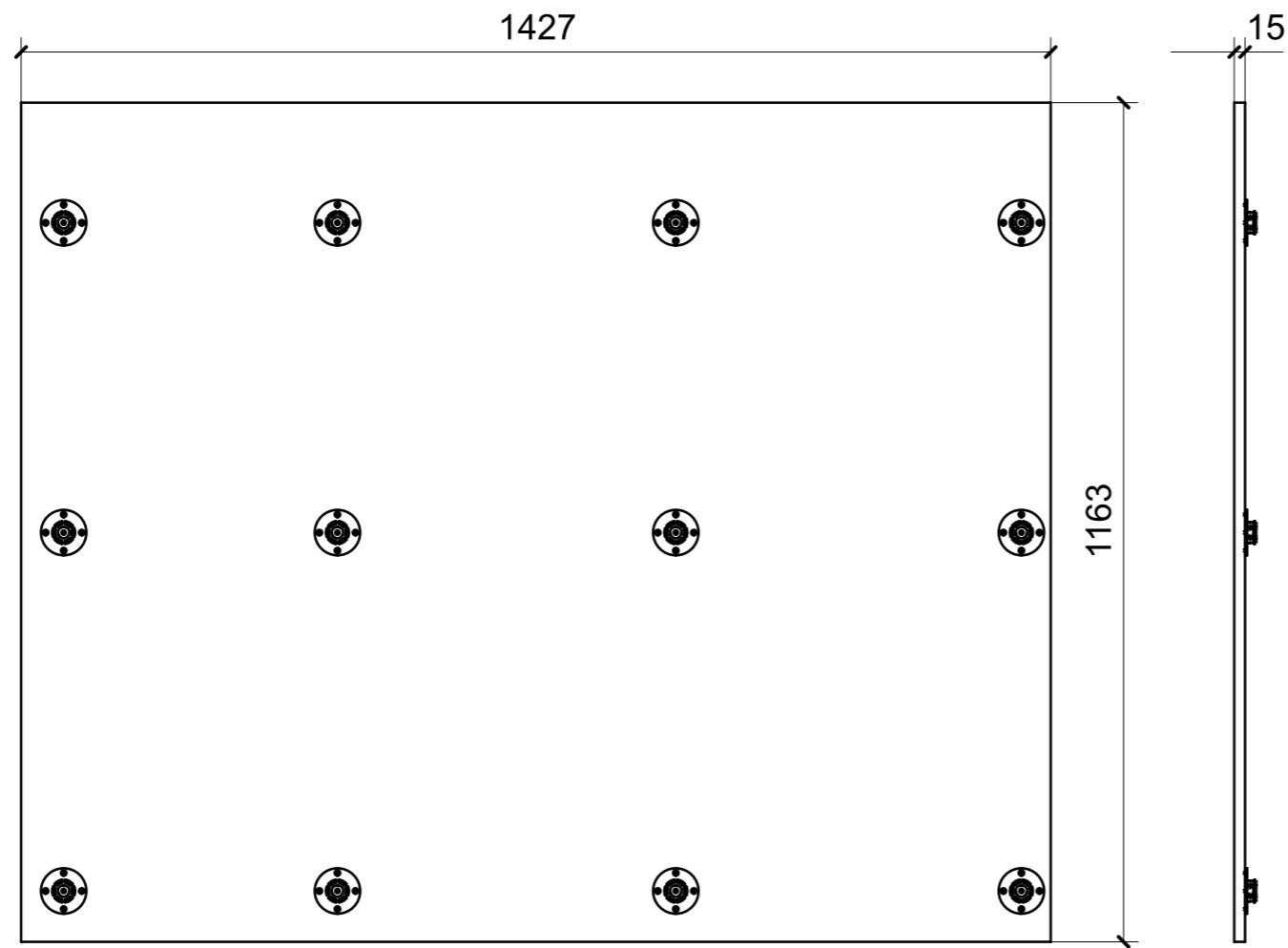

FERRAMENTA	QTY
FITLOCK M_MASCHERPA_3MM_6020202101	12

LOCALE	CODICE	DESCRIZIONE COMPONENTE	FINITURA	GR
CABINA ARMATORE	MD299_I01_AP01	LETTO_STD VAR.1	OKUME' GREZZO	12

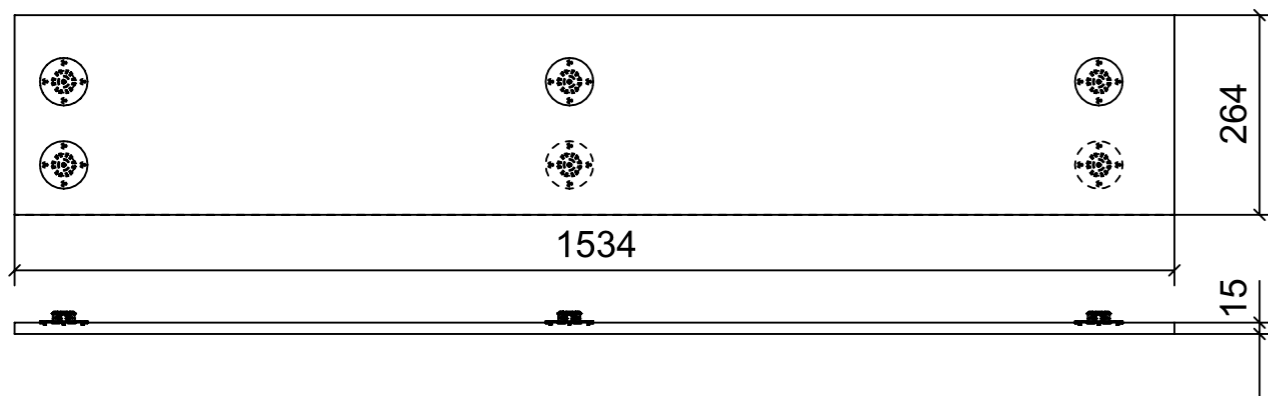

01

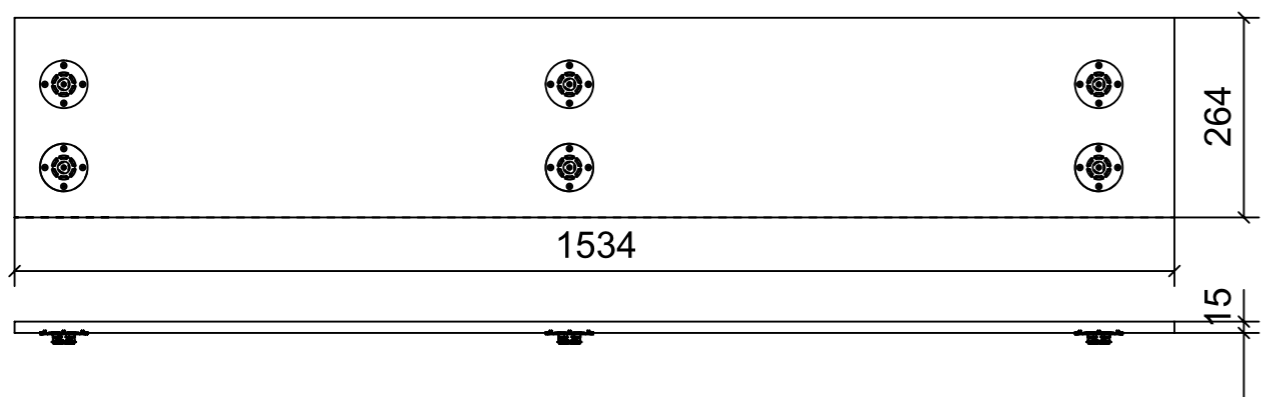

02

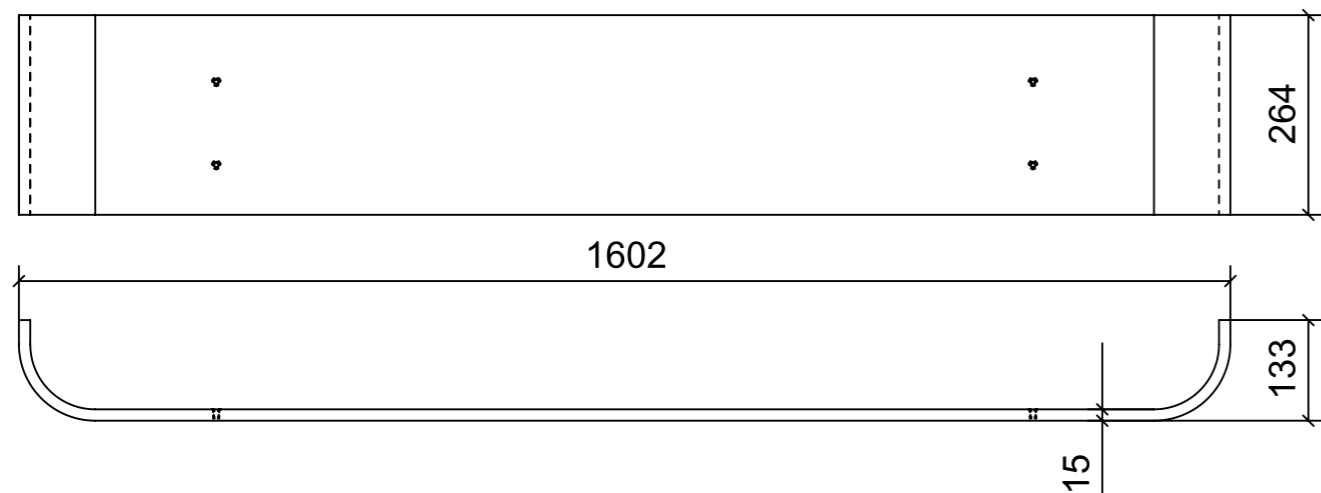

03

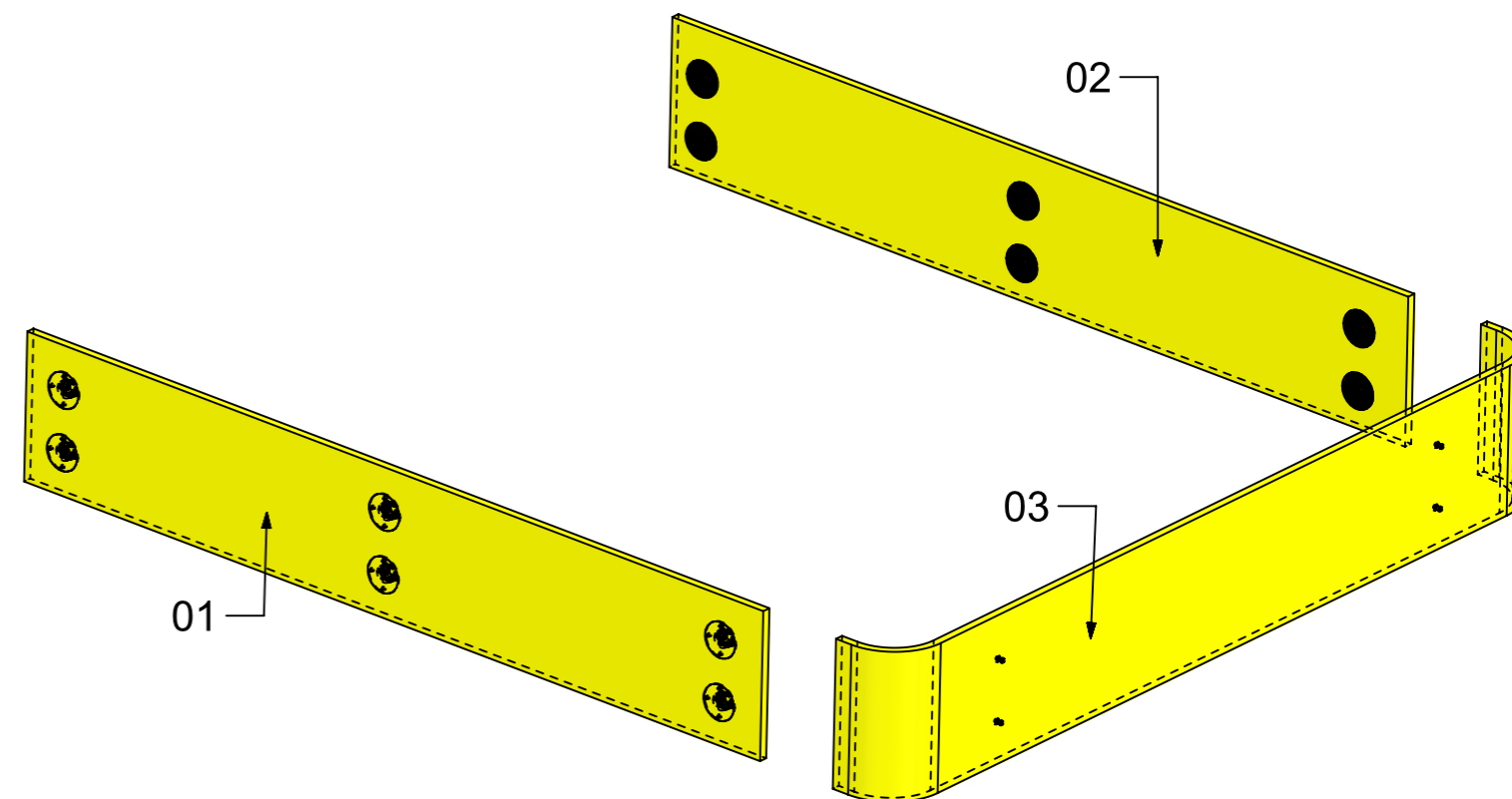

FERRAMENTA	QTY
BUSSOLA 6MA X 10 FORO DIAM.8	4
FITLOCK M_MASCHERPA_3MM_6020202101	12

LOCALE	CODICE	DESCRIZIONE COMPONENTE	FINITURA	Q.TA
CABINA ARMATORE	MD299_I01_AQ01	COMODINO SX_STD VAR 1	OKUME' GREZZO	1

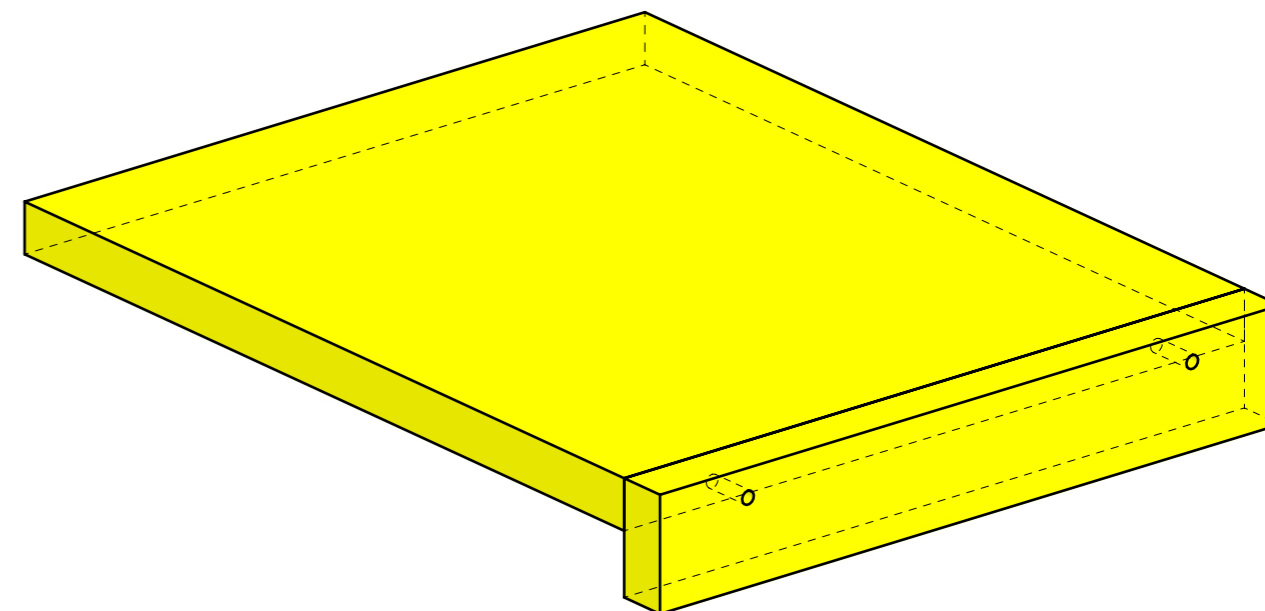
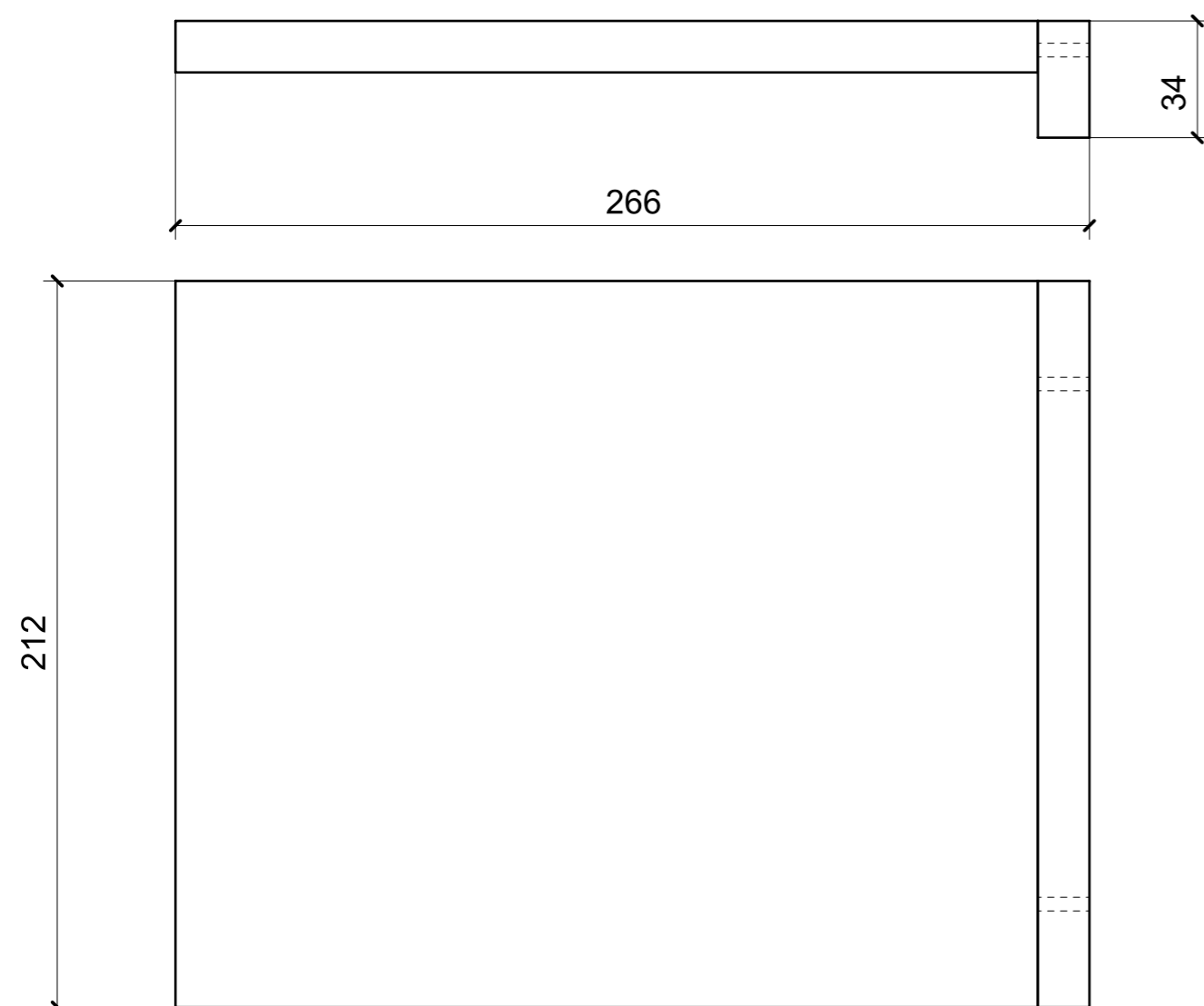

LOCALE	CODICE	DESCRIZIONE COMPONENTE	FINITURA	Q.TA
CABINA ARMATORE	MD299_I01_AR01	COMODINO DX_STD VAR 1	OKUME' GREZZO	1

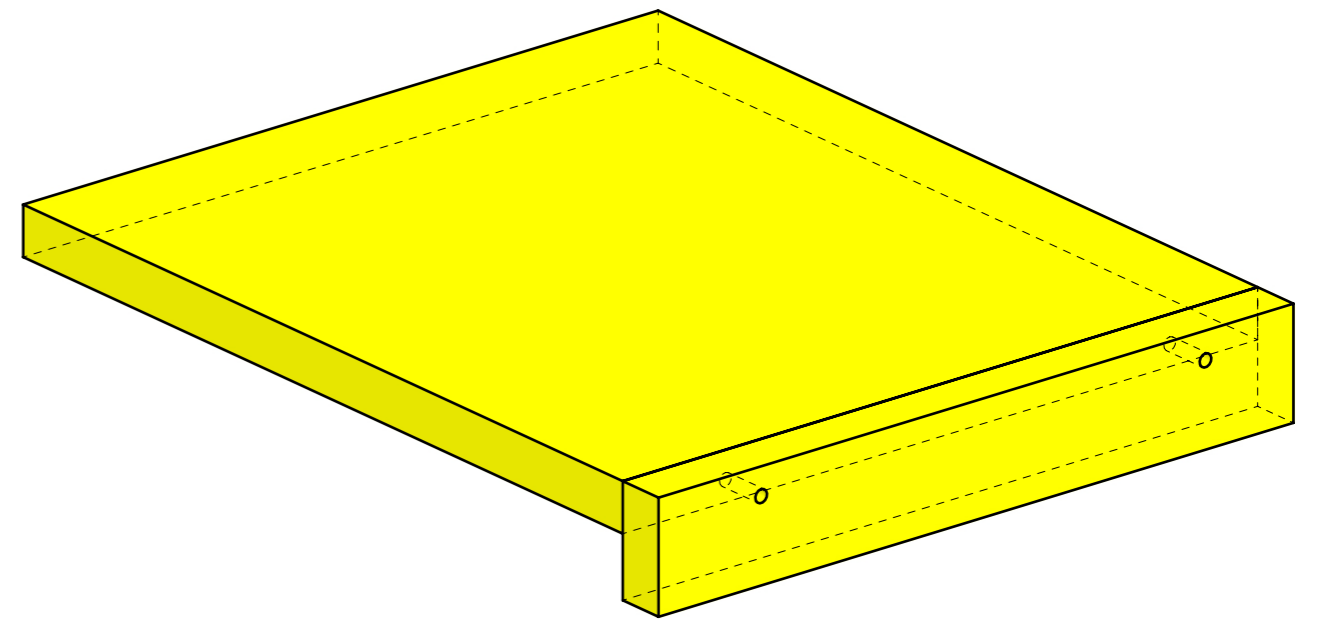
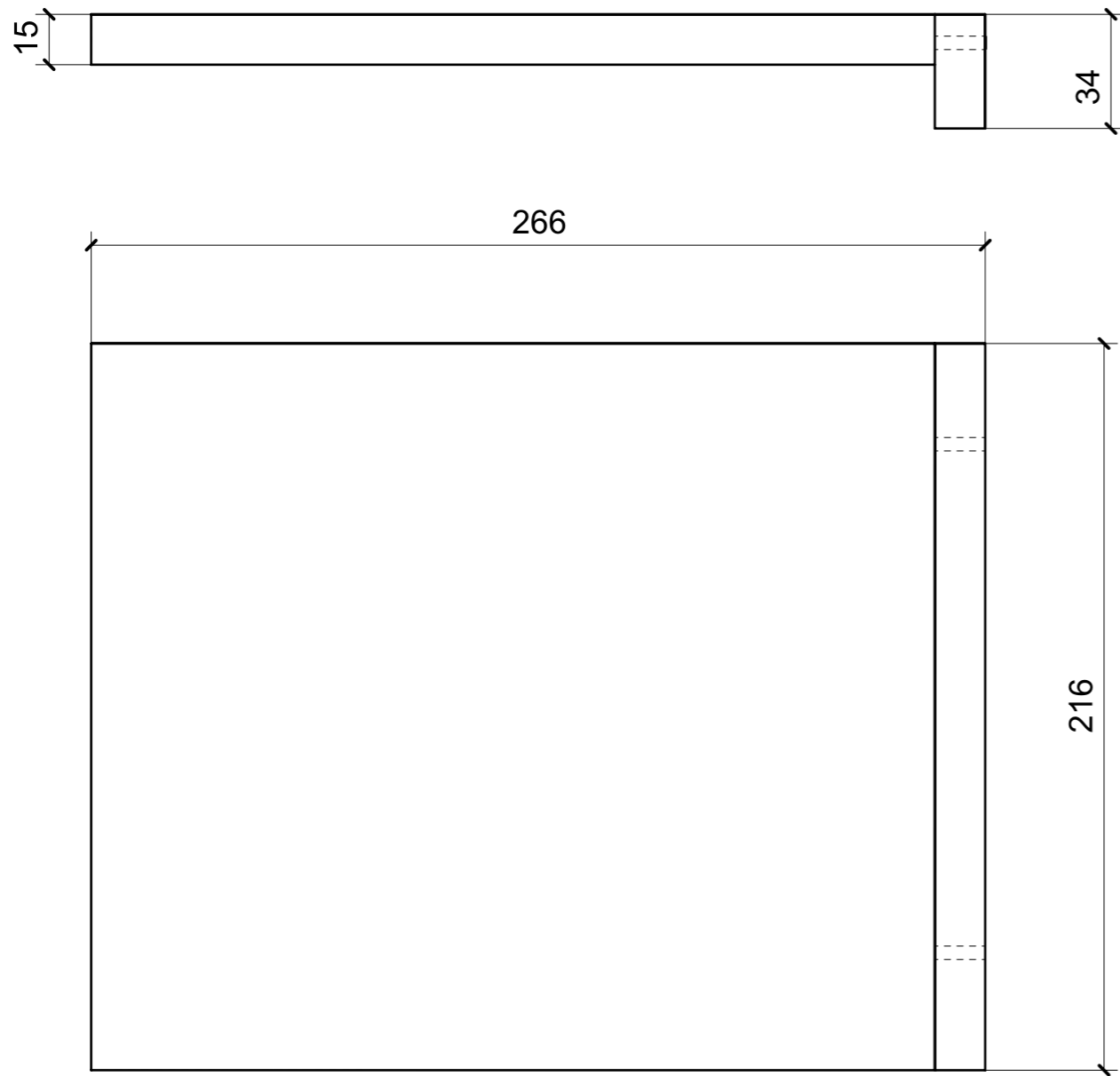

LOCALE	CODICE	DESCRIZIONE COMPONENTE	FINITURA	Q.TA
CABINA ARMATORE	MD299_I01_AS01	CIELINO	OKUME' GREZZO	1

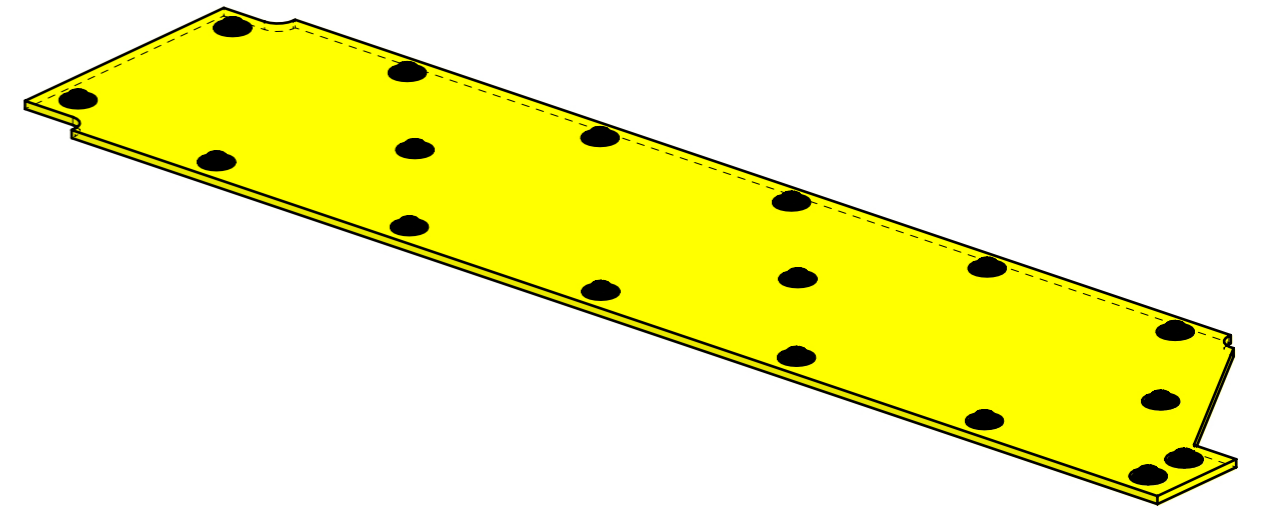
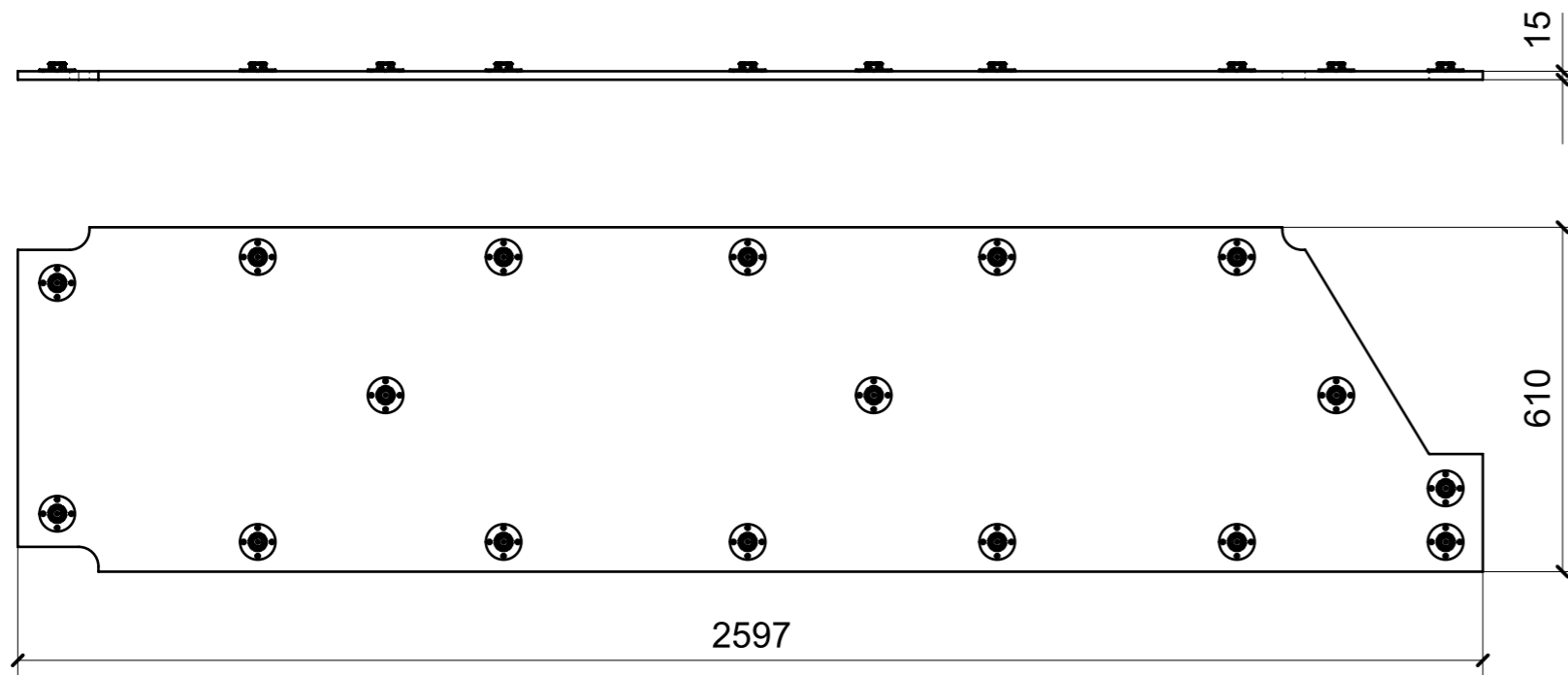

FERRAMENTA	QTY
FITLOCK M_MASCHERPA_3MM_6020202101	17

LOCALE	CODICE	DESCRIZIONE COMPONENTE	FINITURA	Q.TA
CABINA ARMATORE	MD299_I01_AY01	TESTALETTO_STD VAR 1	OKUME' GREZZO	1

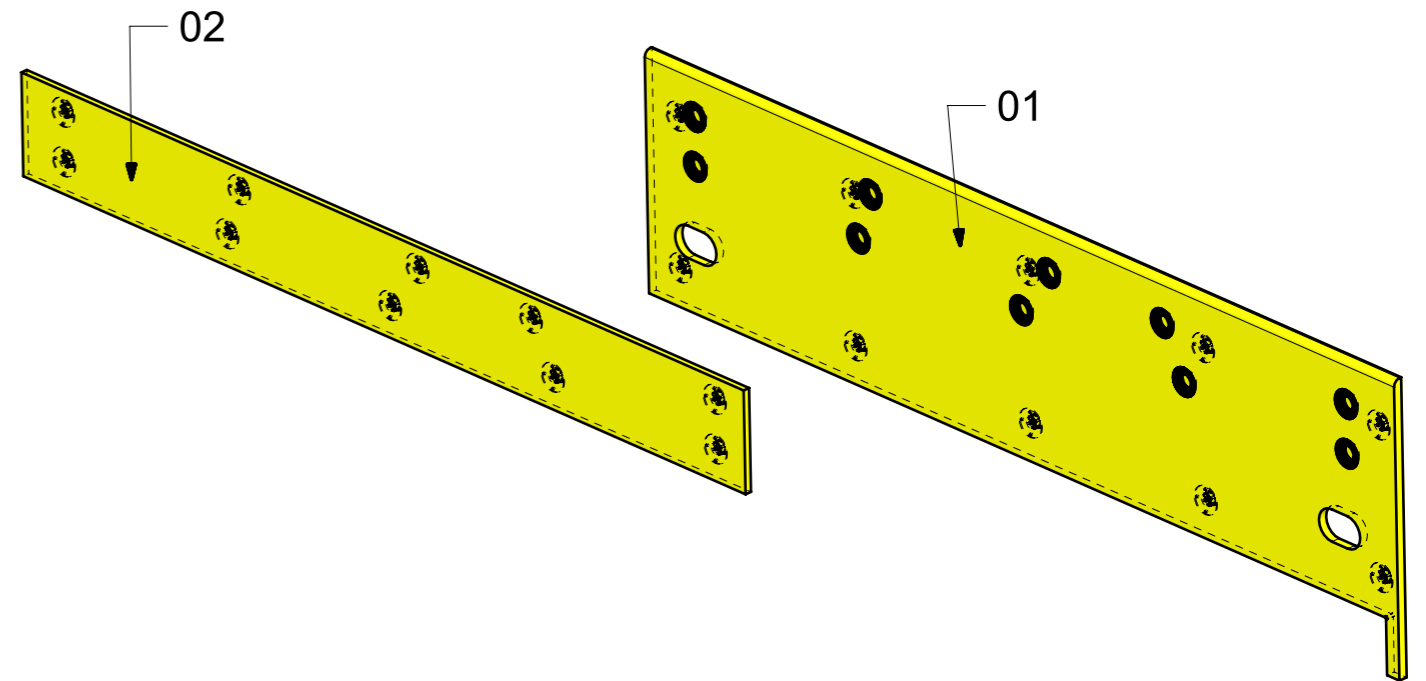
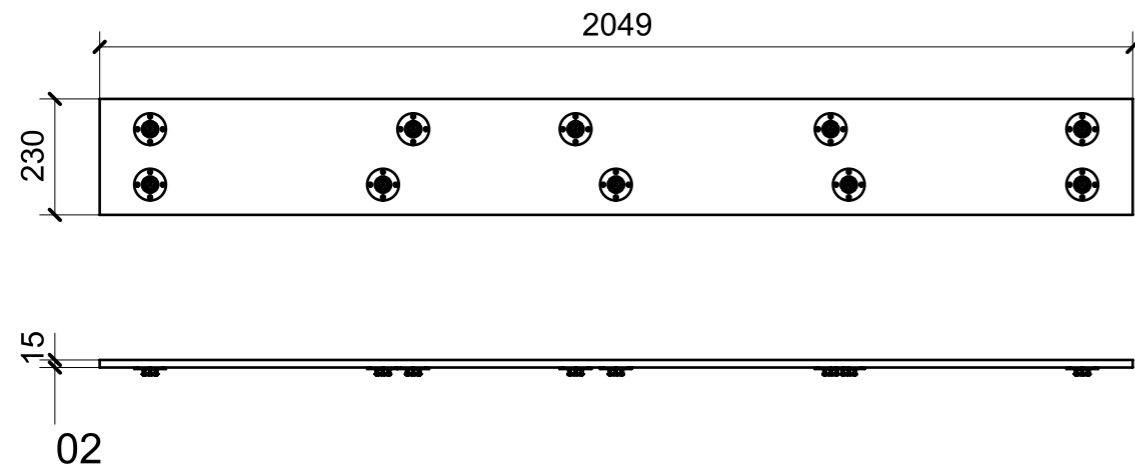
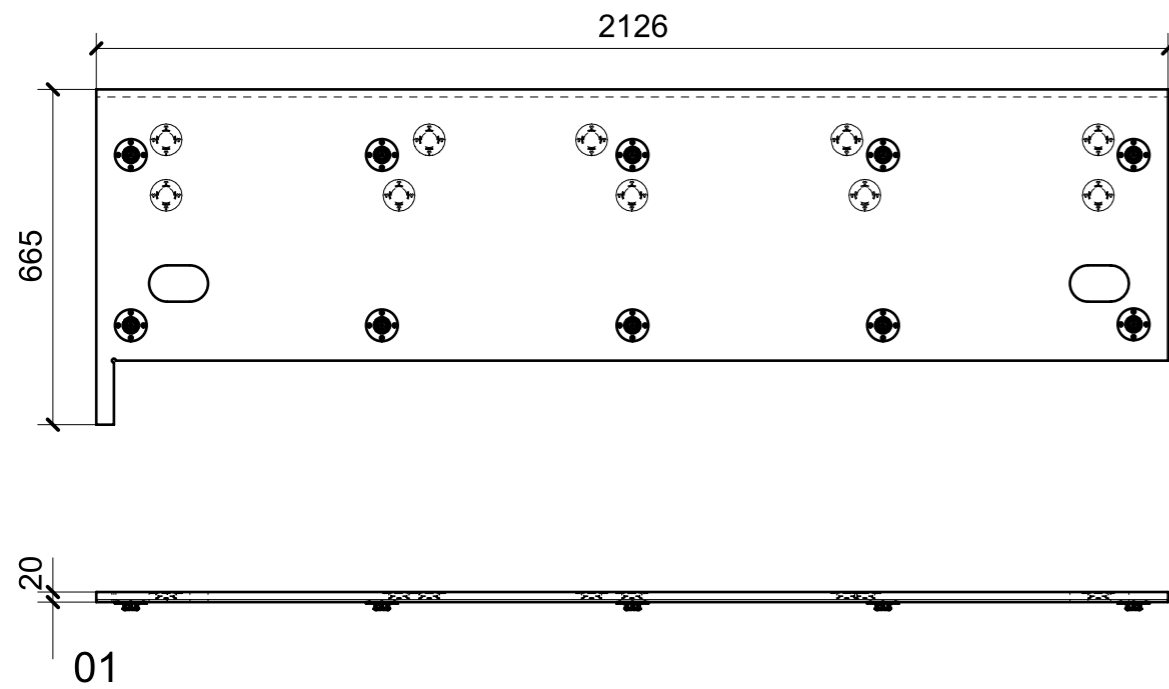

FERRAMENTA	QTY
FITLOCK F_MASCHERPA_6020101102	10
FITLOCK M_MASCHERPA_3MM_6020202101	20

LOCALE	CODICE	DESCRIZIONE COMPONENTE	FINITURA	Q.TA
CABINA ARMATORE	MD299_I01_AZ01	TESTALETTO_STD VAR 2	OKUME' GREZZO	1

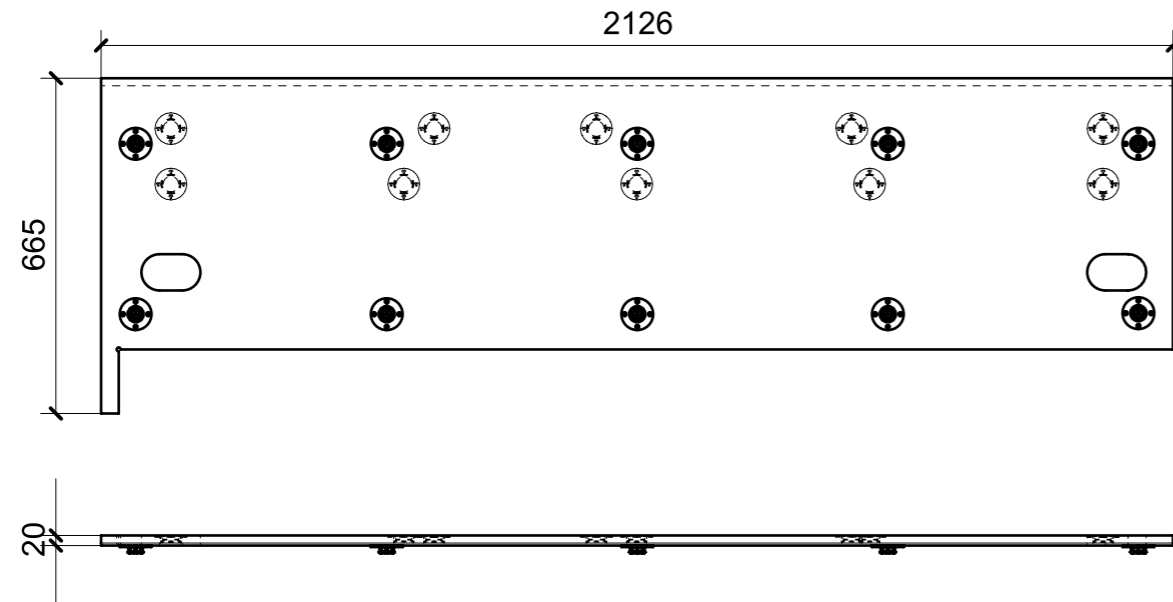

01

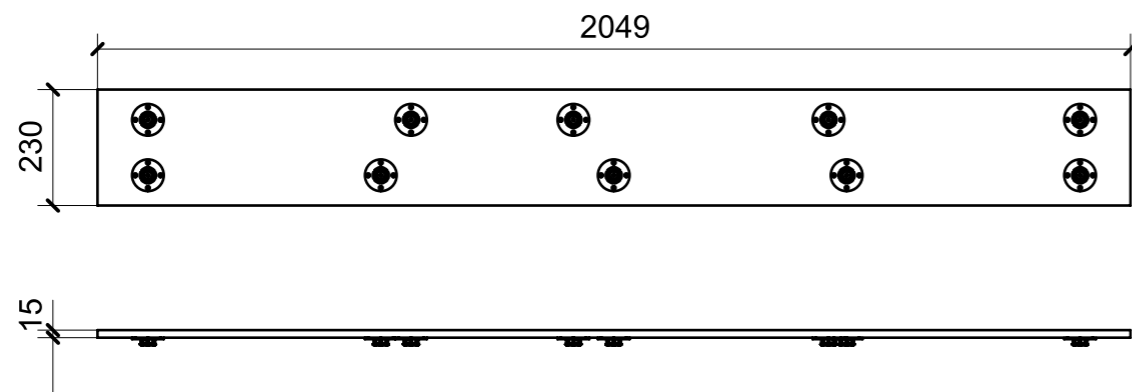

02

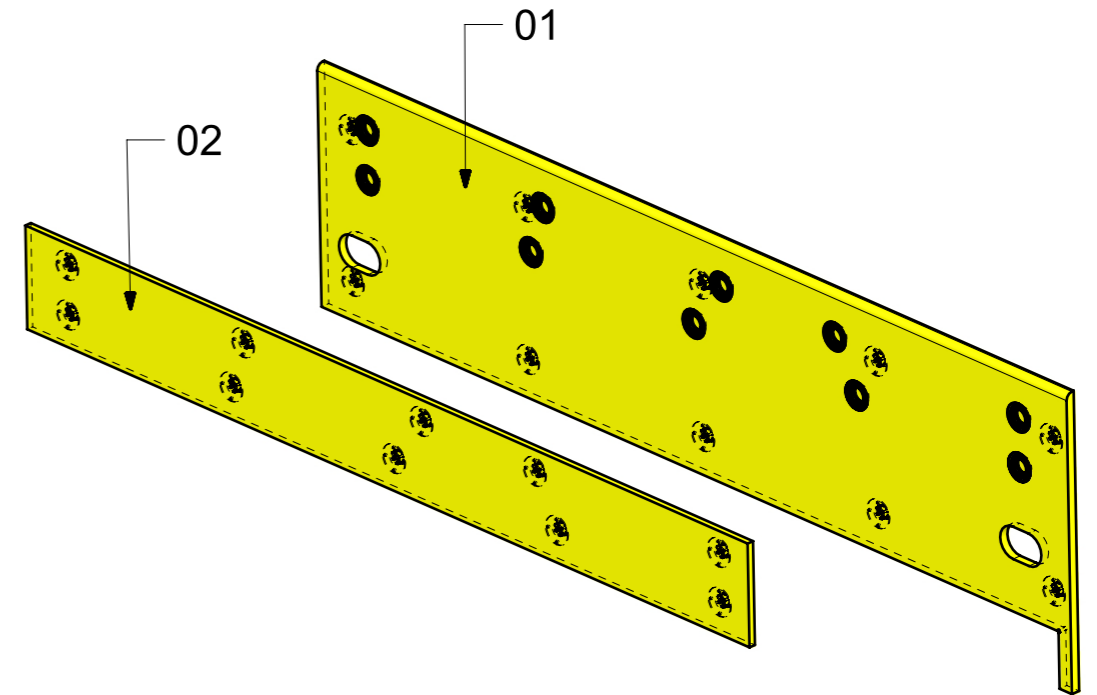

FERRAMENTA	QTY
FITLOCK F_MASCHERPA_6020101102	10
FITLOCK M_MASCHERPA_3MM_6020202101	20

LOCALE	CODICE	DESCRIZIONE COMPONENTE	FINITURA	Q.TA
CABINA ARMATORE	MD299_I01_AAQ01	COMODINO SX_STD VAR 2	OKUME' GREZZO	1

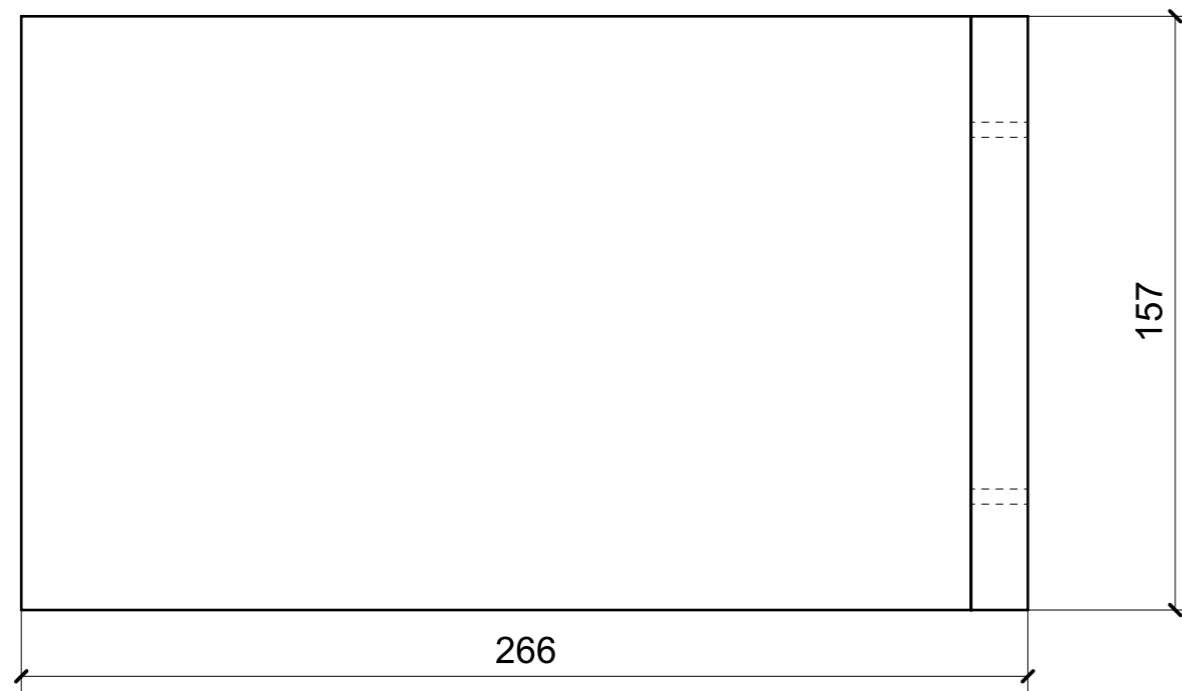
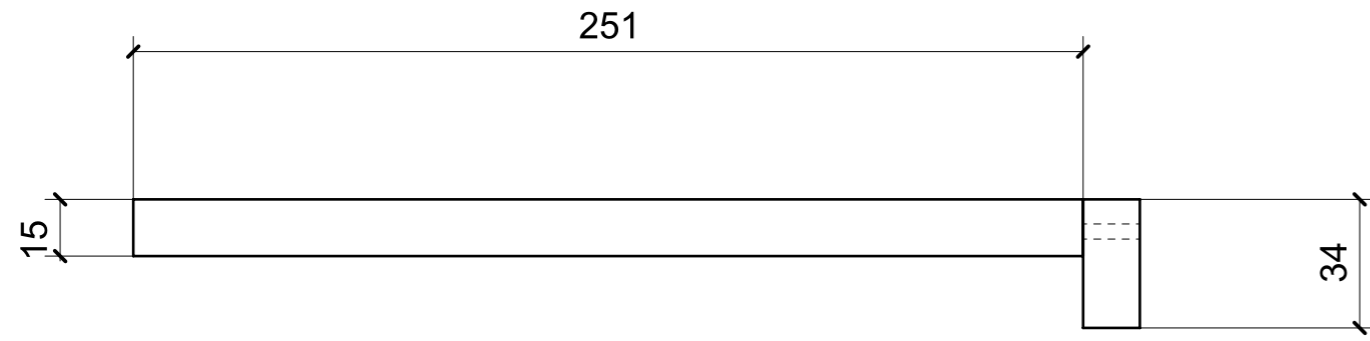

01

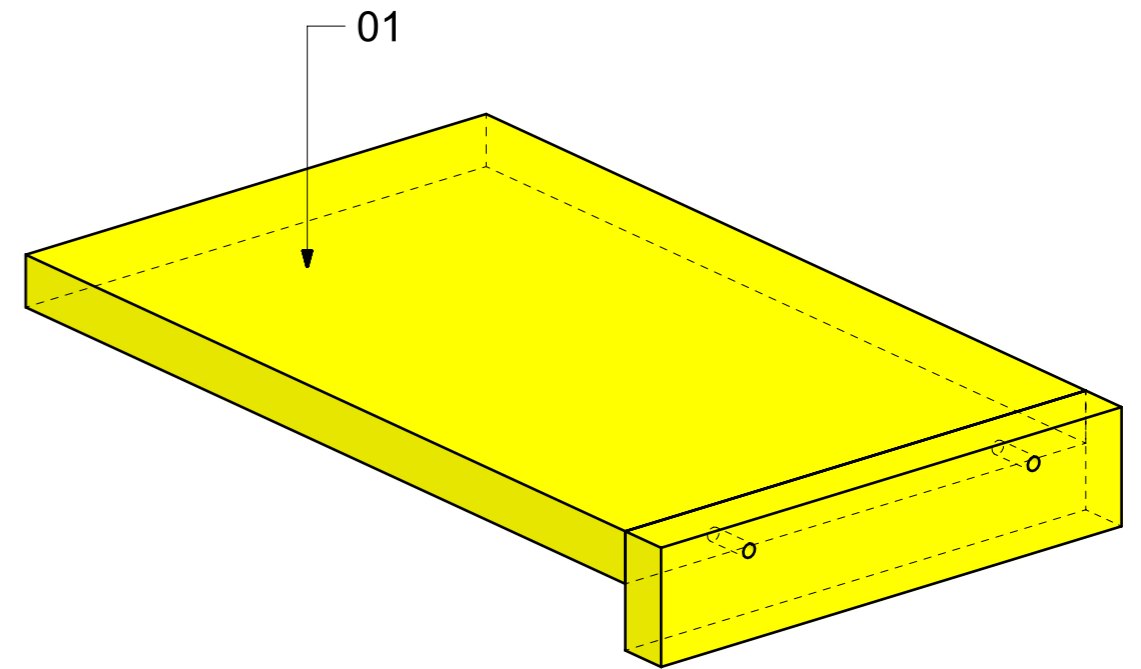

LOCALE	CODICE	DESCRIZIONE COMPONENTE	FINITURA	Q.TA
CABINA ARMATORE	MD299_I01_AAR01	COMODINO DX_STD VAR 2	OKUME' GREZZO	1

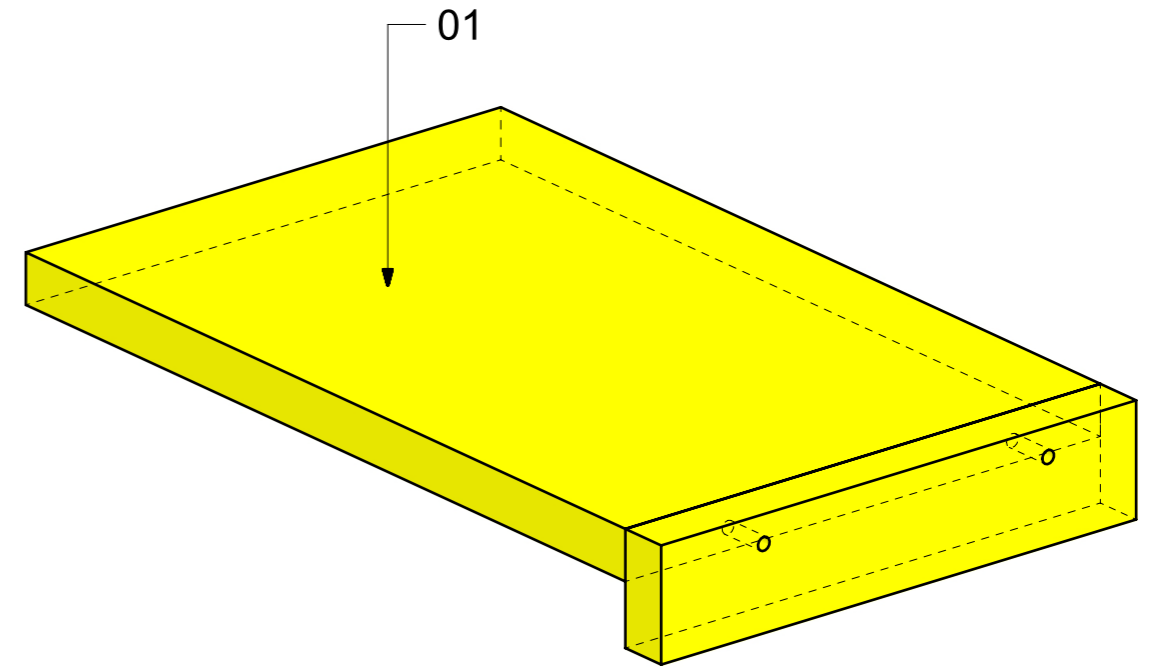
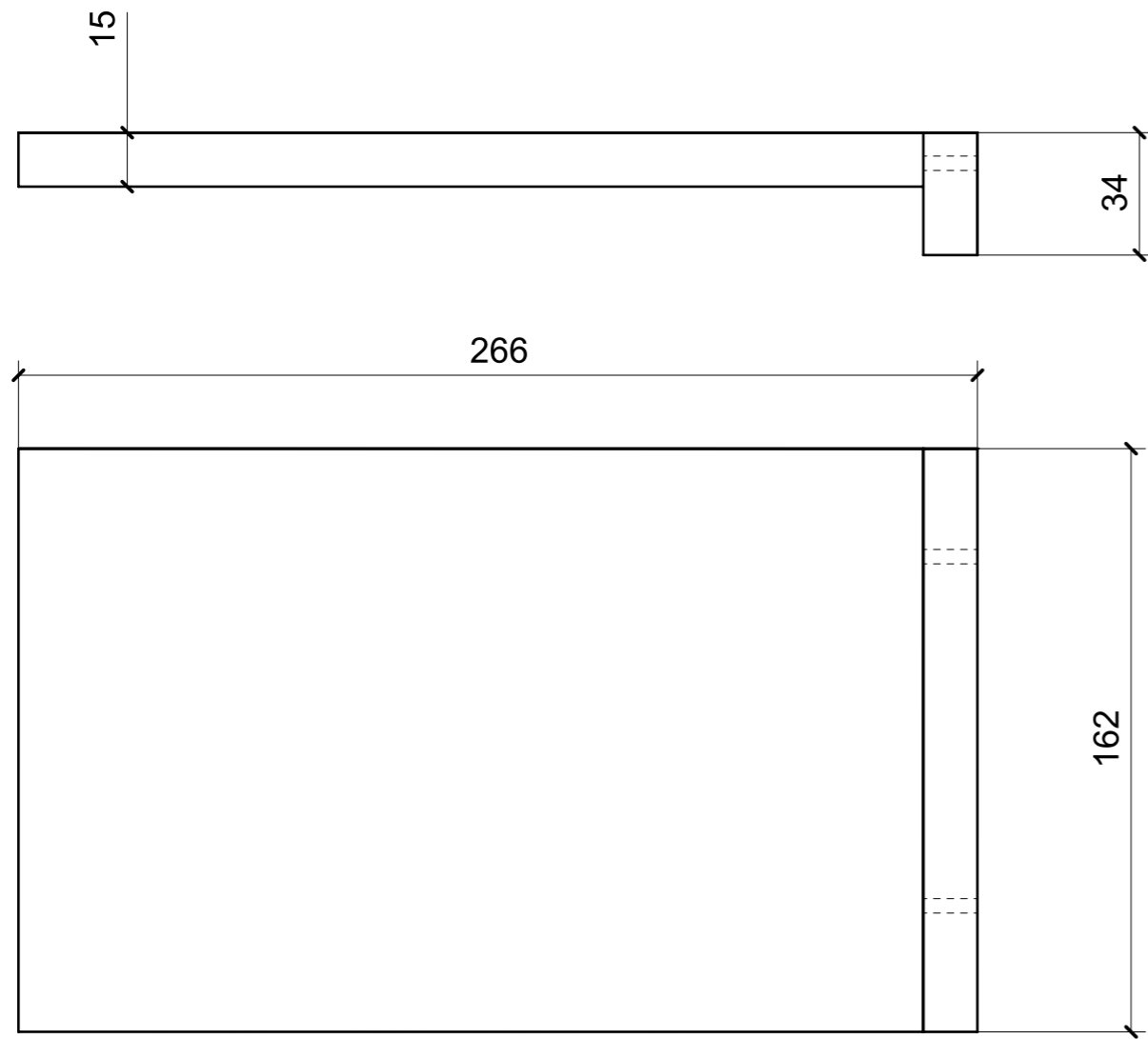

01

LOCALE	CODICE	DESCRIZIONE COMPONENTE	FINITURA	Q.TA
BAGNO ARMATORE	MD299_I01_WQ01	PANNELLO OBLO'	OKUME' GREZZO	1

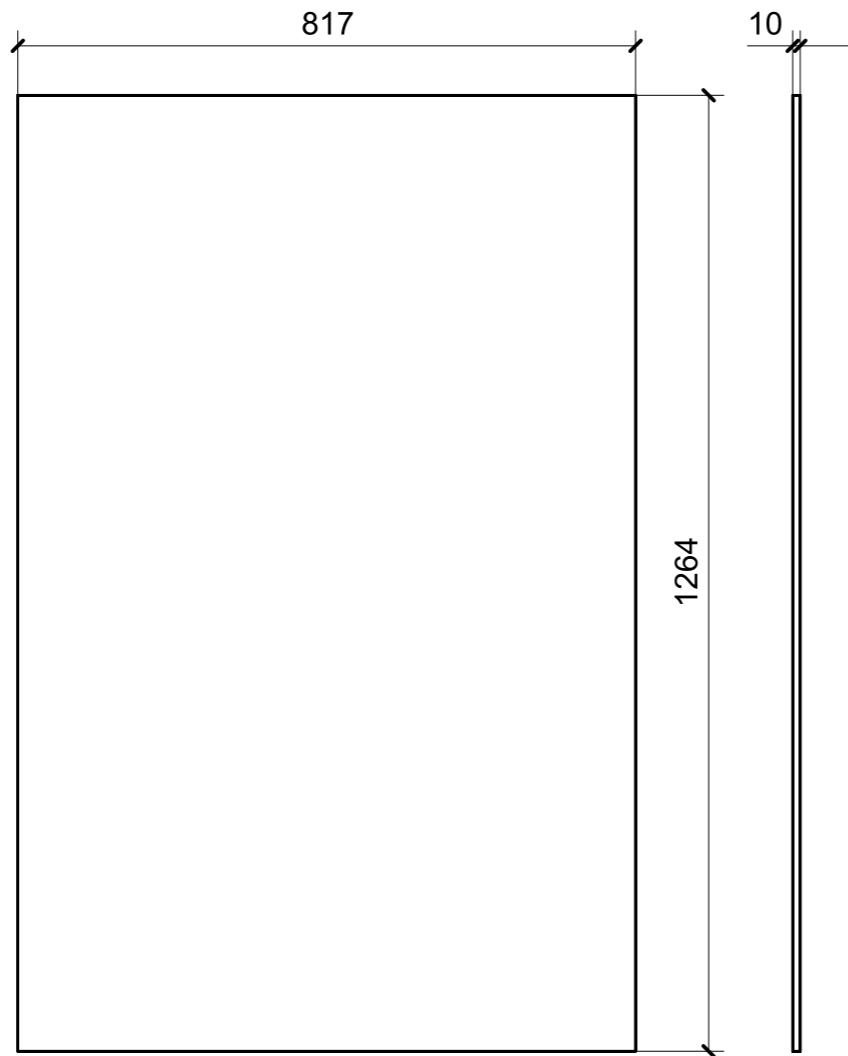

01

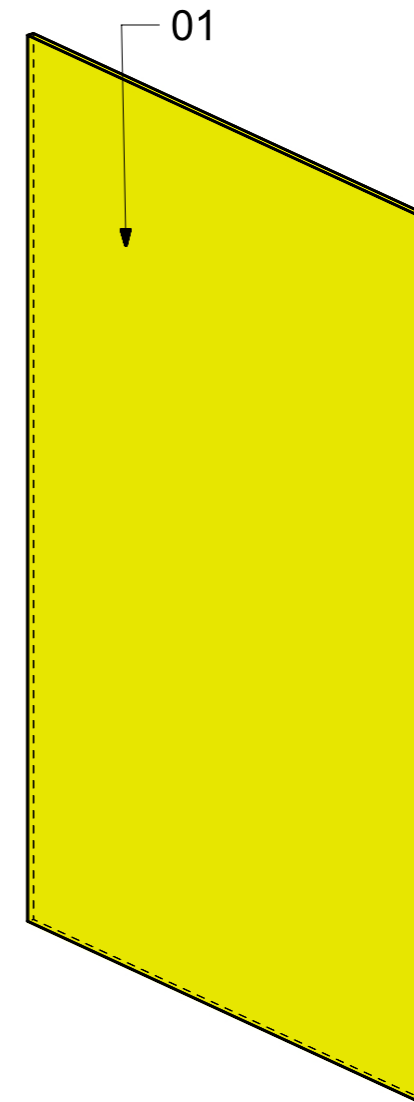

LOCALE	CODICE	DESCRIZIONE COMPONENTE	FINITURA	Q.TA
CABINA VIP	MD299_I01_VA01	LETTO	OKUME' GREZZO	3

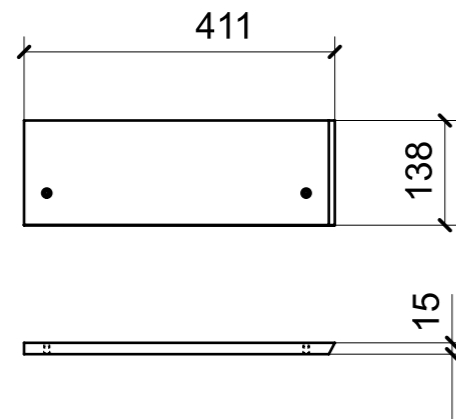

01

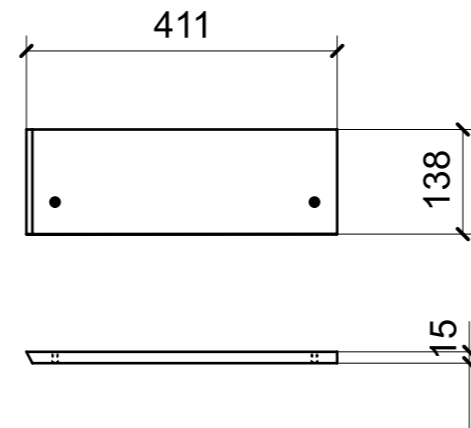

03

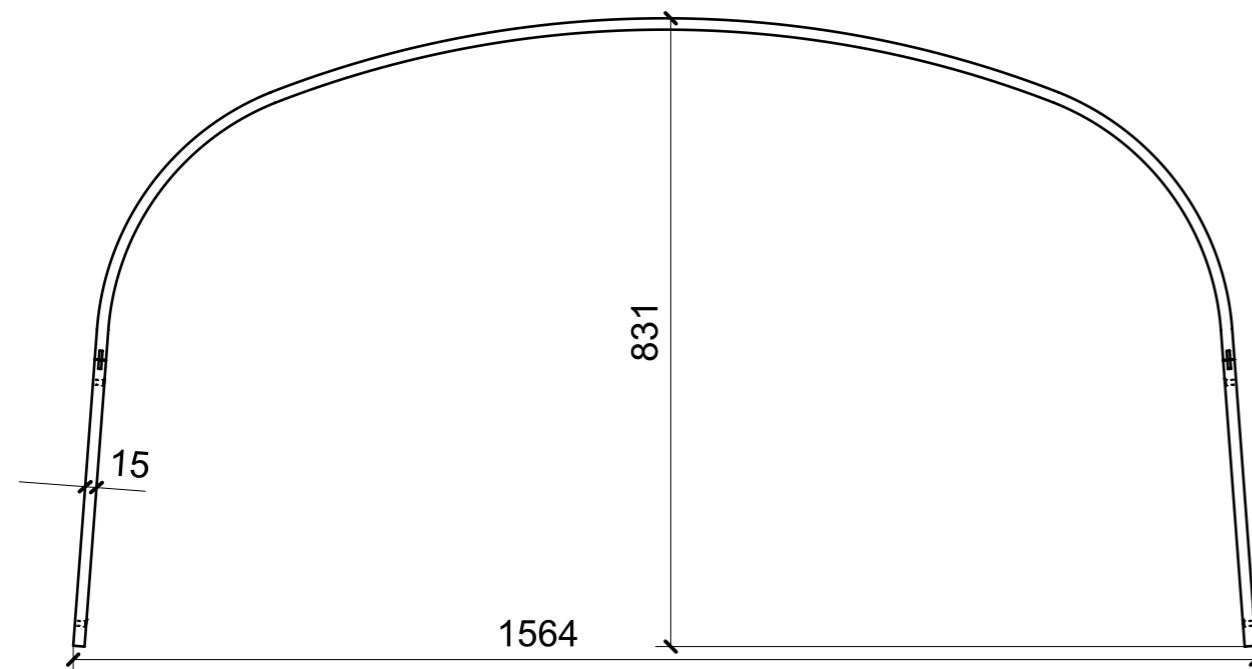
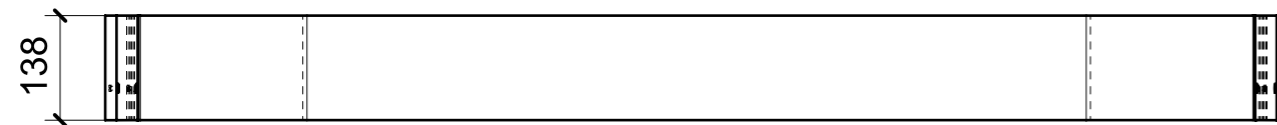
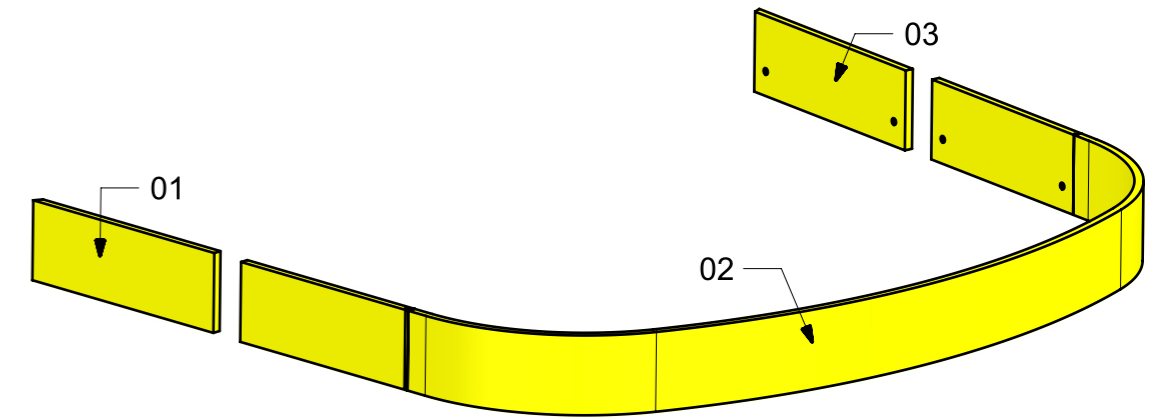

02

FERRAMENTA	QTY
BUSSOLA 5MA X 10 FORO DIAM.8	8

LOCALE	CODICE	DESCRIZIONE COMPONENTE	FINITURA	Q.TA
CABINA VIP	MD299_I01_VB01	COMODINI	OKUME' GREZZO	1

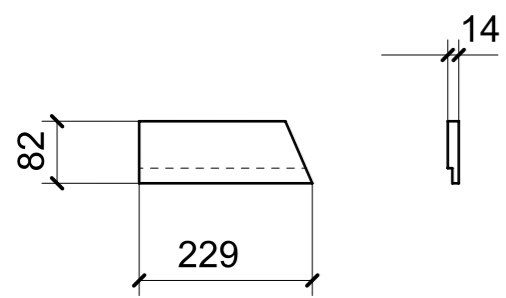

01

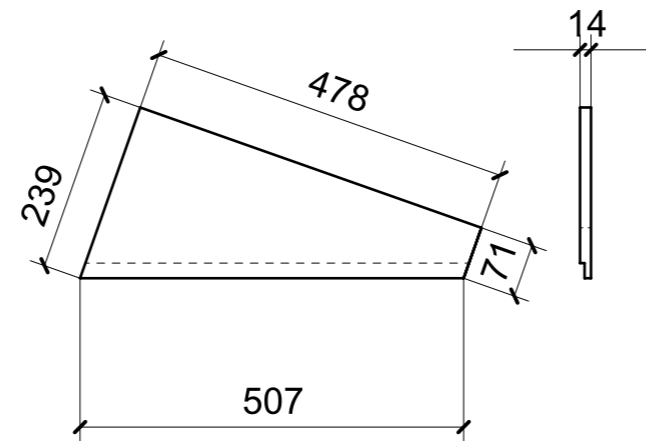

02

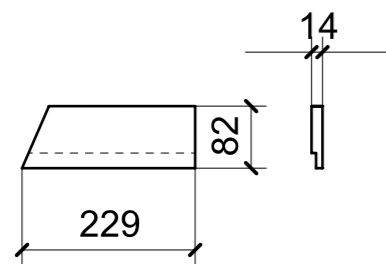
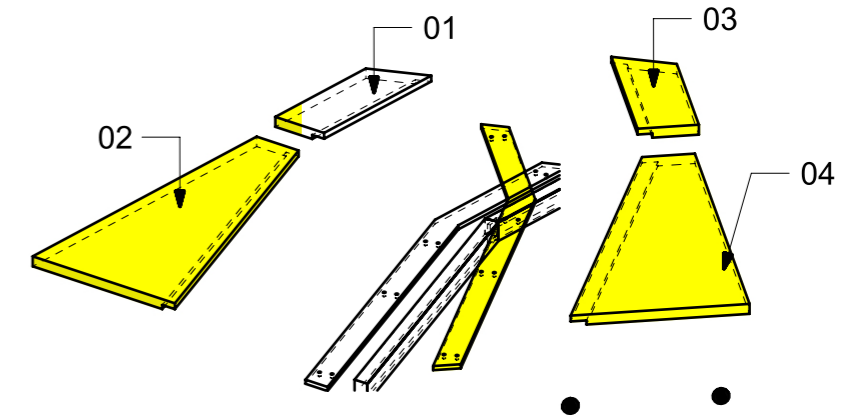

03

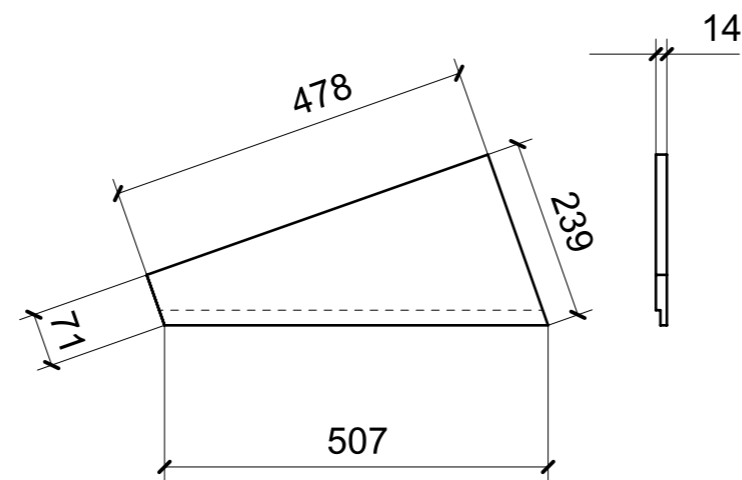

04

LOCALE	CODICE	DESCRIZIONE COMPONENTE	FINITURA	Q.TA
CABINA VIP	MD299_I01_VC01	COLLEGAMENTO MURA DX	OKUME' GREZZO	1

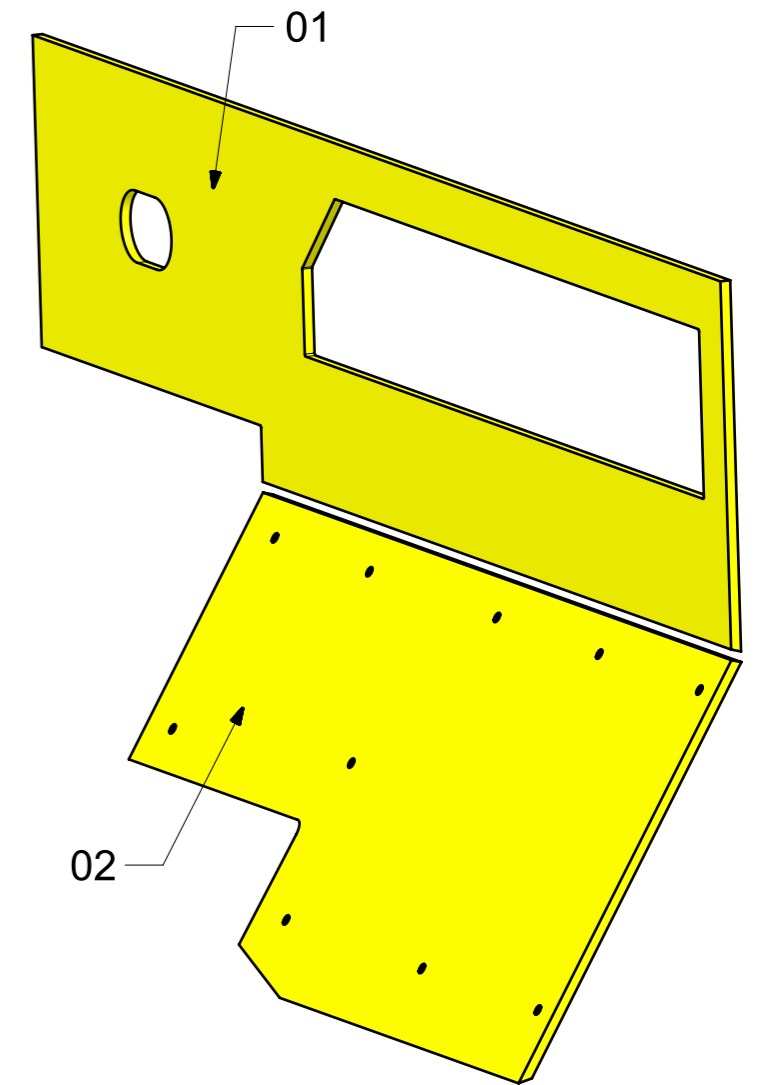
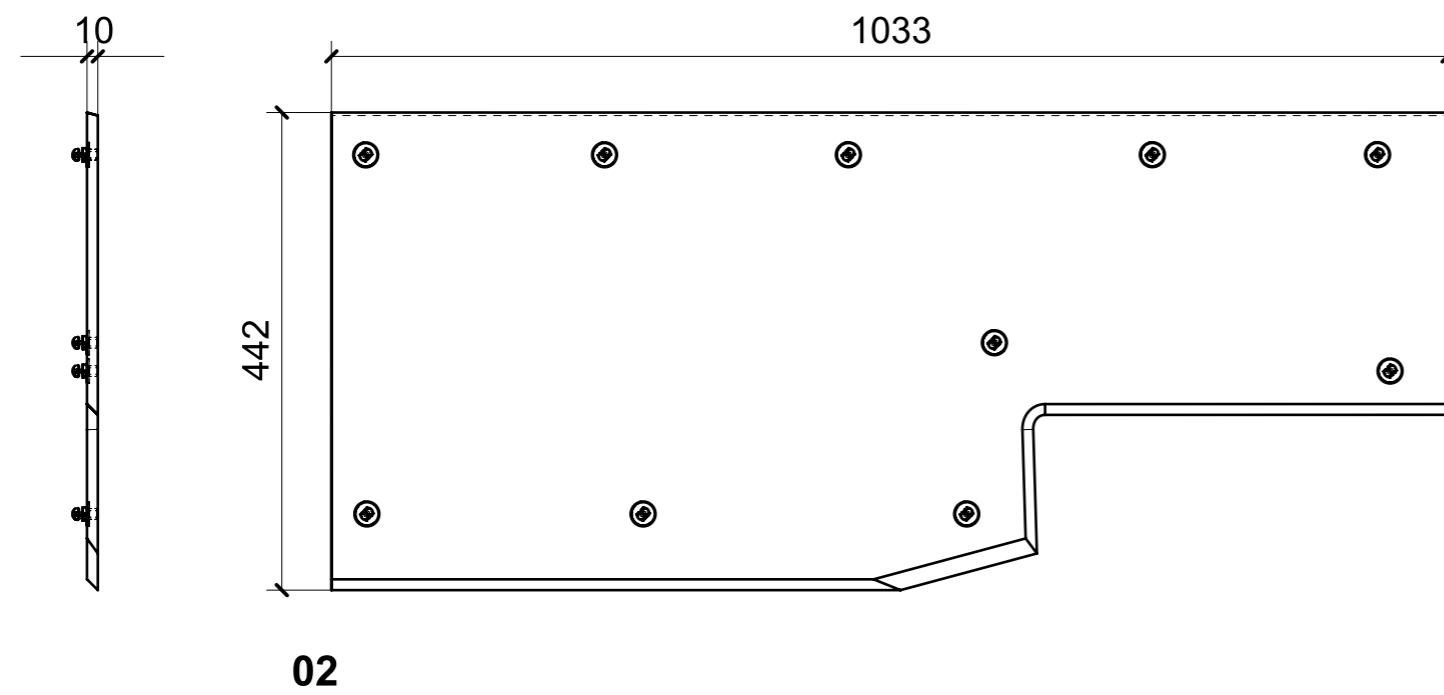
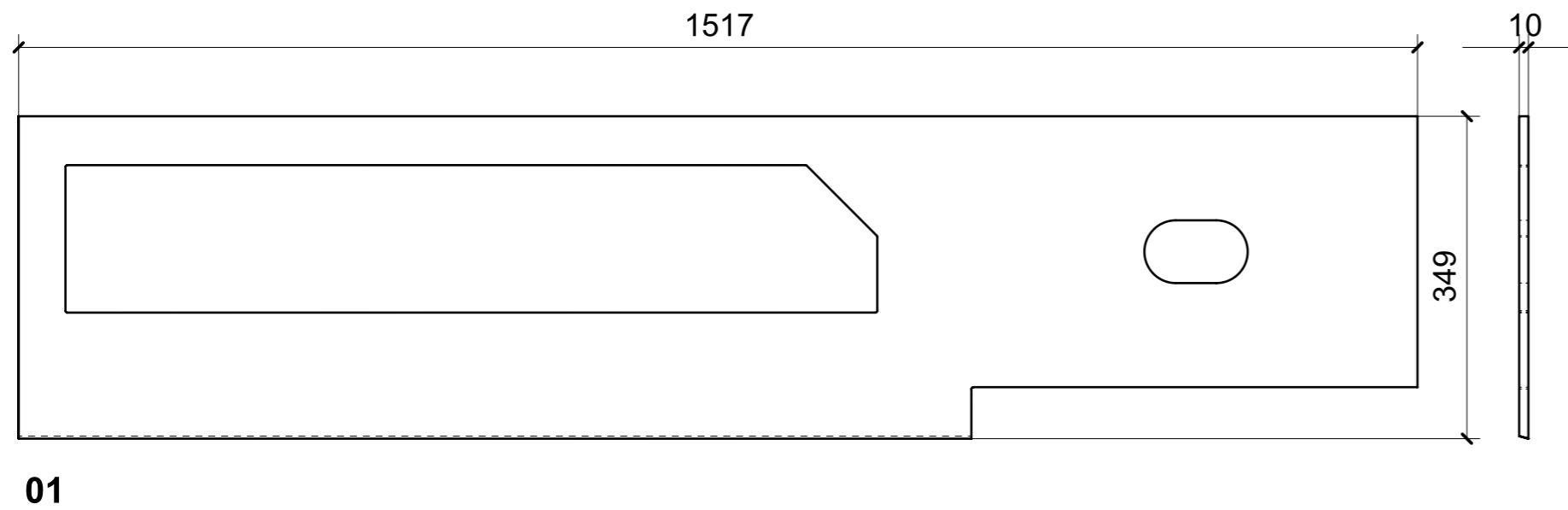

FERRAMENTA	QTY
MS INCASSO_ITALVIPLA_972_FMPC_M1B	10

LOCALE	CODICE	DESCRIZIONE COMPONENTE	FINITURA	Q.TA
CABINA VIP	MD299_I01_VD01	COLLEGAMENTO MURA SX	OKUME' GREZZO	1

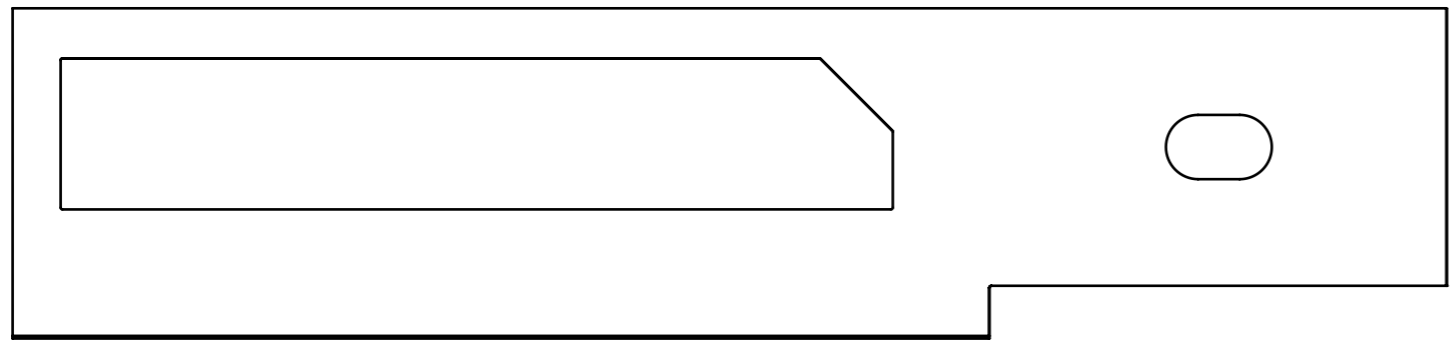

01

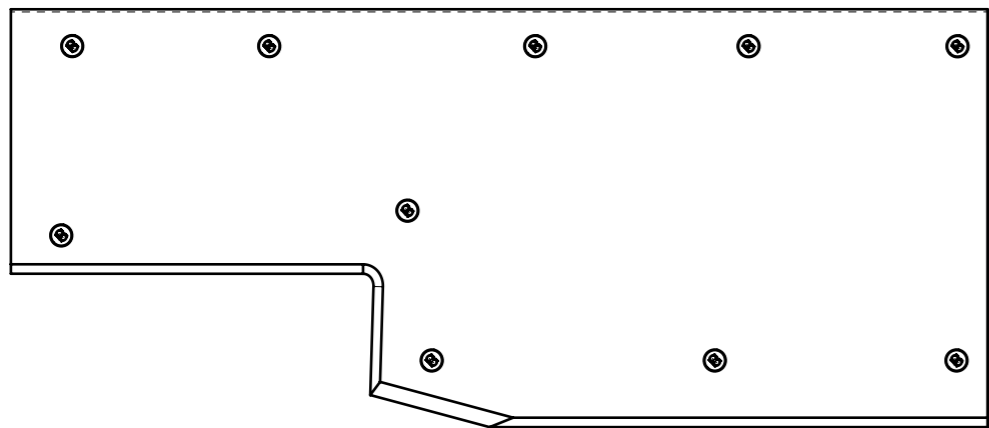

02

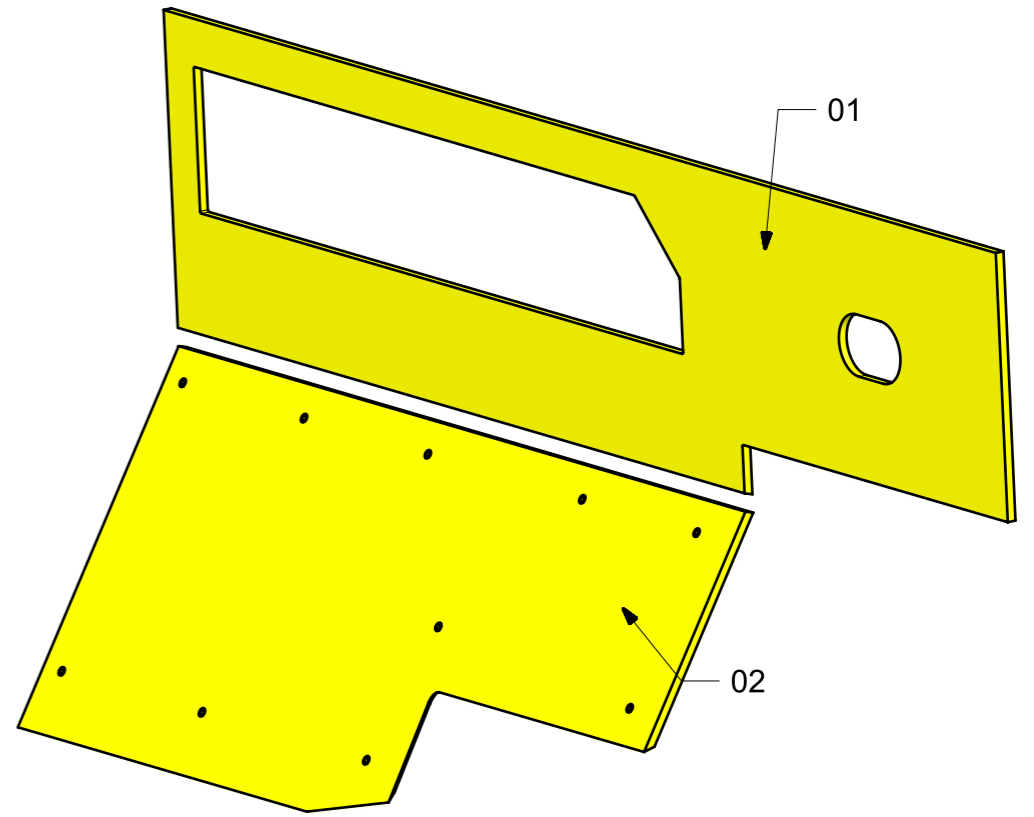

FERRAMENTA	QTY
MS INCASSO_ITALVIPLA_972_FMPC_M1B	10

LOCALE	CODICE	DESCRIZIONE COMPONENTE	FINITURA	Q.TA
CABINA VIP	MD299_I01_VG01	ARMADIO SX	OKUME' GREZZO	1

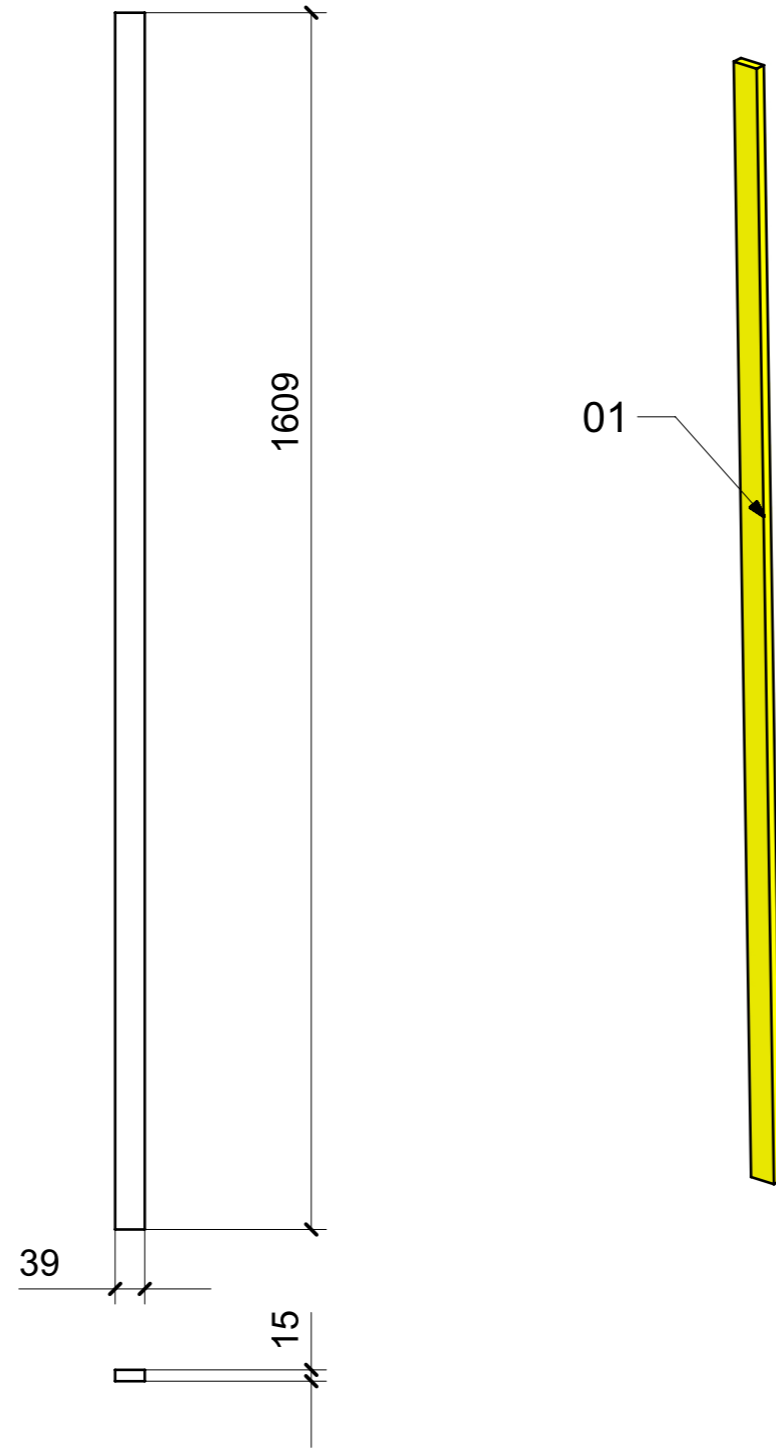

LOCALE	CODICE	DESCRIZIONE COMPONENTE	FINITURA	Q.TA
CABINA VIP	MD299_I01_VI01	PENSILE SX	OKUME' GREZZO	1

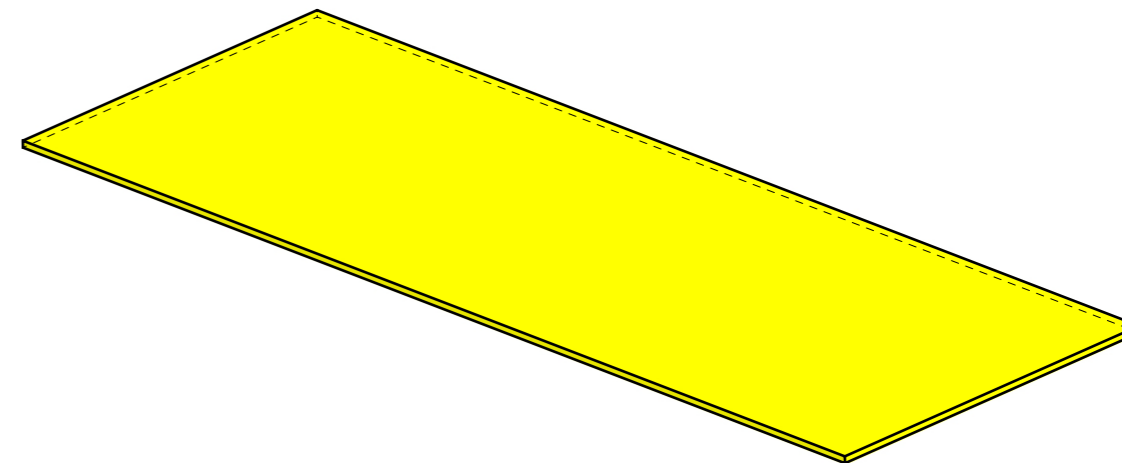
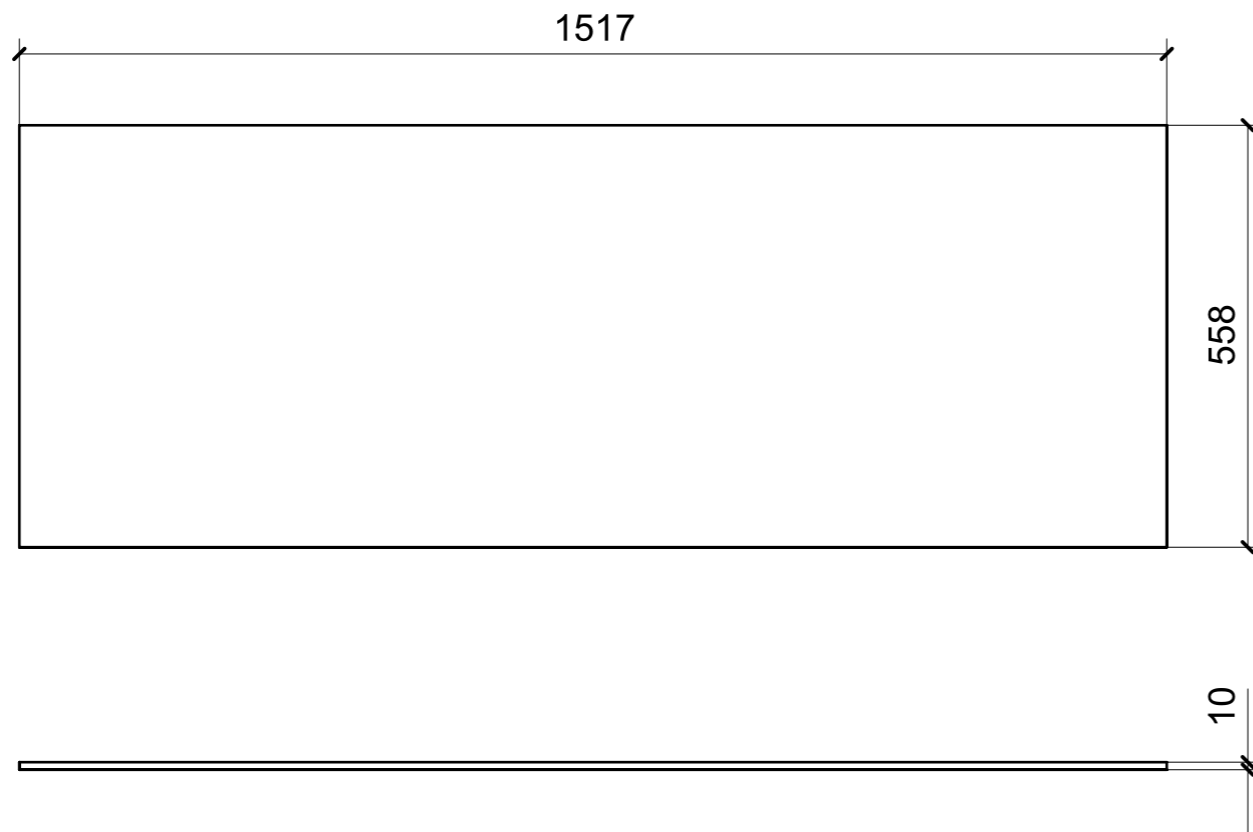

VERNICIATURA LASTRA:  
● = VERNICIARE 1 LATO + FILI RASATI O BORDATI      NESSUN SIMBOLO = VERNICIARE 2 LATI + FILI RASATI O BORDATI

LOCALE	CODICE	DESCRIZIONE COMPONENTE	FINITURA	Q.TA
CABINA VIP	MD299_I01_VL01	PENSILE DX	OKUME' GREZZO	1

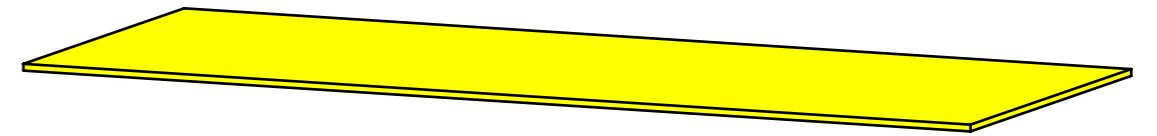
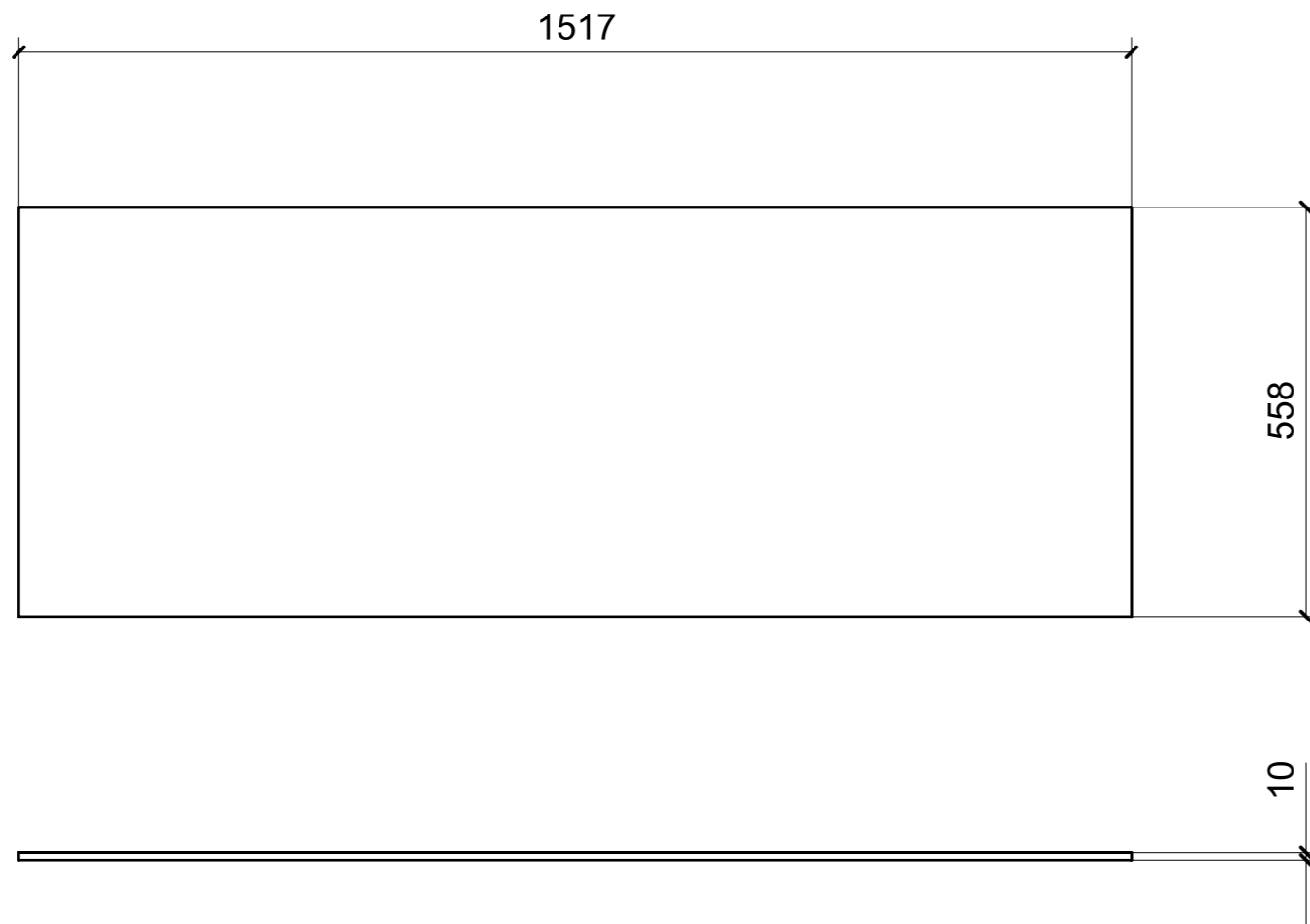

LOCALE	CODICE	DESCRIZIONE COMPONENTE	FINITURA	Q.TA
CABINA VIP	MD299_I01_VM01	RIV. MURATA SX POPPA	OKUME' GREZZO	1

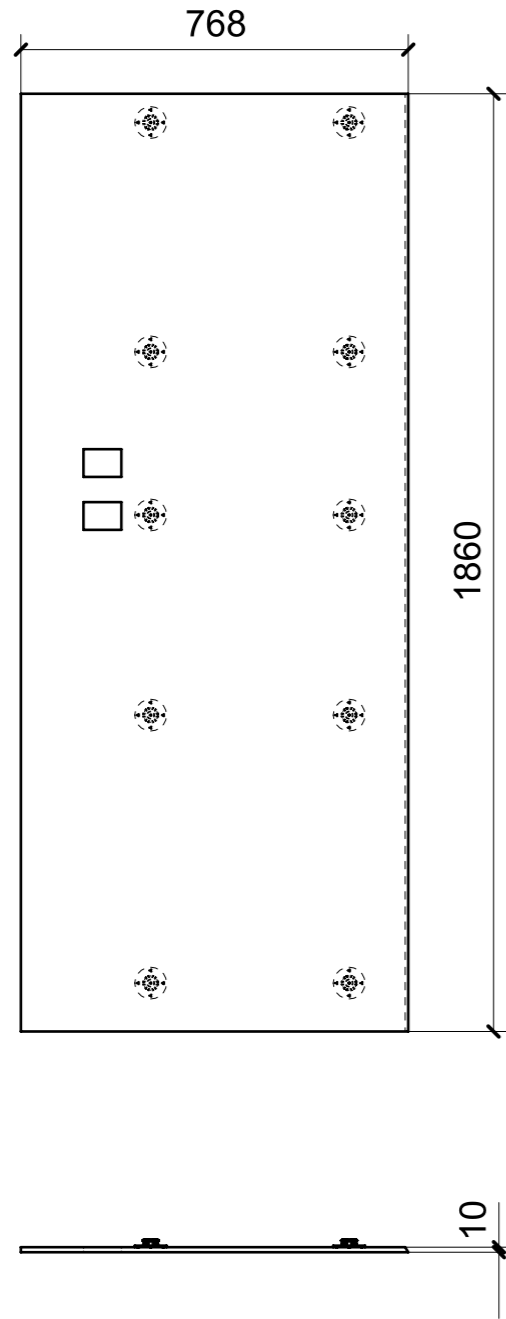

01

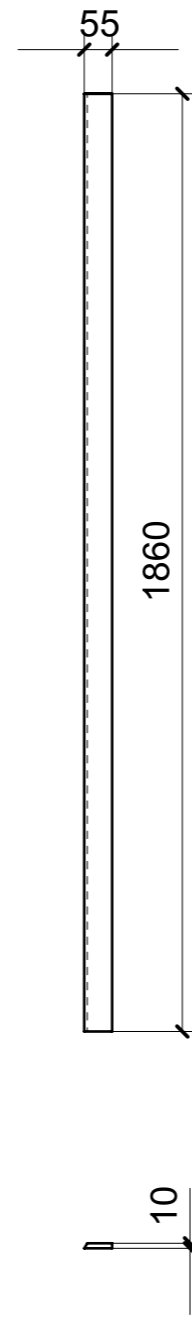

02

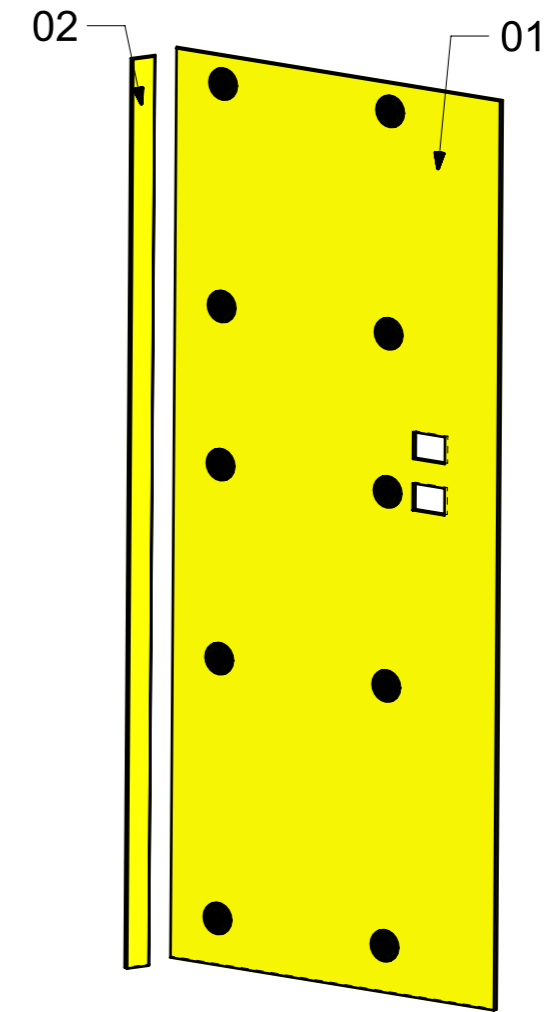

FERRAMENTA	QTY
FITLOCK M_MASCHERPA_3MM_6020202101	10

LOCALE	CODICE	DESCRIZIONE COMPONENTE	FINITURA	Q.TA
CABINA VIP	MD299_I01_VO01	RIVESTIMENTO _STD VAR1 SENZA TV	OKUME' GREZZO	1

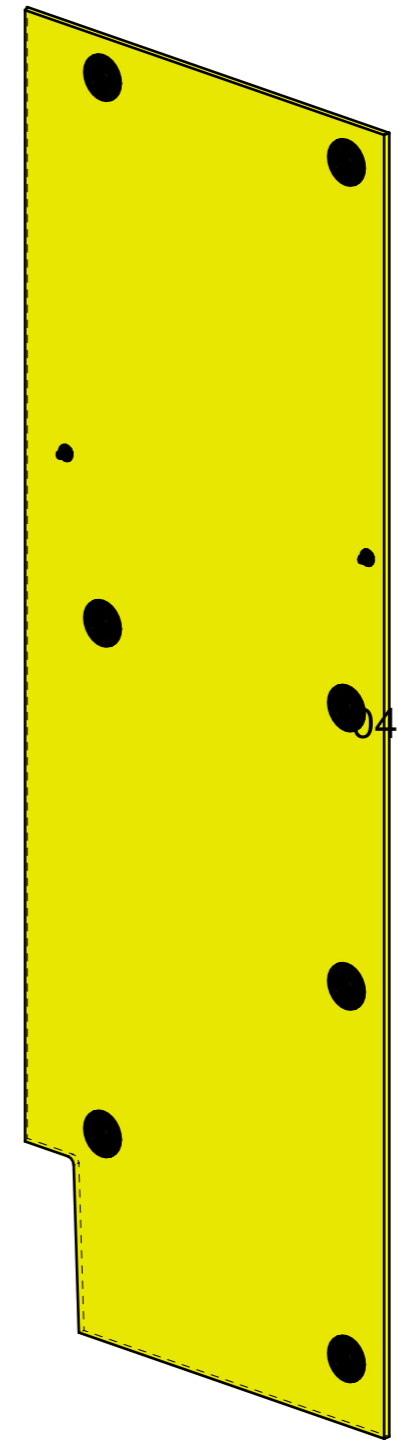
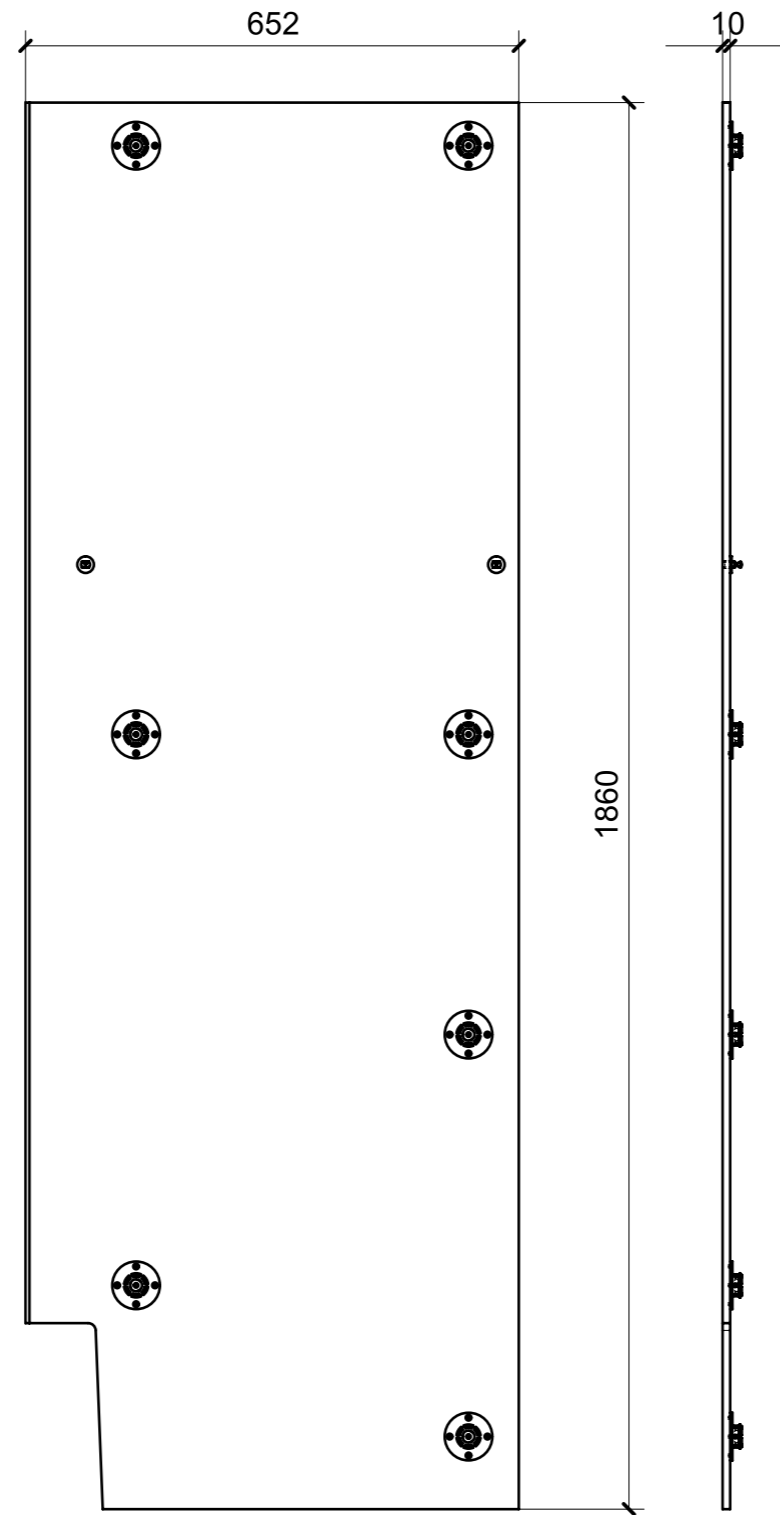

FERRAMENTA	QTY
FITLOCK M_MASCHERPA_3MM_6020202101	7
MS INCASSO_ITALVIPLA_972_FMPC_M1B	2

LOCALE	CODICE	DESCRIZIONE COMPONENTE	FINITURA	Q.TA
CABINA VIP	MD299_I01_VP01	RIVESTIMENTO STD VAR 2 CON TV	OKUME' GREZZO	1

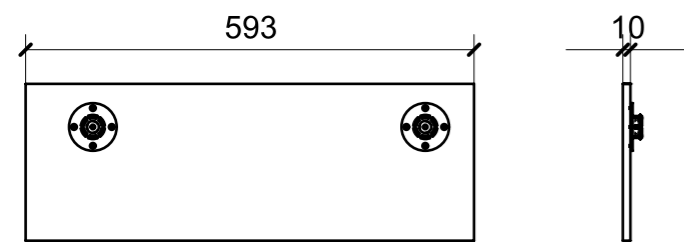

01

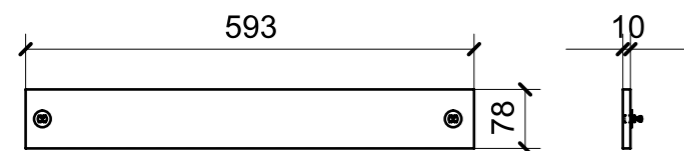

02

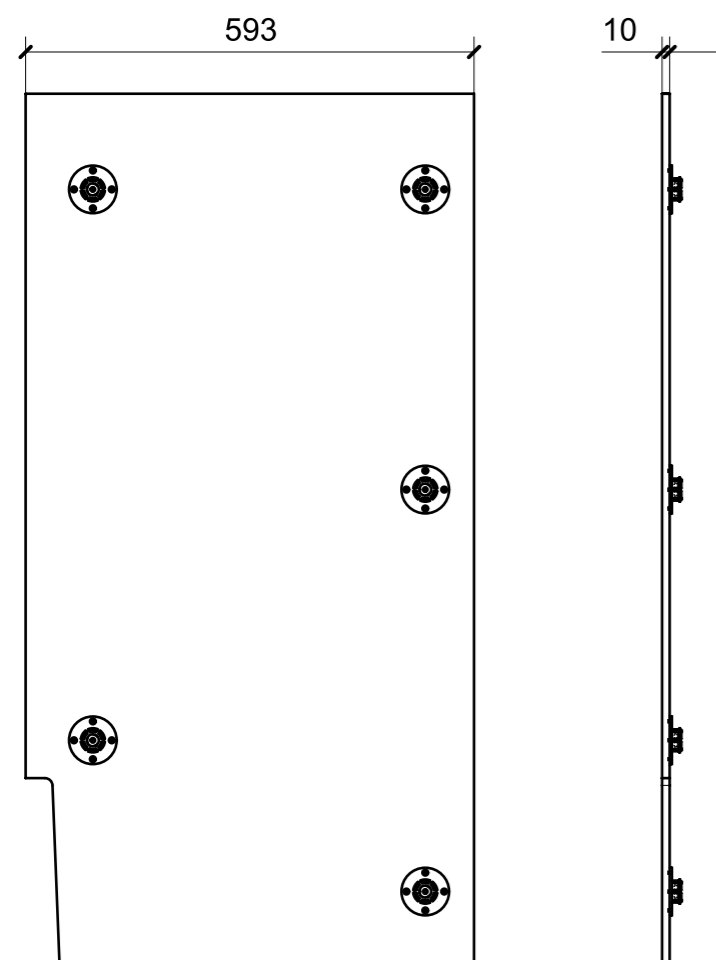

03

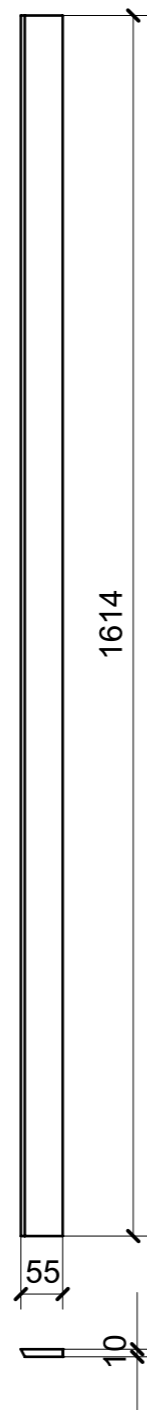

04

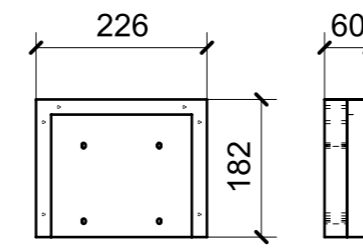

05

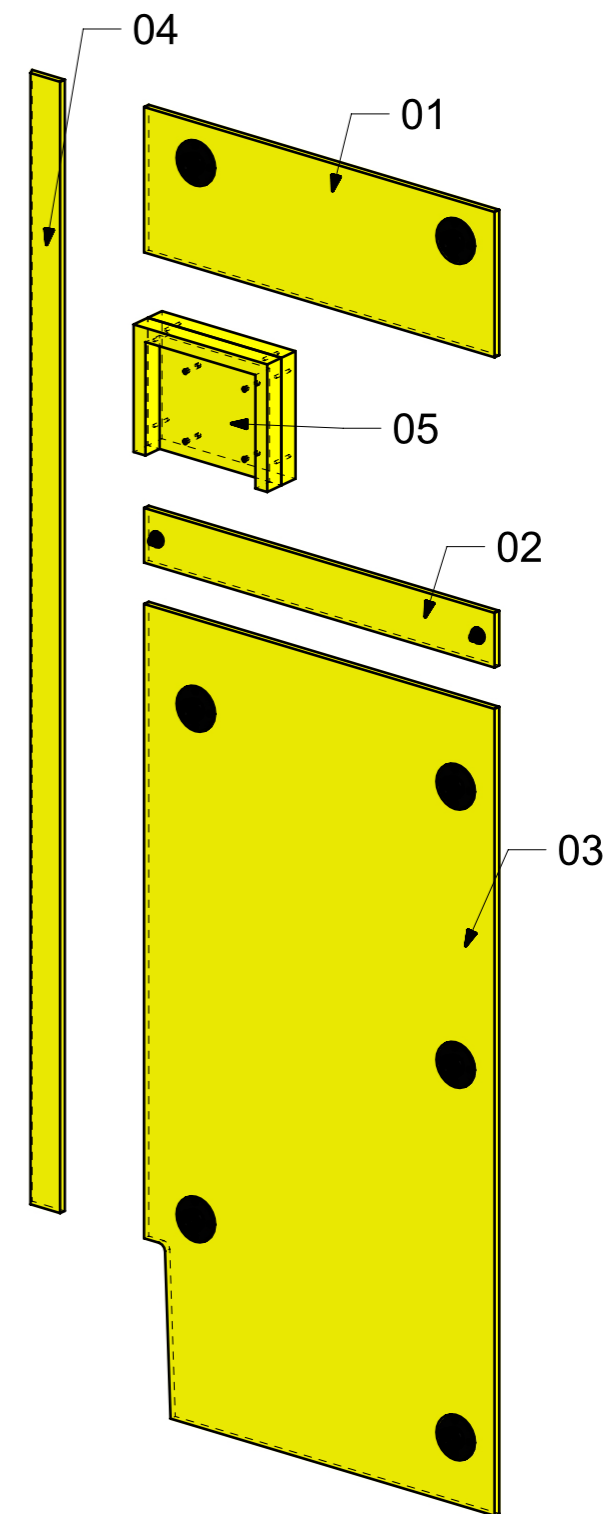

FERRAMENTA	QTY
MS INCASSO_ITALVIPLA_972_FMPC_M1B	2
FITLOCK M_MASCHERPA_3MM_6020202101	7

LOCALE	CODICE	DESCRIZIONE COMPONENTE	FINITURA	Q.TA
CABINA VIP	MD299_I01_VQ01	CIELINO	OKUME' GREZZO	1

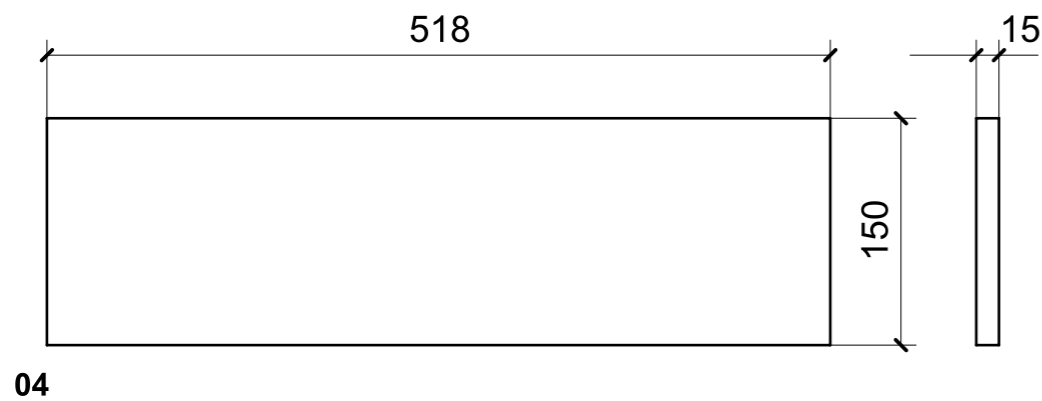
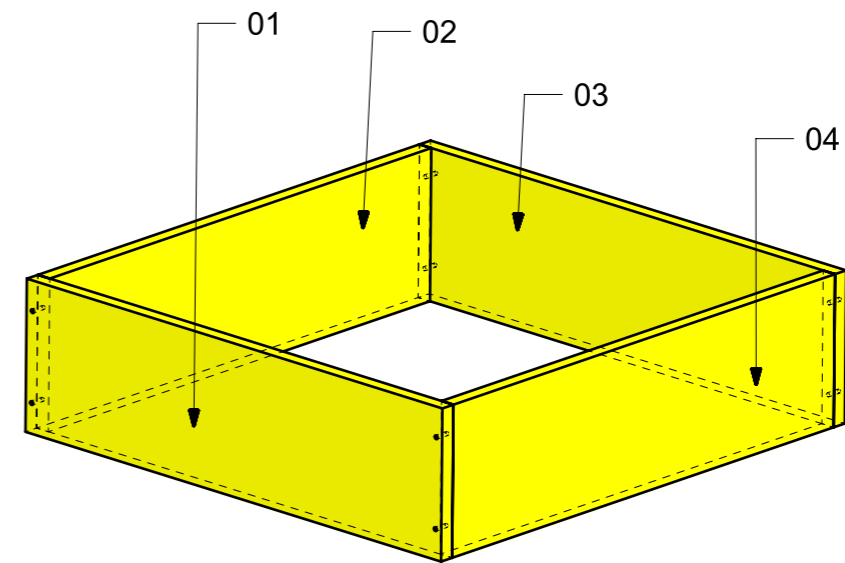
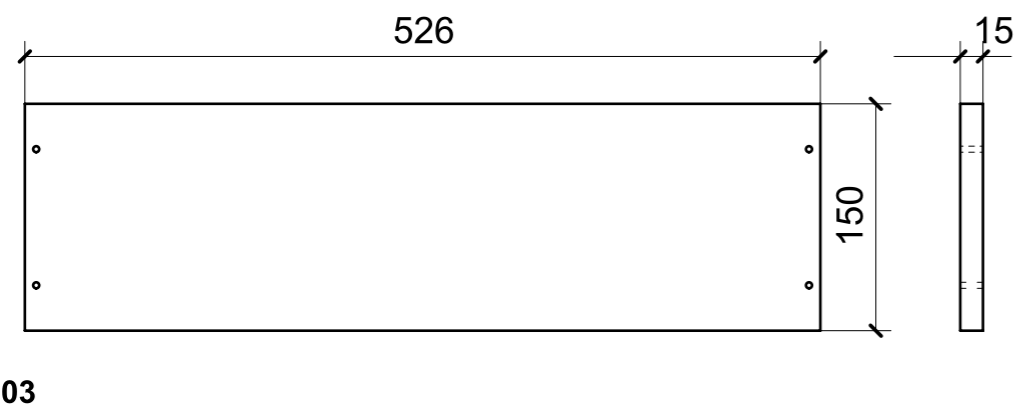
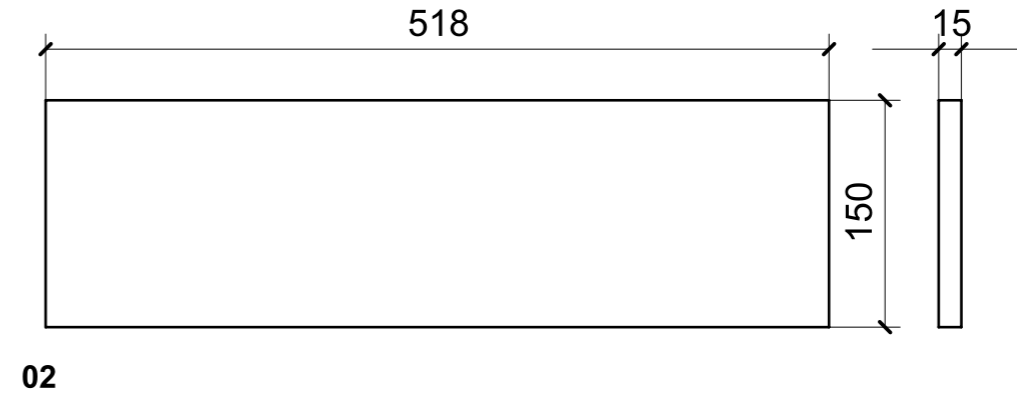
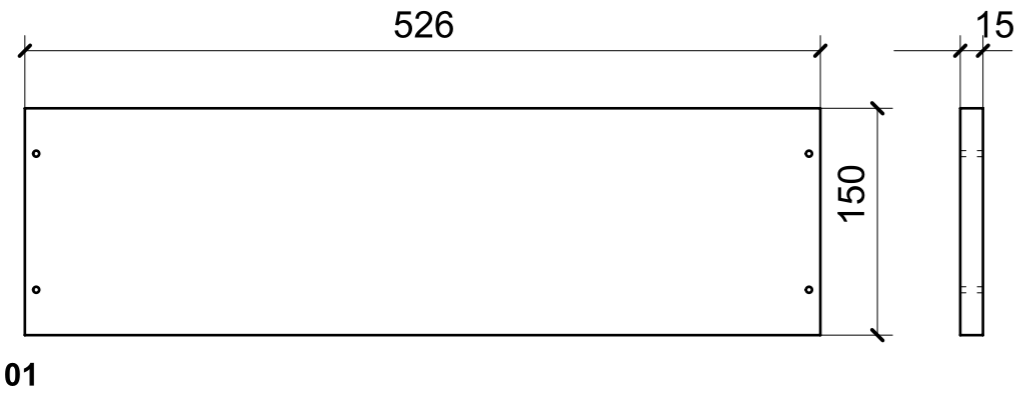

LOCALE	CODICE	DESCRIZIONE COMPONENTE	FINITURA	Q.TA
CABINA VIP	MD299_I01_VS01	RIV.PARETE DX POPPA	OKUME' GREZZO	1

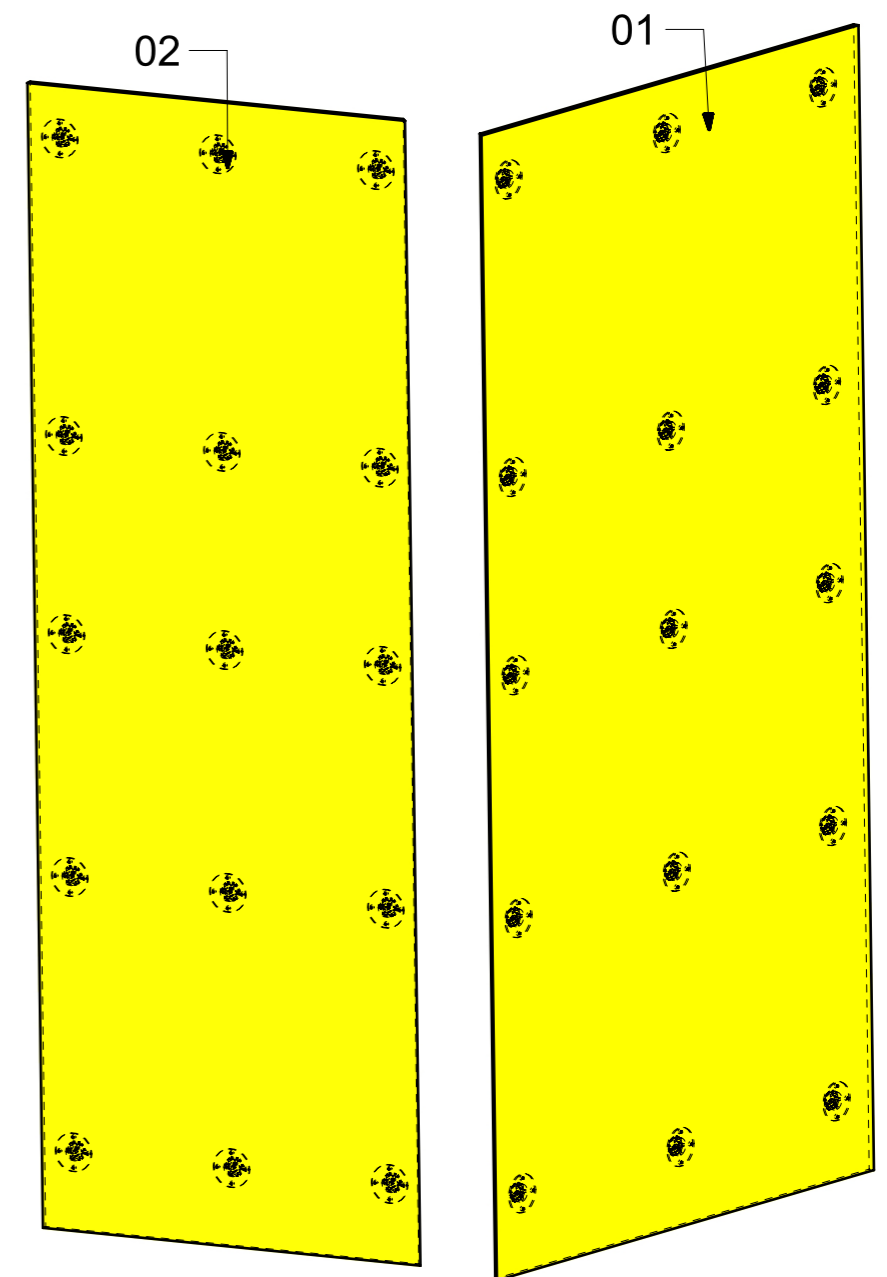
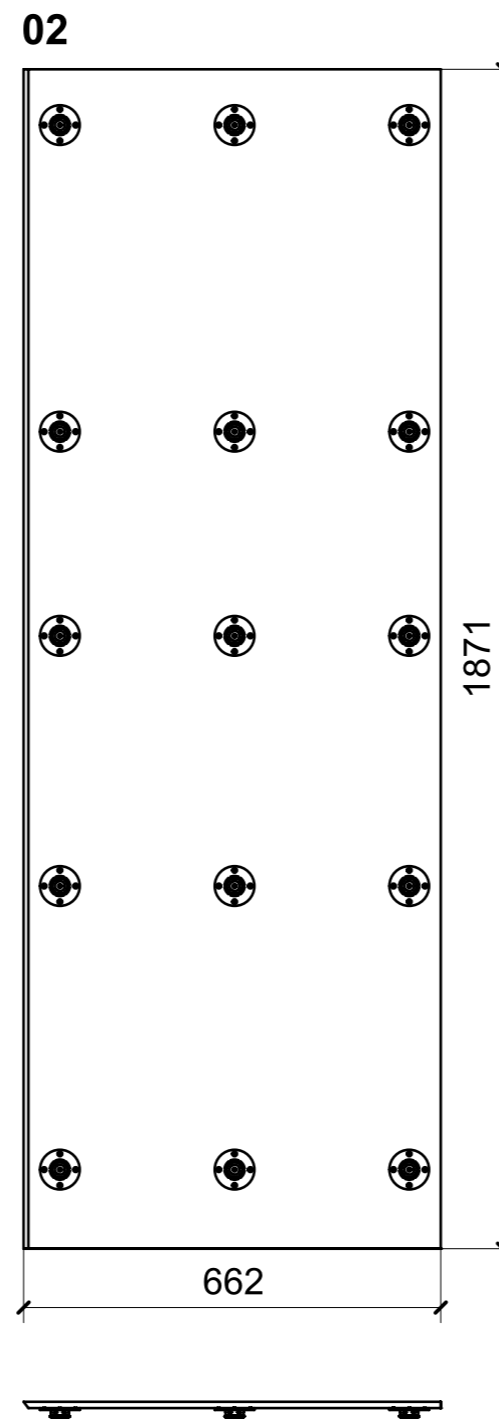
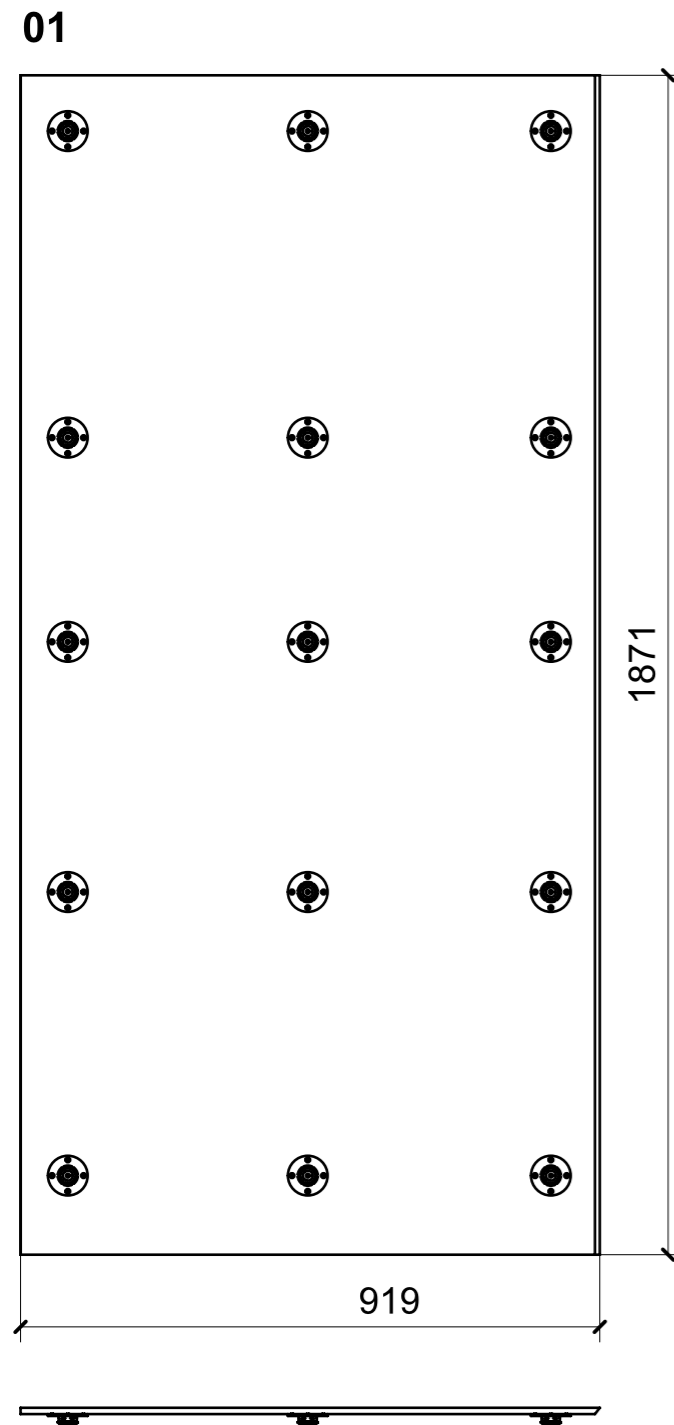

FERRAMENTA	QTY
FITLOCK M_MASCHERPA_3MM_6020202101	30

LOCALE	CODICE	DESCRIZIONE COMPONENTE	FINITURA	Q.TA
CABINA VIP	MD299_I01_VV01	CUSCINO E TESTALETTO	OKUME' GREZZO	1

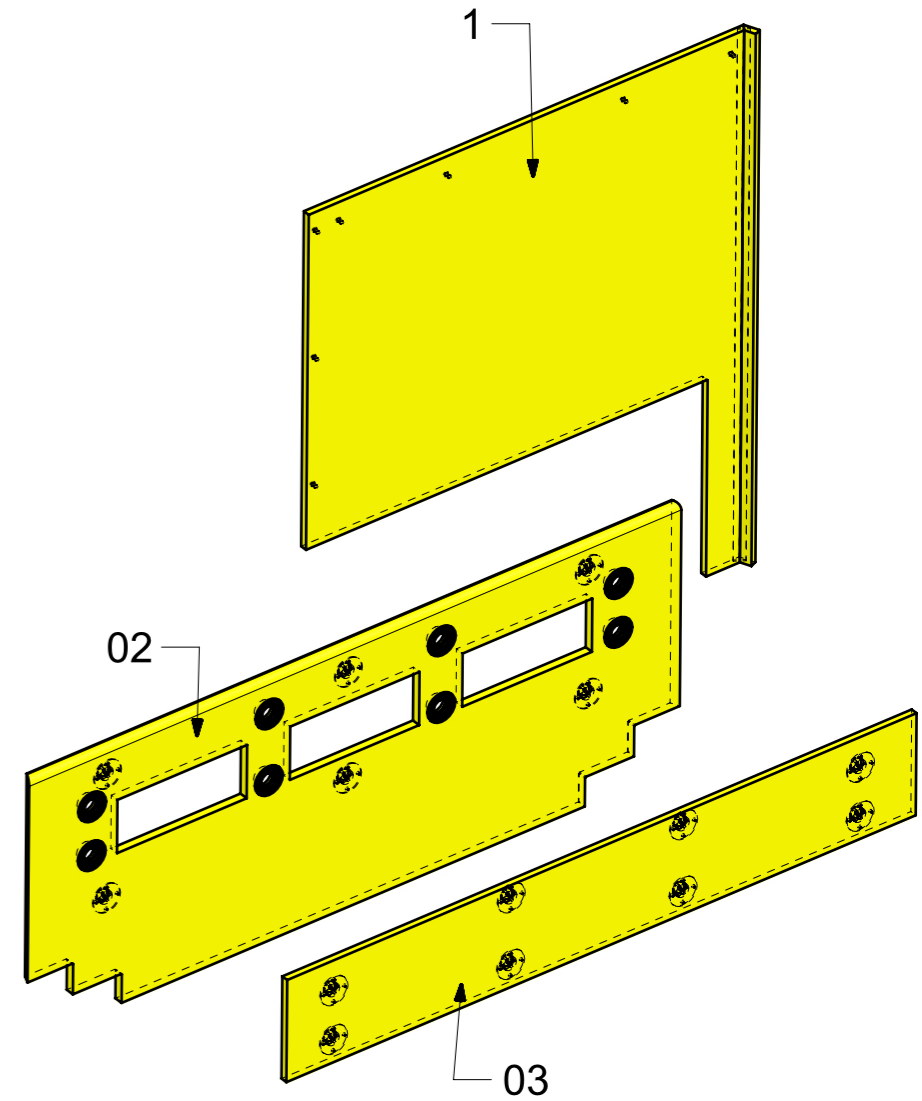
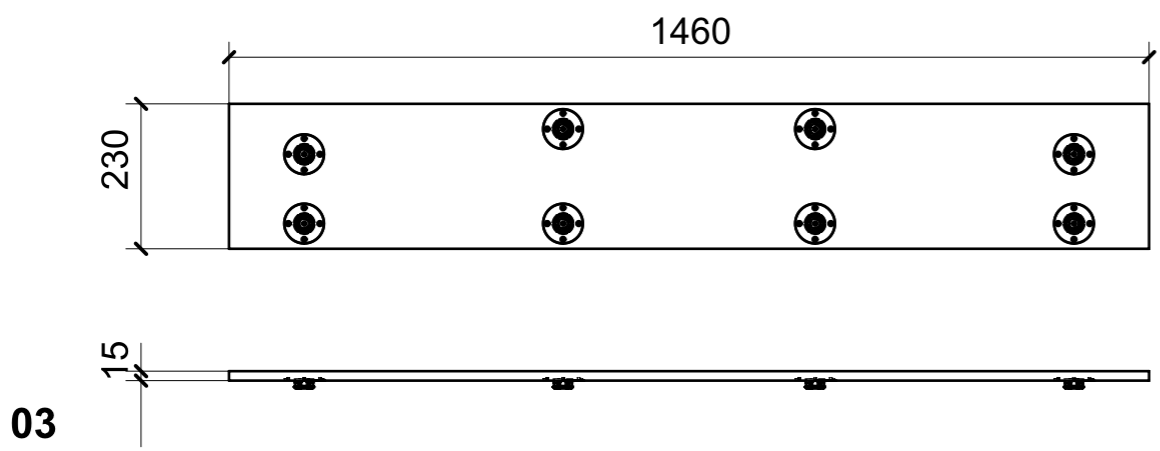
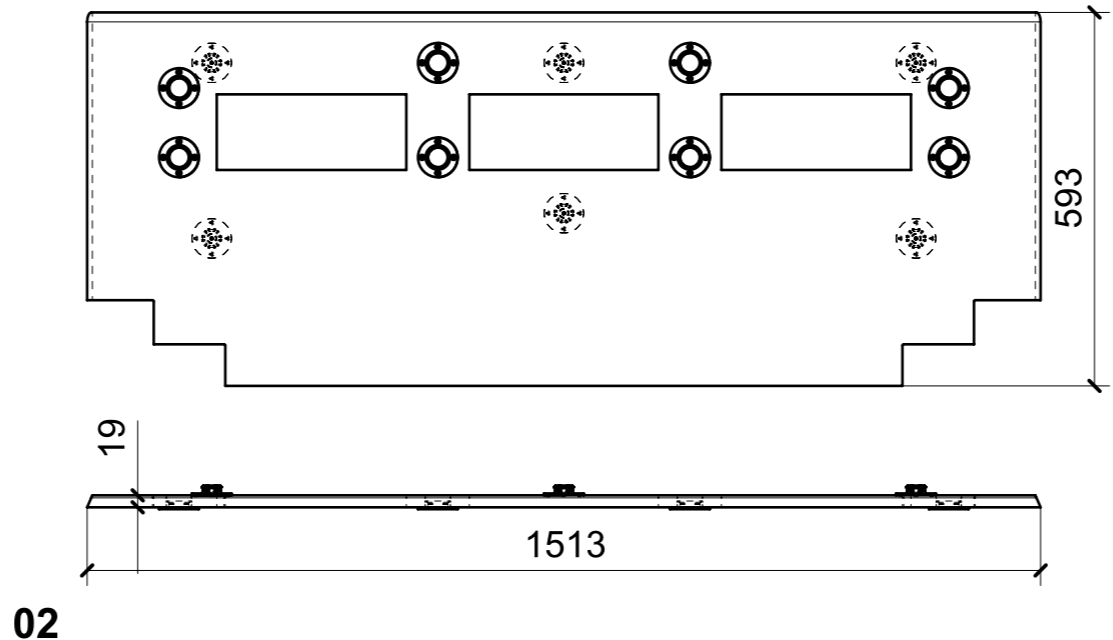
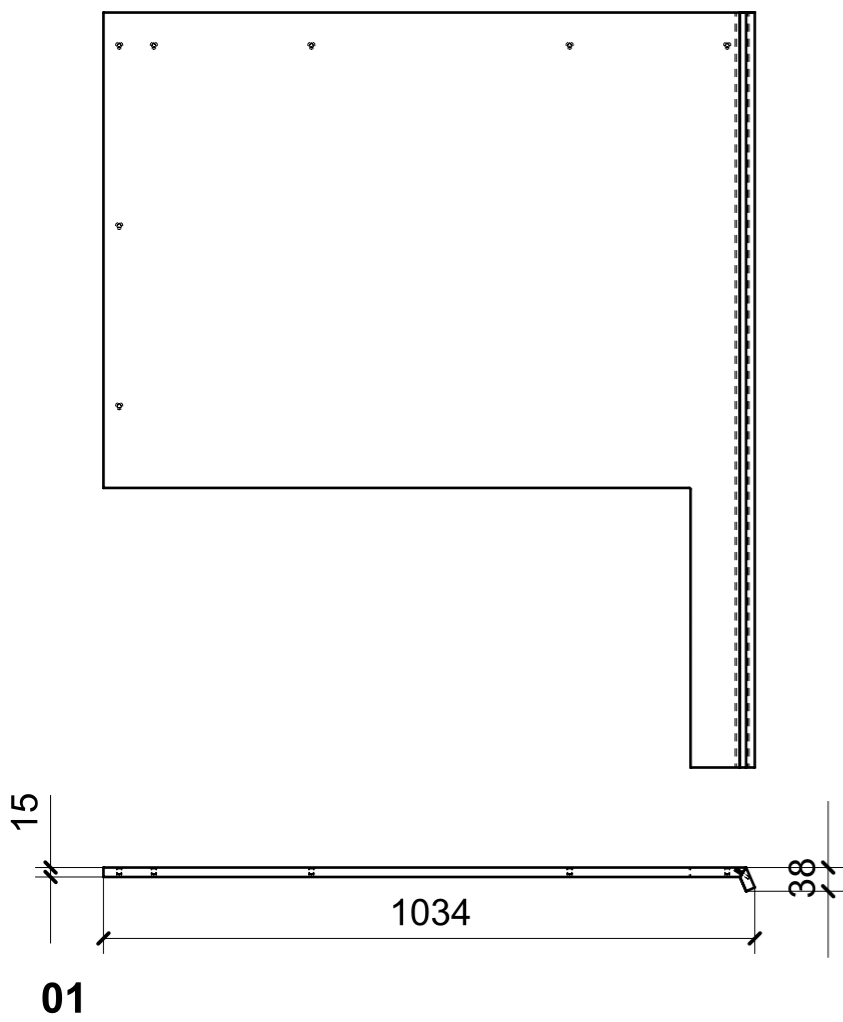

FERRAMENTA	QTY
BUSSOLA 6MA X 10 FORO DIAM.8	7
FITLOCK M_MASCHERPA_3MM_6020202101	14
FITLOCK F_MASCHERPA_6020101102	8

LOCALE	CODICE	DESCRIZIONE COMPONENTE	FINITURA	Q.TA
CABINA VIP	MD299_I01_VY01	CORNICE OBLO DX	OKUME' GREZZO	1

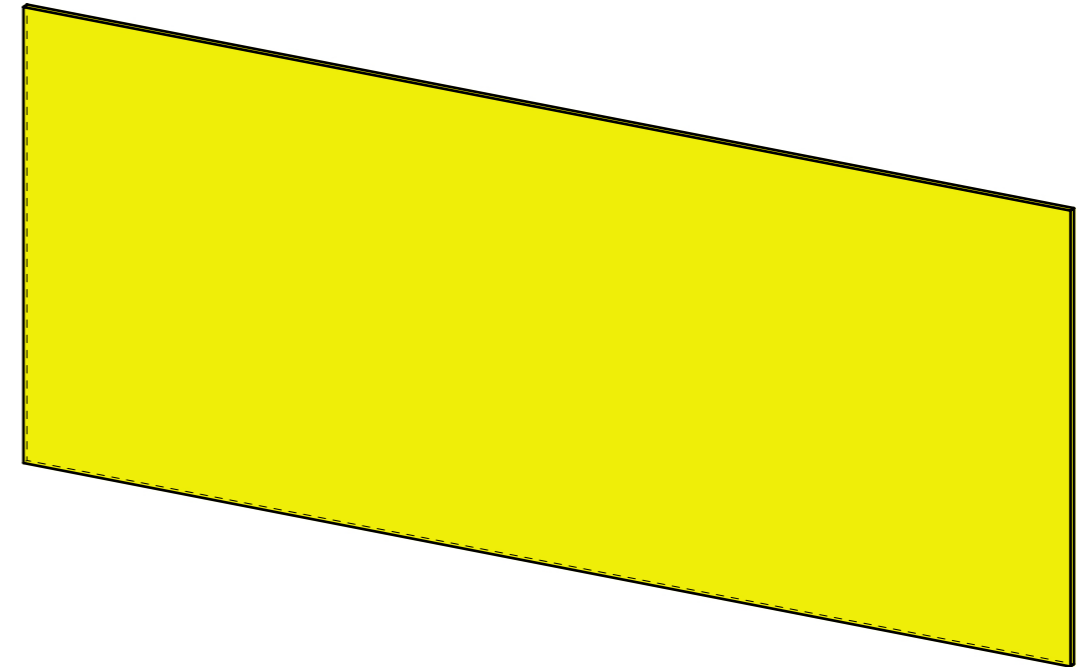
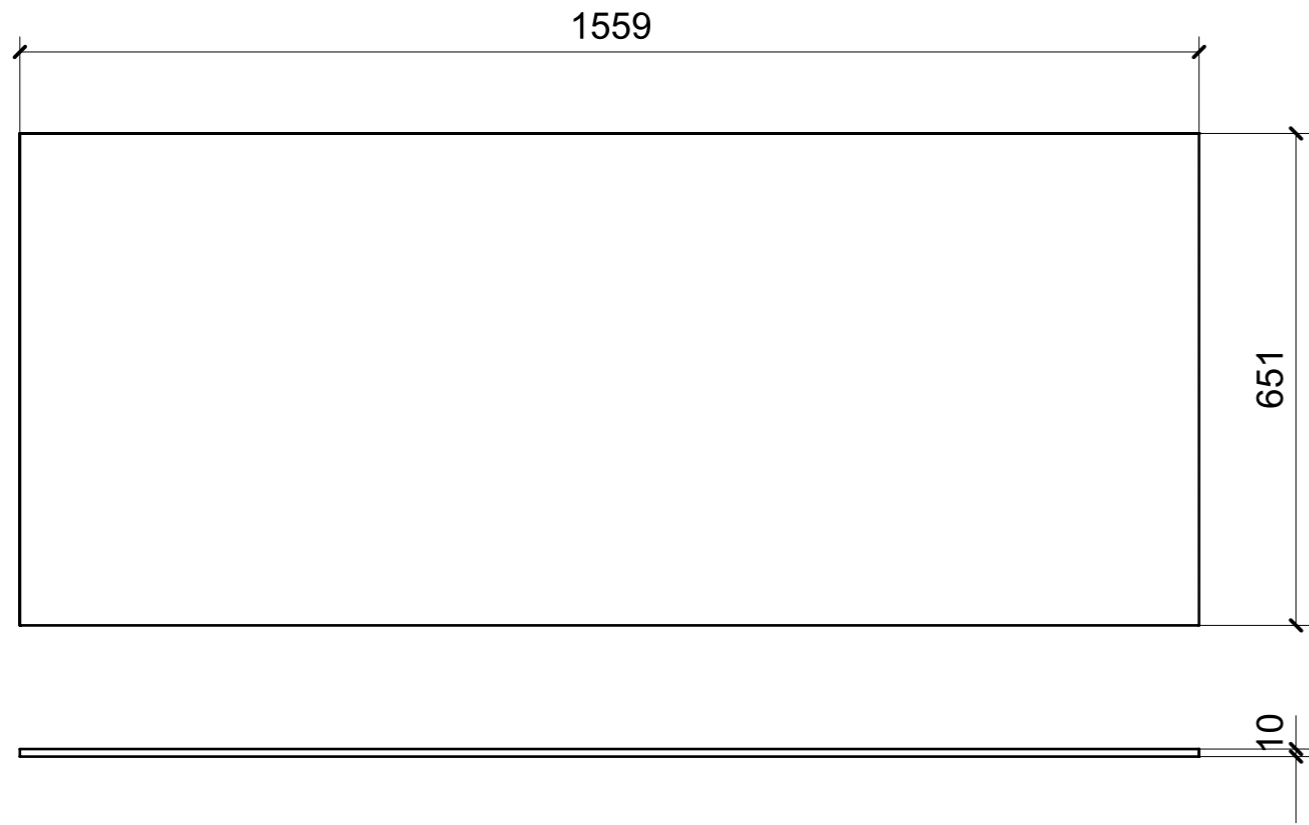

LOCALE	CODICE	DESCRIZIONE COMPONENTE	FINITURA	Q.TA
CABINA VIP	MD299_I01_VZ01	CORNICE OBLO SX	OKUME' GREZZO	1

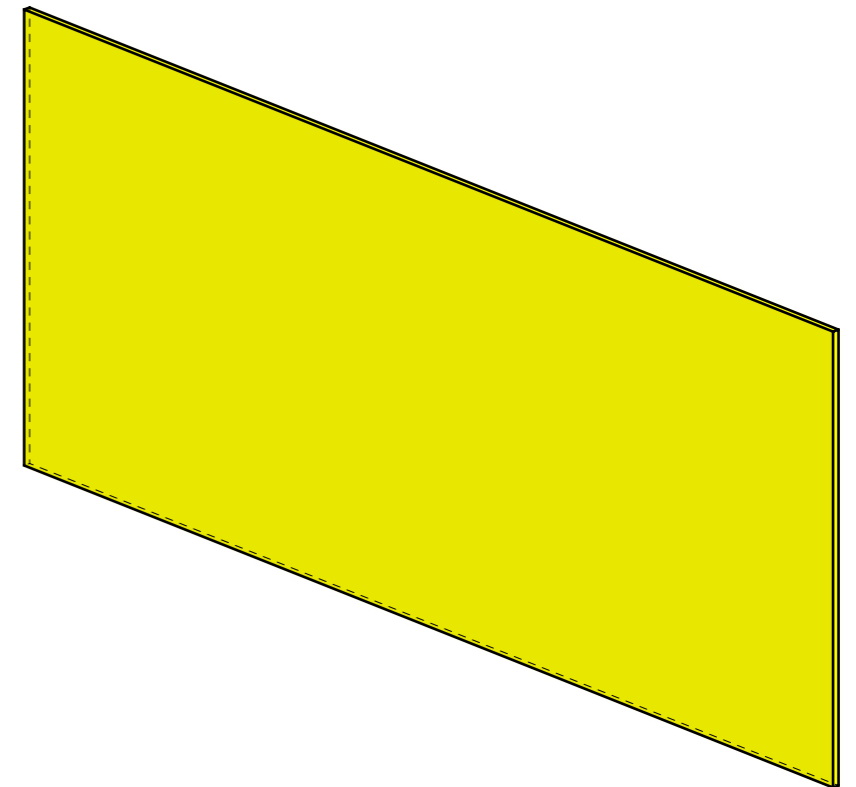
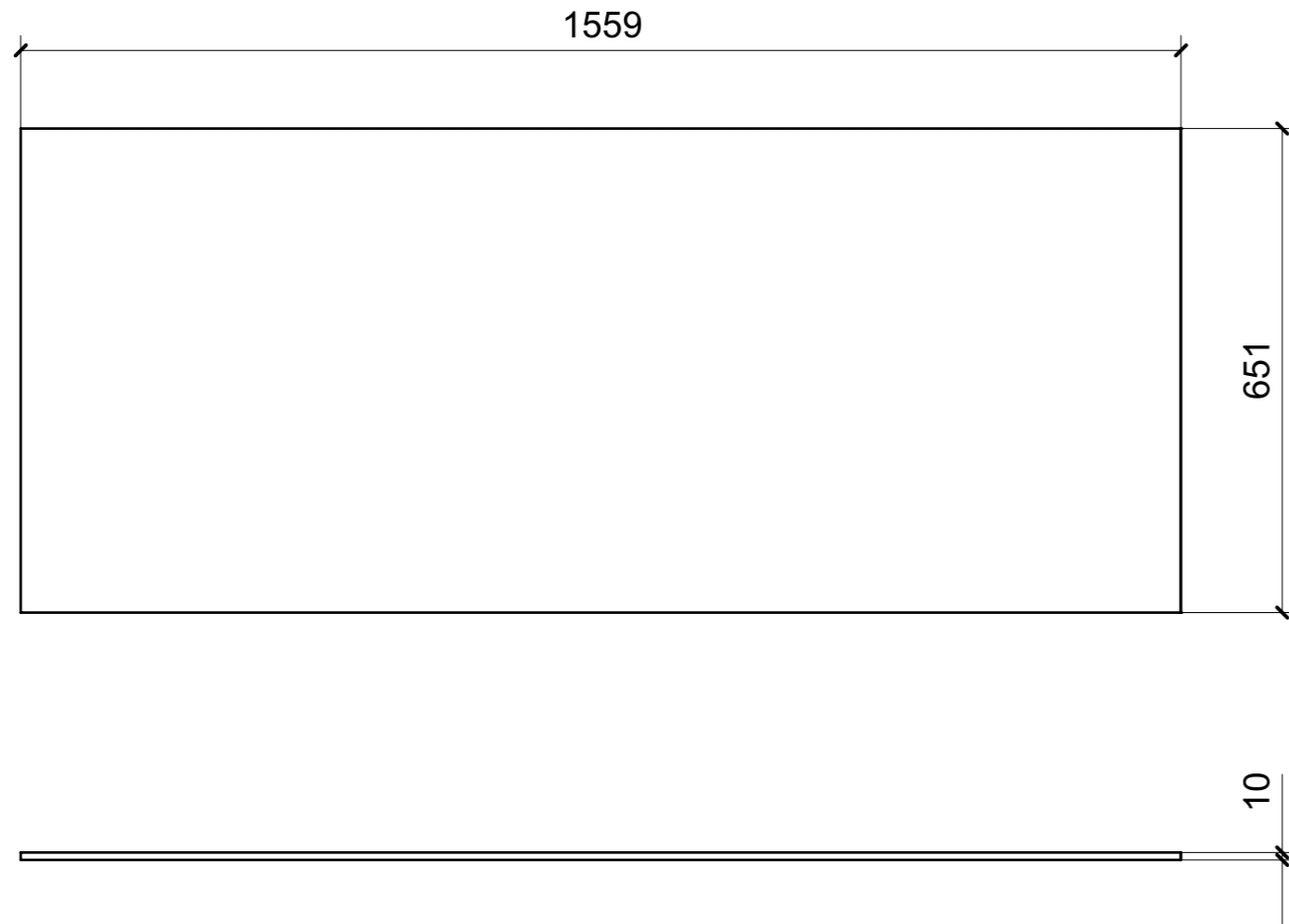

LOCALE	CODICE	DESCRIZIONE COMPONENTE	FINITURA	Q.TA
BAGNO VIP	MD299_I01_JC01	STRUTTURA CIELINO	OKUME' GREZZO	1

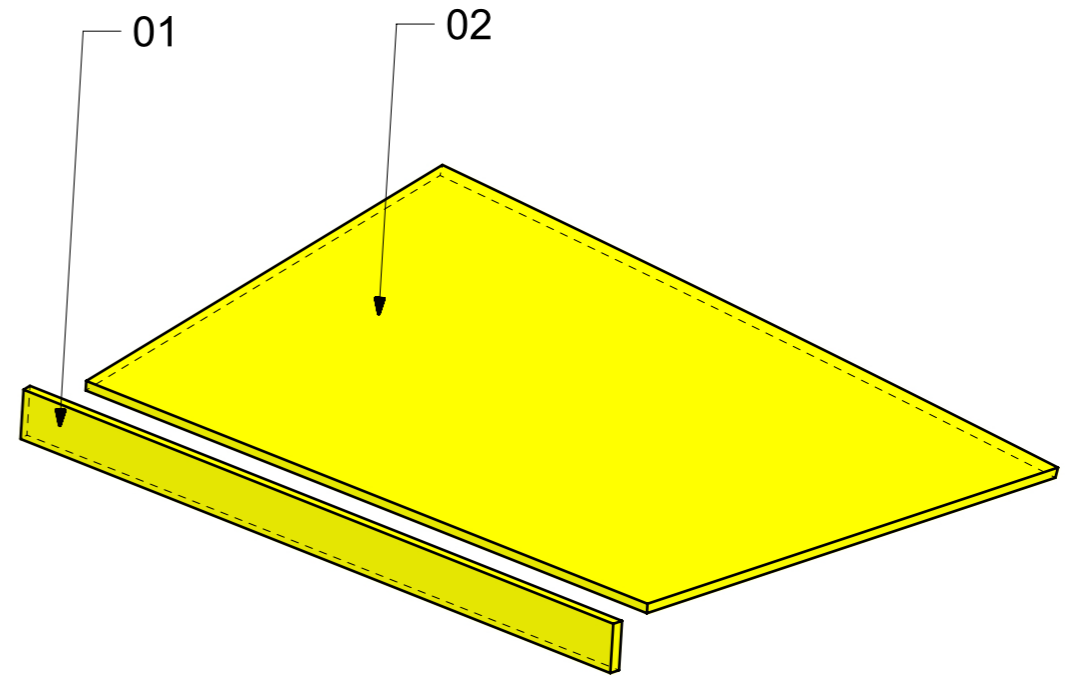
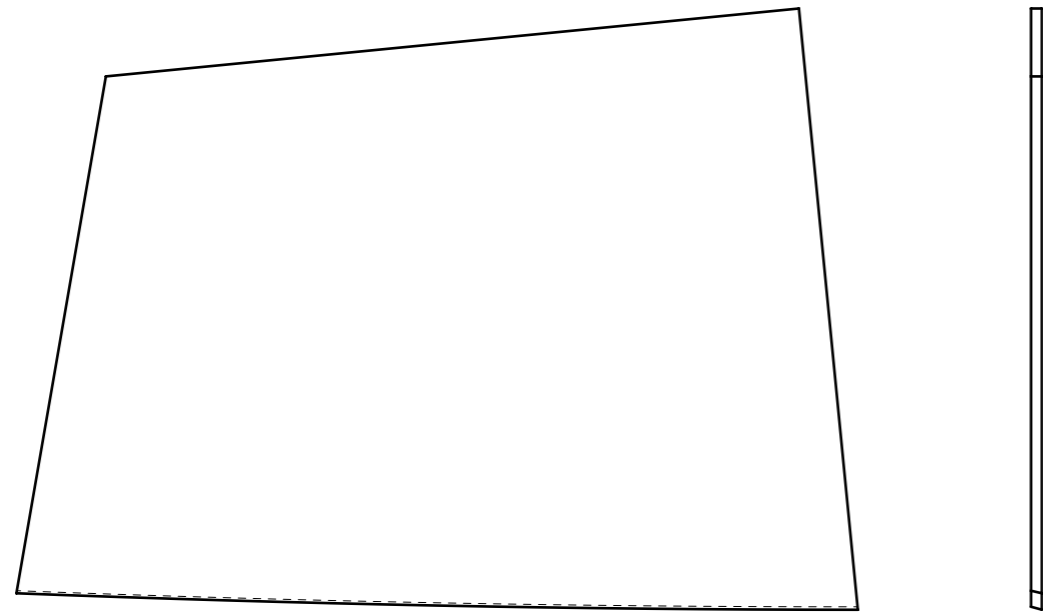
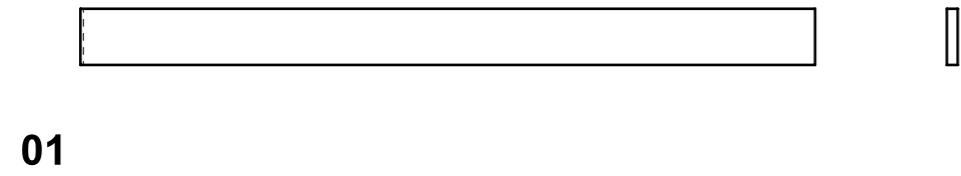

LOCALE	CODICE	DESCRIZIONE COMPONENTE	FINITURA	Q.TA
BAGNO VIP	MD299_I01_JN01	PANNELLO OBLO'	OKUME' GREZZO	1

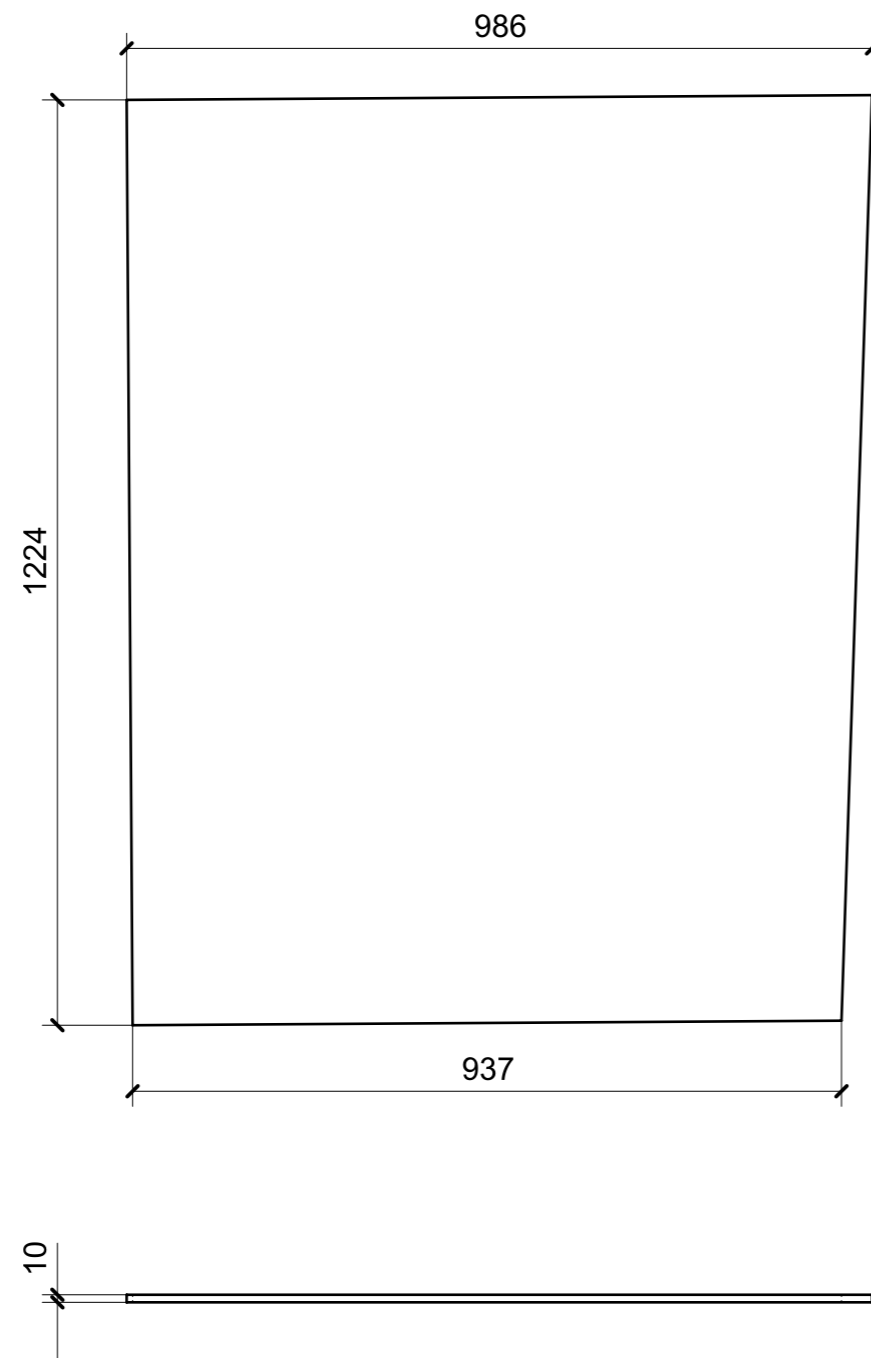

01

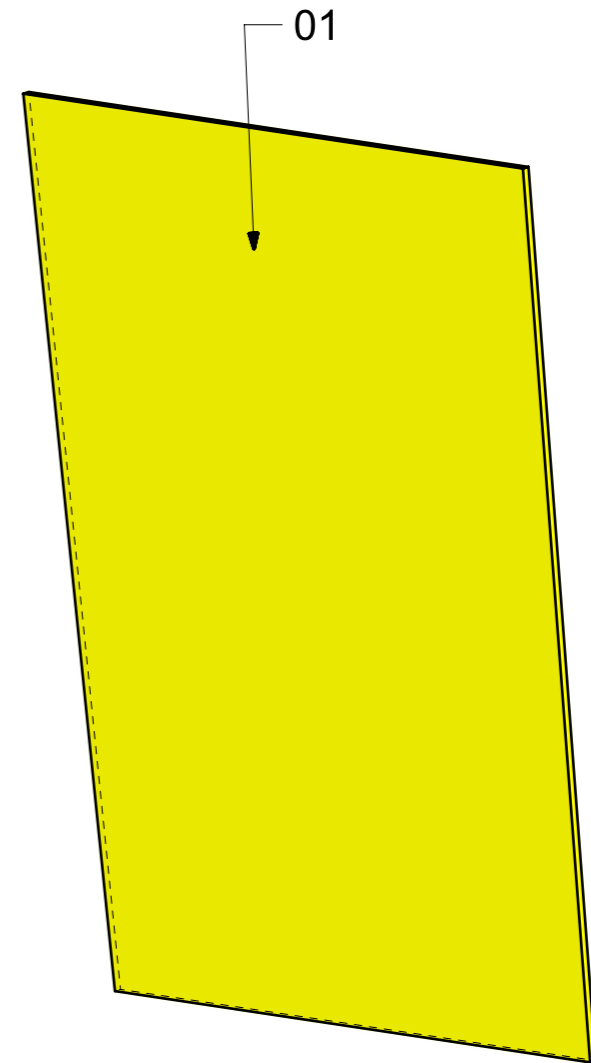

LOCALE	CODICE	DESCRIZIONE COMPONENTE	FINITURA	Q.TA
CABINA OSPITI DX	MD299_I01_RB01	BASE LETTO DX	OKUME' GREZZO	1

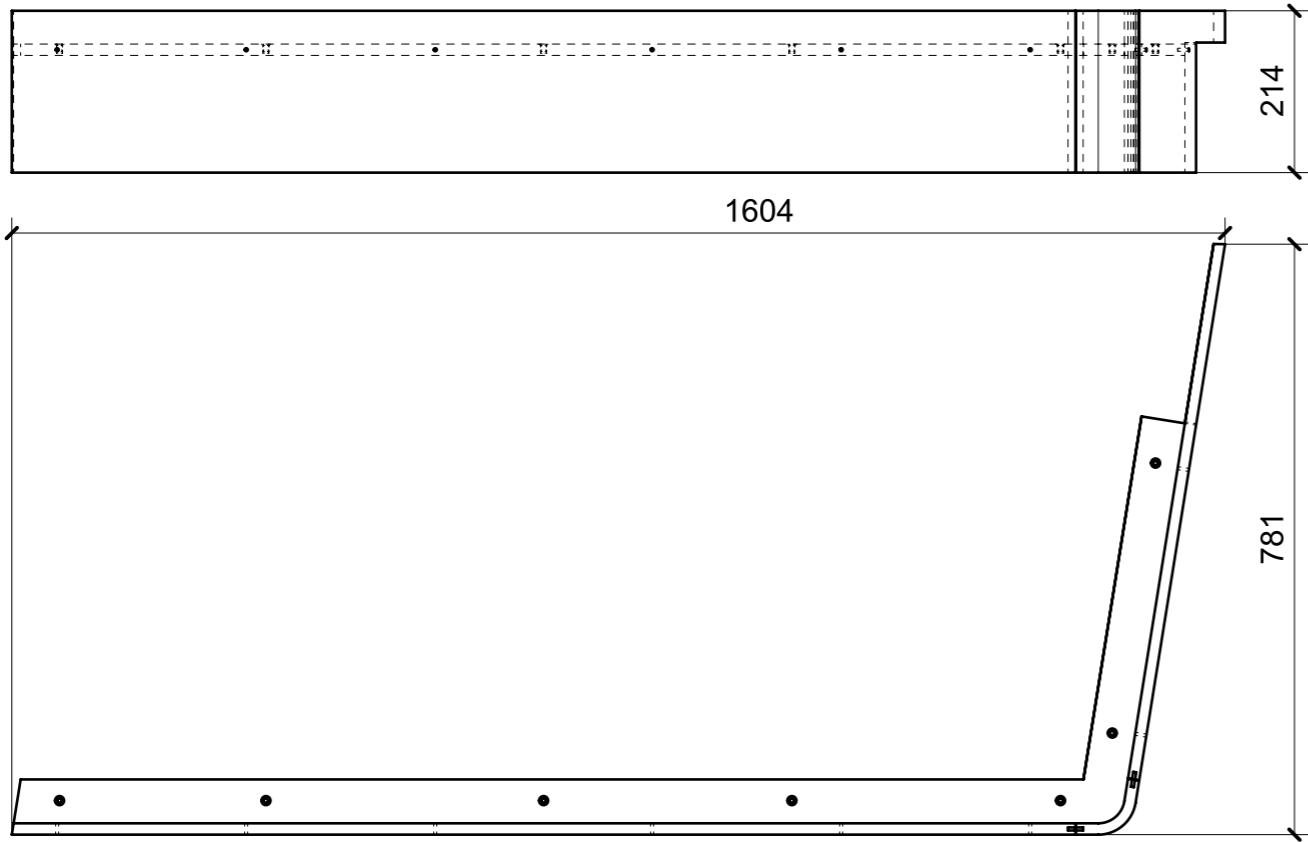

01

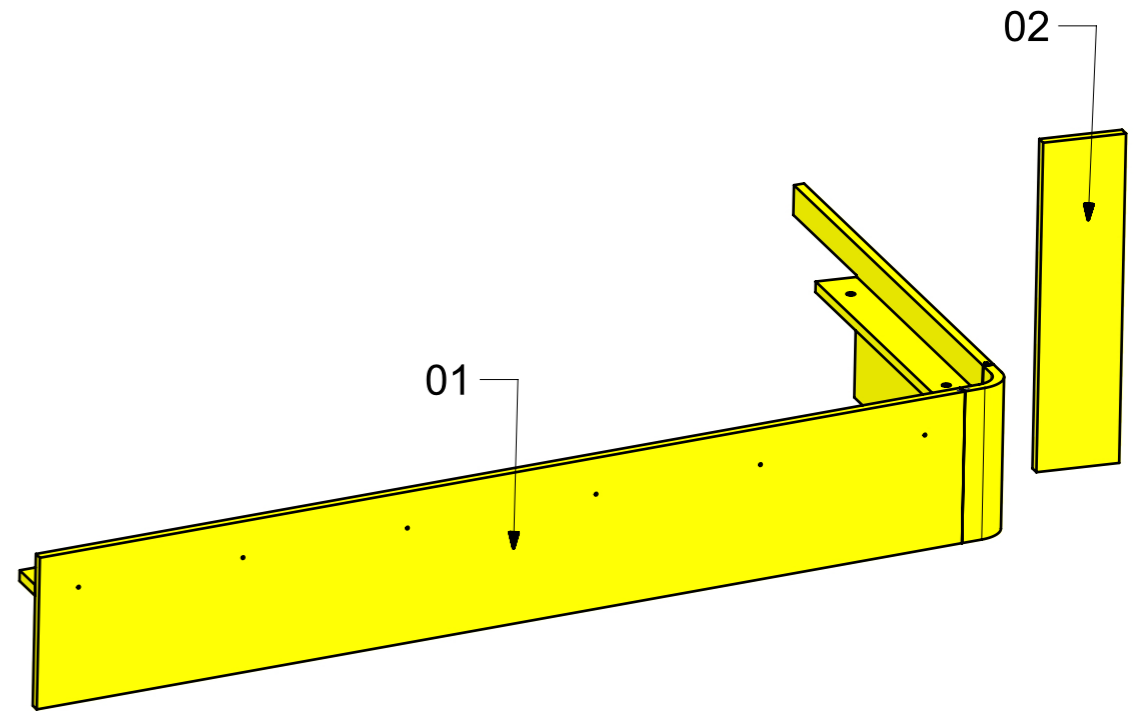

FERRAMENTA	QTY
BUSSOLA 6MA X 10 FORO DIAM.8	7

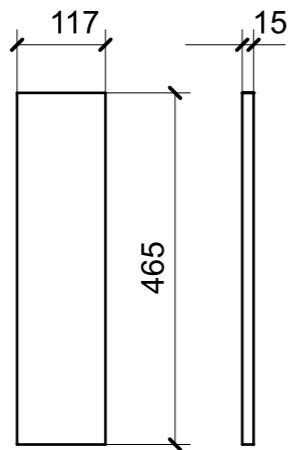

02

LOCALE	CODICE	DESCRIZIONE COMPONENTE	FINITURA	Q.TA
CABINA OSPITI DX	MD299_I01_RC01	COMODINO	OKUME' GREZZO	1

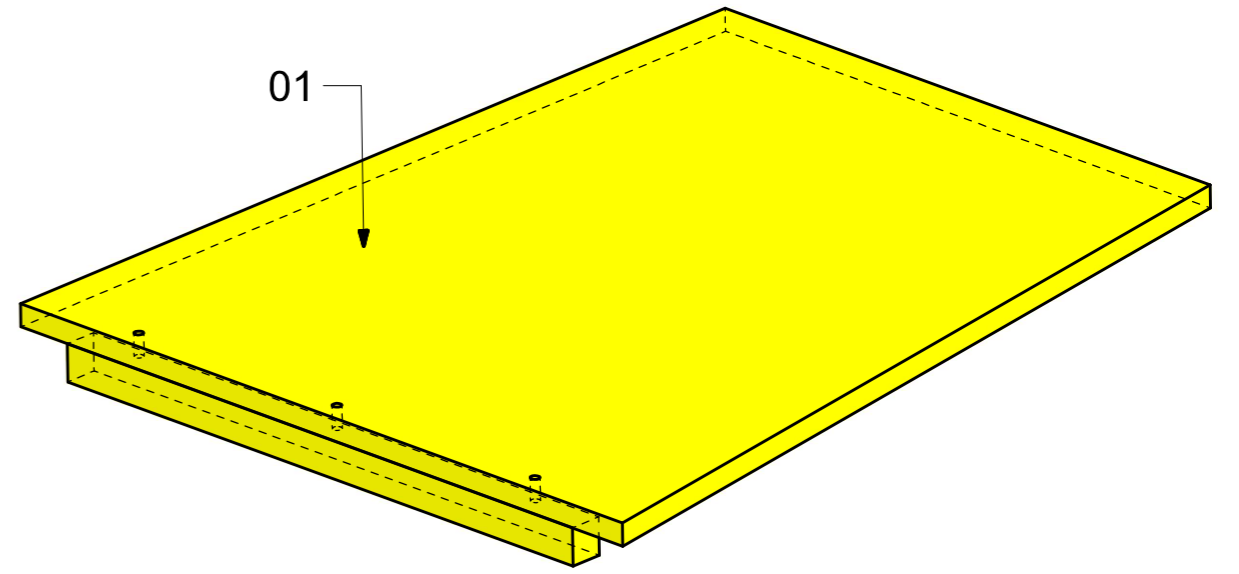
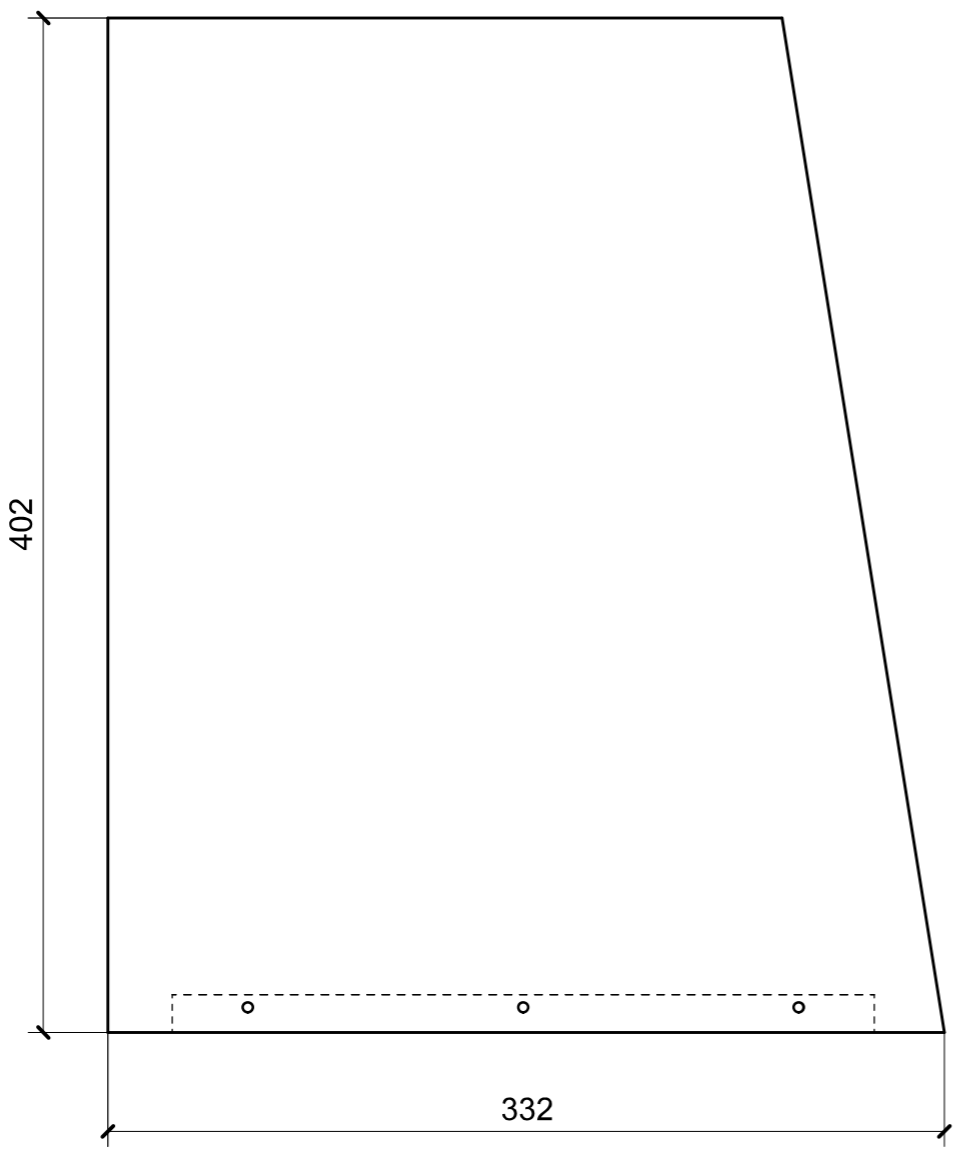
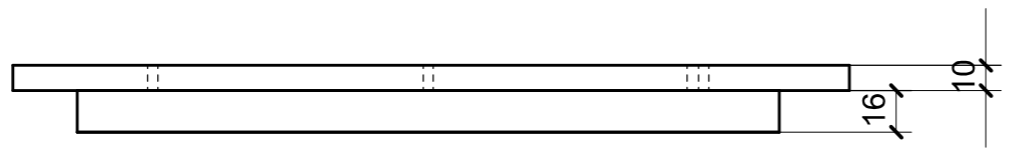

LOCALE	CODICE	DESCRIZIONE COMPONENTE	FINITURA	Q.TA
CABINA OSPITI DX	MD299_I01_RD01	BASE LETTO SX	OKUME' GREZZO	1

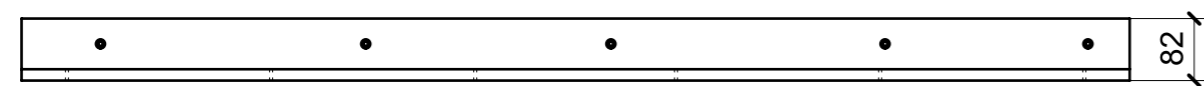
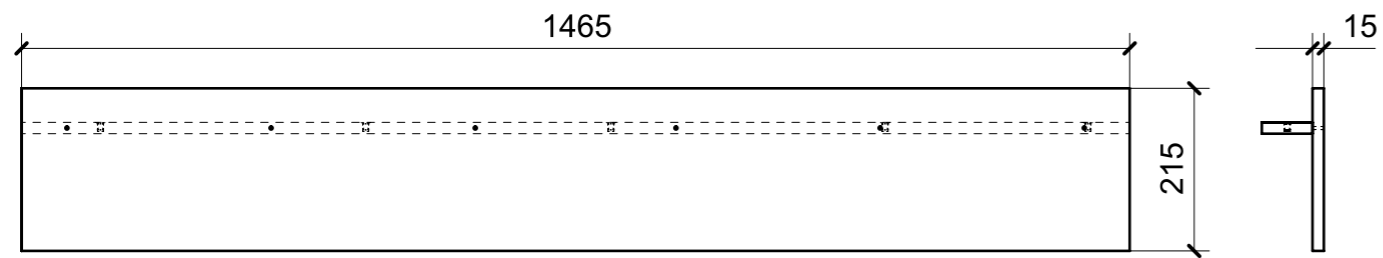

01

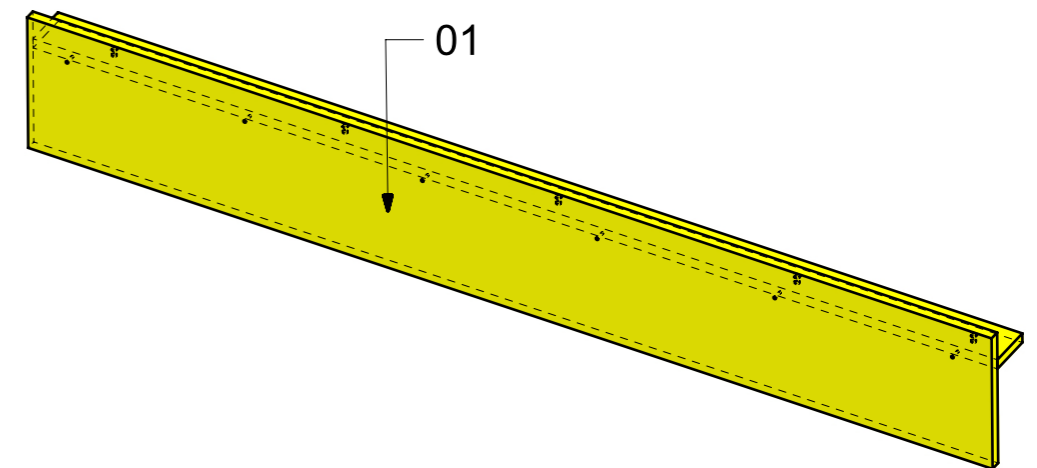

FERRAMENTA	QTY
BUSSOLA 6MA X 10 FORO DIAM.8	5

LOCALE	CODICE	DESCRIZIONE COMPONENTE	FINITURA	Q.TA
CABINA OSPITI DX	MD299_I01_RE01	STRUTTURA TESTALETTO	OKUME' GREZZO	1

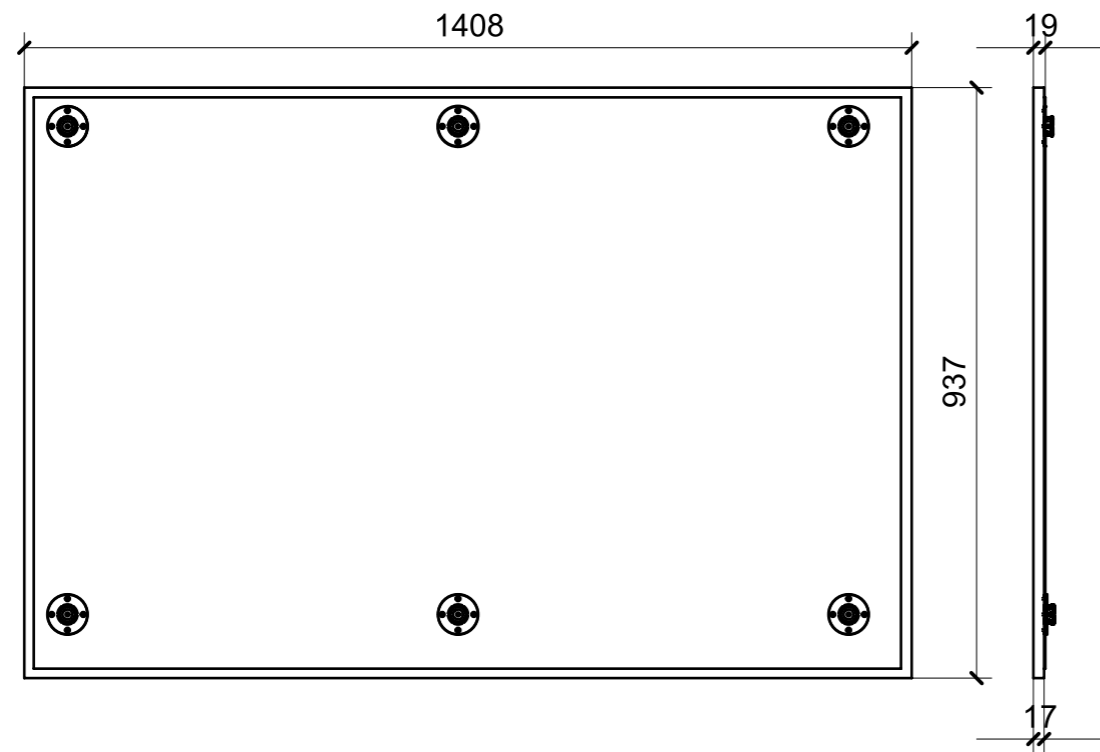

01

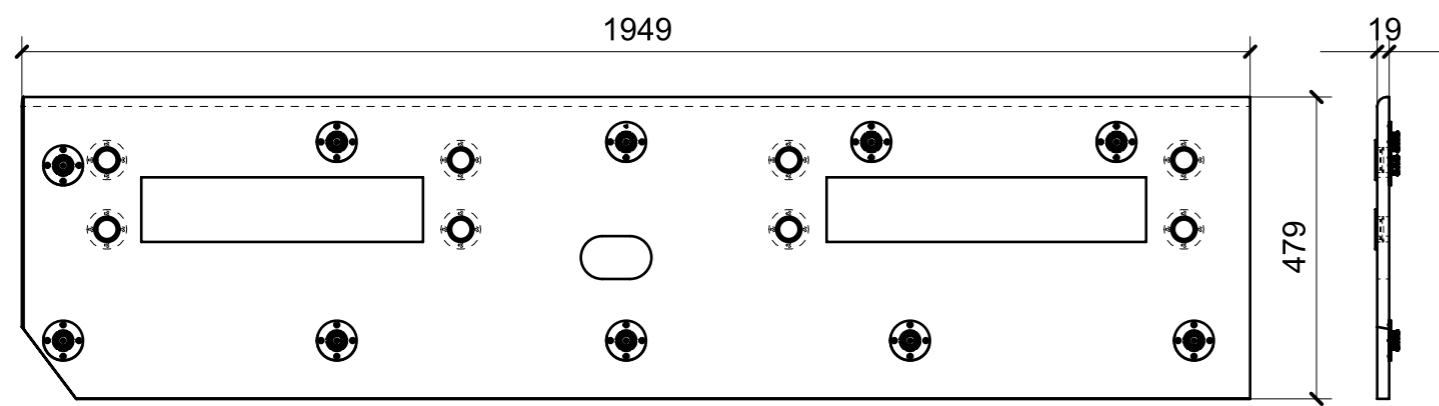

02

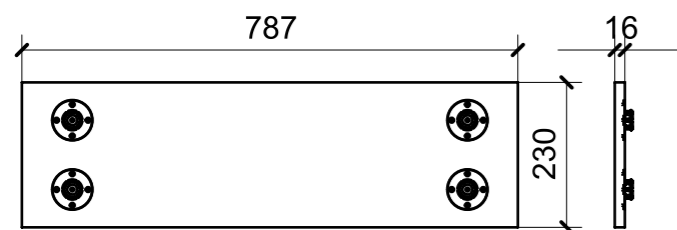

03

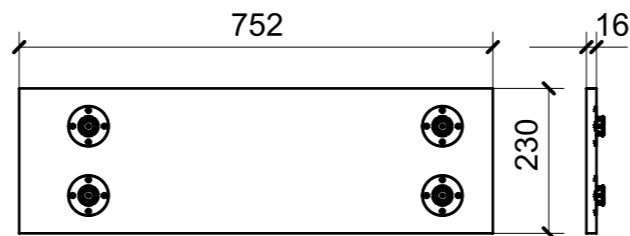

04

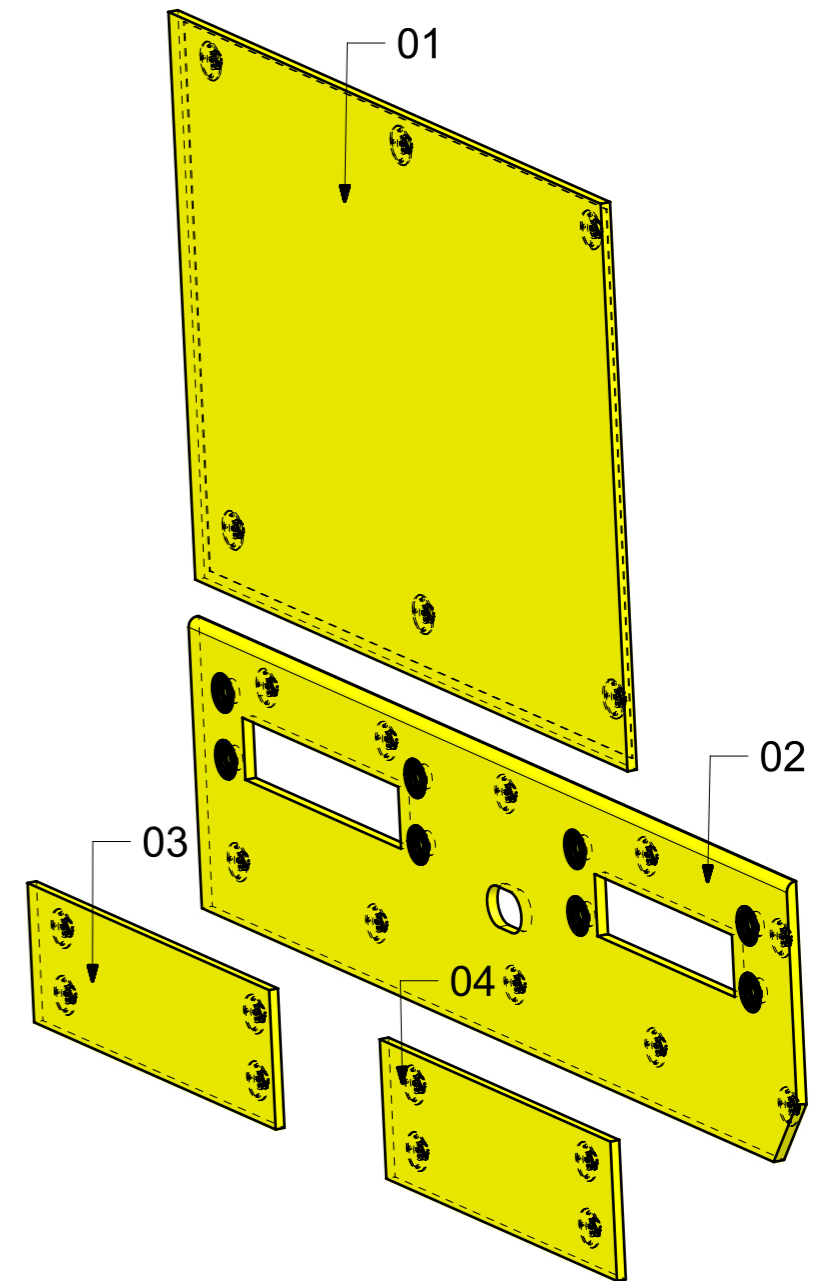

FERRAMENTA	QTY
FITLOCK M_MASCHERPA_3MM_6020202101	24
FITLOCK F_MASCHERPA_6020101102	8

LOCALE	CODICE	DESCRIZIONE COMPONENTE	FINITURA	Q.TA
CABINA OSPITI DX	MD299_I01_RF01	PENSILE	OKUME' GREZZO	1

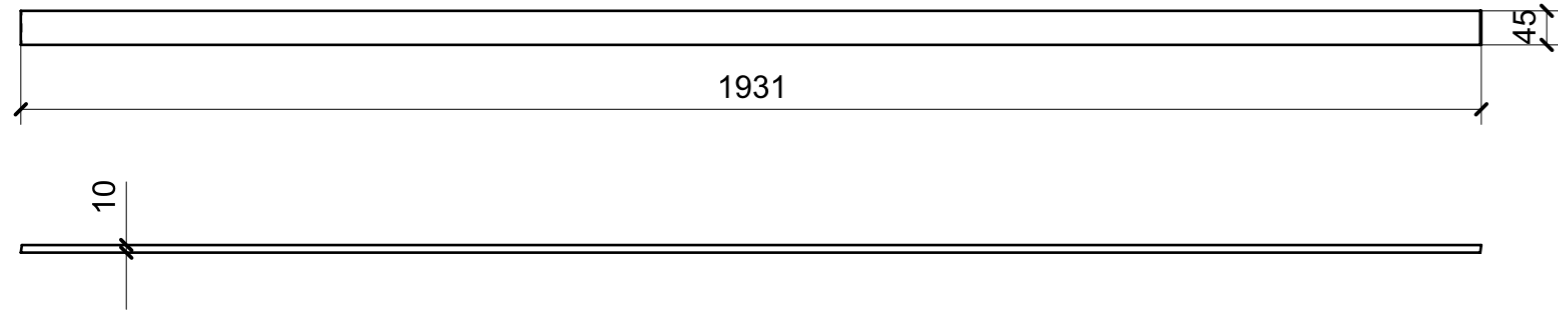

01

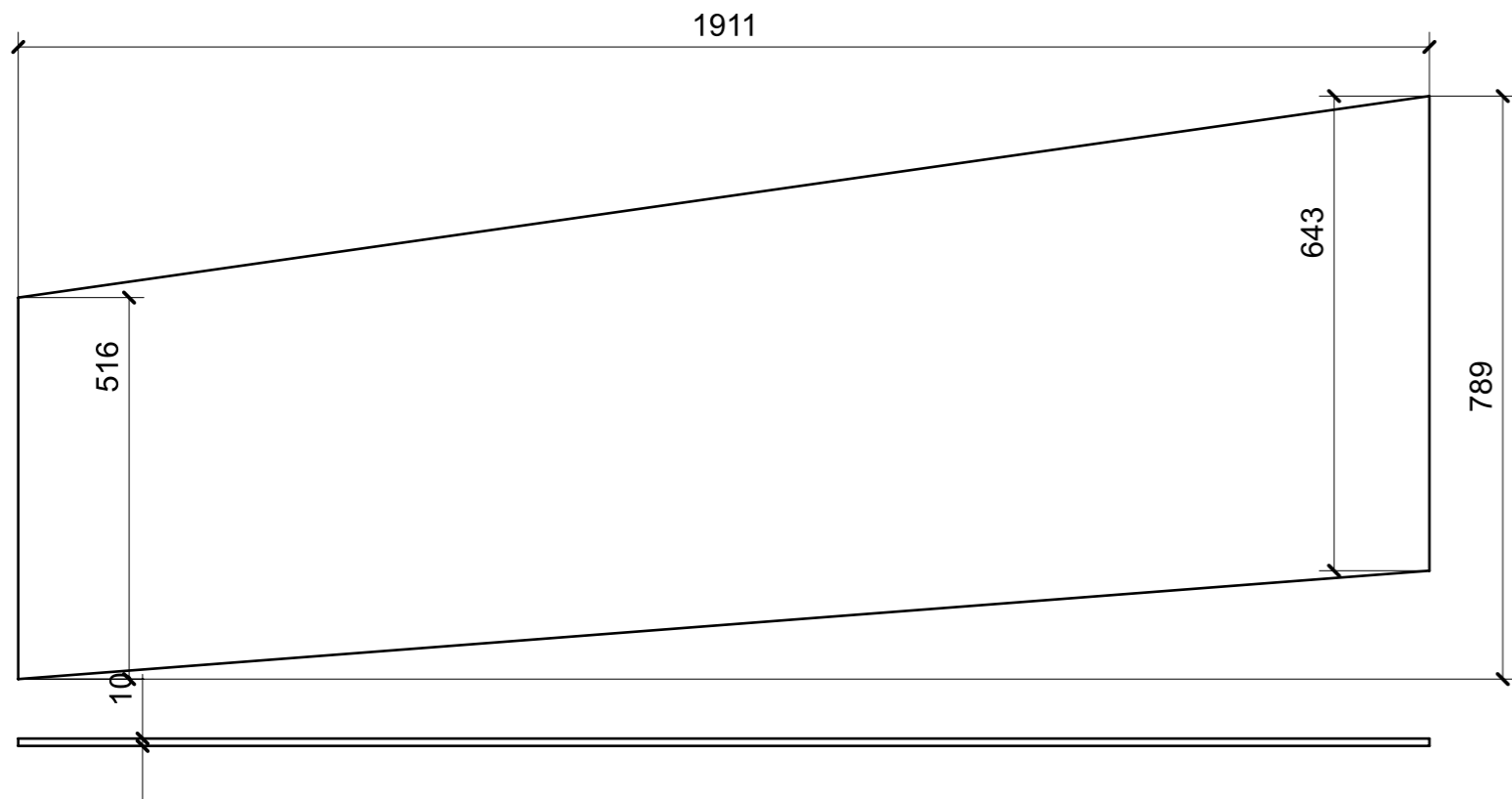

02

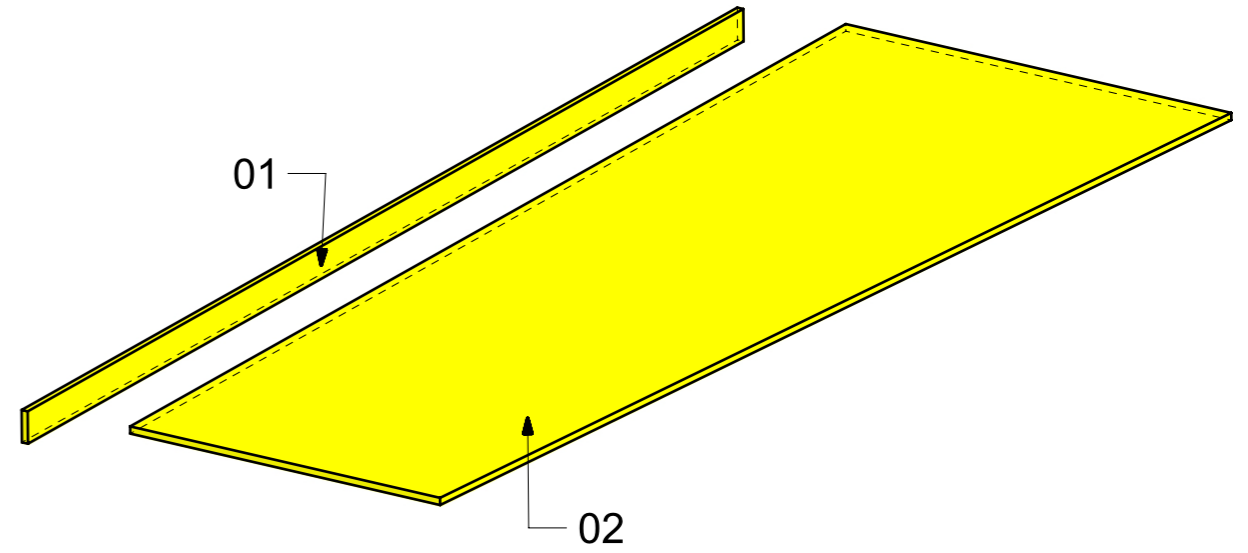

LOCALE	CODICE	DESCRIZIONE COMPONENTE	FINITURA	Q.TA
CABINA OSPITI DX	MD299_I01_RG01	COLLEGAMENTO BASSO MURATA	OKUME' GREZZO	1

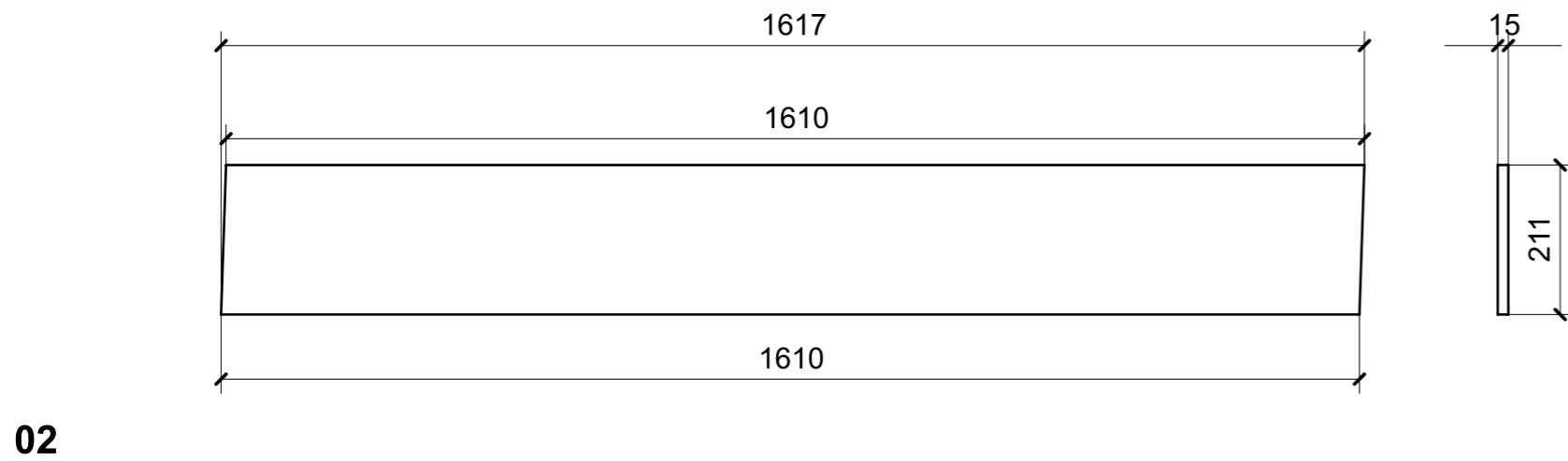
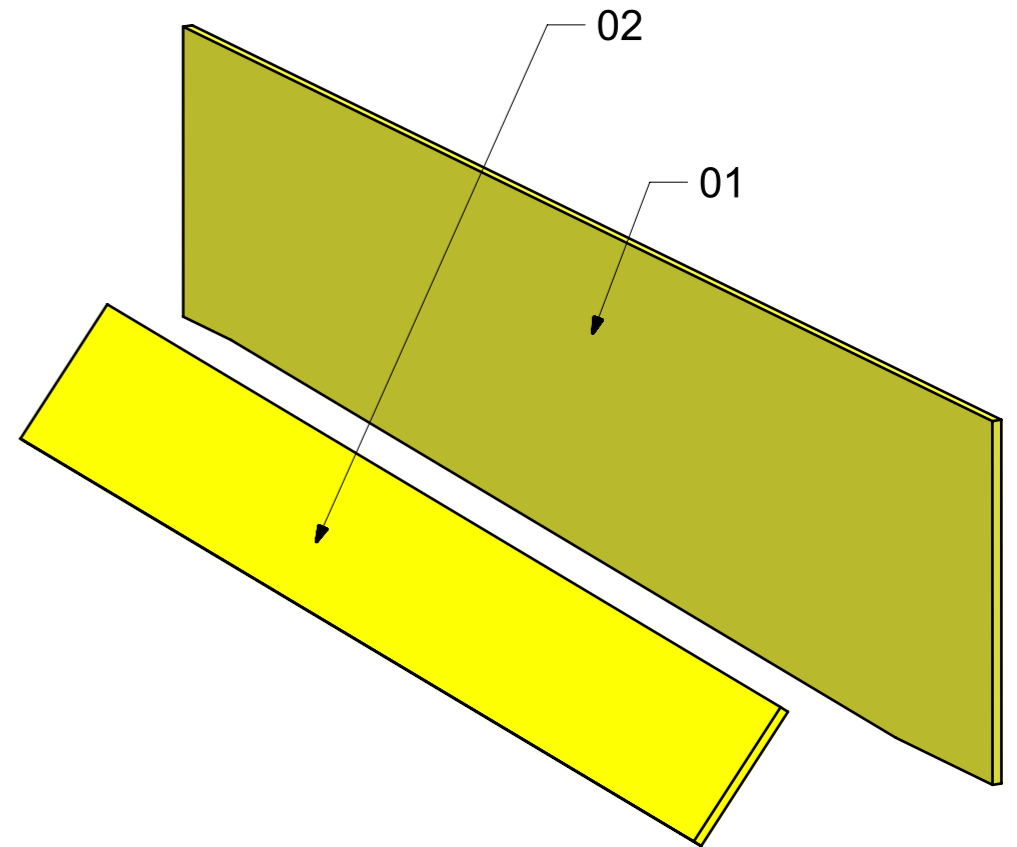
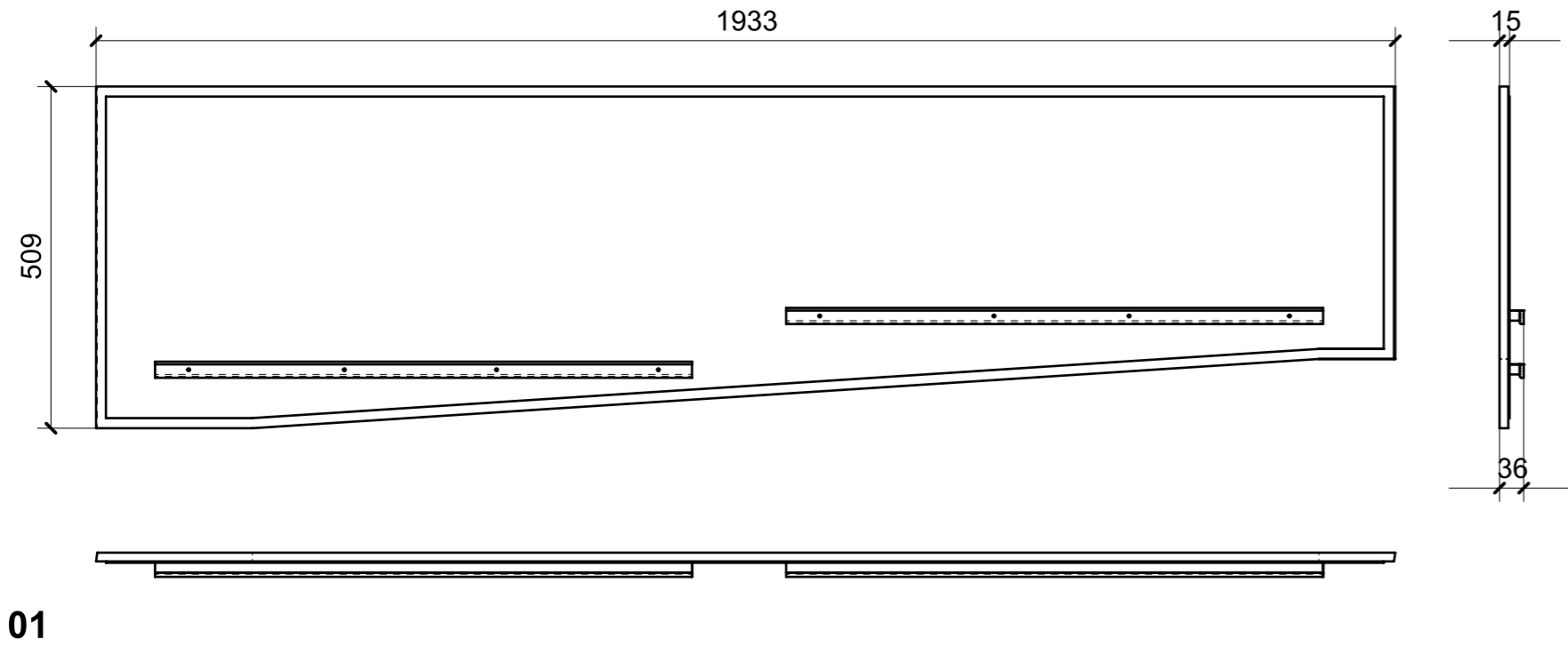

LOCALE	CODICE	DESCRIZIONE COMPONENTE	FINITURA	Q.TA
CABINA OSPITI DX	MD299_I01_RL01	RIV. PARETI	OKUME' GREZZO	1

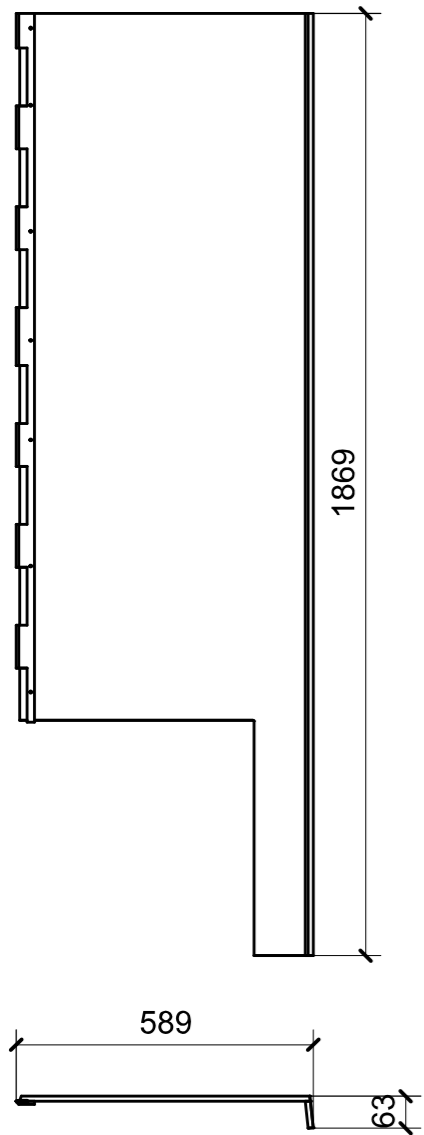

01

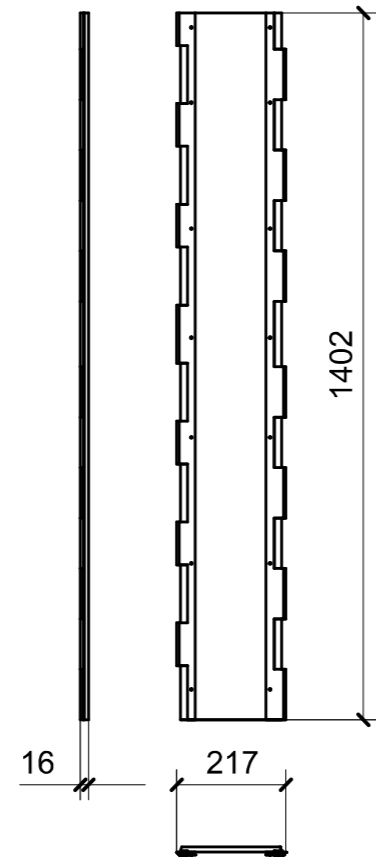

02

03

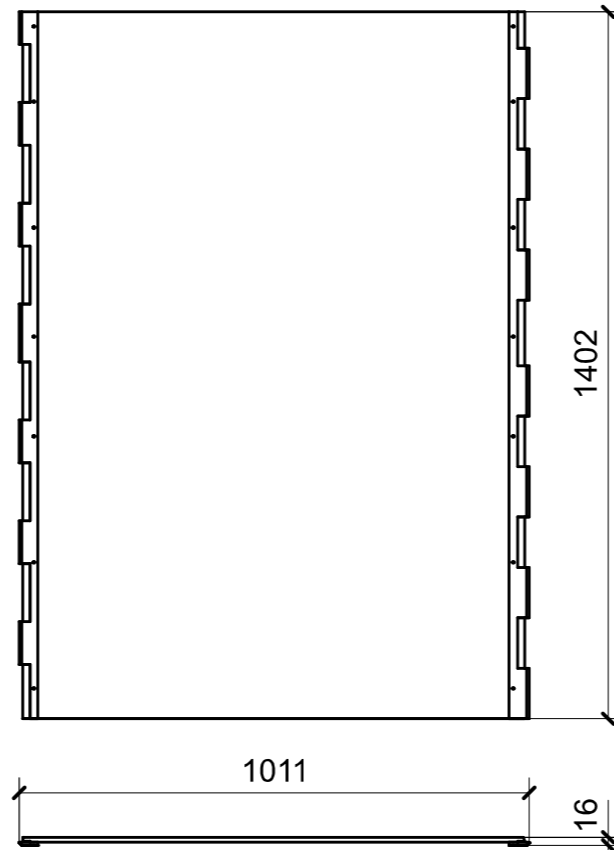

04

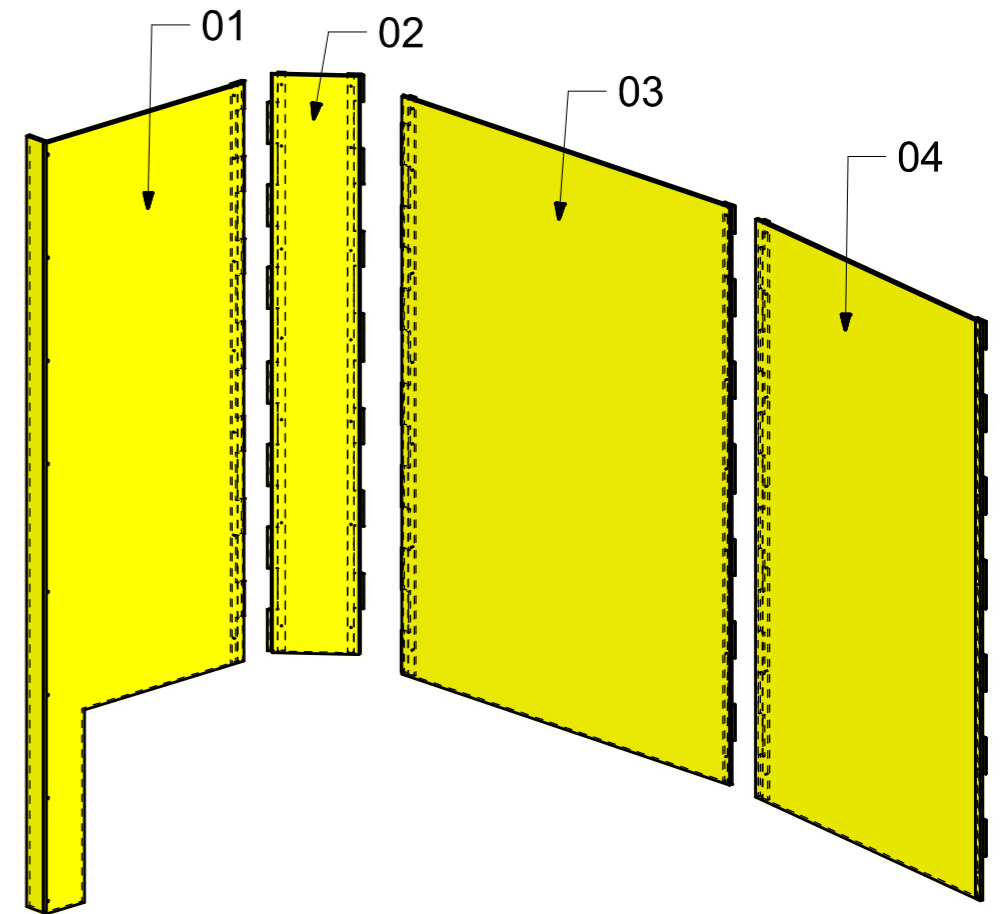
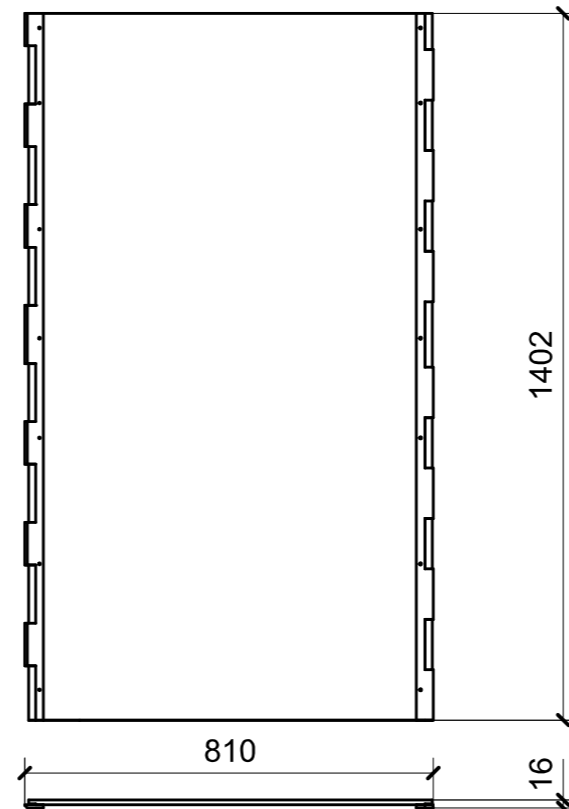

LOCALE	CODICE	DESCRIZIONE COMPONENTE	FINITURA	Q.TA
CABINA OSPITI DX	MD299_I01_RM01	PANNELLO OBLO'	OKUME' GREZZO	1

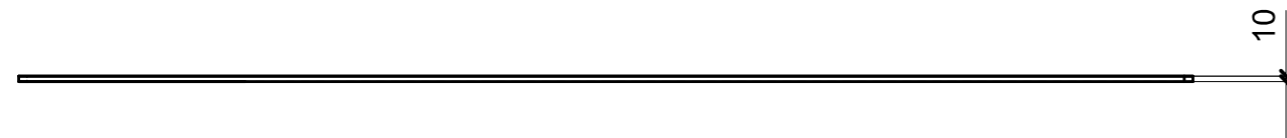
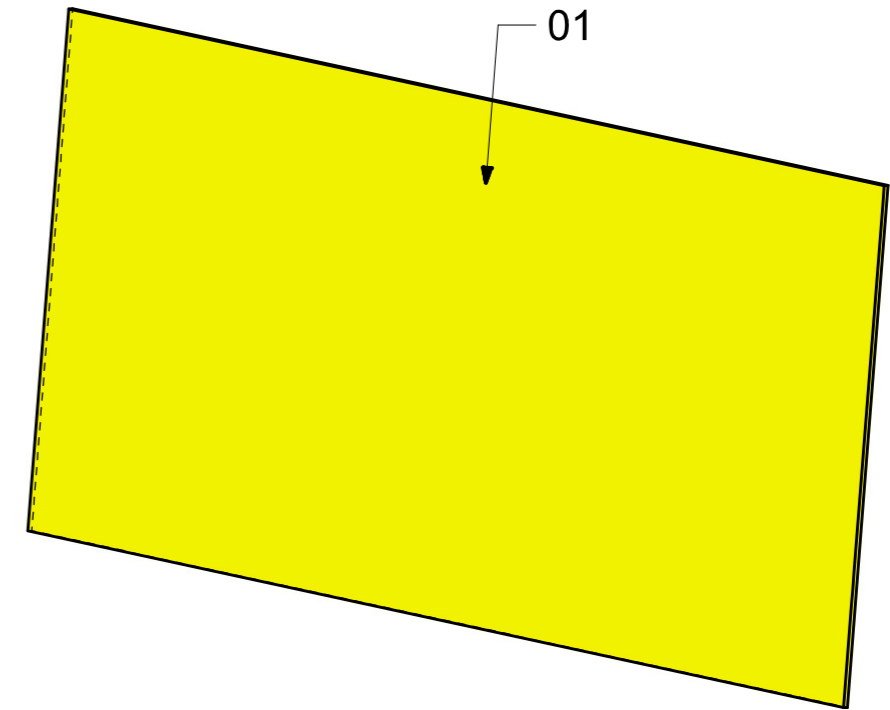
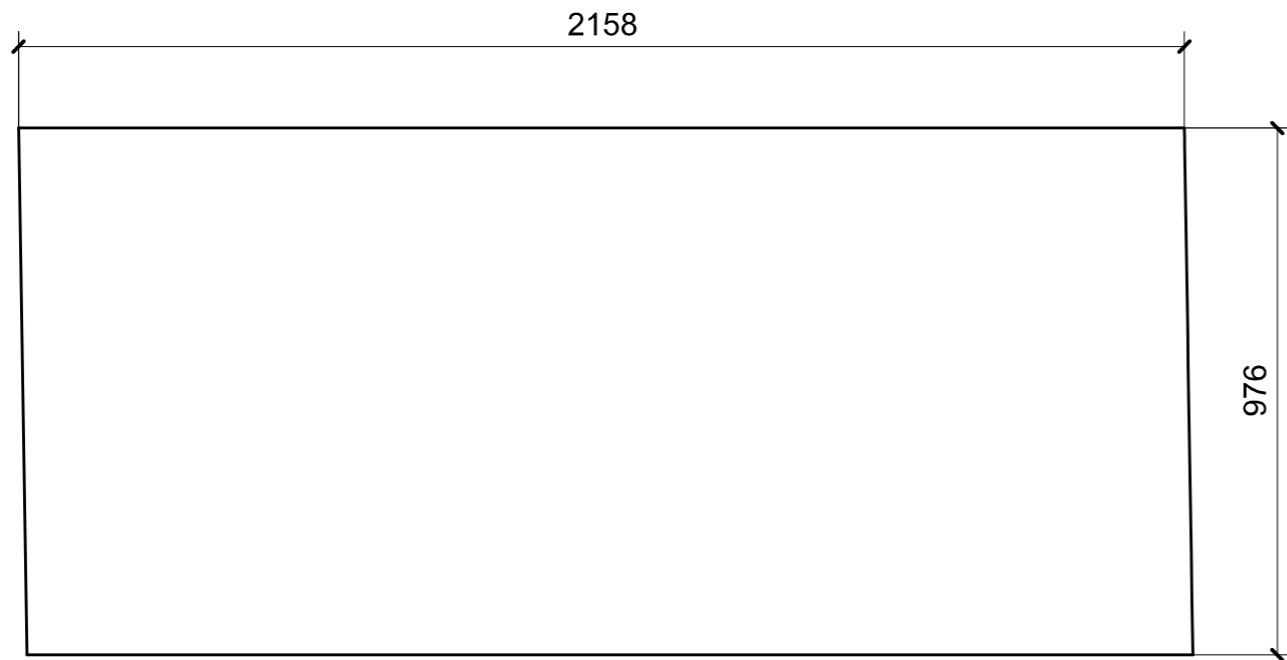

01

LOCALE	CODICE	DESCRIZIONE COMPONENTE	FINITURA	Q.TA
BAGNO OSPITI DX	MD299_I01_ZQ01	PANNELLO OBLO'	OKUME' GREZZO	1

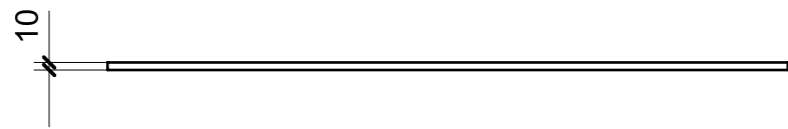
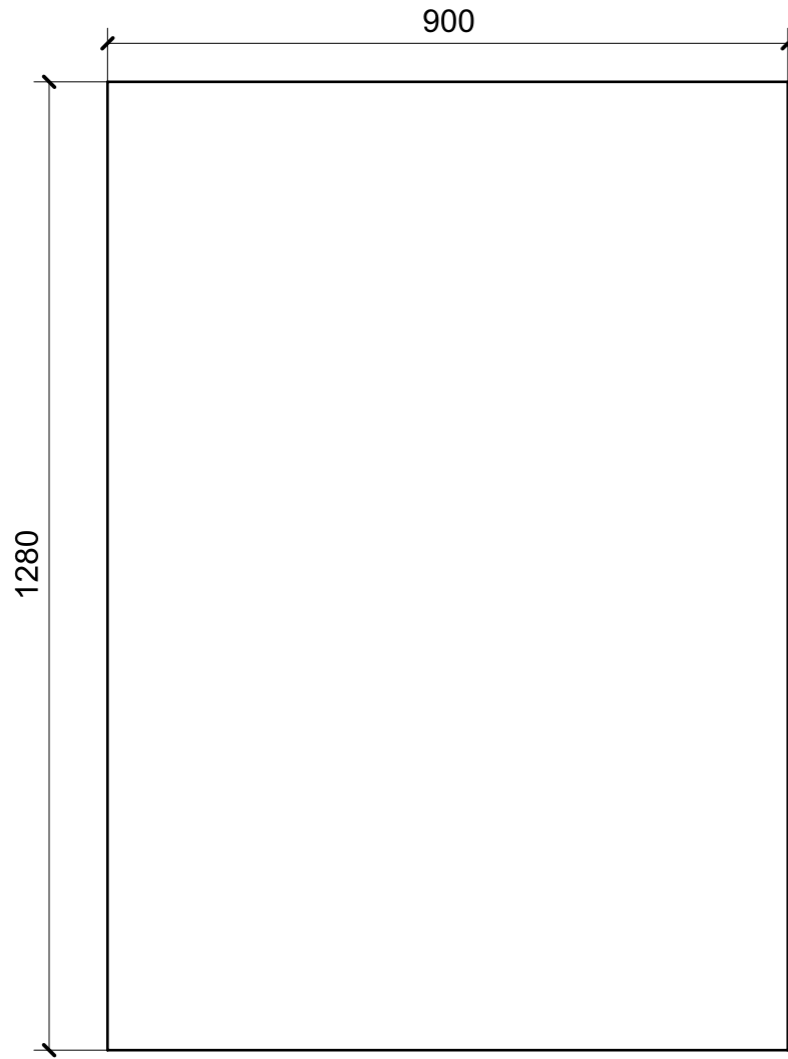

01

LOCALE	CODICE	DESCRIZIONE COMPONENTE	FINITURA	Q.TA
CABINA OSPITI SX	MD299_I01_LB01	PENSILE	OKUME' GREZZO	1

01

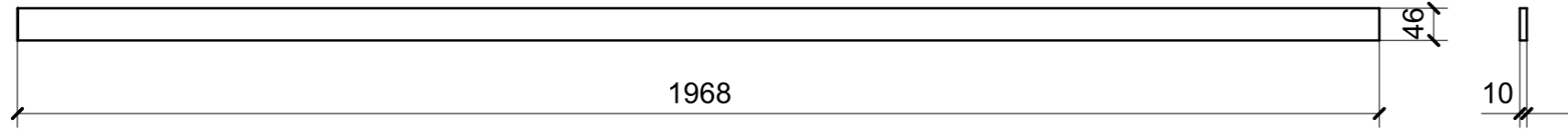

02

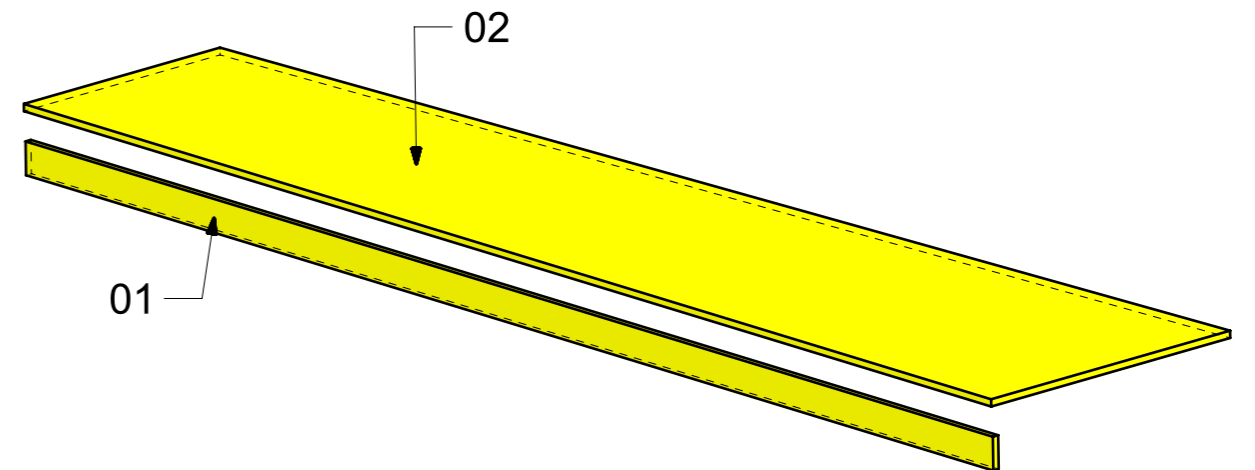
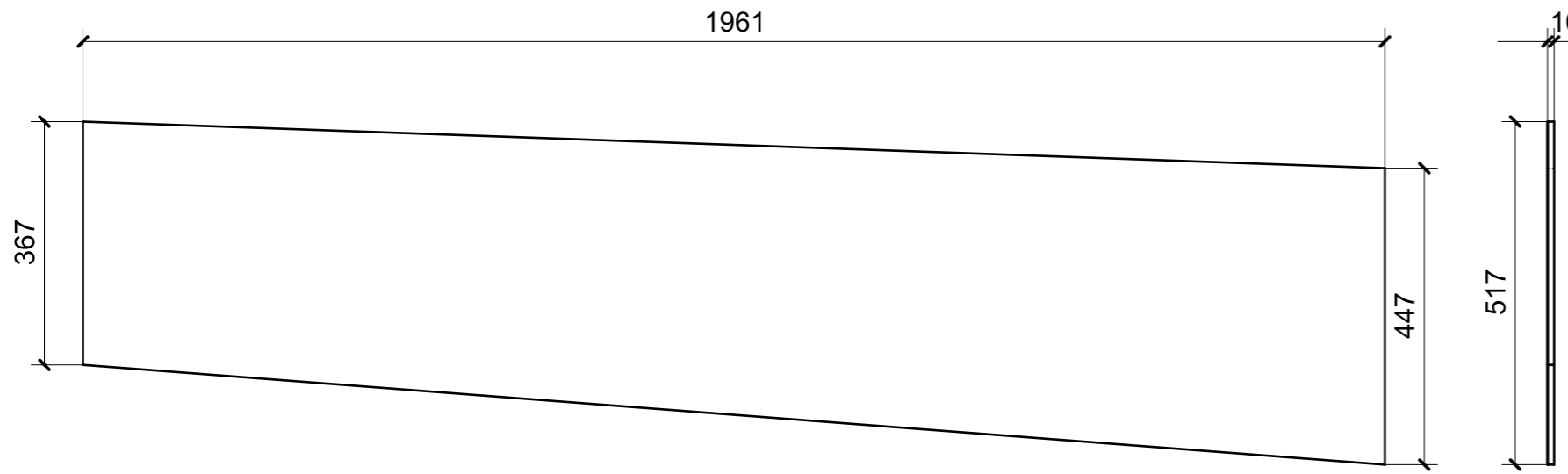

LOCALE	CODICE	DESCRIZIONE COMPONENTE	FINITURA	Q.TA
CABINA OSPITI SX	MD299_I01_LC01	STRUTTURA TESTALETTO	OKUME' GREZZO	1

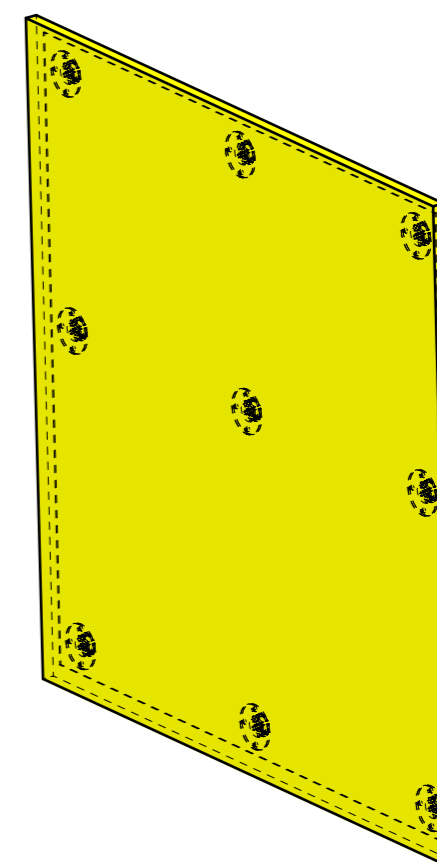
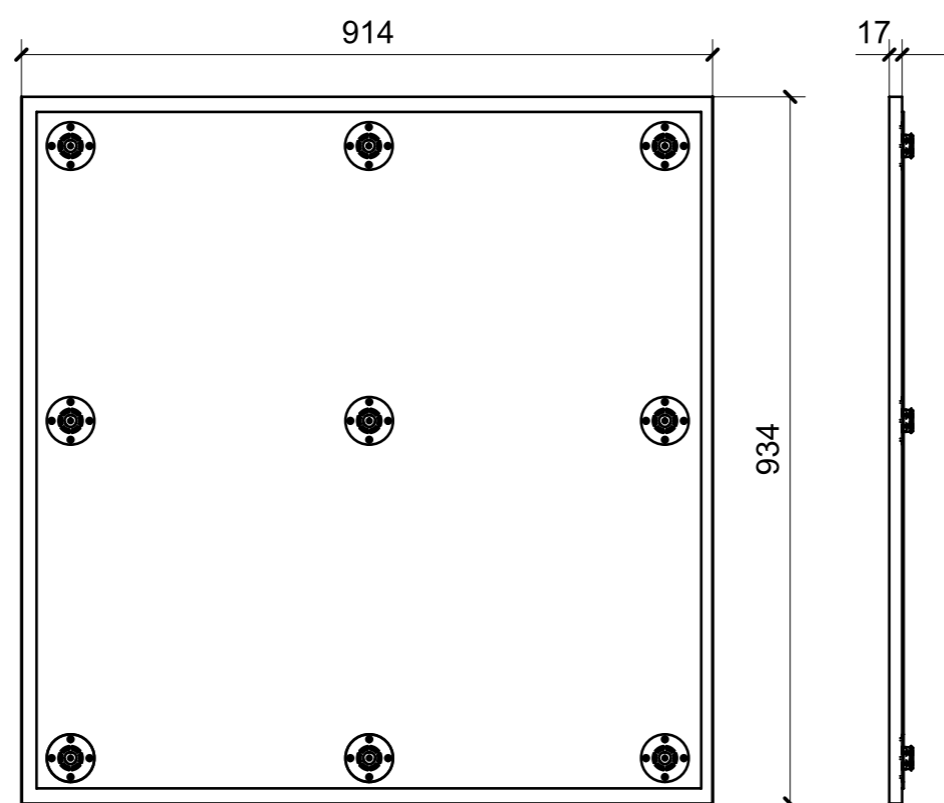

FERRAMENTA	QTY
FITLOCK M_MASCHERPA_3MM_6020202101	9

LOCALE	CODICE	DESCRIZIONE COMPONENTE	FINITURA	Q.TA
CABINA OSPITI SX	MD299_I01_LD01	COLLEGAMENTO BASSO	OKUME' GREZZO	1

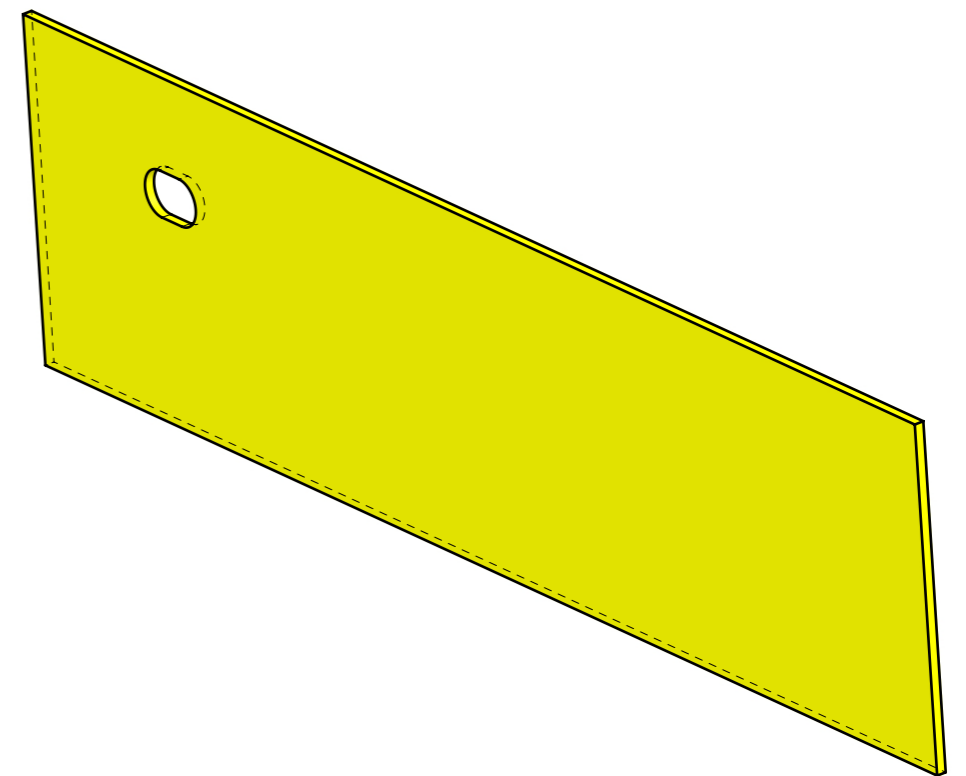
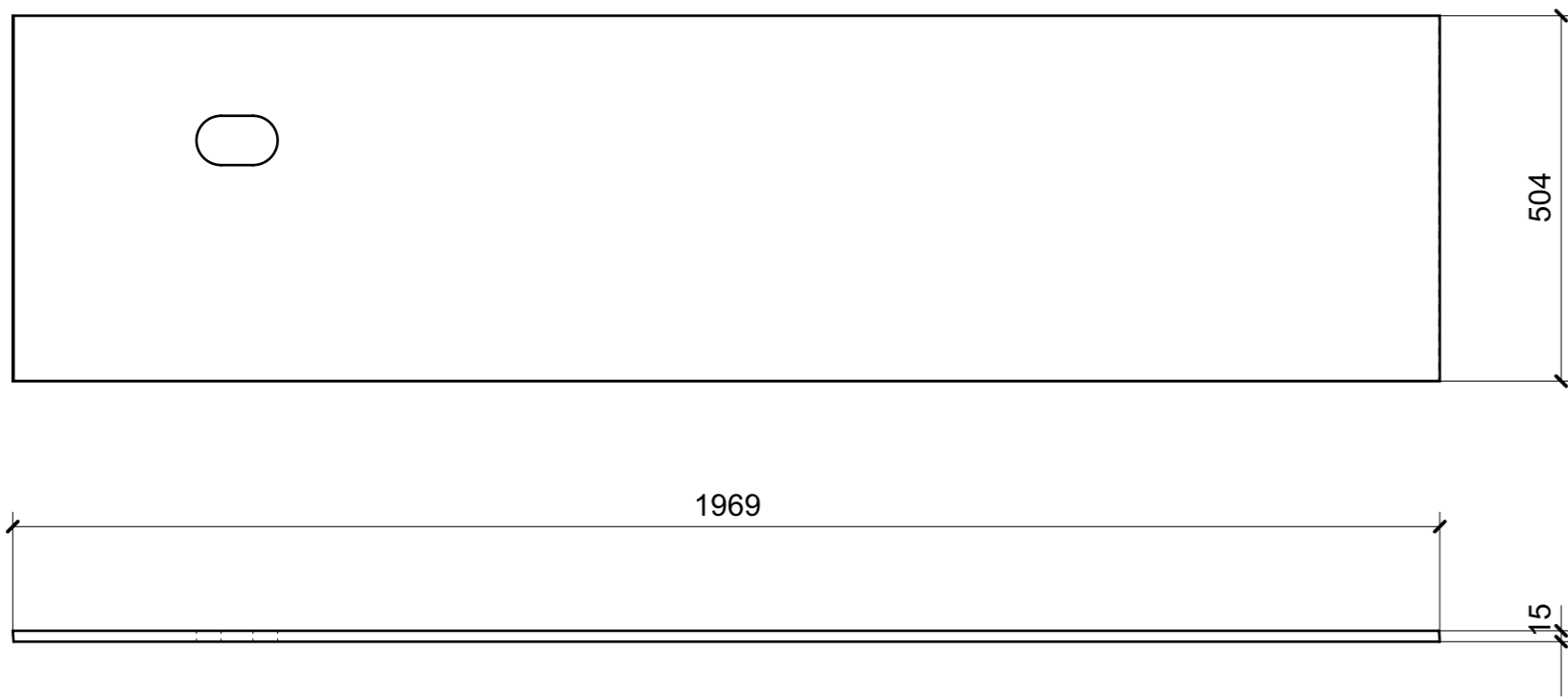

LOCALE	CODICE	DESCRIZIONE COMPONENTE	FINITURA	Q.TA
CABINA OSPITI SX	MD299_I01_LE01	STRUTTURA LETTO_STD-VAR 1	OKOUME' GREZZO	1

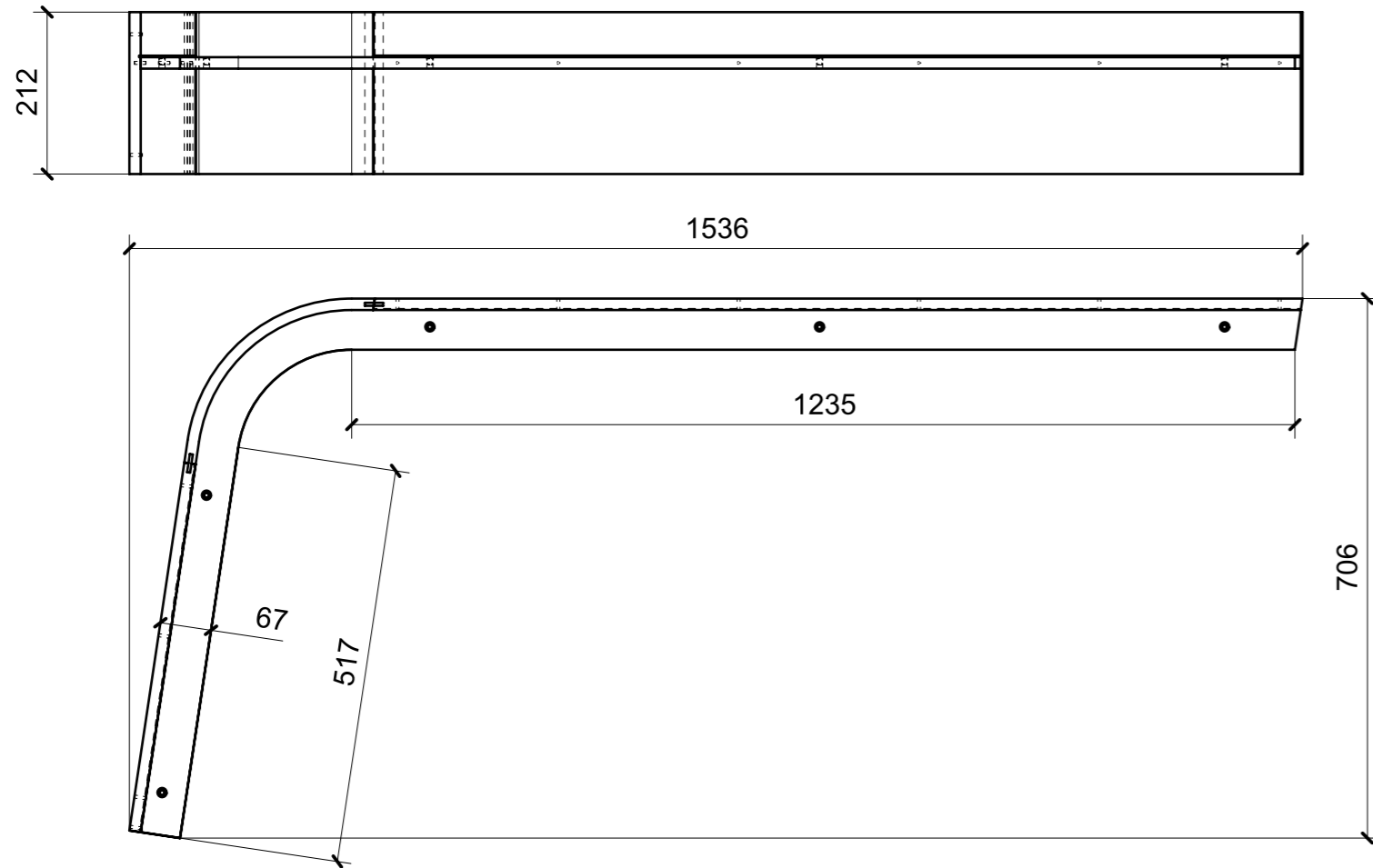

01

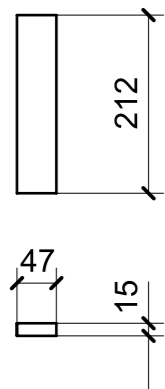
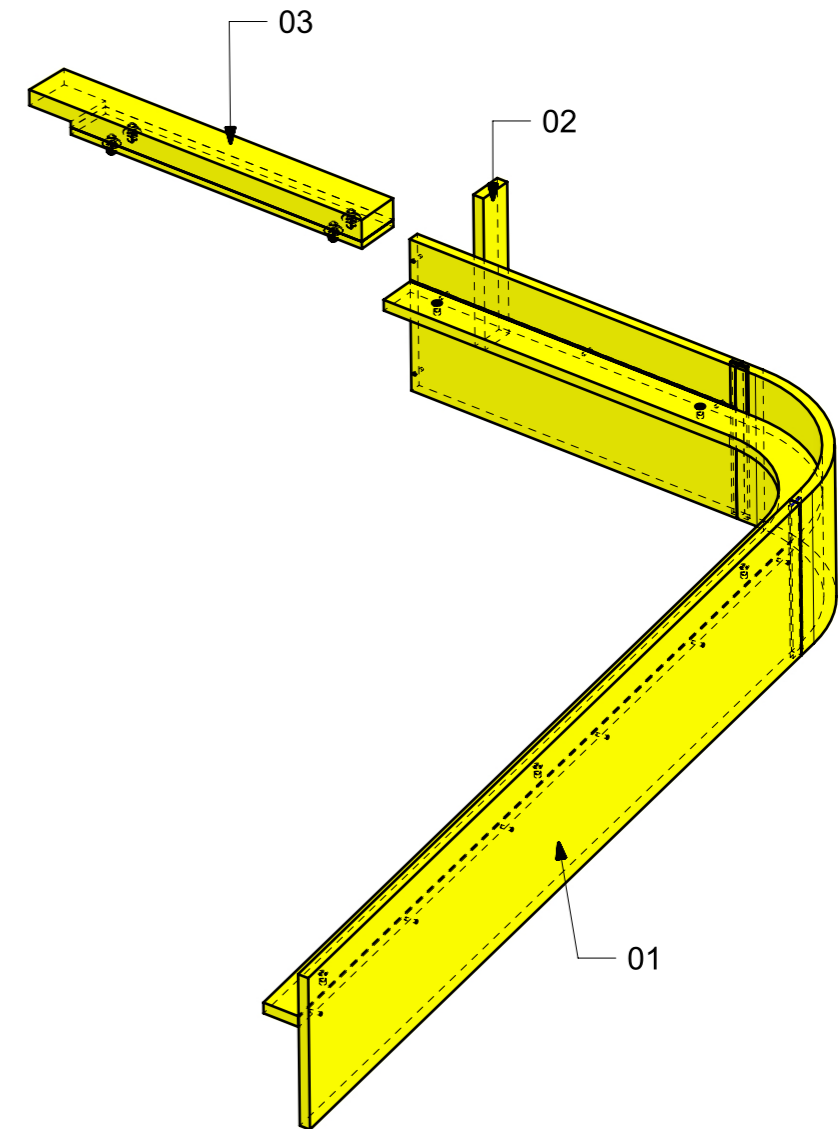

02

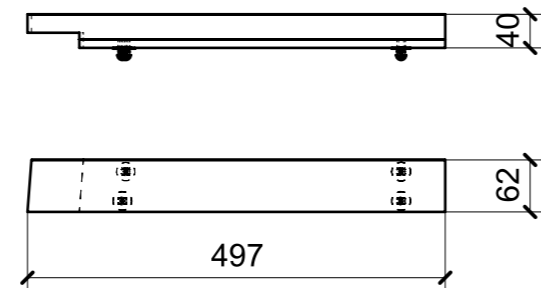

03

FERRAMENTA	QTY
MS INCASSO_ITALVIPLA_972_FMPC_M1B	4
BUSSOLA 6MA X 10 FORO DIAM.8	5

LOCALE	CODICE	DESCRIZIONE COMPONENTE	FINITURA	Q.TA
CABINA OSPITI SX	MD299_I01_LF01	COMODINO_ STD VAR 1	OKUME' GREZZO	1

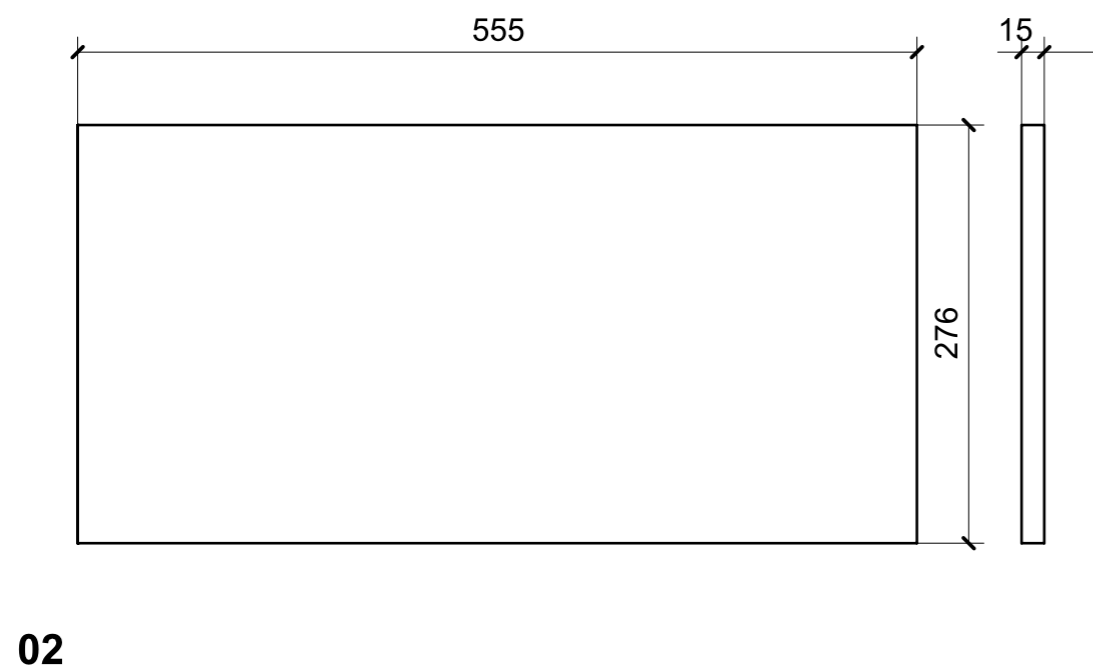
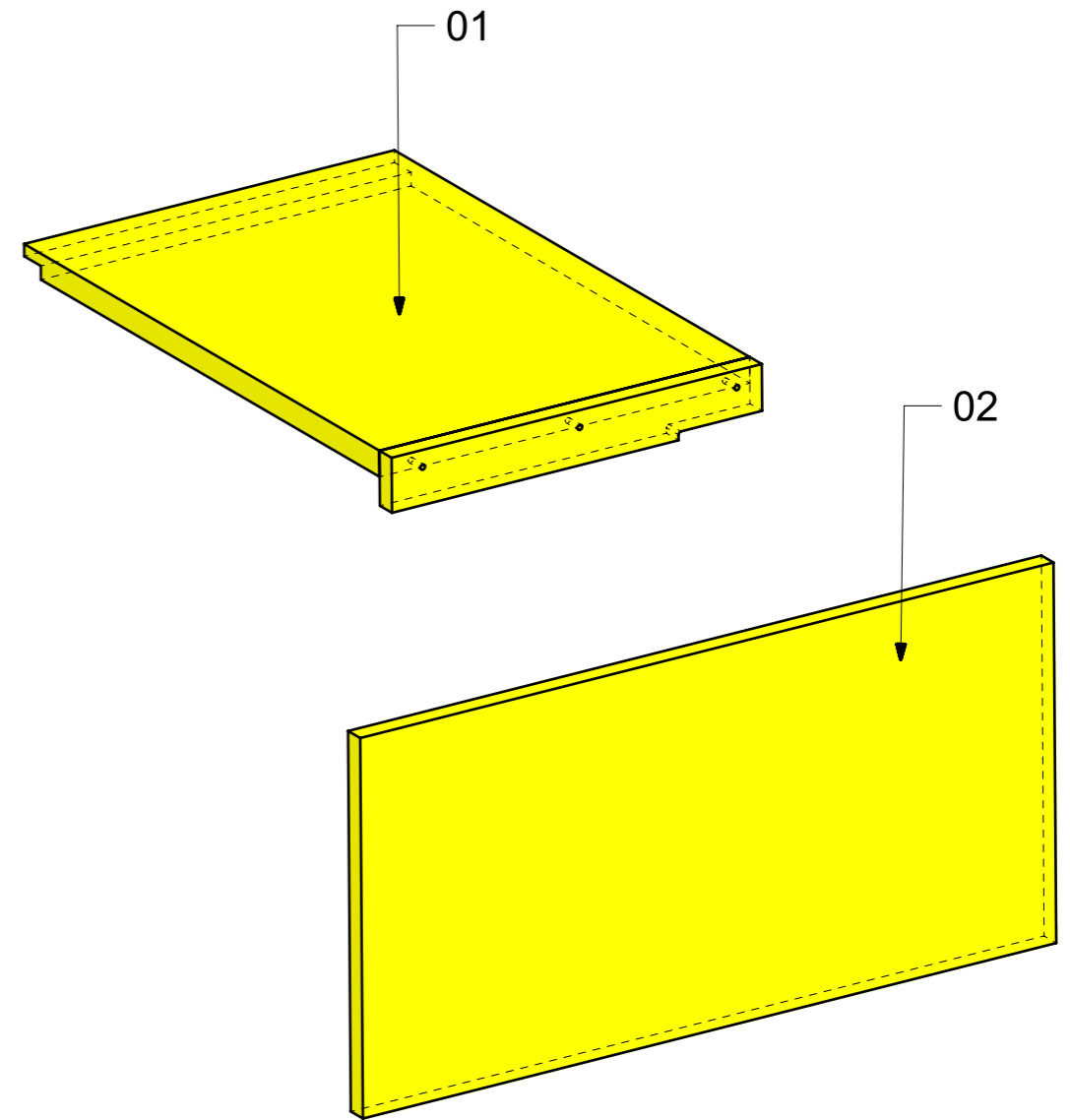
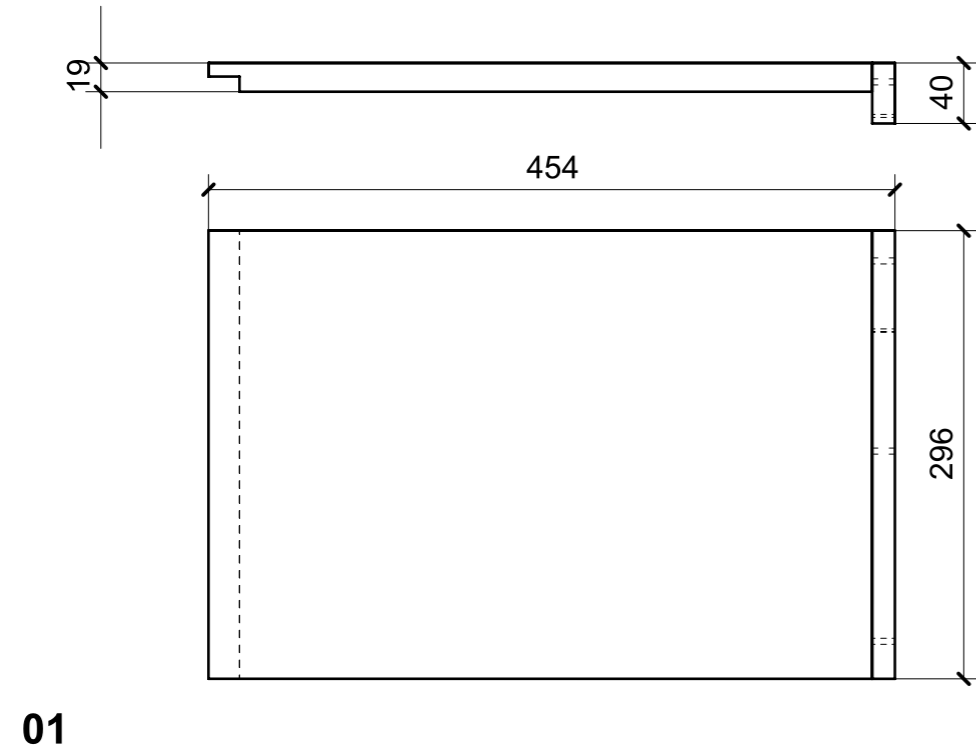

LOCALE	CODICE	DESCRIZIONE COMPONENTE	FINITURA	Q.TA
CABINA OSPITI SX	MD299_I01_LI01	TESTALETTO DOPPIO_STD VAR 2	OKUME' GREZZO	1

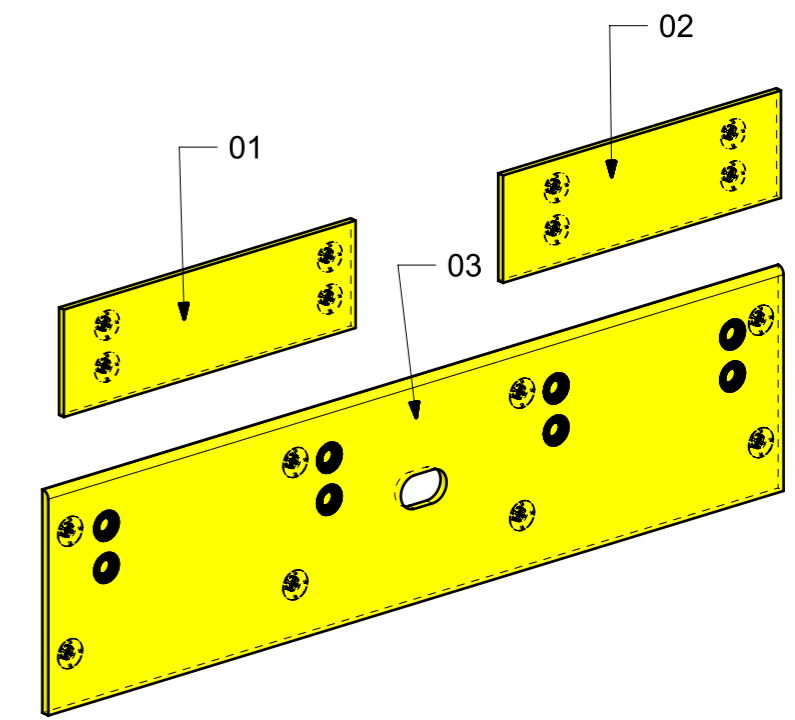
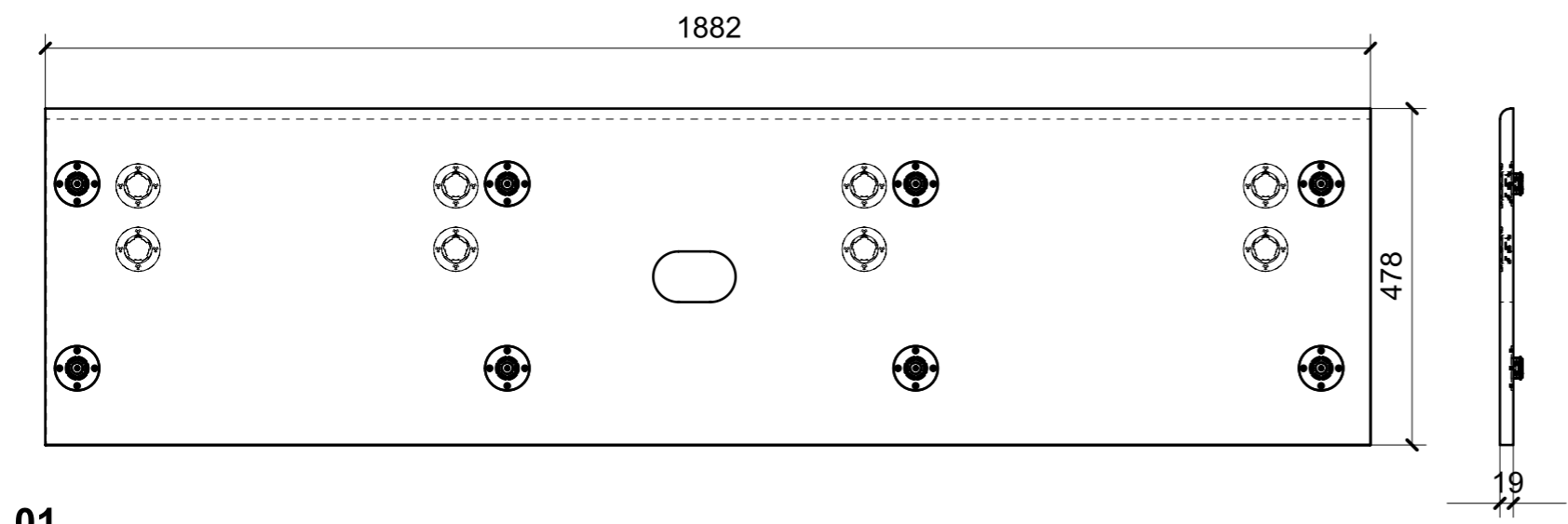

FERRAMENTA	QTY
FITLOCK F_MASCHERPA_6020101102	8
FITLOCK M_MASCHERPA_3MM_6020202101	16

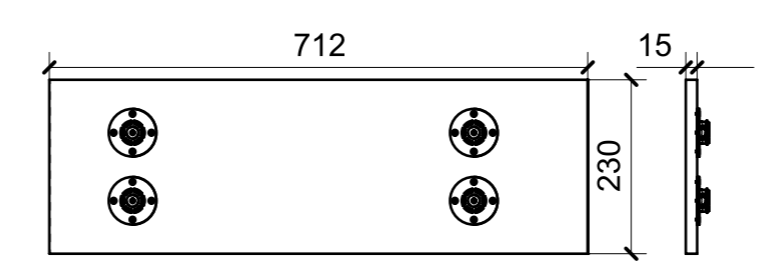
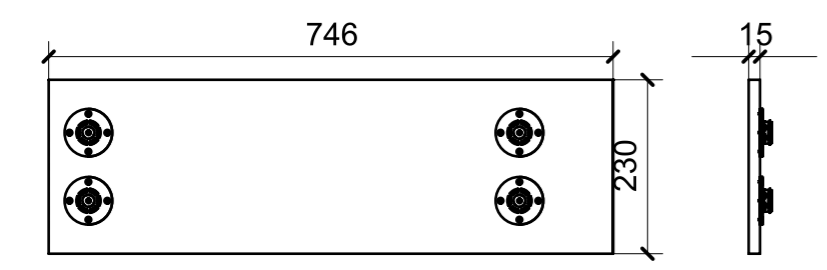

LOCALE	CODICE	DESCRIZIONE COMPONENTE	FINITURA	Q.TA
CABINA OSPITI SX	MD299_I01_LH01	COPERTURA FINESTRATURA	OKUME' GREZZO	1

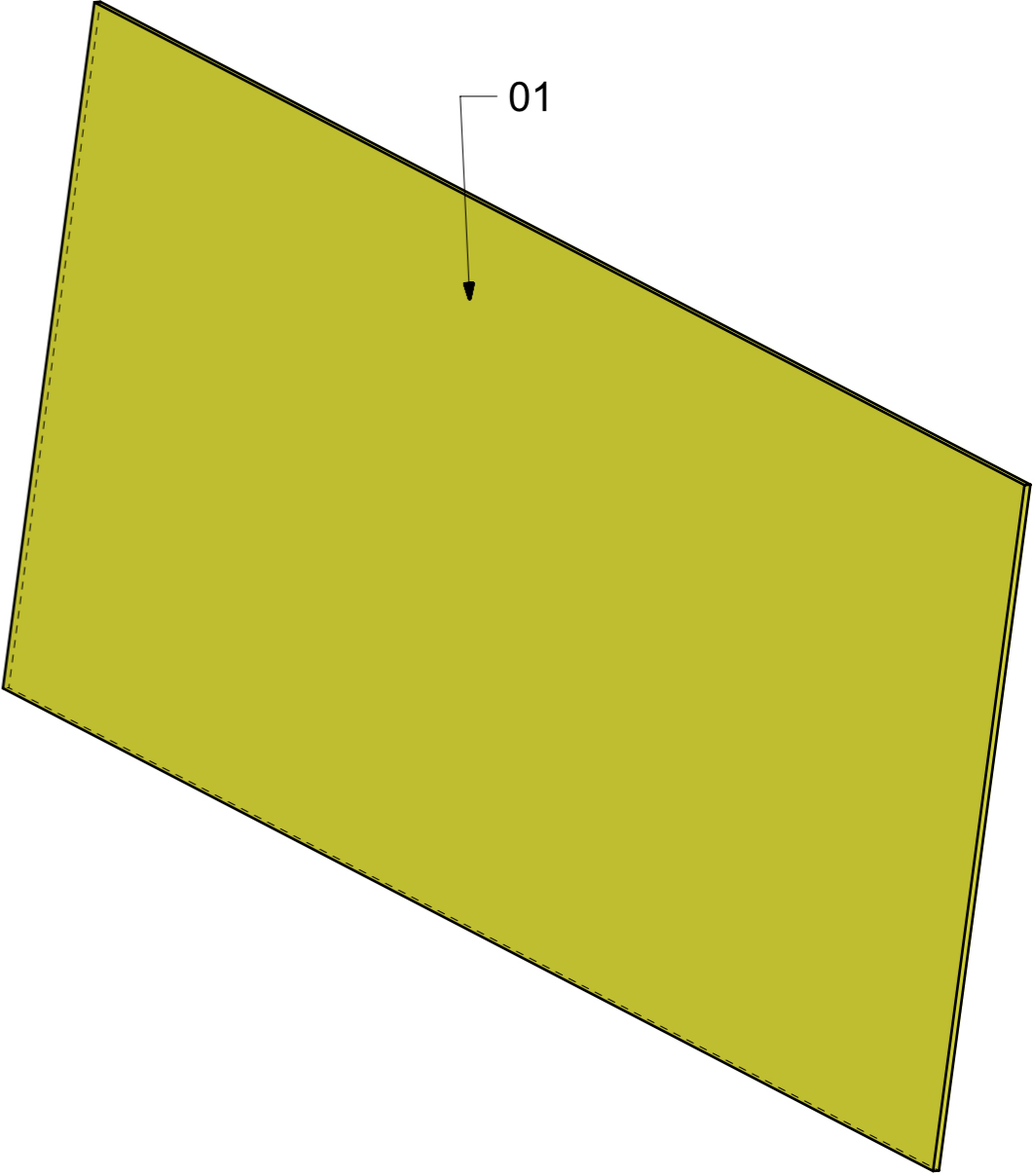

01

LOCALE	CODICE	DESCRIZIONE COMPONENTE	FINITURA	Q.TA
CABINA OSPITI SX	MD299_I01_LL01	RIVESTIMENTI PARATIA LUNGONAVE	OKUME' GREZZO	1

01

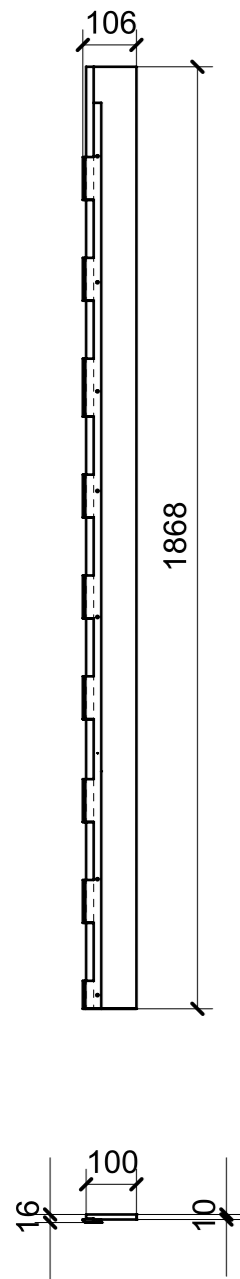

02

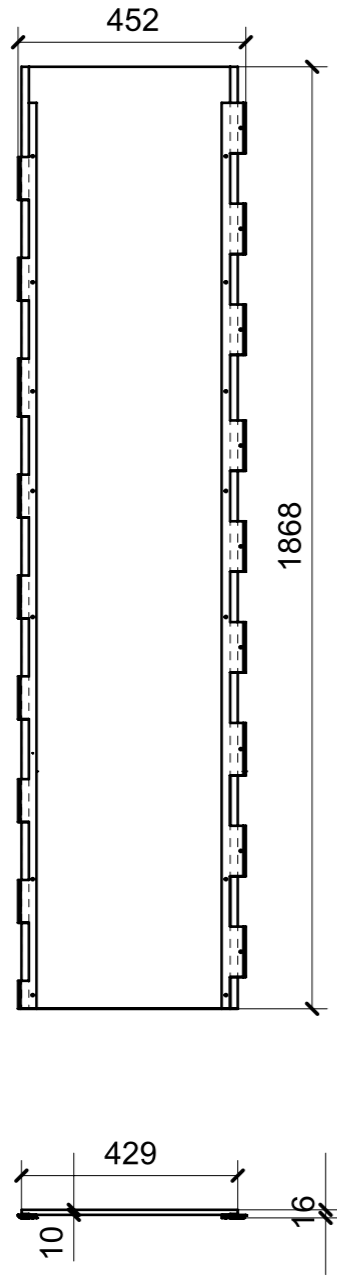

03

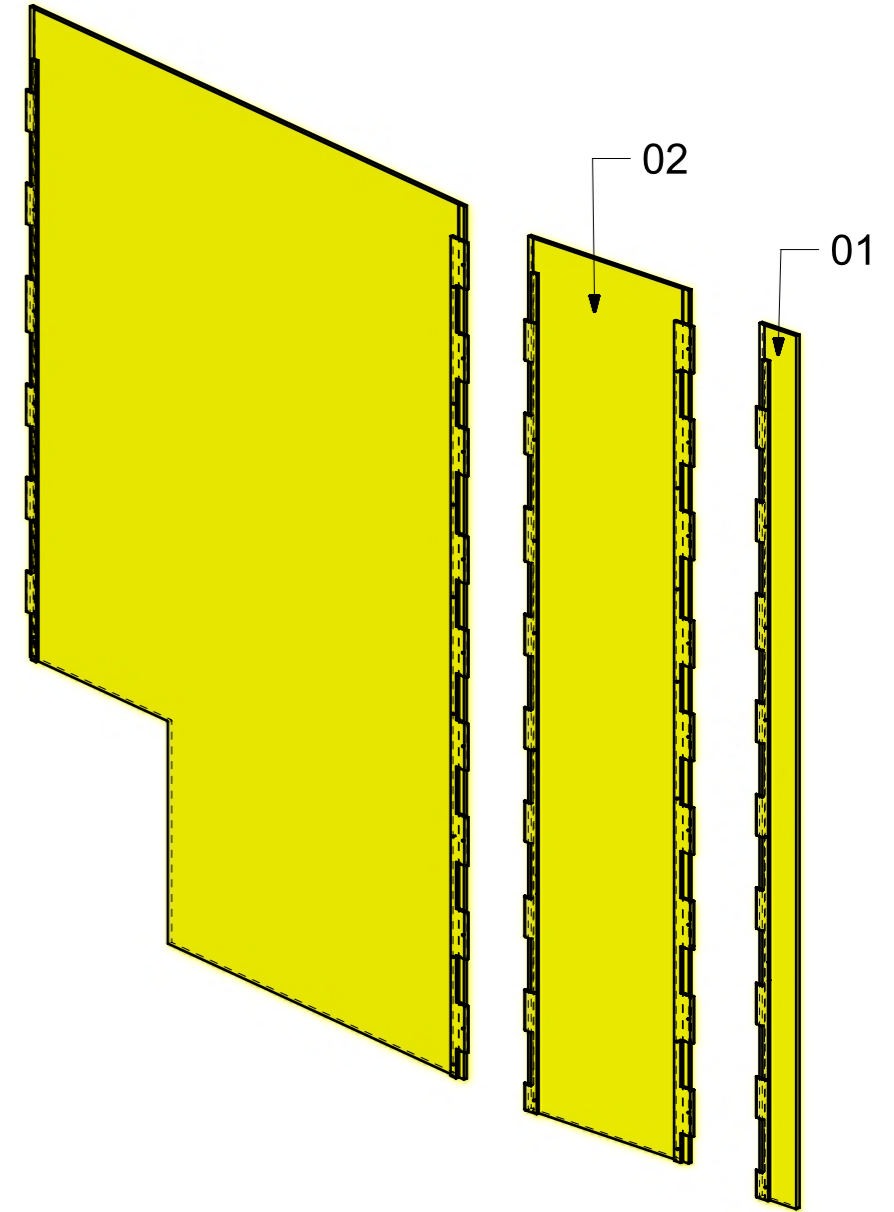
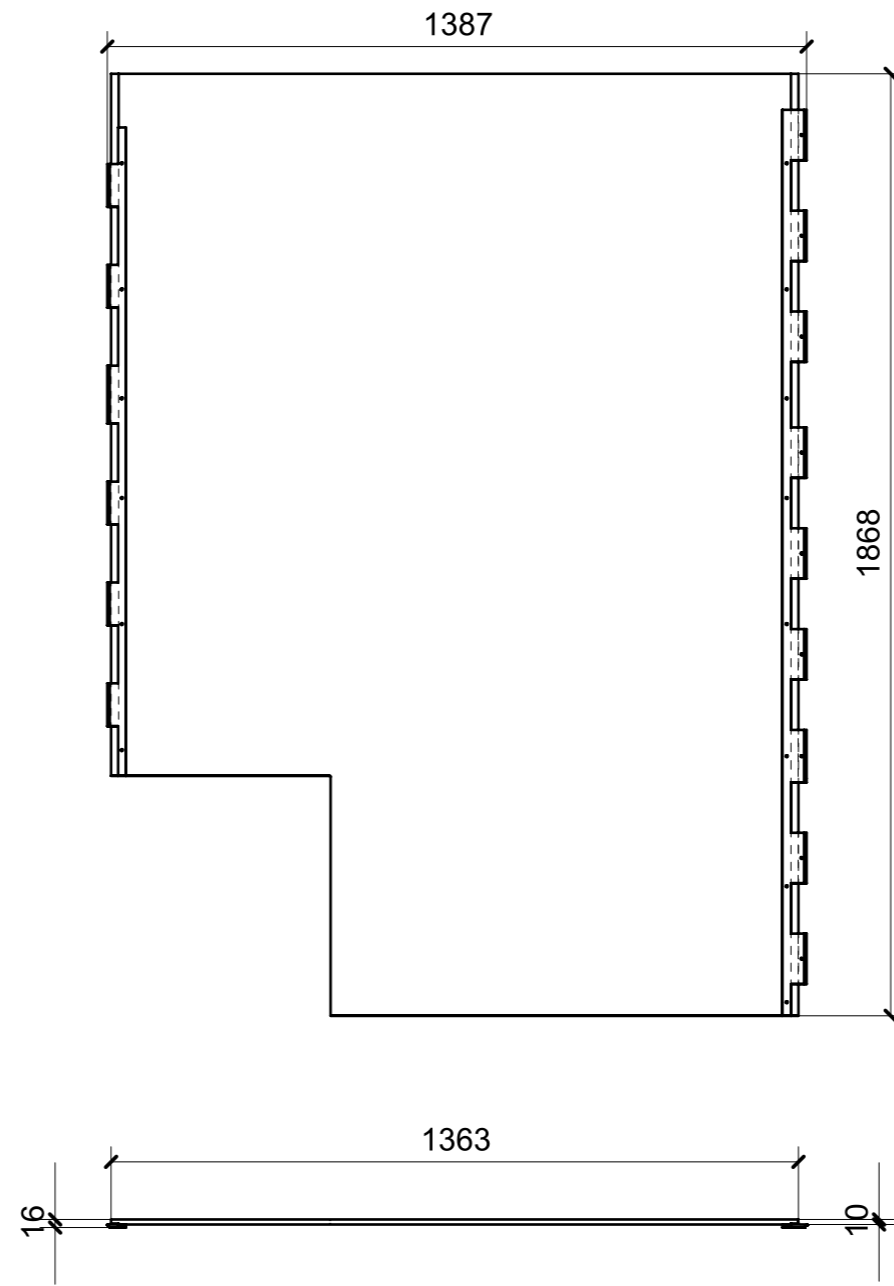

LOCALE	CODICE	DESCRIZIONE COMPONENTE	FINITURA	Q.TA
CABINA OSPITI SX	MD299_I01_LN01	TESTALETTO_STD VAR 1	OKUME' GREZZO	1

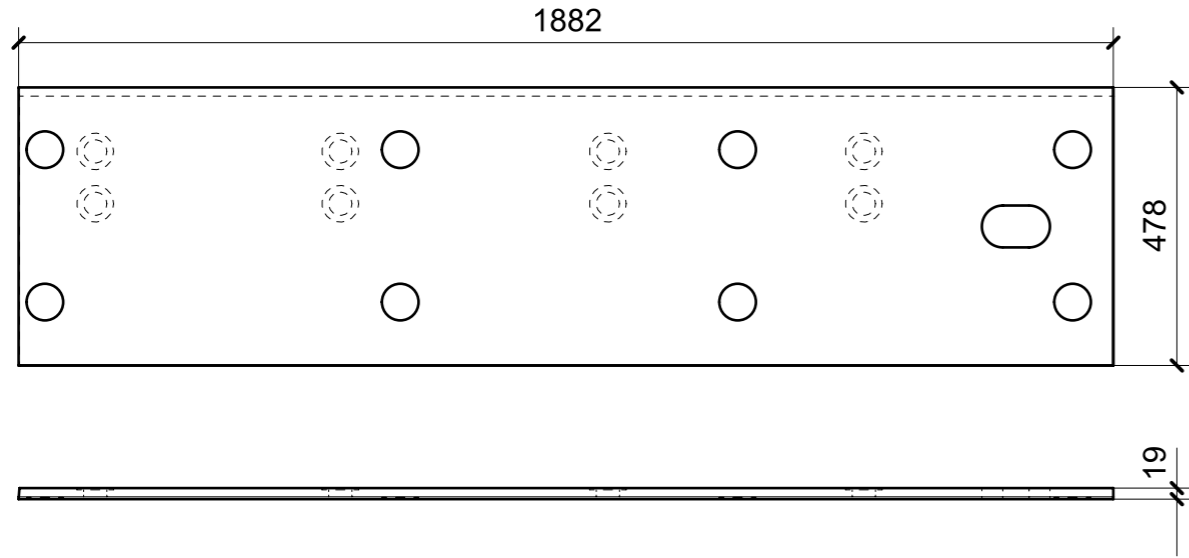

01

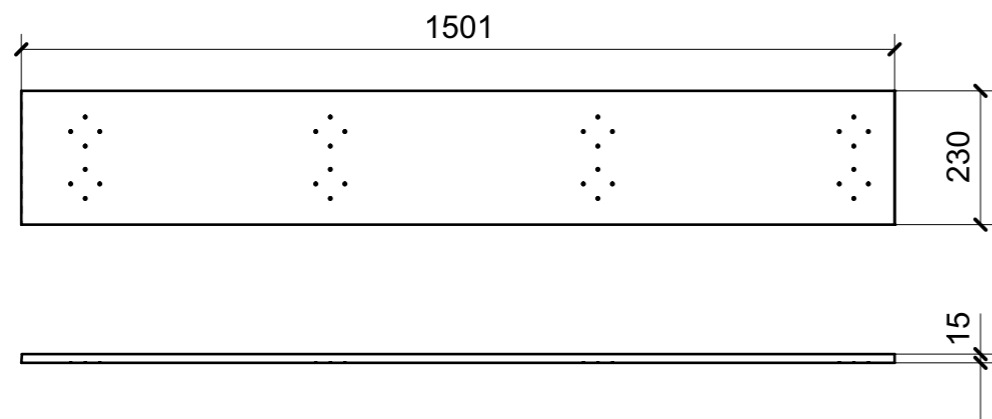
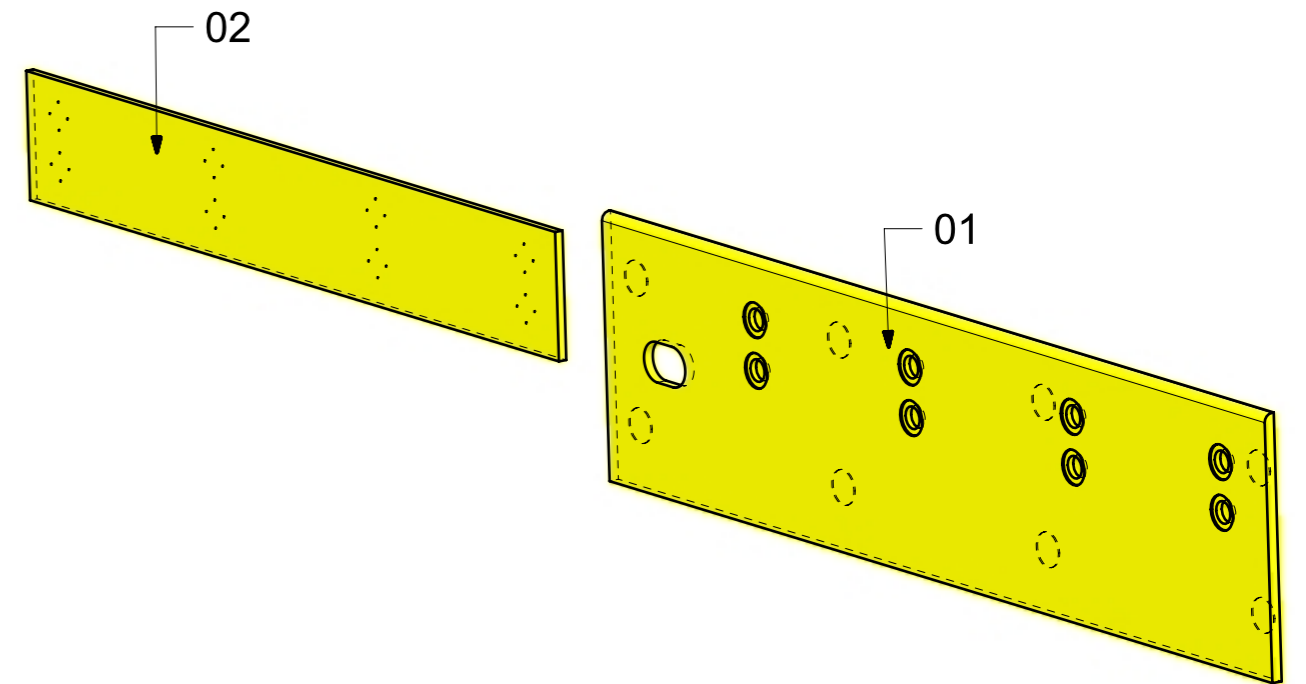

02

FERRAMENTA	QTY
FITLOCK F_MASCHERPA_6020101102	8
FITLOCK M_MASCHERPA_3MM_6020202101	16

LOCALE	CODICE	DESCRIZIONE COMPONENTE	FINITURA	Q.TA
CABINA OSPITI SX	MD299_I01_LO01	LETTO MURATA_STD VAR 2	OKUME' GREZZO	1

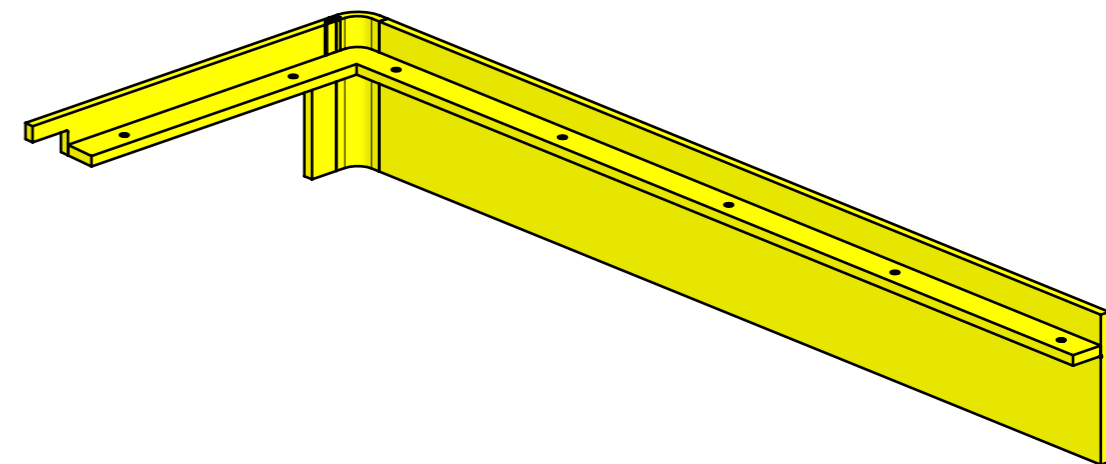
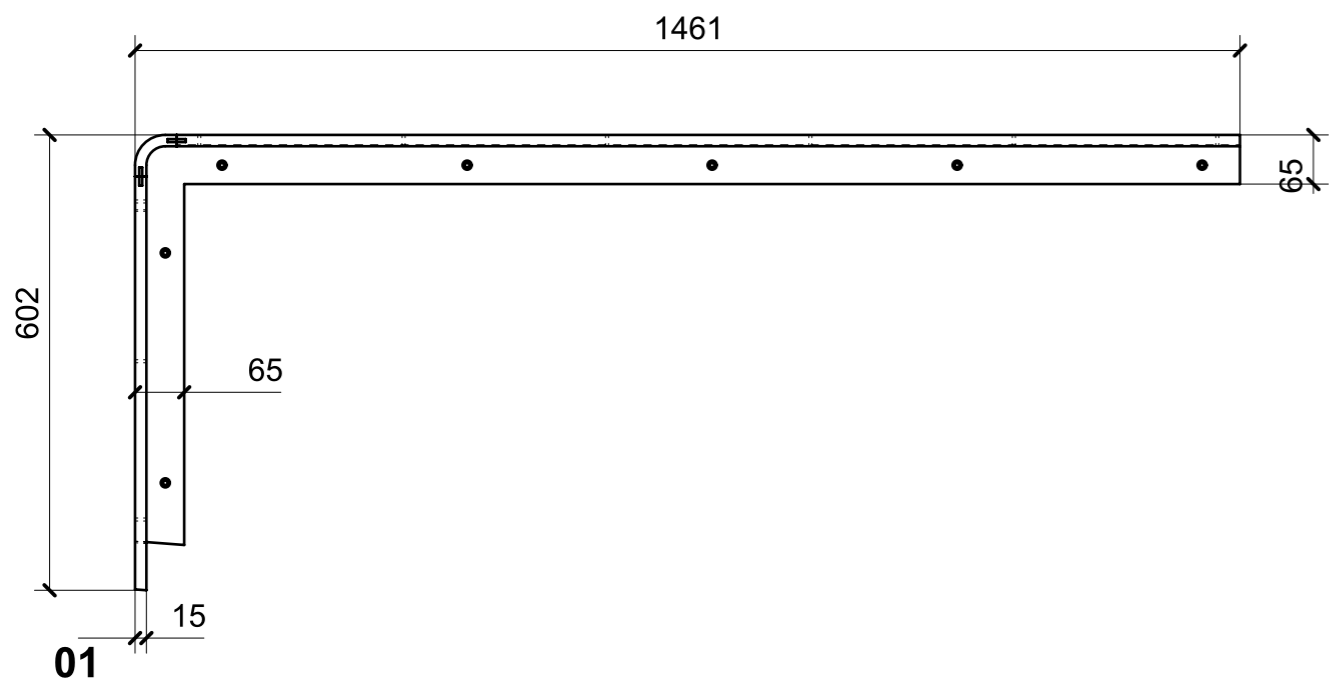
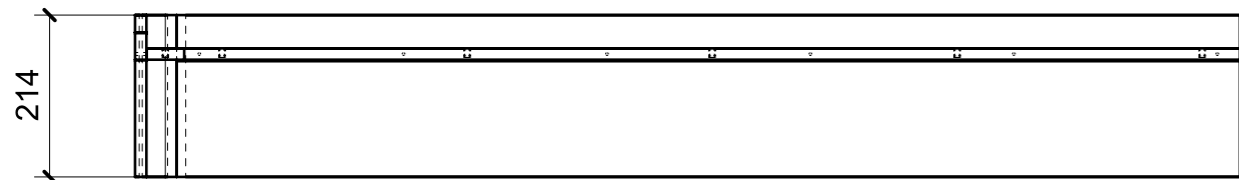

FERRAMENTA	QTY
BUSSOLA 6MA X 10 FORO DIAM.8	7

LOCALE	CODICE	DESCRIZIONE COMPONENTE	FINITURA	Q.TA
CABINA OSPITI SX	MD299_I01_LP01	LETTO CENTROBARCA_STD VAR 2	OKUME' GREZZO	1

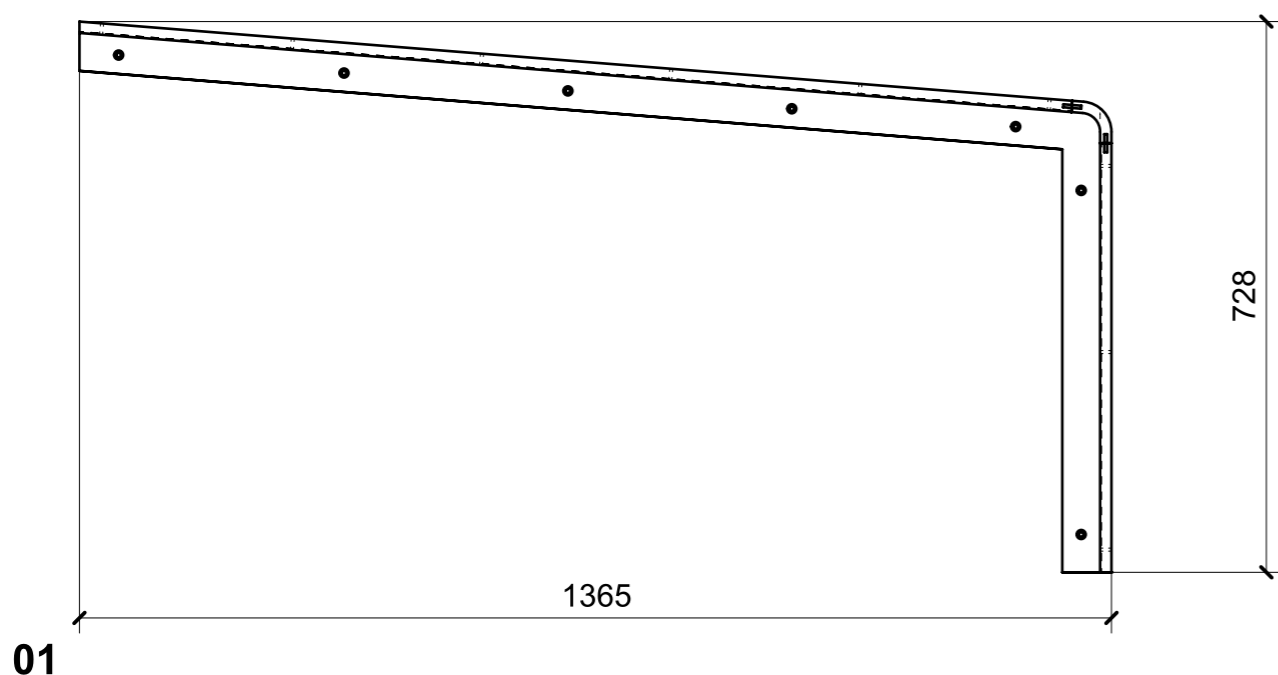
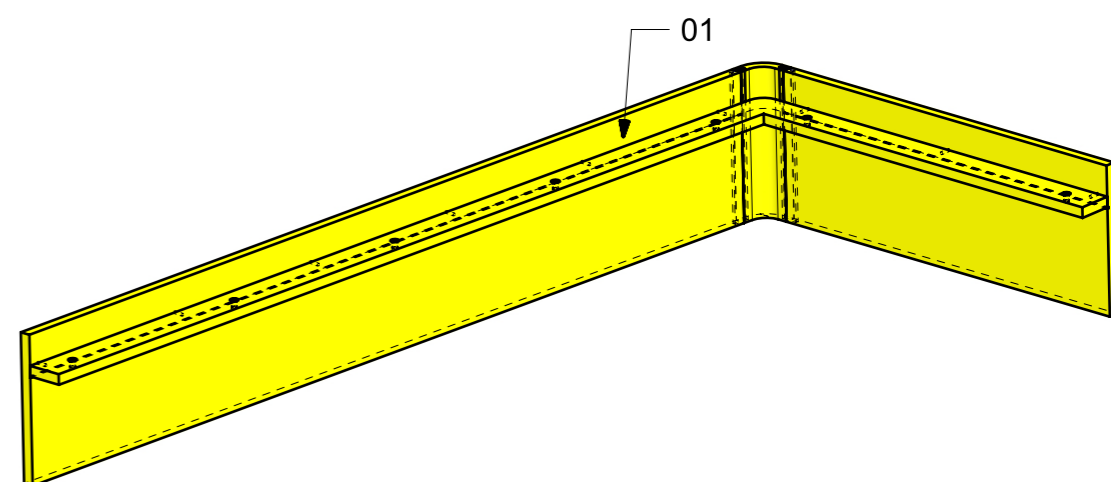
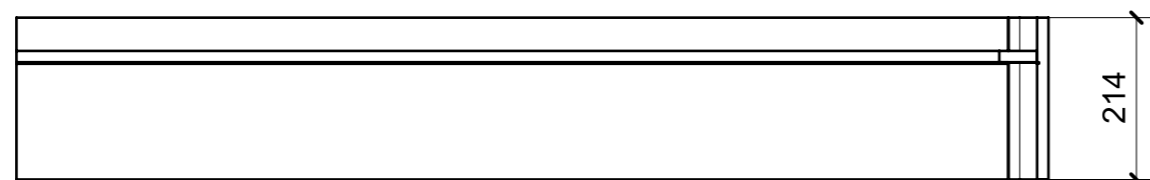

FERRAMENTA	QTY
BUSSOLA 6MA X 10 FORO DIAM.8	7

LOCALE	CODICE	DESCRIZIONE COMPONENTE	FINITURA	Q.TA
CABINA OSPITI SX	MD299_I01_LQ01	COMODINO_STD VAR 2	OKUME' GREZZO	1

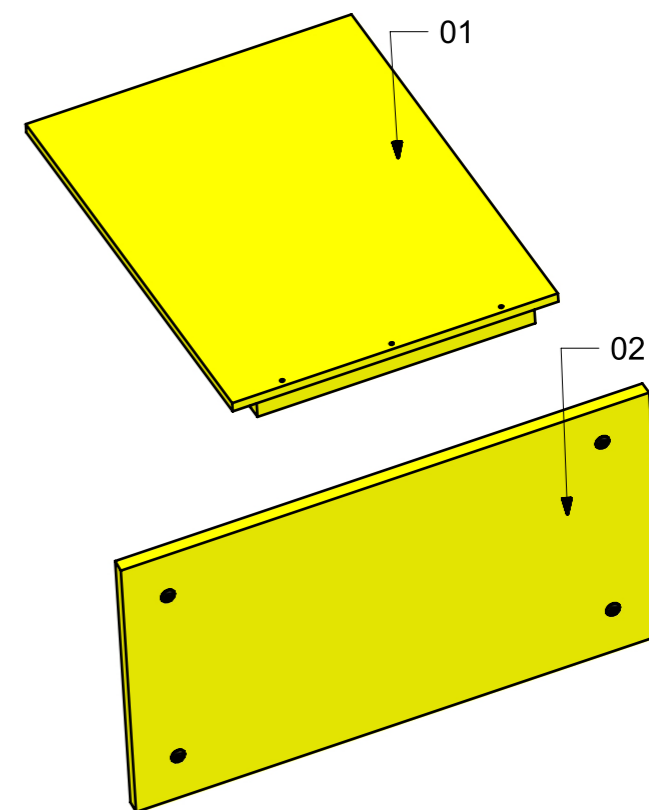
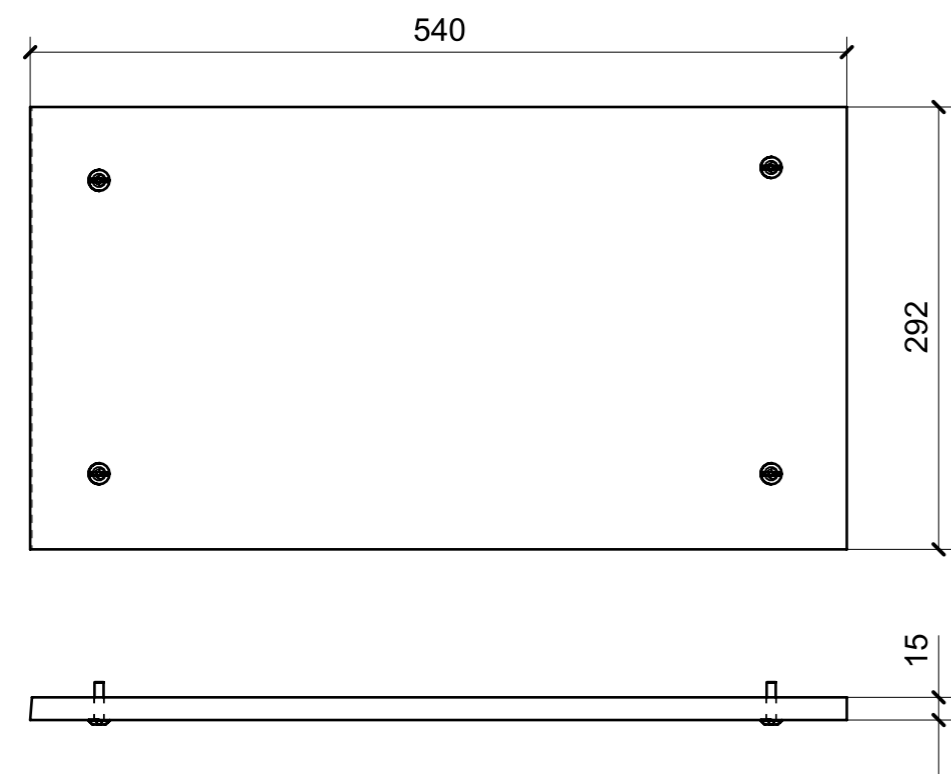
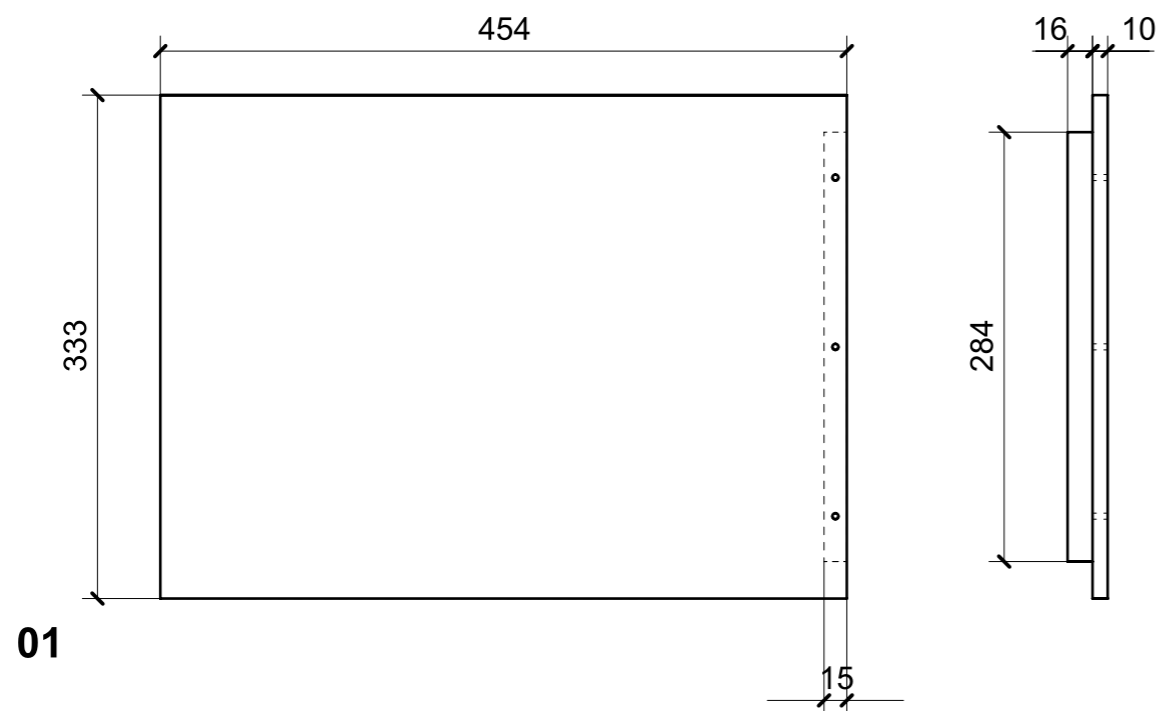

FERRAMENTA	QTY
VITE 6MA X 25 TESTA BOMBATA	4

LOCALE	CODICE	DESCRIZIONE COMPONENTE	FINITURA	Q.TA
BAGNO OSPITI SX	MD299_I01_YR01	PANNELLO OBLO'	OKUME' GREZZO	1

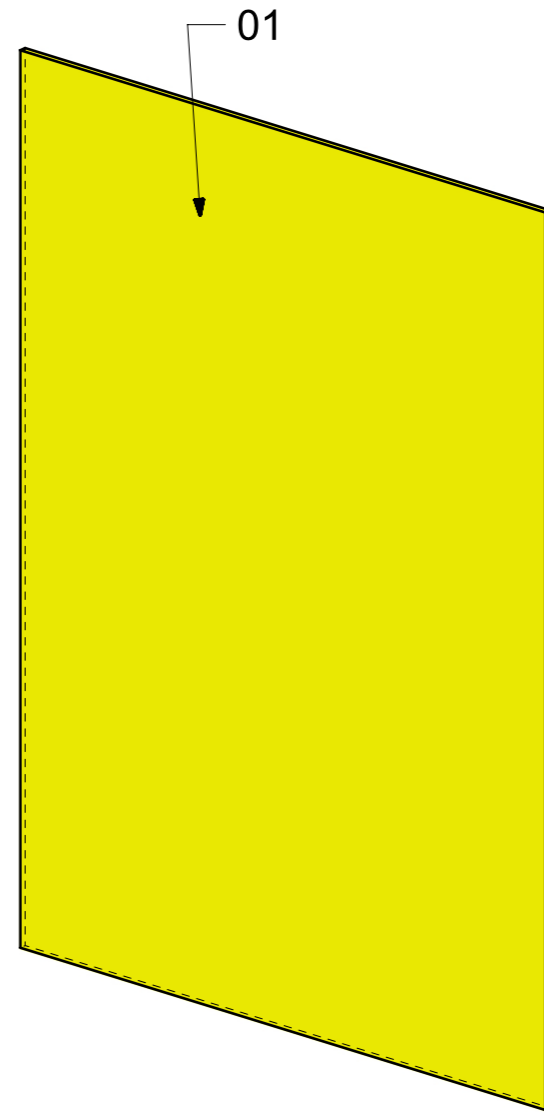
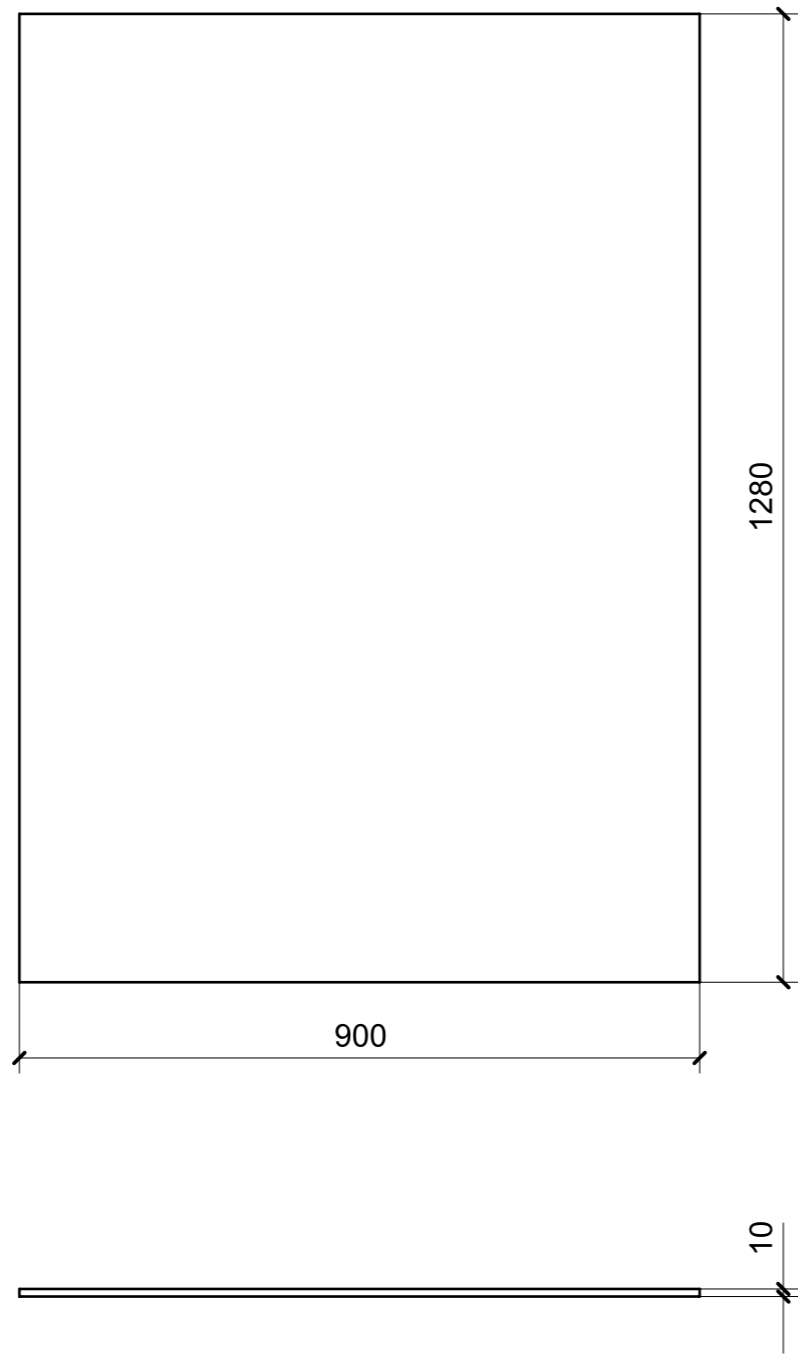

01

LOCALE	CODICE	DESCRIZIONE COMPONENTE	FINITURA	Q.TA
LOBBY	MD299_I01_CB01	CIELINO GRIGLIA A.C.	OKUME' GREZZO	1

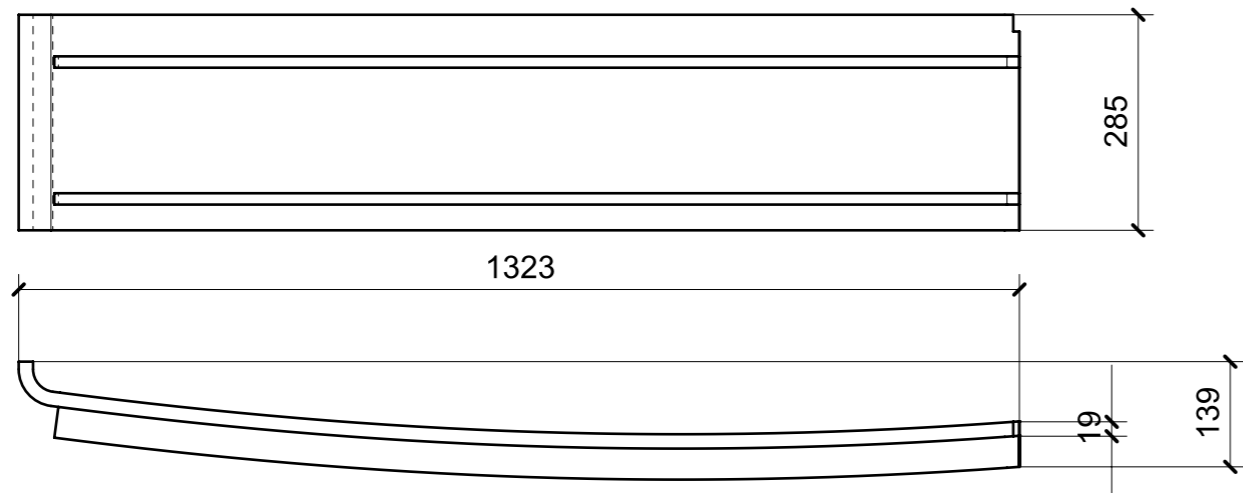

02

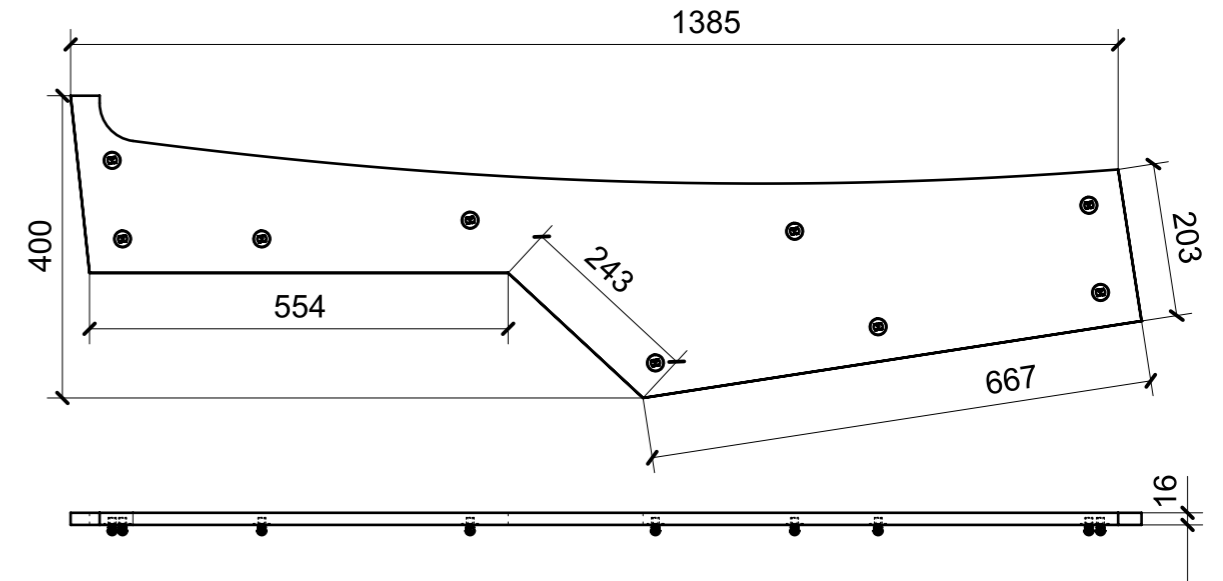

03

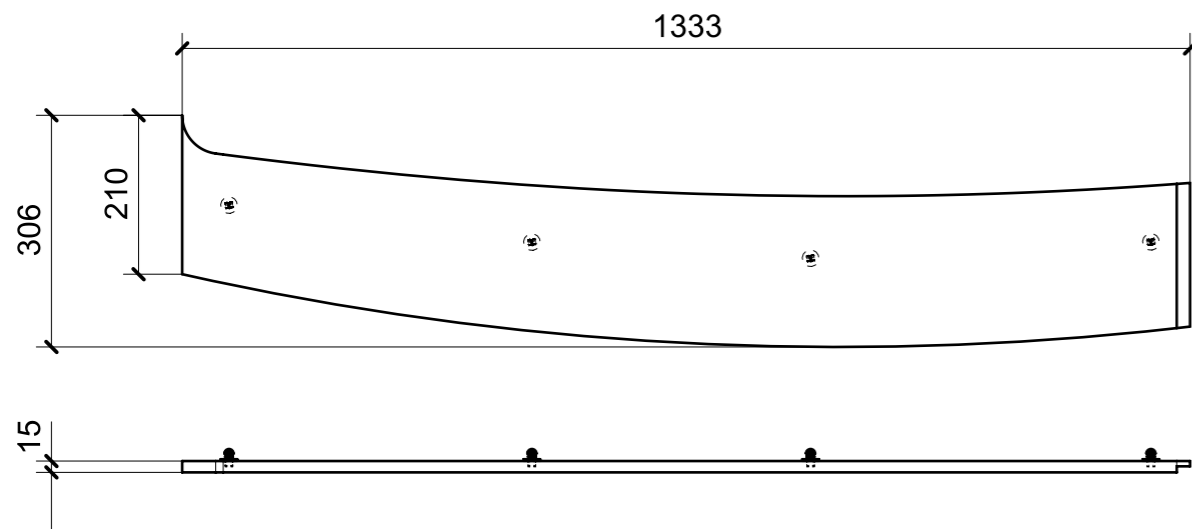

01

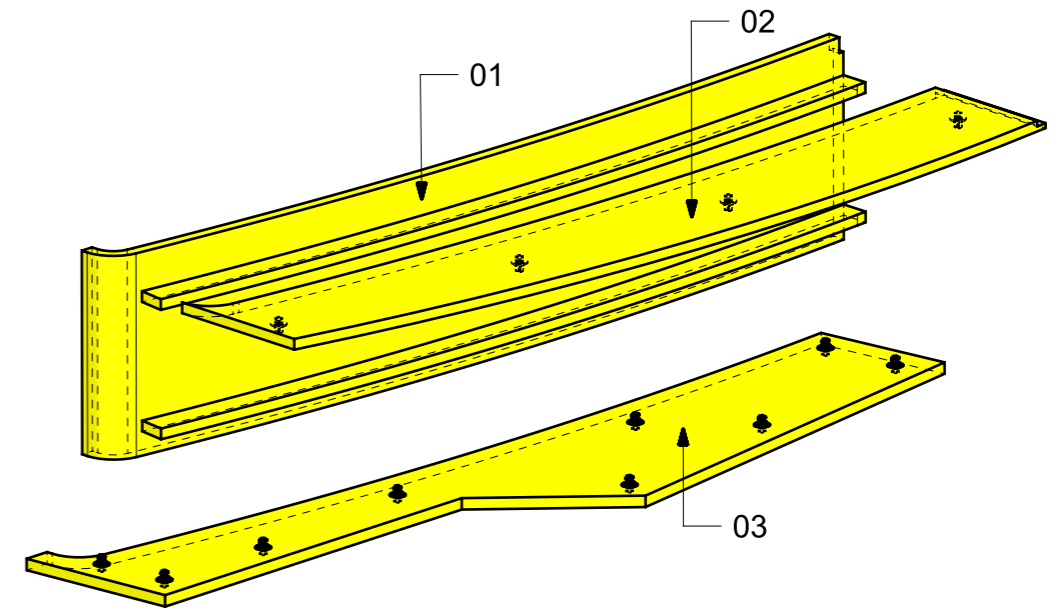

FERRAMENTA	QTY
MS INCASSO_ITALVIPLA_972_FMPC_M1B	13

LOCALE	CODICE	DESCRIZIONE COMPONENTE	FINITURA	Q.TA
LOBBY	MD299_I01_CC01	MURETTO SCALE	OKUME' GREZZO	1

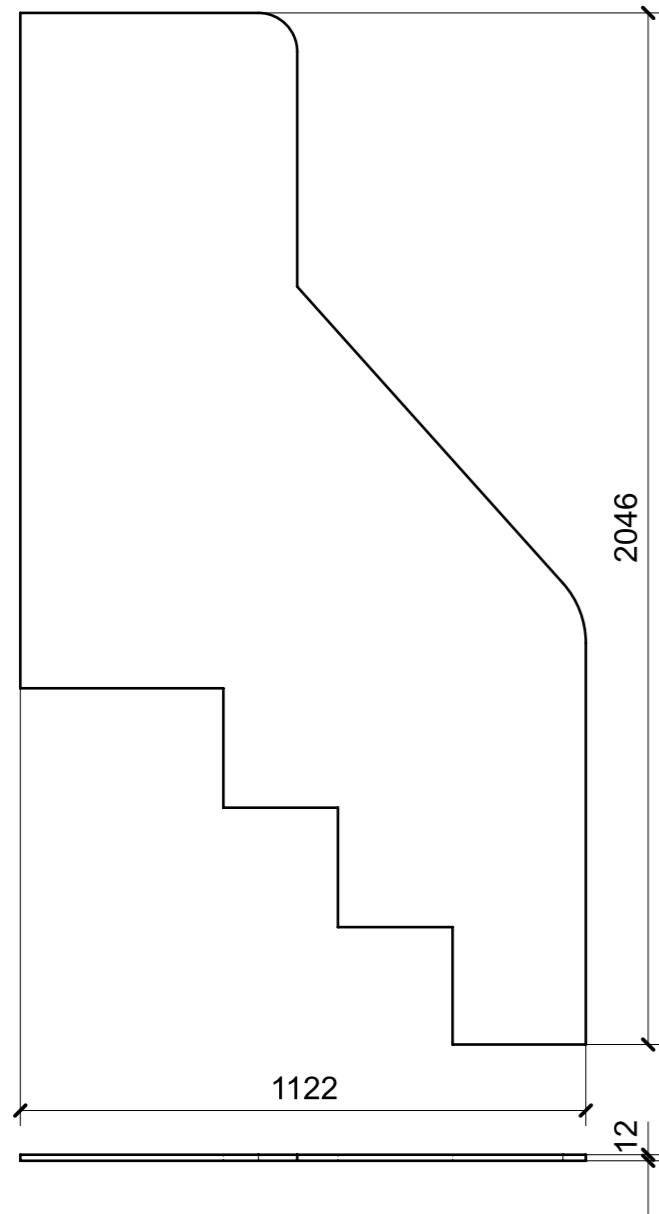

01

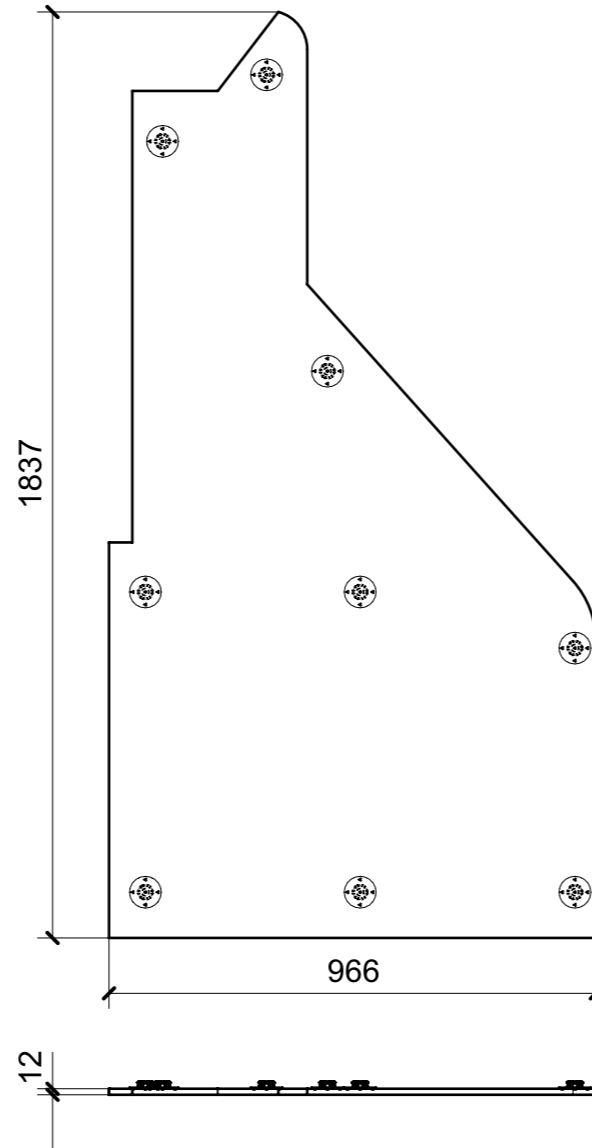

02

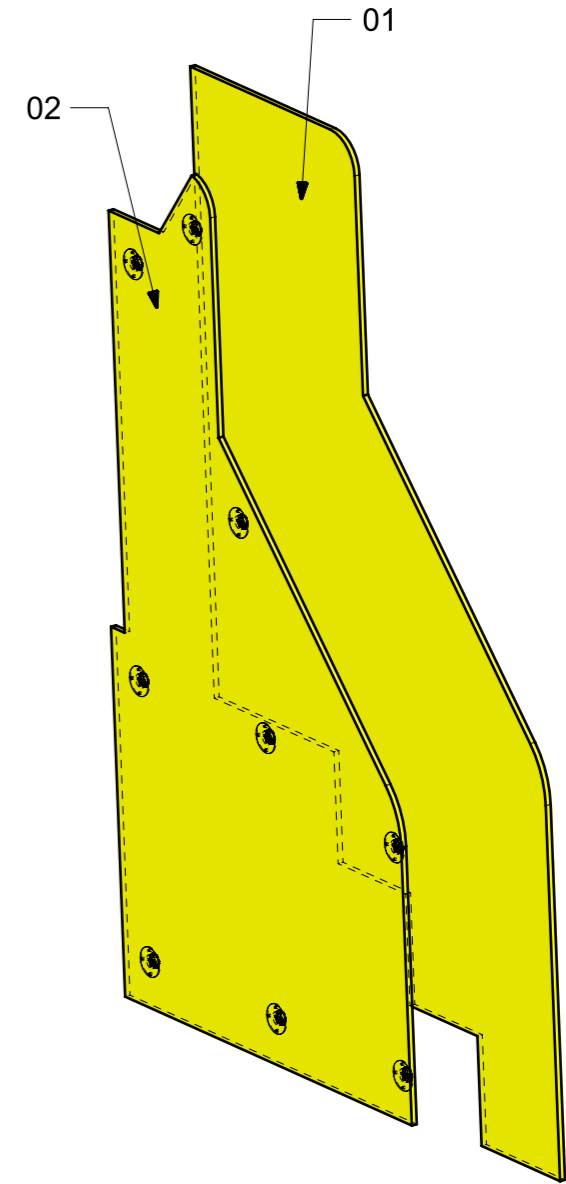

FERRAMENTA	QTY
FITLOCK M_MASCHERPA_3MM_6020202101	9

LOCALE	CODICE	DESCRIZIONE COMPONENTE	FINITURA	Q.TA
LOBBY	MD299_I01_CE01	MOBILE QUADRO ELETTRICO	OKUME' GREZZO	1

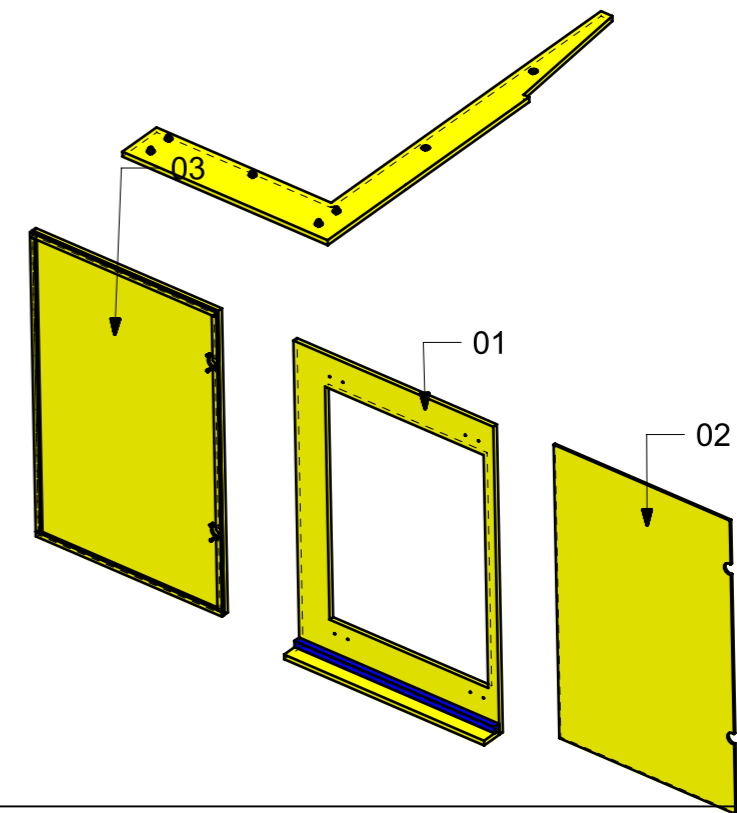
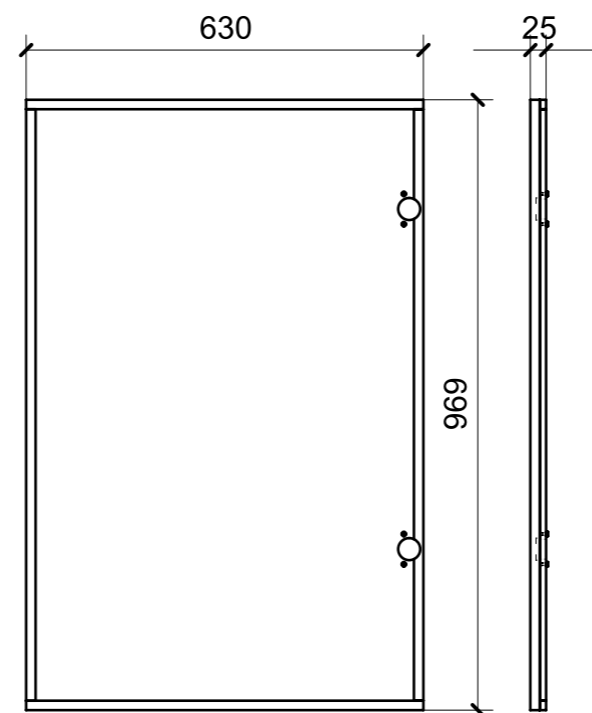
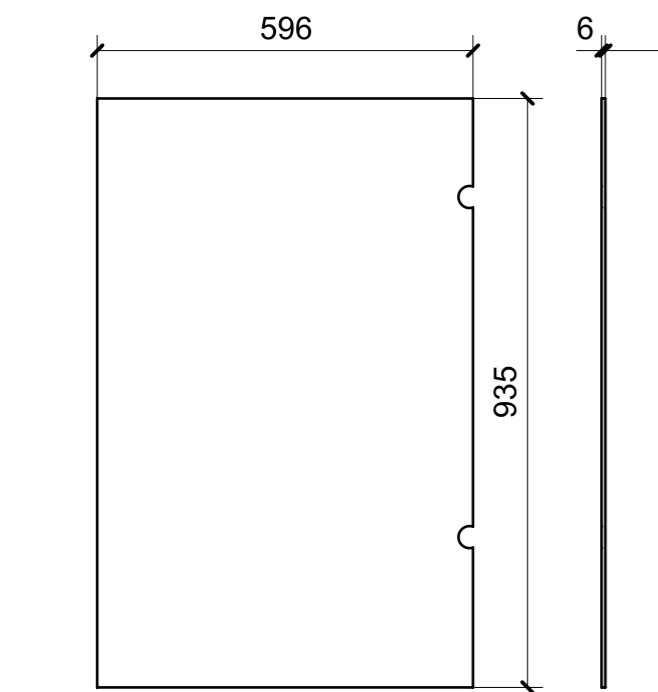
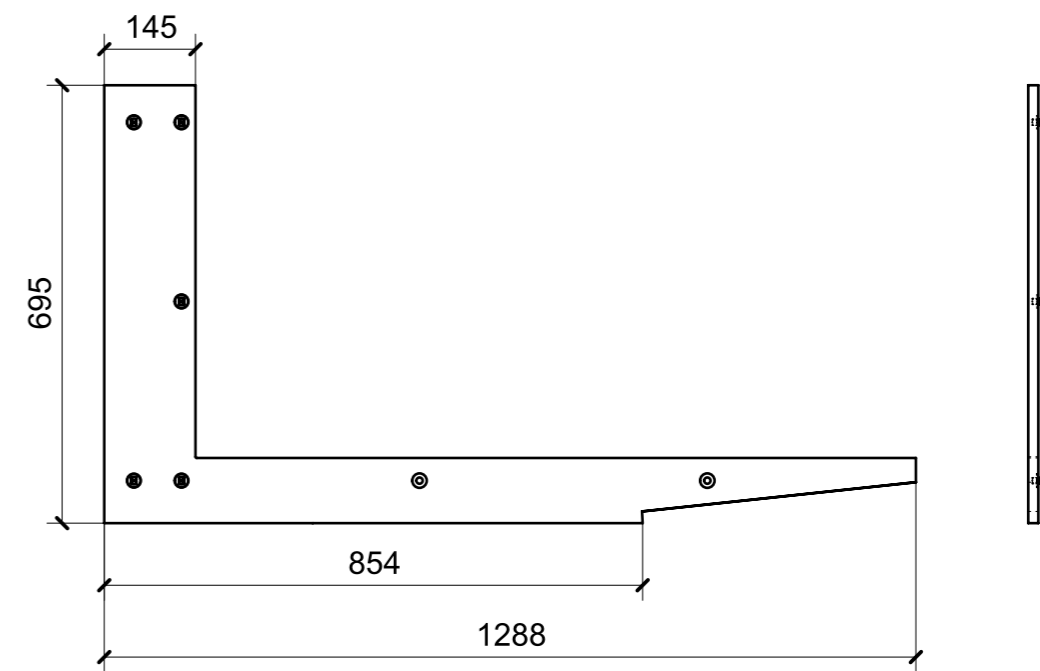
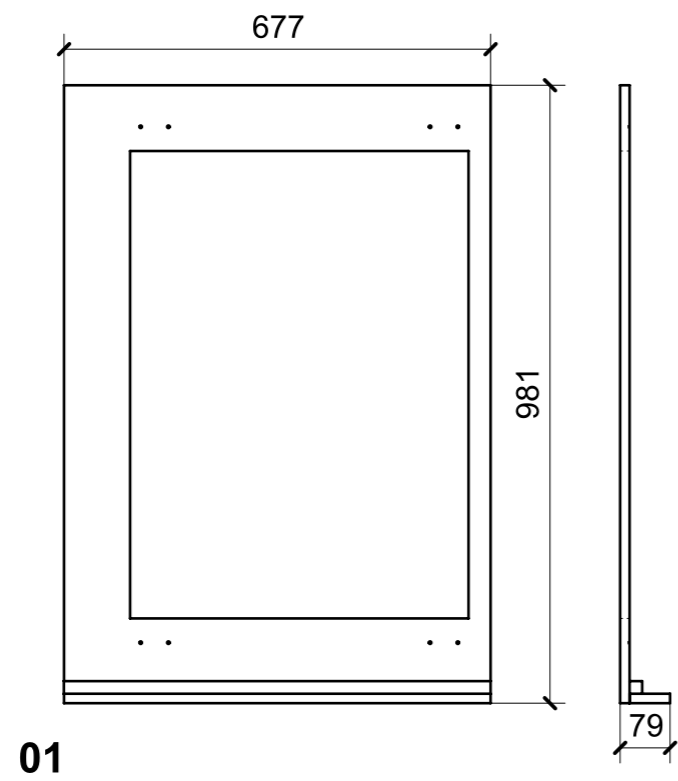

FERRAMENTA	QTY
BUSSOLA 5MA ANKOR BORGHI X CERNIERA COLLO PIENO	4
VITE 4MAX8 ANKOR BORGHI X CERNIERA COLLO PIENO	4

LOCALE	CODICE	DESCRIZIONE COMPONENTE	FINITURA	Q.TA
LOBBY	MD299_I01_CF01	RIV SCALE SX	OKUME' GREZZO	1

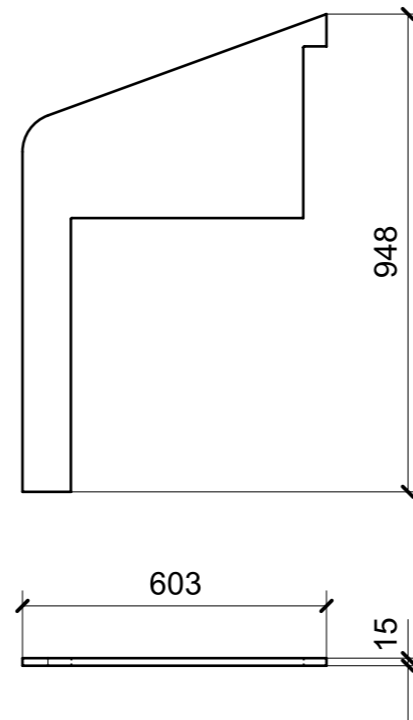
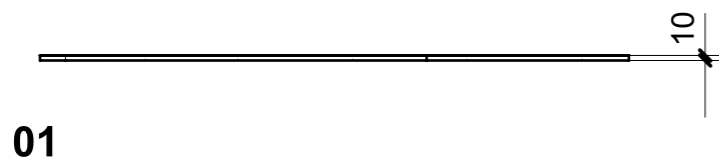
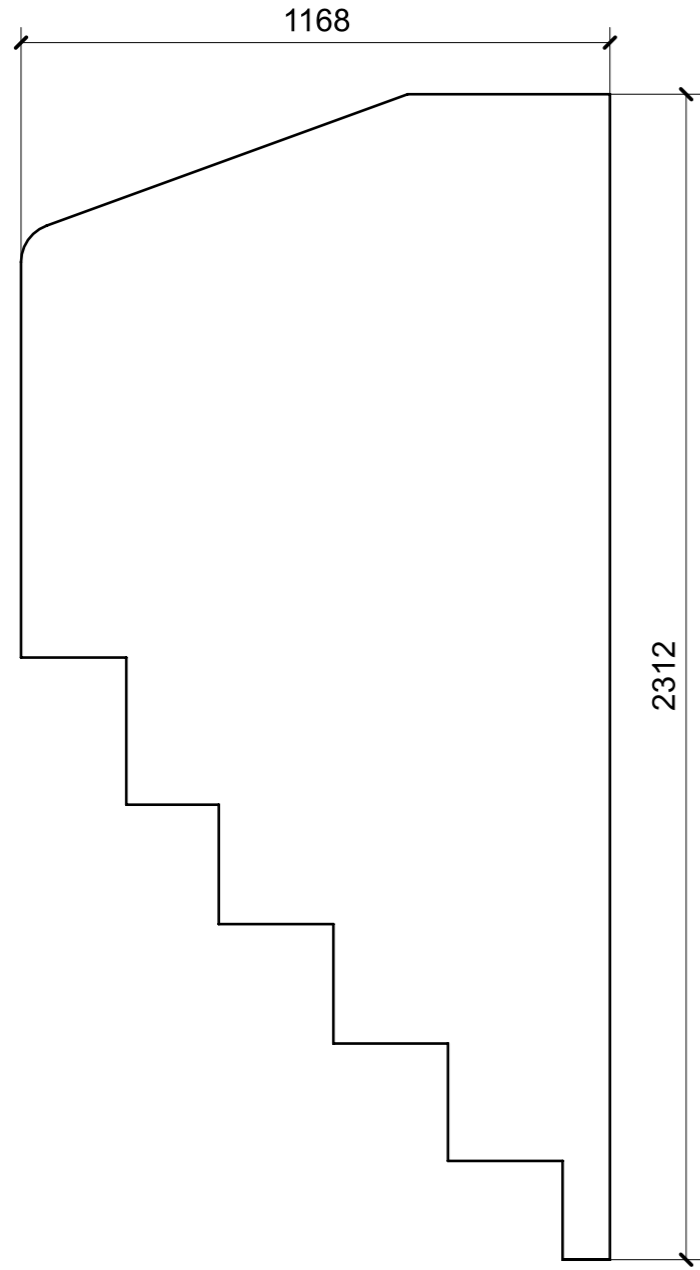

02

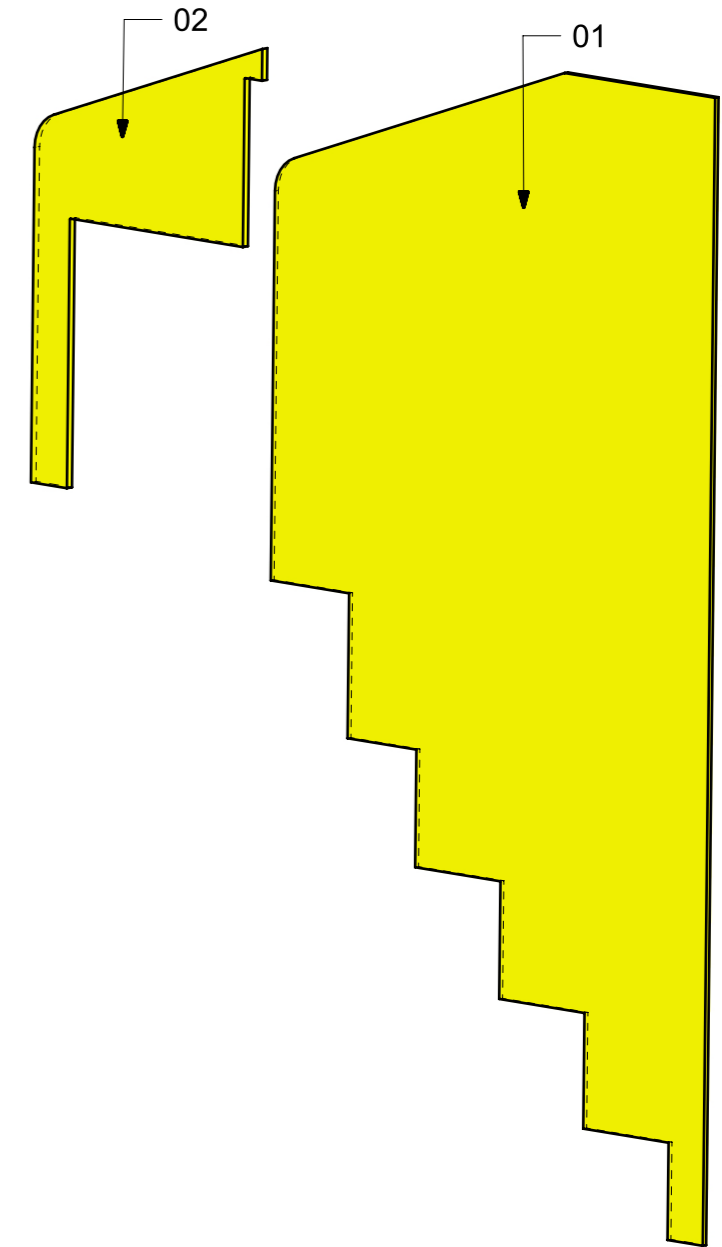

LOCALE	CODICE	DESCRIZIONE COMPONENTE	FINITURA	Q.TA
LOBBY	MD299_I01_CG01	RIV CORR. SX PORTA OSPITI	OKUME' GREZZO	1

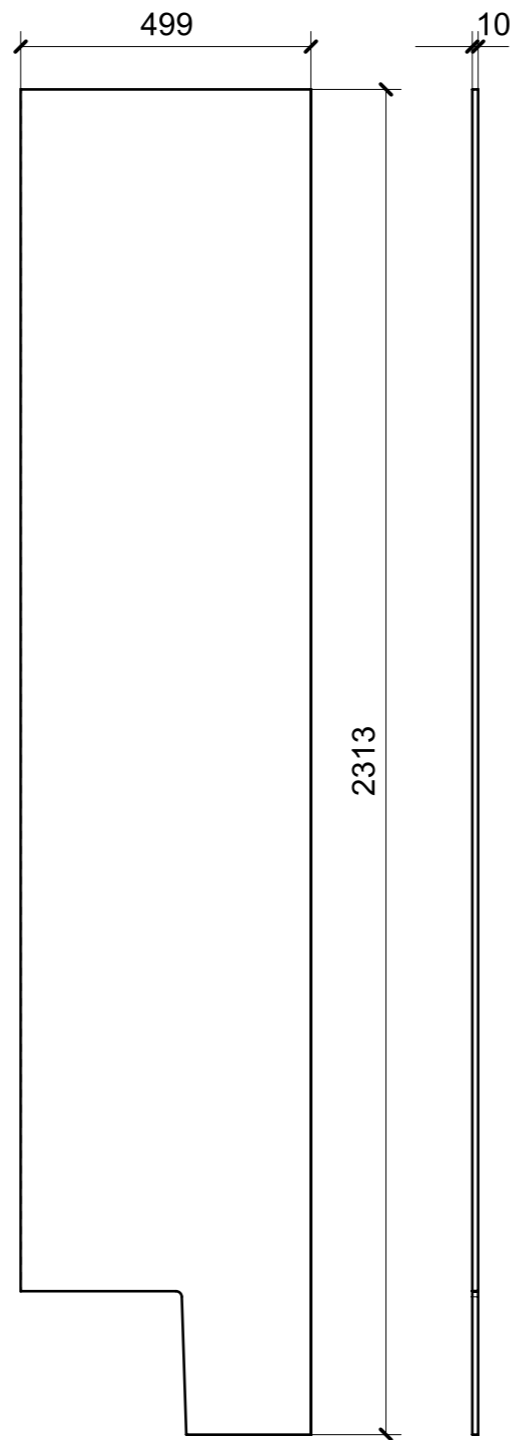

01

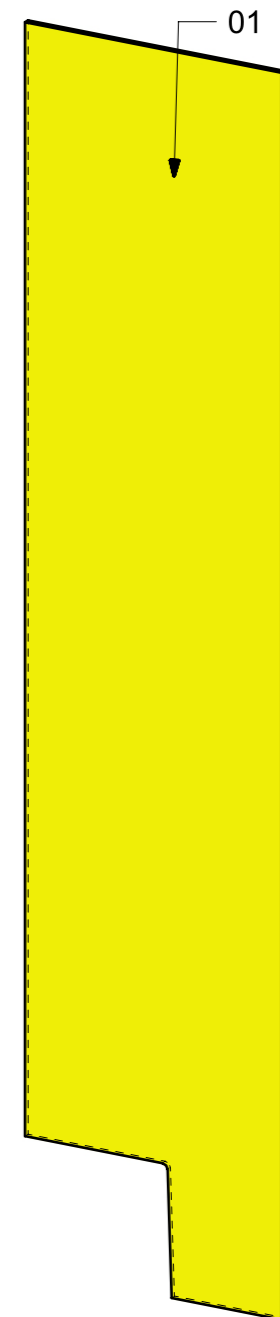

LOCALE	CODICE	DESCRIZIONE COMPONENTE	FINITURA	Q.TA
LOBBY	MD299_I01_CI01	RIV SCALE DX BAGNO	OKUME' GREZZO	1

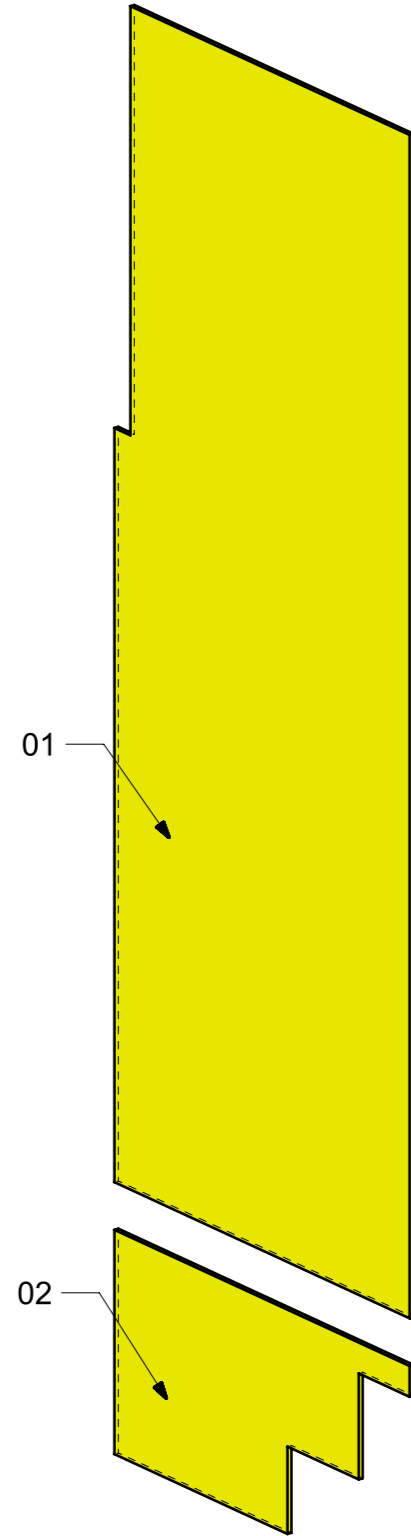
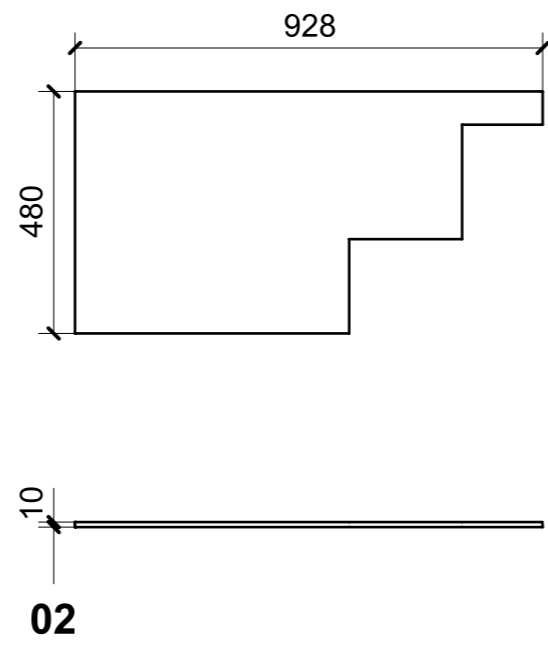
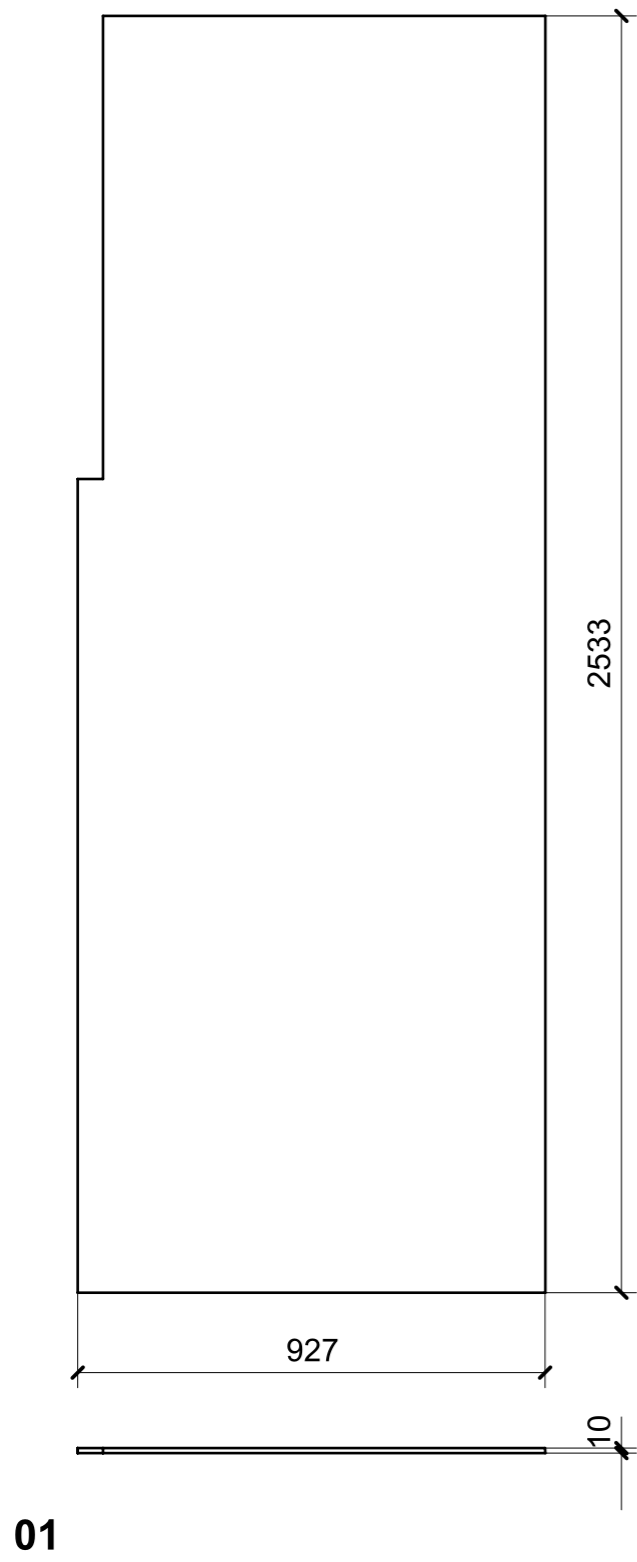

LOCALE	CODICE	DESCRIZIONE COMPONENTE	FINITURA	Q.TA
LOBBY	MD299_I01_CM01	RIV CORR. DX OSPITI CENT	OKUME' GREZZO	1

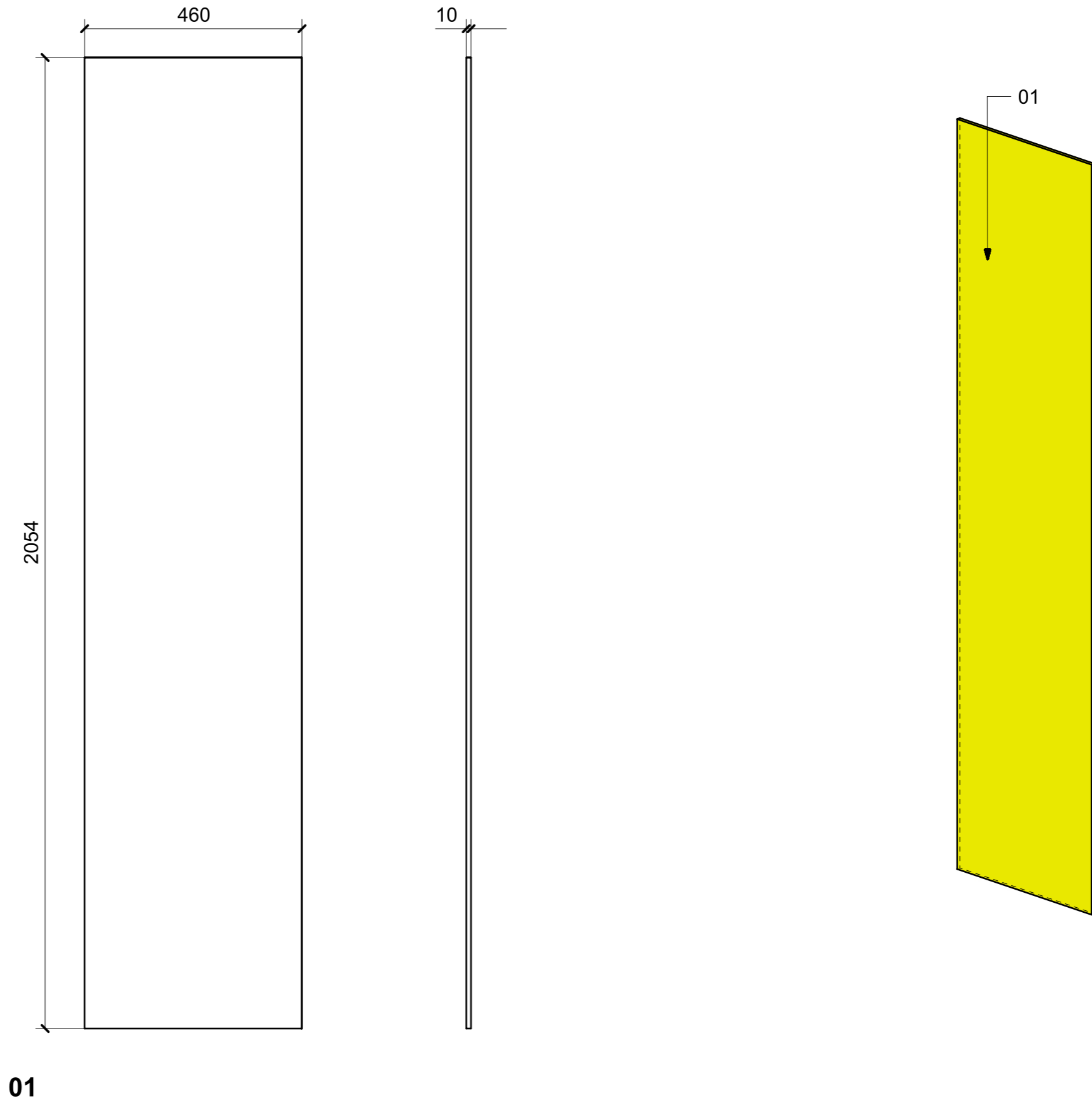

LOCALE	CODICE	DESCRIZIONE COMPONENTE	FINITURA	Q.TA
LOBBY	MD299_I01_CN01	RIV CORR. DX OSPITI PRUA	OKUME' GREZZO	1

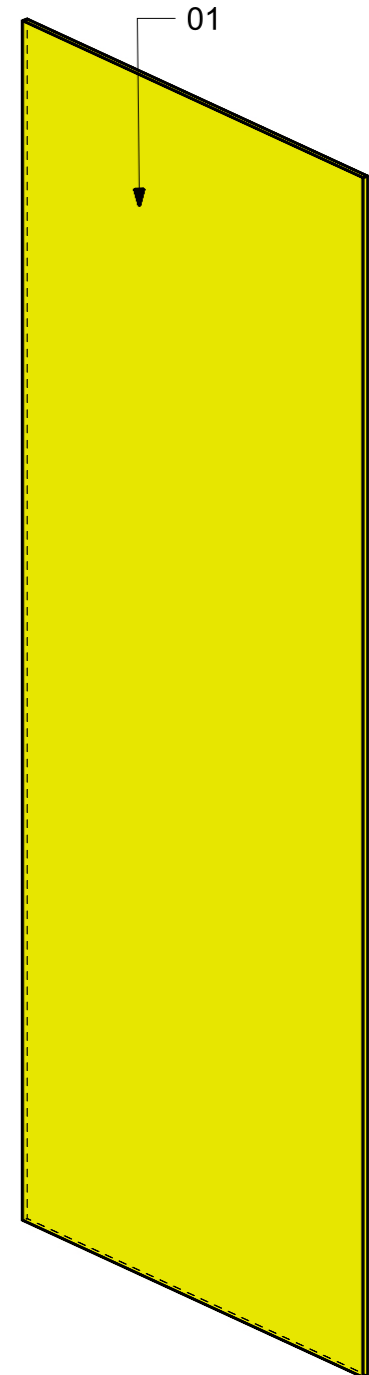
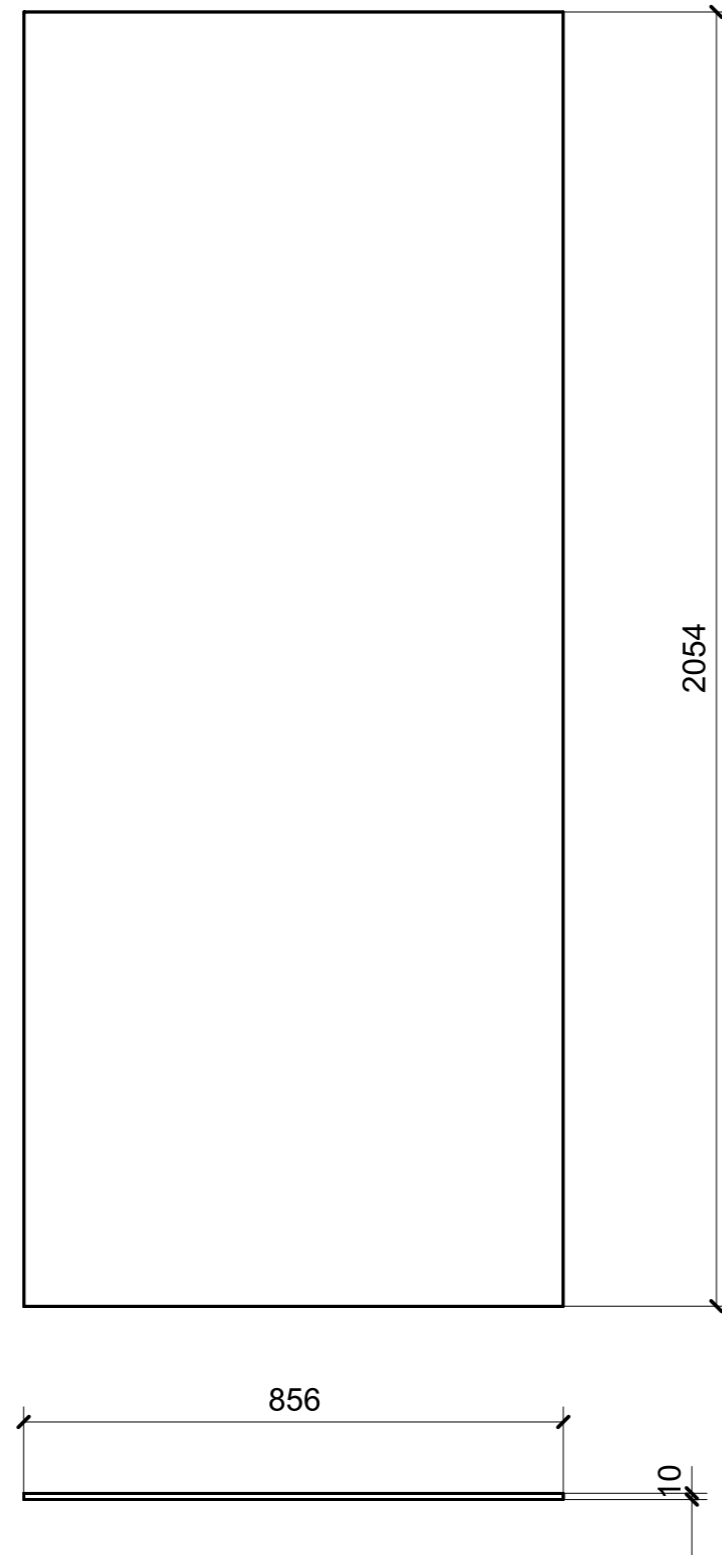

01

LOCALE	CODICE	DESCRIZIONE COMPONENTE	FINITURA	Q.TA
FRONTE MARCIA	MD299_I01_FA01	STRUTTURA ANTIRIFLESSO SX	OKUME' GREZZO	1

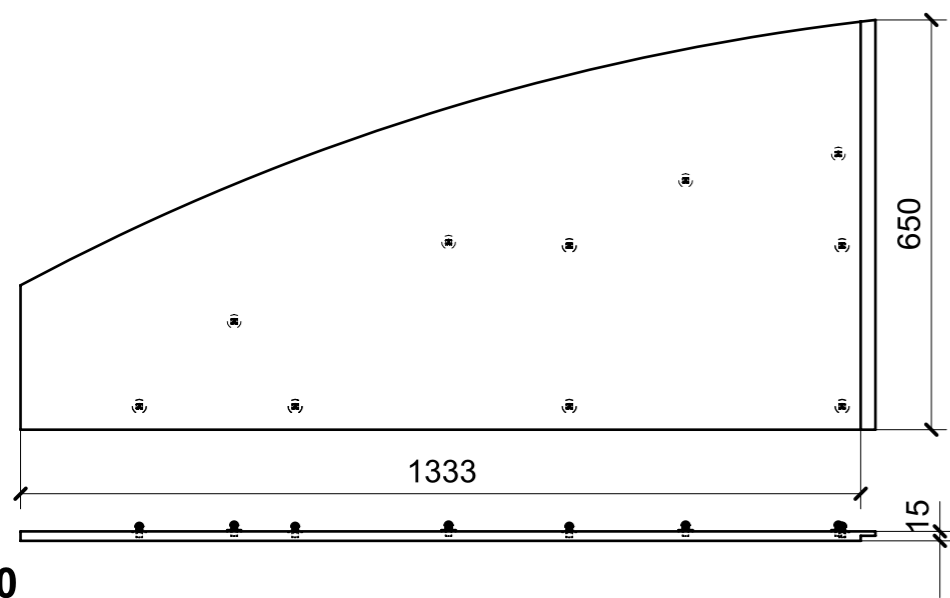
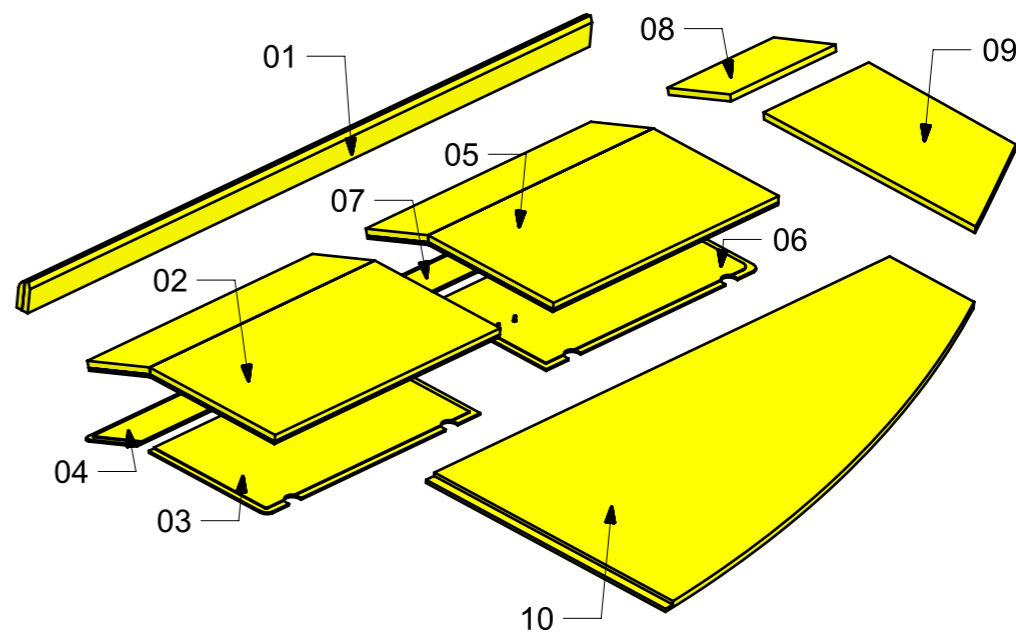
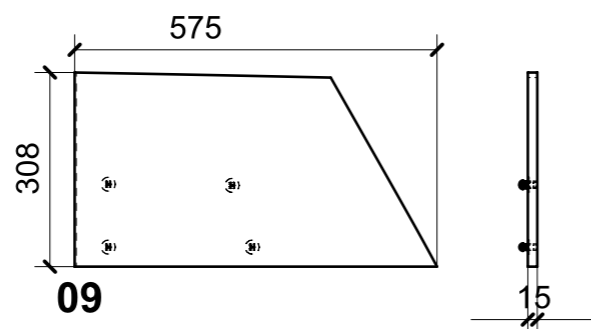
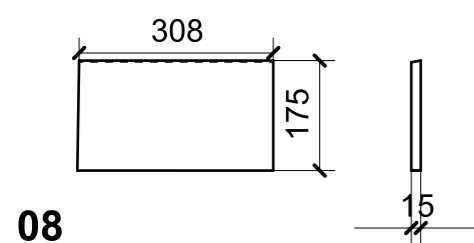
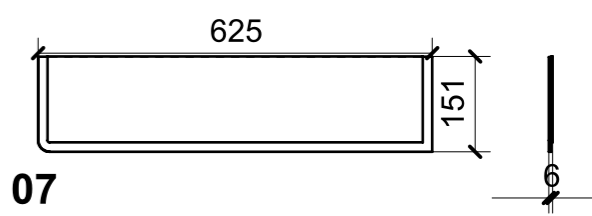
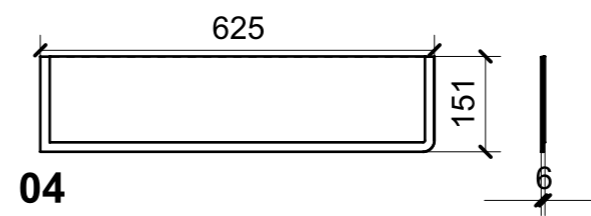
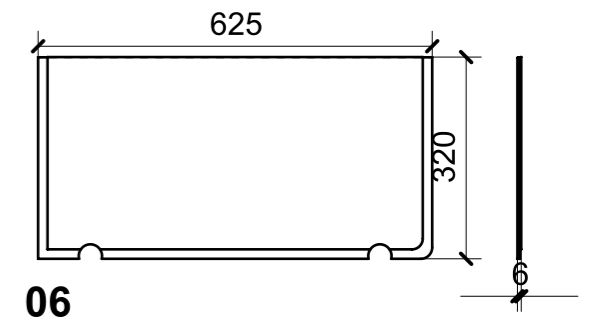
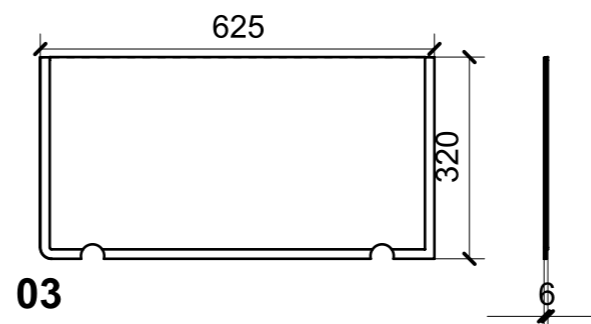
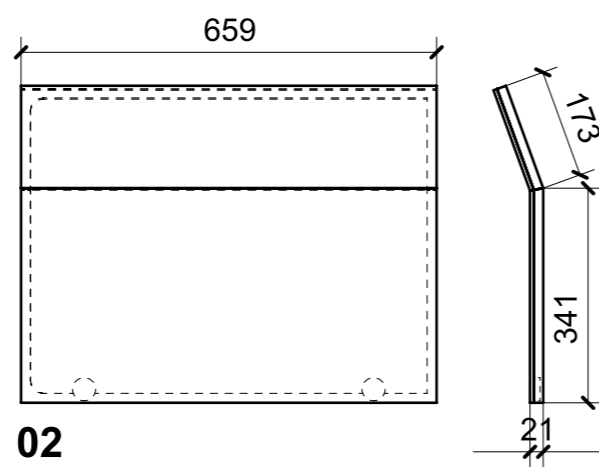
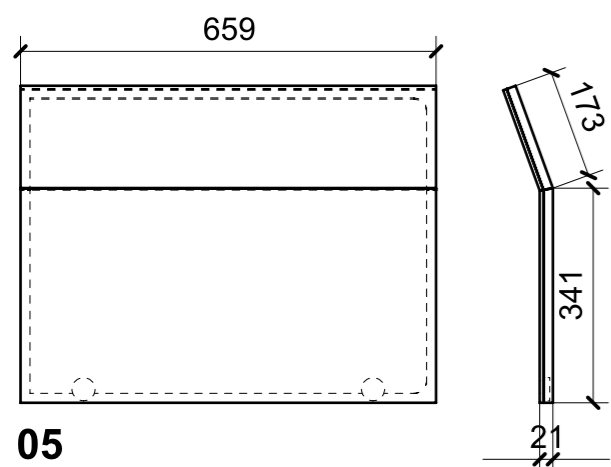
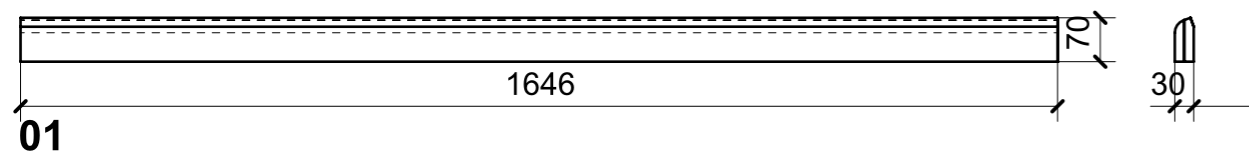

FERRAMENTA	QTY
MS INCASSO_ITALVIPLA_972_FMPC_M1B	14

LOCALE	CODICE	DESCRIZIONE COMPONENTE	FINITURA	Q.TA
FRONTE MARCIA	MD299_I01_FB01	STRUTTURA ANTIRIFLESSO DX	OKUME' GREZZO	1

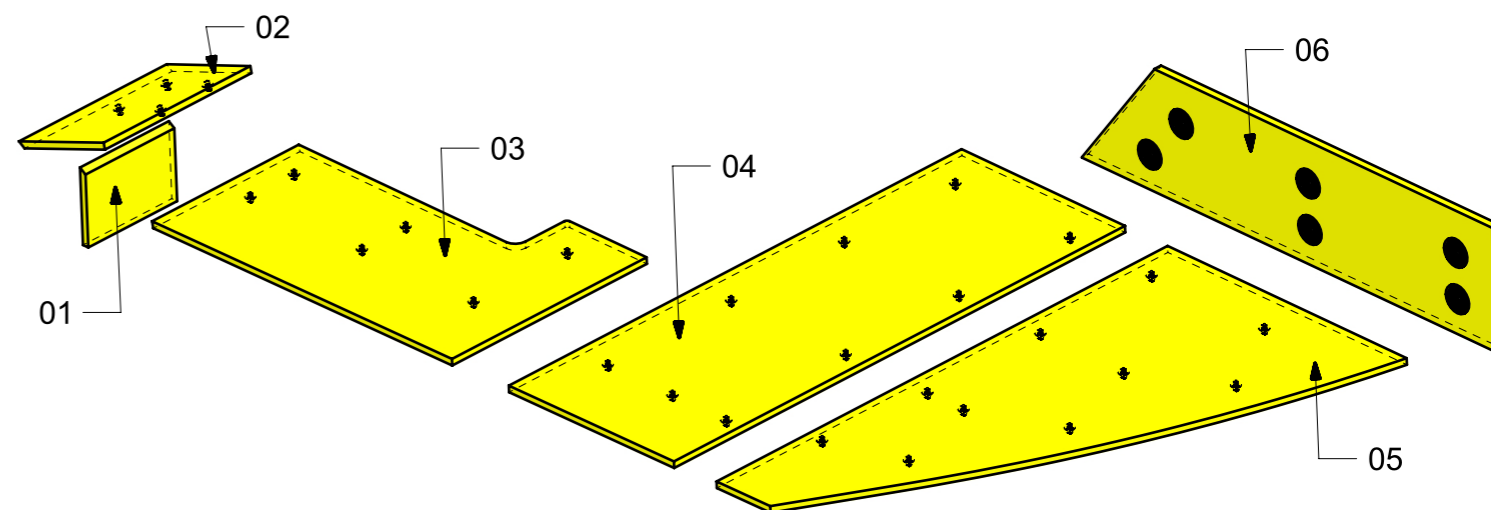
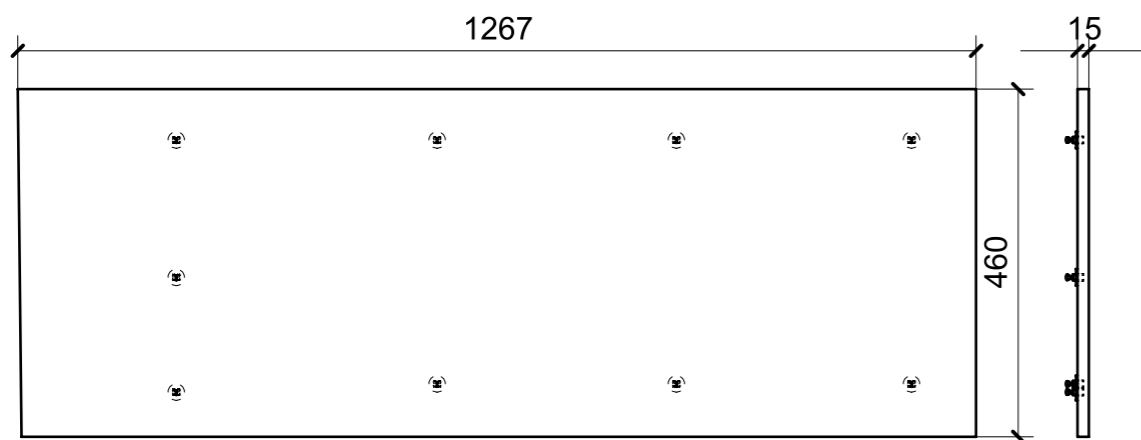
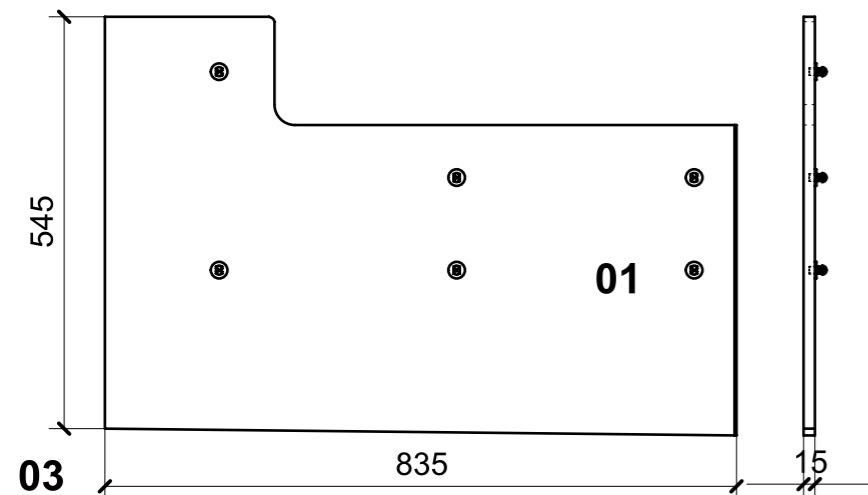
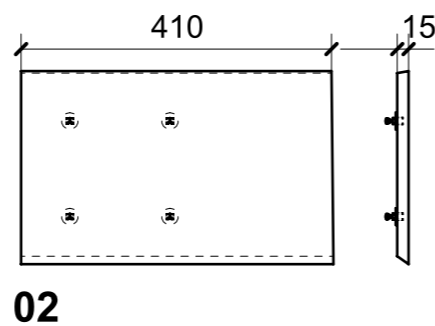
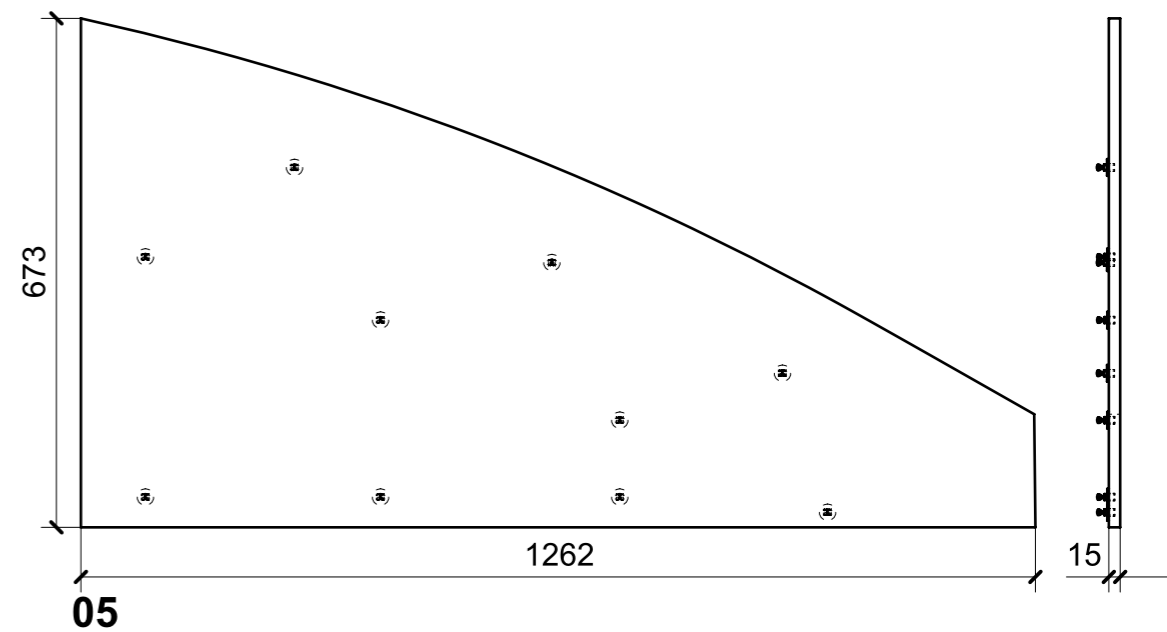
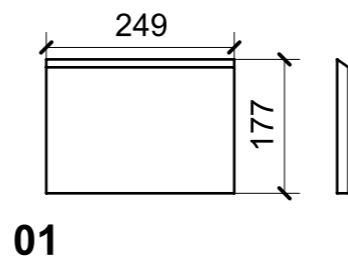
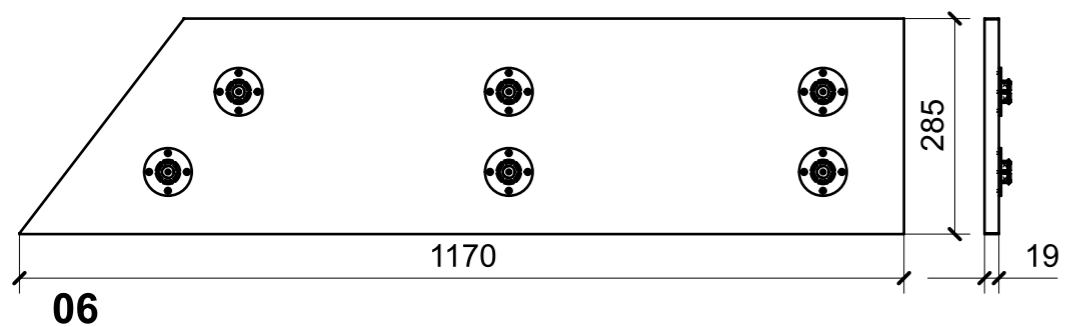

FERRAMENTA	QTY
MS INCASSO_ITALVIPLA_972_FMPC_M1B	29
FITLOCK M_MASCHERPA_3MM_6020202101	6

LOCALE	CODICE	DESCRIZIONE COMPONENTE	FINITURA	Q.TA
FRONTE MARCIA	MD299_I01_FC01	STRUTTURA DX FIANCO SCALA	OKUME' GREZZO	1

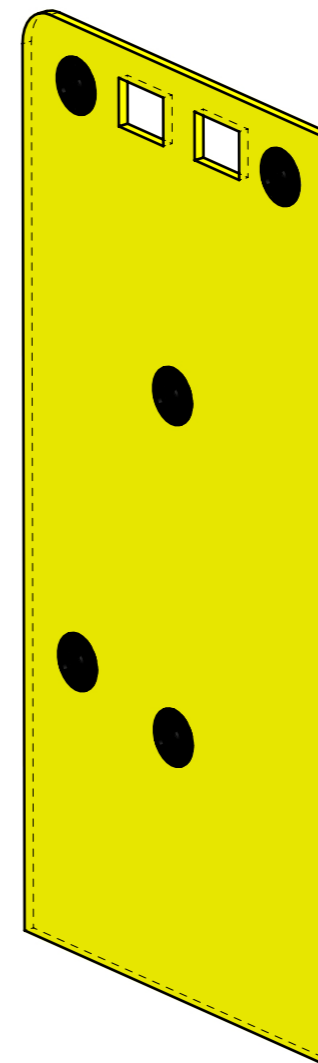
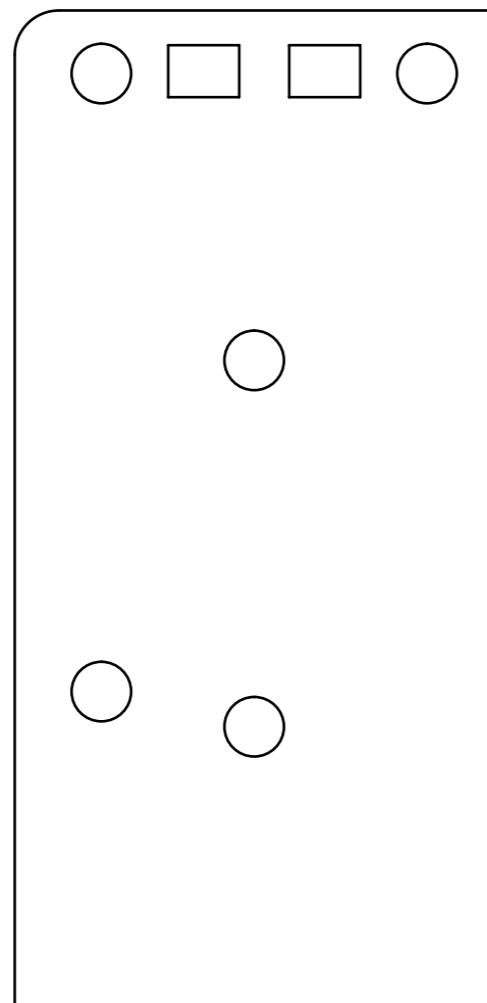

FERRAMENTA	QTY
FITLOCK M_MASCHERPA_3MM_6020202101	5

LOCALE	CODICE	DESCRIZIONE COMPONENTE	FINITURA	Q.TA
FRONTE MARCIA	MD299_I01_FD01	SOTTO CRUSCOTTO	OKUME' GREZZO	1

01

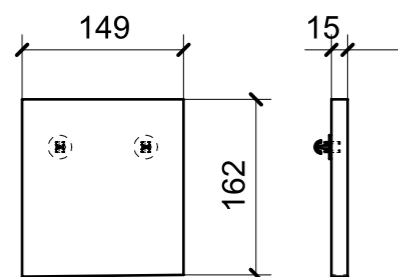

02

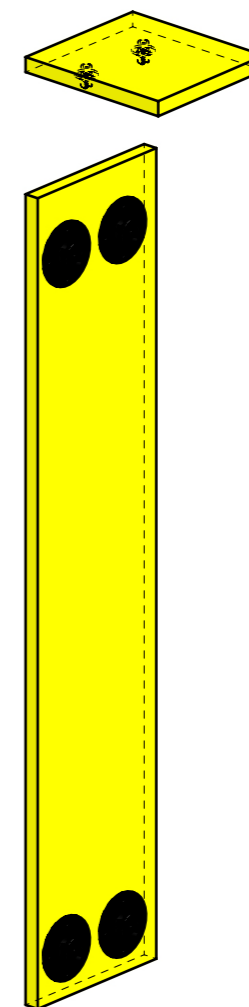
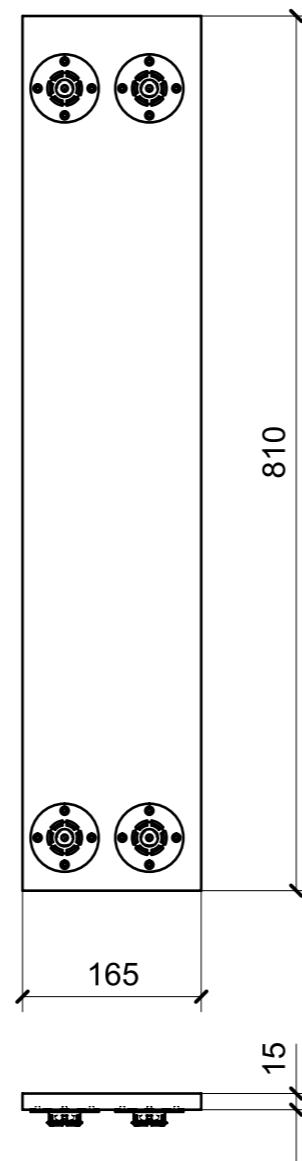

FERRAMENTA	QTY
MS INCASSO_ITALVIPLA_972_FMPC_M1B	2
FITLOCK M_MASCHERPA_3MM_6020202101	4

LOCALE	CODICE	DESCRIZIONE COMPONENTE	FINITURA	Q.TA
FRONTE MARCIA	MD299_I01_FE01	RIVESTIMENTO CRUSCOTTO	OKUME' GREZZO	1

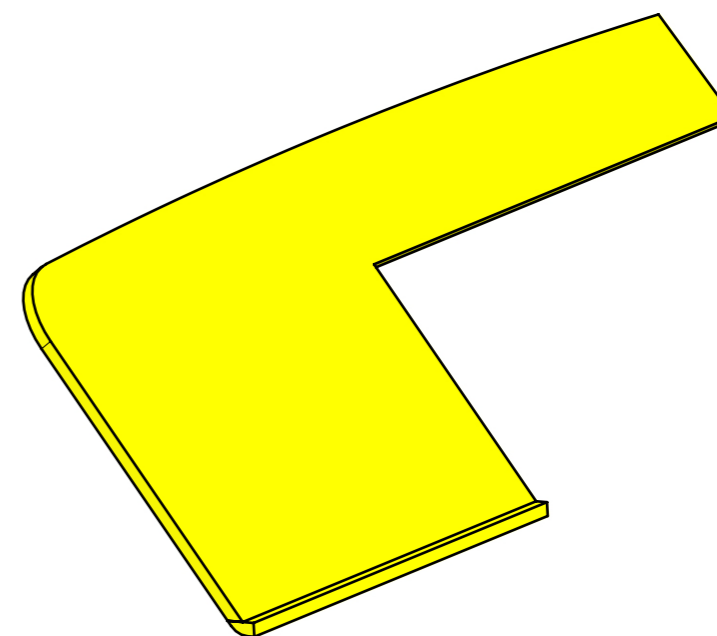
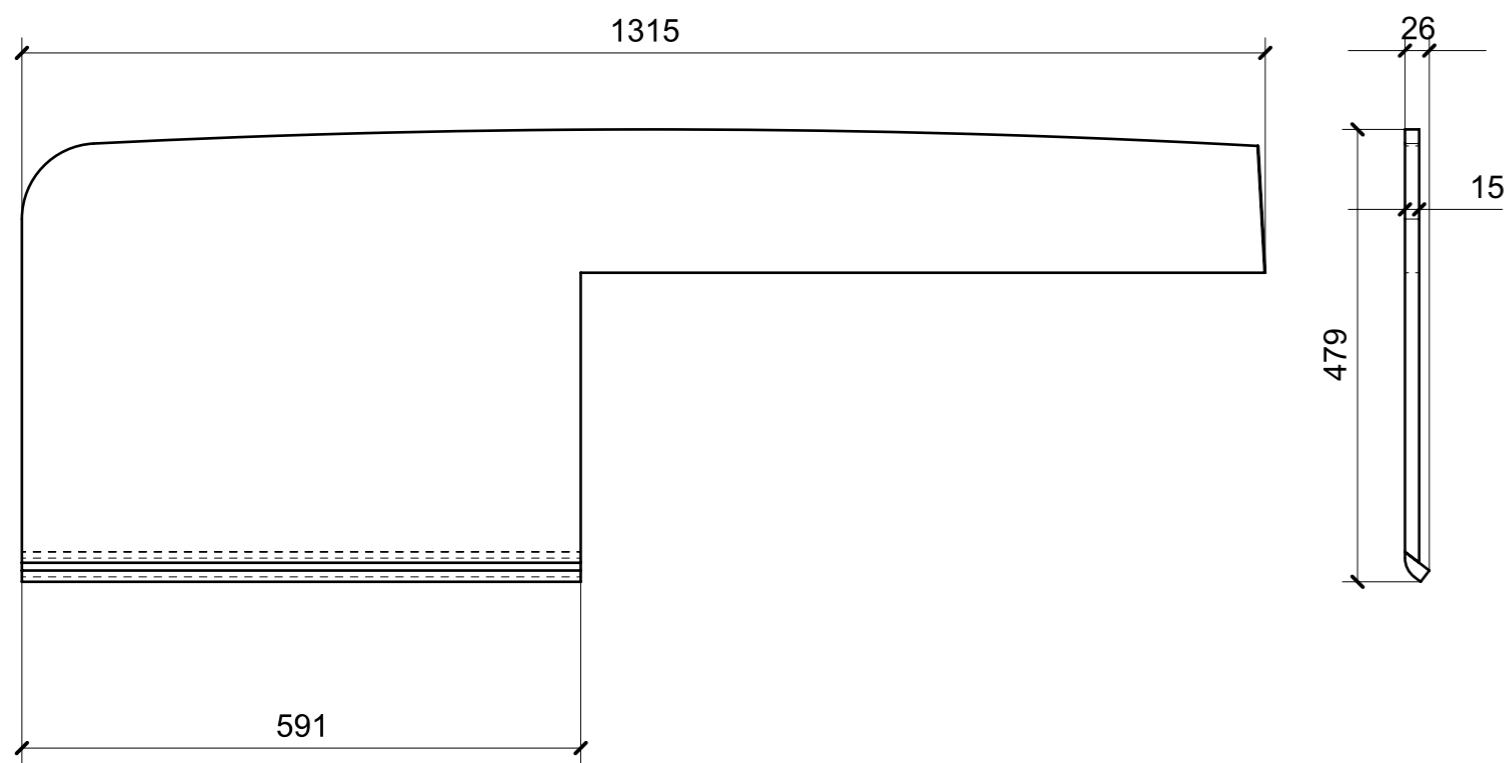

LOCALE	CODICE	DESCRIZIONE COMPONENTE	FINITURA	Q.TA
FRONTE MARCIA	MD299_I01_FF01	MOBILE SOTTOGUIDA VASELLAME	OKUME' GREZZO	1

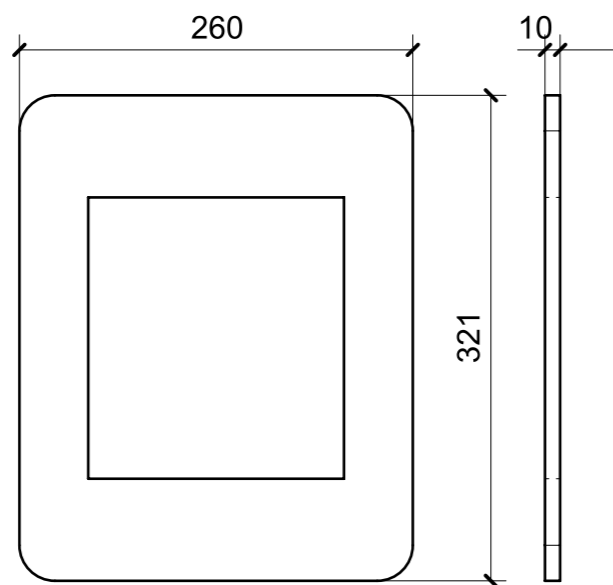

01

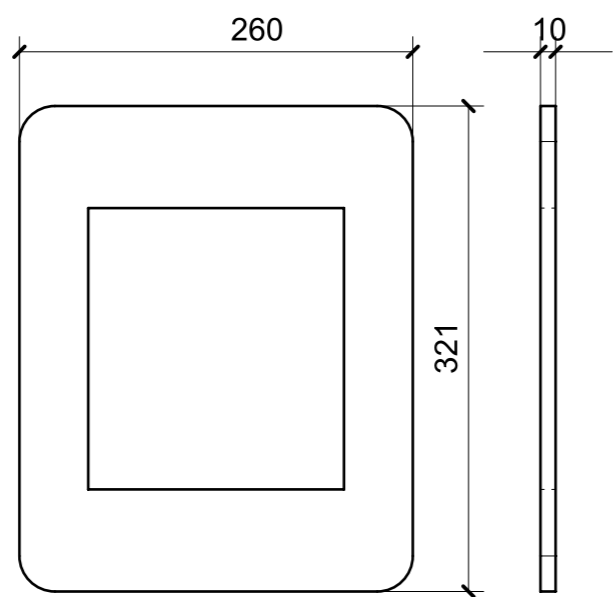

02

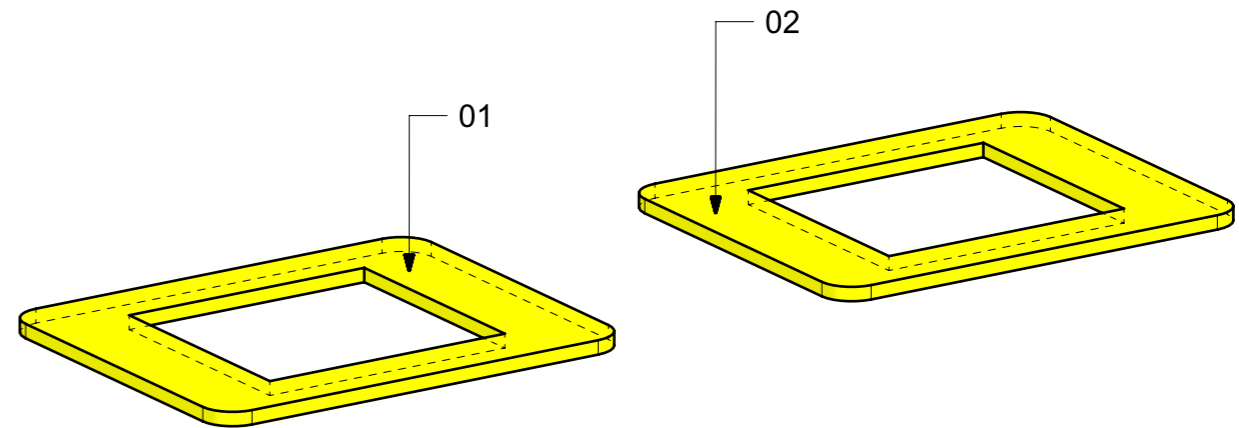

LOCALE	CODICE	DESCRIZIONE COMPONENTE	FINITURA	Q.TA
FRONTE MARCIA	MD299_I01_FG01	RIV. MURETTO DIVISORIO MOBILE GUIDA	OKUME' GREZZO	1

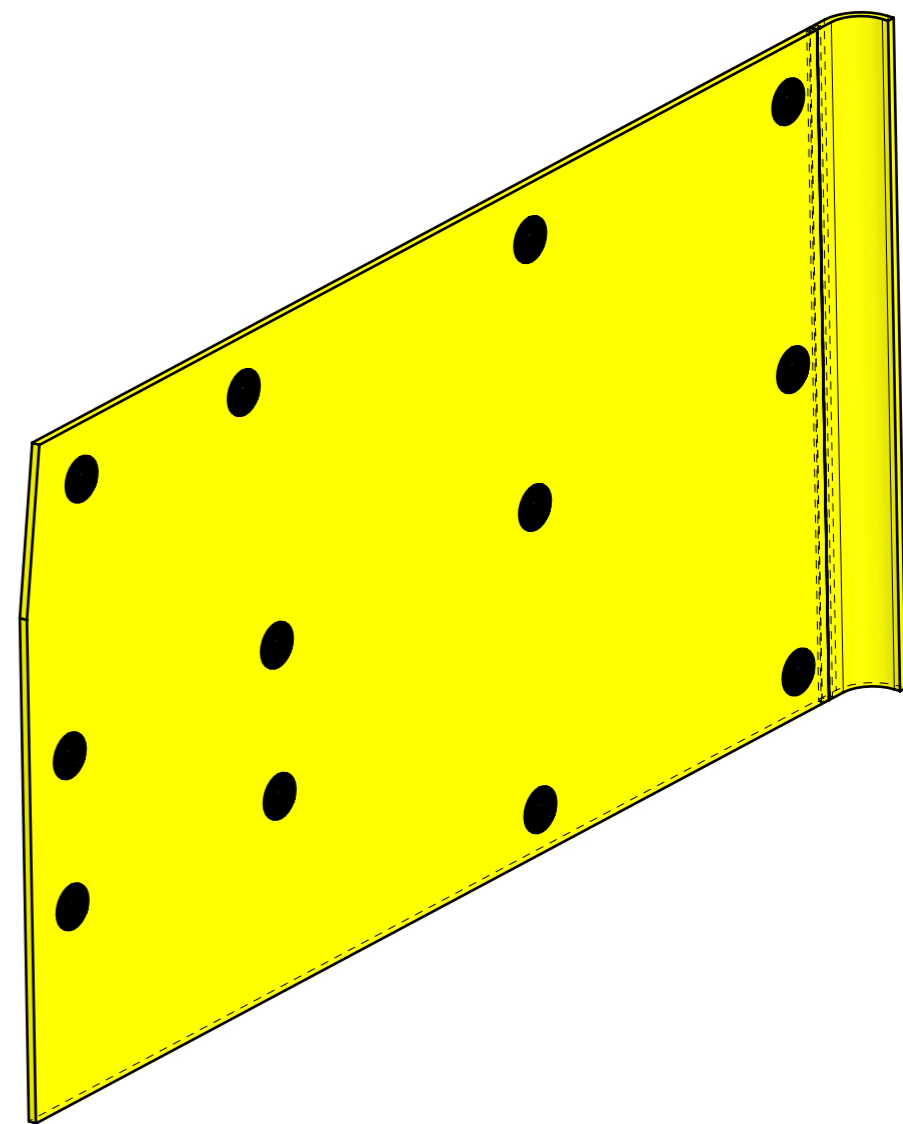
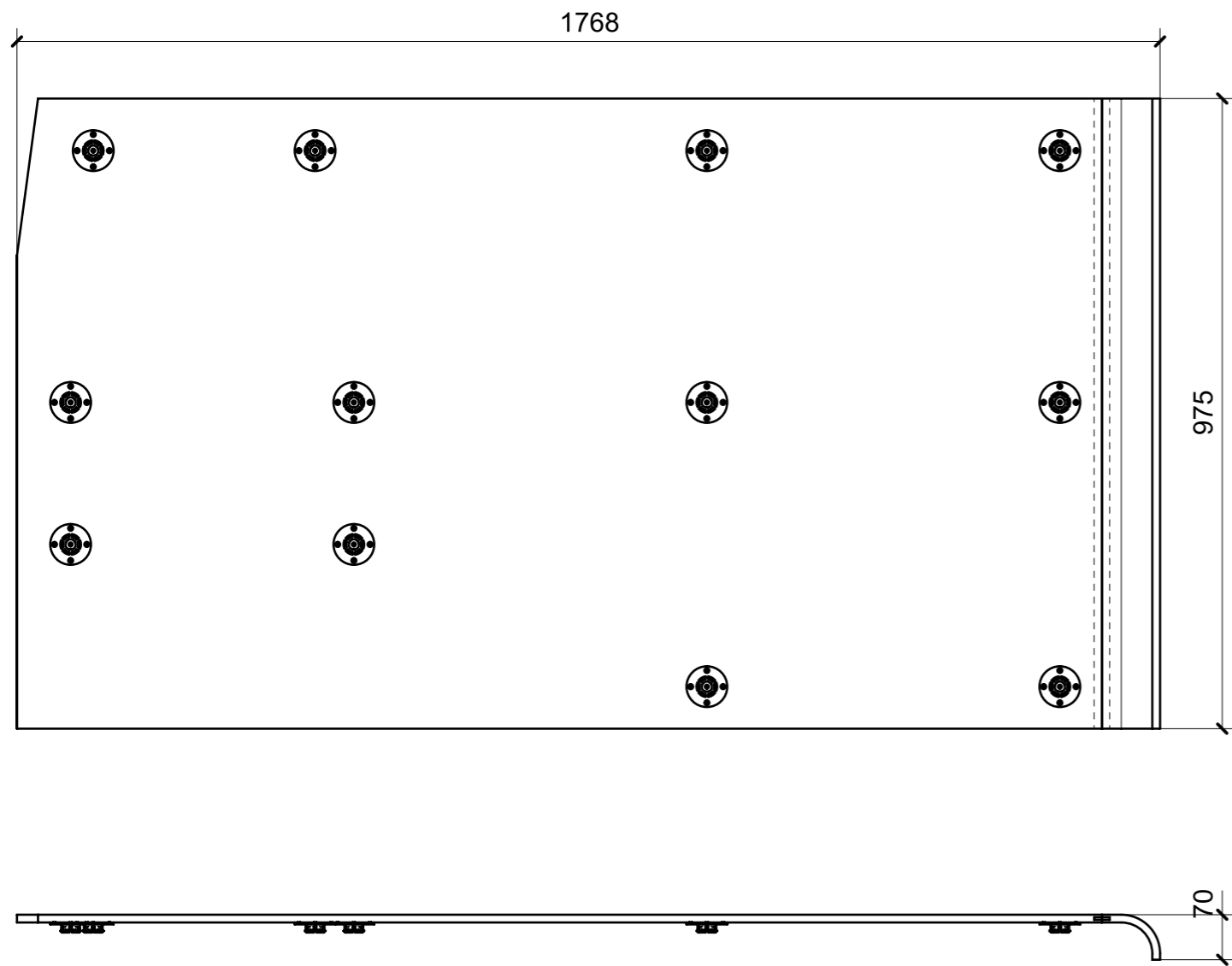

FERRAMENTA	QTY
FITLOCK M_MASCHERPA_3MM_6020202101	12

LOCALE	CODICE	DESCRIZIONE COMPONENTE	FINITURA	Q.TA
FRONTE MARCIA	MD299_I01_FH01	DIVANO DINETTE PRUA	OKOUME' GREZZO	1

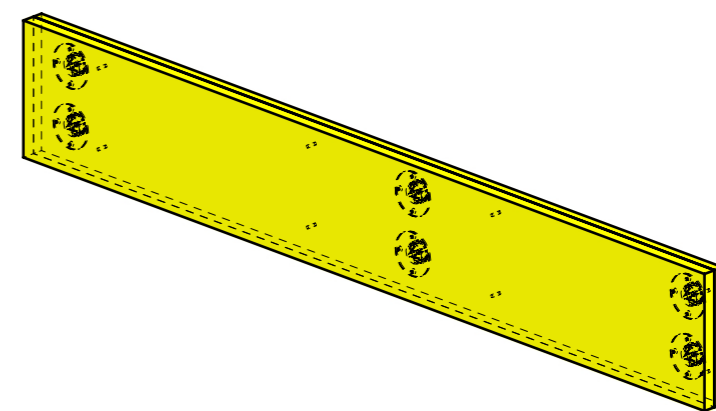
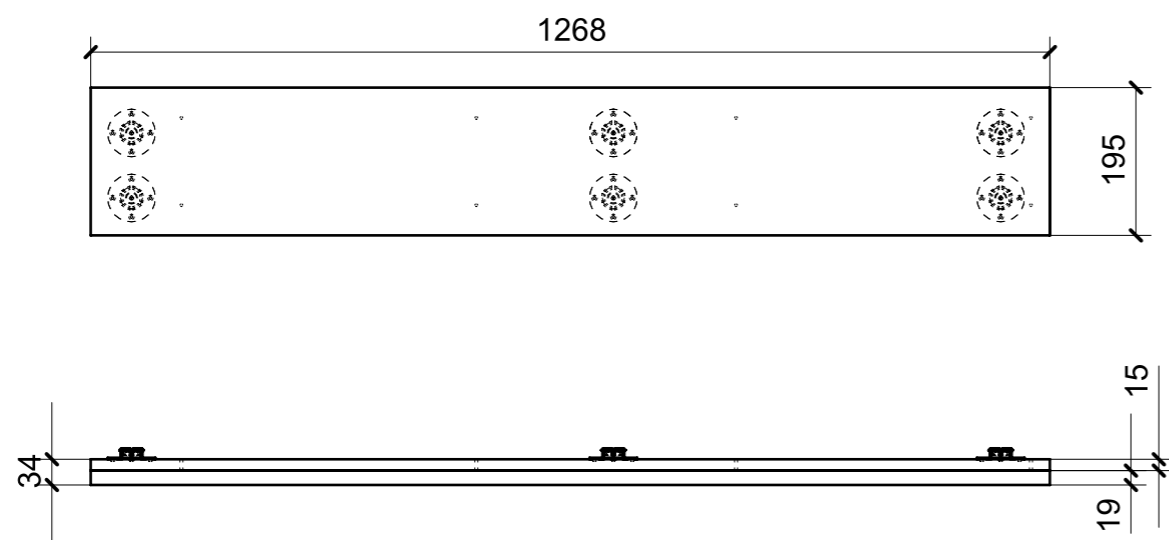

FERRAMENTA	QTY
FITLOCK M_MASCHERPA_3MM_6020202101	6

LOCALE	CODICE	DESCRIZIONE COMPONENTE	FINITURA	Q.TA
FRONTE MARCIA	MD299_I01_FL01	DIVANO DINETTE POPPA	OKOUME' GREZZO	1

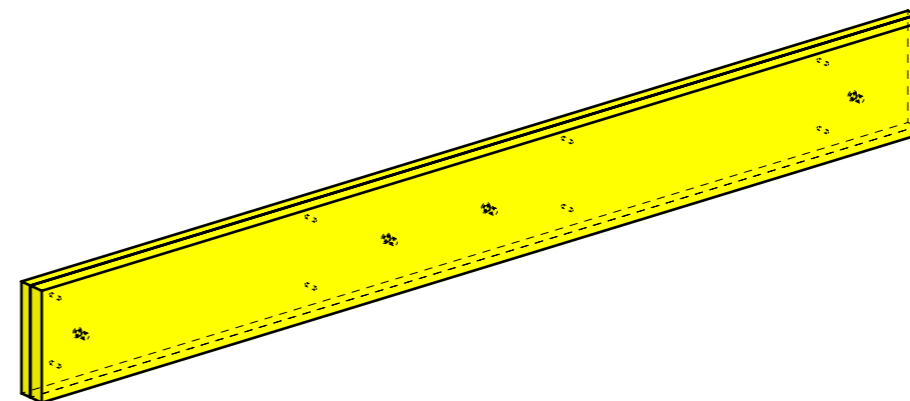
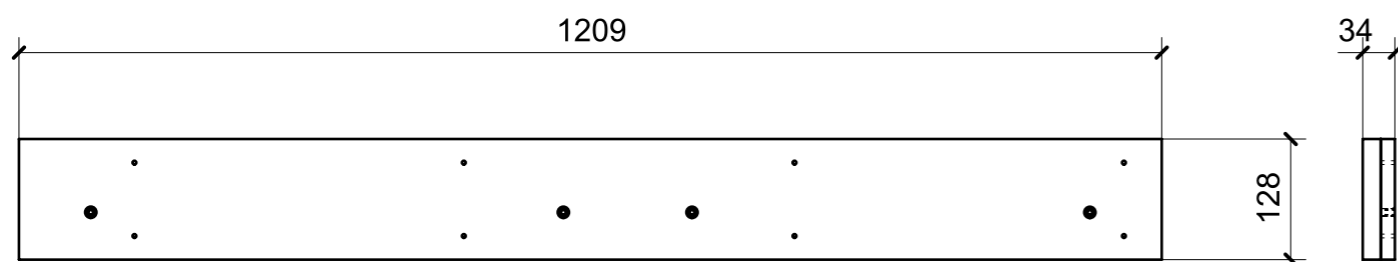

FERRAMENTA	QTY
BUSSOLA 5MA X 10 FORO DIAM.8	4

LOCALE	CODICE	DESCRIZIONE COMPONENTE	FINITURA	Q.TA
SALONE	MD299_I01_SA01	COLONNA SX POPPA	OKUME' GREZZO	1

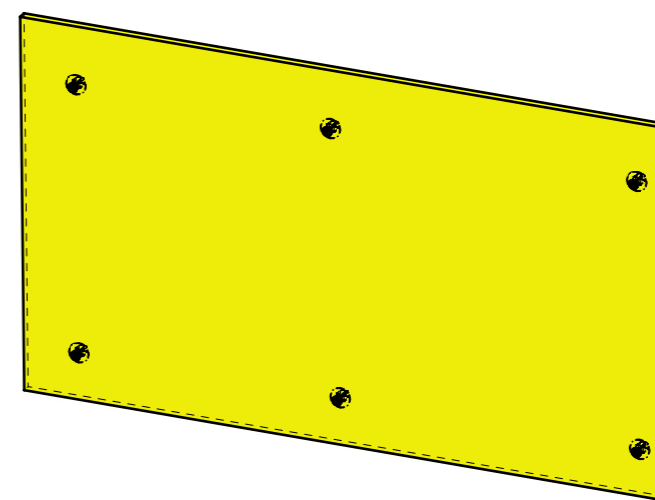
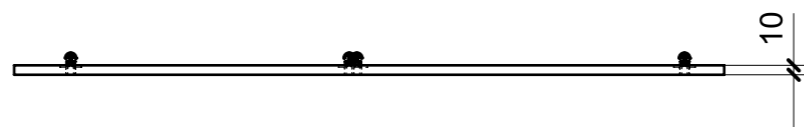

FERRAMENTA	QTY
MS INCASSO_ITALVIPLA_972_FMPC_M1B	6

LOCALE	CODICE	DESCRIZIONE COMPONENTE	FINITURA	Q.TA
SALONE	MD299_I01_SB01	COLLEGAMENTO BASSO SX	OKUME' GREZZO	1

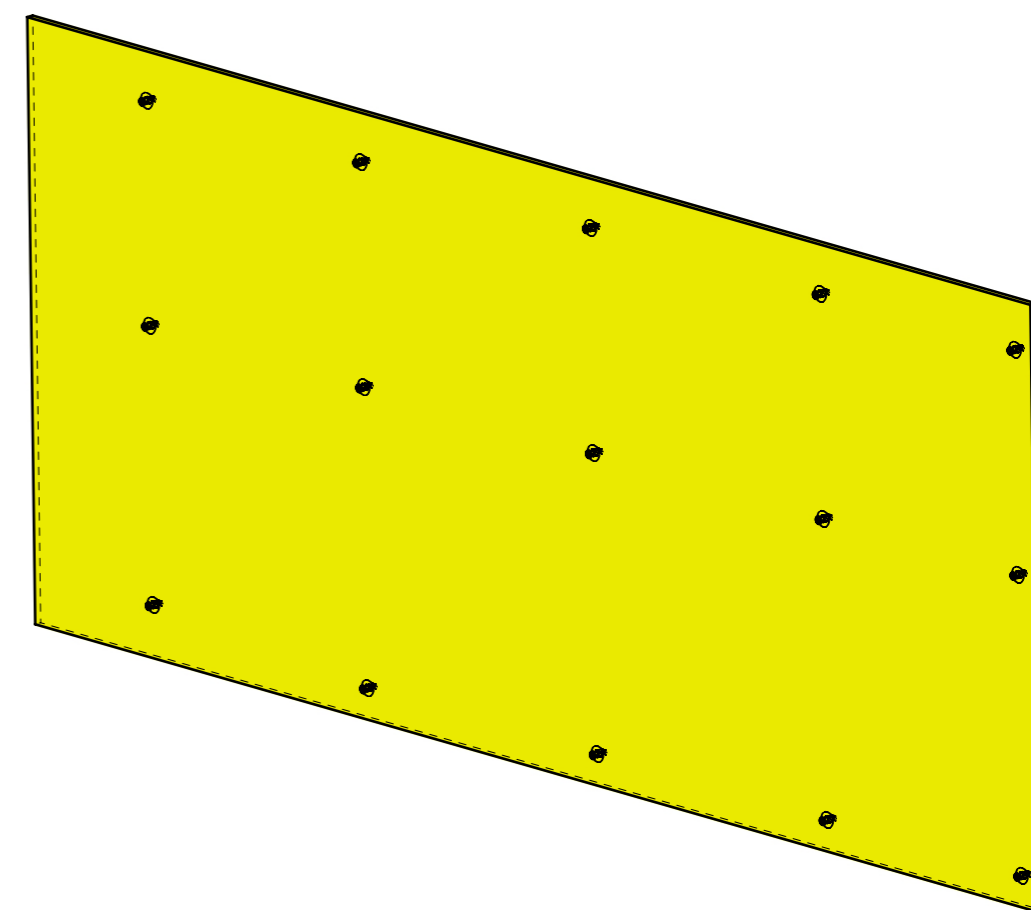
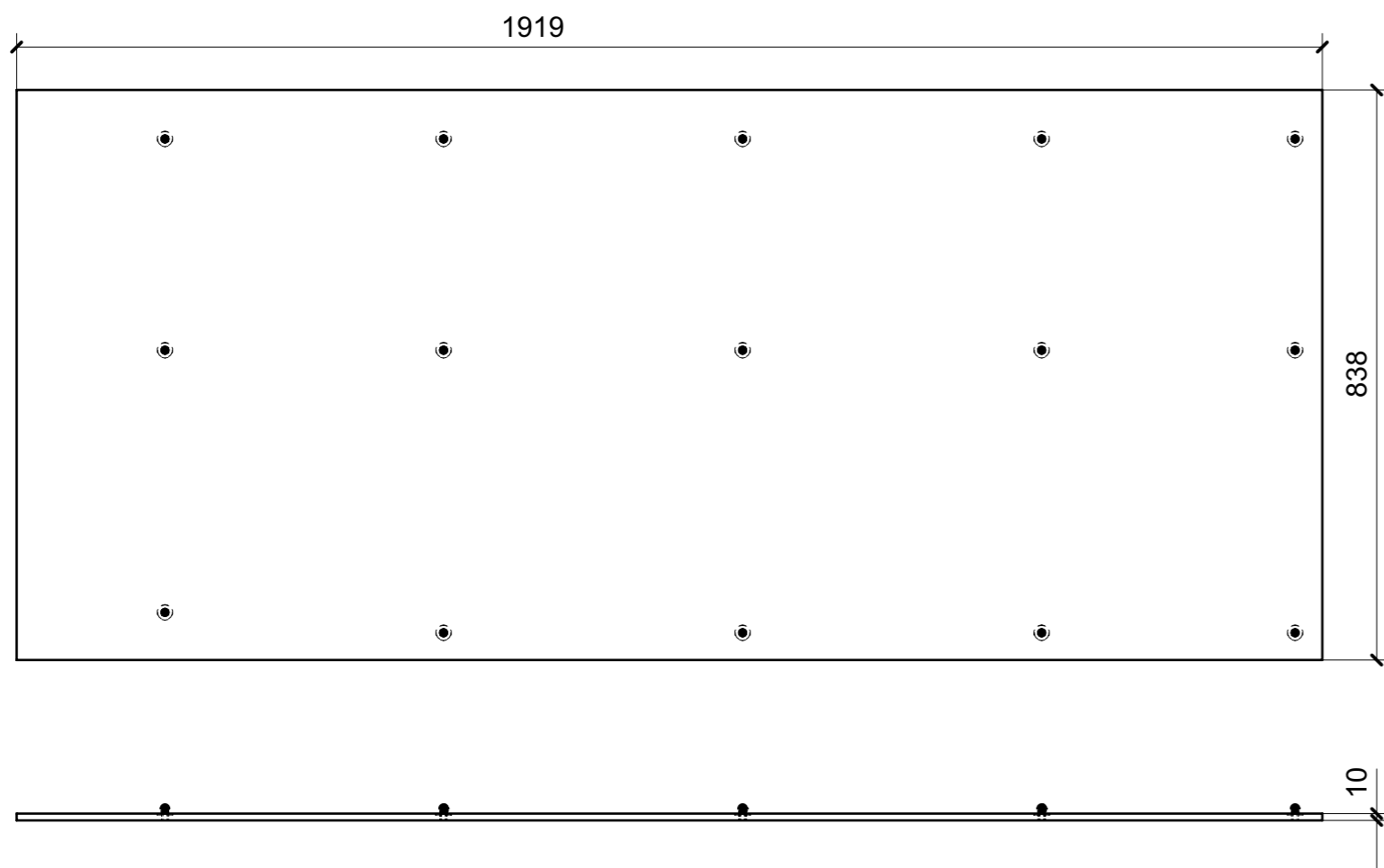

FERRAMENTA	QTY
MS INCASSO_ITALVIPLA_972_FMPC_M1B	15

LOCALE	CODICE	DESCRIZIONE COMPONENTE	FINITURA	Q.TA
SALONE	MD299_I01_SC01	STRUTTURA SX PRUA	OKUME' GREZZO	1

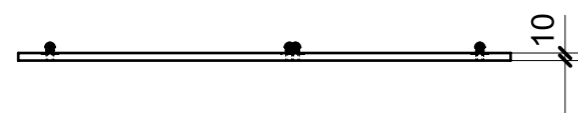
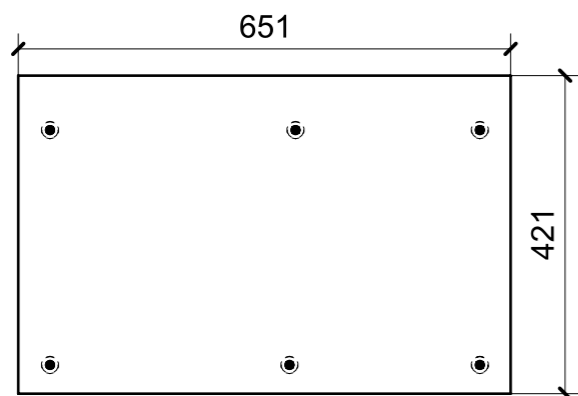

01

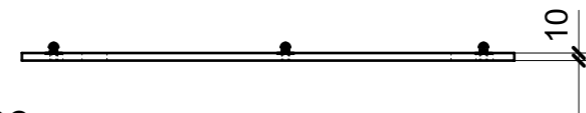
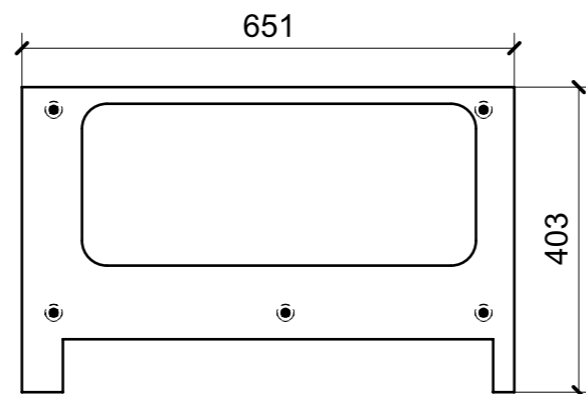

03

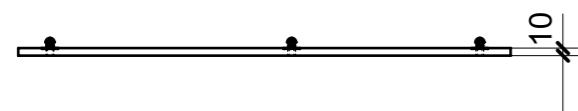
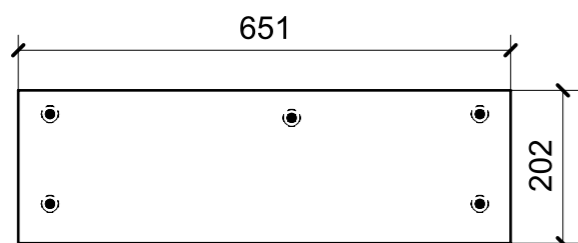

02

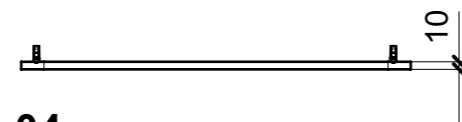
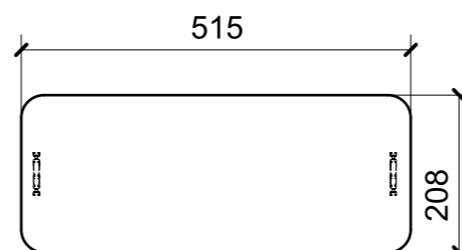

04

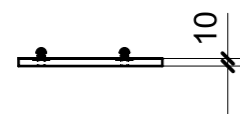
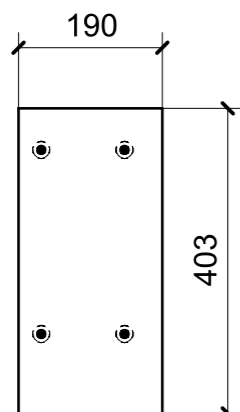

05

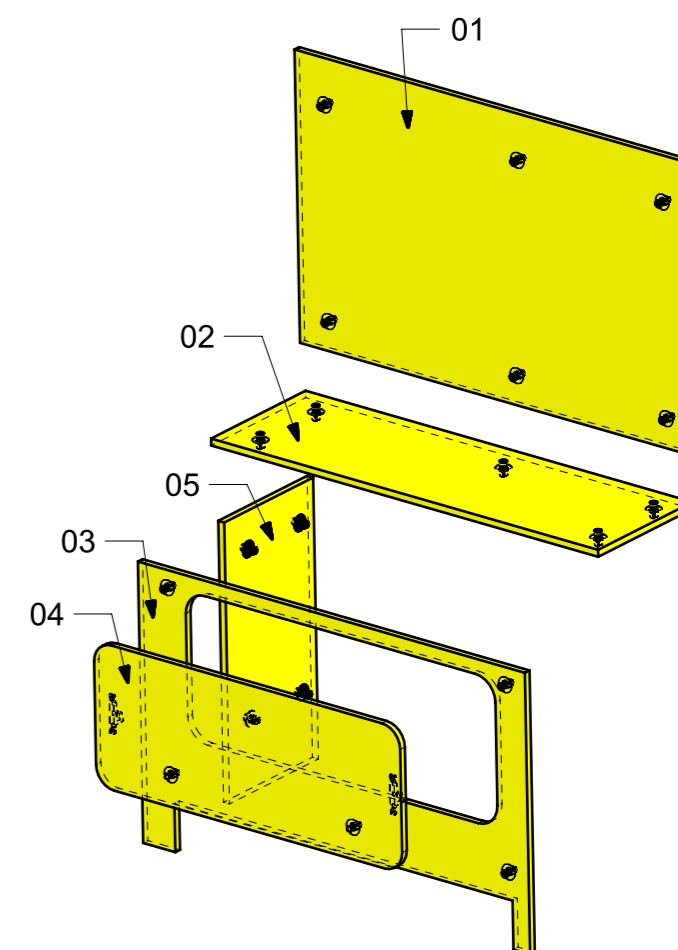

FERRAMENTA	QTY
MS INCASSO_ITALVIPLA_972_FMPC_M1B	20

LOCALE	CODICE	DESCRIZIONE COMPONENTE	FINITURA	Q.TA
SALONE	MD299_I01_SG01	COLLEGAMENTO BASSO DX PRUA	OKUME' GREZZO	1

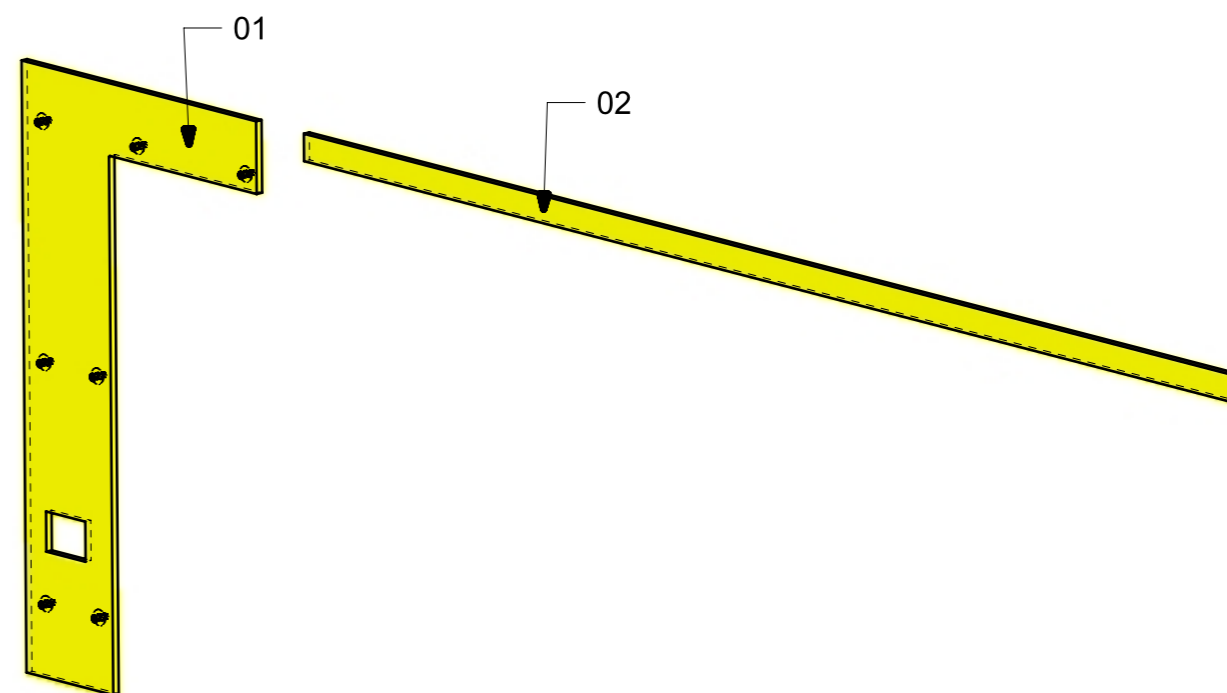
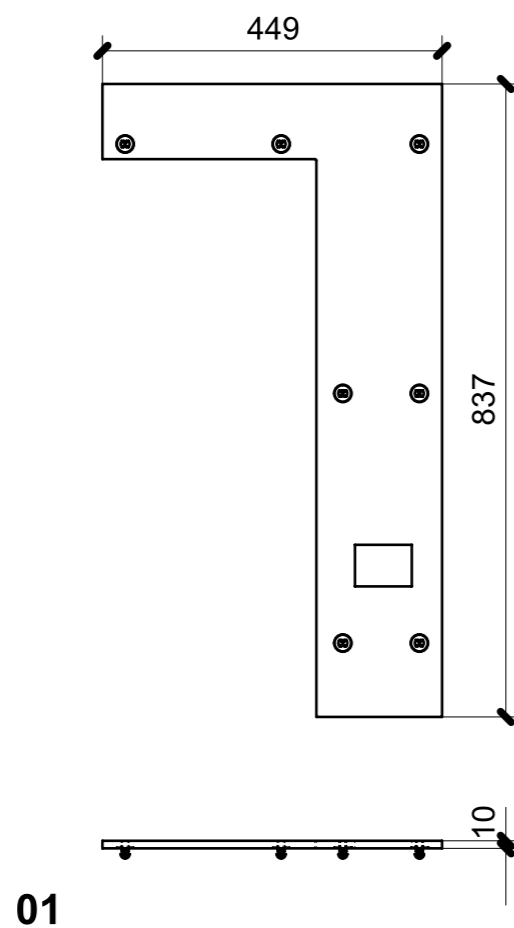

FERRAMENTA	QTY
MS INCASSO_ITALVIPLA_972_FMPC_M1B	7

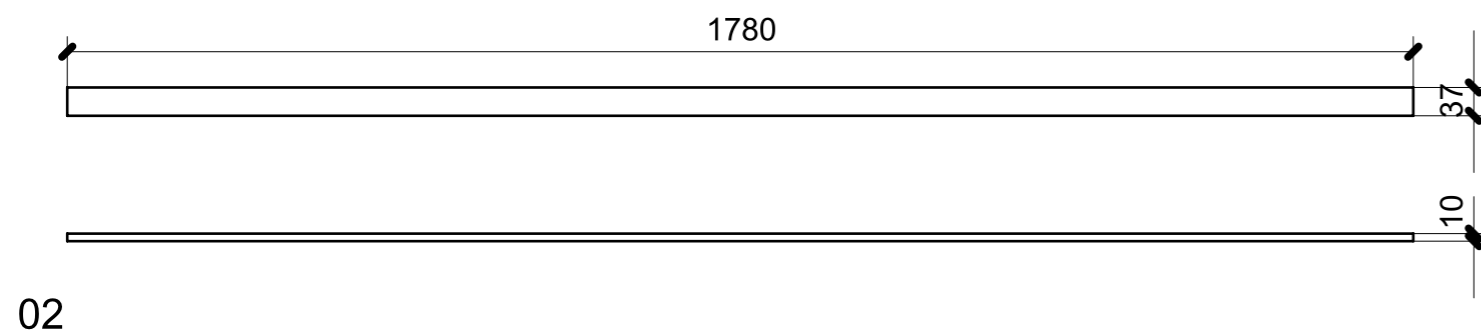

LOCALE	CODICE	DESCRIZIONE COMPONENTE	FINITURA	Q.TA
SALONE	MD299_I01_SI01	COLONNA DX CENTRO	OKUME' GREZZO	1

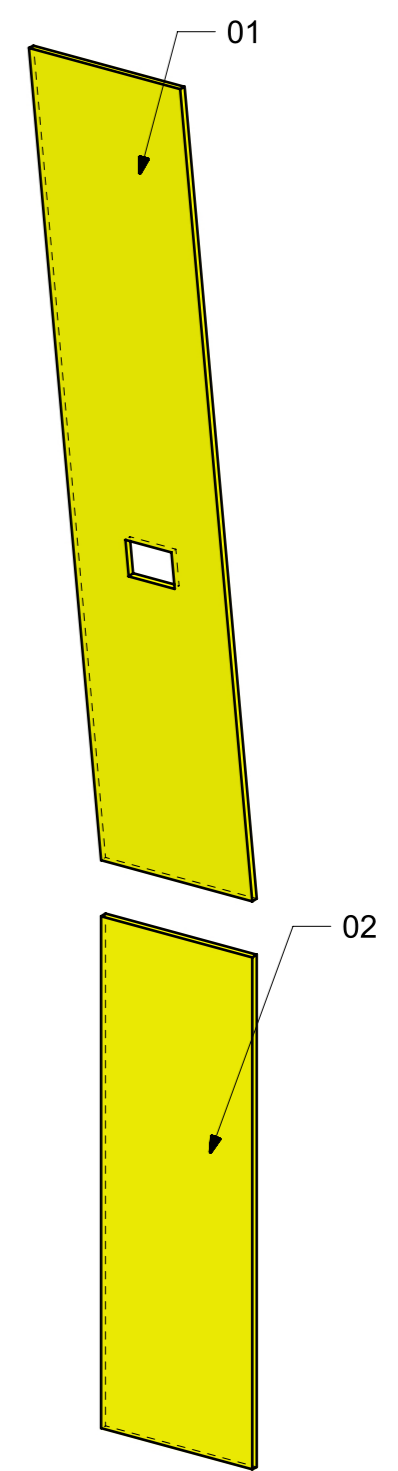
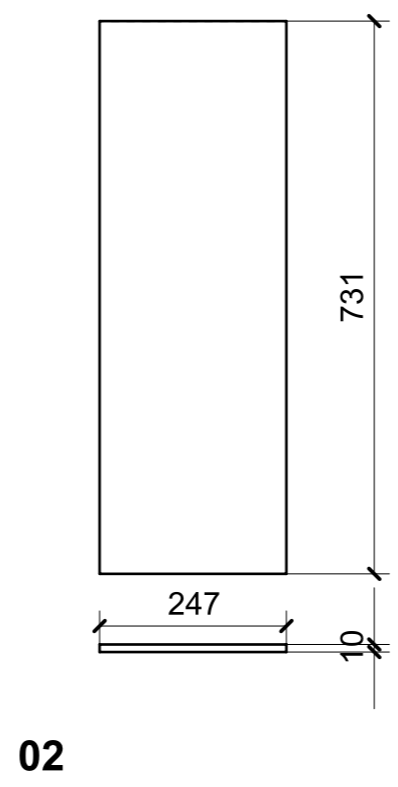
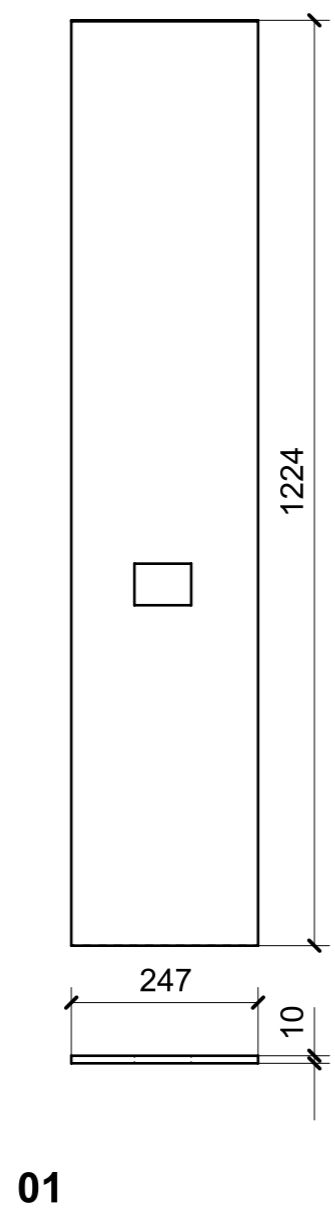

LOCALE	CODICE	DESCRIZIONE COMPONENTE	FINITURA	Q.TA
SALONE	MD299_I01_SJ01	COLONNA DX PRUA	OKUME' GREZZO	1

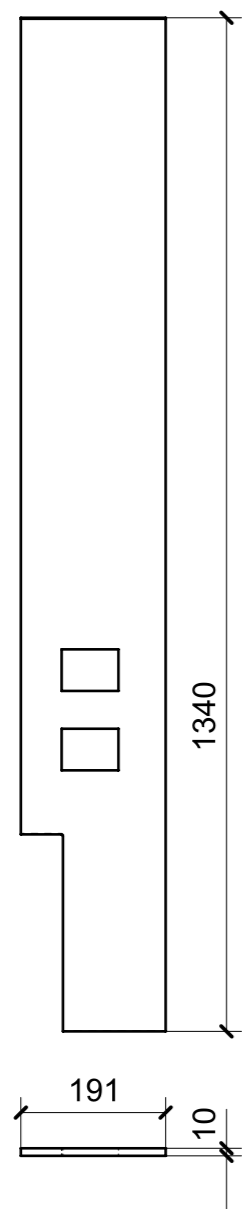

01

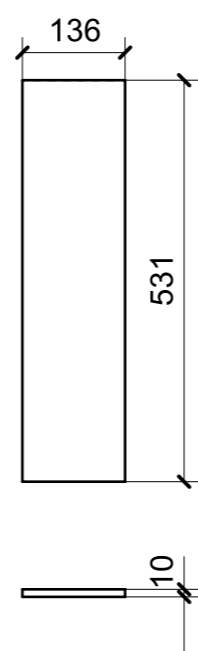

02

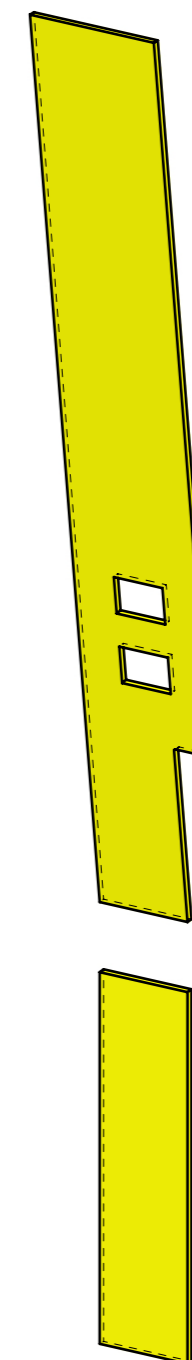

LOCALE	CODICE	DESCRIZIONE COMPONENTE	FINITURA	Q.TA
SALONE	MD299_I01_SL01	COLLEGAMENTO SCHIENALE DINETTE	OKUME' GREZZO	1

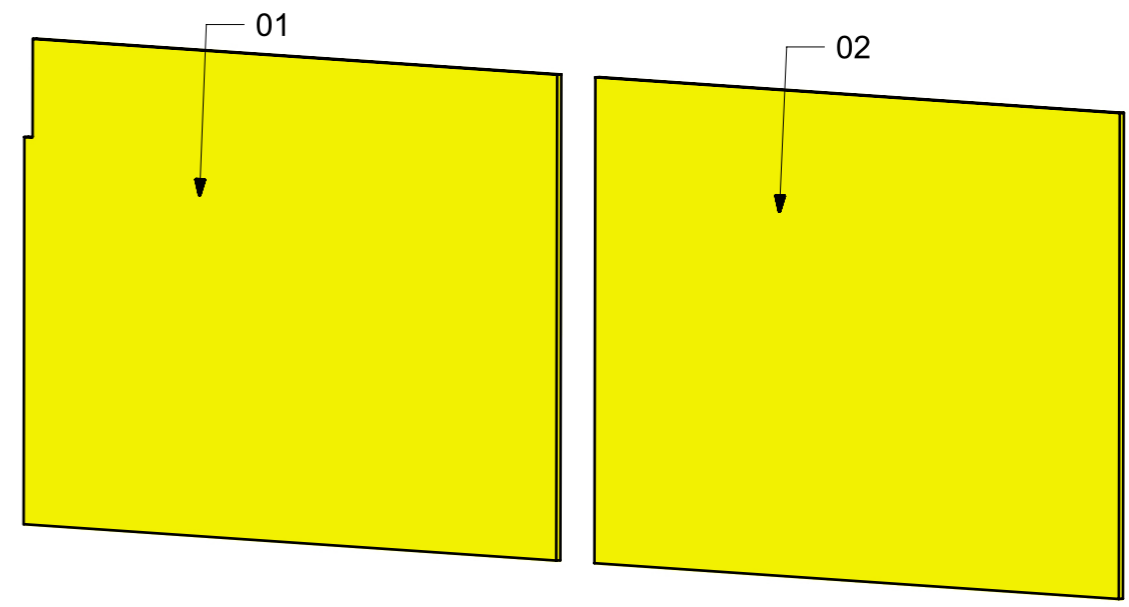
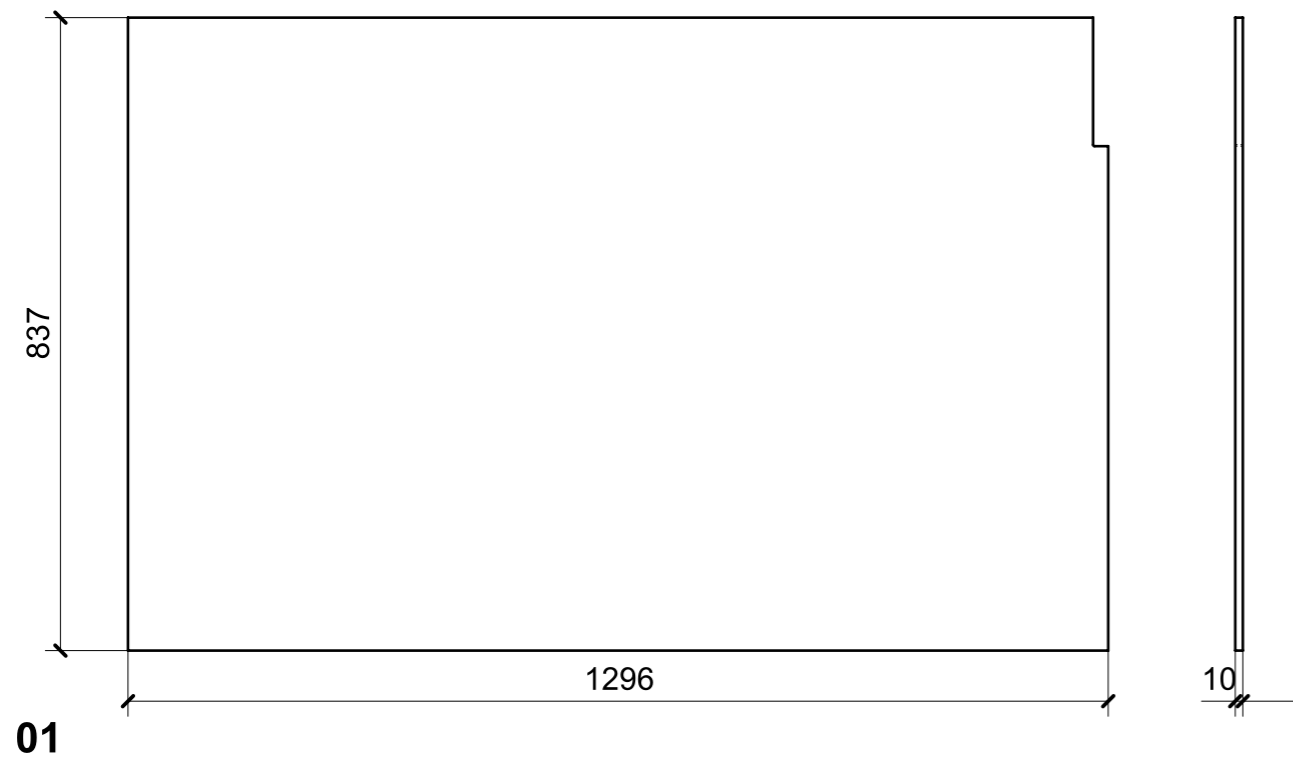

LOCALE	CODICE	DESCRIZIONE COMPONENTE	FINITURA	Q.TA
SALONE	MD299_I01_SM01	COLONNA DX PRUA GUIDA	OKUME' GREZZO	1

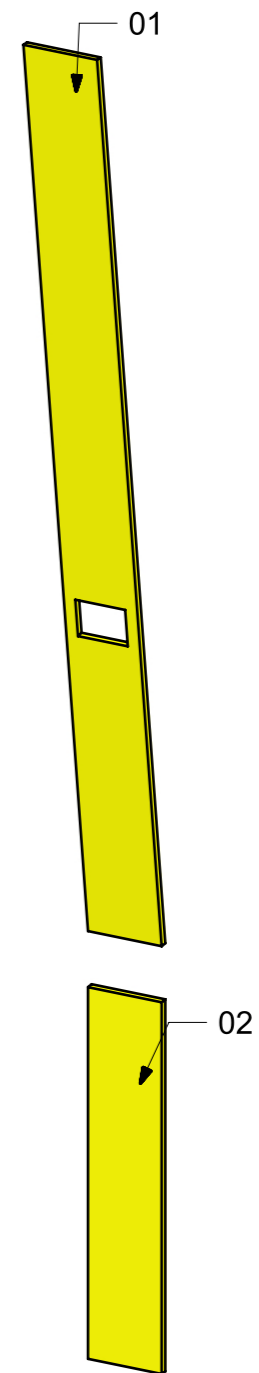
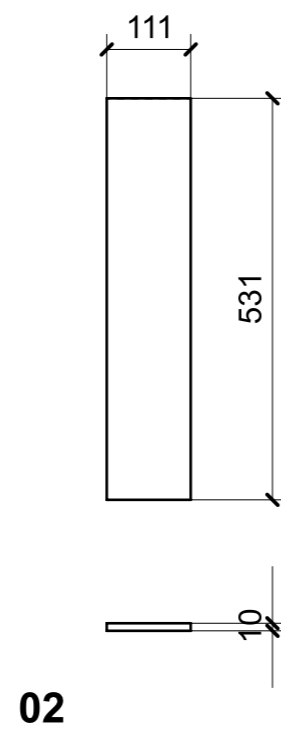
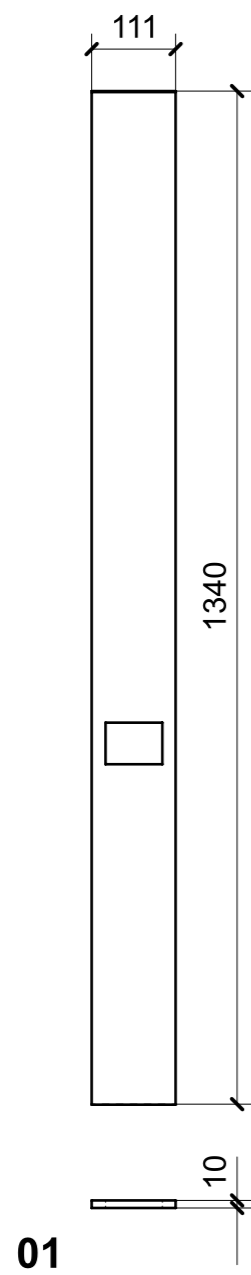

LOCALE	CODICE	DESCRIZIONE COMPONENTE	FINITURA	Q.TA
SALONE	MD299_I01_SP01	CIELINO PLENUM SX CENTRO MURATA	OKUME' GREZZO	1

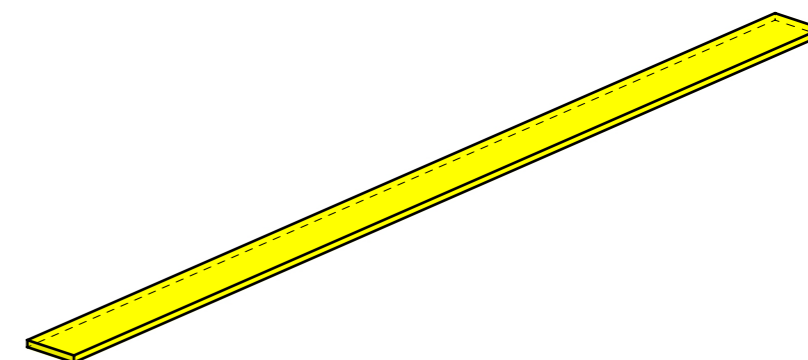
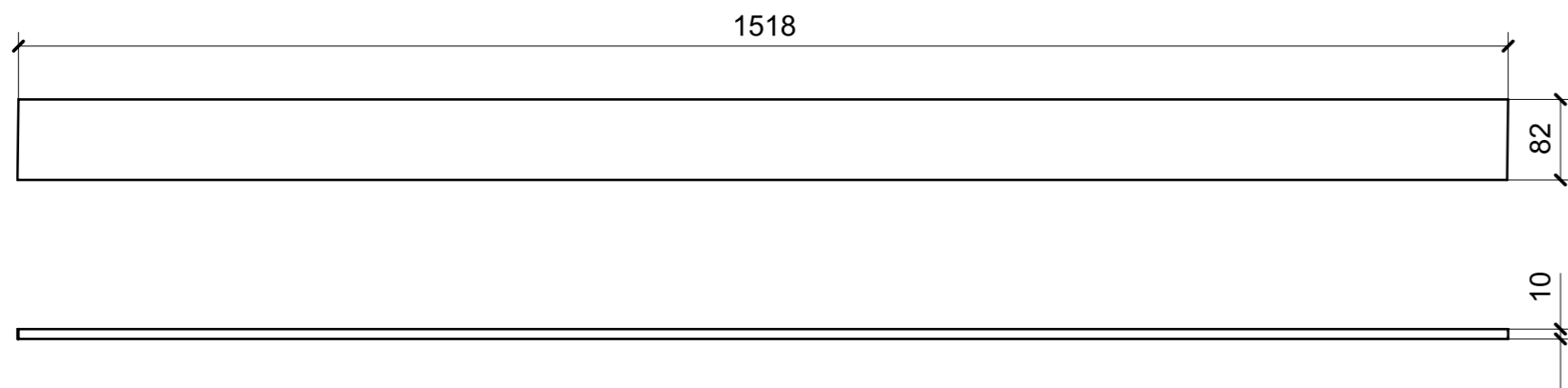

LOCALE	CODICE	DESCRIZIONE COMPONENTE	FINITURA	Q.TA
SALONE	MD299_I01_SQ01	CIELINO PLENUM SX POPPA	OKUME' GREZZO	1

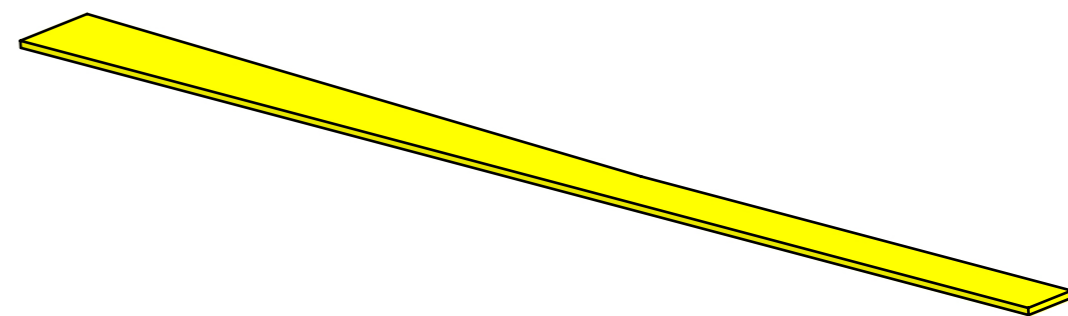
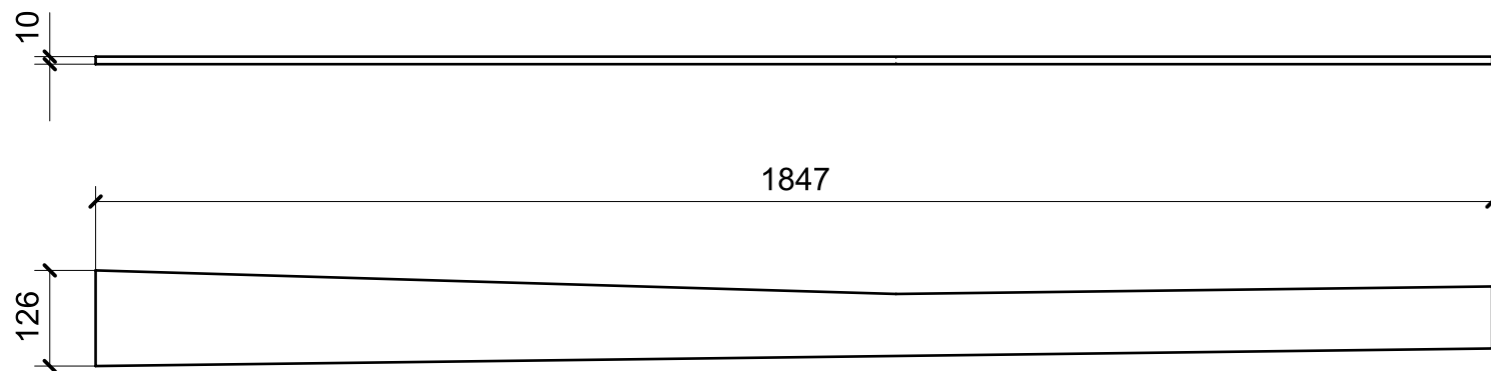

LOCALE	CODICE	DESCRIZIONE COMPONENTE	FINITURA	Q.TA
SALONE	MD299_I01_SR01	TRAVERSA INGRESSO SOFFITTO	OKUME' GREZZO	1

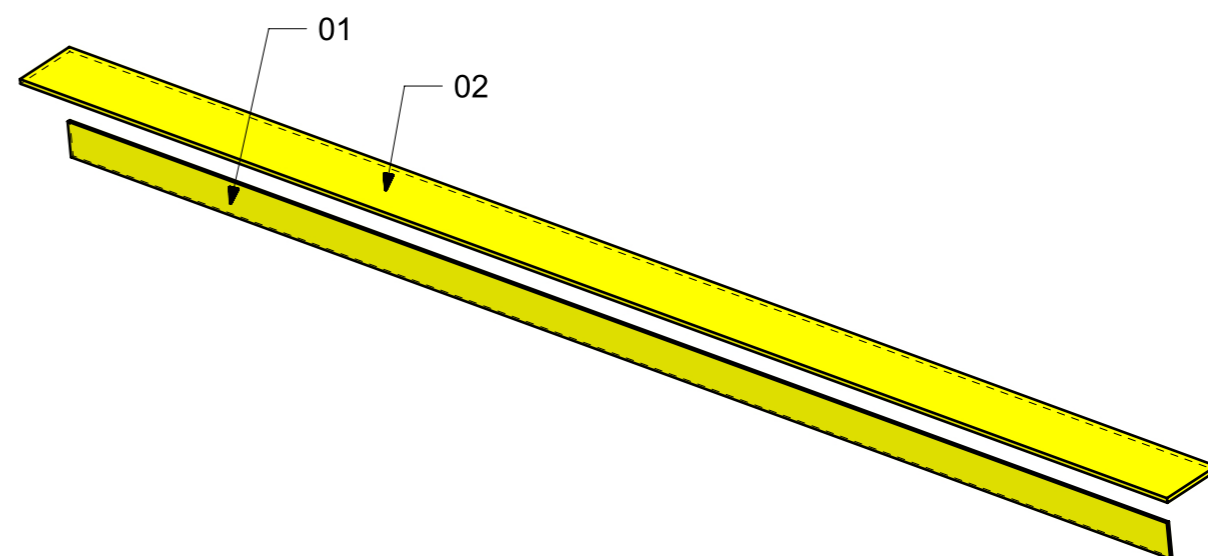
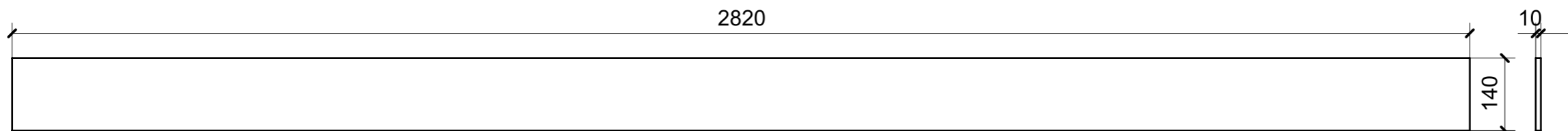
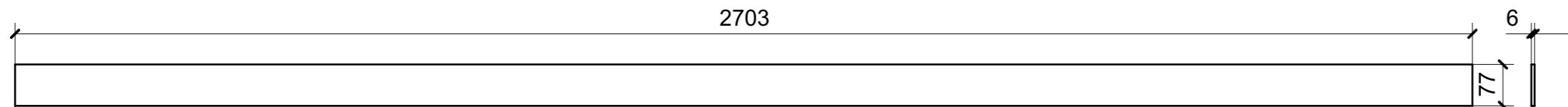

LOCALE	CODICE	DESCRIZIONE COMPONENTE	FINITURA	Q.TA
SALONE	MD299_I01_SS01	CIELINO PLENUM DX POPPA	OKUME' GREZZO	1

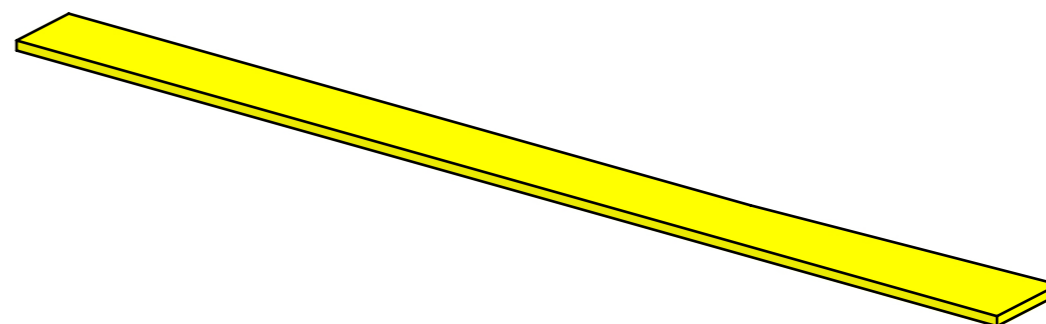
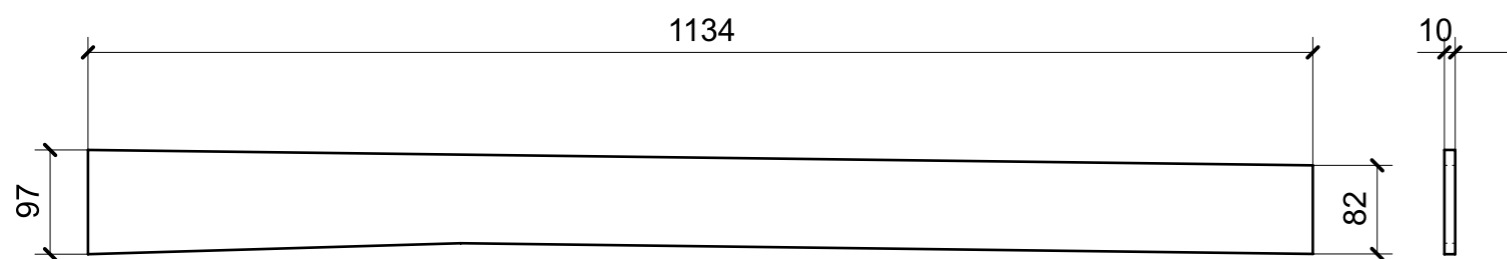

LOCALE	CODICE	DESCRIZIONE COMPONENTE	FINITURA	Q.TA
SALONE	MD299_I01_ST01	CIELINO PLENUM DX CENTRO MURATA	OKUME' GREZZO	1

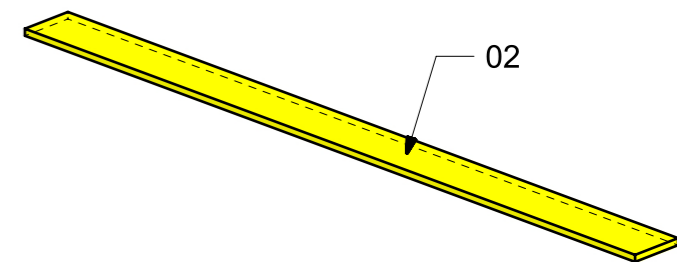
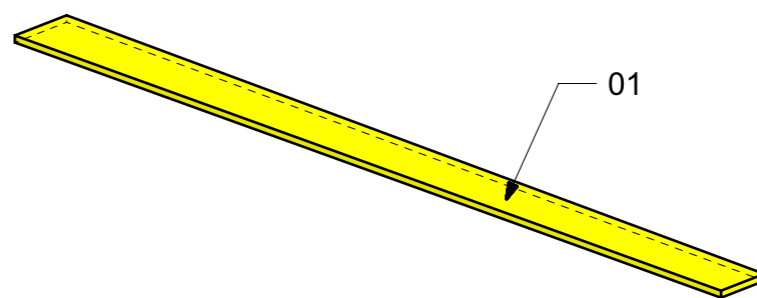
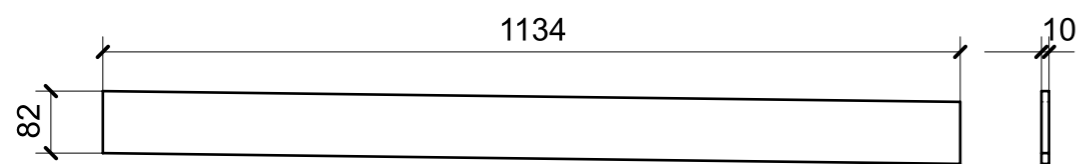
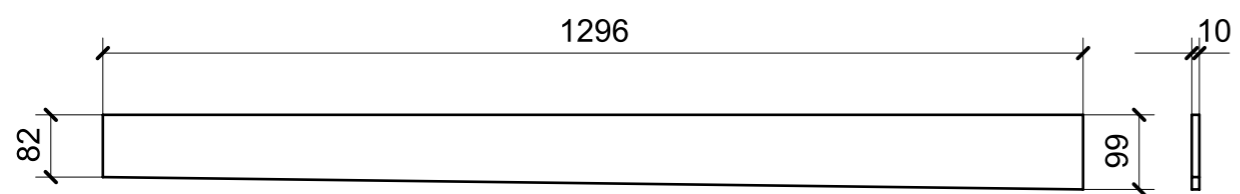

LOCALE	CODICE	DESCRIZIONE COMPONENTE	FINITURA	Q.TA
SALONE	MD299_I01_SW01	CIELINO PLENUM DX PRUA	OKUME' GREZZO	1

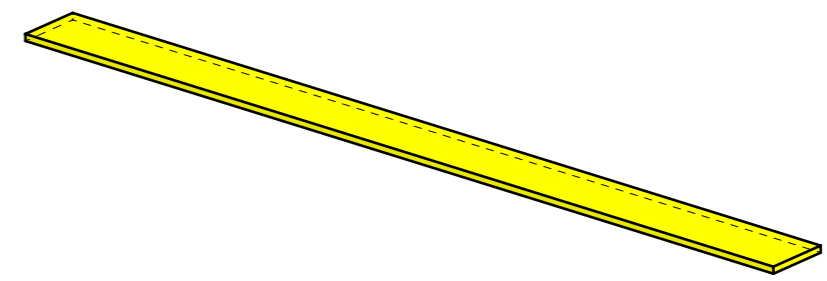
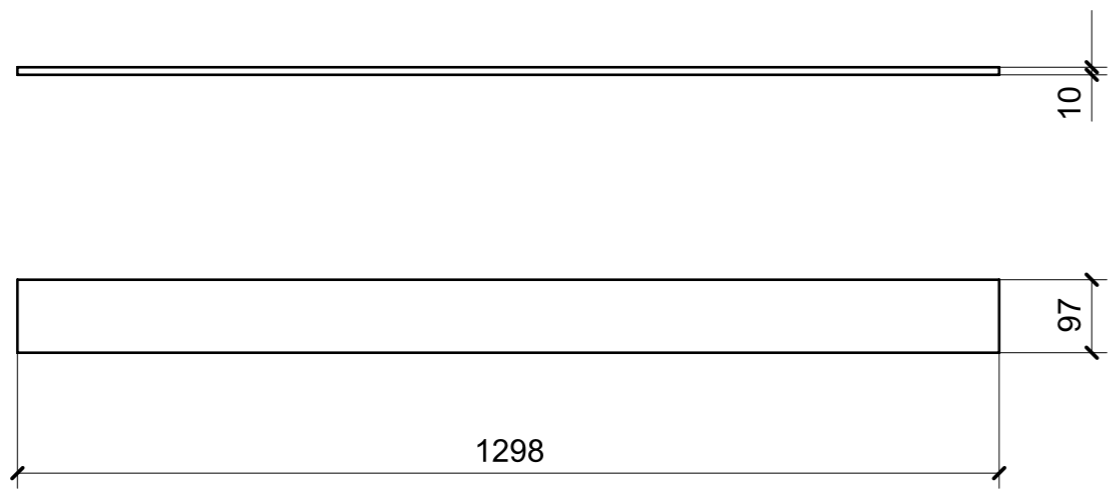

LOCALE	CODICE	DESCRIZIONE COMPONENTE	FINITURA	Q.TA
SALONE	MD299_I01_SX01	CIELINO PLENUM SX PRUA	OKUME' GREZZO	1

