

LOCALE	CODICE	DESCRIZIONE COMPONENTE	FINITURA	Q.TA
BAGNO ARMATORE	MD298_R01_WA01	STRUTTURA MURATA	LASTRA CHIARA	1

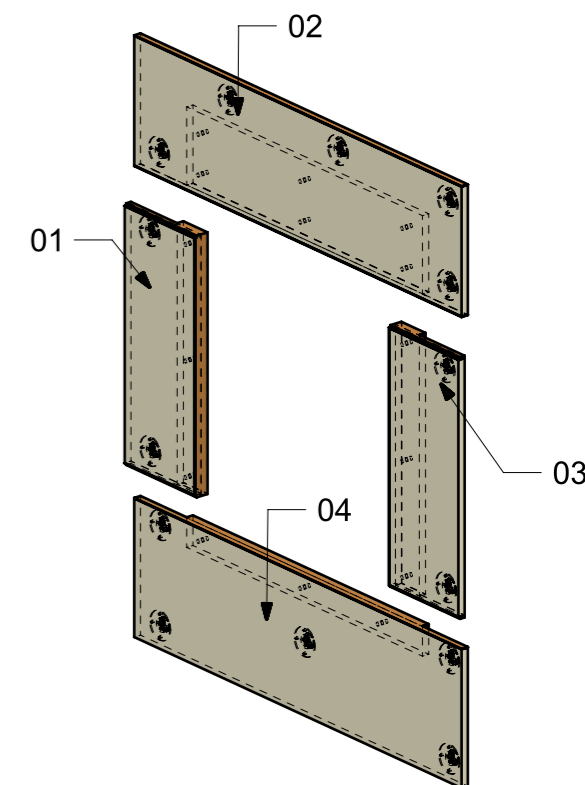
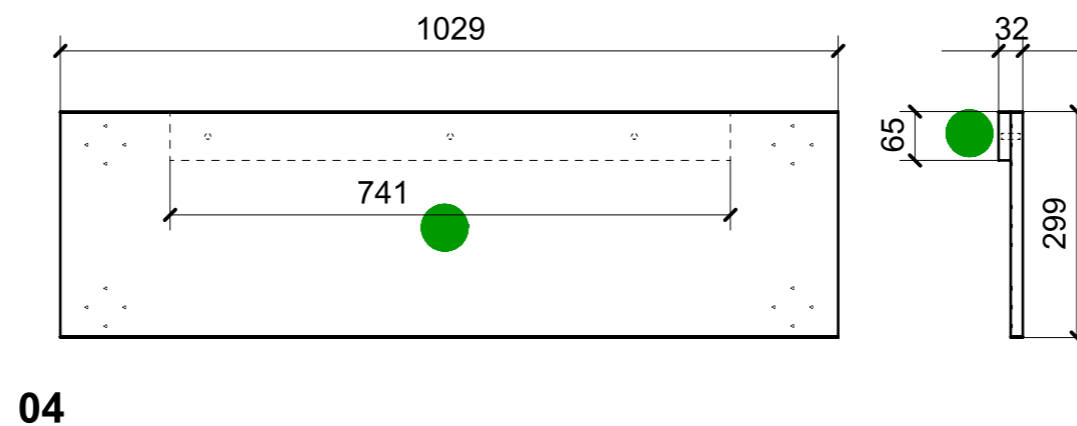
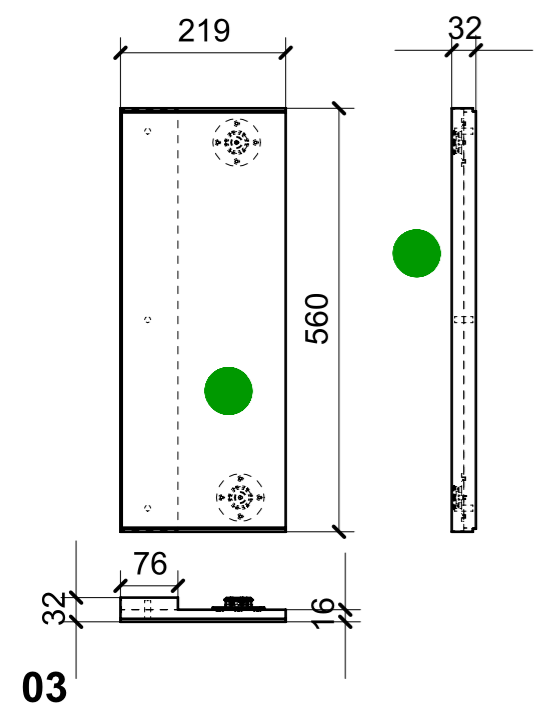
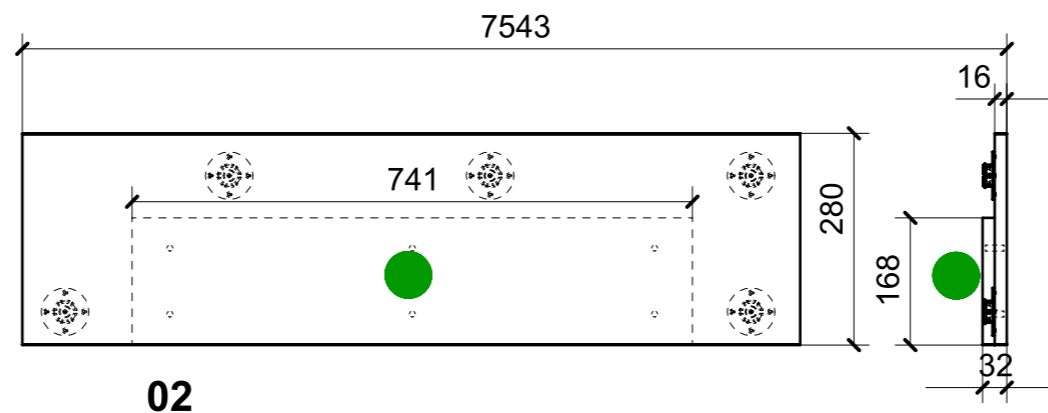
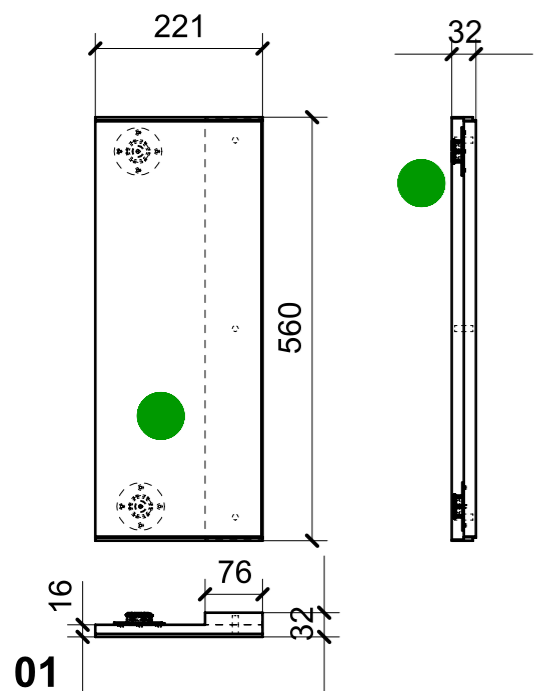

FERRAMENTA	QTY
FITLOCK M_MASCHERPA_3MM_6020202101	14

VERNICIATURA LASTRA/LACCATI:

● = VERNICIARE 1 LATO + FILI RASATI O BORDATI

NESSUN SIMBOLO = VERNICIARE 2 LATI + FILI RASATI O BORDATI

LOCALE	CODICE	DESCRIZIONE COMPONENTE	FINITURA	GR
BAGNO ARMATORE	MD298_R01_WB01	RIV. PARETE DI POPPA	LASTRA CHIARA	8

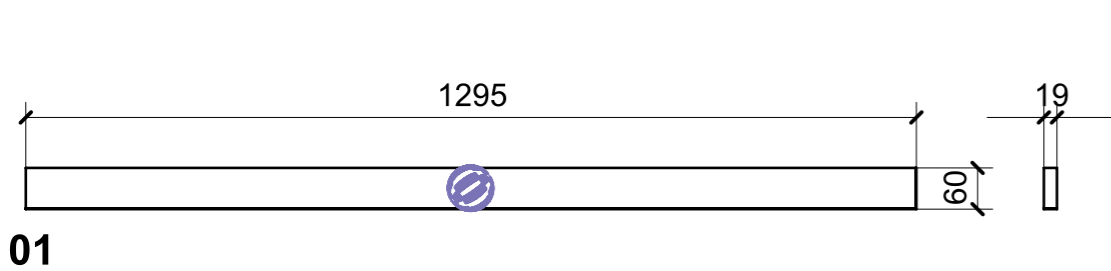

01

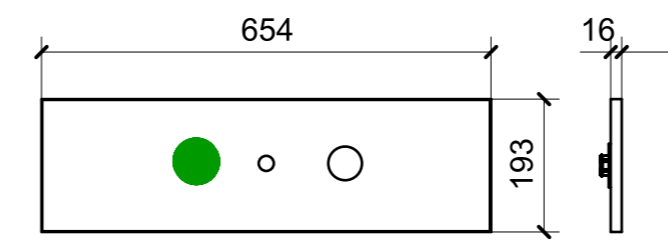

06

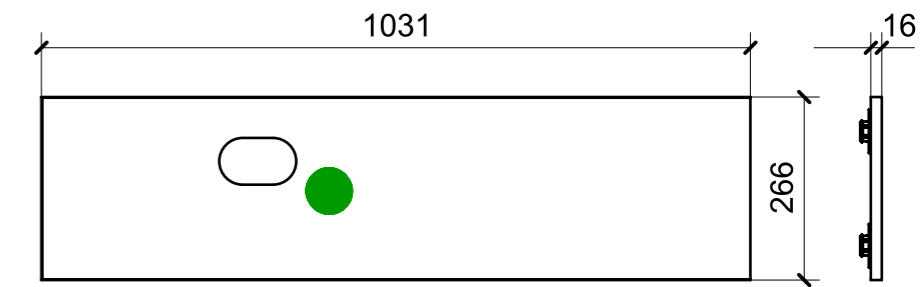

07

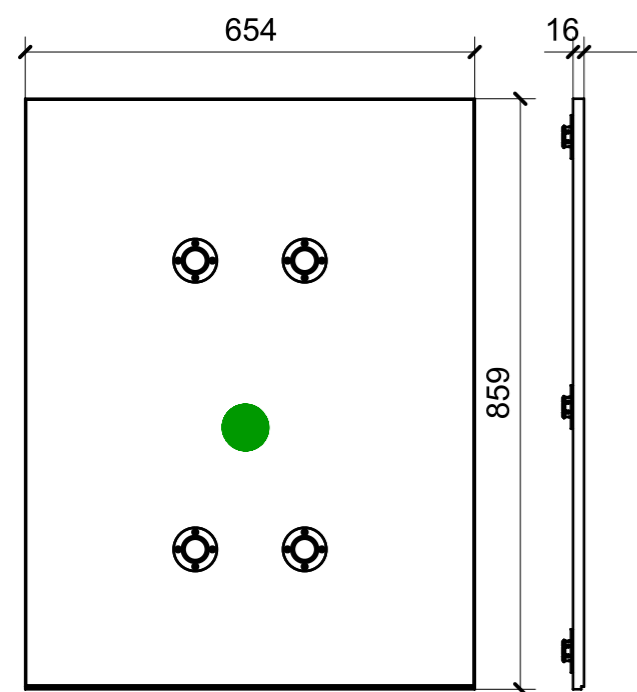

02

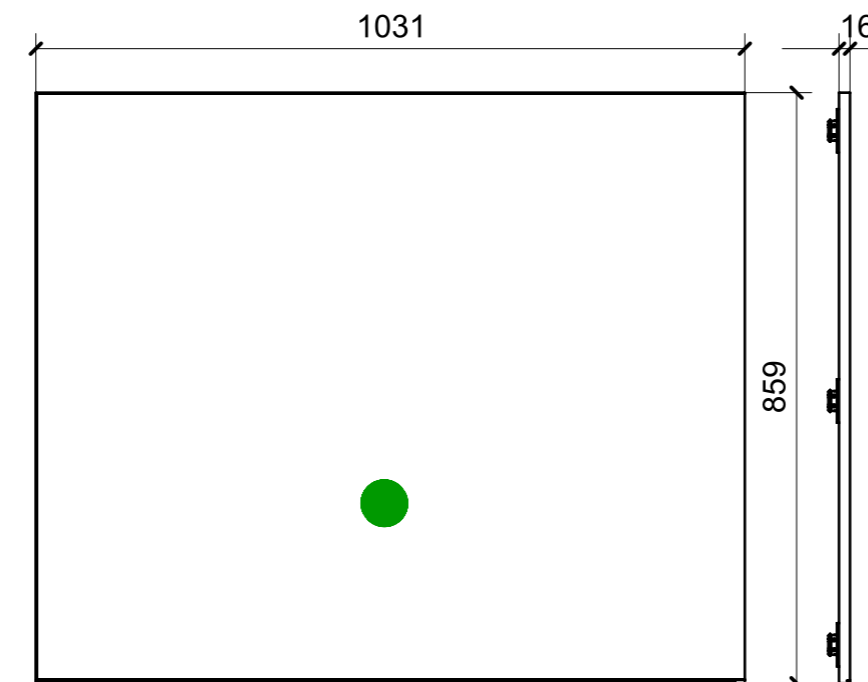

04

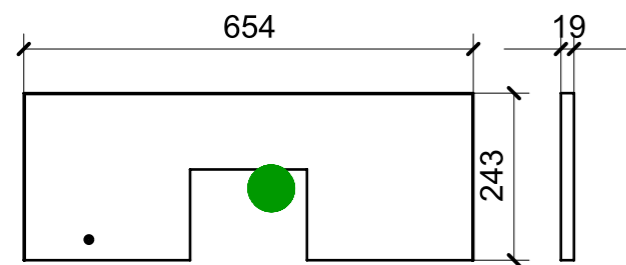
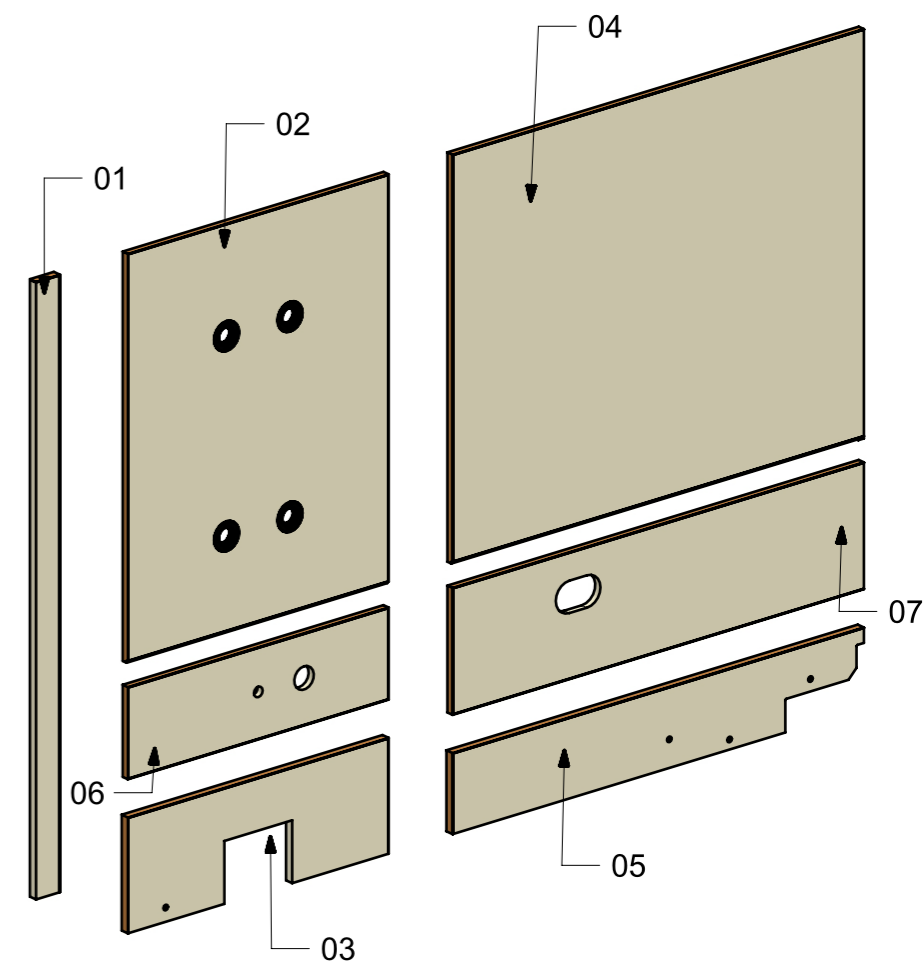

03

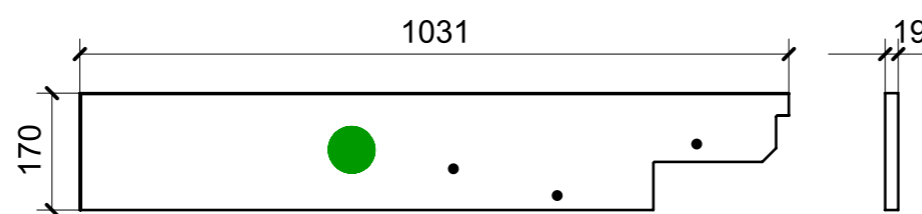

05

FERRAMENTA	QTY
FITLOCK F_MASCHERPA_6020101102	4
FITLOCK M_MASCHERPA_3MM_6020202101	24
BUSSOLA 5MA X 10 FORO DIAM.8	4

VERNICIATURA LASTRA/LACCATI:

● = VERNICIARE 1 LATO + FILI RASATI O BORDATI

NESSUN SIMBOLO = VERNICIARE 2 LATI + FILI RASATI O BORDATI

LOCALE	CODICE	DESCRIZIONE COMPONENTE	FINITURA	GR
BAGNO ARMATORE	MD298_L01_WB01	RIV. PARETE DI POPPA	LACCATO BIANCO PERLA RAL 1013	8

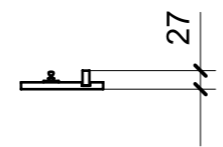
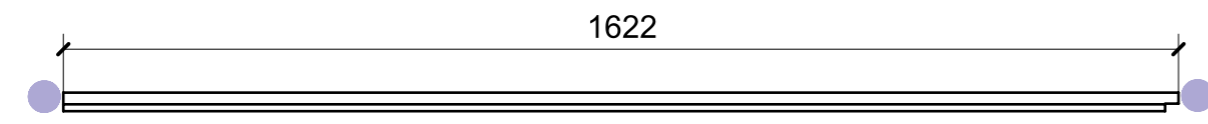
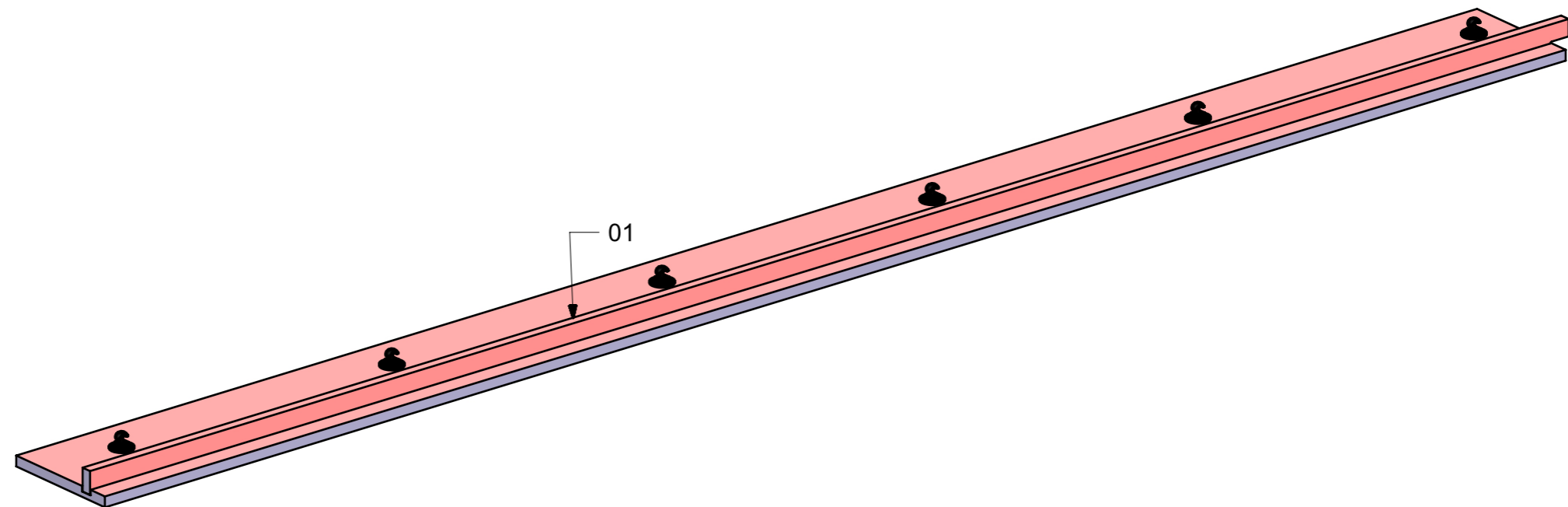

FERRAMENTA	QTY
MS INCASSO_ITALVIPLA_972_FMPC_M1B	6

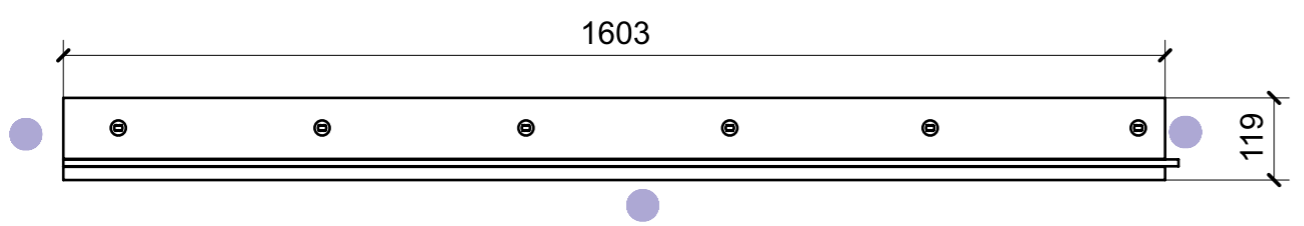

● = FILI RASATI

● = VERNICIARE 1 LATO + FILI RASATI O BORDATI

NESSUN SIMBOLO = VERNICIARE 2 LATI + FILI RASATI O BORDATI

LOCALE	CODICE	DESCRIZIONE COMPONENTE	FINITURA	GR
BAGNO ARMATORE	MD298_L01_WC01	PLENUM	LACCATO BIANCO PERLA RAL 1013	8

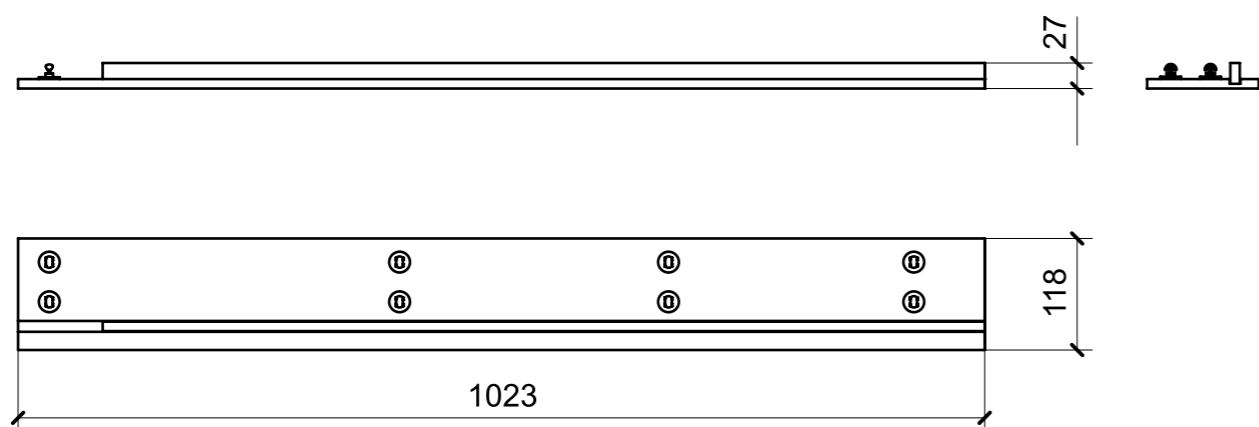
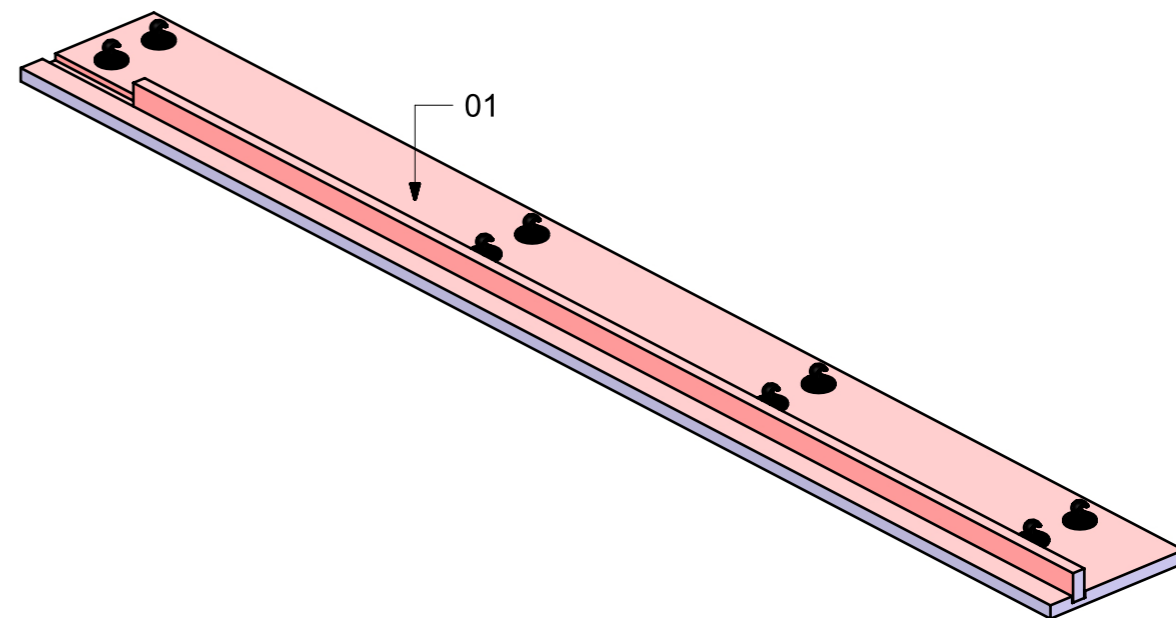

FERRAMENTA	QTY
MS INCASSO_ITALVIPLA_972_FMPC_M1B	8

VERNICIATURA LASTRA/LACCATI:

● = VERNICIARE 1 LATO + FILI RASATI O BORDATI

NESSUN SIMBOLO = VERNICIARE 2 LATI + FILI RASATI O BORDATI

LOCALE	CODICE	DESCRIZIONE COMPONENTE	FINITURA	Q.TA
BAGNO ARMATORE	MD298_MF_WF01	SPECCHIO		1

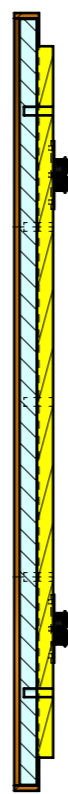
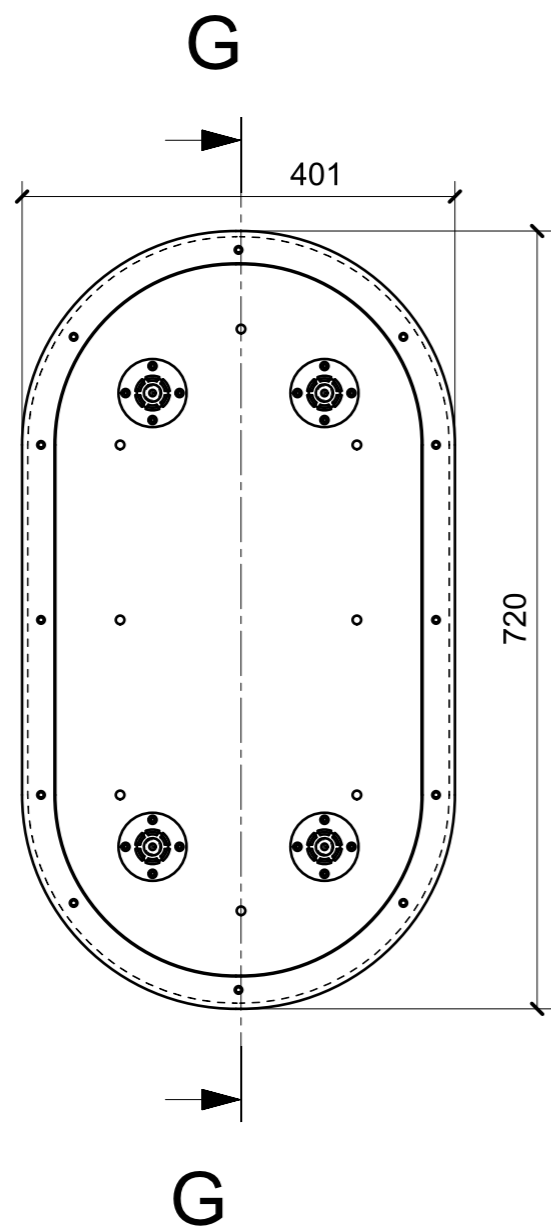

SECTION G-G

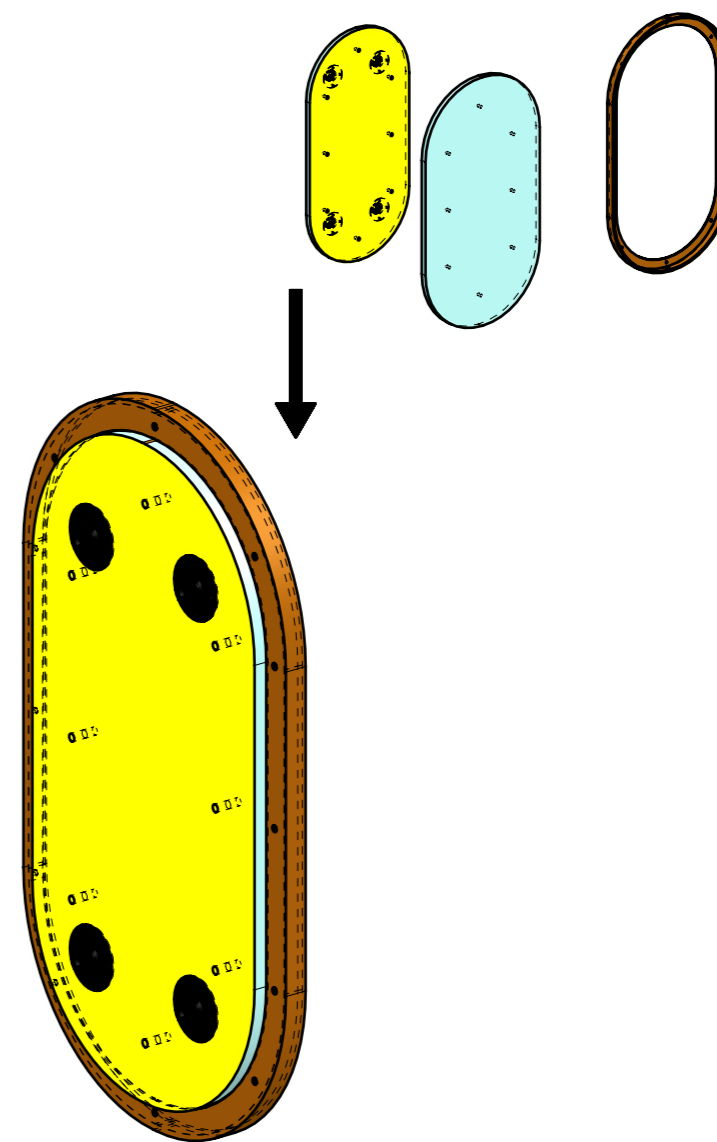

FERRAMENTA	QTY
FITLOCK M_MASCHERPA_3MM_6020202101	4

LOCALE	CODICE	DESCRIZIONE COMPONENTE	FINITURA	Q.TA
BAGNO ARMATORE	MD298_WF01	SPECCHIO	GREZZO SPRUZZATO NERO	1

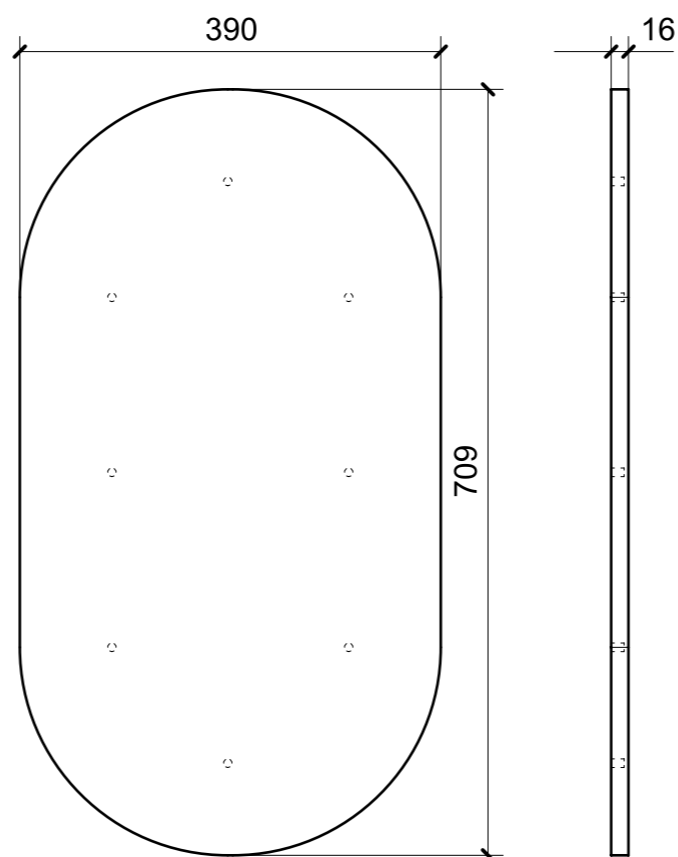
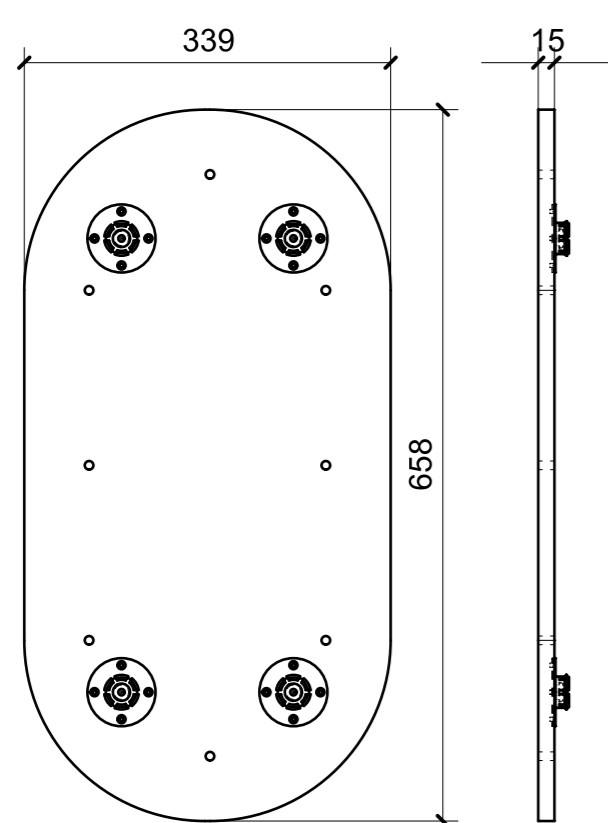

ELEMENTI DA MONTARE
con A03_WF01 in MF_WF01
e spedire con unico imballo

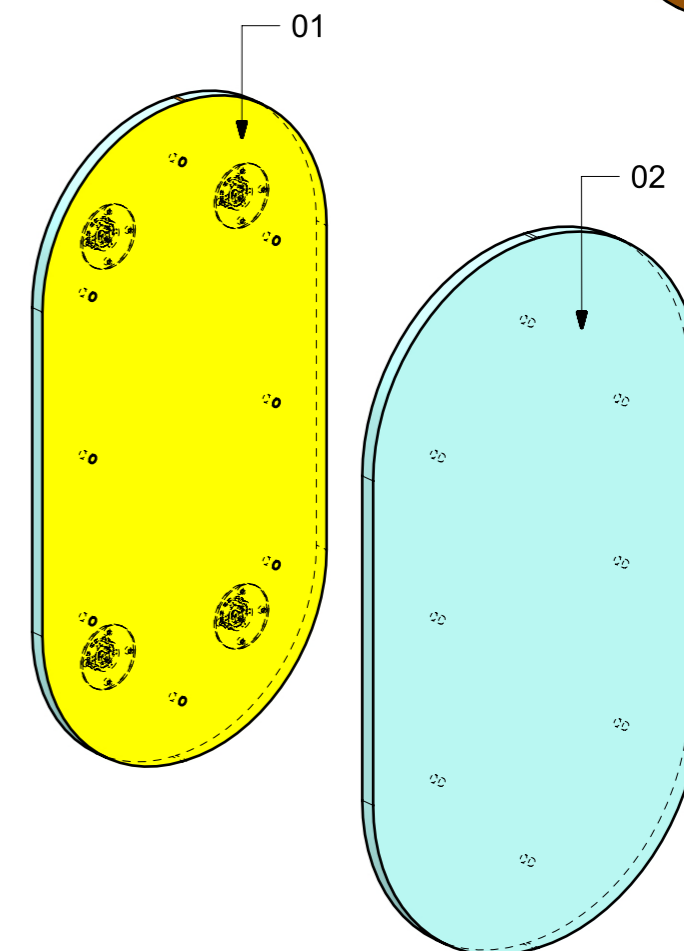
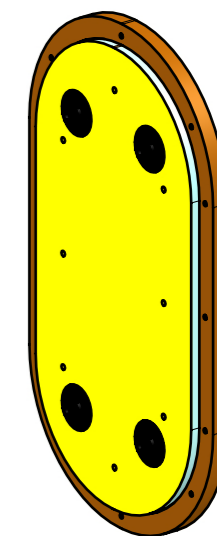

FERRAMENTA	QTY
FITLOCK M_MASCHERPA_3MM_6020202101	4

LOCALE	CODICE	DESCRIZIONE COMPONENTE	FINITURA	Q.TA
BAGNO ARMATORE	MD298_A01_WF01	SPECCHIO	ALLUMINIO VERNICIATO serie 90MFY-01.02	1

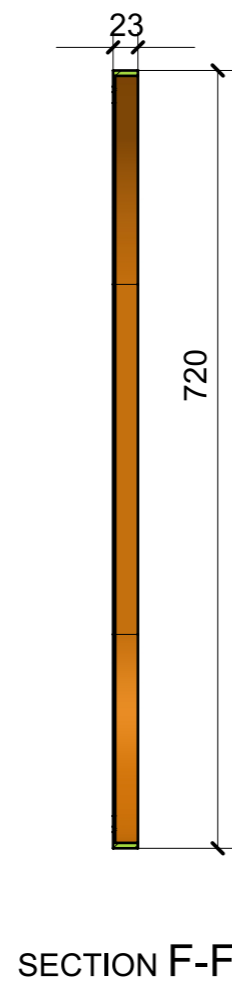
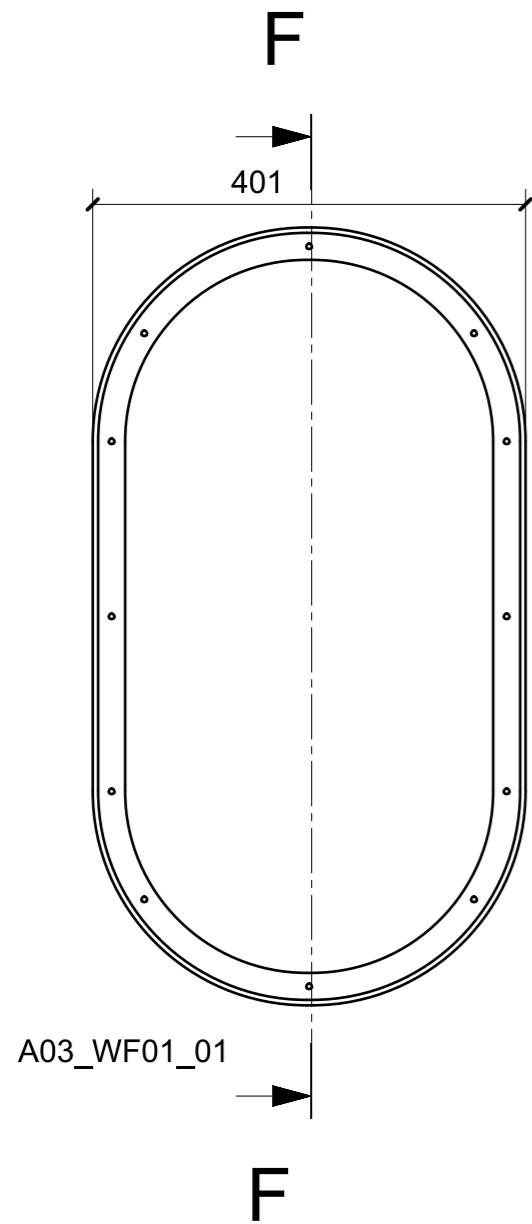

A03_WF01_01

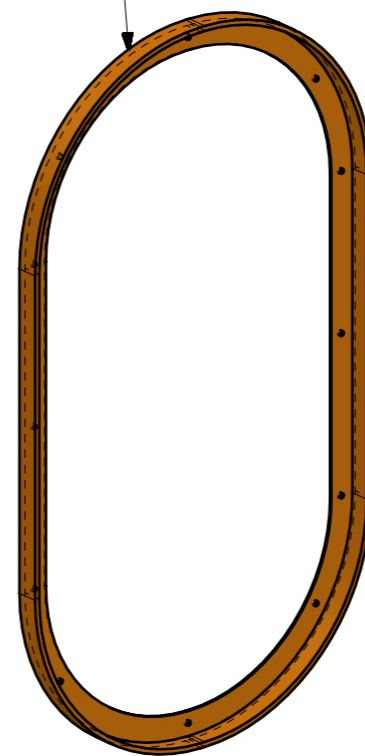

ELEMENTO DA MONTARE
con WF01_01/02 in MF_WF01
e spedire con unico imballo

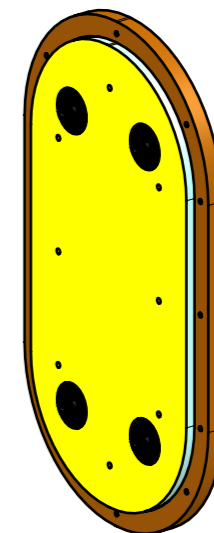

LOCALE	CODICE	DESCRIZIONE COMPONENTE	FINITURA	GR
BAGNO ARMATORE	MD298_L01_WG01	CIELINO INGRESSO	LACCATO BIANCO PERLA RAL 1013	8

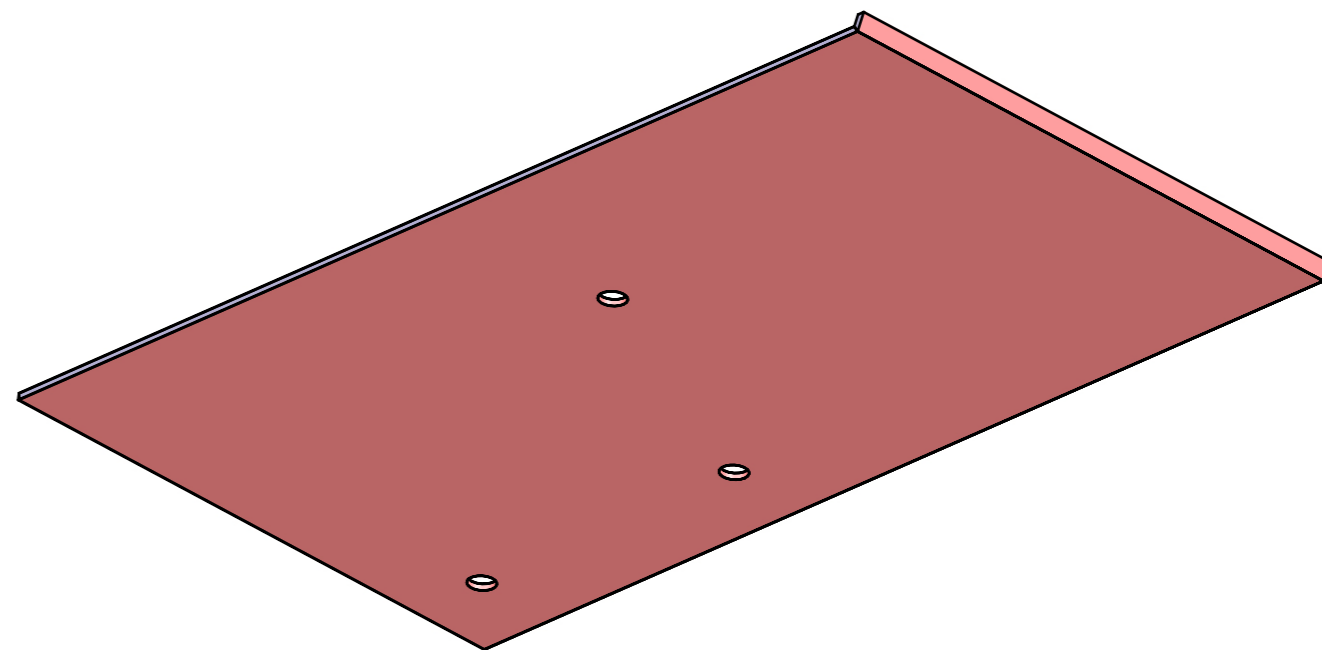
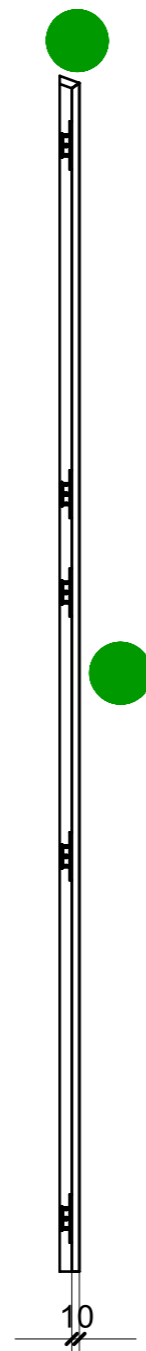
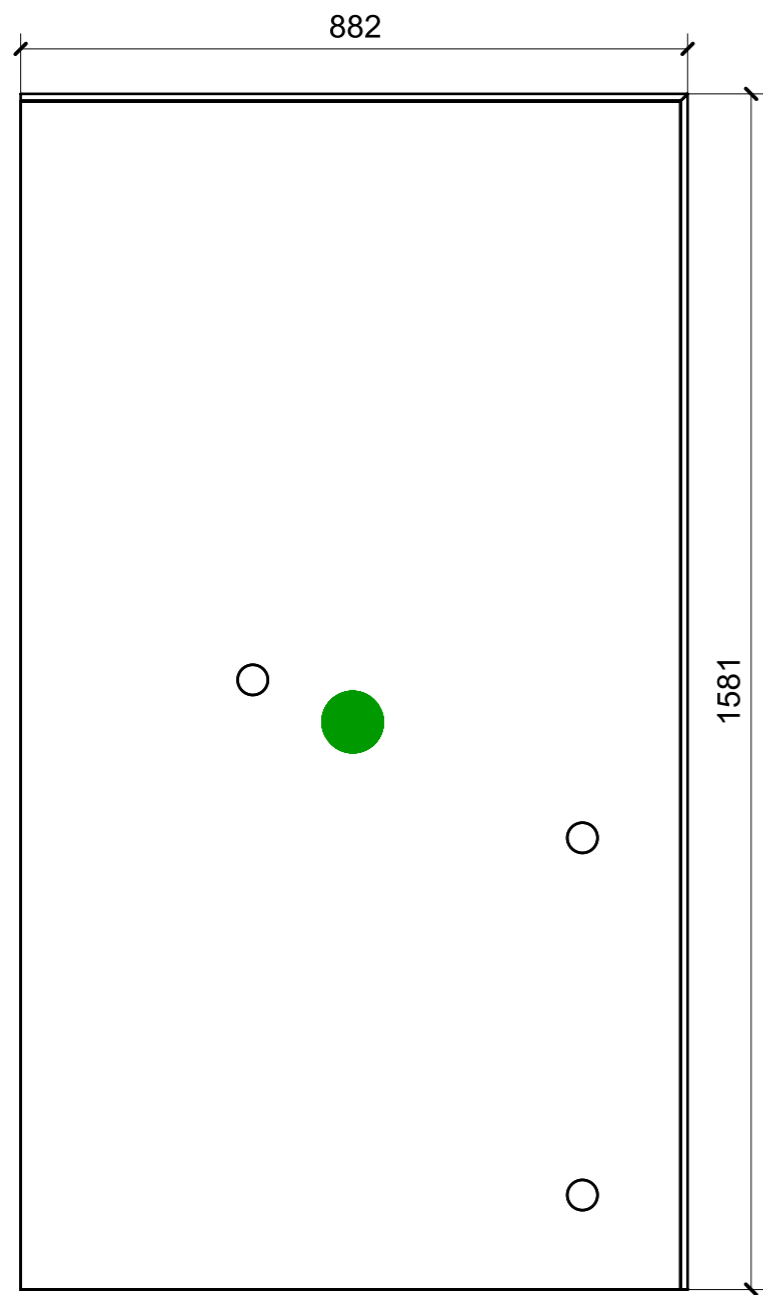

FERRAMENTA	QTY
FITLOCK M_MASCHERPA_3MM_6020202101	12

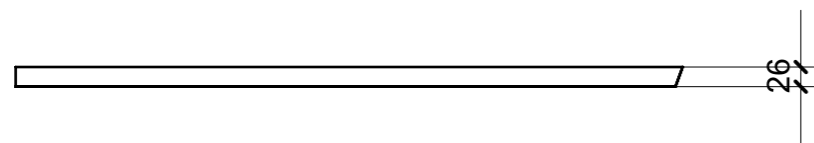

VERNICIATURA LASTRA/LACCATI:

● = VERNICIARE 1 LATO + FILI RASATI O BORDATI

NESSUN SIMBOLO = VERNICIARE 2 LATI + FILI RASATI O BORDATI

LOCALE	CODICE	DESCRIZIONE COMPONENTE	FINITURA	GR
BAGNO ARMATORE	MD298_L01_WH01	CIELINO DOCCIA	LACCATO BIANCO PERLA RAL 1013	8

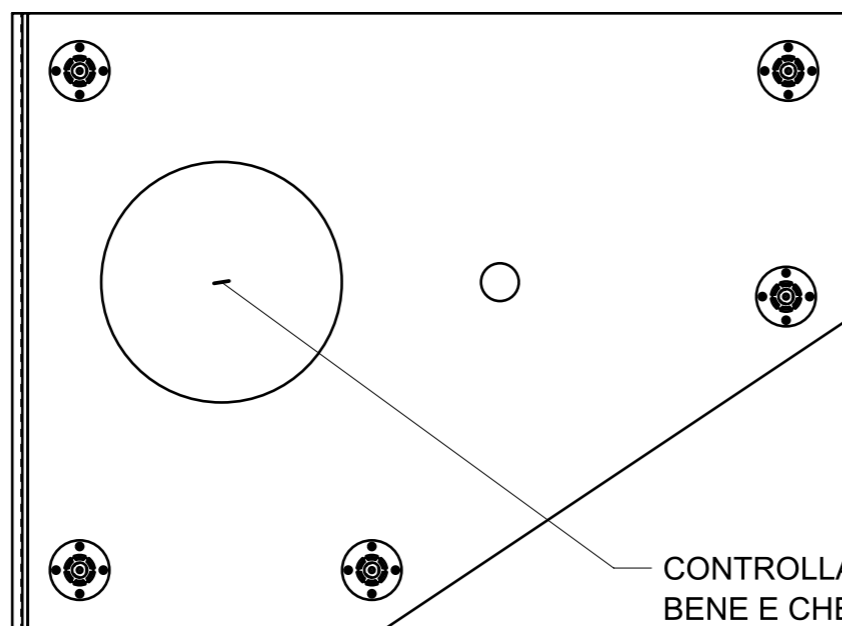
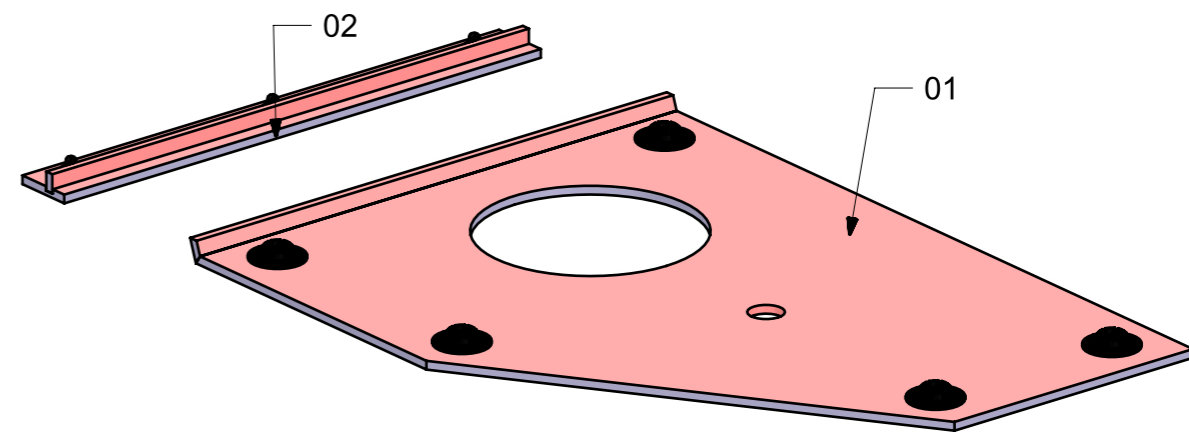
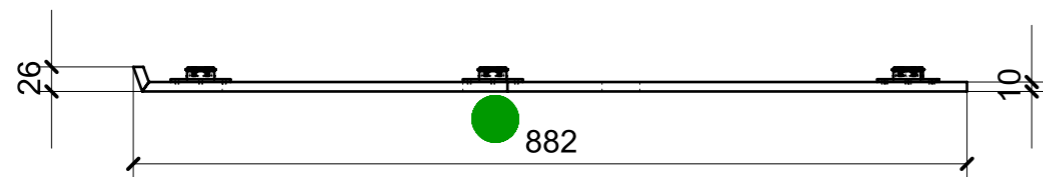

01

FERRAMENTA	QTY
FITLOCK M_MASCHERPA_3MM_6020202101	5
MS INCASSO_ITALVIPLA_972_FMPC_M1B	3

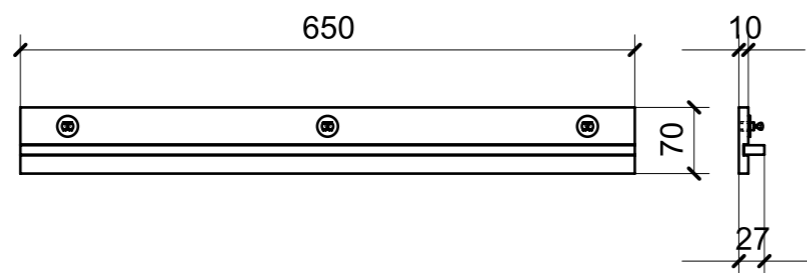

02

VERNICIATURA LASTRA/LACCATI:

● = VERNICIARE 1 LATO + FILI RASATI O BORDATI

NESSUN SIMBOLO = VERNICIARE 2 LATI + FILI RASATI O BORDATI