

LOCALE	CODICE	DESCRIZIONE COMPONENTE	FINITURA	GR.
TIMONERIA	MD320_TA01	MOBILE QUADRI ELETTRICI	LAMINATO SMART 0180-2 JUNGLE	2

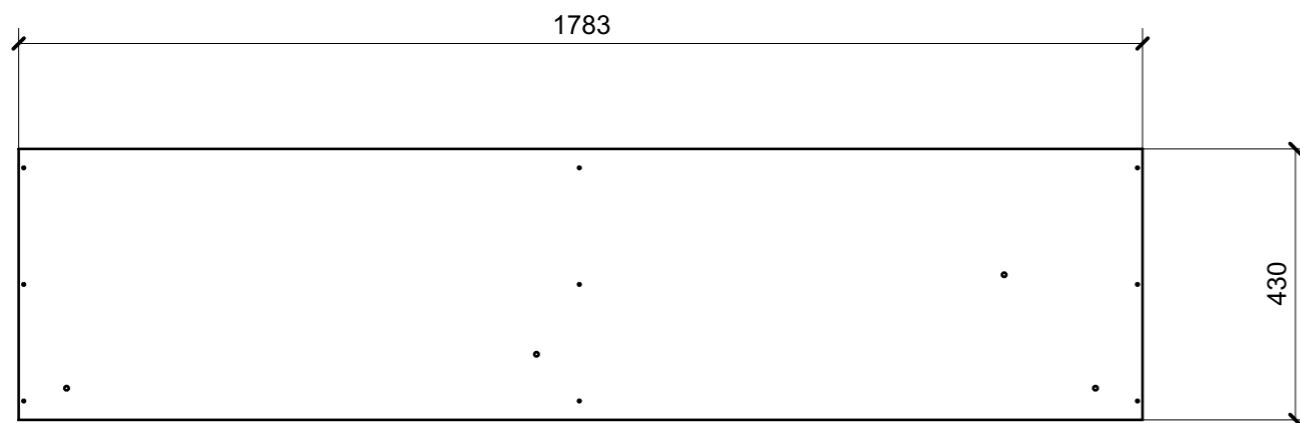

01

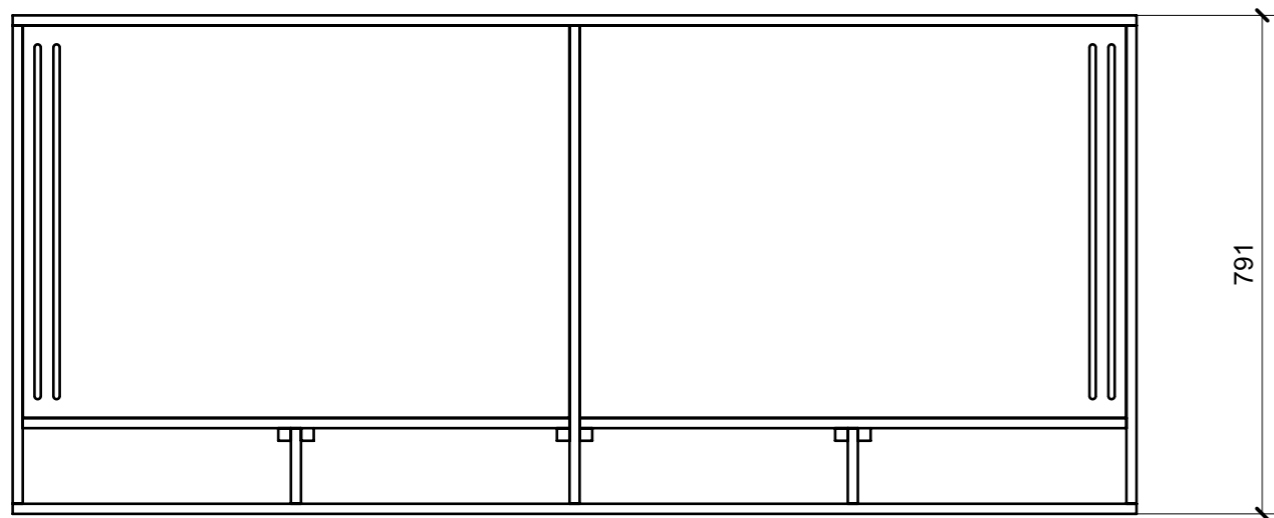
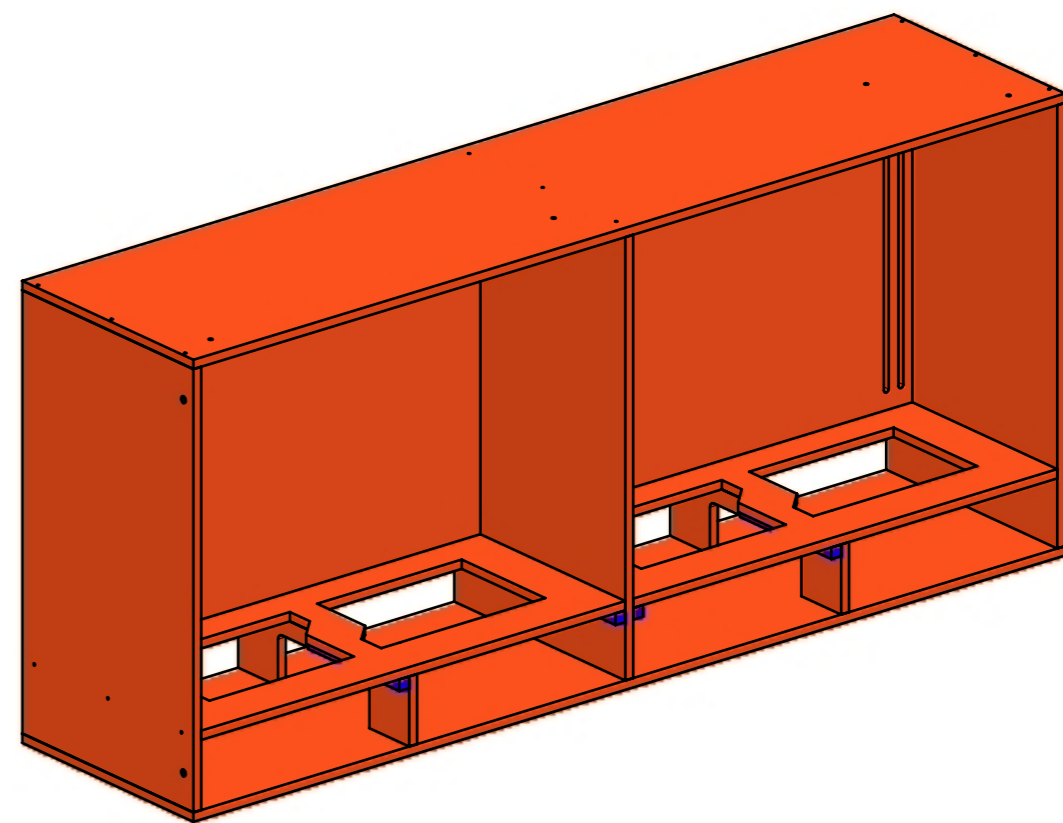

FERRAMENTA	QTY
BUSSOLA 6MAX 10 FORO DIAM.8	4

LOCALE	CODICE	DESCRIZIONE COMPONENTE	FINITURA	GR.
TIMONERIA	MD320_TB01	PLENUM MOBILE QUADRI ELETTRICI	GREZZO VERNICIATO ANTI ROMBO	PTP

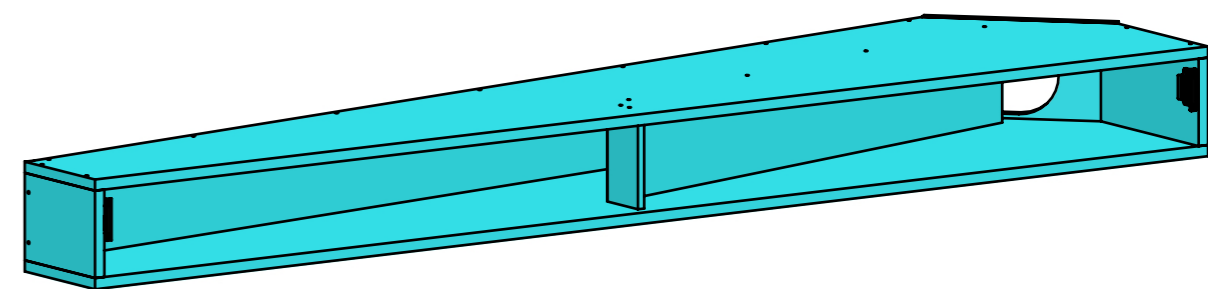
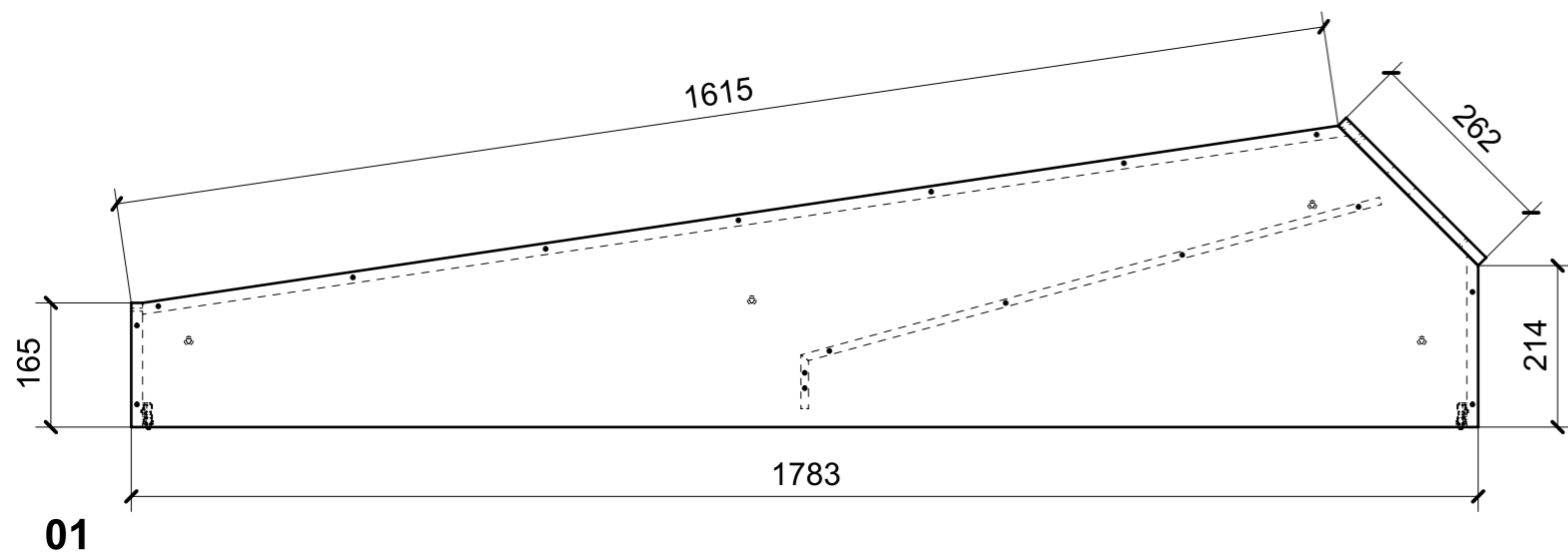
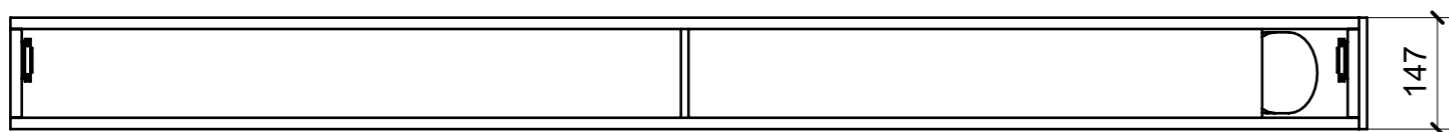

FERRAMENTA	QTY
CHIUSURA A SPINTA_TECHNOPARTNER_SOU C3-203	2
BUSSOLA 6MA X 10 FORO DIAM.8	4

LOCALE	CODICE	DESCRIZIONE COMPONENTE	FINITURA	GR.
TIMONERIA	MD320_TC01	STRUTTURA SX LATERALE QUADRI	OKUME' GREZZO	2

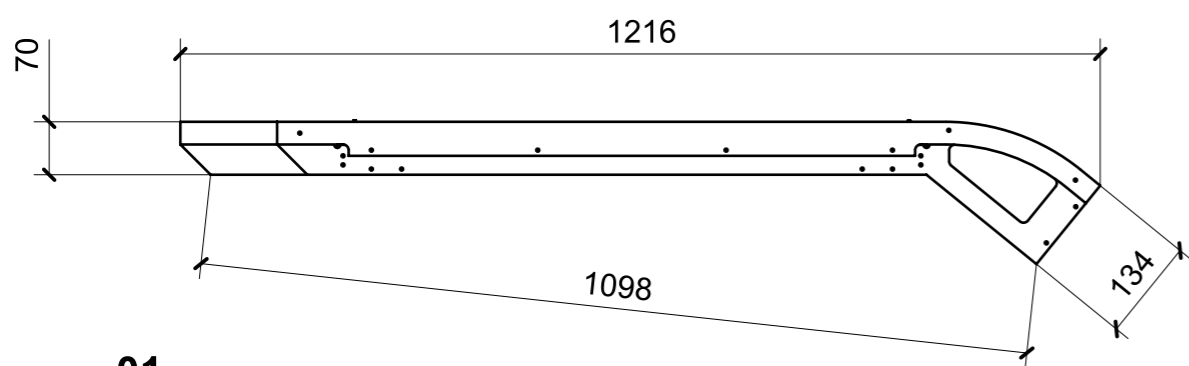
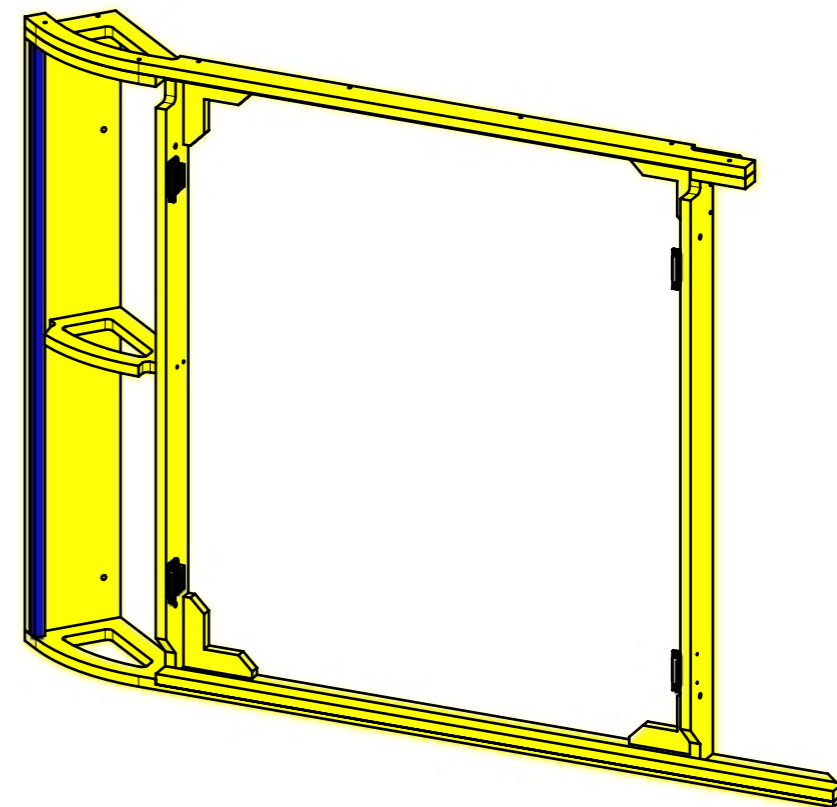
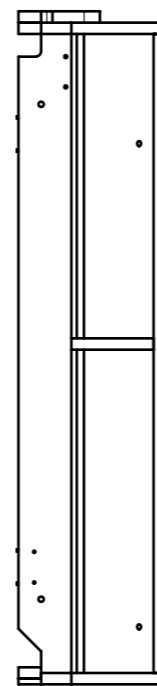
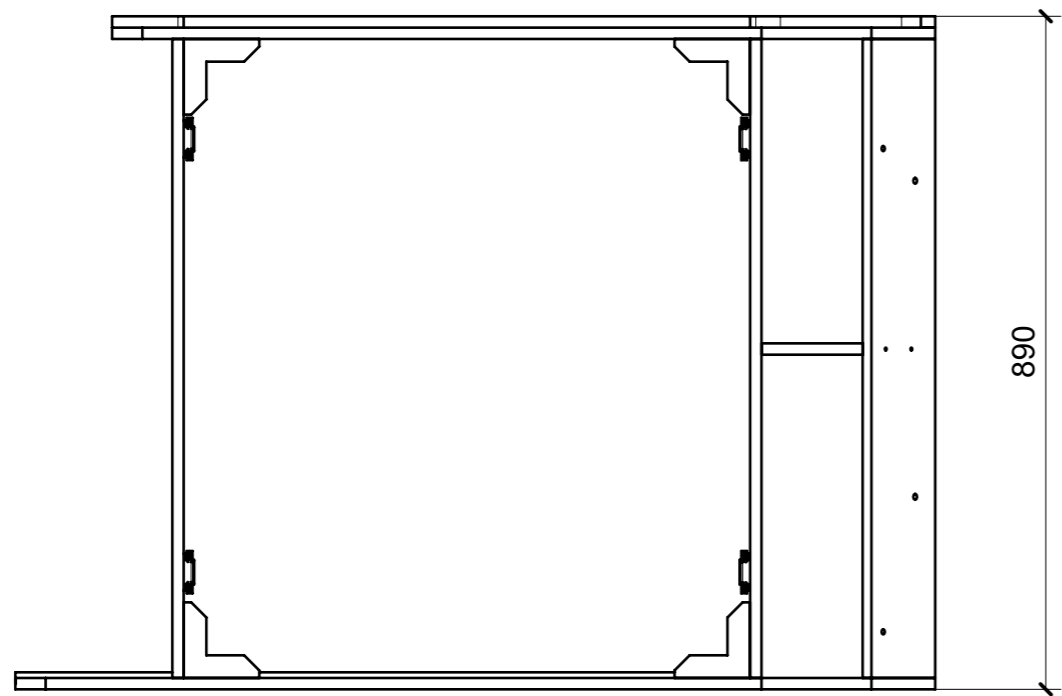

01

FERRAMENTA	QTY
CHIUSURA A SPINTA_TECHNOPARTNER_SOU C3-203	4

LOCALE	CODICE	DESCRIZIONE COMPONENTE	FINITURA	GR.
TIMONERIA	MD320_TD01	STRUTTURA DX LATERALE QUADRI	OKUME' GREZZO	2

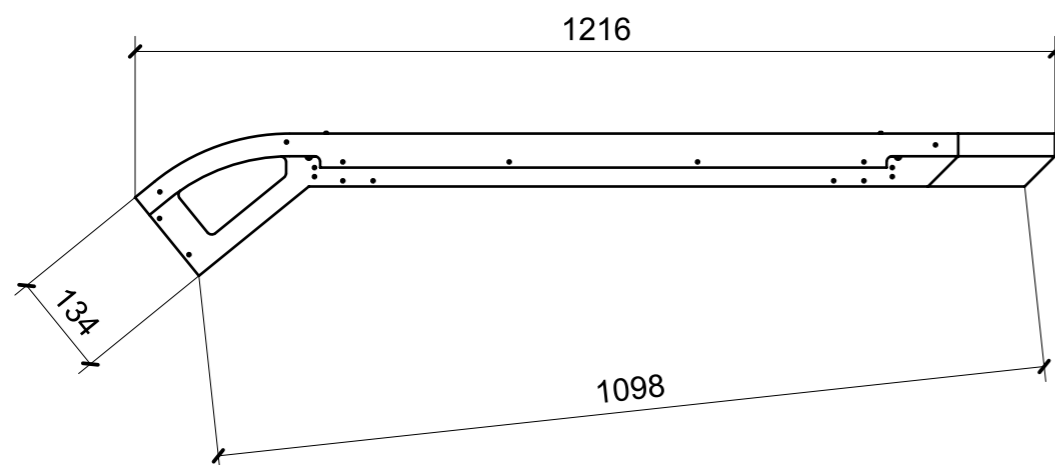
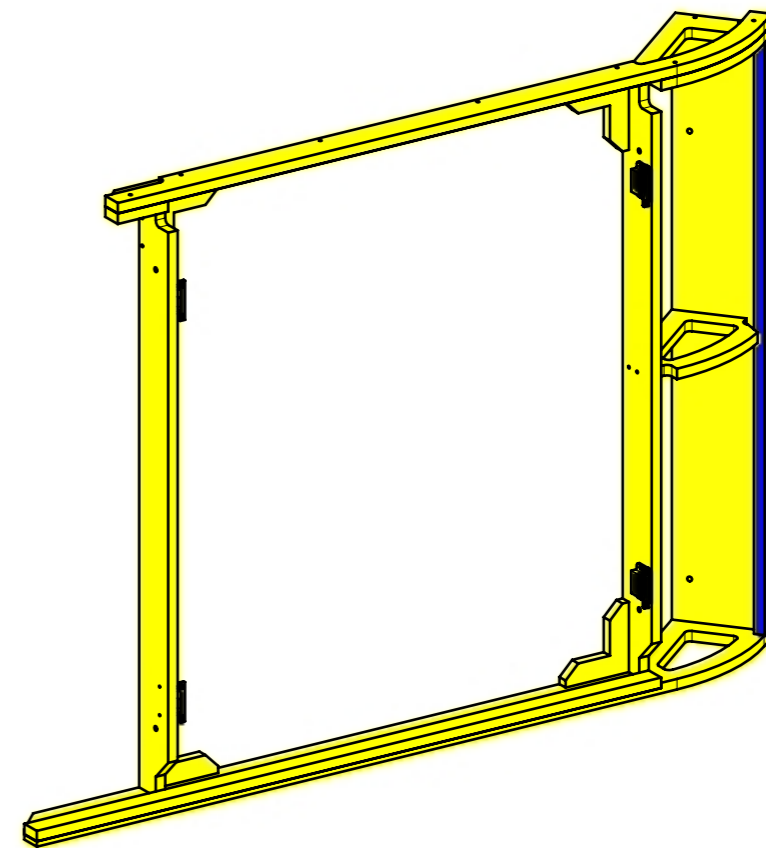
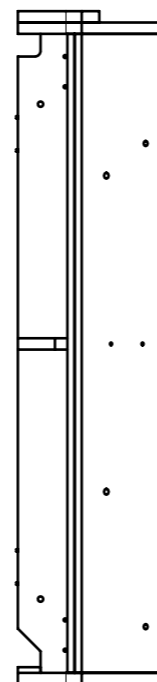
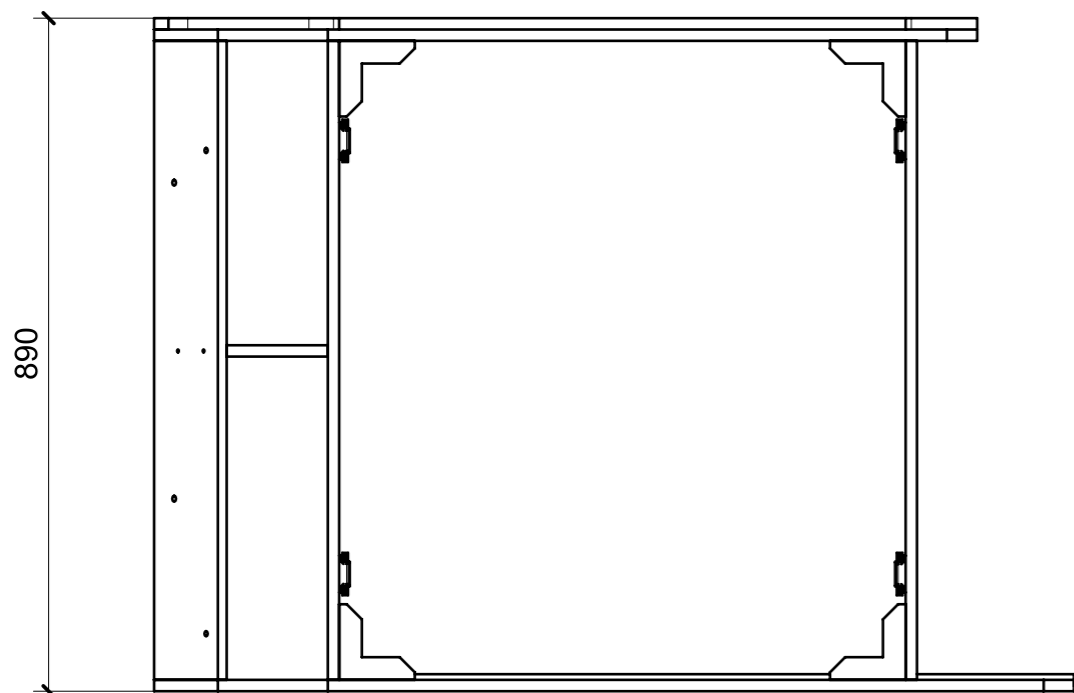

01

FERRAMENTA	QTY
CHIUSURA A SPINTA_TECHNOPARTNER_SOU C3-203	4

LOCALE	CODICE	DESCRIZIONE COMPONENTE	FINITURA	GR.
TIMONERIA	MD320_TE01	STRUTTURA FRONTALE SOTTO QUADRI ELETTRICI	OKUME' GREZZO	2

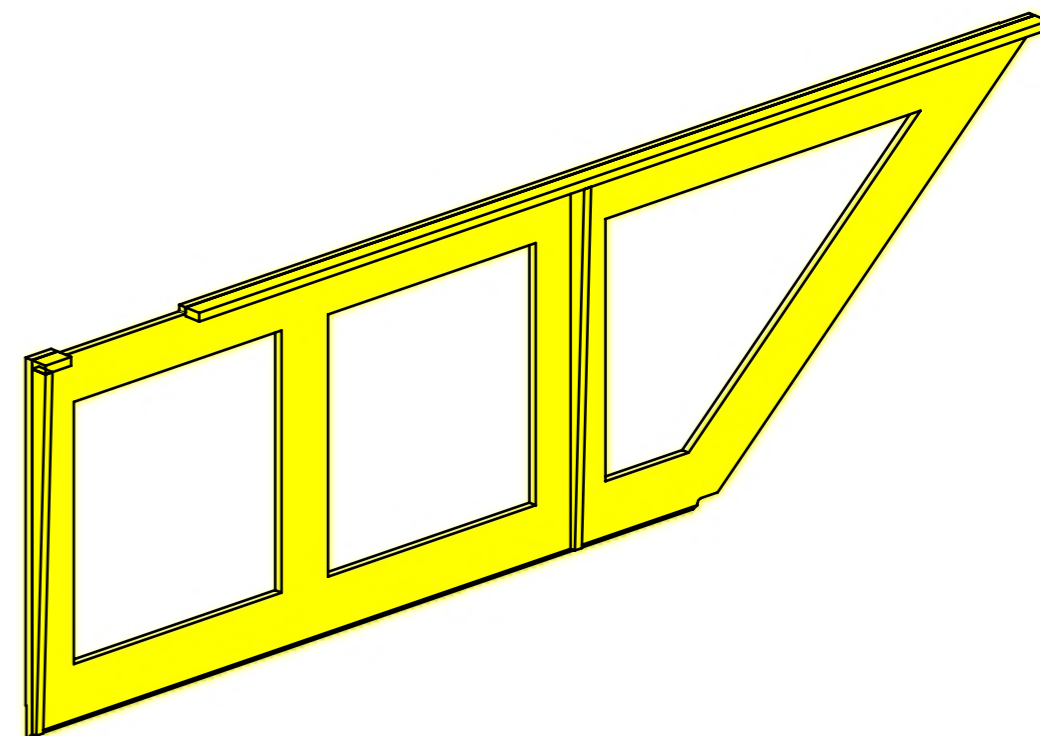
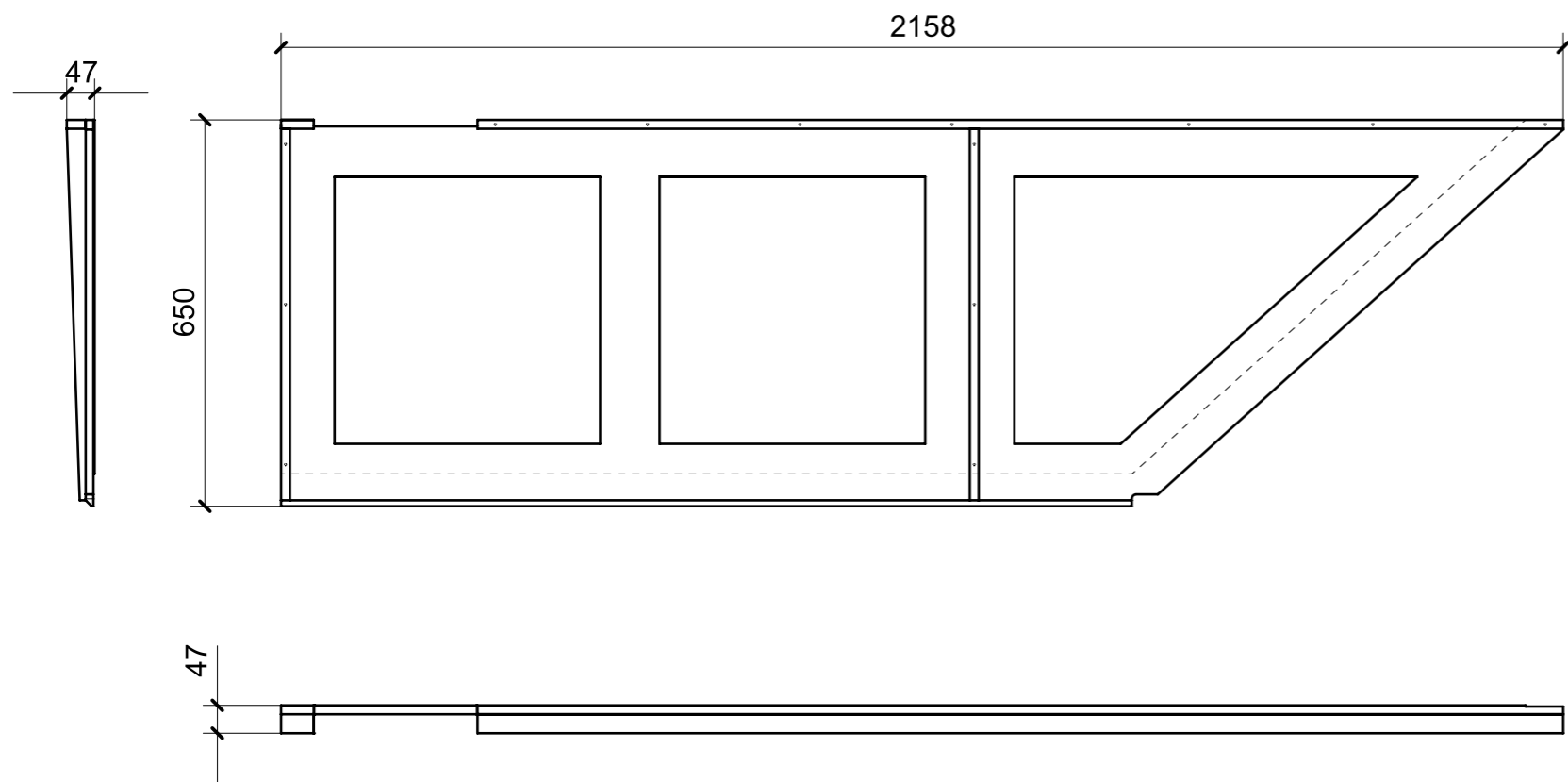

01

LOCALE	CODICE	DESCRIZIONE COMPONENTE	FINITURA	GR.
TIMONERIA	MD320_TG01	STRUTTURA CON RIV. RETRO POLTRONE	OKUME' GREZZO	PTP

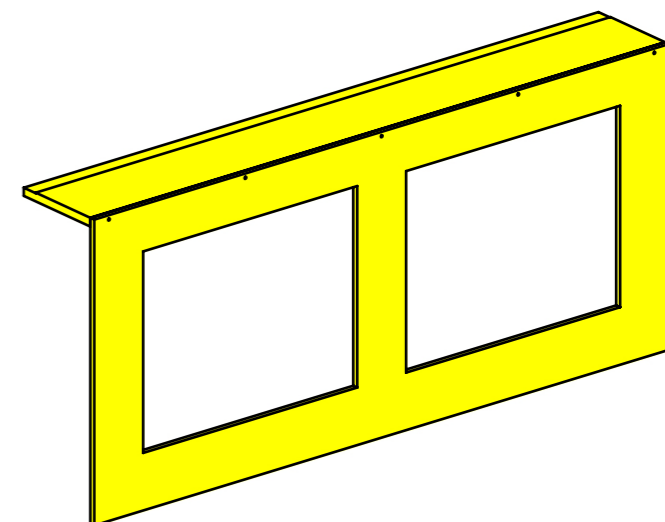
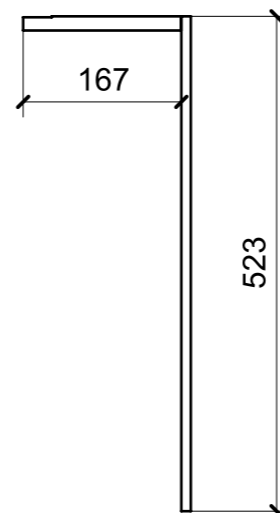
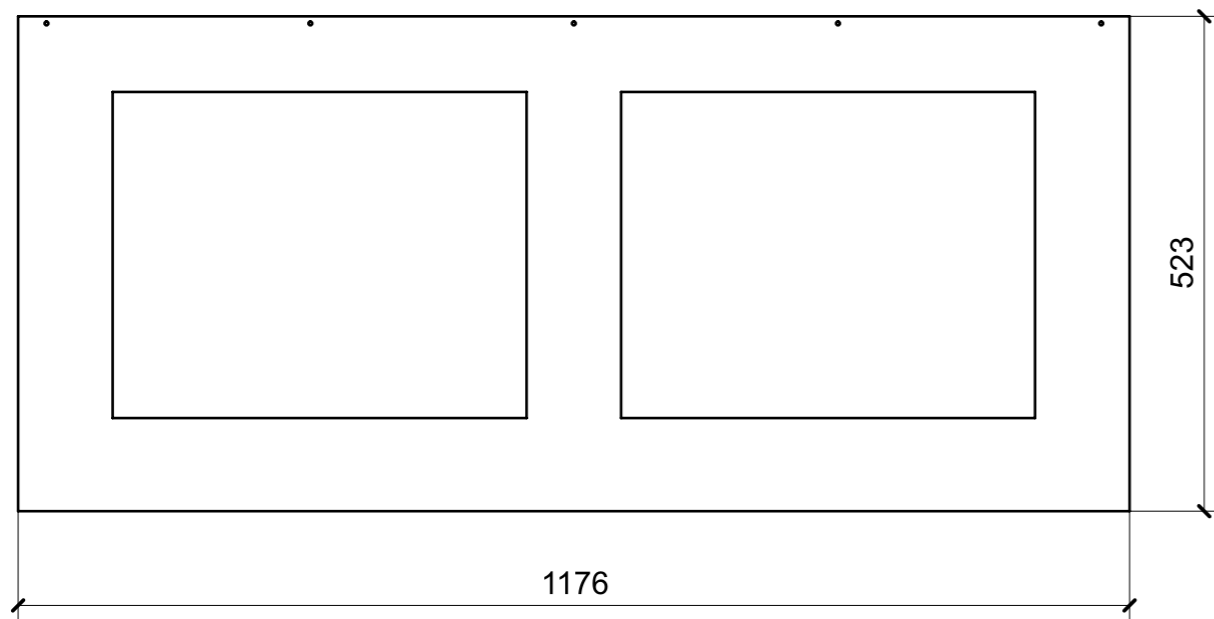

01

LOCALE	CODICE	DESCRIZIONE COMPONENTE	FINITURA	GR.
TIMONERIA	MD320_TH01	STRUTTURA A L PARETE CENTRONAVE	OKUME' GREZZO	PTP

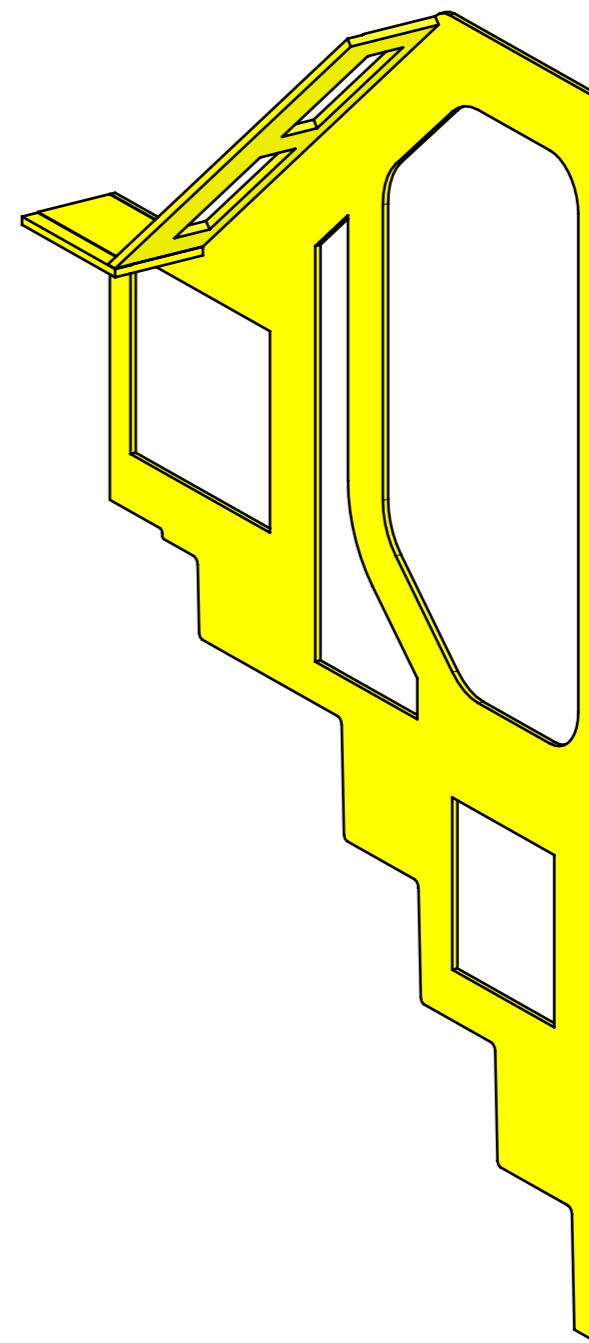
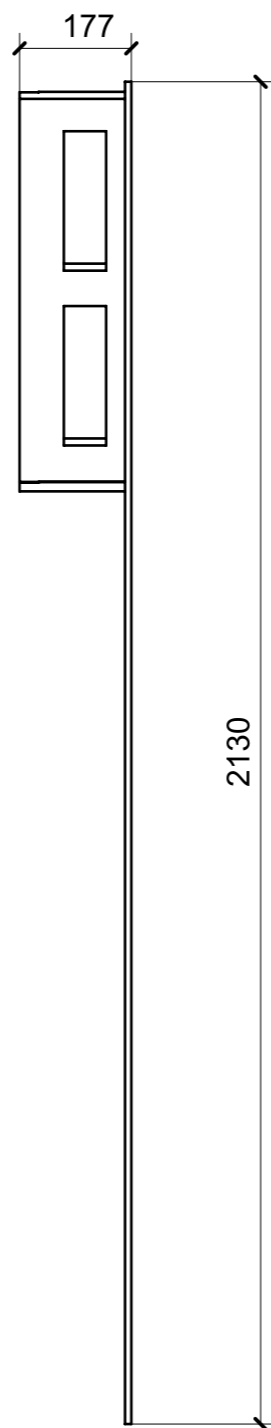
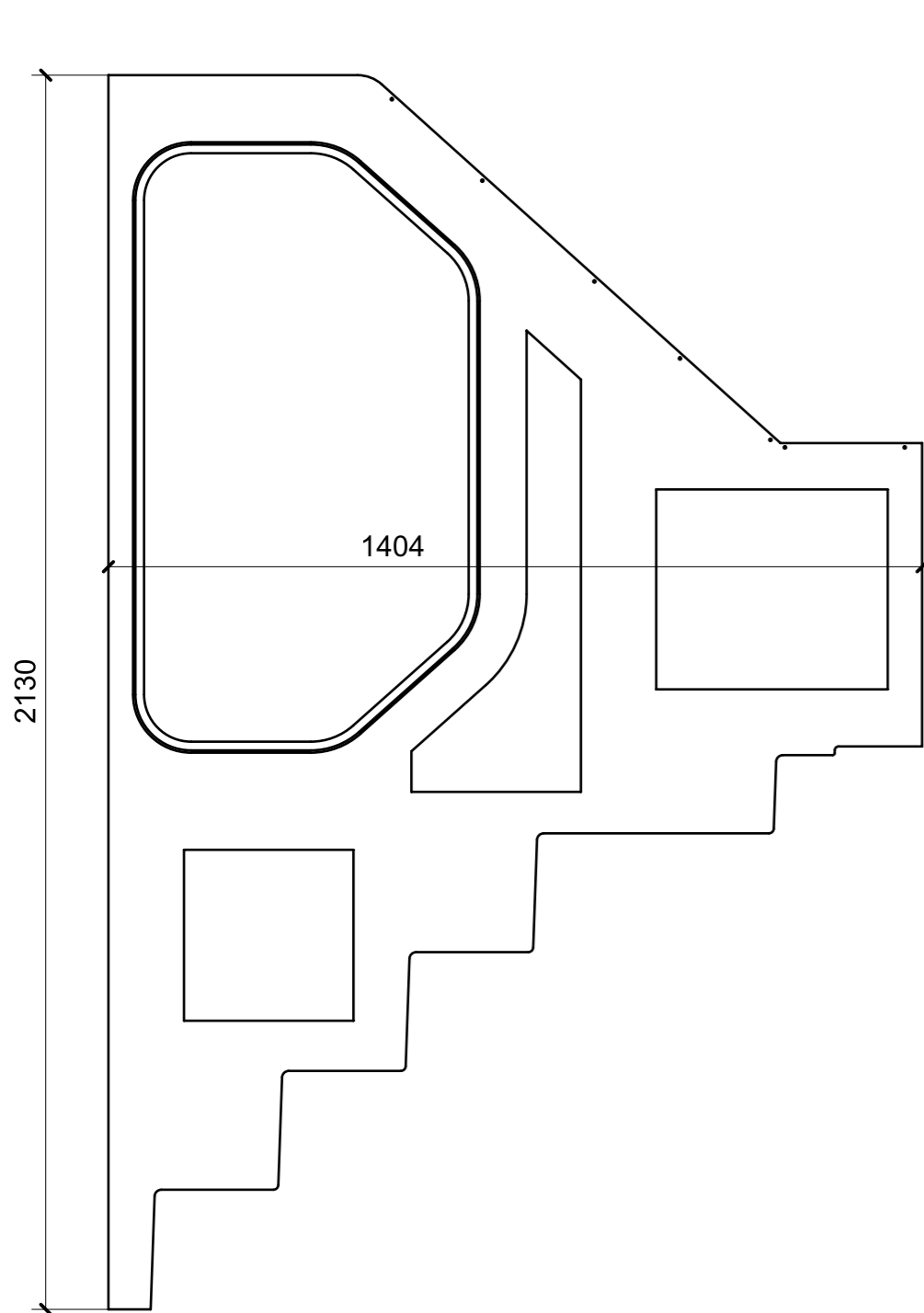

01

LOCALE	CODICE	DESCRIZIONE COMPONENTE	FINITURA	GR.
TIMONERIA	MD320_TI01	STRUT. INGROSSO PARETE CENTRONAVE	OKUME' GREZZO	PTP

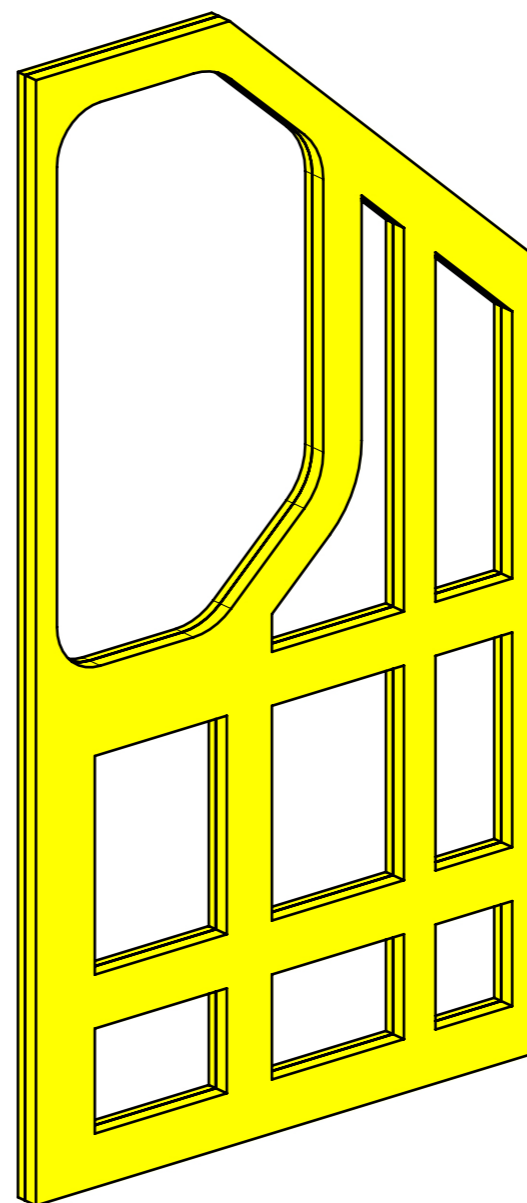
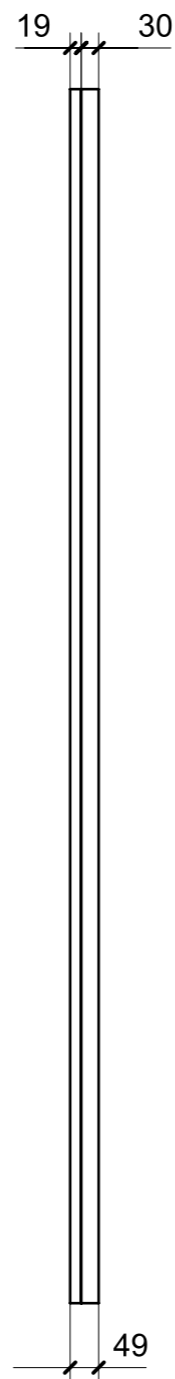
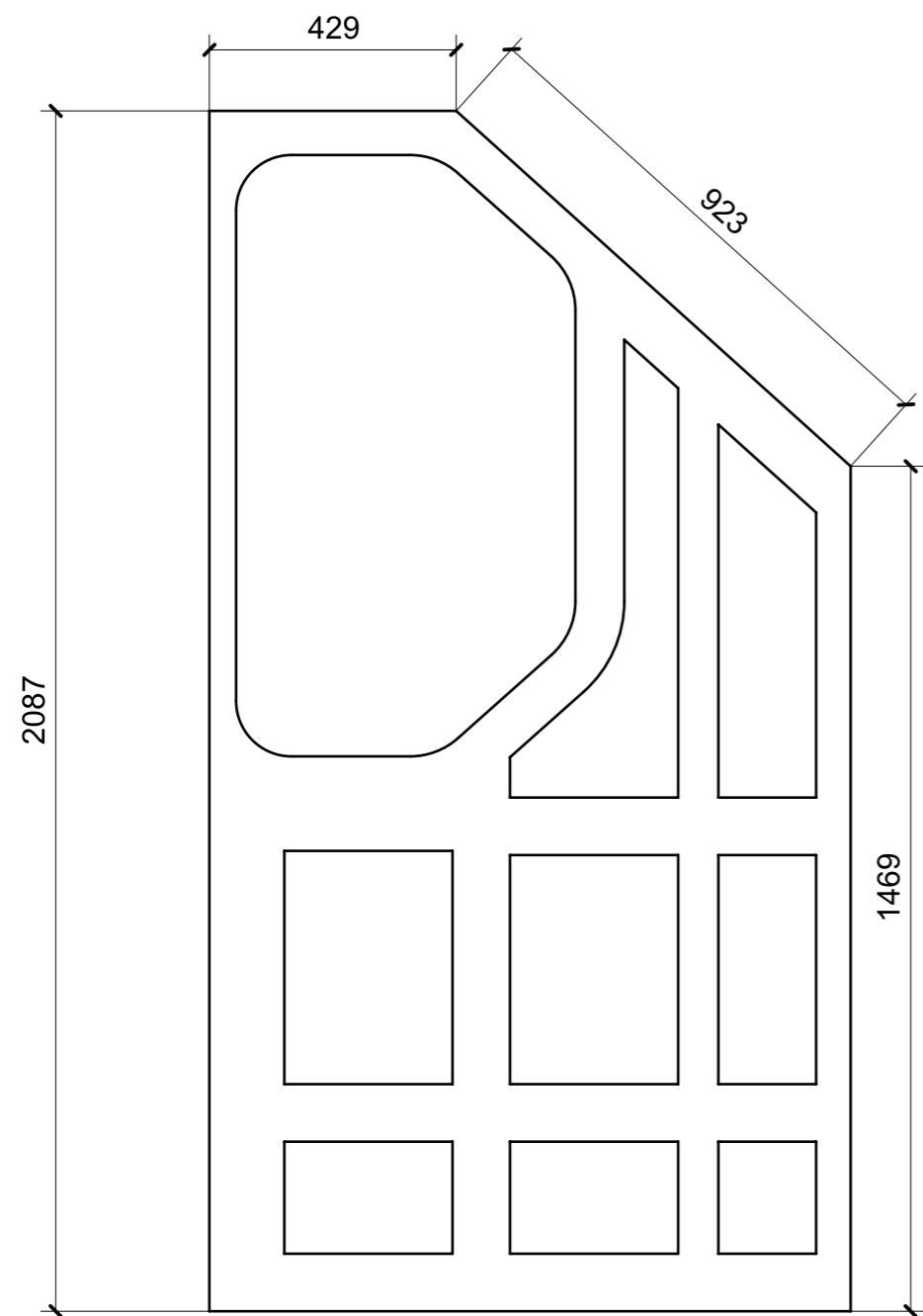

01

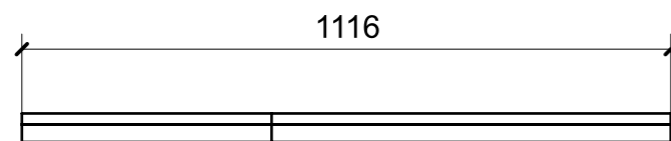

LOCALE	CODICE	DESCRIZIONE COMPONENTE	FINITURA	GR.
TIMONERIA	MD320_TM01	STRUTTURA CIELINO DX	OKOUME' GREZZO\ CARTA MELAMINICA NERA	2

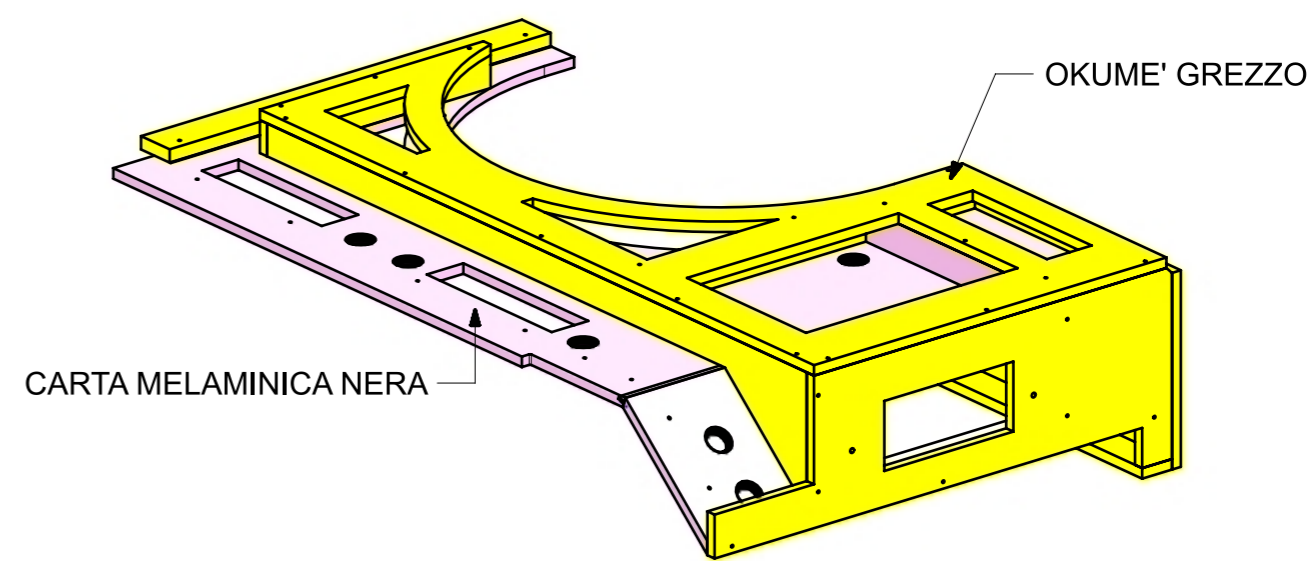
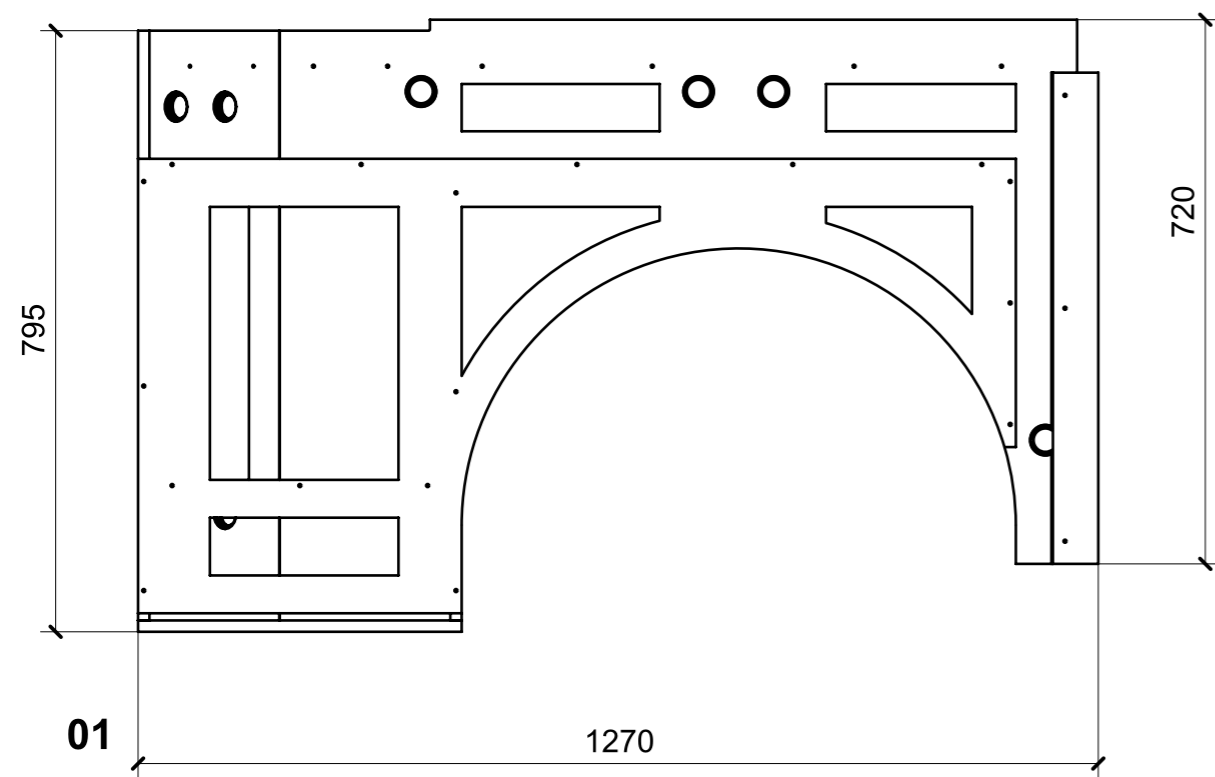
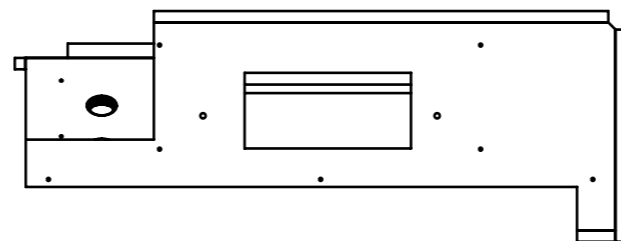
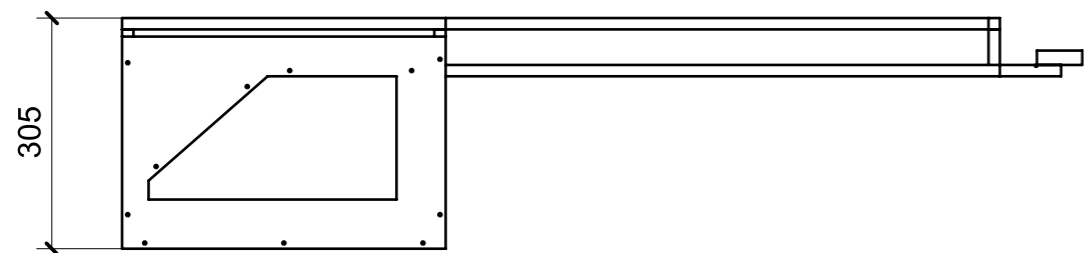

FERRAMENTA	QTY
FITLOCK F_MASCHERPA_6020101102	11

LOCALE	CODICE	DESCRIZIONE COMPONENTE	FINITURA	GR.
TIMONERIA	MD320_TO01	STRUTTURA CIELINO SX	CARTA MELAMINICA NERA	2

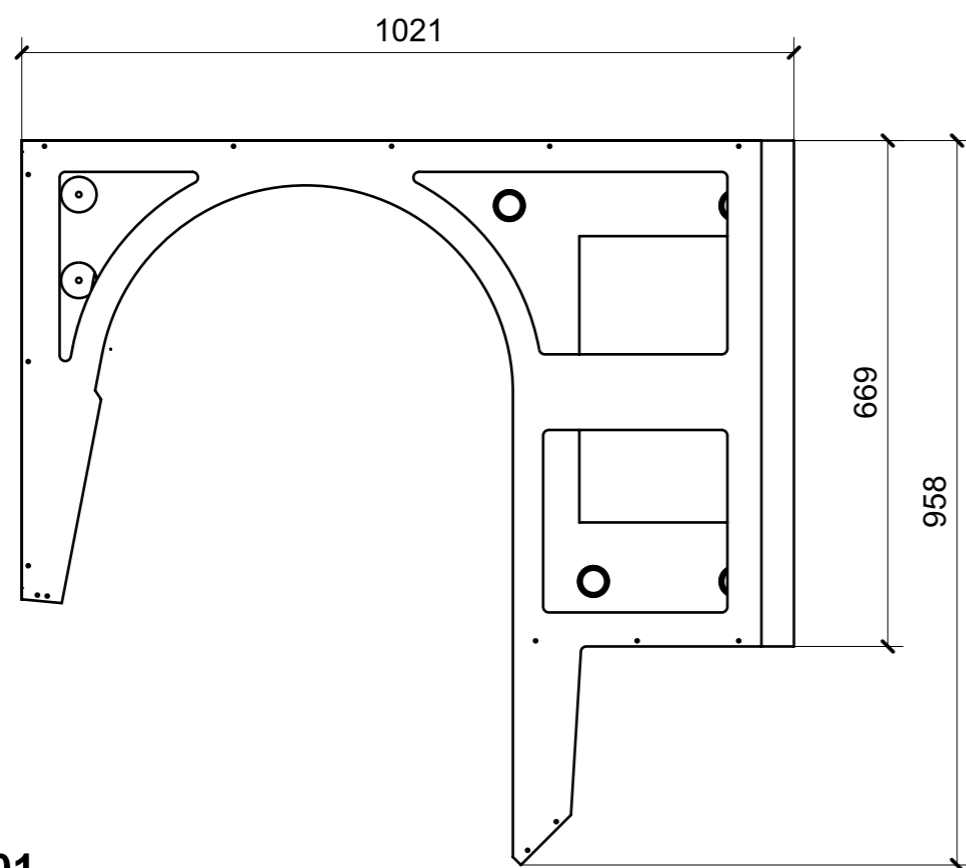
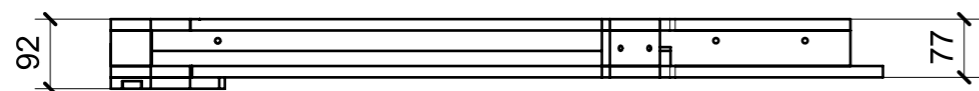

01

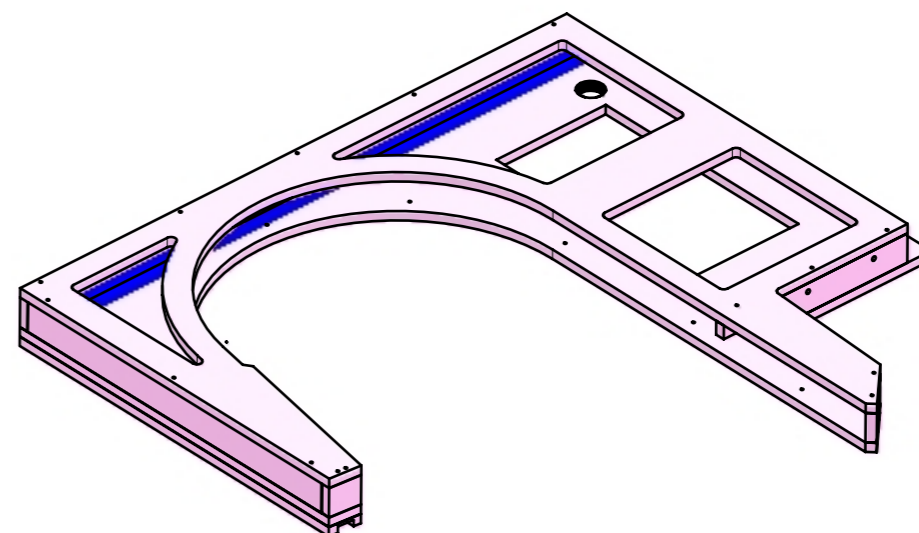

FERRAMENTA	QTY
FITLOCK F_MASCHERPA_6020101102	4

LOCALE	CODICE	DESCRIZIONE COMPONENTE	FINITURA	GR.
TIMONERIA	MD320_TP01	CIELINO DISCESA MARINAIO	LACCATO NCS- S - 1002-Y -MANOPESCA	PTP

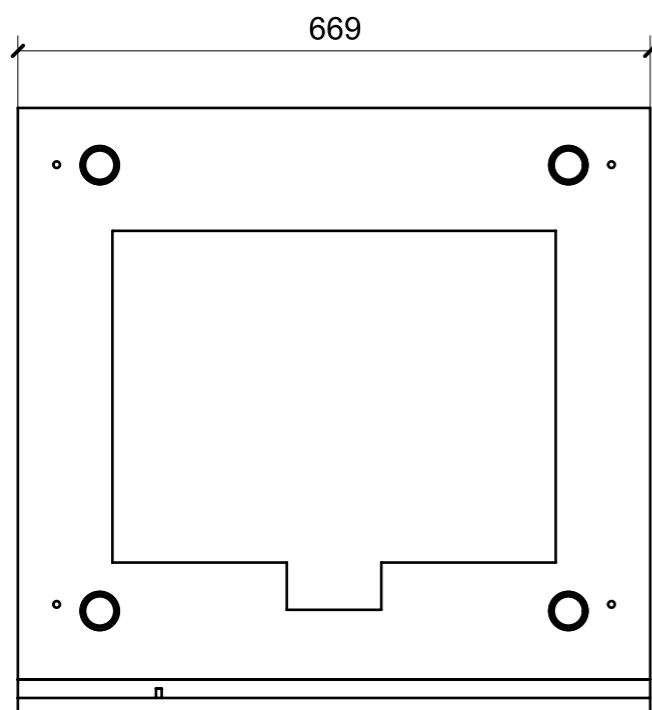

01

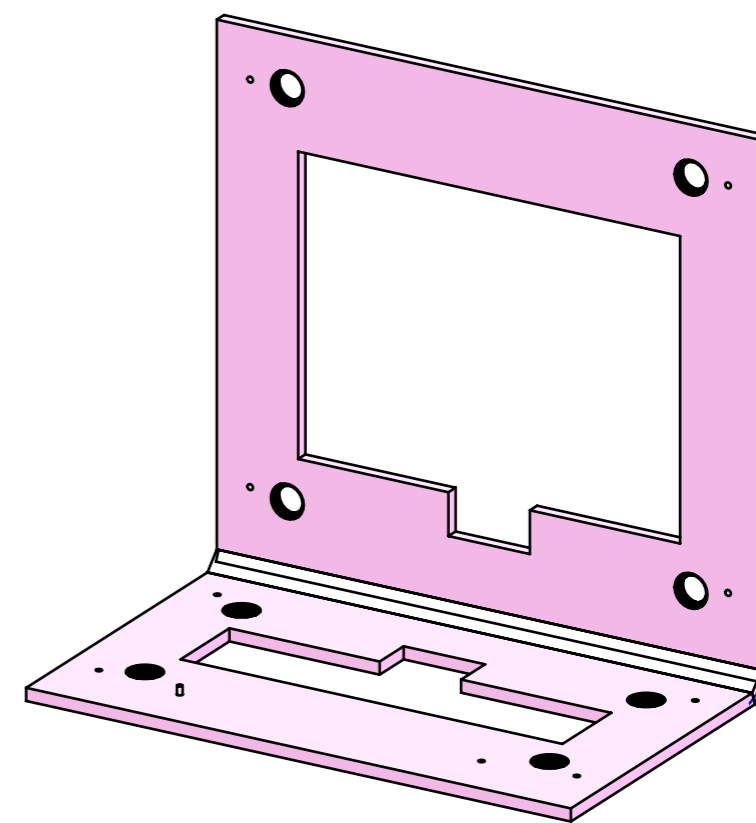
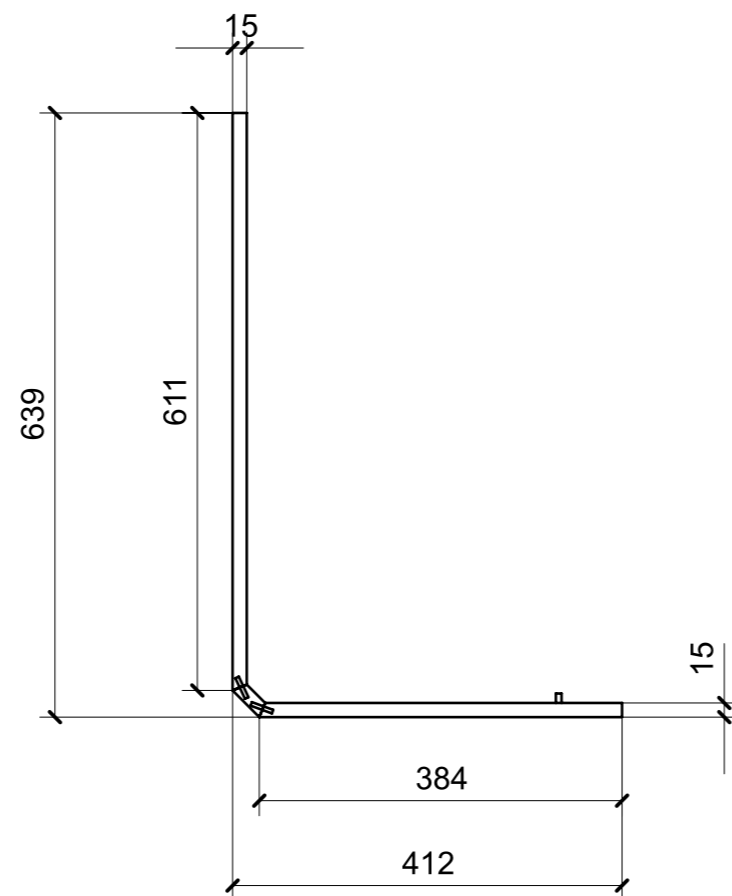

FERRAMENTA	QTY
FITLOCK F_MASCHERPA_6020101102	8

LOCALE	CODICE	DESCRIZIONE COMPONENTE	FINITURA	GR.
TIMONERIA	MD320_TQ01	MOBILETTO ALLARMI TIMONERIA	LAMINATO NERO OPACO	PTP

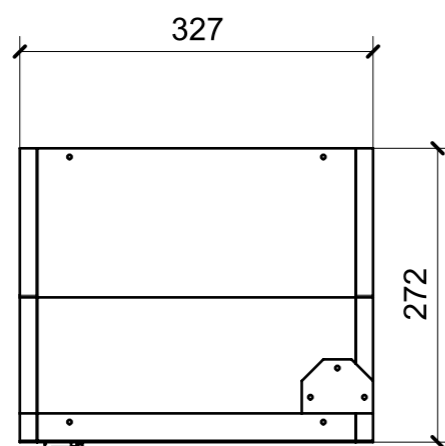
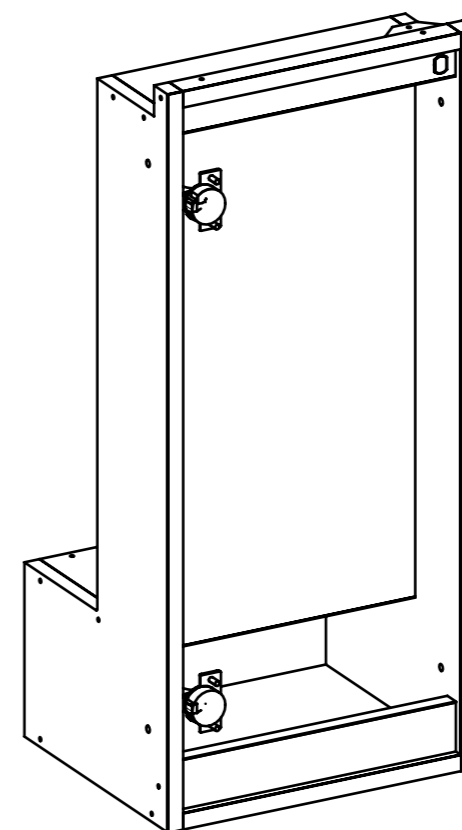
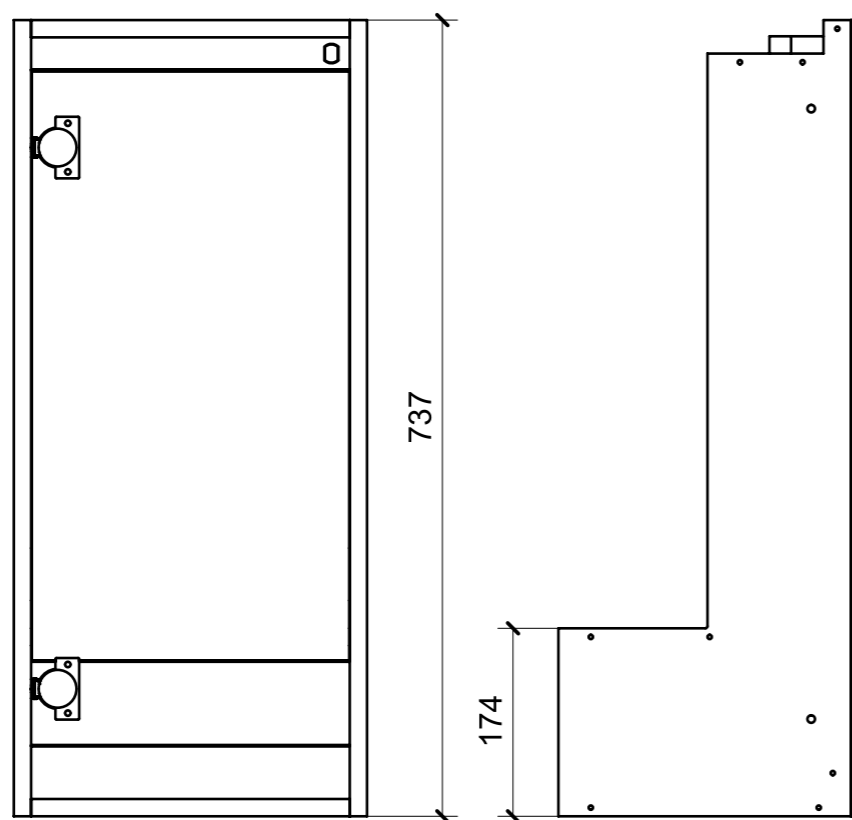

01

FERRAMENTA	QTY
CRICCHETTO A PRESSIONE _HAFELE_356_04_353_1	1
BASE_0-NERA_HAFELE_342.22.065-BLUM_175H3100.STP	2
CERNIERA 95° _COLLO	2
PIENO-NERA_HAFELE_342.46.606-BLUM_71B9750.STP	4
VITE 4MAX8 ANKOR BORGHI X BASE 0	4
CHIUSURA A SPINTA _TECHNOPARTNER_SOU C3-203	3
BUSSOLA 5MA ANKOR BORGHI X BASE 0	4

LOCALE	CODICE	DESCRIZIONE COMPONENTE	FINITURA	GR.
TIMONERIA	MD320_TS01	PARETE OBLO'	OKUME' GREZZO	2

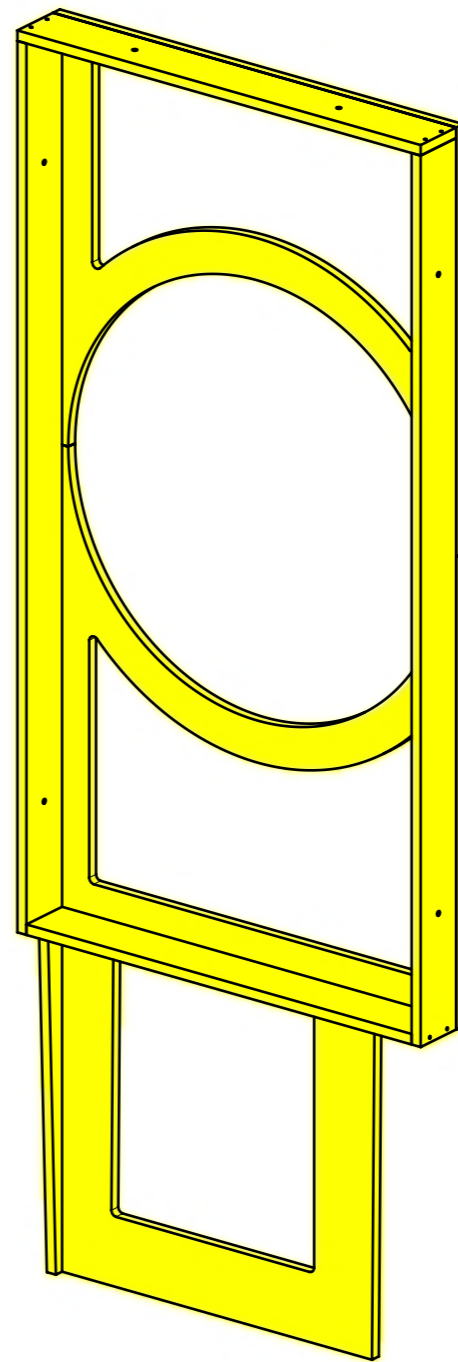
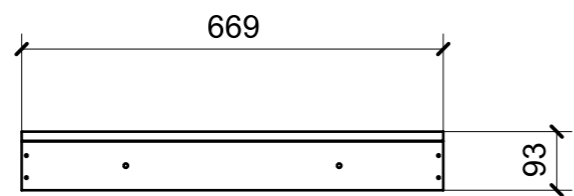
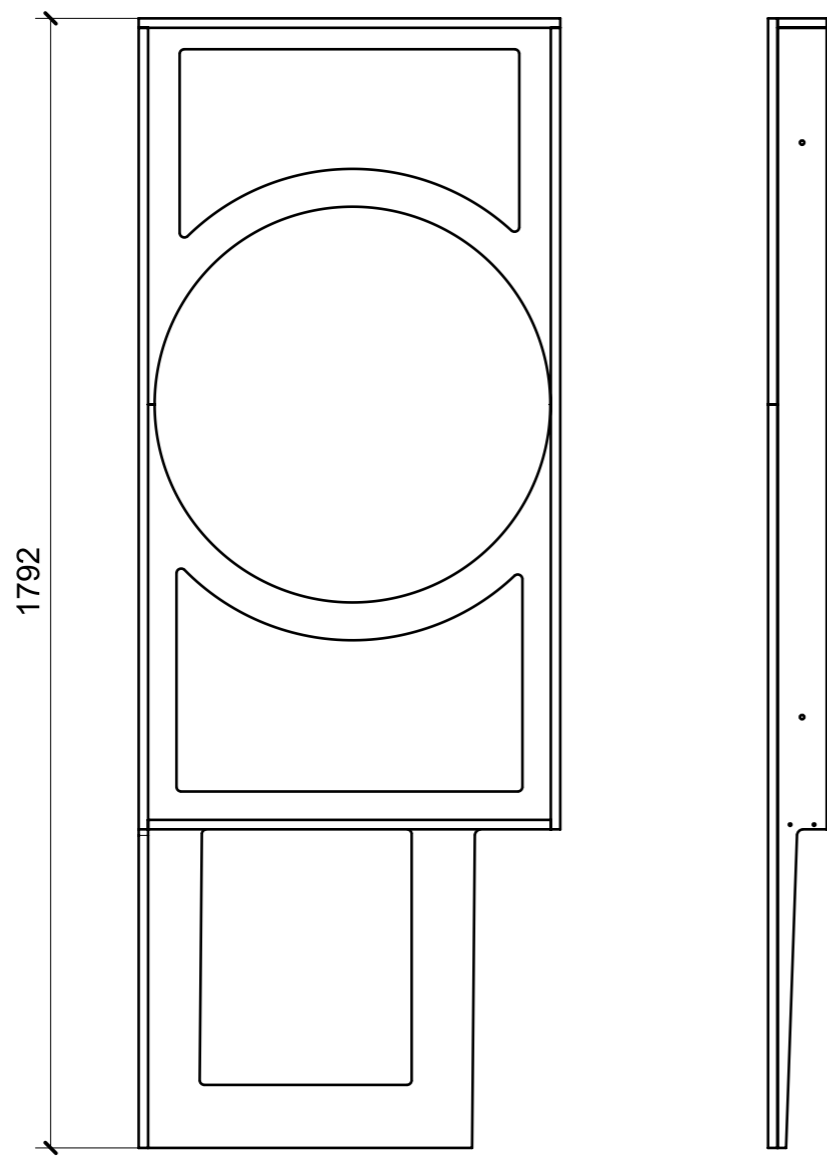

01

LOCALE	CODICE	DESCRIZIONE COMPONENTE	FINITURA	GR.
TIMONERIA	MD320_TT01	PLENUM SOPRA OBLO' DISCESA SCALE	GREZZO VERNICIATO ANTI ROMBO	PTP

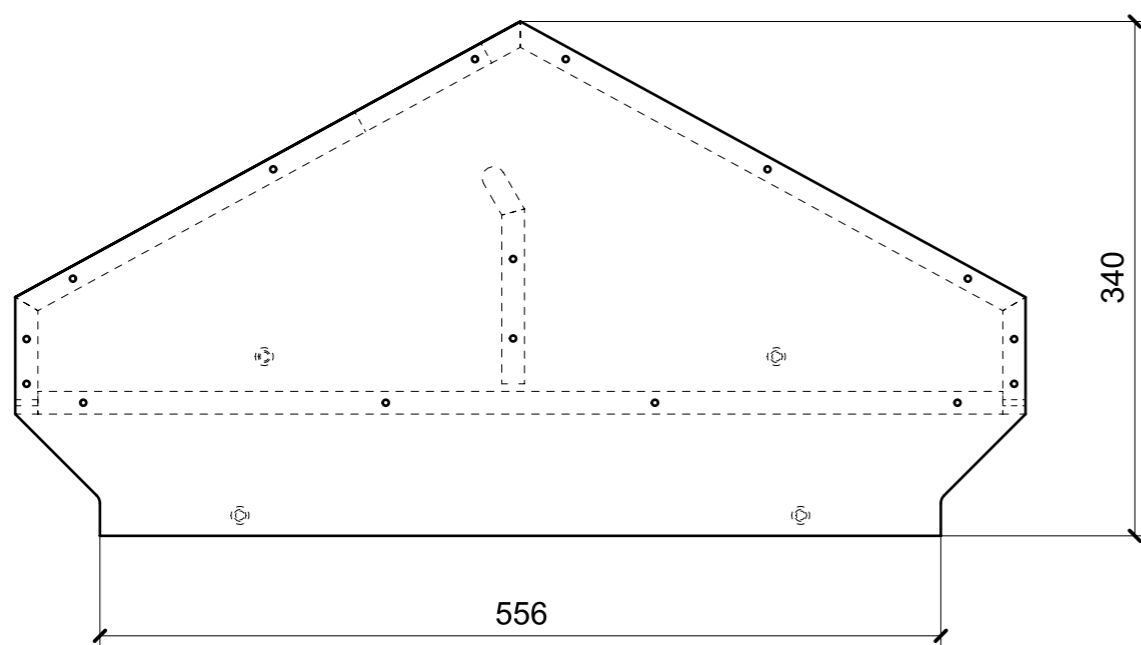
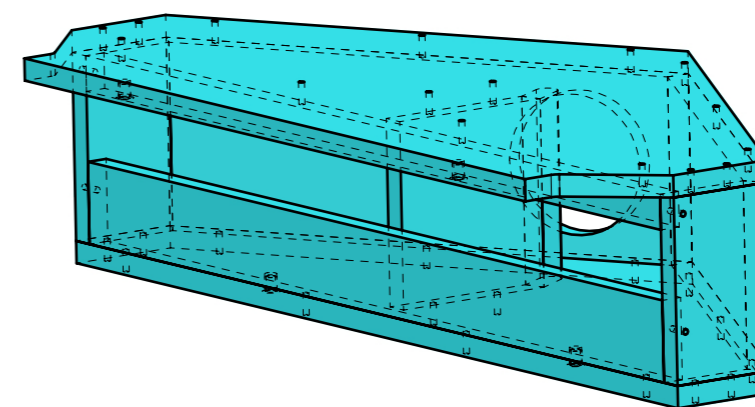
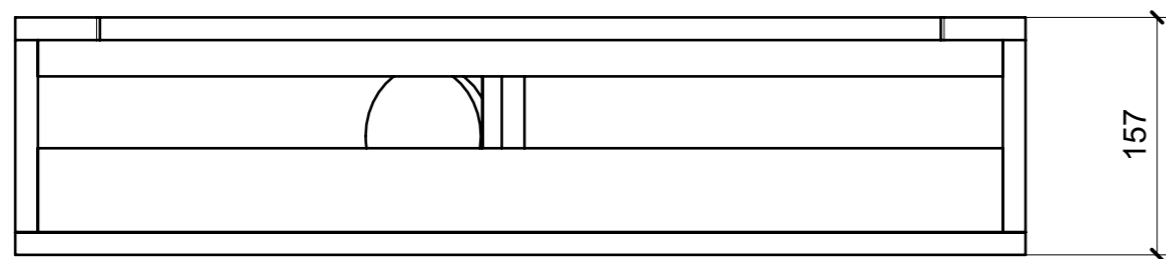

01

FERRAMENTA	QTY
BUSSOLA 6MA X 10 FORO DIAM.8	4

LOCALE	CODICE	DESCRIZIONE COMPONENTE	FINITURA	GR.
TIMONERIA	MD320_TU01	BLOCCO CENTRALE CRUSCOTTO TIMONERIA	OKUME' GREZZO	PTP

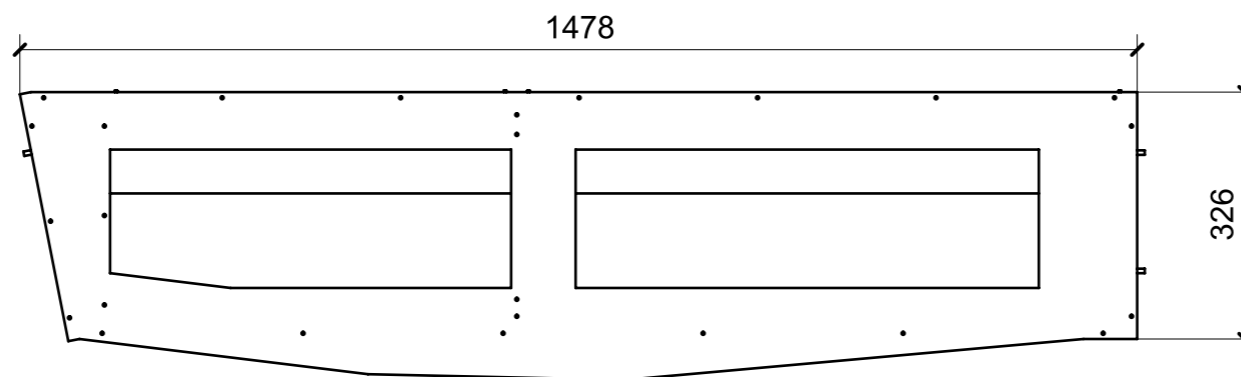
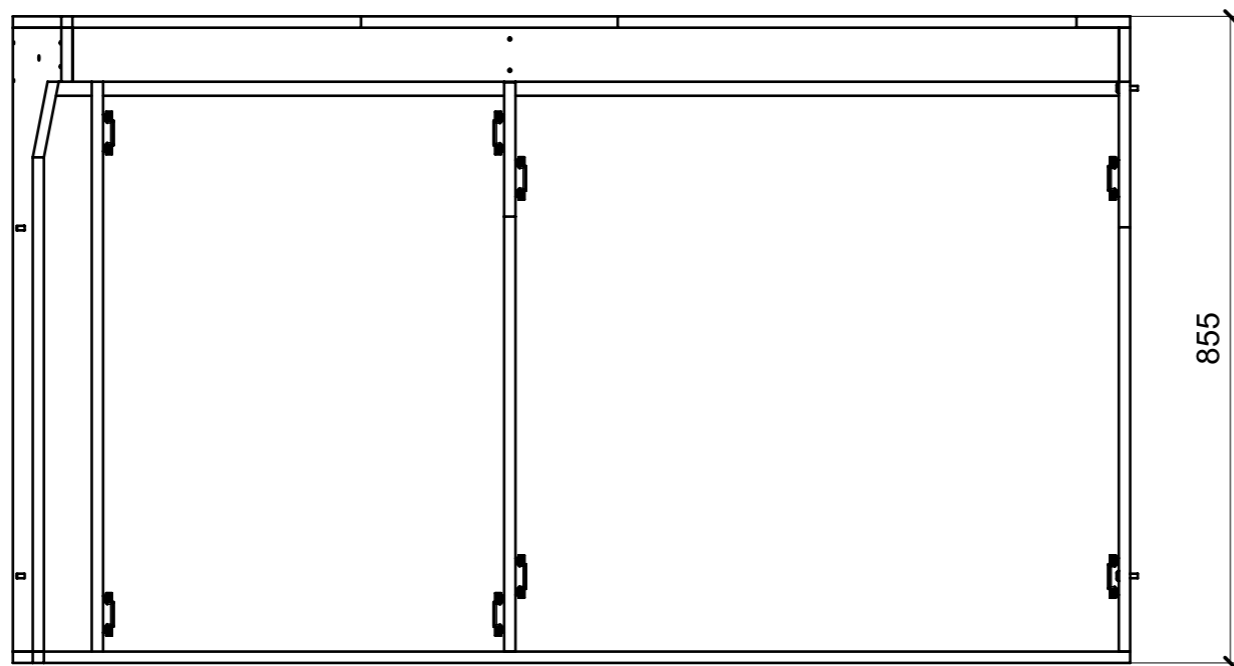
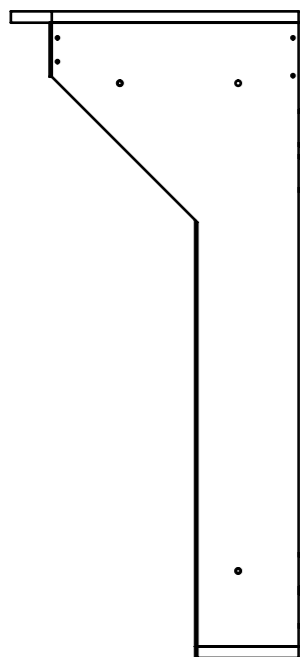

01

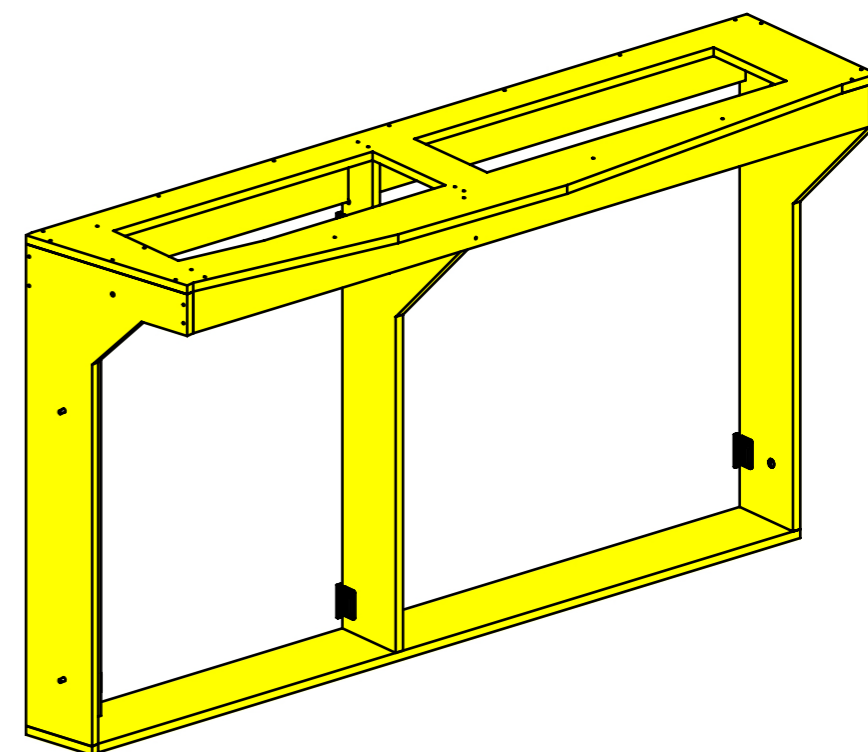

FERRAMENTA	QTY
CHIUSURA A SPINTA_TECHNOPARTNER_SOU C3-203	8

LOCALE	CODICE	DESCRIZIONE COMPONENTE	FINITURA	GR.
TIMONERIA	MD320_TX01	RIV. GRADINI DISCESA MARINAIO	OKUME' GREZZO	2

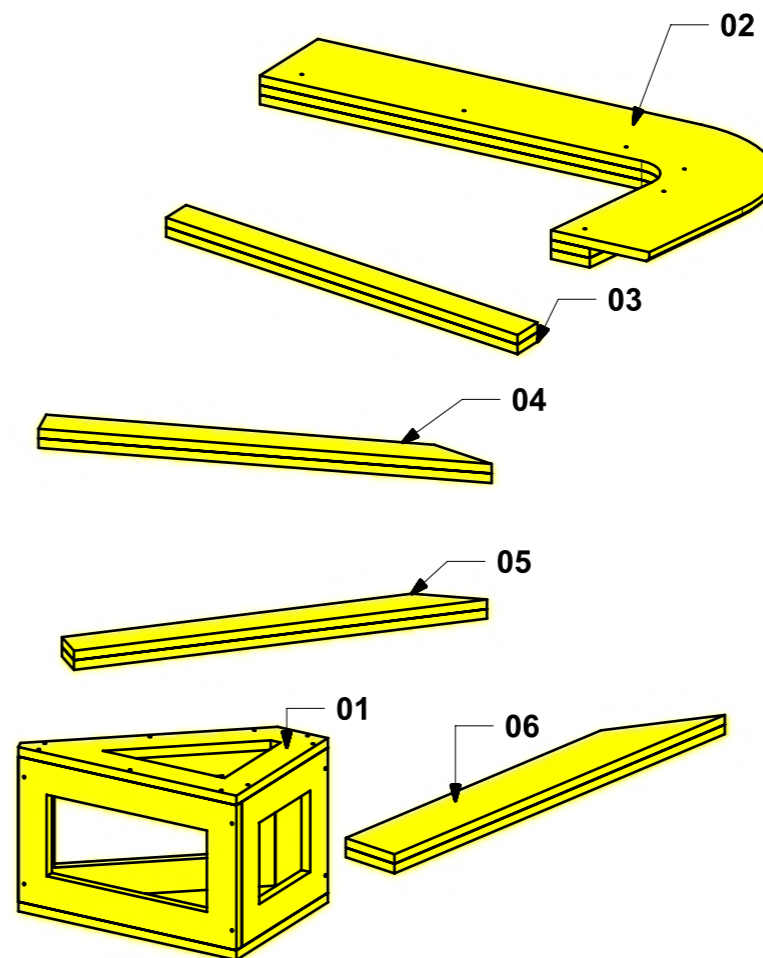
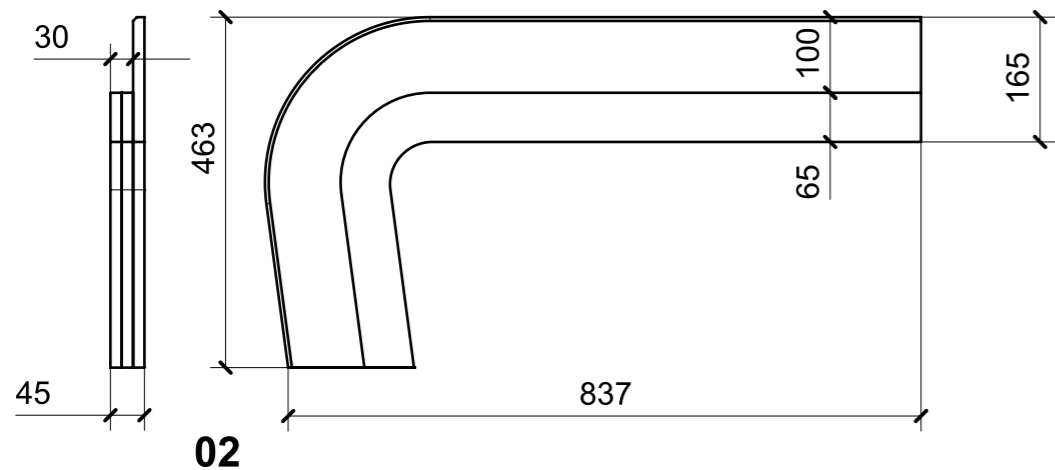
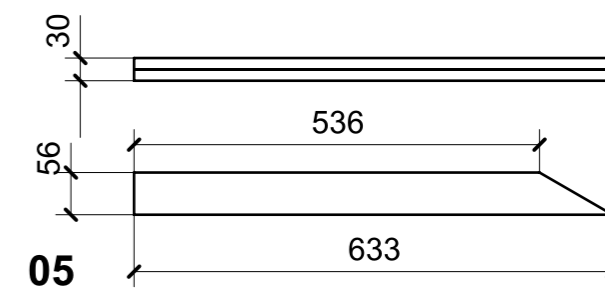
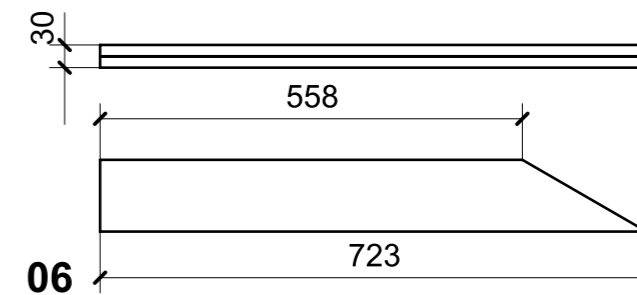
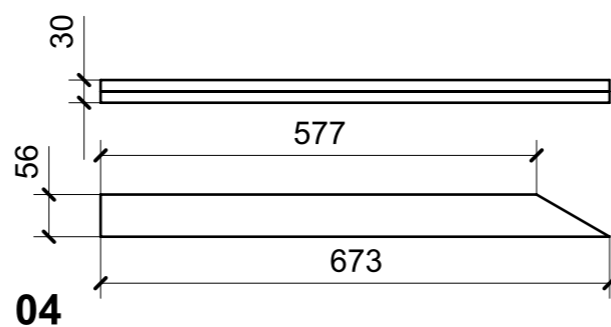
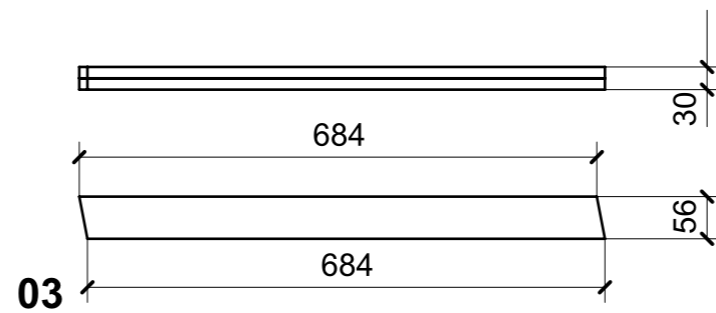
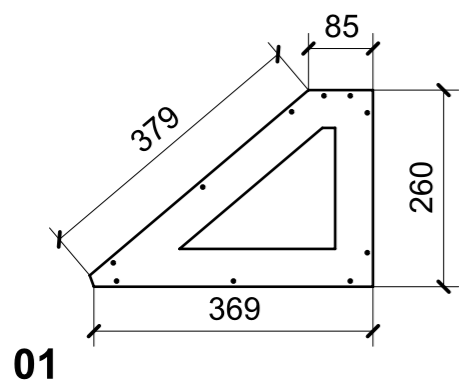
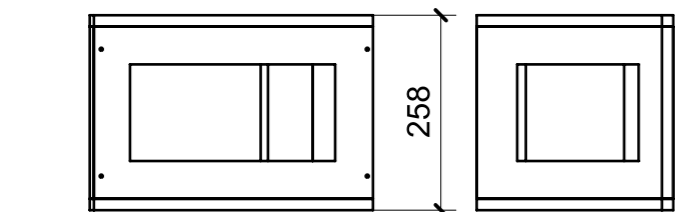

LOCALE	CODICE	DESCRIZIONE COMPONENTE	FINITURA	GR.
TIMONERIA	MD320_TY01	RIV. GRADINI DISCESA ARMATORE	OKUME' GREZZO	2

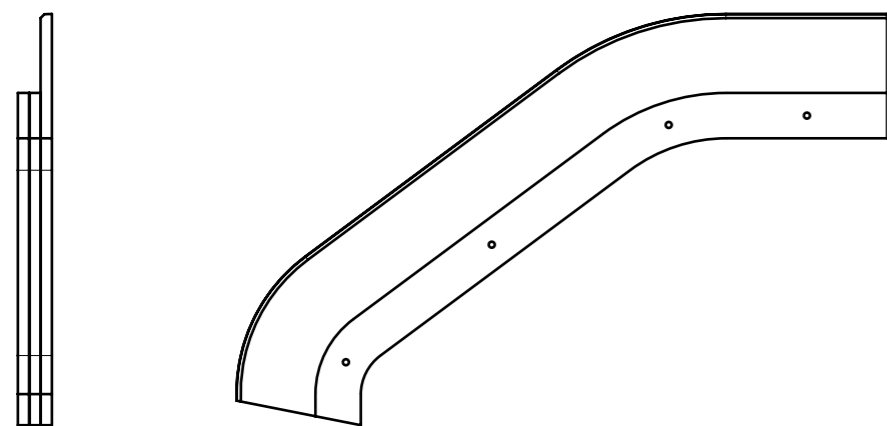

01

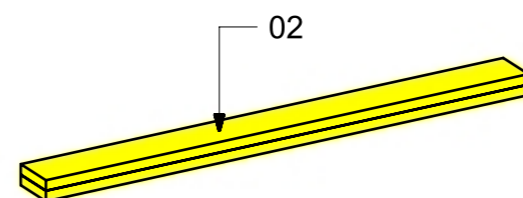
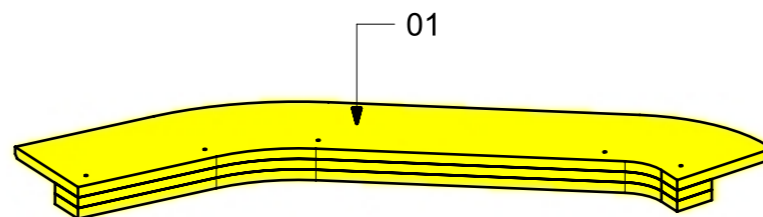

02

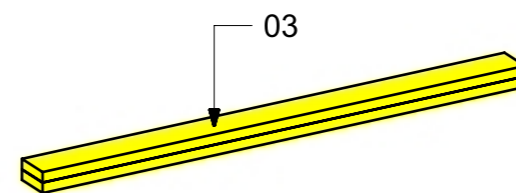
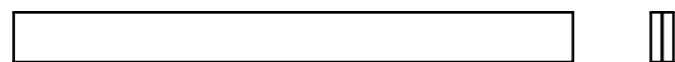

03

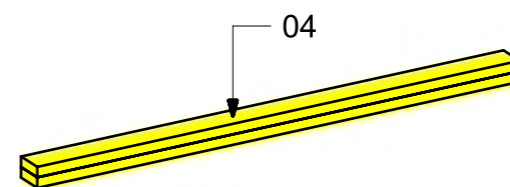
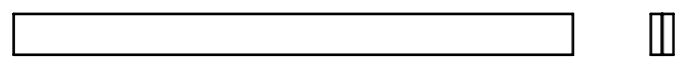

04

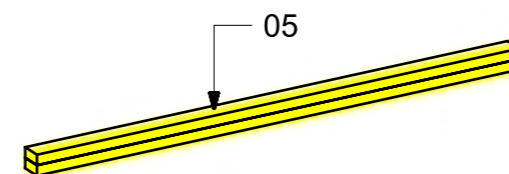
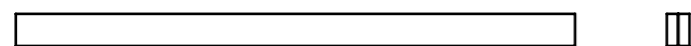

05

