

LOCALE	CODICE	DESCRIZIONE COMPONENTE	FINITURA	Q.TA
LOBBY	MD298_R01_CA01	MOBILE LAVATRICE	LASTRA CHIARA	1

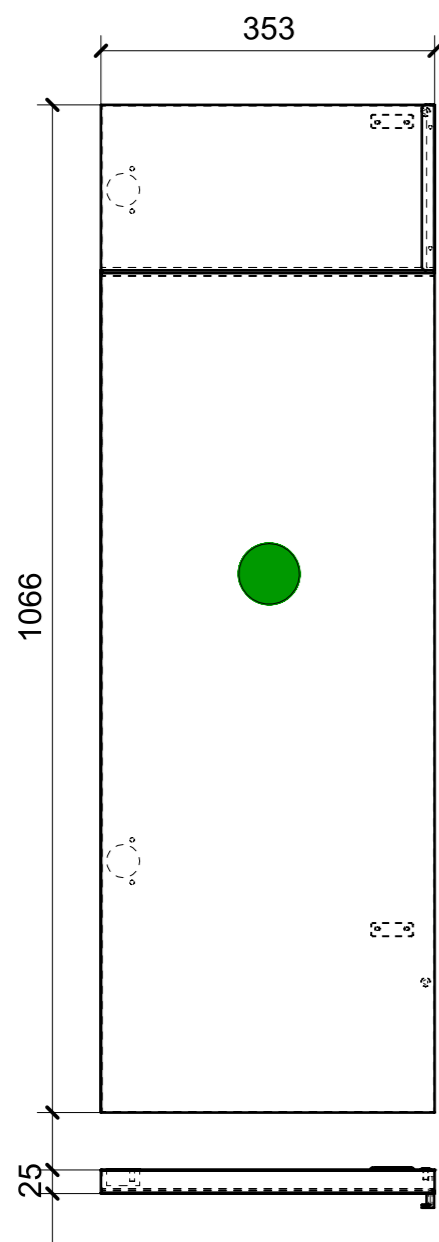

01

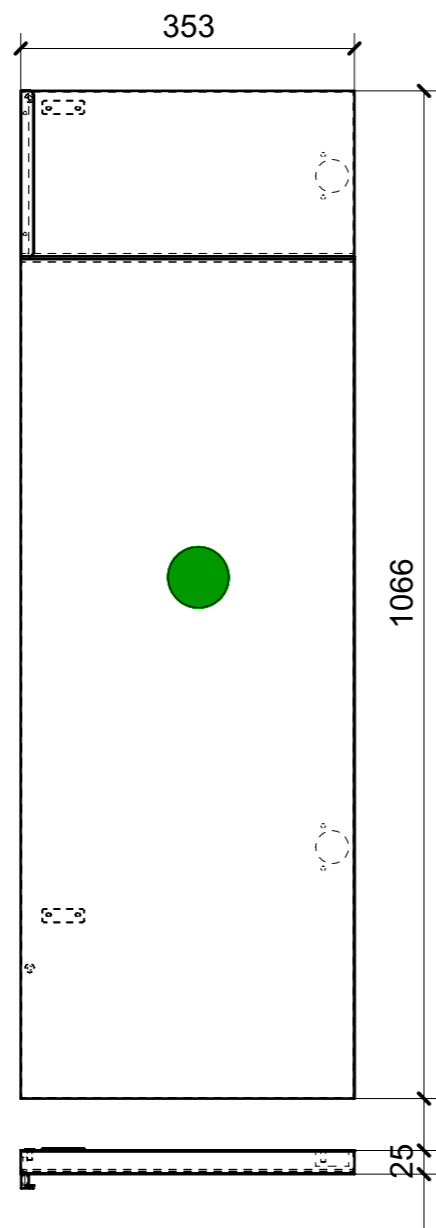

02

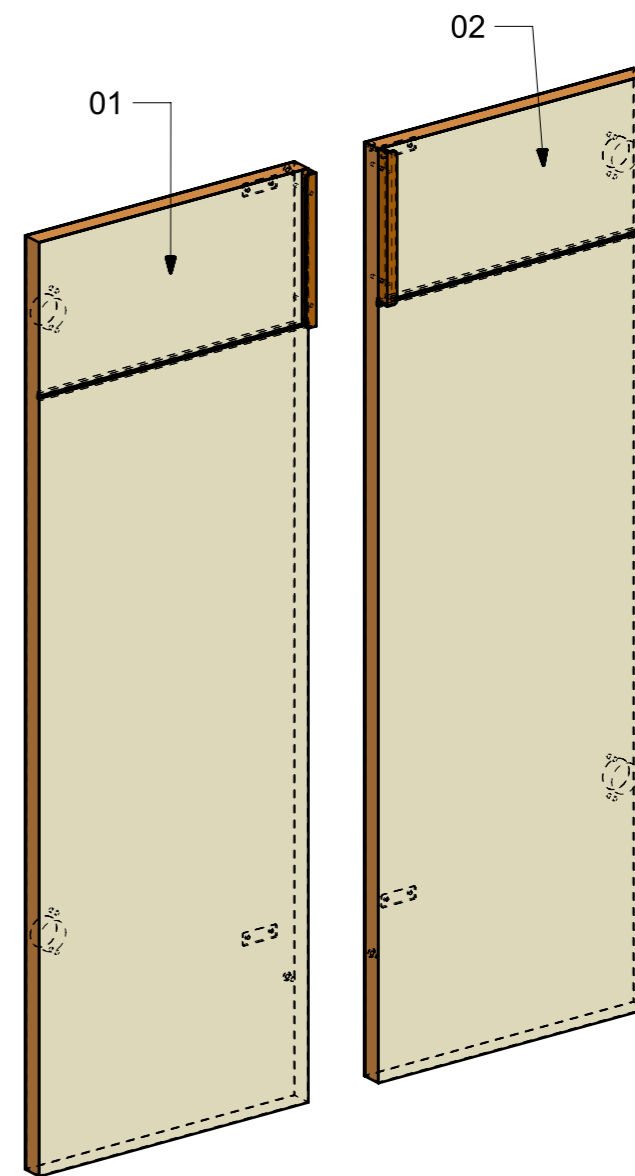

FERRAMENTA	QTY
GOMMINO PARACOLPO ANTA	4
MANIGLIA X MOBILE PAMAR_FBC BORGHINI_886Z-175 ALOP	2
PLACCHETTA COUNTER STEEL_TECHNOPARTNER_MC-JM49	4

VERNICIATURA LASTRA/LACCATI:

● = VERNICIARE 1 LATO + FILI RASATI O BORDATI

NESSUN SIMBOLO = VERNICIARE 2 LATI + FILI RASATI O BORDATI

LOCALE	CODICE	DESCRIZIONE COMPONENTE	FINITURA	Q.TA
LOBBY	MD298_R01_CB01	RIV. PARATIA DIVISORIA OSPITI	LASTRA CHIARA	1

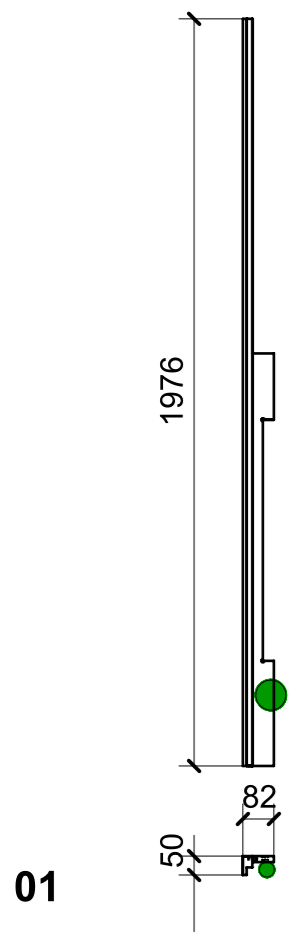

01

FERRAMENTA	QTY
BUSSOLA 5MA X 10 FORO DIAM.8	2

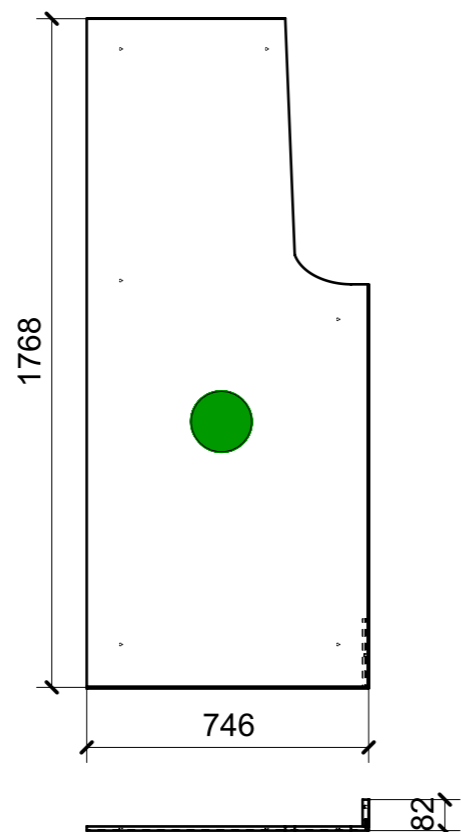

04

FERRAMENTA	QTY
BUSSOLA 5MA X 10 FORO DIAM.8	1

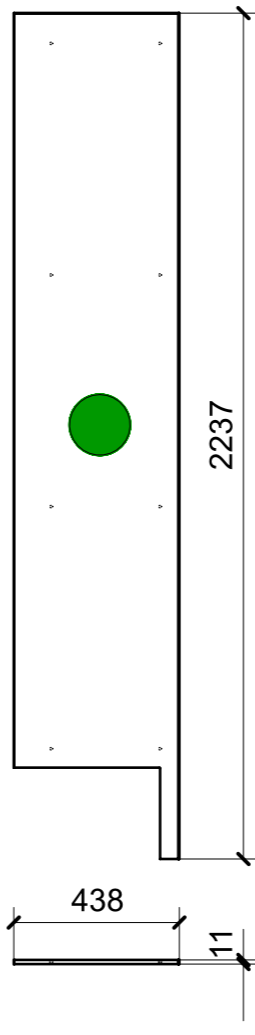

06

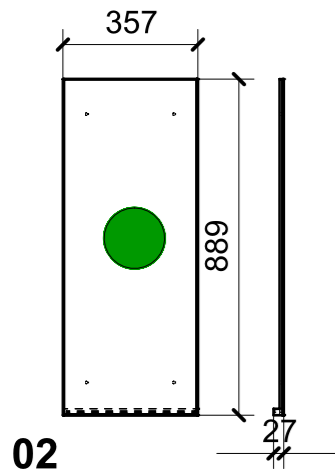
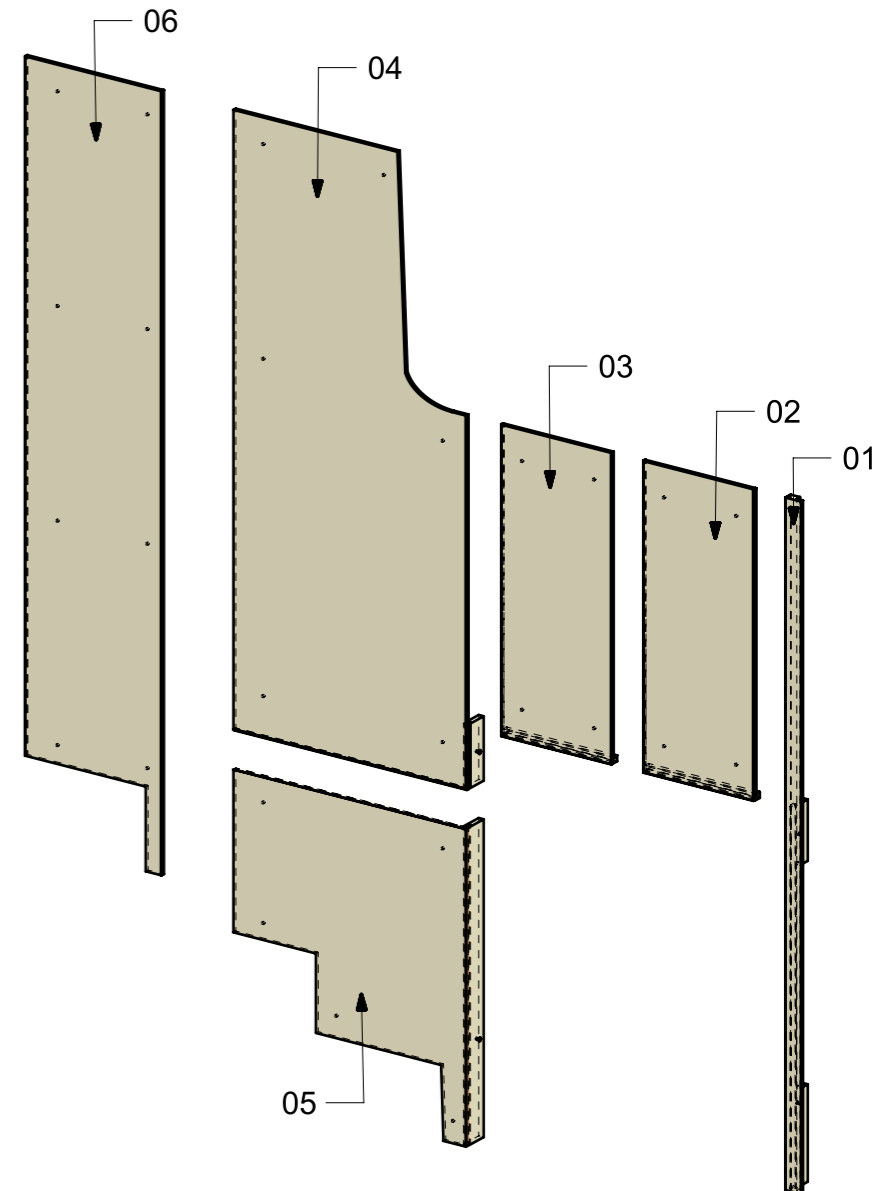

02

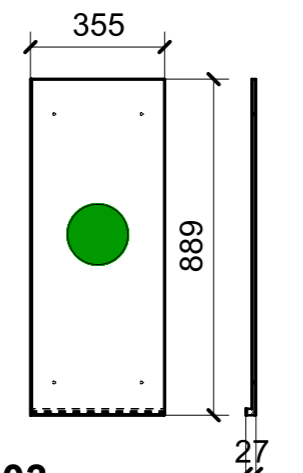

03

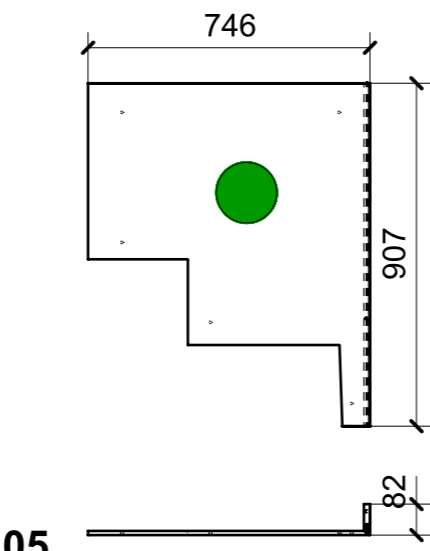

05

FERRAMENTA	QTY
BUSSOLA 5MA X 10 FORO DIAM.8	1

VERNICIATURA LASTRA/LACCATI:
 ● = VERNICIARE 1 LATO + FILI RASATI O BORDATI
 NESSUN SIMBOLO = VERNICIARE 2 LATI + FILI RASATI O BORDATI

LOCALE	CODICE	DESCRIZIONE COMPONENTE	FINITURA	GR.
LOBBY	MD298_R01_CC01	ARMADIO SOTTOSCALA	LASTRA CHIARA	8

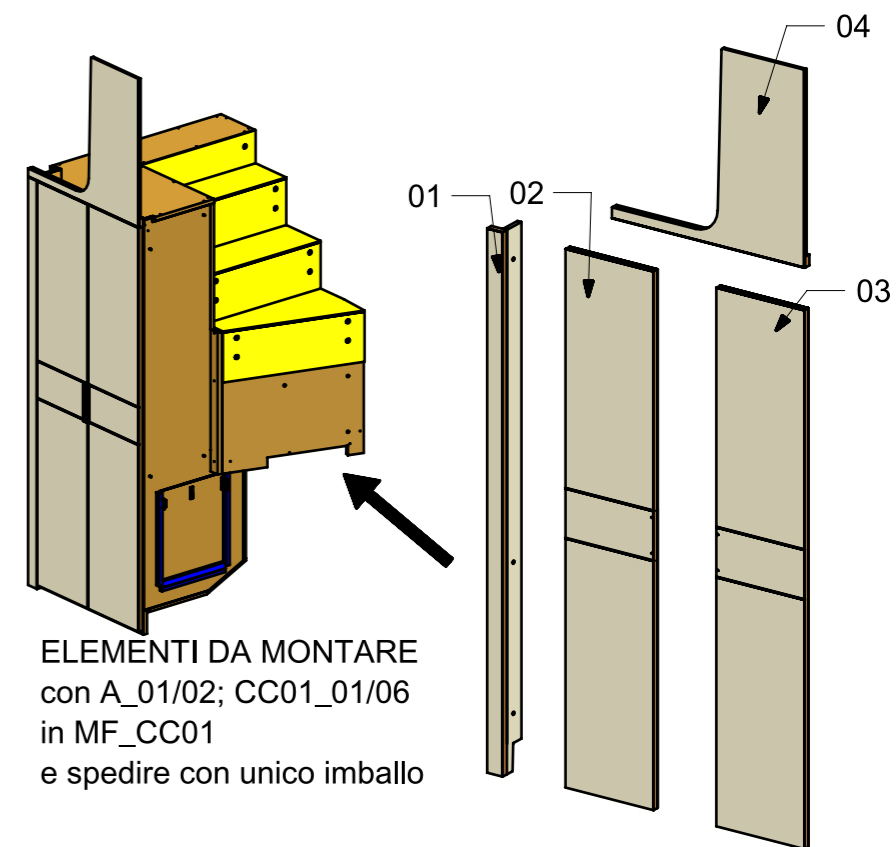
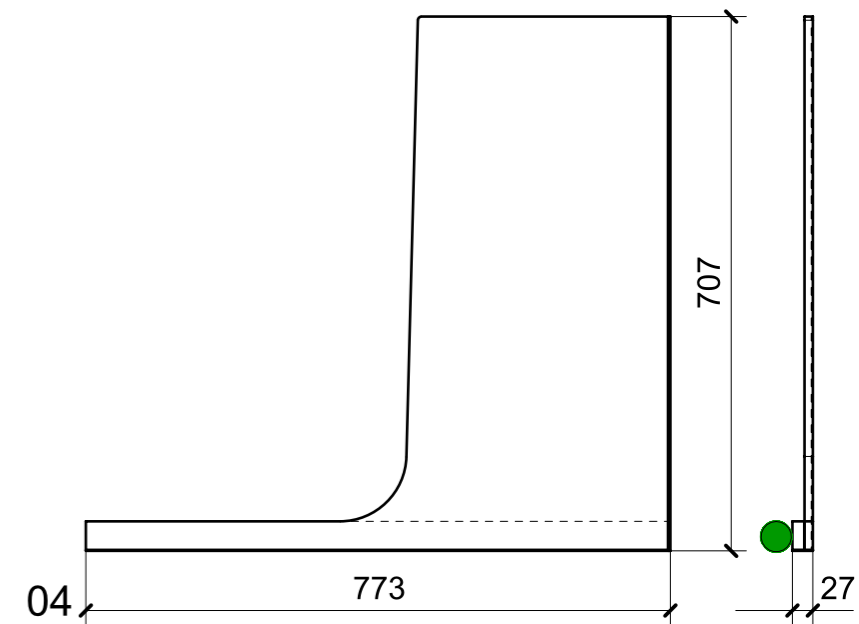
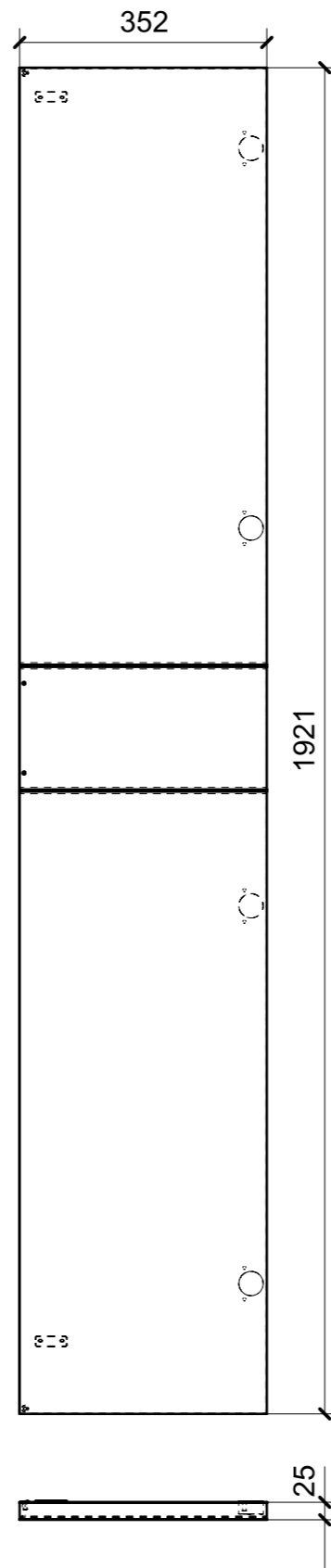
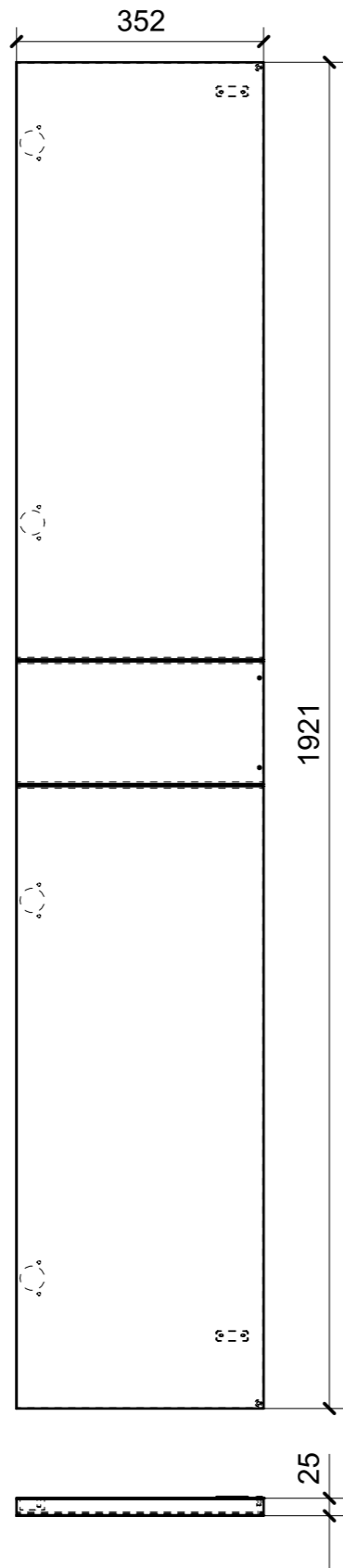
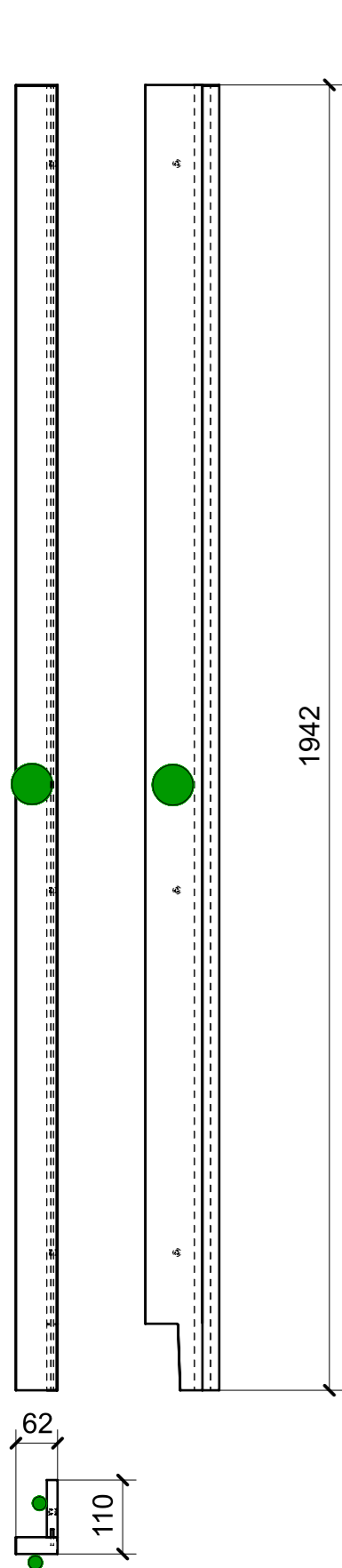

ELEMENTI DA MONTARE
con A_01/02; CC01_01/06
in MF_CC01
e spedire con unico imballo

01

FERRAMENTA	QTY
BUSSOLA 5MA X 10 FORO DIAM.8	3

FERRAMENTA	QTY
PLACCHETTA COUNTER STEEL_TECHNOPARTNER_MC-JM49	2
GOMMINO PARACOLPO ANTA	2

03

FERRAMENTA	QTY
GOMMINO PARACOLPO ANTA	2
PLACCHETTA COUNTER STEEL_TECHNOPARTNER_MC-JM49	2

VERNICIATURA LASTRA/LACCATI:

● = VERNICIARE 1 LATO + FILI RASATI O BORDATI

NESSUN SIMBOLO = VERNICIARE 2 LATI + FILI RASATI O BORDATI

LOCALE	CODICE	DESCRIZIONE COMPONENTE	FINITURA	Q.TA
LOBBY	MD298_R01_CN01	RIV. LATERALE PORTA ARMATORE	LASTRA CHIARA	1

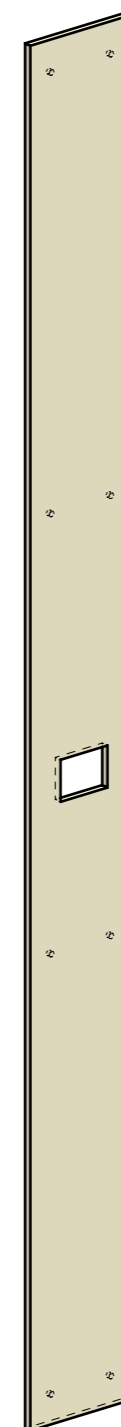
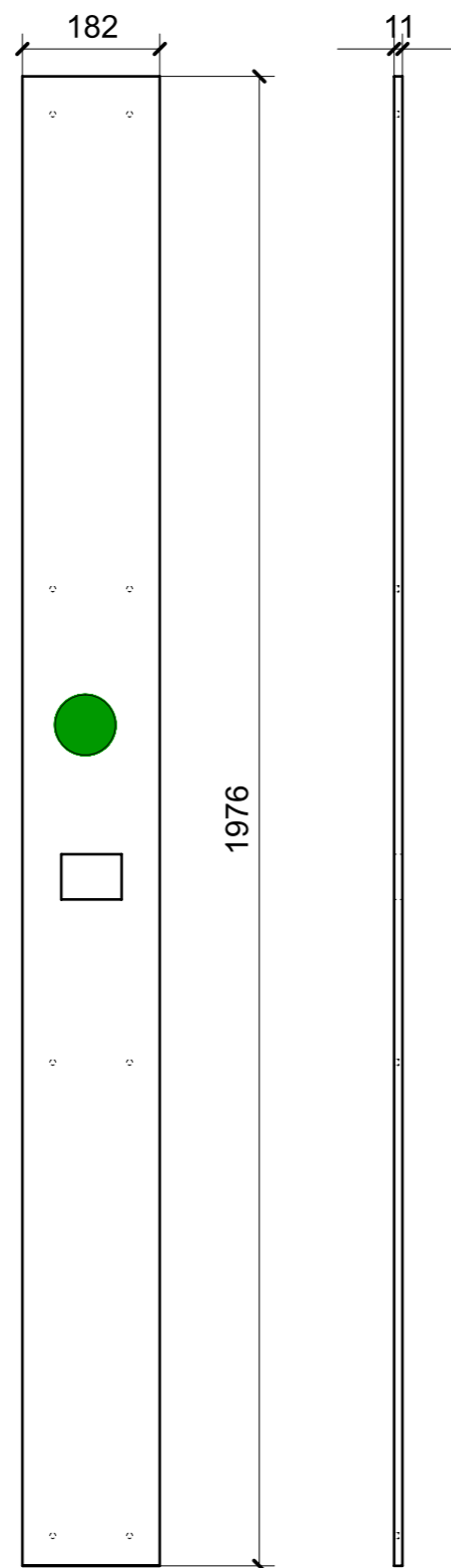

VERNICIATURA LASTRA/LACCATI:

● = VERNICIARE 1 LATO + FILI RASATI O BORDATI

NESSUN SIMBOLO = VERNICIARE 2 LATI + FILI RASATI O BORDATI

LOCALE	CODICE	DESCRIZIONE COMPONENTE	FINITURA	Q.TA
LOBBY	MD298_R01_CO01	RIV. PARATIA BAGNO VIP	LASTRA CHIARA	1

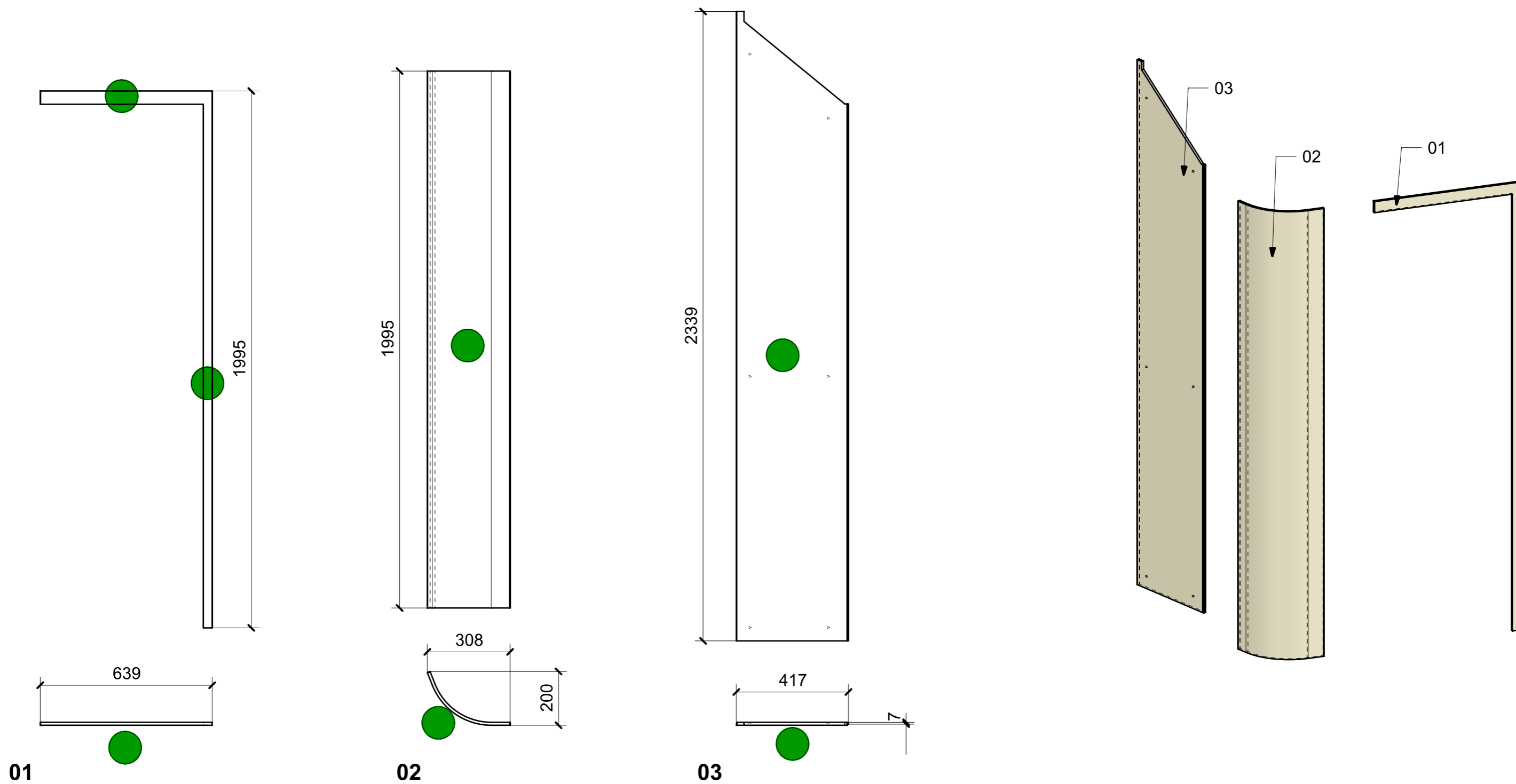

VERNICIATURA LASTRA/LACCATI:

● = VERNICIARE 1 LATO + FILI RASATI O BORDATI

NESSUN SIMBOLO = VERNICIARE 2 LATI + FILI RASATI O BORDATI

LOCALE	CODICE	DESCRIZIONE COMPONENTE	FINITURA	Q.TA
LOBBY	MD298_R01_CP01	RIV. TELAIO PORTA OSPITI	LASTRA CHIARA	1

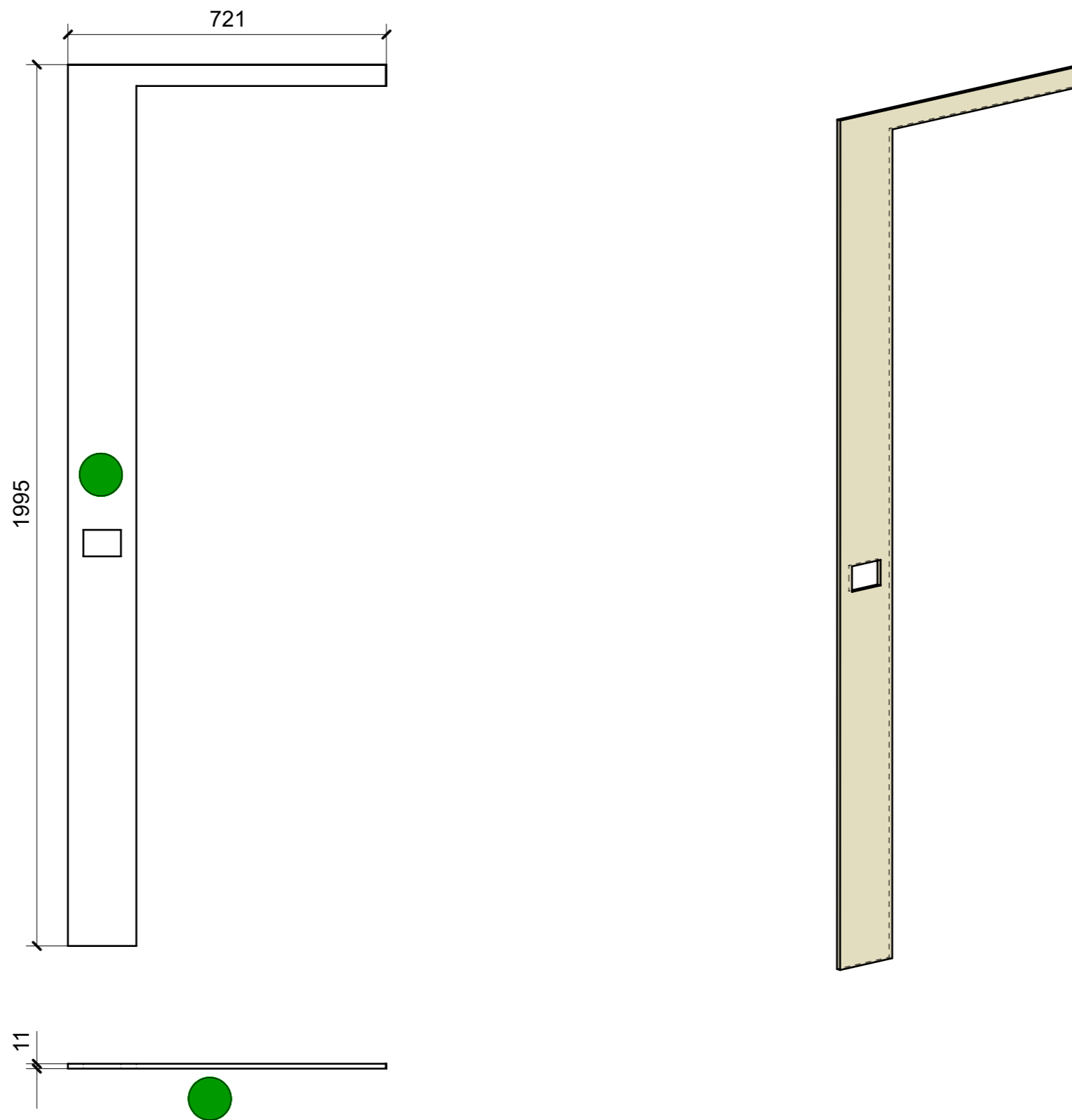

VERNICIATURA LASTRA/LACCATI:

● = VERNICIARE 1 LATO + FILI RASATI O BORDATI

NESSUN SIMBOLO = VERNICIARE 2 LATI + FILI RASATI O BORDATI

LOCALE	CODICE	DESCRIZIONE COMPONENTE	FINITURA	GR.
LOBBY	MD298_R01_CR01	SOGLIA GRADINO IN LASTRA	LASTRA CHIARA	gr7

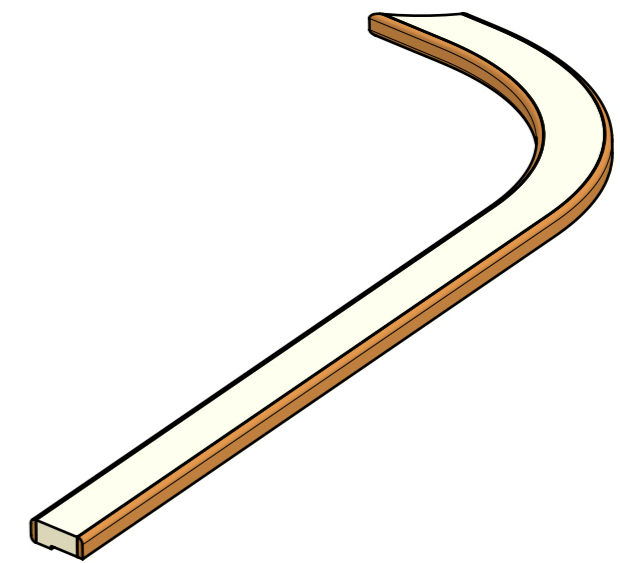
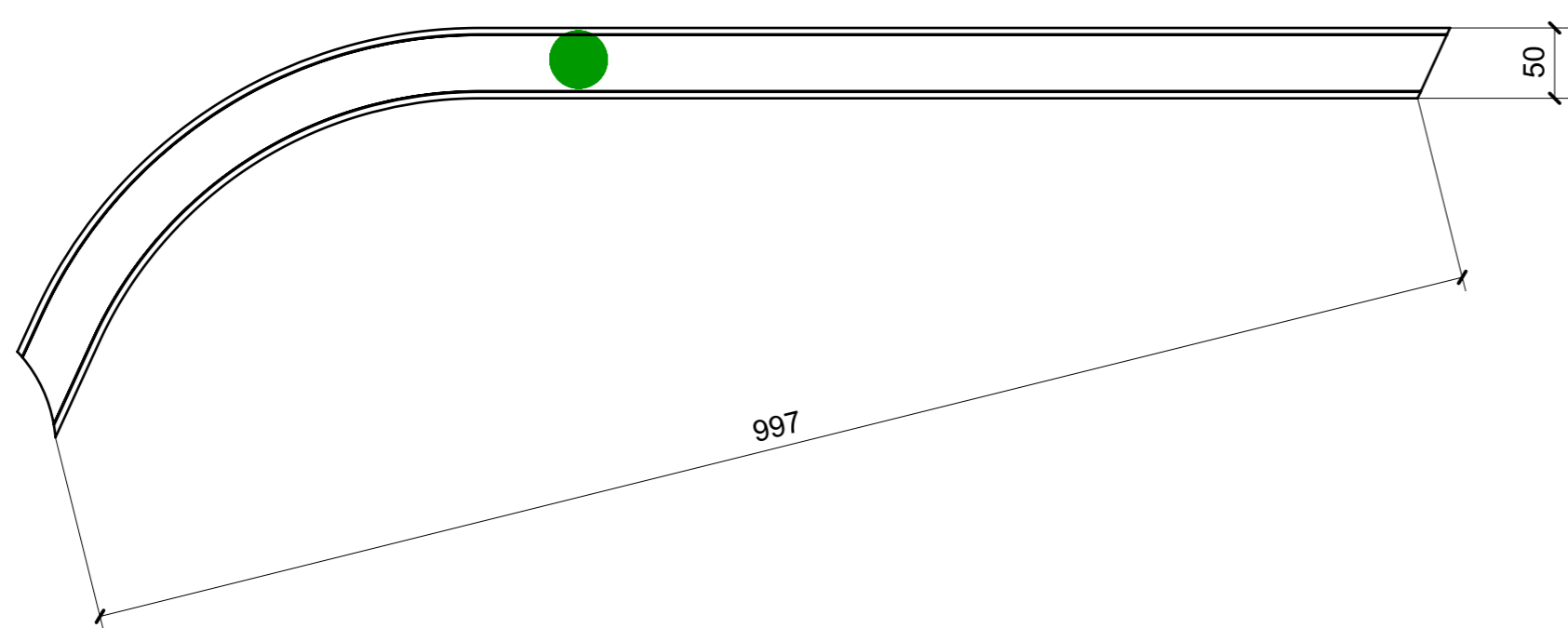

01

VERNICIATURA LASTRA/LACCATI:
 ● = VERNICIARE 1 LATO + FILI RASATI O BORDATI NESSUN SIMBOLO = VERNICIARE 2 LATI + FILI RASATI O BORDATI