

LOCALE	CODICE	DESCRIZIONE COMPONENTE	FINITURA	Q.TA
CABINA ARMATORE	MD298_AA01	STRUTTURA MURATA DX	OKOUME' GREZZO	1

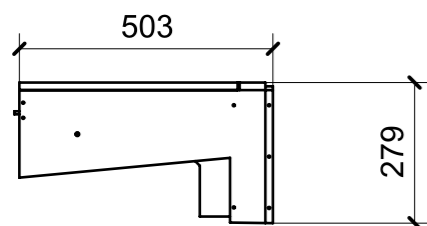

01

FERRAMENTA	QTY
VITE 6MA X 25 TESTA BOMBATA	4
FITLOCK F_MASCHERPA_6020101102	6

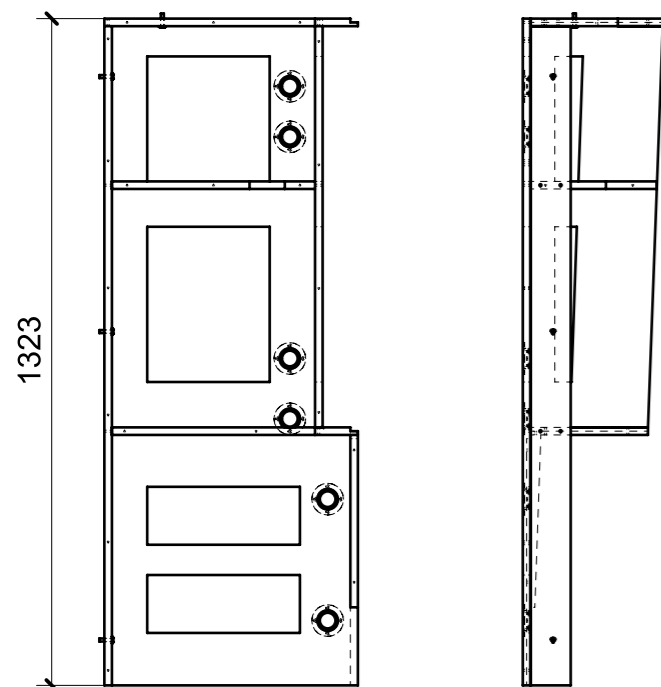
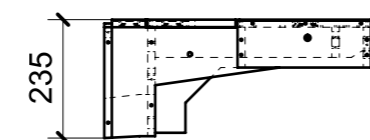
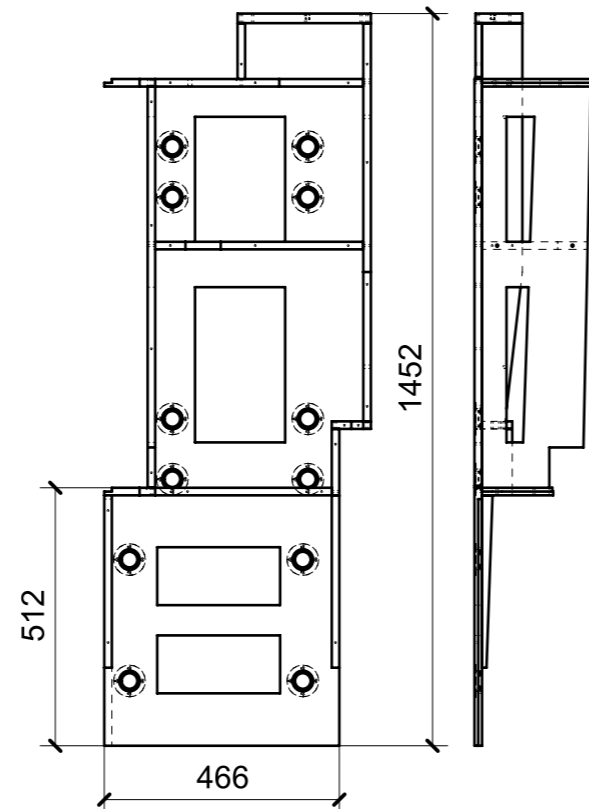

03

FERRAMENTA	QTY
BUSSOLA 6MA X 10 FORO DIAM.8	1
FITLOCK F_MASCHERPA_6020101102	12

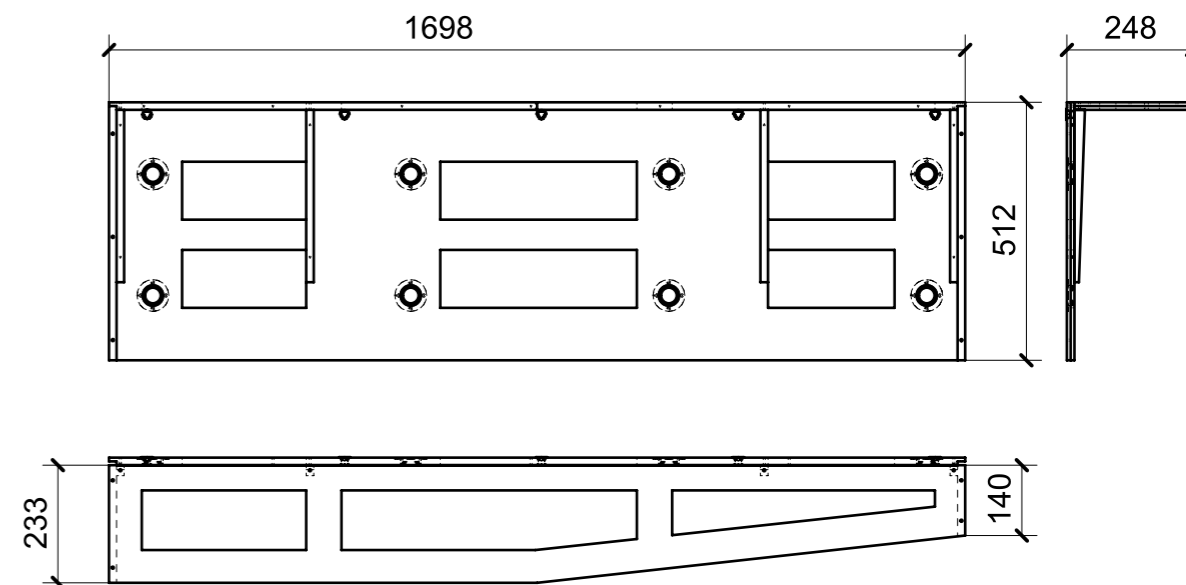

04

FERRAMENTA	QTY
FM INCASSO_ITALVIPLA_973_FMPC_F1A	5
FITLOCK F_MASCHERPA_6020101102	8

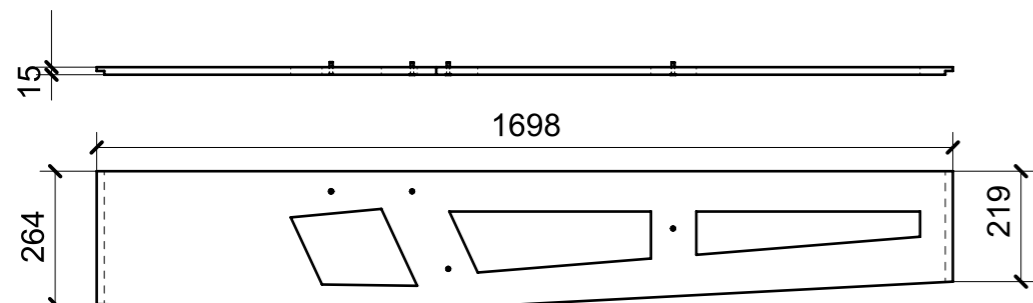

02

FERRAMENTA	QTY
VITE 6MA X 25 TESTA SVASATA	4

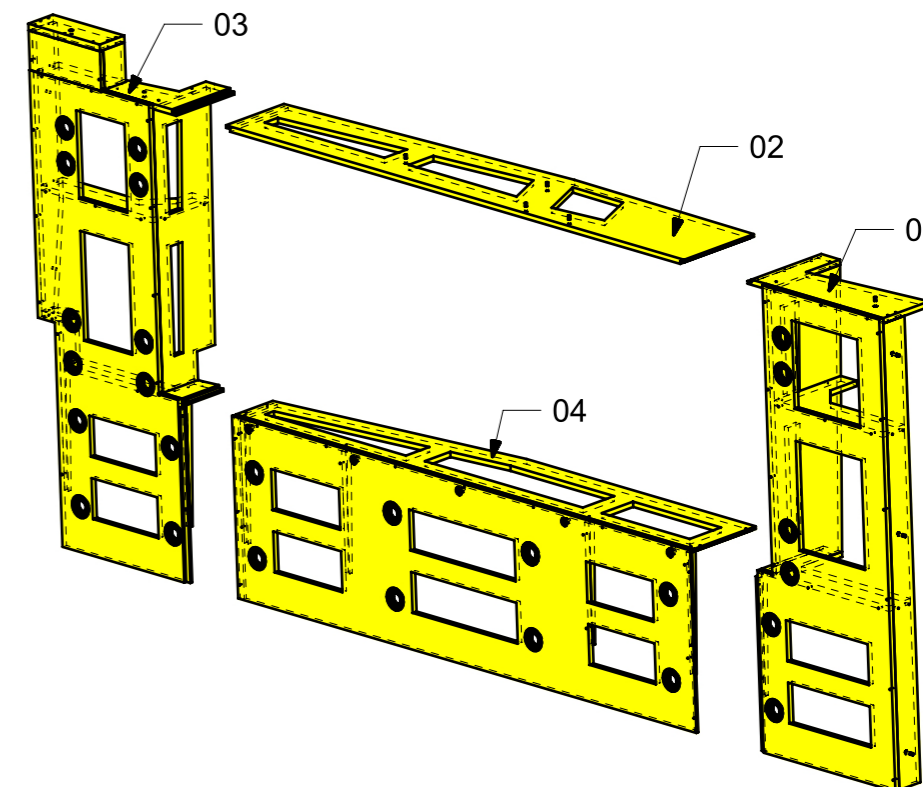

LOCALE	CODICE	DESCRIZIONE COMPONENTE	FINITURA	Q.TA
CABINA ARMATORE	MD298_AB01	RACCORDO POPPIERO MURATA DX	OKUME' GREZZO	1

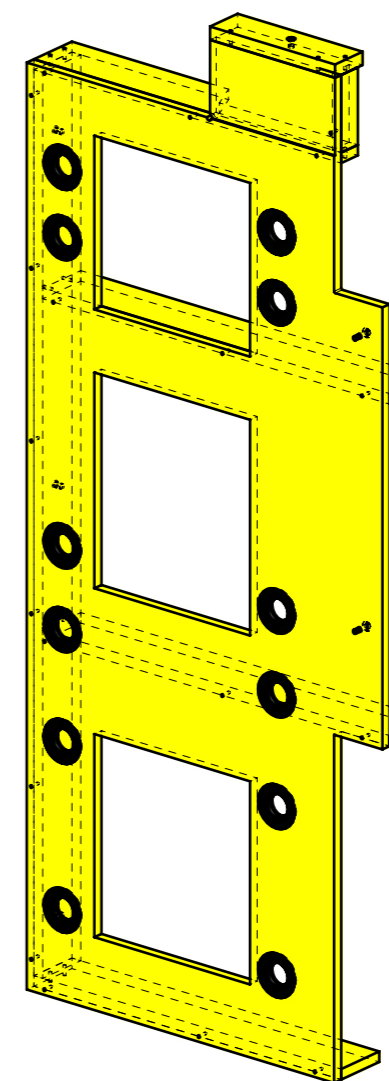
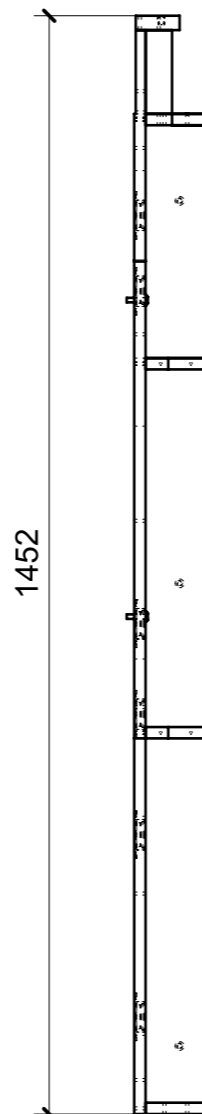
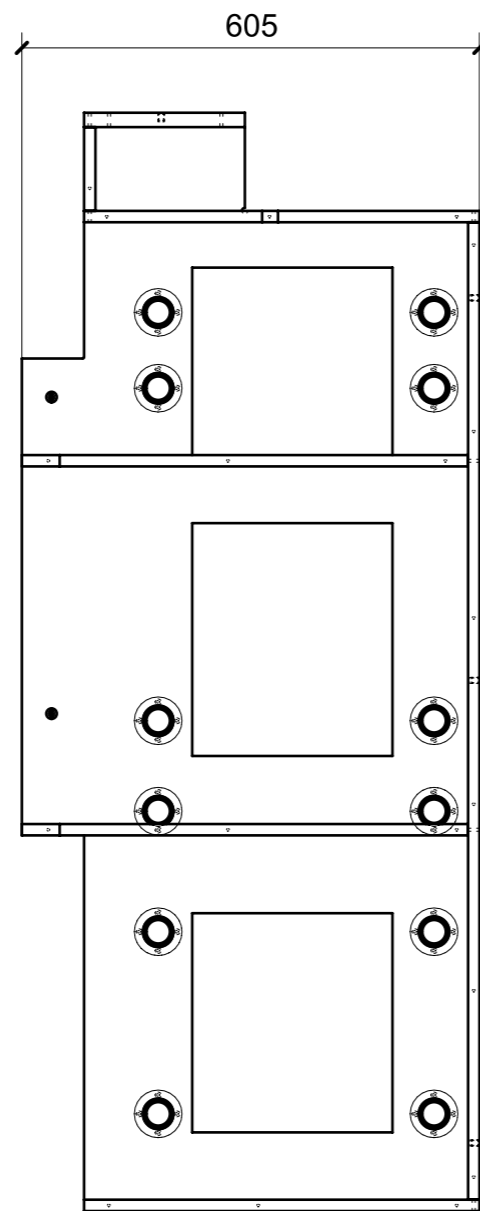

FERRAMENTA	QTY
BUSSOLA 6MA X 10 FORO DIAM.8	4
FITLOCK F_MASCHERPA_6020101102	12
VITE 6MA X 25 TESTA BOMBATA	2

LOCALE	CODICE	DESCRIZIONE COMPONENTE	FINITURA	Q.TA
CABINA ARMATORE	MD298_AC01	PLENUM MURATA	VERNICIATI ANTI ROMBO	1

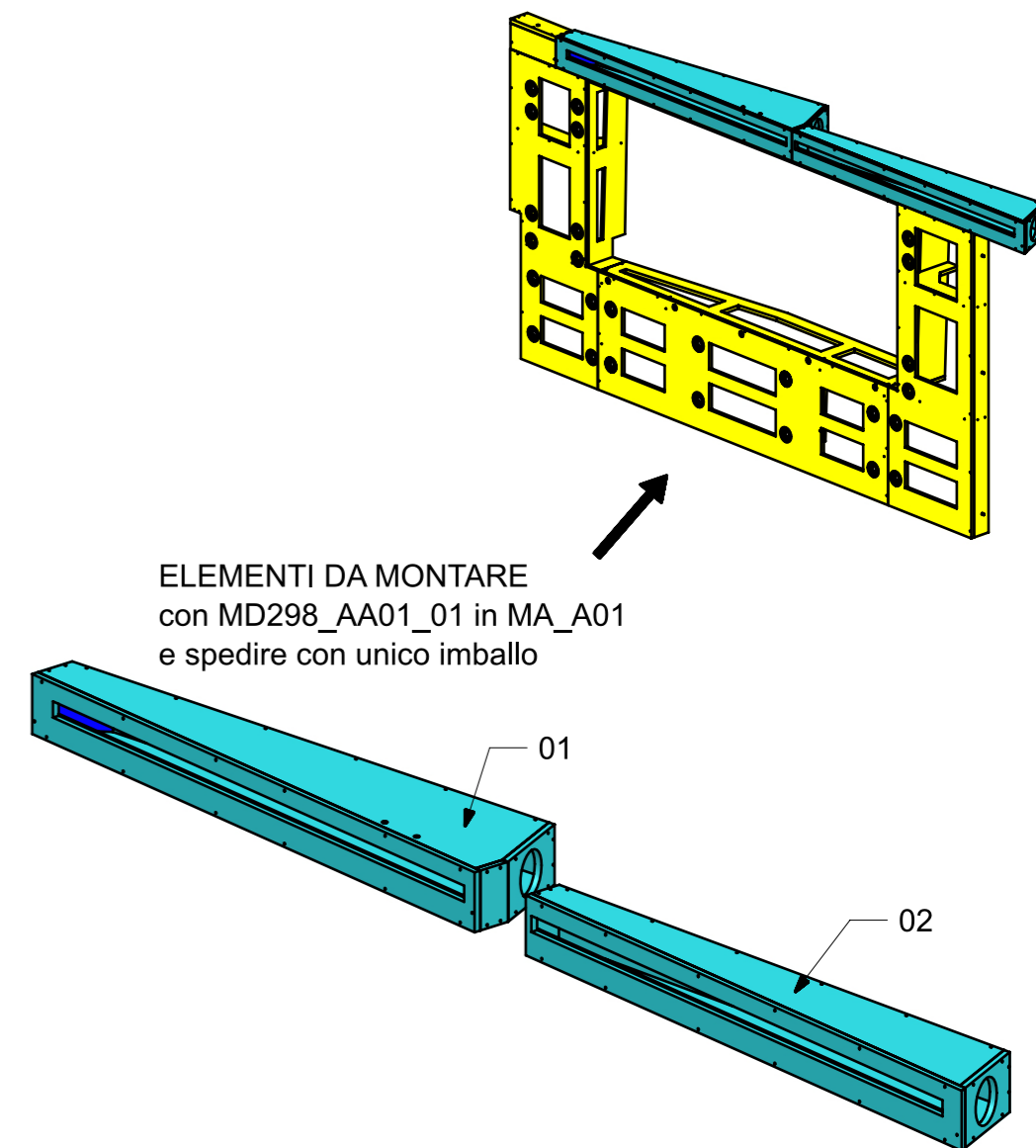
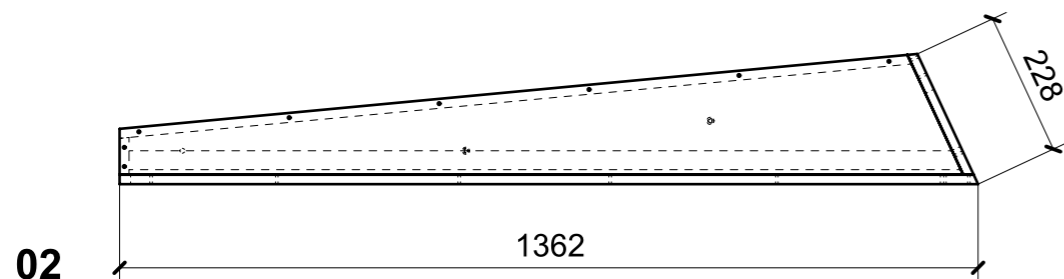
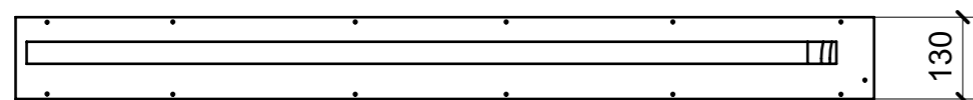
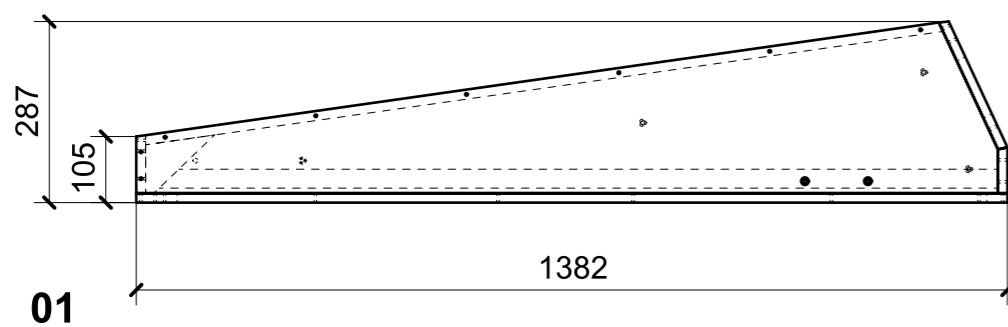
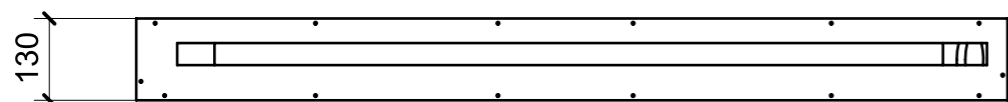

ELEMENTI DA MONTARE
 con MD298_AA01_01 in MA_A01
 e spedire con unico imballo

FERRAMENTA	QTY
BUSSOLA 6MA X 10 FORO DIAM.8	16

LOCALE	CODICE	DESCRIZIONE COMPONENTE	FINITURA	GR.
CABINA ARMATORE	MD298_AD01	ARMADIO	LAMINATO LG23 PORO ROVERE\GREZZO\MDF	8

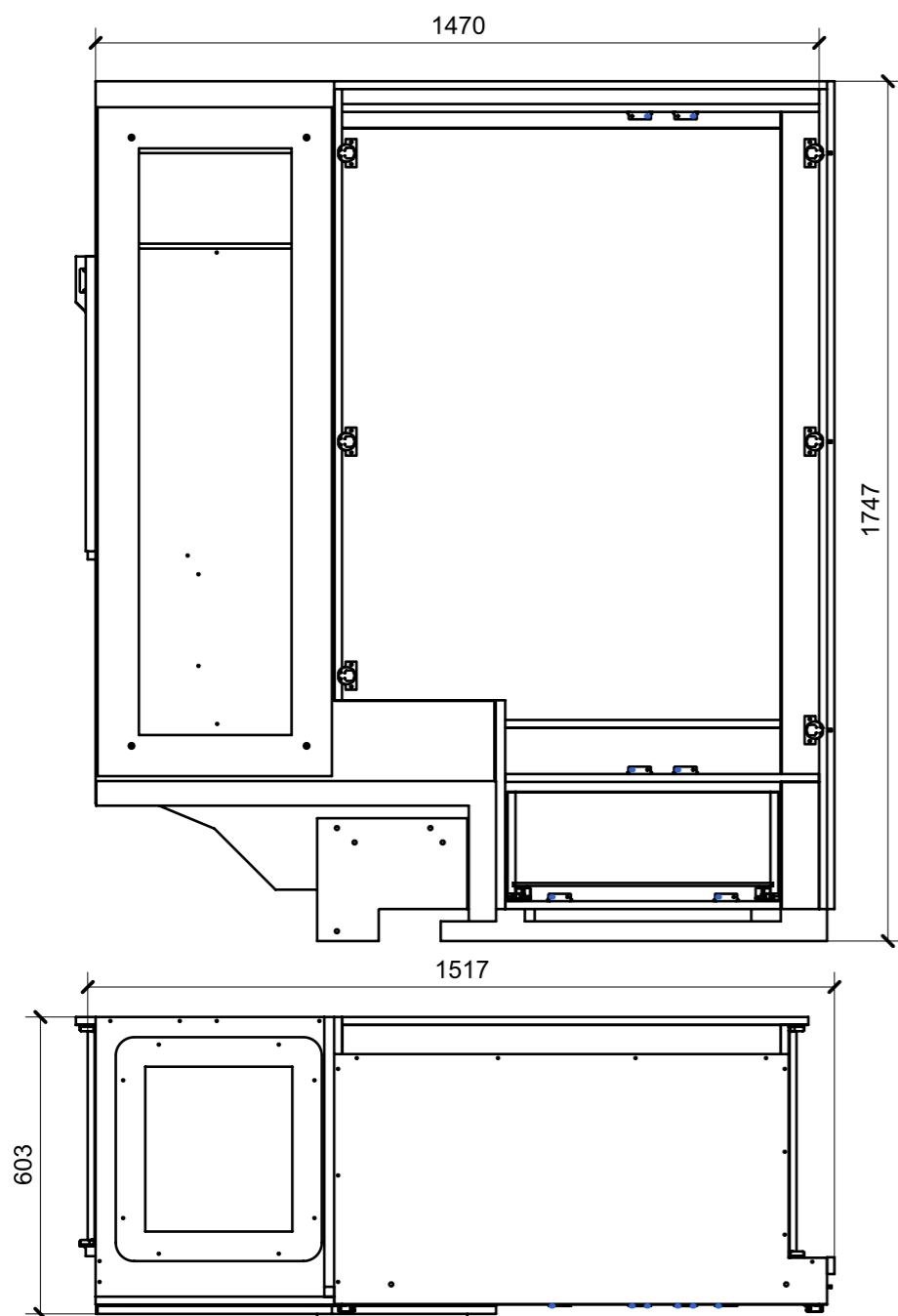

01

FERRAMENTA	QTY
ALZAPAGLIOLI_FORESTI_164.C	1
CP GUIDA TANDEMPUS 450_HAFELE_423_54_745	1
BASE_3-NERA_HAFELE_342.22.067-BLUM_175H3130.STP	6
CERNIERA 94°_PIANA-NERA_HAFELE_342.46.604-BLUM_71B9550.STP	6
CHIUSURA A SPINTA_TECHNOPARTNER_SOU C3-203	8
VITE 5MA X 25 TESTA SVASATA	3
PLACCHETTA COUNTER STEEL_TECHNOPARTNER_MC-JM49	6
CALAMITA SEALED MAGNETIC_TECNOPARTNER_MC-JM50-BL	6
VITE 6MA X 25 TESTA SVASATA	4

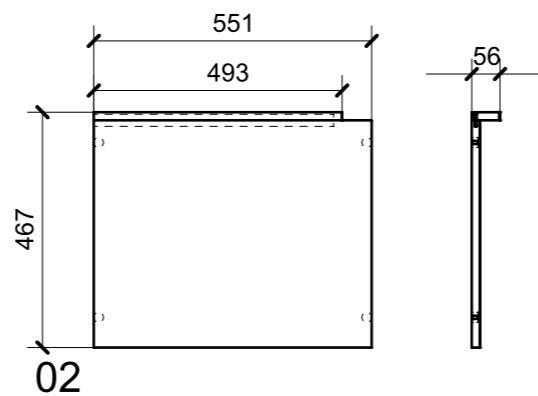

02

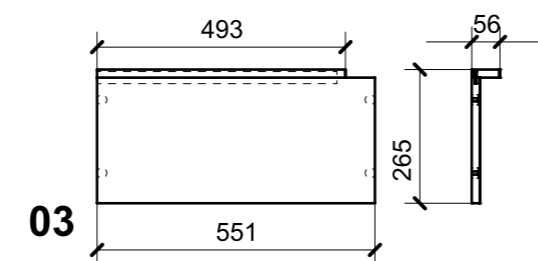

03

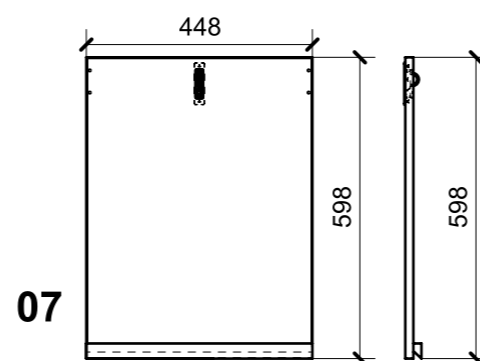

07

FERRAMENTA	QTY
ALZAPAGLIOLI_FORESTI_164.C	1

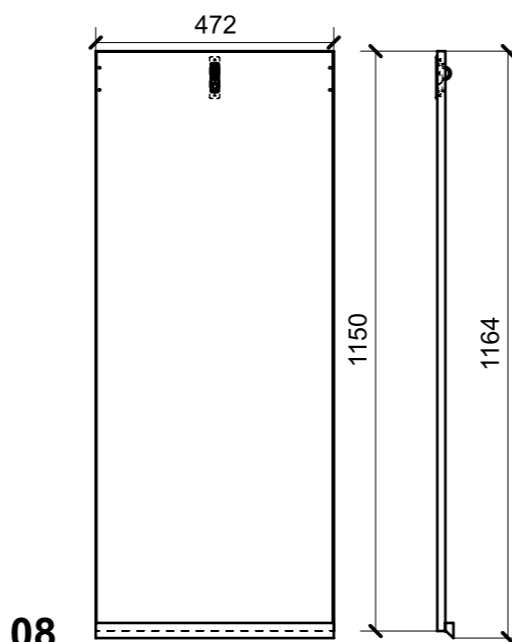

08

FERRAMENTA	QTY
ALZAPAGLIOLI_FORESTI_164.C	1

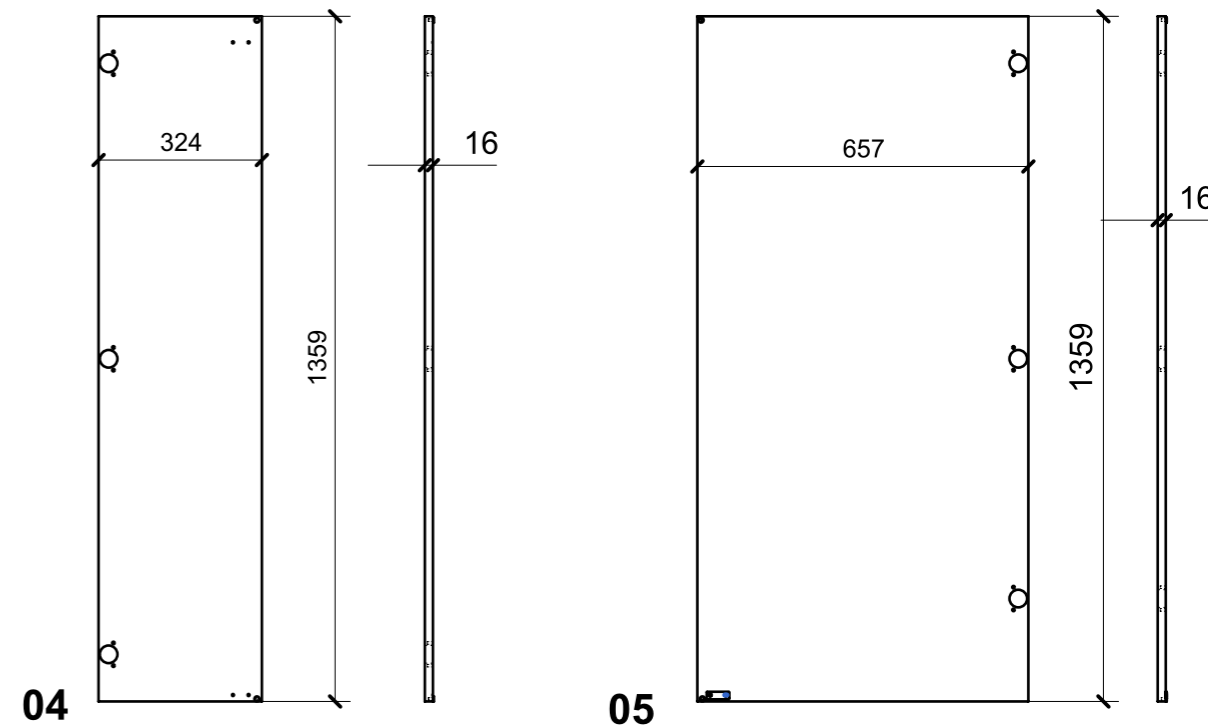

04

05

FERRAMENTA	QTY
GOMMINO PARACOLPO ANTA	4
PLACCHETTA COUNTER STEEL_TECHNOPARTNER_MC-JM49	1

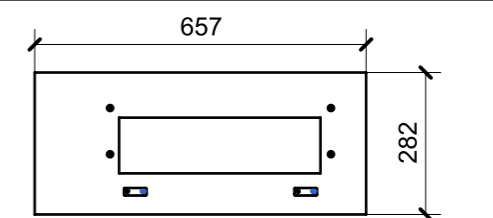

06

FERRAMENTA	QTY
PLACCHETTA COUNTER STEEL_TECHNOPARTNER_MC-JM49	2
BUSSOLA 6MA X 10 FORO DIAM.8	8

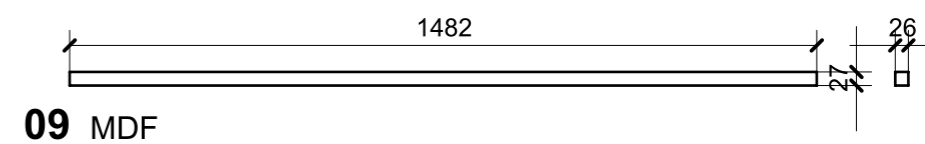

09 MDF

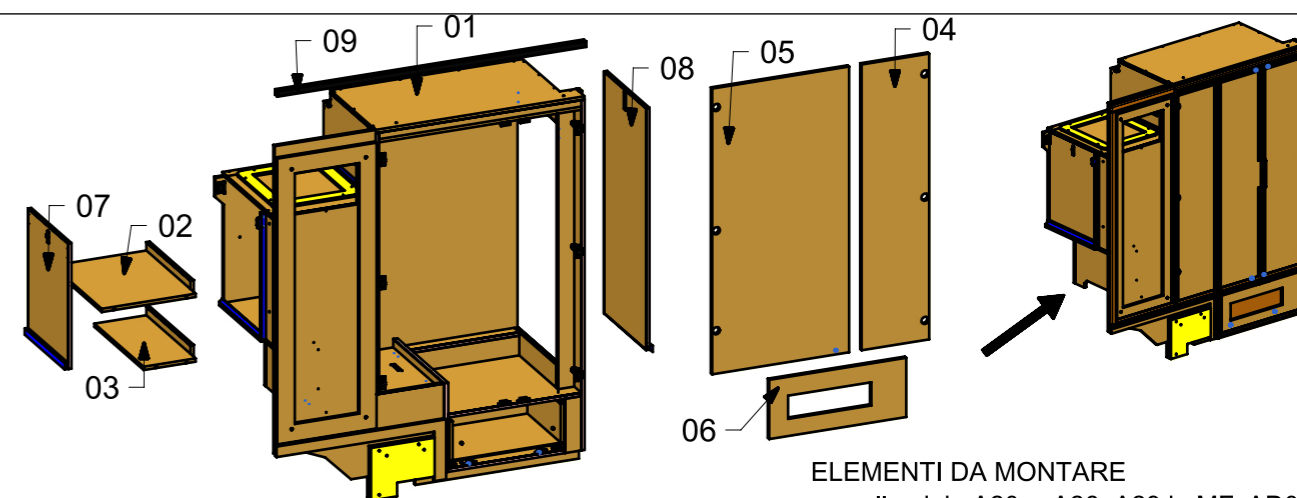

ELEMENTI DA MONTARE
con alluminio A20→A26; A29 in MF_AD01
e spedire con unico imballo

LOCALE	CODICE	DESCRIZIONE COMPONENTE	FINITURA	Q.TA
CABINA ARMATORE	MD298_AE01	STRUTTURA MURATA SX	OKUME' GREZZO	1

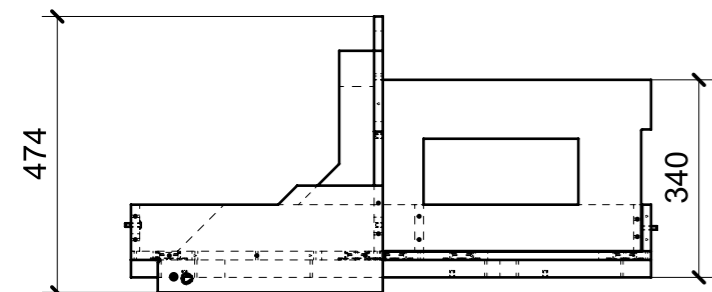
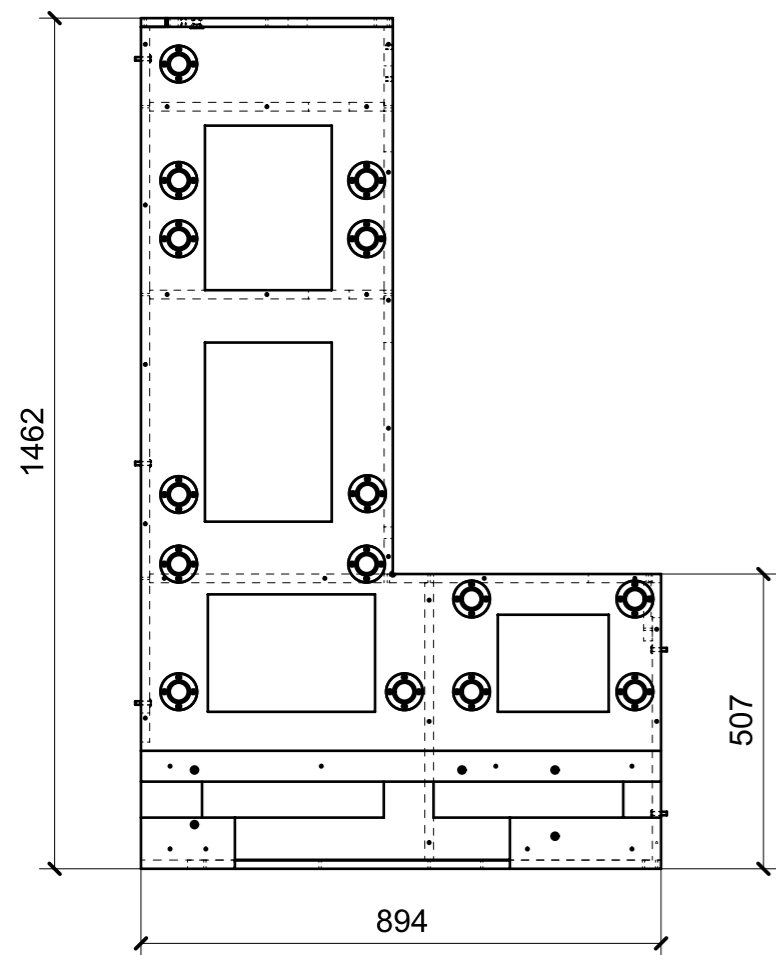

01

FERRAMENTA	QTY
BUSSOLA 5MA X 10 FORO DIAM.8	5
BUSSOLA 6MA X 10 FORO DIAM.8	4
FITLOCK F_MASCHERPA_6020101102	15
FM INCASSO_ITALVIPLA_973_FMPC_F1A	1
VITE 6MA X 25 TESTA BOMBATA	5

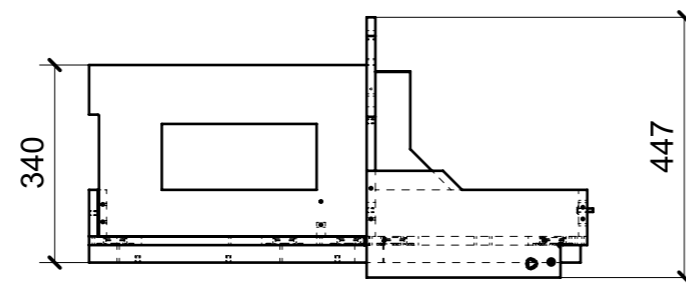
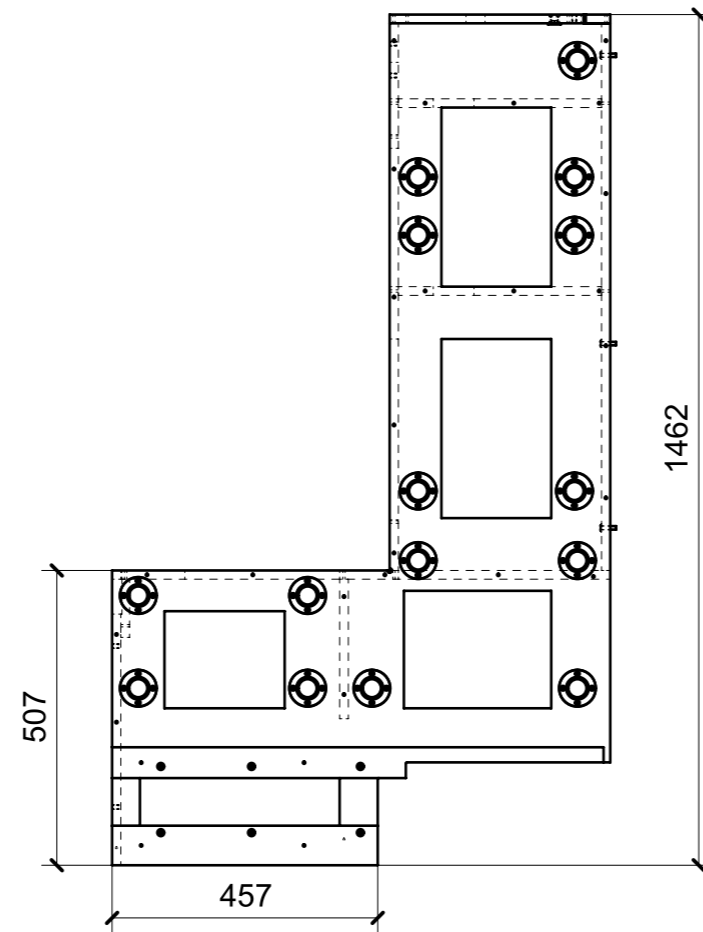

02

FERRAMENTA	QTY
BUSSOLA 5MA X 10 FORO DIAM.8	6
BUSSOLA 6MA X 10 FORO DIAM.8	6
FITLOCK F_MASCHERPA_6020101102	15
FM INCASSO_ITALVIPLA_973_FMPC_F1A	1
VITE 6MA X 25 TESTA BOMBATA	3

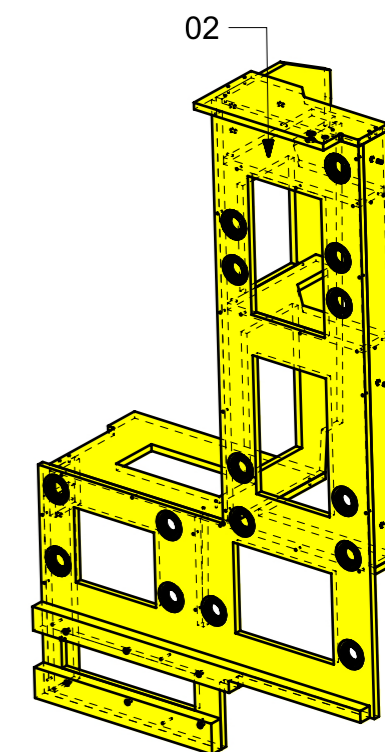
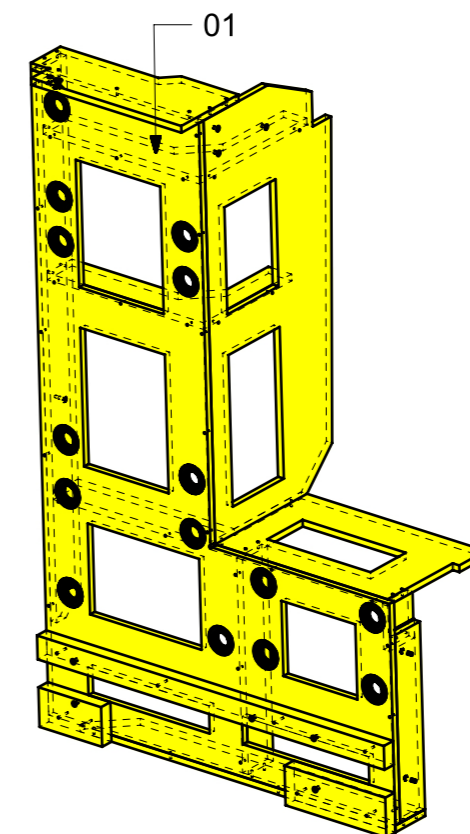

LOCALE	CODICE	DESCRIZIONE COMPONENTE	FINITURA	Q.TA
CABINA ARMATORE	MD298_AF01	STRUTTURA A PONTE MURATA SX	OKUME' GREZZO	1

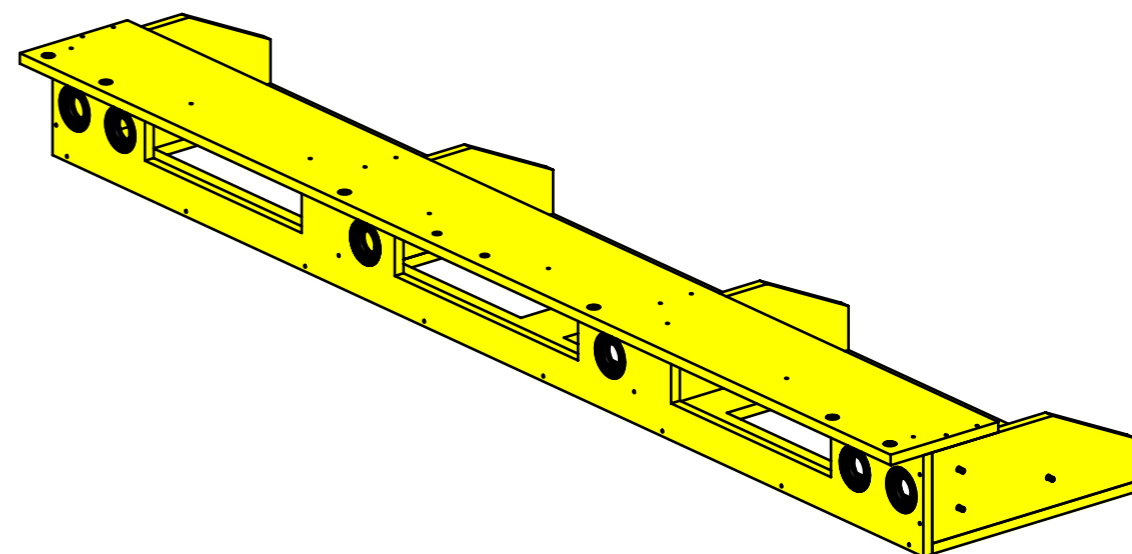
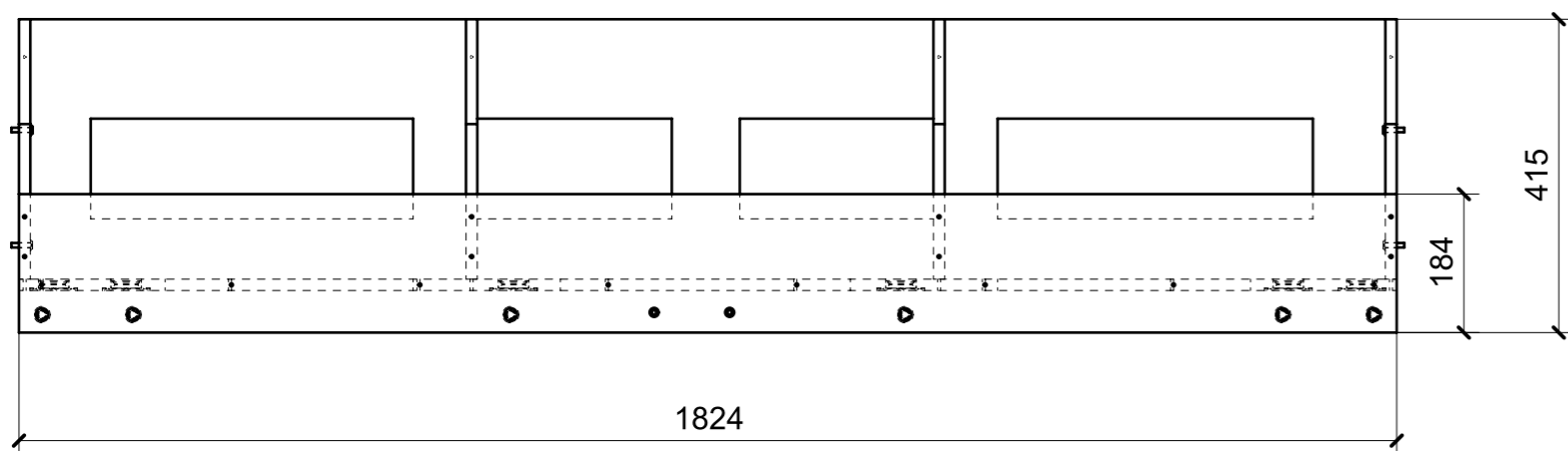
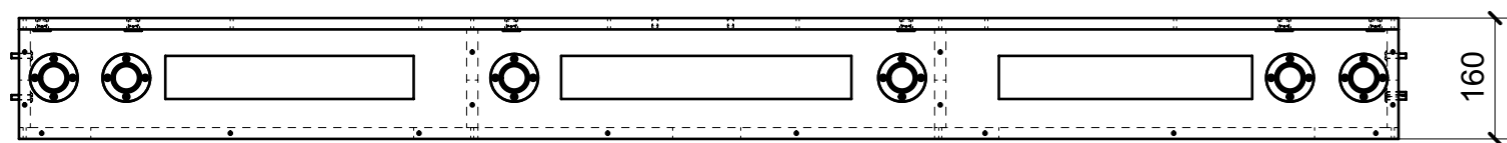

FERRAMENTA	QTY
BUSSOLA 6MA X 10 FORO DIAM.8	2
FITLOCK F_MASCHERPA_6020101102	6
FM INCASSO_ITALVIPLA_973_FMPC_F1A	6
VITE 6MA X 25 TESTA BOMBATA	6

LOCALE	CODICE	DESCRIZIONE COMPONENTE	FINITURA	GR
CABINA ARMATORE	MD298_AG01	CASSA TV	LAMINATO LG23 PORO ROVERE	8

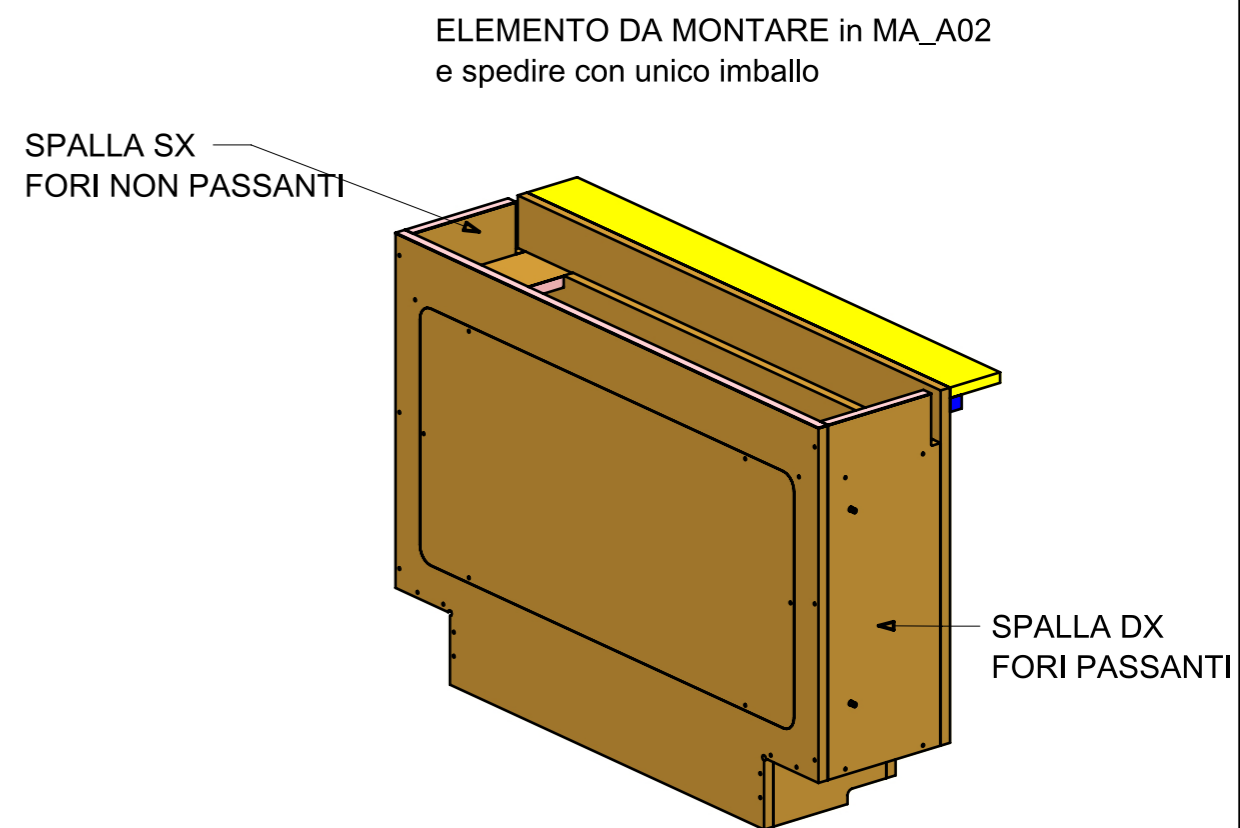
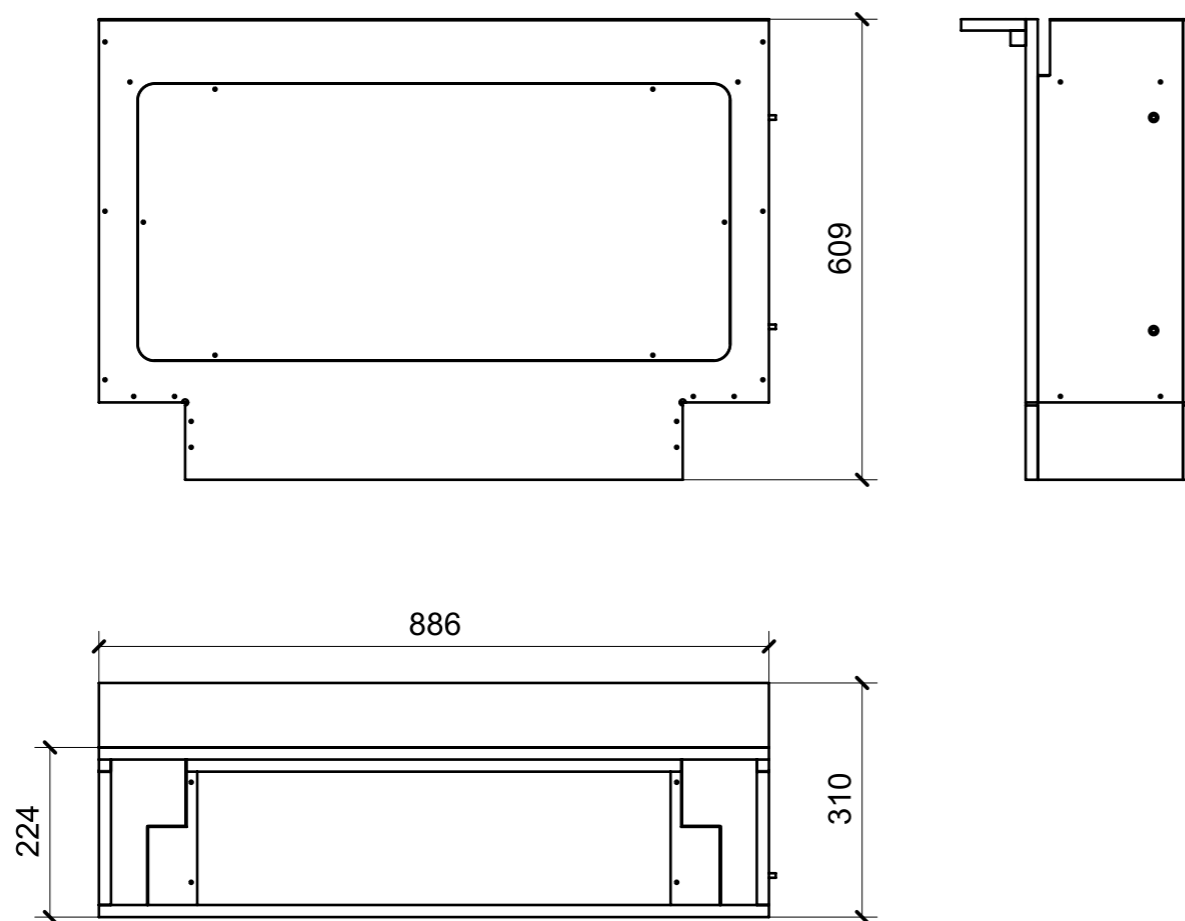

FERRAMENTA	QTY
BUSSOLA 6MA X 10 FORO DIAM.8	2
VITE 6MA X 25 TESTA BOMBATA	2

LOCALE	CODICE	DESCRIZIONE COMPONENTE	FINITURA	Q.TA
CABINA ARMATORE	MD298_AH01	LETTO	LAMINATO LG23 PORO ROVERE\GREZZO\GOFFRATONE	1

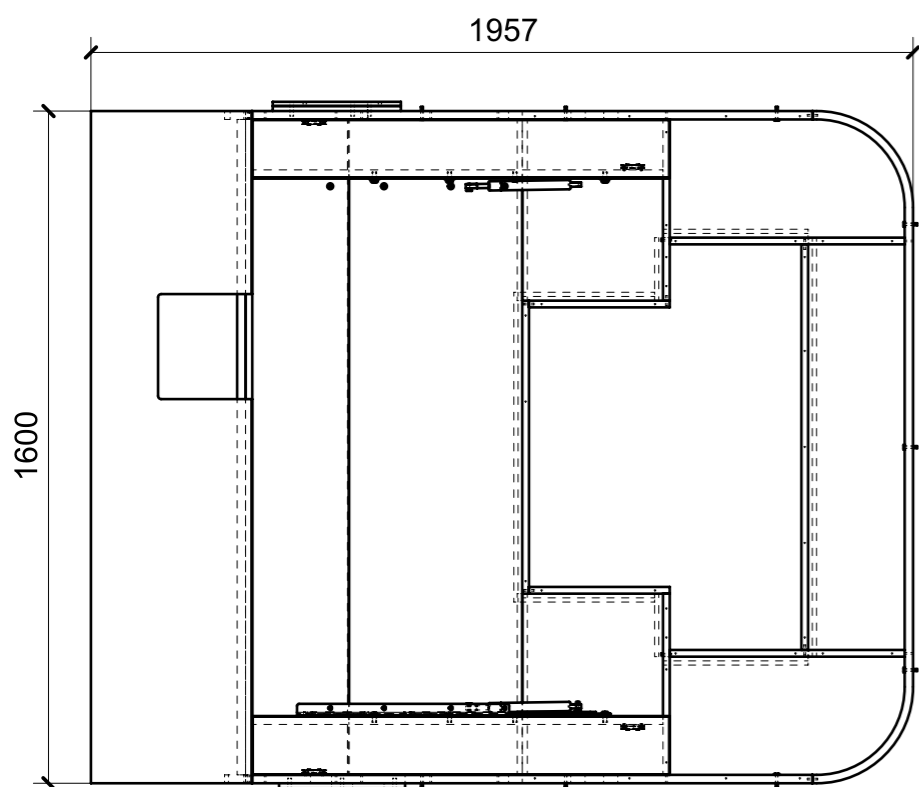
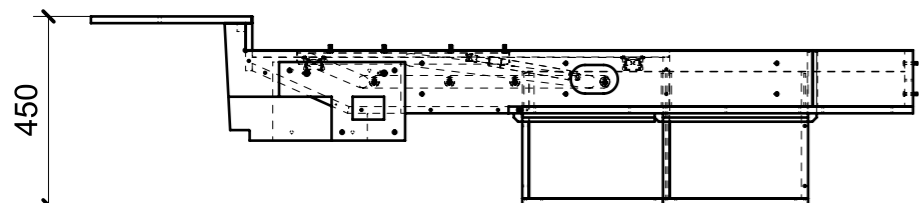

01

FERRAMENTA	QTY
SEEGER PER MECC. LETTO_00407908	2
PISTONE A GAS STABILUS_456306_600NW-L385_FBC_99999049	2
TBL 8MA X 20_FBC	8
CP TRAPEZI STABILUS TZ 530 BTZ T2.A0_FBC_99999032	1
BUSSOLA 8MA X 14_FBC	8
CHIUSURA A SPINTA_TECHNOPARTNER_SOU C3-203	4
RANELLA SP.2 MM DIAM.24 FORO 8_FBC	8
BUSSOLA 6MA X 10 FORO DIAM.8	4
TBL 6MAX15_FBC	8
VITE 5MA X 30 TESTA BOMBATA	18

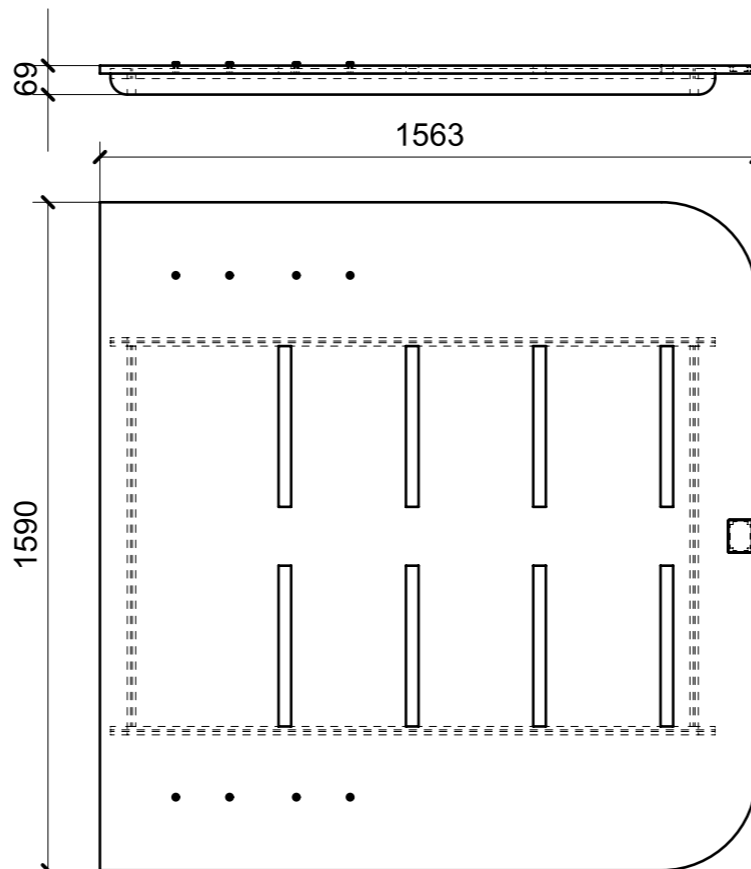

02

FERRAMENTA	QTY
MANIGLIETTA ALZA LETTO_FORESTI_ART.76A.C	1
BORCHIA PASSO 6MA_FBC	8

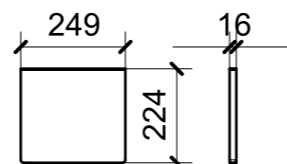

03

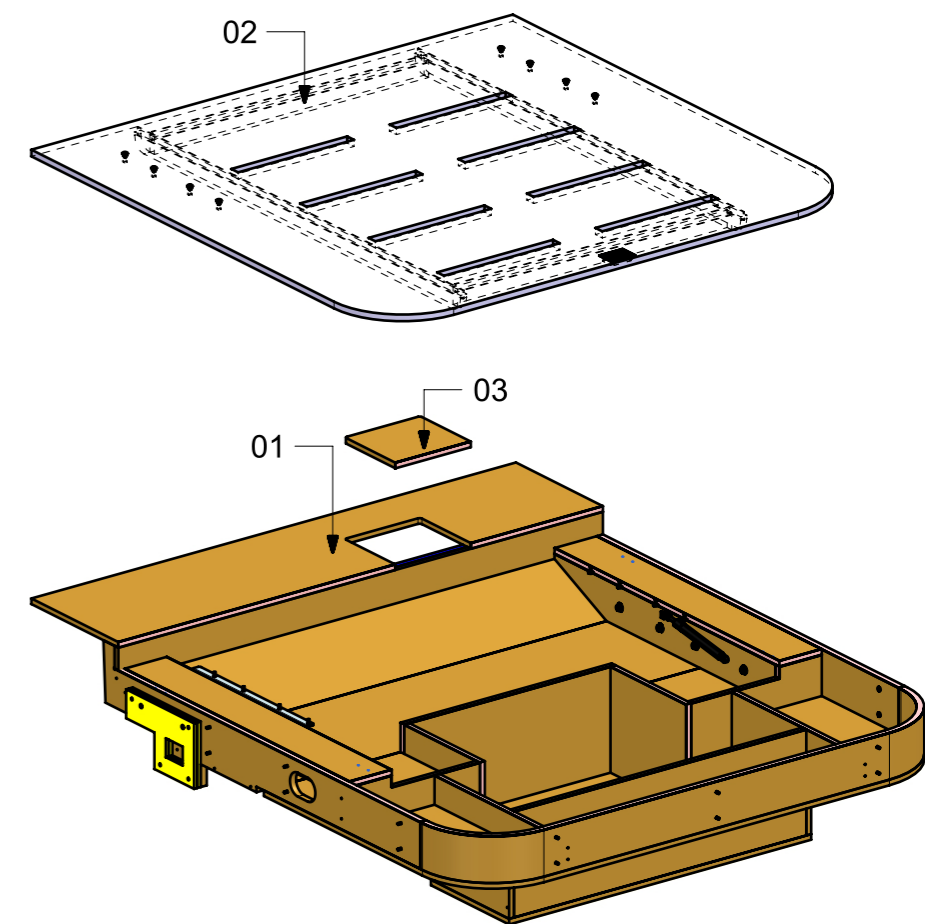

LOCALE	CODICE	DESCRIZIONE COMPONENTE	FINITURA	GR.
CABINA ARMATORE	MD298_AI01	COMODINO PRODIERO	LAMINATO LG23 PORO ROVERE/GREZZO	06

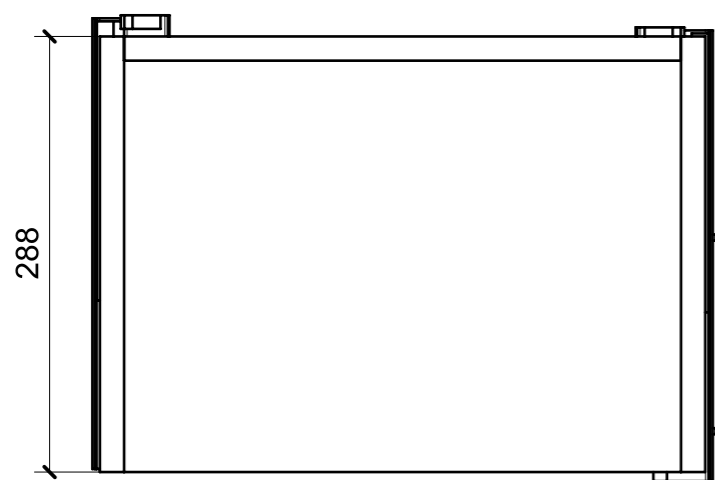
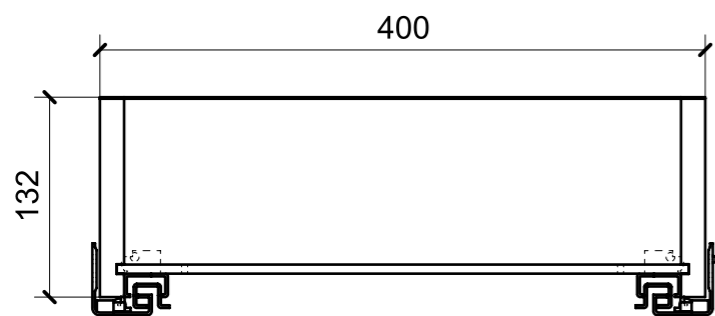

01

FERRAMENTA	QTY
CP GUIDA TANDEMPLUS 300_HAFELE_423_54_730_ESSEPI_00175852	1

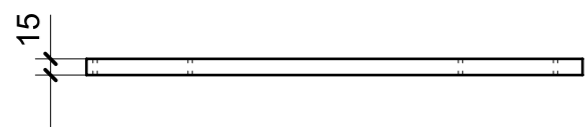
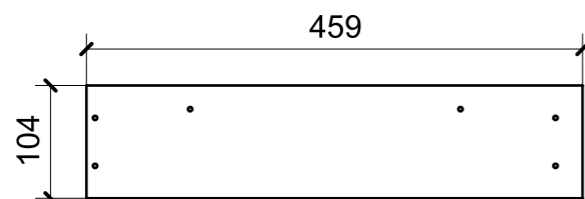

02

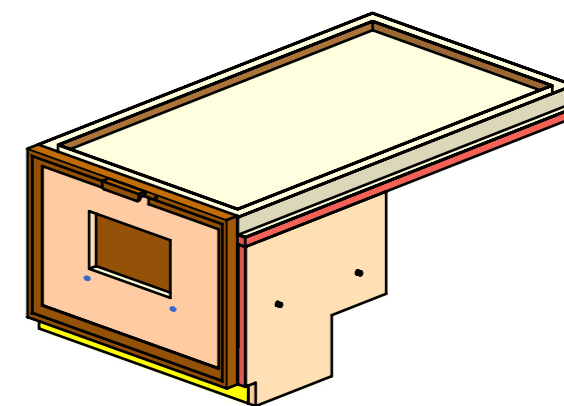

ELEMENTI DA MONTARE
 con R01_AI_01_01-02; X01_AI01_01
 A01_AI01-13/14 in MF_AI01
 e spedire con unico imballo

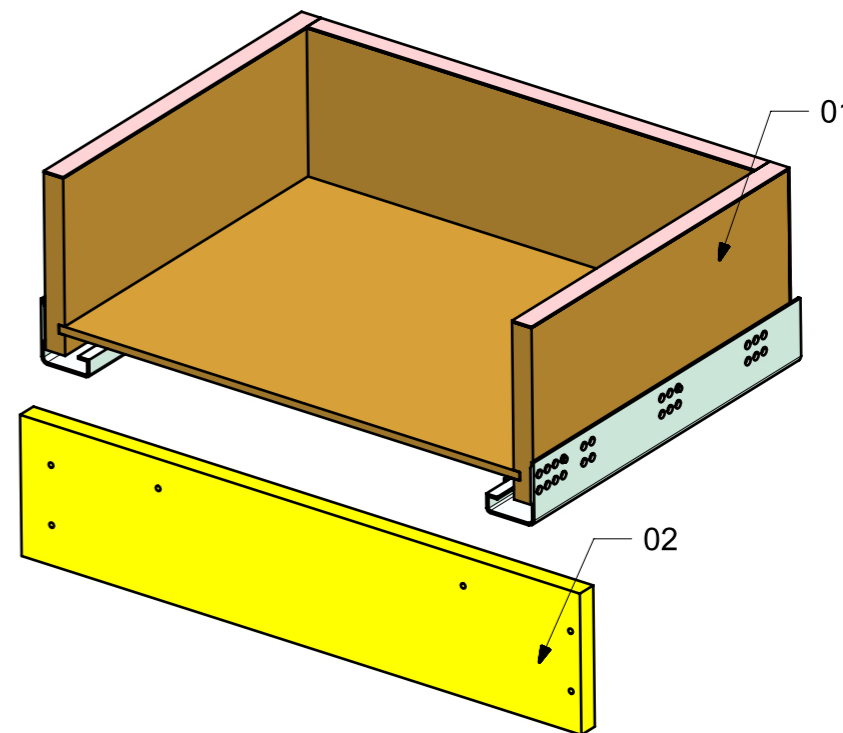

LOCALE	CODICE	DESCRIZIONE COMPONENTE	FINITURA	GR.
CABINA ARMATORE	MD298_AL01	COMODINO POPPIERO	LAMINATO LG23 PORO ROVERE	06

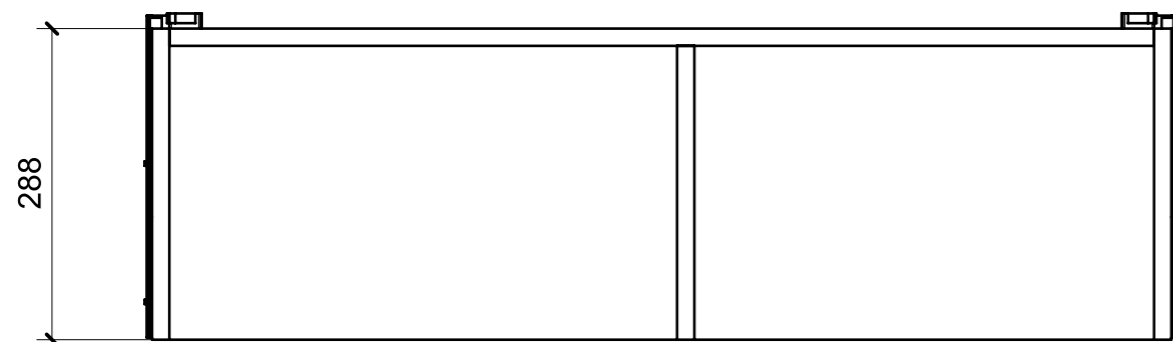
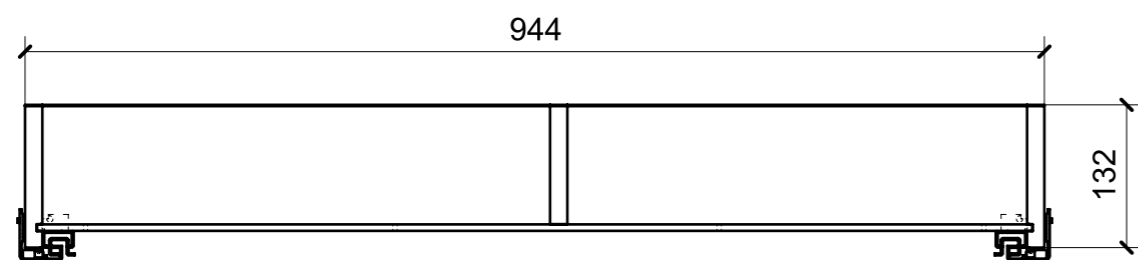

ELEMENTO DA MONTARE
 con R01_AL01_01-02; X01_AL01_01 in MF_AL01
 e spedire con unico imballo

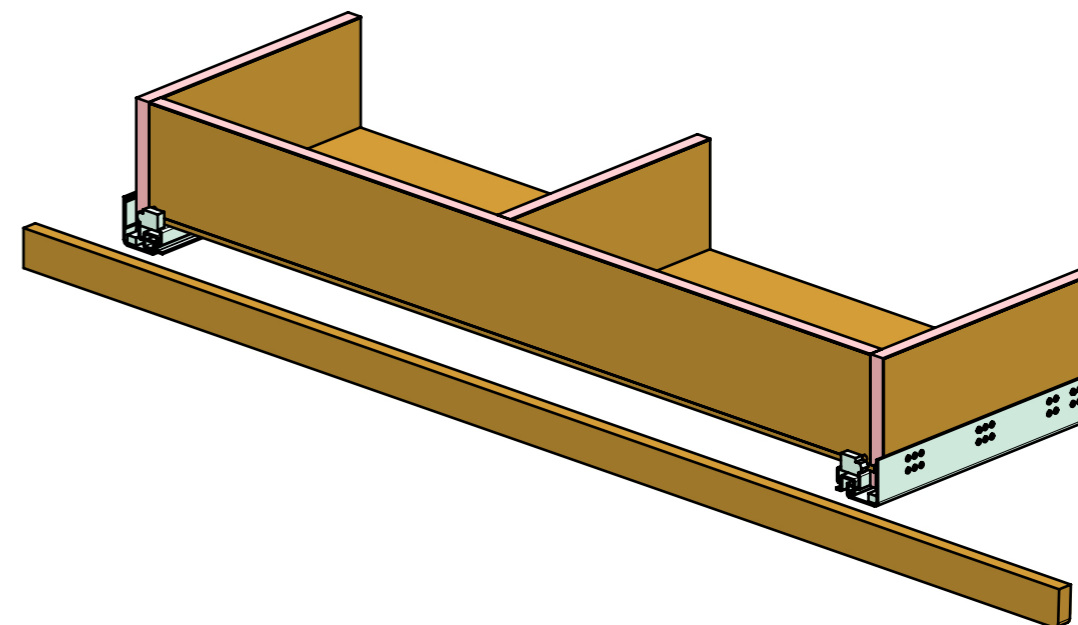
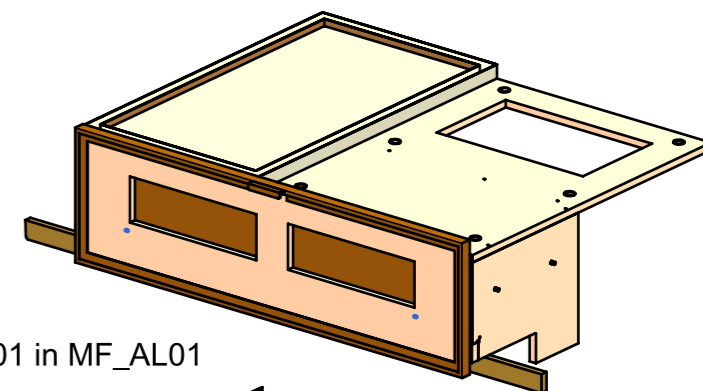

FERRAMENTA	QTY
CP GUIDA TANDEMPUS 300_HAFELE_423_54_730_ESSEPI_00175852	1

LOCALE	CODICE	DESCRIZIONE COMPONENTE	FINITURA	GR
CABINA ARMATORE	MD298_AP01	COMODINO LATO DIVANO_Var.1	LAMINATO LG23 PORO ROVERE	8

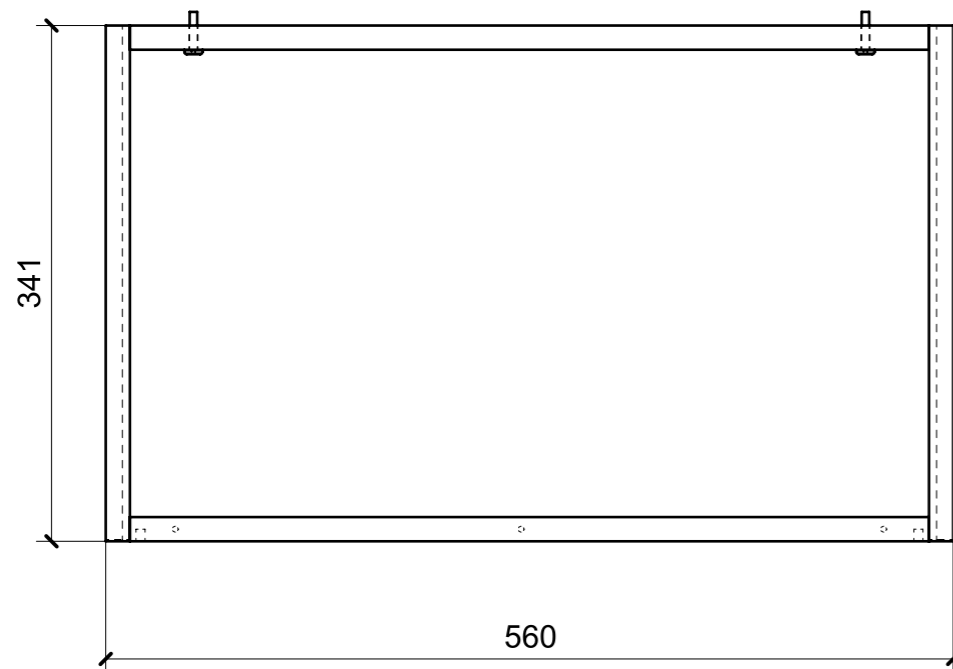
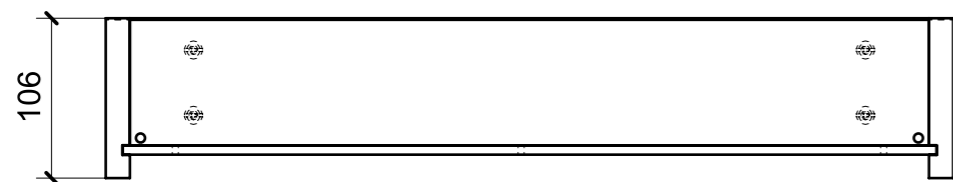

ELEMENTI DA MONTARE
 con R01_AP01_01-->06; AP01_01 in MF_AP01
 e spedire con unico imballo

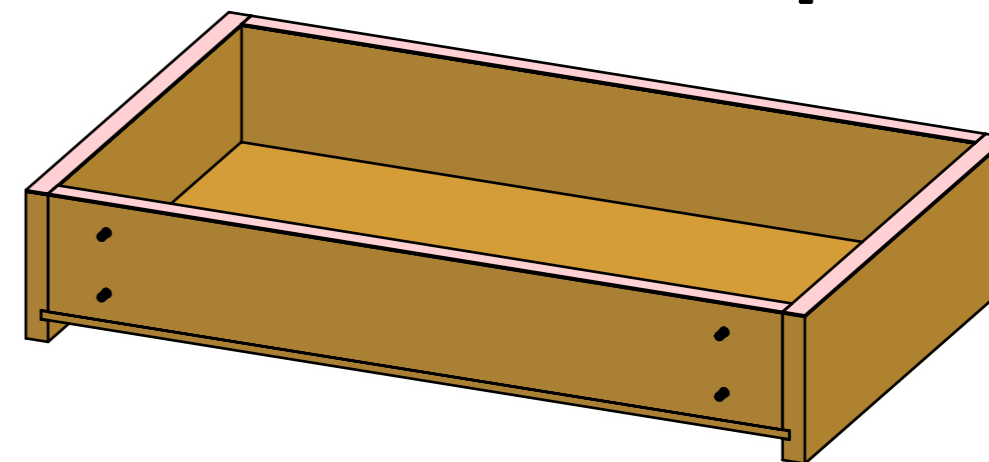
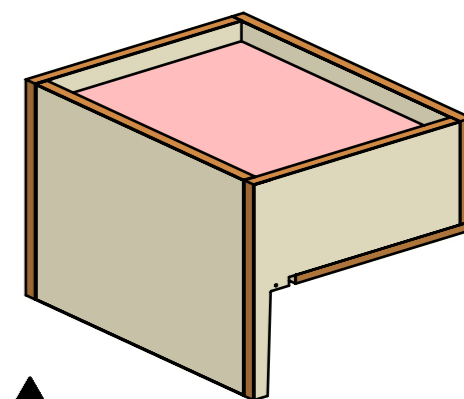

FERRAMENTA	QTY
VITE 5MA X 25 TESTA BOMBATA	4

LOCALE	CODICE	DESCRIZIONE COMPONENTE	FINITURA	Q.TA
CABINA ARMATORE	MD298_AQ01	CIELINO MURATA DX	OKUME' GREZZO	1

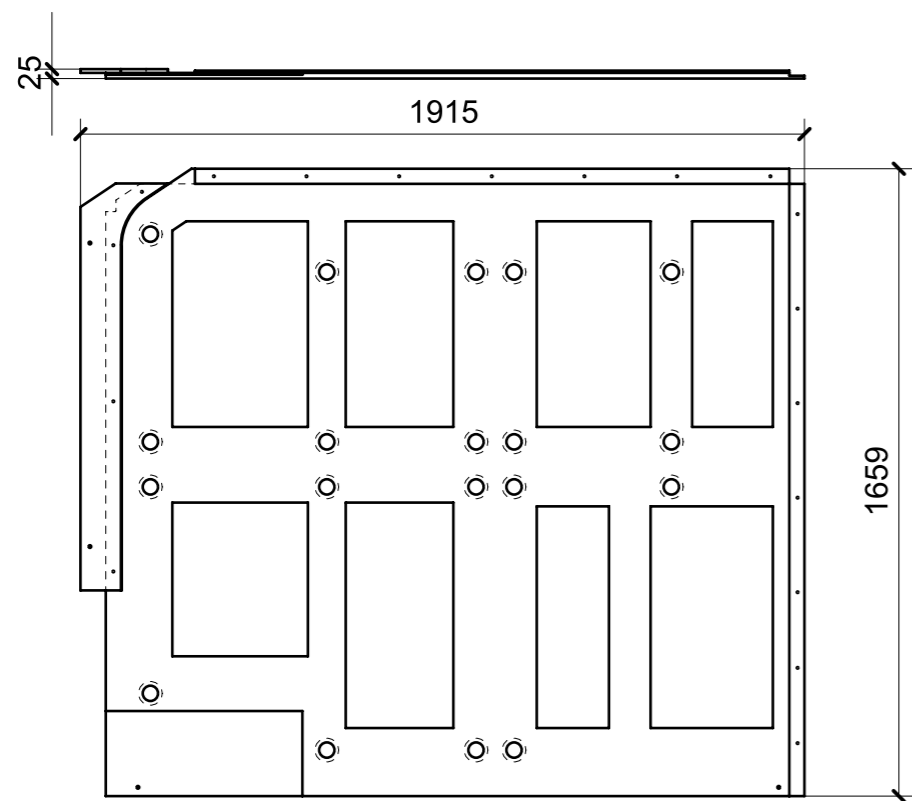

01

FERRAMENTA	QTY
VITE 6MA X 20 TESTA BOMBATA	1
VITE 6MA X 25 TESTA BOMBATA	1
FITLOCK F_MASCHERPA_6020101102	19

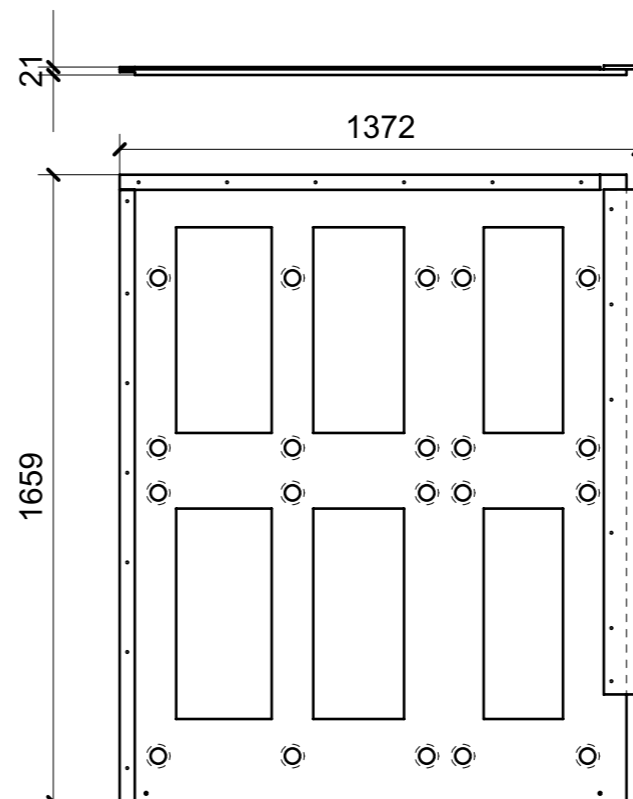

02

FERRAMENTA	QTY
VITE 6MA X 25 TESTA BOMBATA	2
FITLOCK F_MASCHERPA_6020101102	20

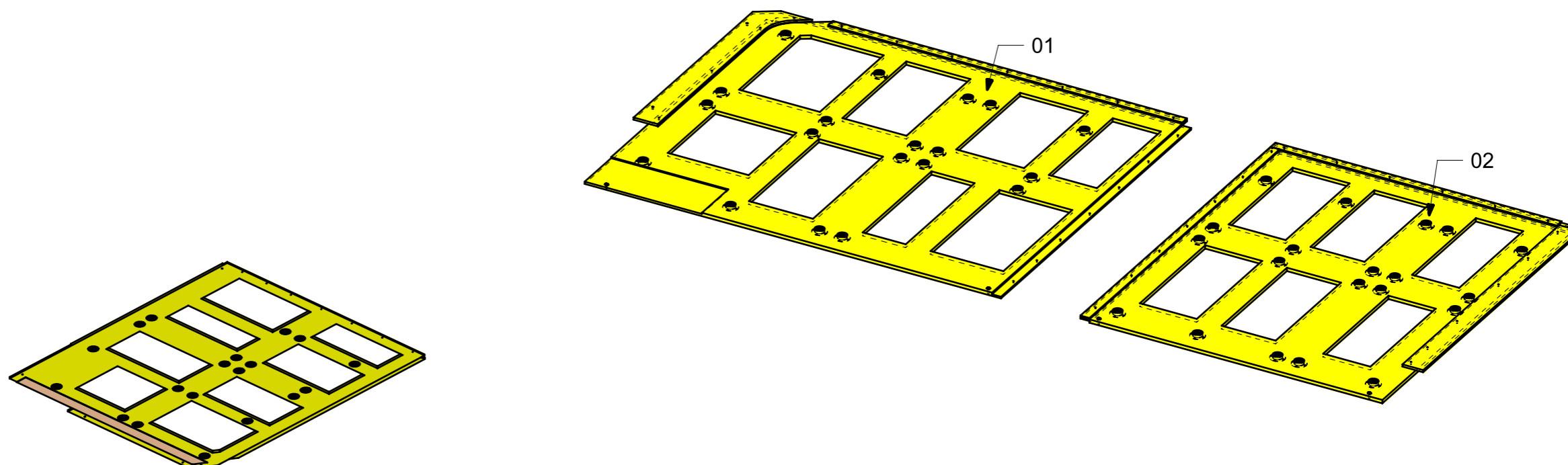

LOCALE	CODICE	DESCRIZIONE COMPONENTE	FINITURA	Q.TA
CABINA ARMATORE	MD298_AS01	CIELINO MURATA SX	OKUME' GREZZO	1

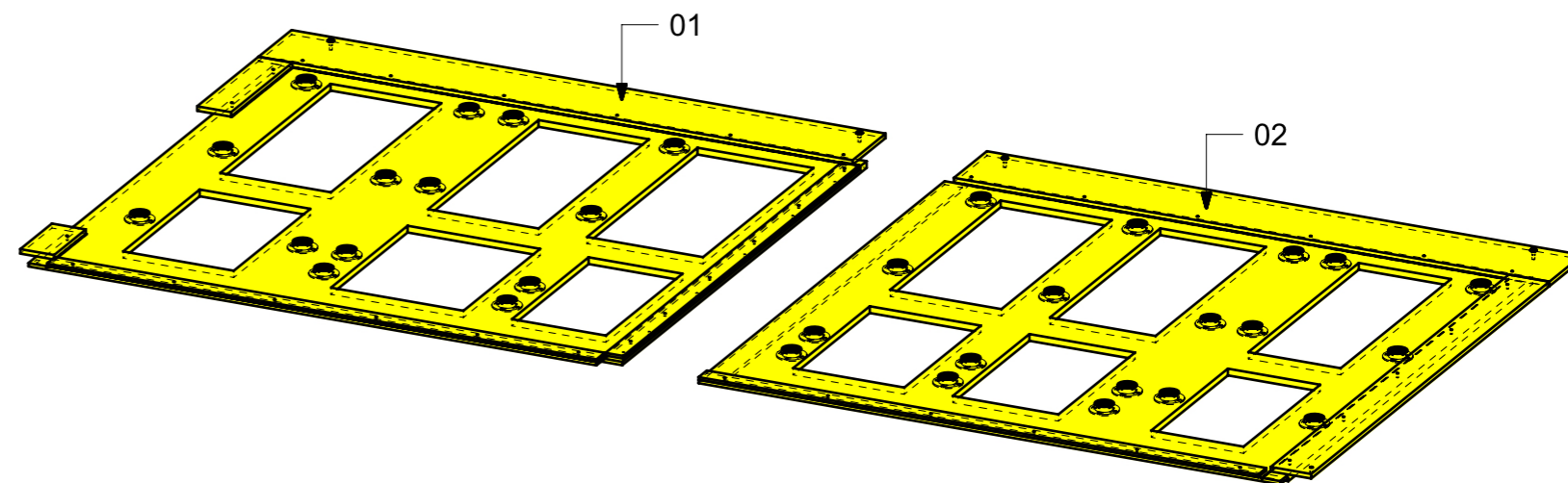
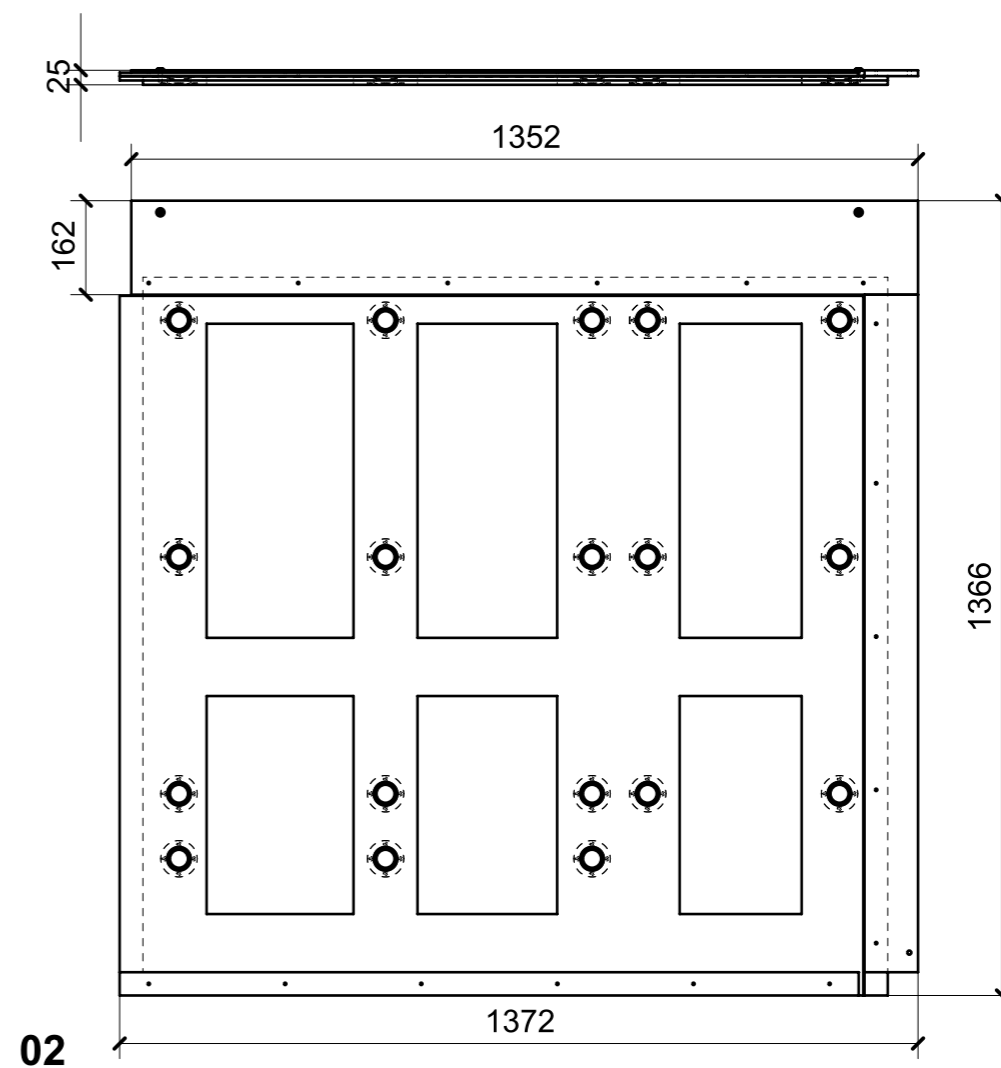
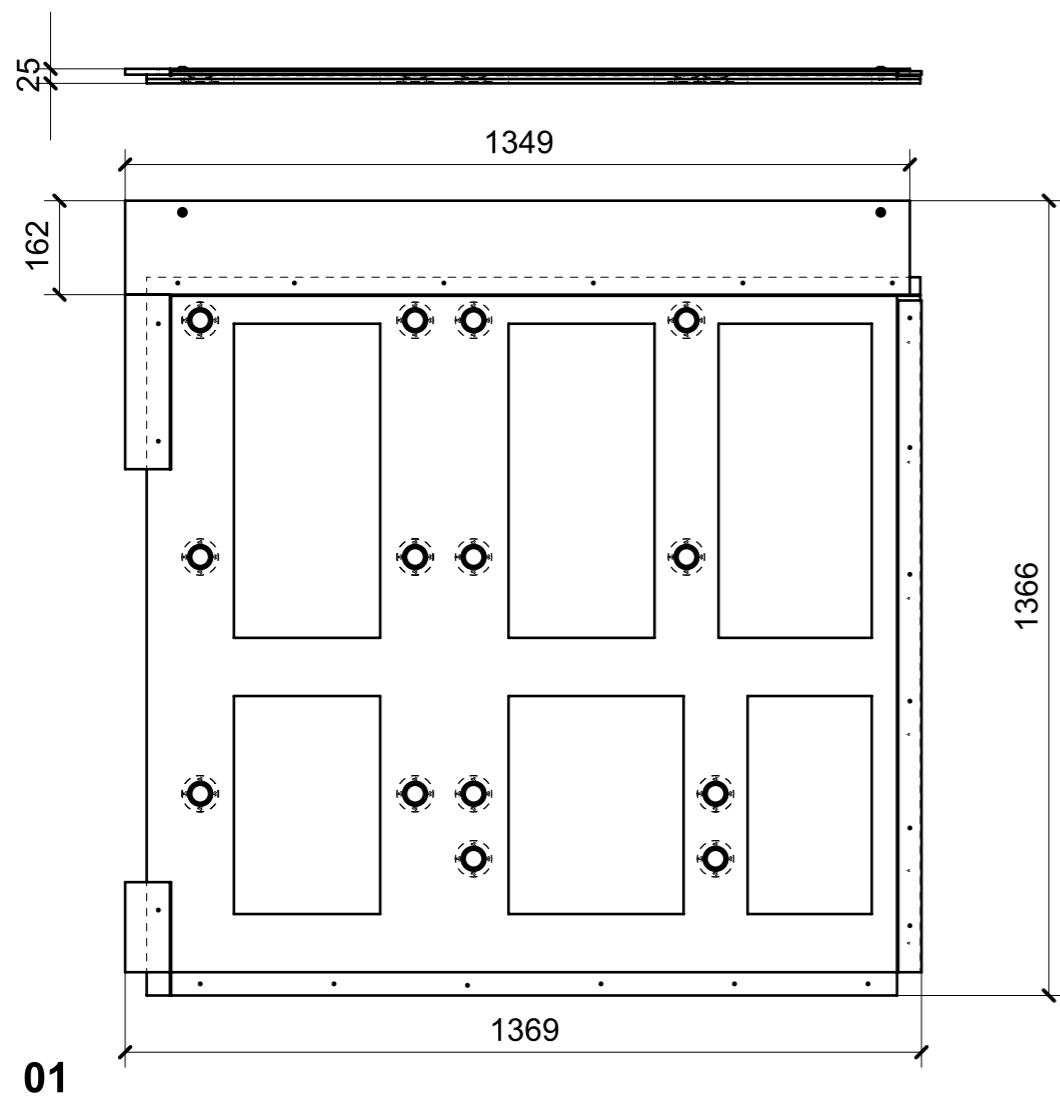

FERRAMENTA	QTY
VITE 6MA X 20 TESTA BOMBATA	4
FITLOCK F_MASCHERPA_6020101102	32

LOCALE	CODICE	DESCRIZIONE COMPONENTE	FINITURA	GR.
CABINA ARMATORE	MD298_AW01	CASSETTIERA Var.3	LAMINATO LG23 PORO ROVERE	GR8

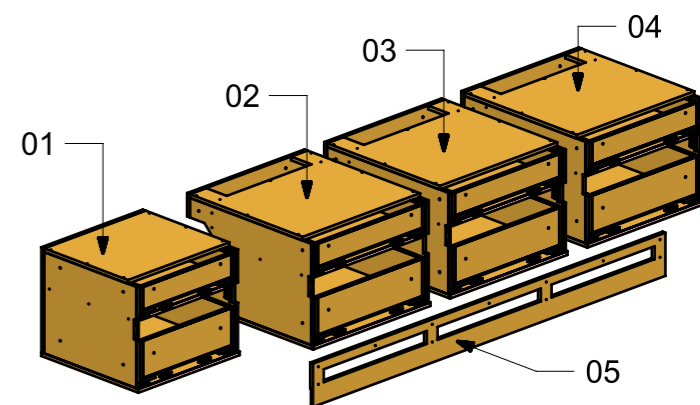
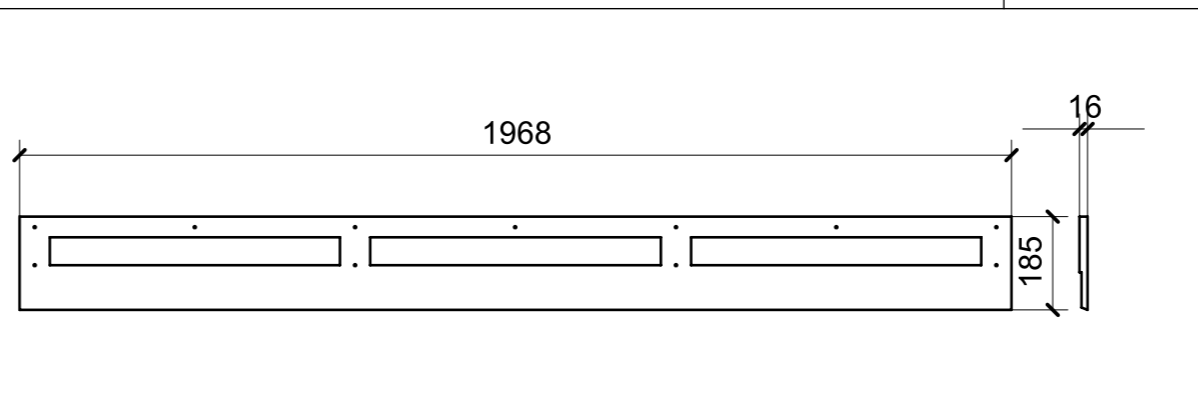
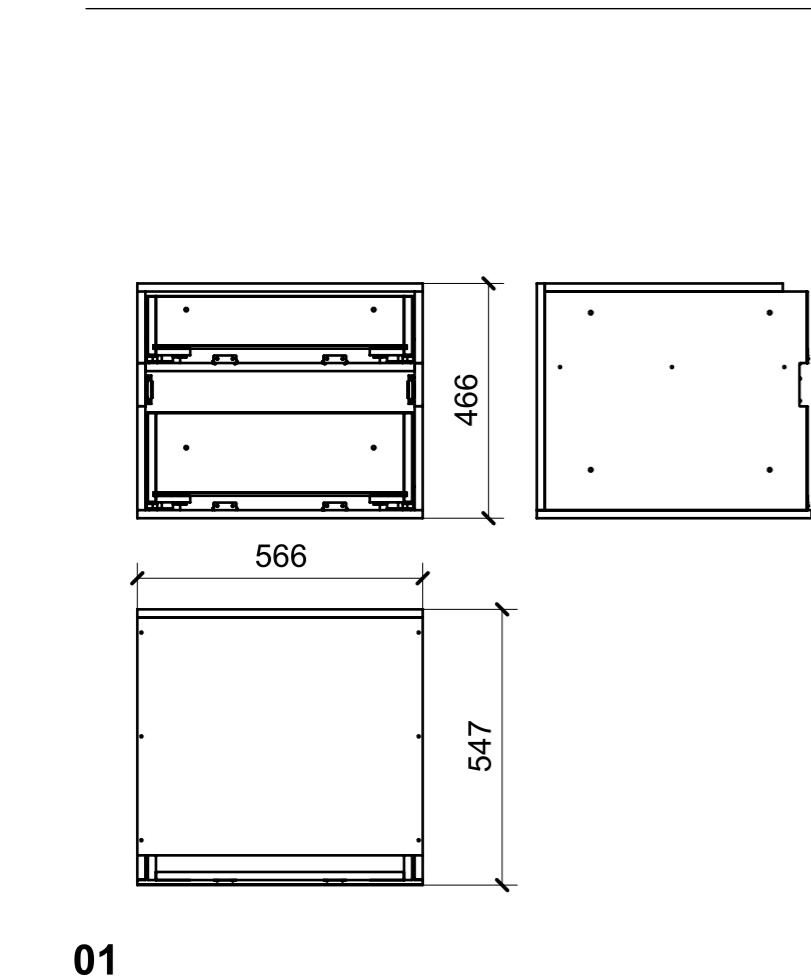
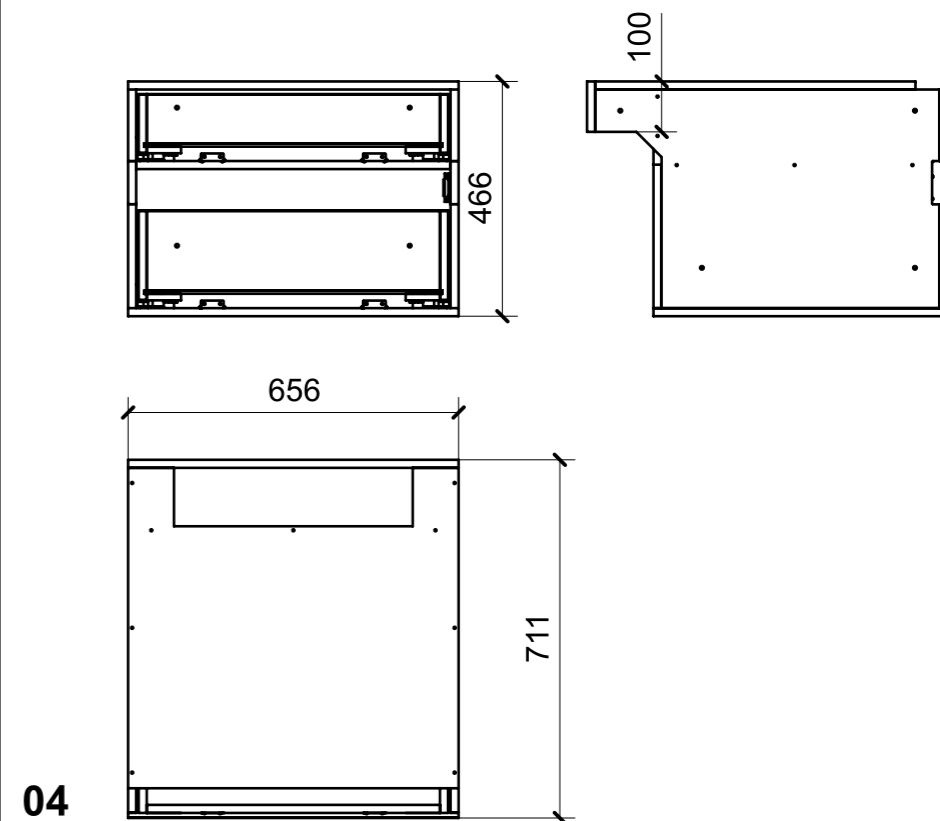
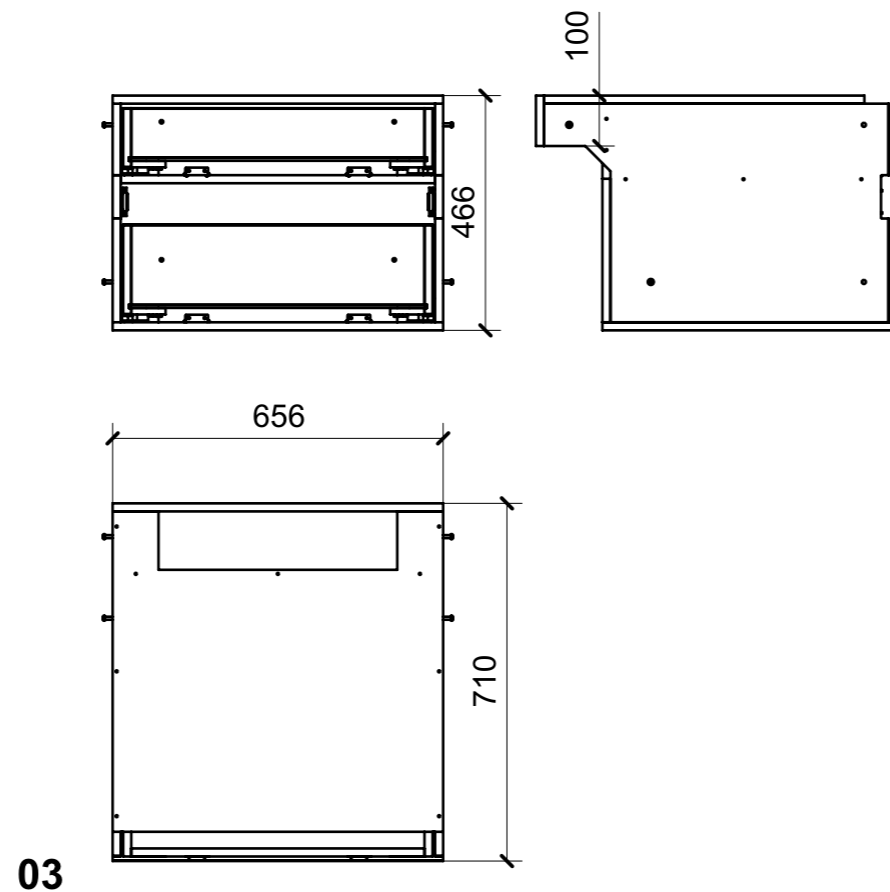
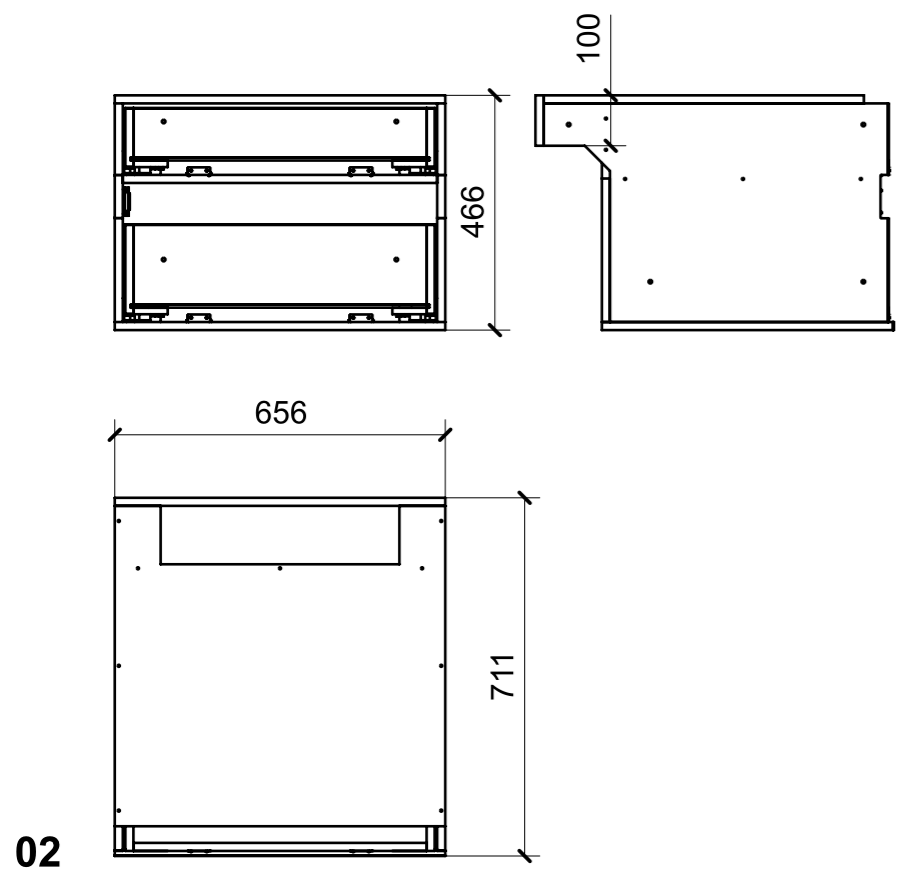

FERRAMENTA	QTY
BUSSOLA 6MA X 10 FORO DIAM.8	4
VITE 6MA X 25 TESTA BOMBATA NERA BHCS 10.9 ISO 7380	4
CHIUSURA A SPINTA_TECHNOPARTNER_SOU C3-203	6
GUIDA DYNAPRO SOFTCLOSE L500 L_FBC_F130107820 4D	8
GUIDA DYNAPRO FRONT LOCKING DEVICE R_FBC_F134108955 4D	8
CALAMITA SEALED MAGNETIC_TECNOPARTNER_MC-JM50-BL	16
PLACCHETTA COUNTER STEEL_TECNOPARTNER_MC-JM49	16
GUIDA DYNAPRO SOFTCLOSE L500 R_FBC_F130107820 4D	8
GUIDA DYNAPRO FRONT LOCKING DEVICE L_FBC_F134108955 4D	8
GUIDA DYNAPRO ADJUSTMENT ADAPTER R_FBC_F134141746 4D	8
GUIDA DYNAPRO ADJUSTMENT ADAPTER L_FBC_F134141746 4D	8

LOCALE	CODICE	DESCRIZIONE COMPONENTE	FINITURA	GR.
CABINA ARMATORE	MD298_AU01	VANITY CASSETTIERA Var.2	LAMINATO LG23 PORO ROVERE	08

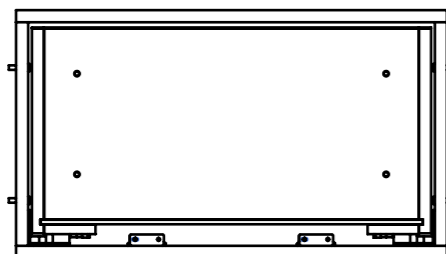

01

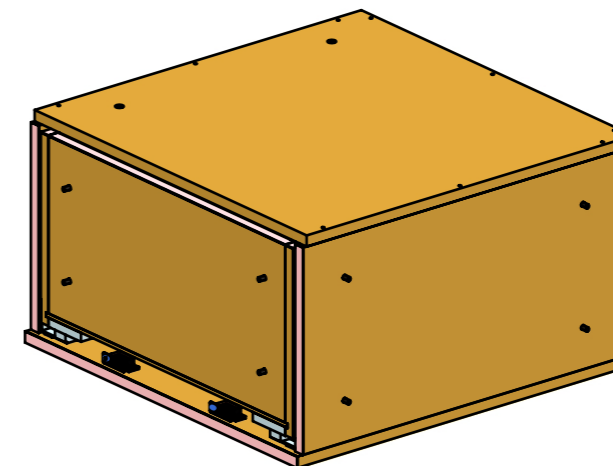
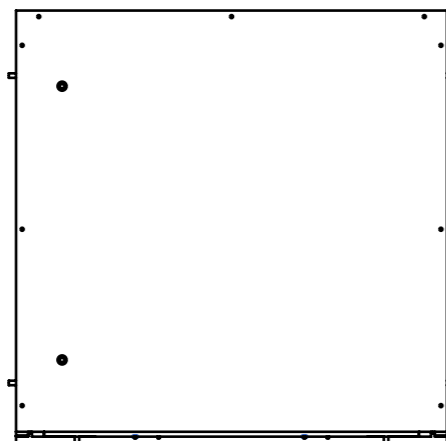
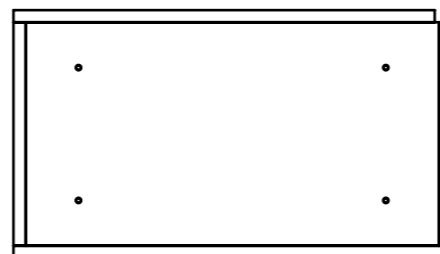

FERRAMENTA	QTY
GUIDA DYNAPRO ADJUSTAMENT ADAPTER L_FBC_F134141746 4D	1
GUIDA DYNAPRO FRONT LOCKING DEVICE L_FBC_F134108955 4D	1
GUIDA DYNAPRO SOFTCLOSE L500 L_FBC_F130107820 4D	1
GUIDA DYNAPRO FRONT LOCKING DEVICE R_FBC_F134108955 4D	1
GUIDA DYNAPRO ADJUSTAMENT ADAPTER R_FBC_F134141746 4D	1
GUIDA DYNAPRO SOFTCLOSE L500 R_FBC_F130107820 4D	1
CALAMITA SEALED MAGNETIC_TECNOPARTNER_MC-JM50-BL	2
PLACCHETTA COUNTER STEEL_TECNOPARTNER_MC-JM49	2
BUSSOLA 6MA X 10 FORO DIAM.8	2
VITE 6MA X 25 TESTA BOMBATA NERA BHCS 10.9 ISO 7380	12

LOCALE	CODICE	DESCRIZIONE COMPONENTE	FINITURA	GR.
CABINA ARMATORE	MD298_AX01	VANITY CASSETTIERA PRUA Var.2	LAMINATO LG23 PORO ROVERE	8

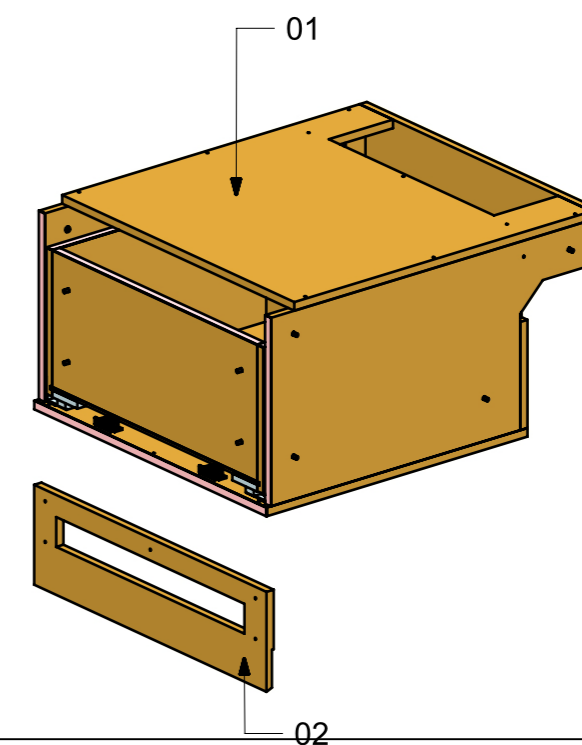
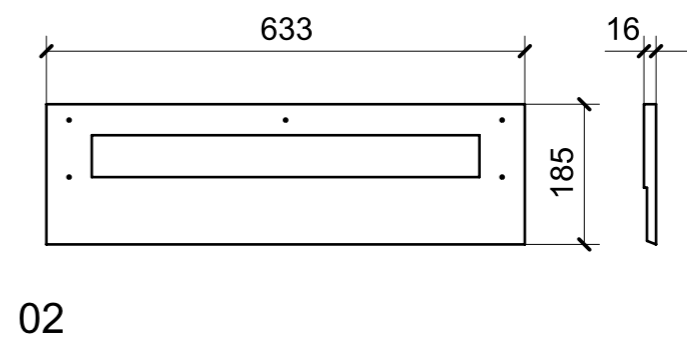
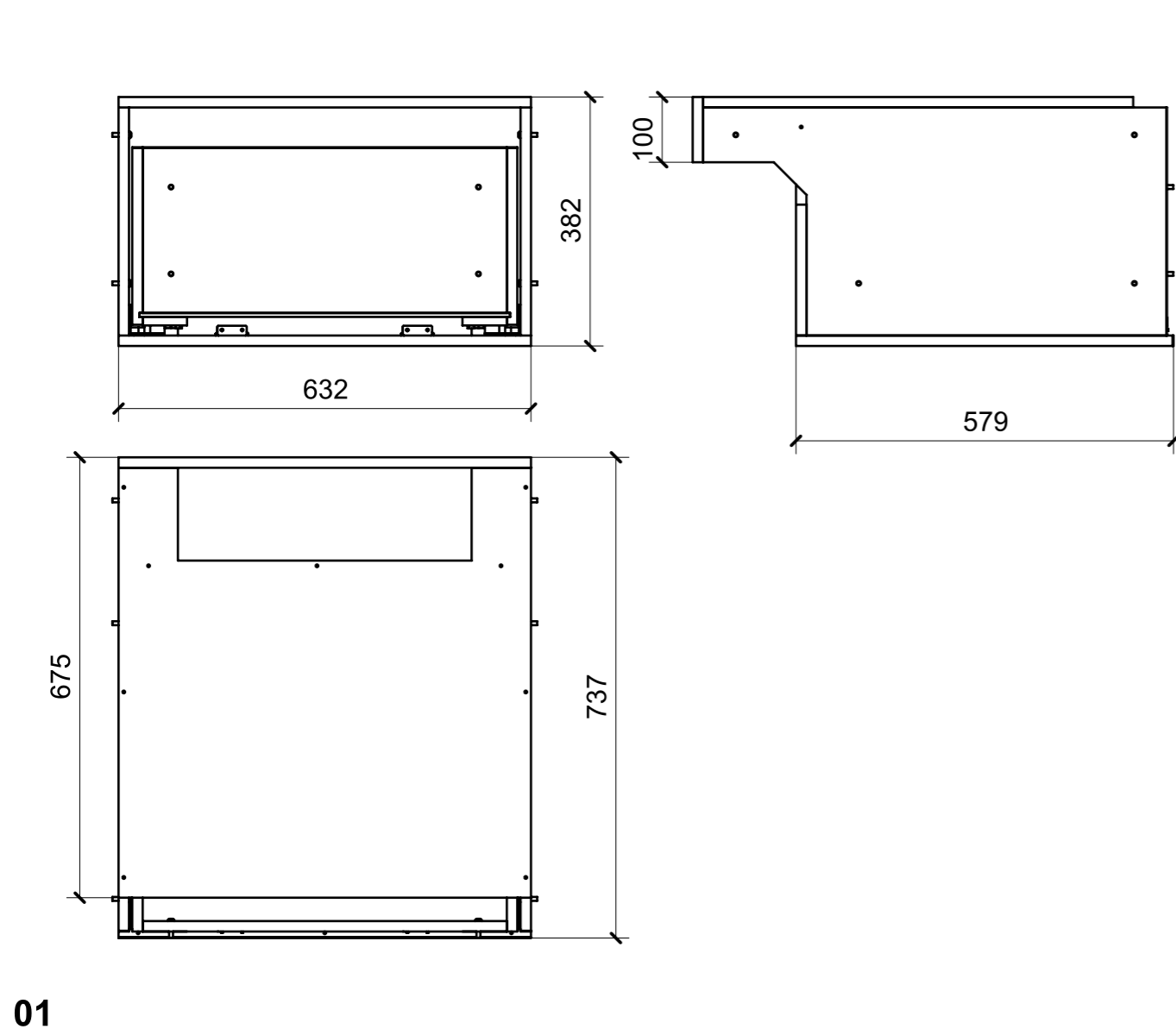

FERRAMENTA	QTY
GUIDA DYNAPRO FRONT LOCKING DEVICE R_FBC_F134108955 4D	1
GUIDA DYNAPRO ADJUSTMENT ADAPTER R_FBC_F134141746 4D	1
GUIDA DYNAPRO SOFTCLOSE L500 R_FBC_F130107820 4D	1
CALAMITA SEALED MAGNETIC_TECNOPARTNER_MC-JM50-BL	2
PLACCHETTA COUNTER STEEL_TECNOPARTNER_MC-JM49	2
GUIDA DYNAPRO ADJUSTMENT ADAPTER L_FBC_F134141746 4D	1
GUIDA DYNAPRO FRONT LOCKING DEVICE L_FBC_F134108955 4D	1
GUIDA DYNAPRO SOFTCLOSE L500 L_FBC_F130107820 4D	1
VITE 6MA X 25 TESTA BOMBATA NERA BHCS 10.9 ISO 7380	12