

AZ26M

REV. 01-2023

REV. GR 9

LOCALE	CODICE	DESCRIZIONE COMPONENTE	FINITURA	Q.TA	OPERATORE
CUCINA	AZ26M-P01_KD01	PENSILE CUCINA POPPA	FAGGIO	1	Damiano

1 - L 495 x H294 x sp 19

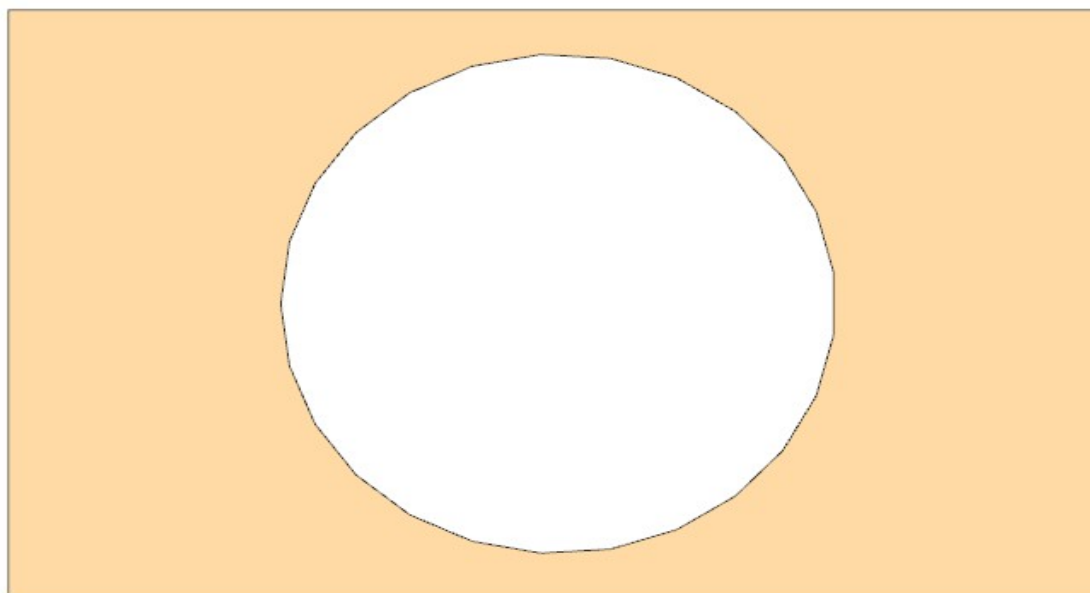

AZ26M

REV. 01-2023

REV. GR 9

LOCALE	CODICE	DESCRIZIONE COMPONENTE	FINITURA	Q.TA	OPERATORE
CUCINA	AZ26M-P01_KF01	BASE CUCINA PRUA	FAGGIO\ GOMMA	2	Damiano

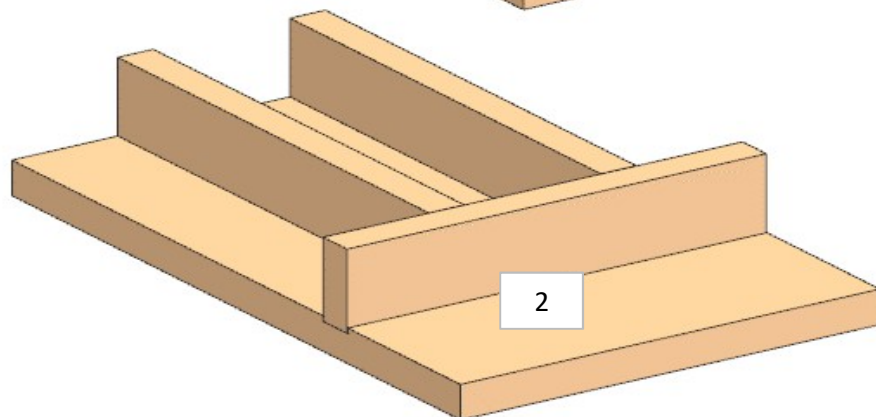
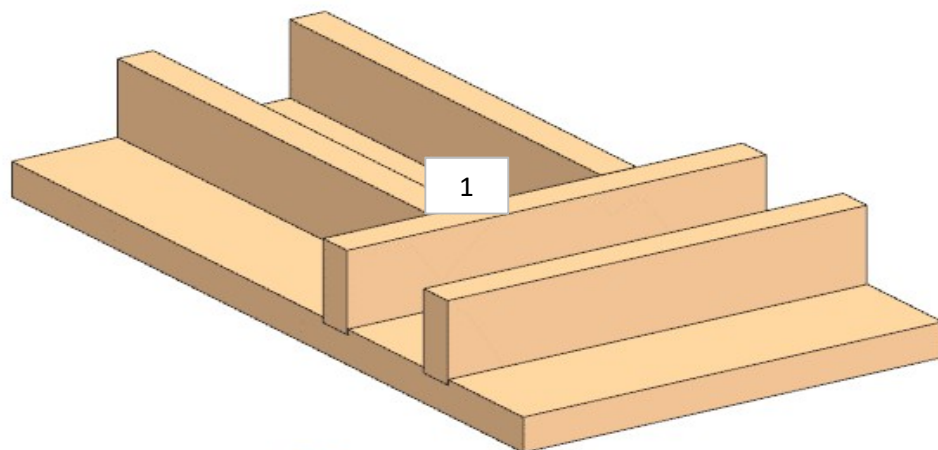

1 - L 407 x H 255 x sp 19
2 - L 357 x H 255 x sp 19

AZ26M

REV.2025

LOCALE	CODICE	DESCRIZIONE COMPONENTE	FINITURA	Q.TA	OPERATORE
CUCINA	AZ26M-P01_KKF01	FORNO 90 Var 2	FAGGIO\GOMMA	3	Damiano

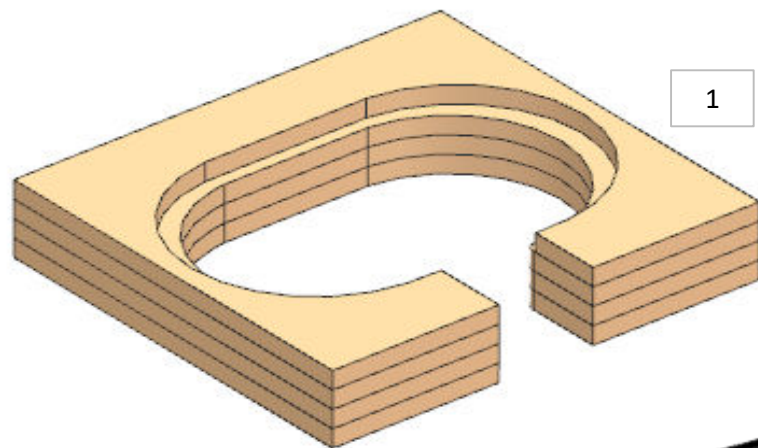

1

- 1 - L 375 x H 408 x sp 76
- 2 - L 240 x H 374 x sp 4
- 3 - L 375 x H 408 x sp 4



2



3

AZ26M

REV.2025

LOCALE	CODICE	DESCRIZIONE COMPONENTE	FINITURA	Q.TA	OPERATORE
CUCINA	AZ26M-P01_KKK01	FORNO 60 Var 1	FAGGIO\ GOMMA	4	Damiano

- 1 L 297 x H 472 x sp 76
- 2 L 240 x H 365 x 4
- 3 L 218 x H 403 x sp 4
- 4 L 297 x H 472 x sp 4

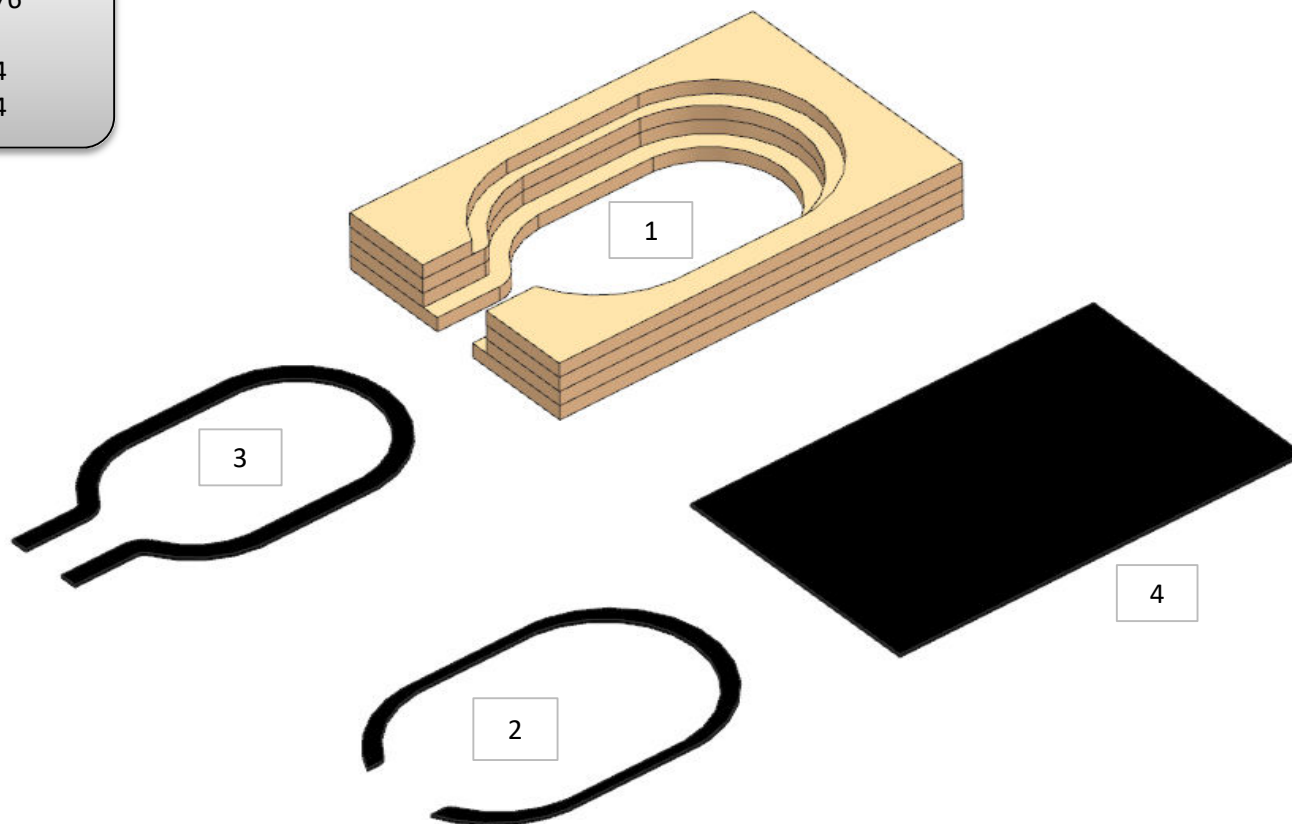

AZ26M

REV. 01-2023

REV. GR 9

LOCALE	CODICE	DESCRIZIONE COMPONENTE	FINITURA	Q.TA	OPERATORE
CUCINA	AZ26M-P01_KL01	MOBILE PORTABICCHIERI	FAGGIO\GOMMA	8	Damiano

