

LOCALE	CODICE	DESCRIZIONE COMPONENTE	FINITURA	Q.TA
LOBBY	MD299_R01_CA01	CIELINO CORRIDOIO	LASTRA SCURA	1

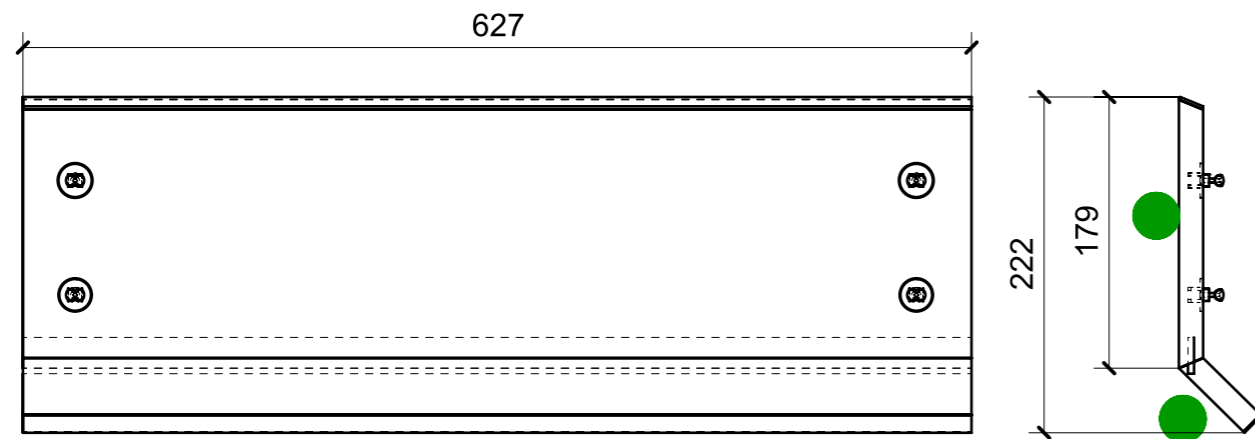

01

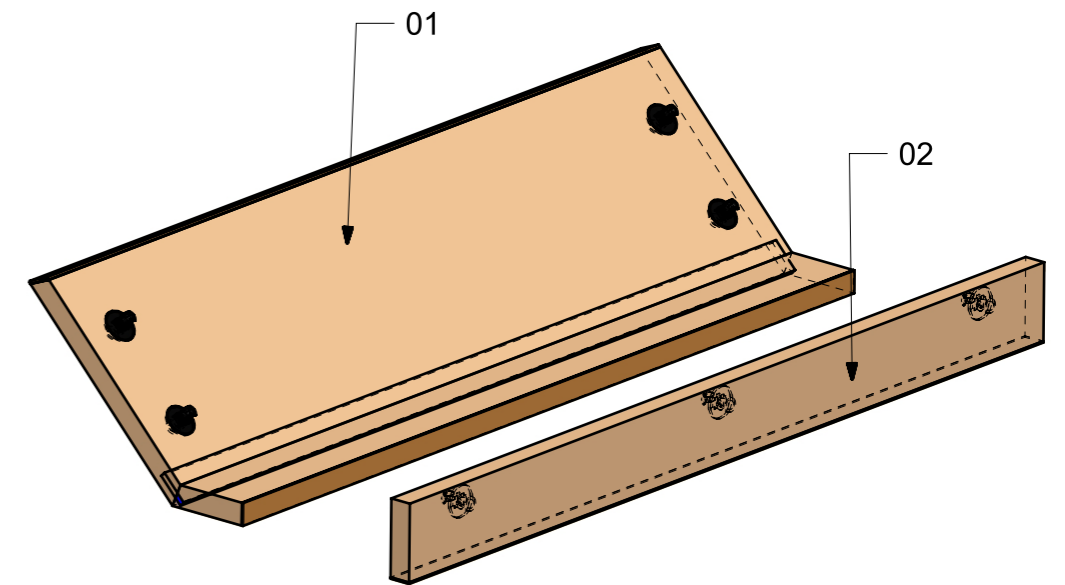

FERRAMENTA	QTY
MS INCASSO_ITALVIPLA_972_FMPC_M1B	7

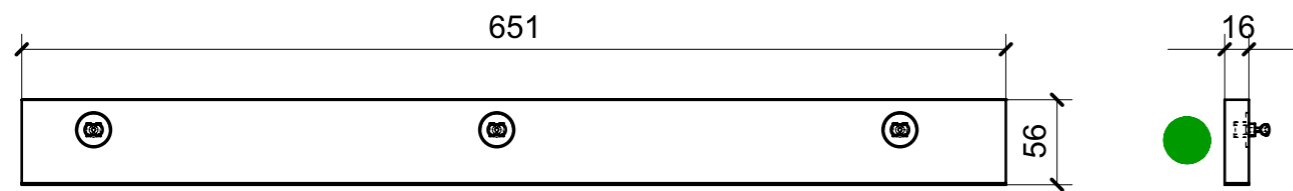

02

VERNICIATURA LASTRA/LACCATI:

● = VERNICIARE 1 LATO + FILI RASATI O BORDATI

NESSUN SIMBOLO = VERNICIARE 2 LATI + FILI RASATI O BORDATI

LOCALE	CODICE	DESCRIZIONE COMPONENTE	FINITURA	Q.TA
LOBBY	MD299_L01_CA01	CIELINO CORRIDOIO	LACCATO BIANCO 9010	1

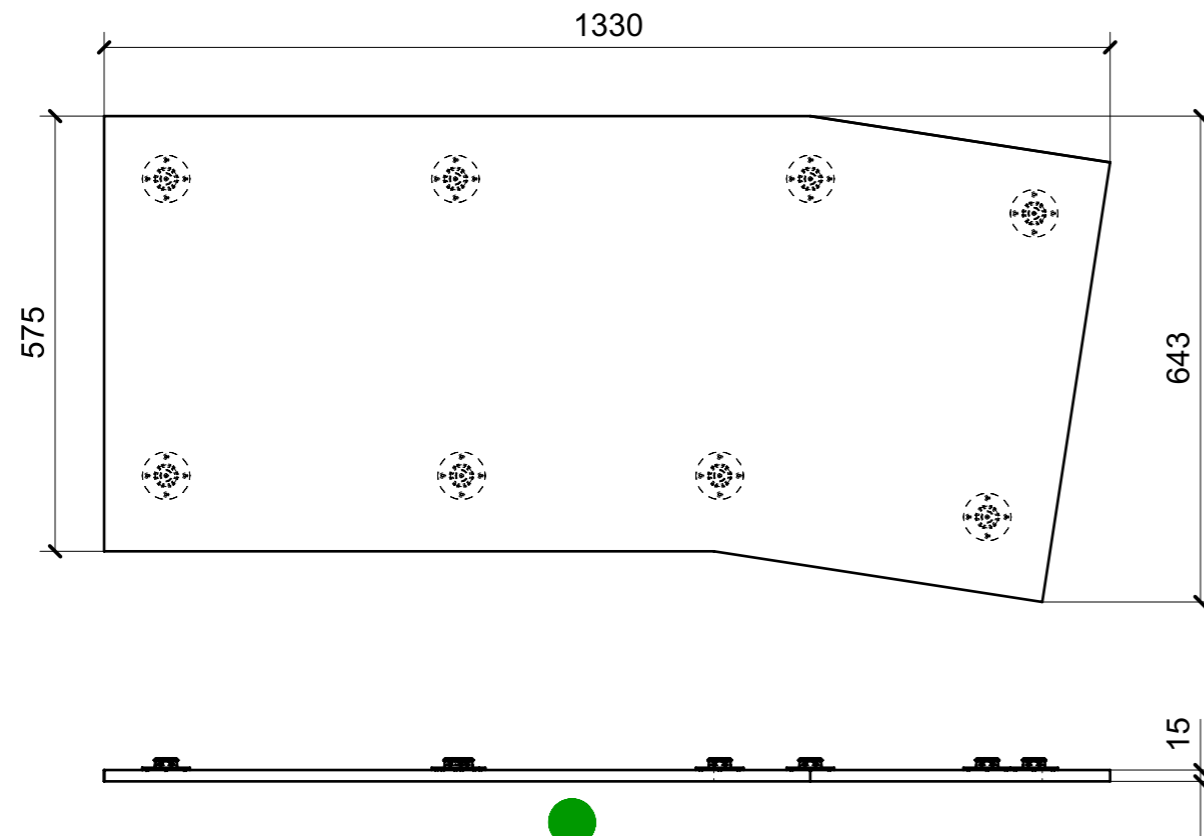

01

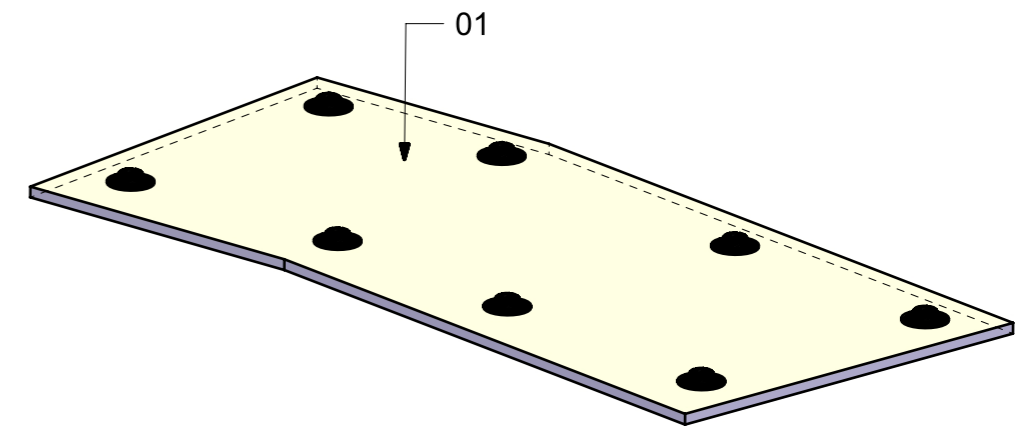

FERRAMENTA	QTY
FITLOCK M_MASCHERPA_3MM_6020202101	8

VERNICIATURA LASTRA/LACCATI:

● = VERNICIARE 1 LATO + FILI RASATI O BORDATI

NESSUN SIMBOLO = VERNICIARE 2 LATI + FILI RASATI O BORDATI

LOCALE	CODICE	DESCRIZIONE COMPONENTE	FINITURA	Q.TA
LOBBY	MD299_R01_CB01	CIELINO GRIGLIA A.C.	LAISTRA SCURA	1

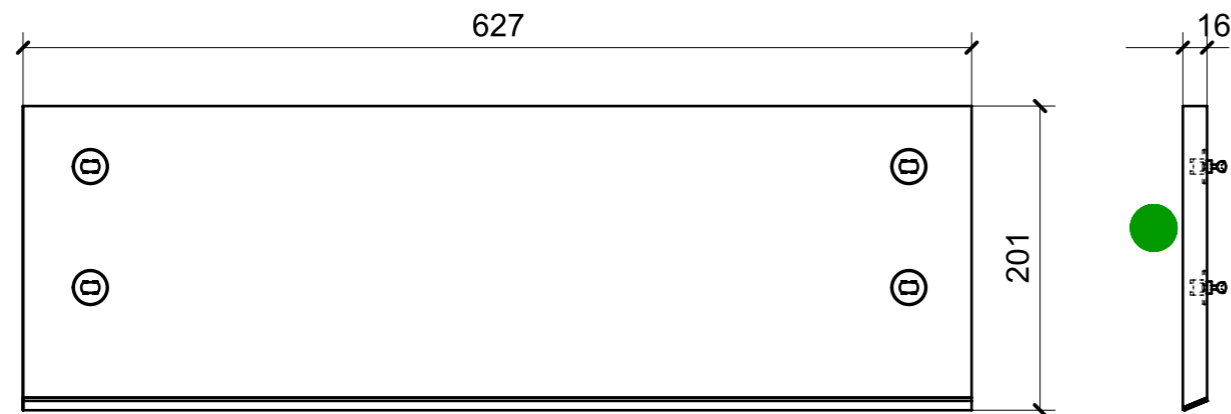

01

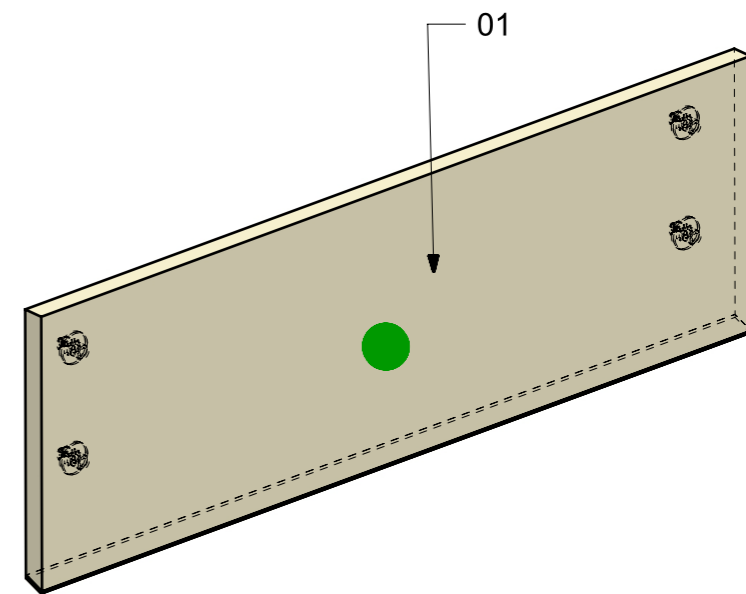

FERRAMENTA	QTY
MS INCASSO_ITALVIPLA_972_FMPC_M1B	4

VERNICIATURA LASTRA/LACCATI:

● = VERNICIARE 1 LATO + FILI RASATI O BORDATI

NESSUN SIMBOLO = VERNICIARE 2 LATI + FILI RASATI O BORDATI

LOCALE	CODICE	DESCRIZIONE COMPONENTE	FINITURA	Q.TA
LOBBY	MD299_L01_CB01	CIELINO GRIGLIA A.C.	LACCATO BIANCO 9010	1

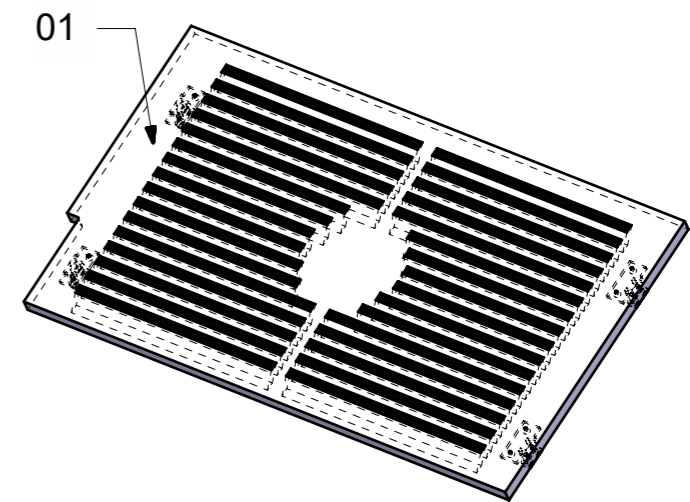
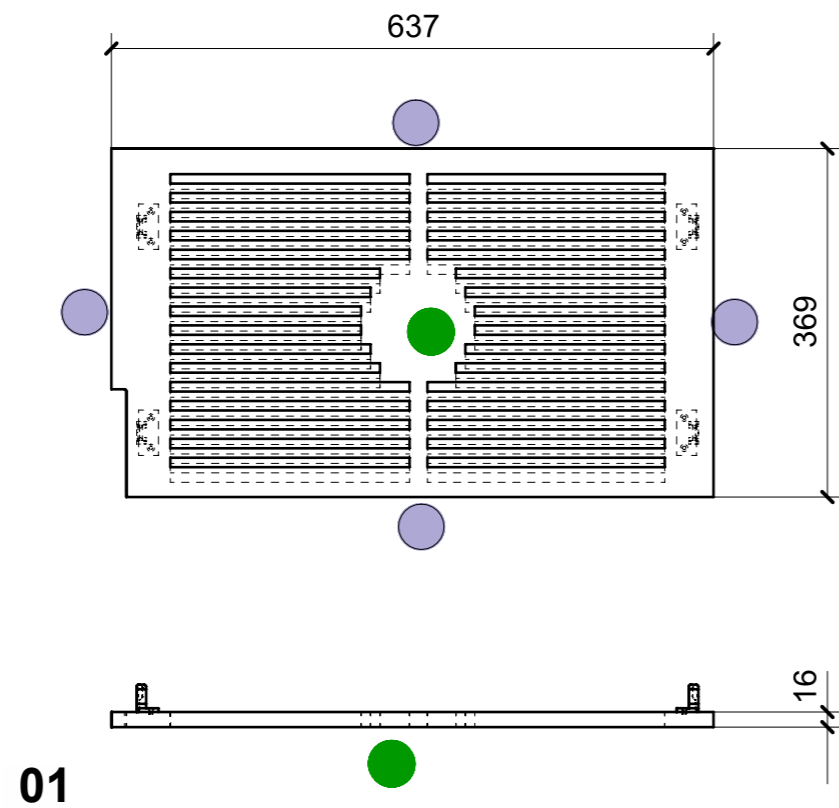

FERRAMENTA	QTY
KEKU ESTRAZIONE FRONTALE PARTE PANNELLO AS_HAFELE_262_50_359	4

VERNICIATURA LASTRA/LACCATI:

● = VERNICIARE 1 LATO + FILI RASATI O BORDATI

NESSUN SIMBOLO = VERNICIARE 2 LATI + FILI RASATI O BORDATI

LOCALE	CODICE	DESCRIZIONE COMPONENTE	FINITURA	Q.TA
LOBBY	MD299_MG_CC01	MURETTO SCALE	LASTRA SCURA	1

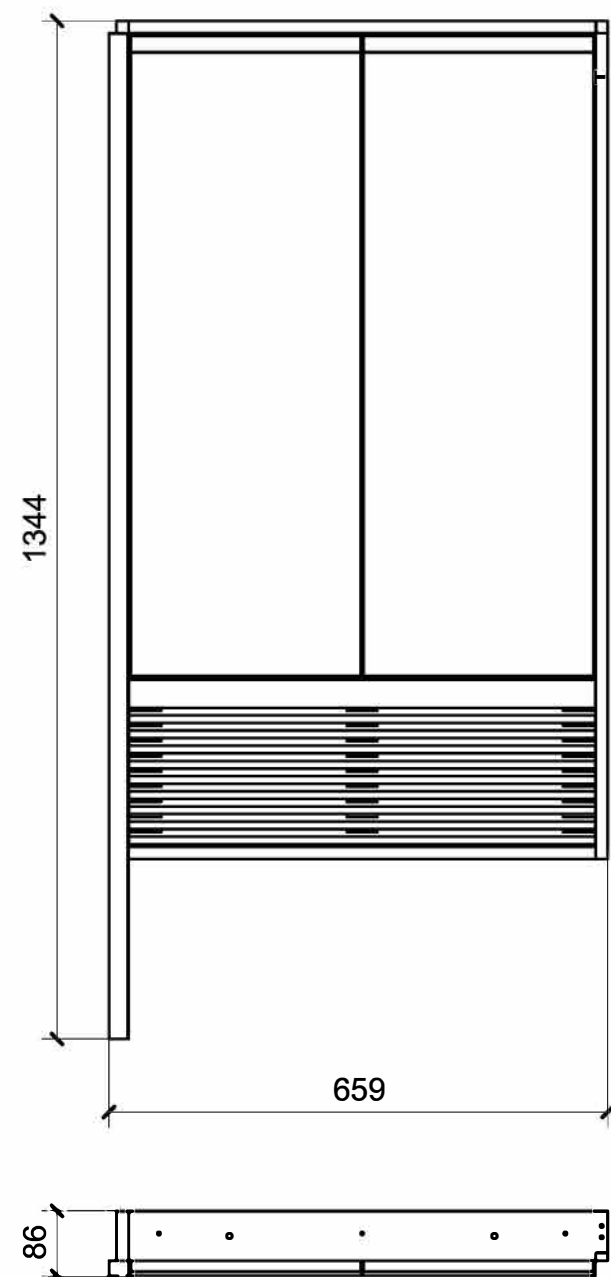

**MONTARE COME RAPPRESENTATO**

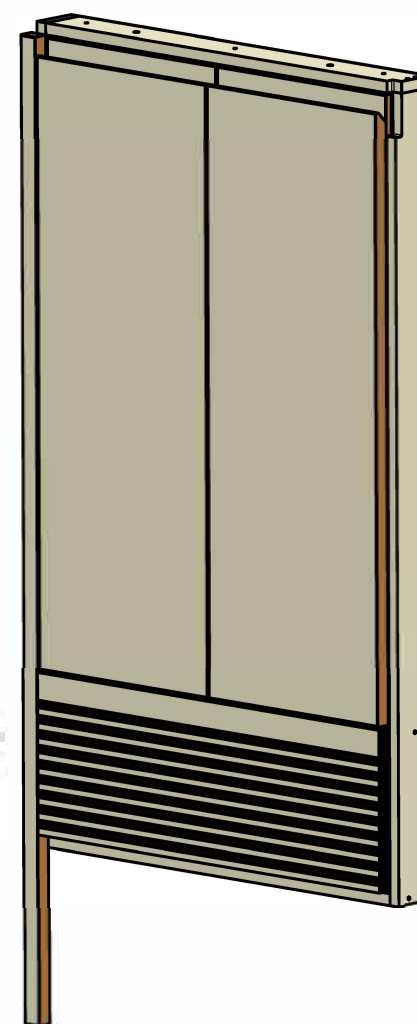

FERRAMENTA	QTY
BASE 6_HAFELE_329_84_026	4
BUSSOLA 5MA ANKOR BORGHI X CERNIERA COLLO PIENO	8
BUSSOLA 5MA ANKOR BORGHI X CERNIERA PIANA	8
CALAMITA SEALED MAGNETIC_TECNOPARTNER_MC-JM50-BL	2
CERNIERA 94° COLLO PIENO AMMORTIZZATA_HAFELE_329_49_313	4
GOMMINO PARACOLPO ANTA	2
KEKU ESTRAZIONE FRONTALE PARTE PANNELLO AS_HAFELE_262_50_359	4
KEKU ESTRAZIONE FRONTALE PARTE TELAIO AS_HAFELE_262_50_368	4
VITE 4MAX8 ANKOR BORGHI X CERNIERA COLLO PIENO	8
VITE 4MAX8 ANKOR BORGHI X CERNIERA PIANA	8

LOCALE	CODICE	DESCRIZIONE COMPONENTE	FINITURA	Q.TA
LOBBY	MD299_R01_CC01	MURETTO SCALE	LASTRA SCURA	1

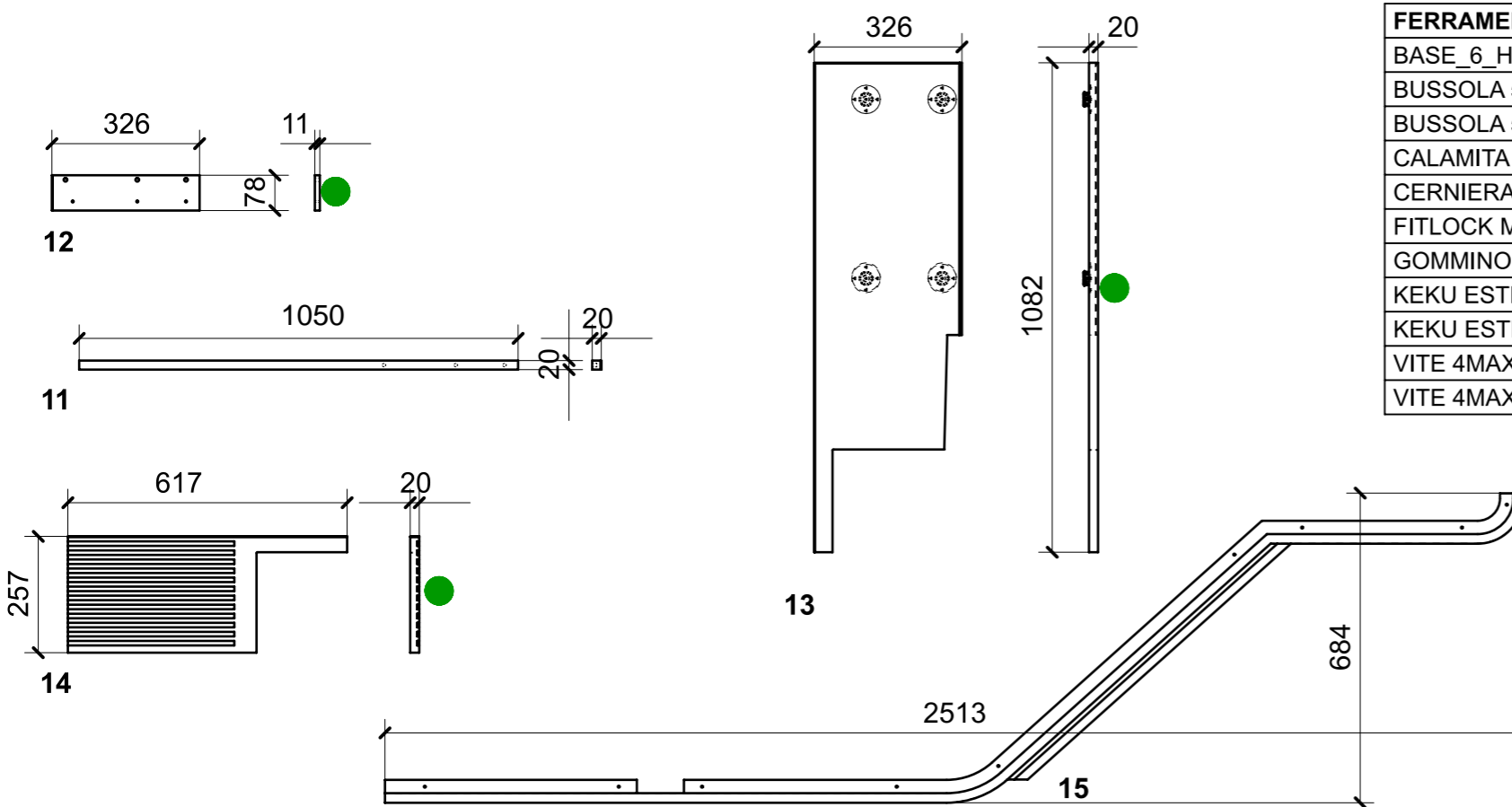
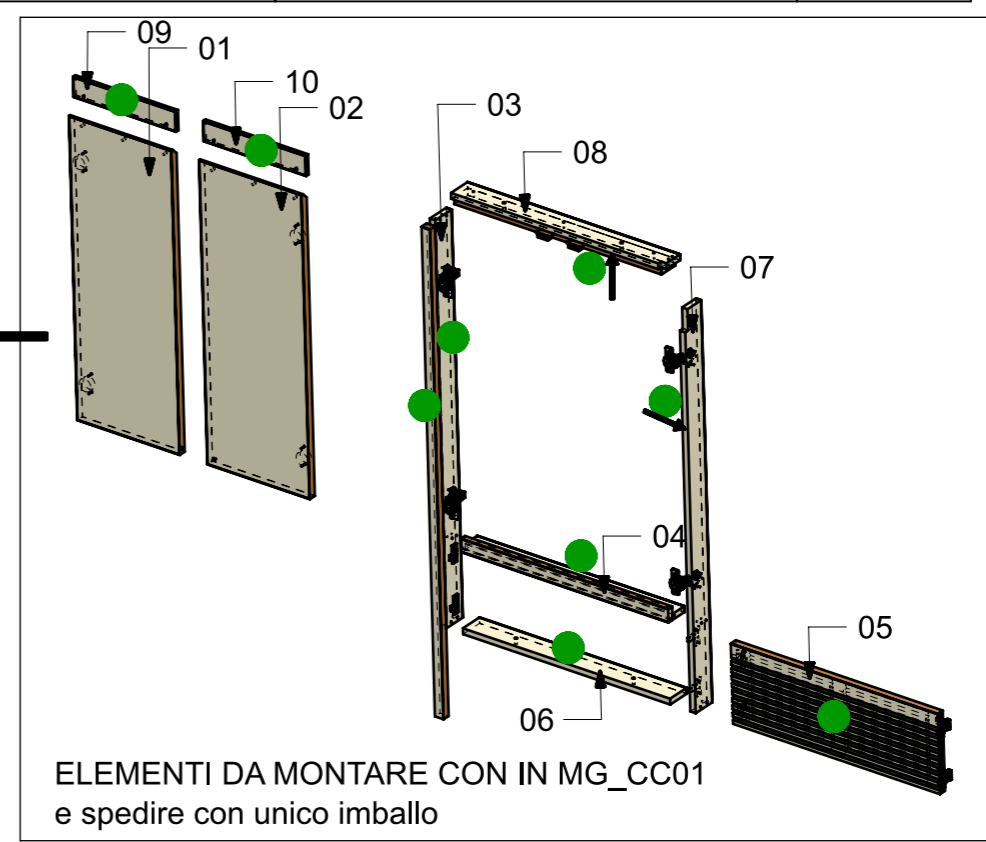
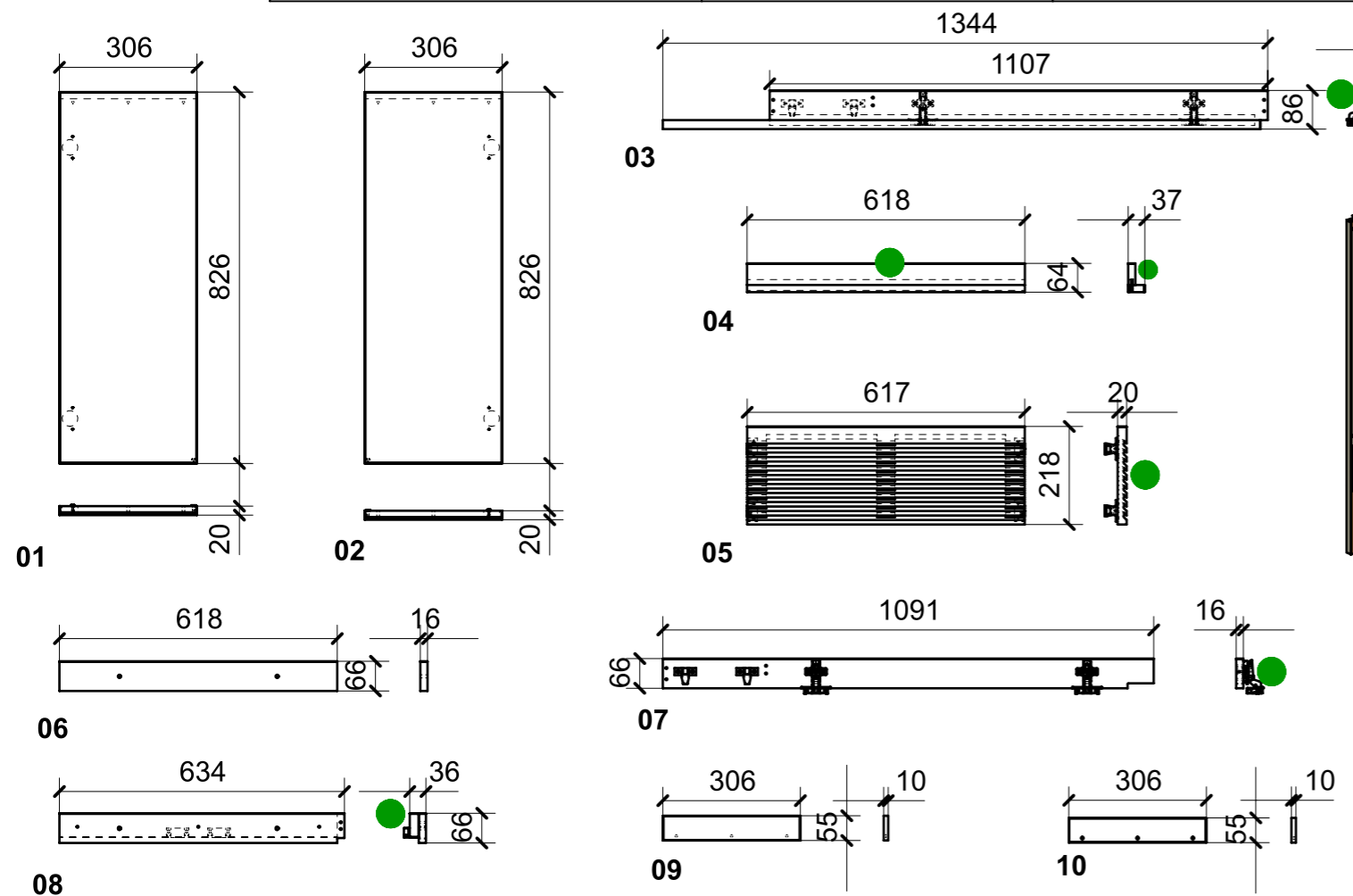

FERRAMENTA	QTY
BASE_6_HAFELE_329_84_026	4
BUSSOLA 5MA ANKOR BORGHI X CERNIERA COLLO PIENO	8
BUSSOLA 5MA ANKOR BORGHI X CERNIERA PIANA	8
CALAMITA SEALED MAGNETIC_TECNOPARTNER_MC-JM50-BL	2
CERNIERA 94°_COLLO PIENO AMMORTIZZATA_HAFELE_329_49_313	4
FITLOCK M_MASCHERPA_3MM_6020202101	4
GOMMINO PARACOLPO ANTA	2
KEKU ESTRAZIONE FRONTALE PARTE PANNELLO AS_HAFELE_262_50_359	4
KEKU ESTRAZIONE FRONTALE PARTE TELAIO AS_HAFELE_262_50_368	4
VITE 4MAX8 ANKOR BORGHI X CERNIERA COLLO PIENO	8
VITE 4MAX8 ANKOR BORGHI X CERNIERA PIANA	8

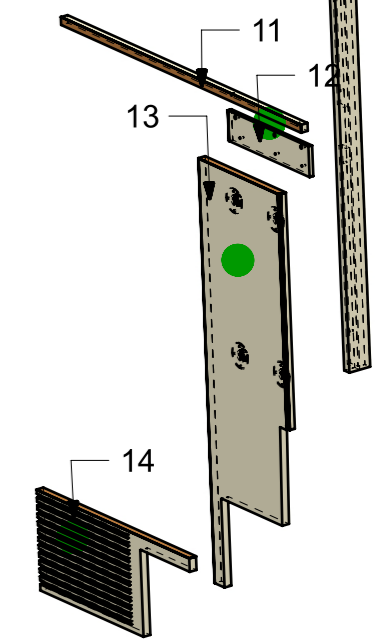

VERNICIATURA LASTRA/LACCATI:  
 ● = VERNICIARE 1 LATO + FILI RASATI O BORDATI  
 NESSUN SIMBOLO = VERNICIARE 2 LATI + FILI RASATI O BORDATI

LOCALE	CODICE	DESCRIZIONE COMPONENTE	FINITURA	Q.TA
LOBBY	MD299_R01_CF01	RIV SCALE SX	LASTRA SCURA	1

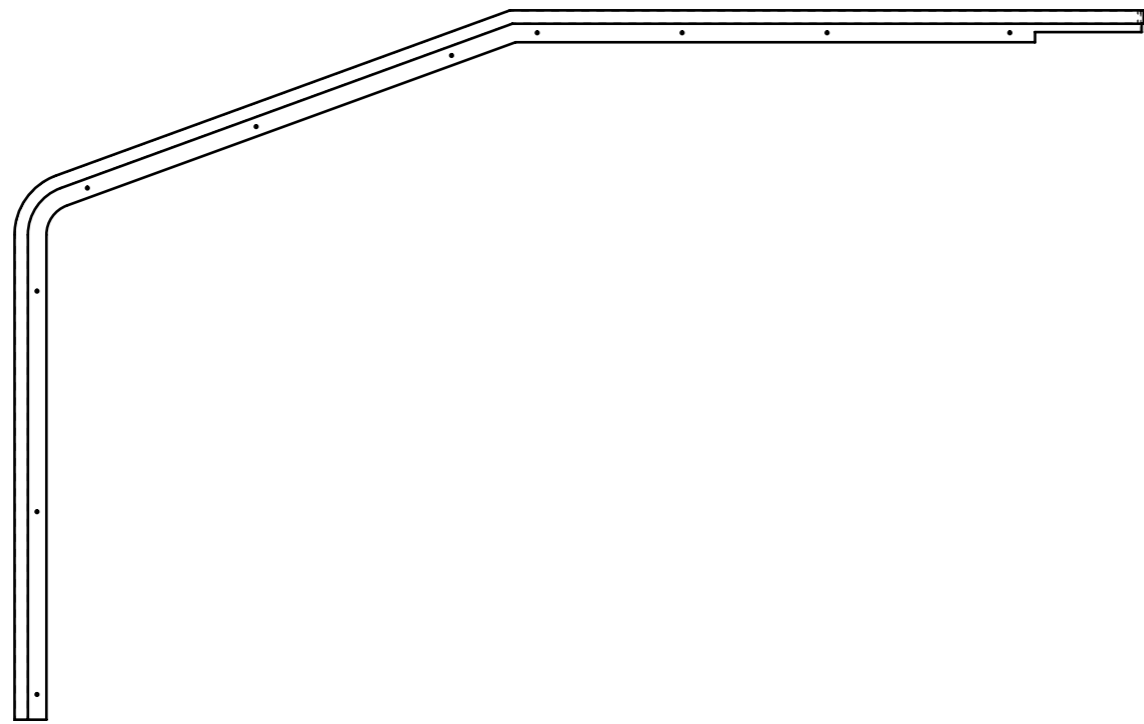

01

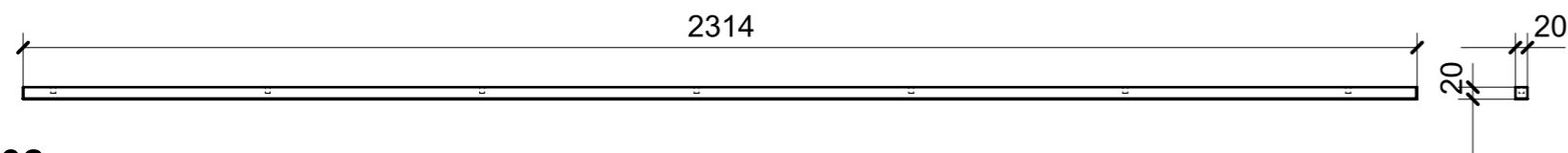
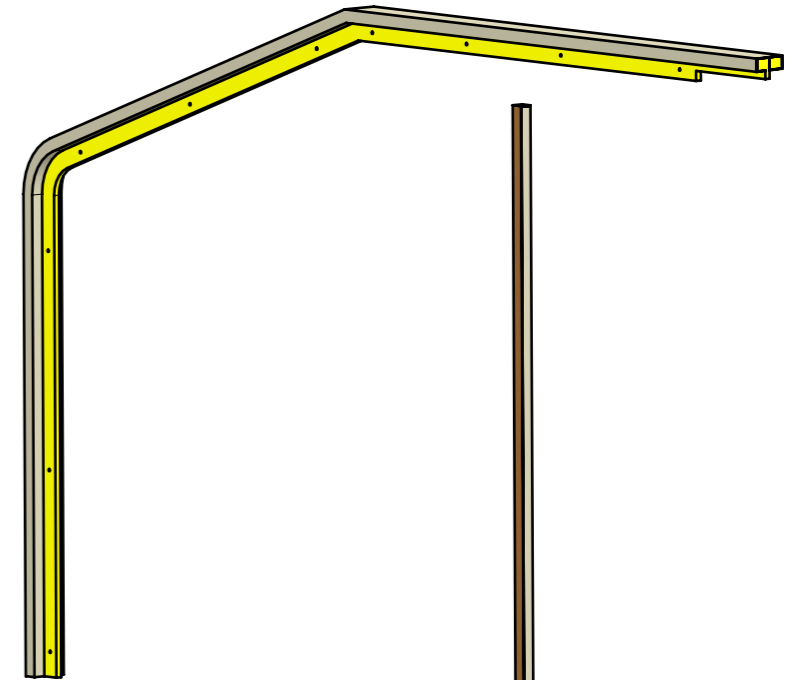
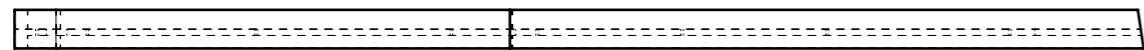

02

VERNICIATURA LASTRA/LACCATI:

● = VERNICIARE 1 LATO + FILI RASATI O BORDATI

NESSUN SIMBOLO = VERNICIARE 2 LATI + FILI RASATI O BORDATI

LOCALE	CODICE	DESCRIZIONE COMPONENTE	FINITURA	Q.TA
LOBBY	MD299_R01_CG01	RIV CORR. SX PORTA OSPITI	LASTRA SCURA	1

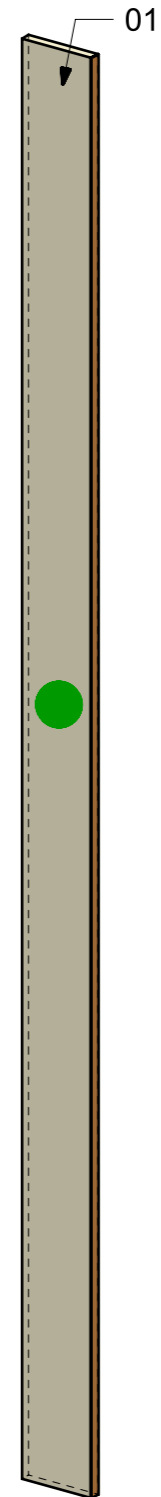
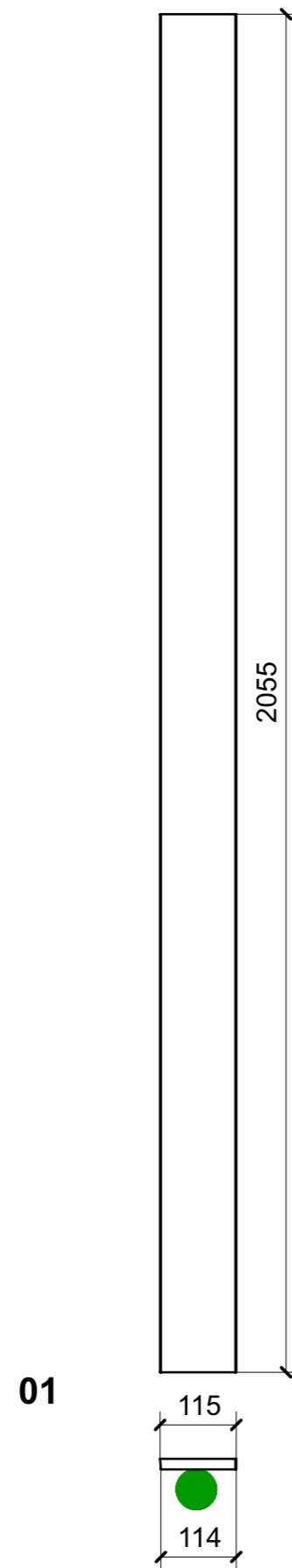

VERNICIATURA LASTRA/LACCATI:

● = VERNICIARE 1 LATO + FILI RASATI O BORDATI

NESSUN SIMBOLO = VERNICIARE 2 LATI + FILI RASATI O BORDATI

LOCALE	CODICE	DESCRIZIONE COMPONENTE	FINITURA	Q.TA
LOBBY	MD299_R01_CH01	RIV CORR. SX BAGNO	LASTRA SCURA	1

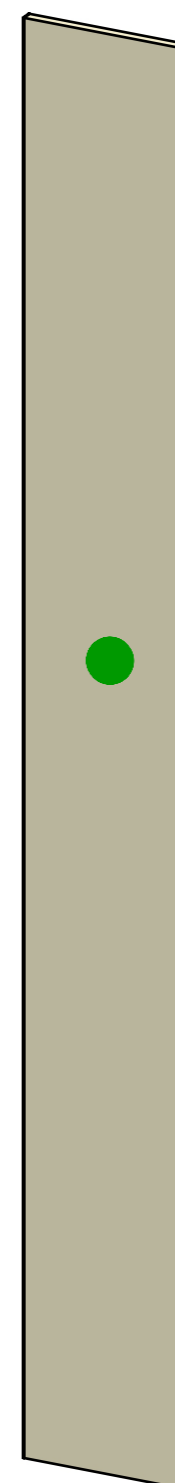
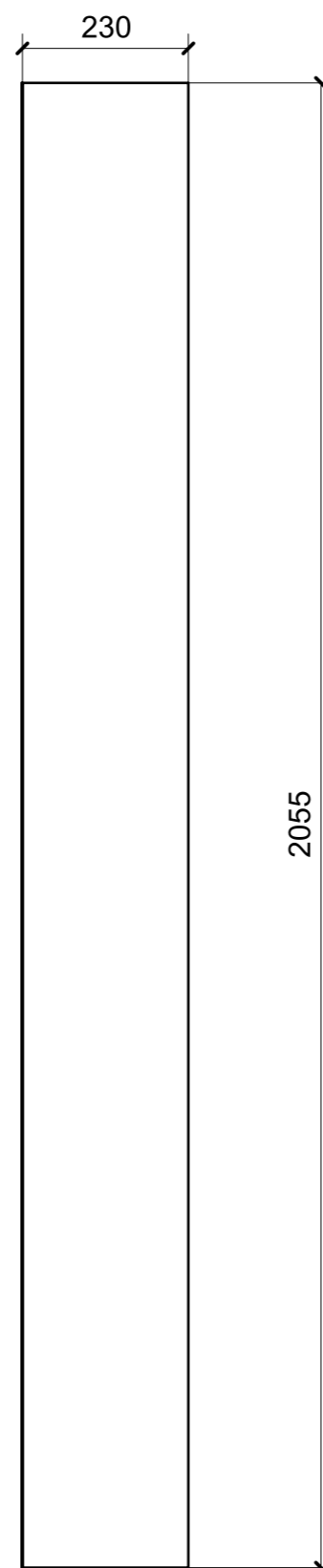

01

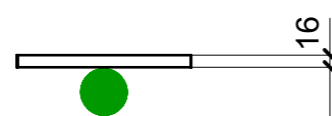

VERNICIATURA LASTRA/LACCATI:

● = VERNICIARE 1 LATO + FILI RASATI O BORDATI

NESSUN SIMBOLO = VERNICIARE 2 LATI + FILI RASATI O BORDATI

LOCALE	CODICE	DESCRIZIONE COMPONENTE	FINITURA	Q.TA
LOBBY	MD299_R01_CL01	RIV CORR. AD ANGOLO OSPITI DX	LASTRA SCURA	1

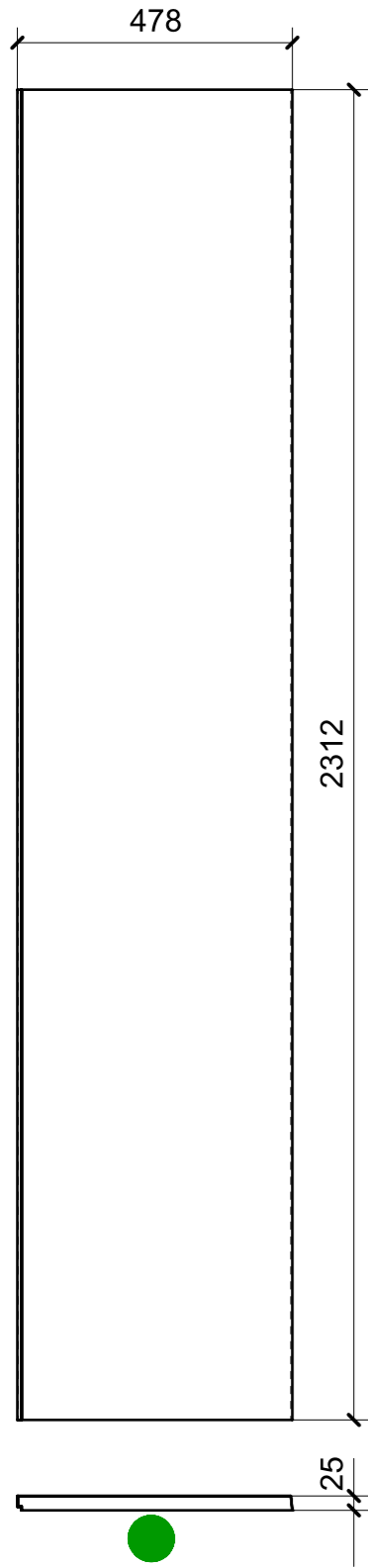

01

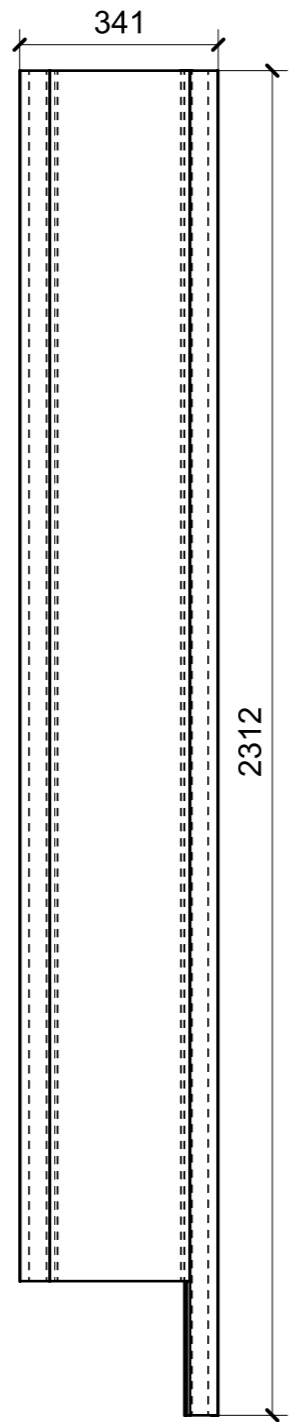

02

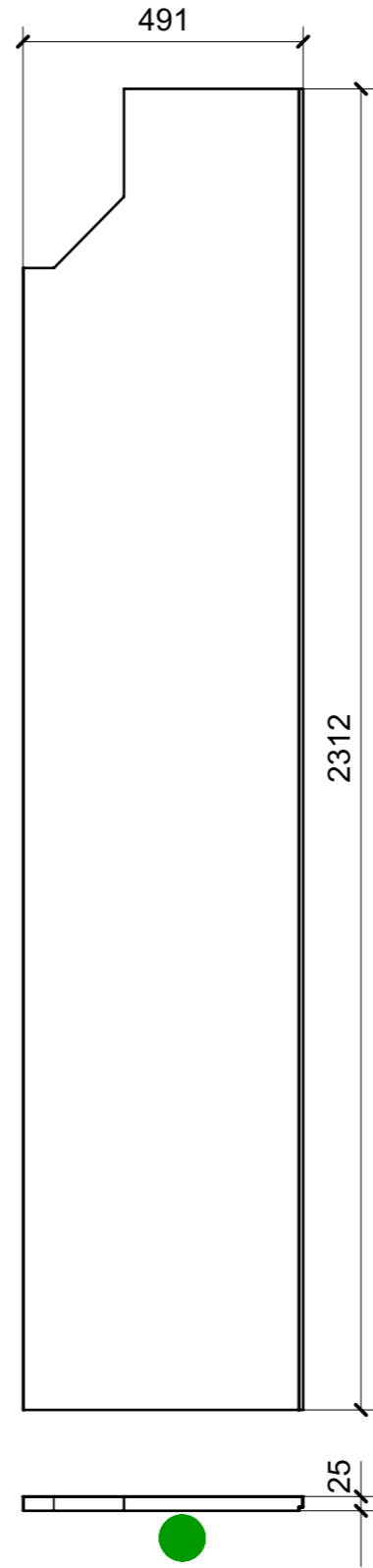

03

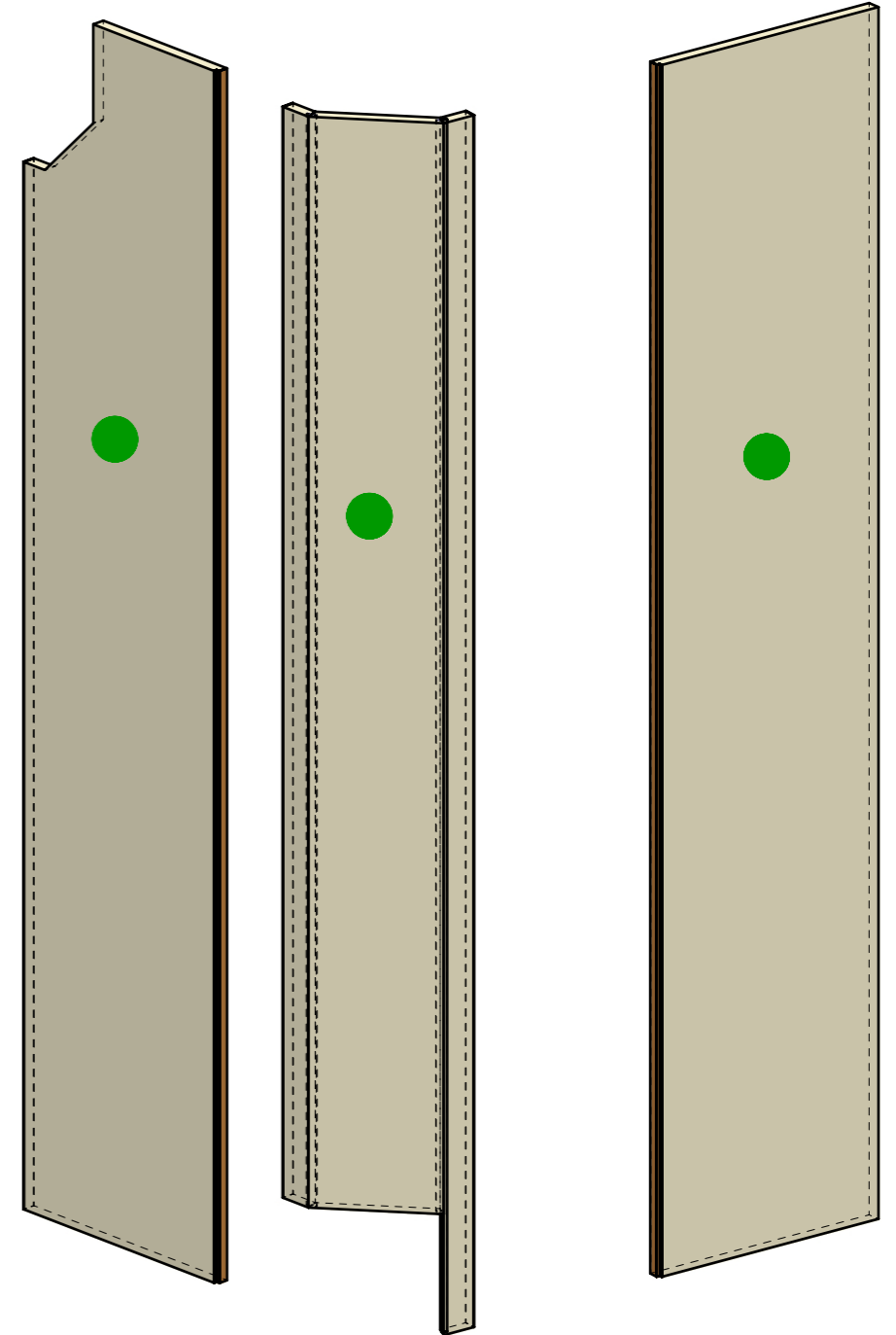

VERNICIATURA LASTRA/LACCATI:

● = VERNICIARE 1 LATO + FILI RASATI O BORDATI

NESSUN SIMBOLO = VERNICIARE 2 LATI + FILI RASATI O BORDATI

LOCALE	CODICE	DESCRIZIONE COMPONENTE	FINITURA	Q.TA
LOBBY	MD299_R01_CO01	RIV. GRADINI SALONE	LASTRA SCURA	1

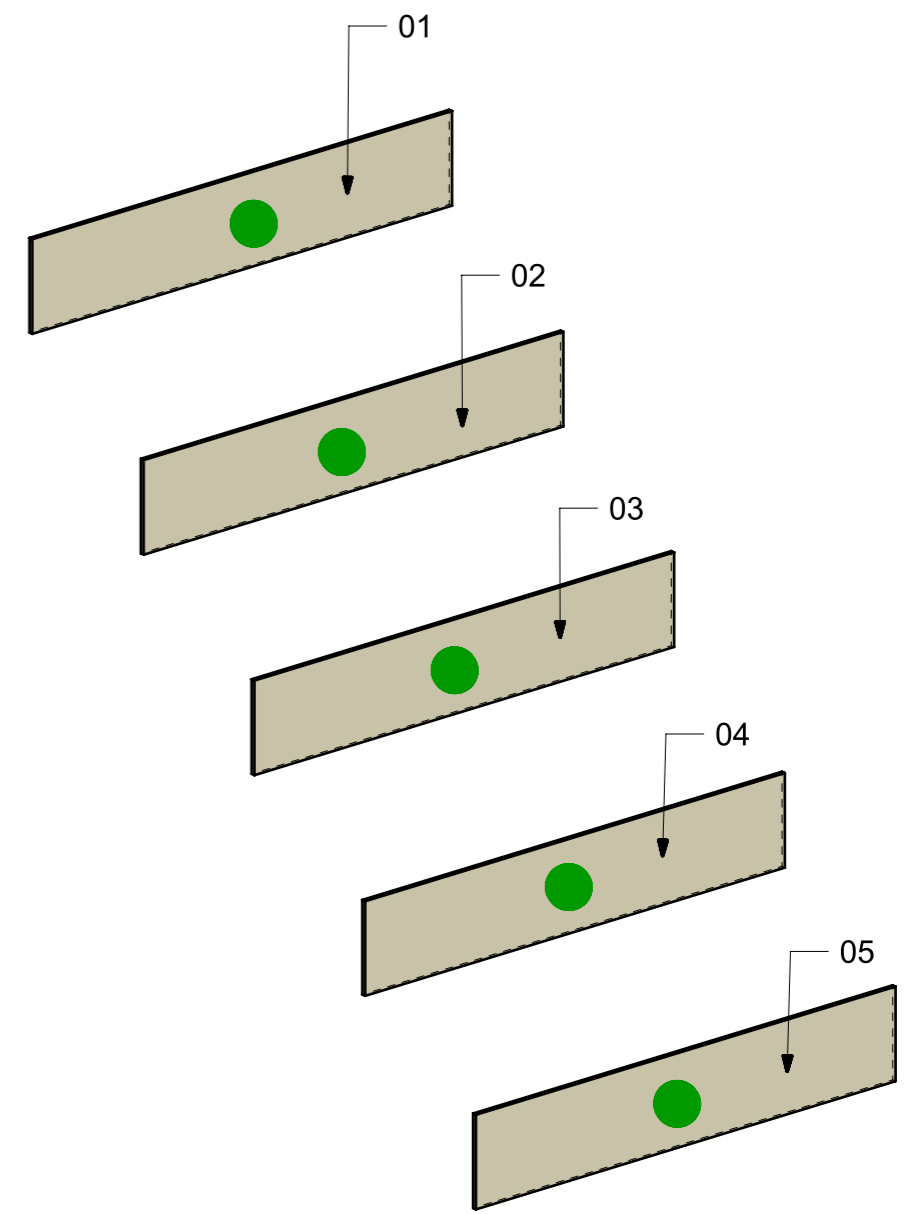
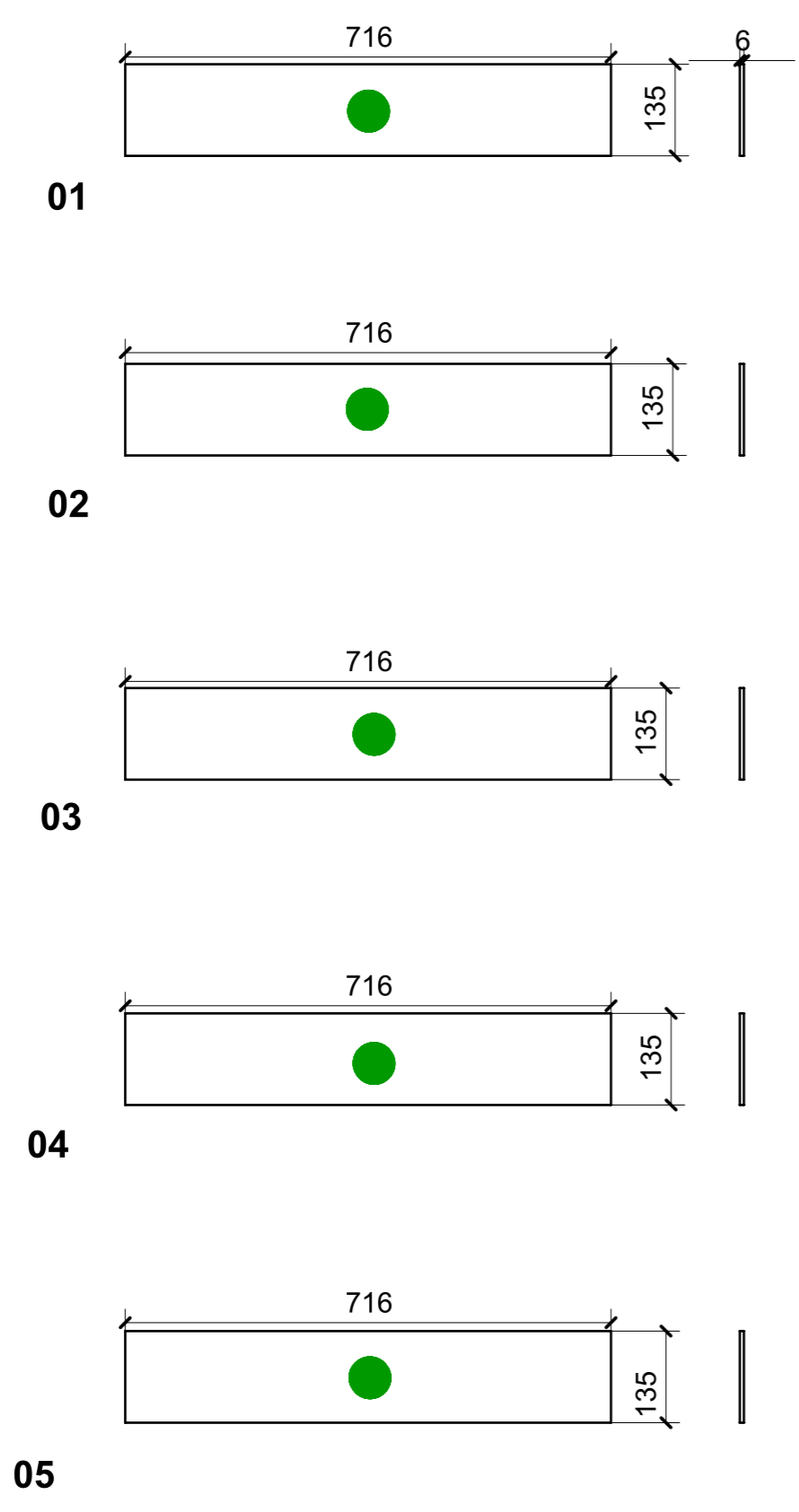

VERNICIATURA LASTRA/LACCATI:  
 ● = VERNICIARE 1 LATO + FILI RASATI O BORDATI      NESSUN SIMBOLO = VERNICIARE 2 LATI + FILI RASATI O BORDATI

LOCALE	CODICE	DESCRIZIONE COMPONENTE	FINITURA	Q.TA
LOBBY	MD299_R01_CP01	RIV. GRADINI ARMATORE	LASTRA SCURA	1

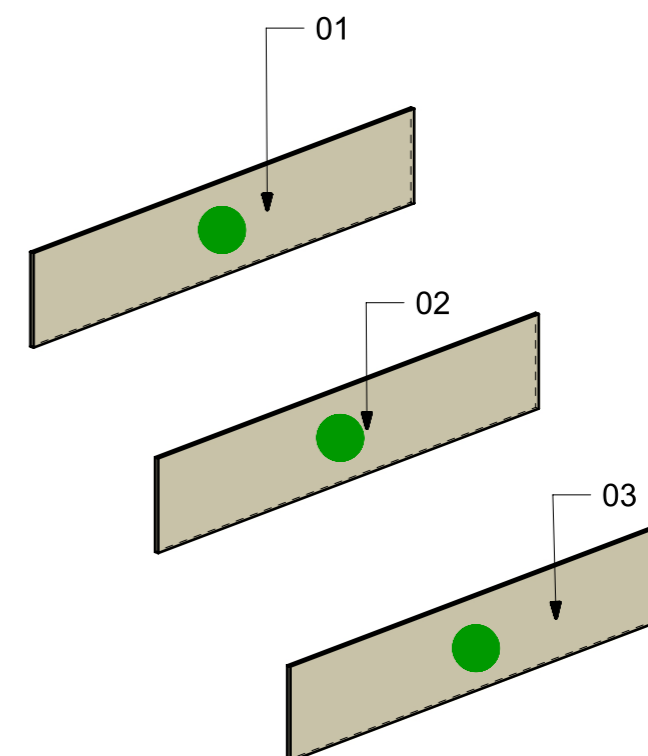
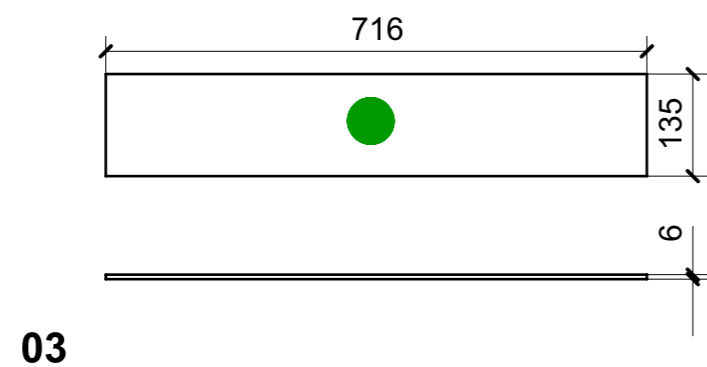
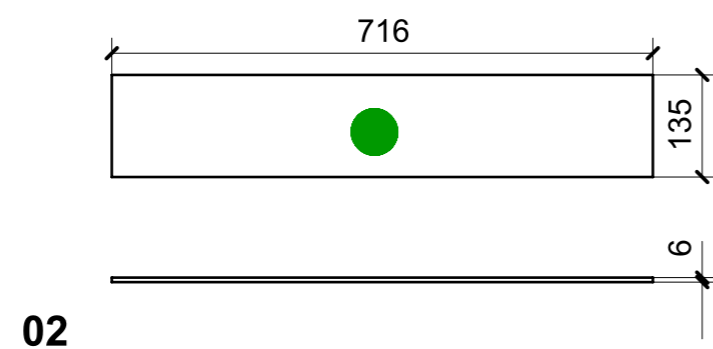
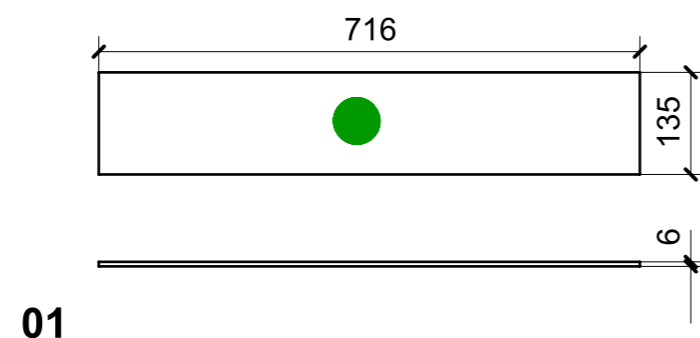

VERNICIATURA LASTRA/LACCATI:

● = VERNICIARE 1 LATO + FILI RASATI O BORDATI

NESSUN SIMBOLO = VERNICIARE 2 LATI + FILI RASATI O BORDATI