

# AZ26M

GR5

REV.9

LOCALE	CODICE	DESCRIZIONE COMPONENTE	FINITURA	Q.TA	OPERATORE
CABINA VIP SX	AZ26M-L01_VVA01	STRUTTURA MURATA TESTATA LETTO	LACCATO BIANCO RAL 9010	11	Damiano

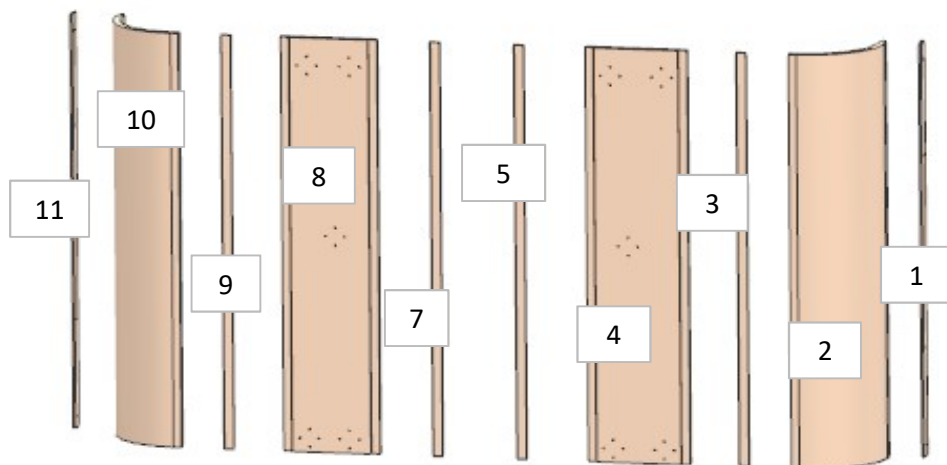

- 1 - 11 - L 40 x H 1160 x sp 6
- 2 - 10 - L 330 x H 1160 x sp 16
- 3 - 5 - 7 - 9 - L 25 x H 1160 x sp 6
- 4 - L 248 x H 1160 x sp 16
- 6 - L 1781 x H 1267 x sp 16
- 8 - L 263 x H 1160 x sp 16

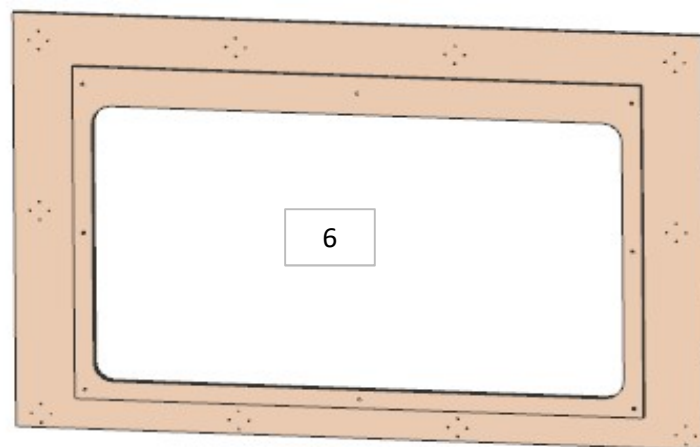

**ELEMENTO DA MONTARE con:  
R01\_VVA01  
e spedire con un unico imballo**

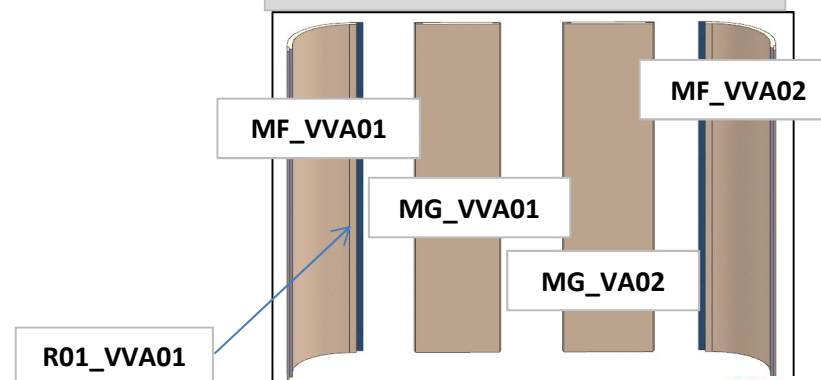

**consonni&c**

# AZ26M

MOD DA GR5

REV.9

LOCALE	CODICE	DESCRIZIONE COMPONENTE	FINITURA	Q.TA	OPERATORE
CABINA VIP SX	AZ26M-L02_VVA01	STRUTTURA MURATA TESTATA LETTO	LACCATO NCS S3020-Y30R	4	Damiano

1 - 3 - L.1451 x H.201 x sp 10  
2 - 4 - L. 934 x H.201 x sp 10

**MOD.146 DA GR.5 -  
MODIFICATA PROFONDITA'  
PANNELLI**

PER LUCIDATURA:  
1 LATO BELLO + TUTTI I FILI

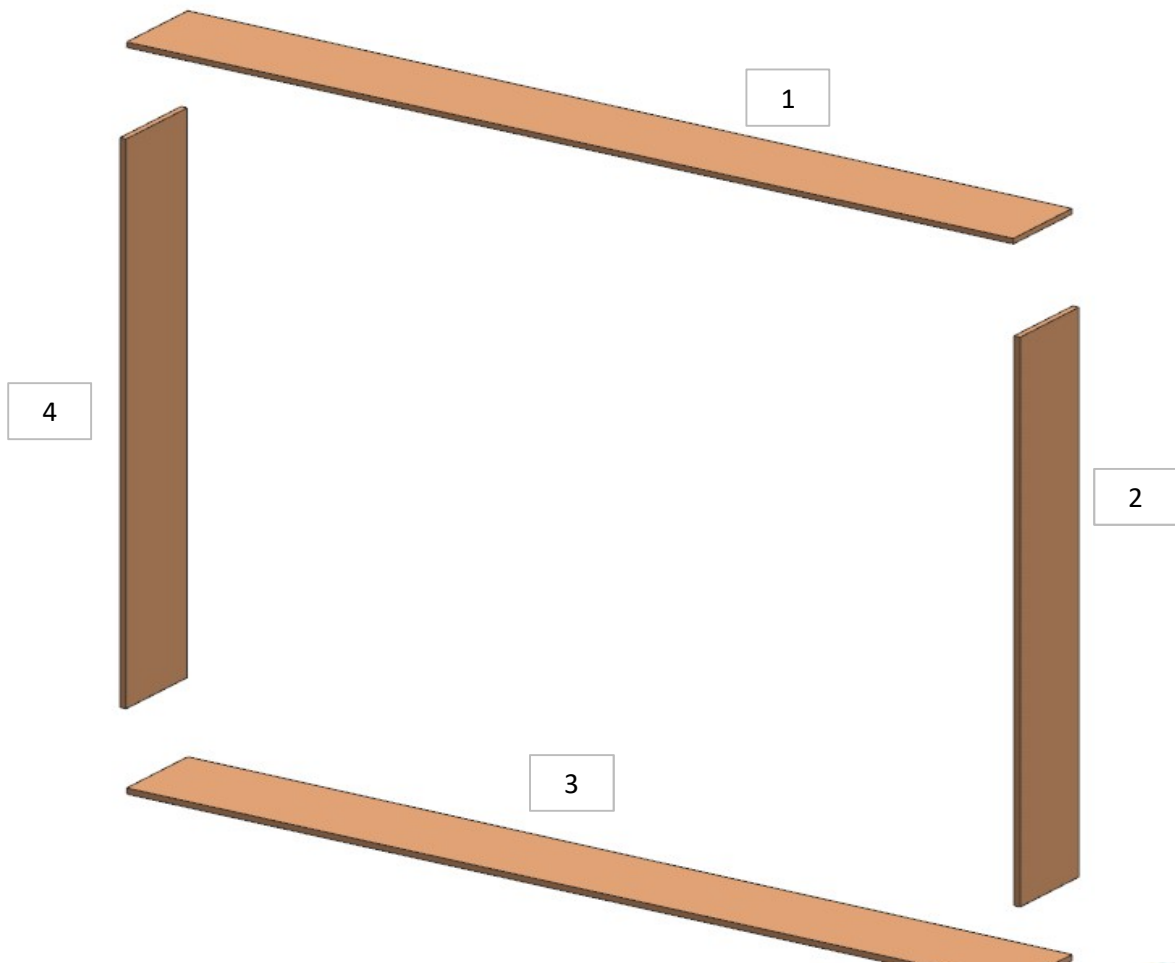

# AZ26M

## MOD GR4

REV.9

LOCALE	CODICE	DESCRIZIONE COMPONENTE	FINITURA	Q.TA	OPERATORE
CABINA VIP SX	AZ26M-L01_VVB01	COMODINO PRUA	LACCATO BIANCO RAL 9016	4	Damiano

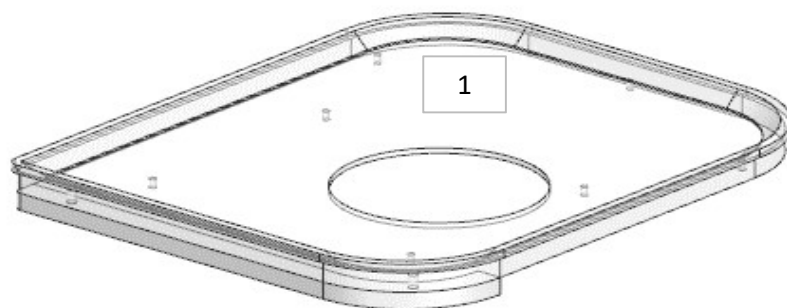

- 1 - L.511 x H 428 x sp 28
- 2 - L.320 x H 132 x 360
- 3 - L 314 x H 150 x sp 16
- 4 - L.340 x H 132 x sp 16

CASSETTO  
DIVENTATO  
LACCATO

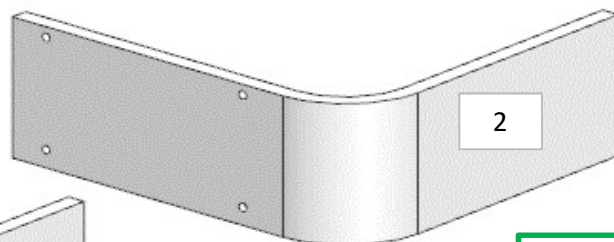

ELEMENTO DA MONTARE con:  
VVB01  
L01\_VVB01  
e spedire con un unico imballo

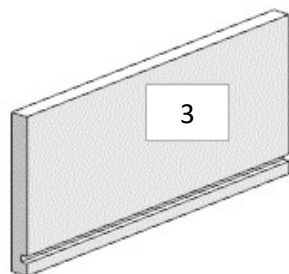

mod int 12  
cambiato laccato  
mogano in laminato  
bordeaux

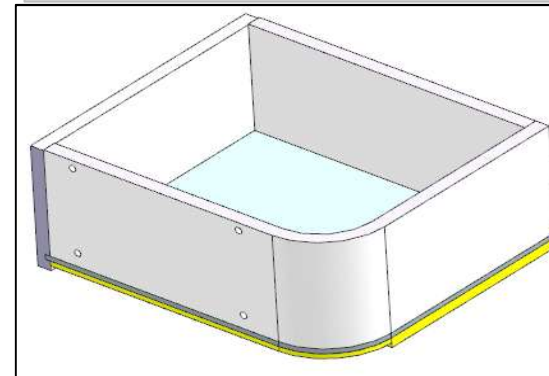
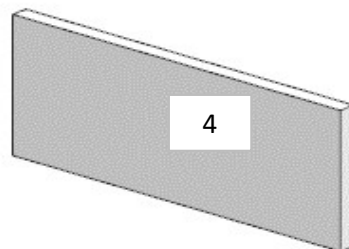

# AZ26M

## MOD GR4

REV.9

LOCALE	CODICE	DESCRIZIONE COMPONENTE	FINITURA	Q.TA	OPERATORE
CABINA VIP SX	AZ26M-L02_VVB01	COMODINO PRUA	LACCATO NCS S3020-Y30R	4	Damiano

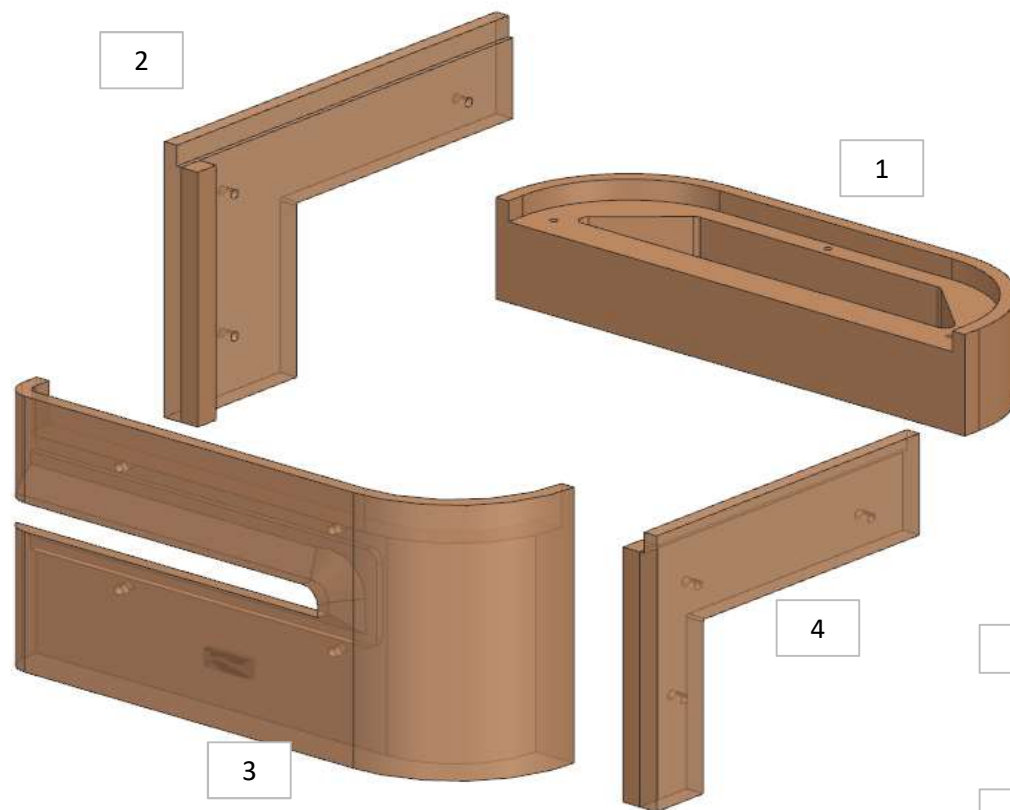

- 1 - L 446 x H 88 x 127
- 2 - L 365 x H 238 x sp 16
- 3 - SVILUPPO L. 533 x H.238 x sp 32
- 4 - L 288 x H 238 x sp 16

**ELEMENTO DA MONTARE con:**  
**L01\_VVB01**  
**VVB01**  
**L03\_VVB01**  
**X01\_VVB01**  
 e spedire con un unico imballo

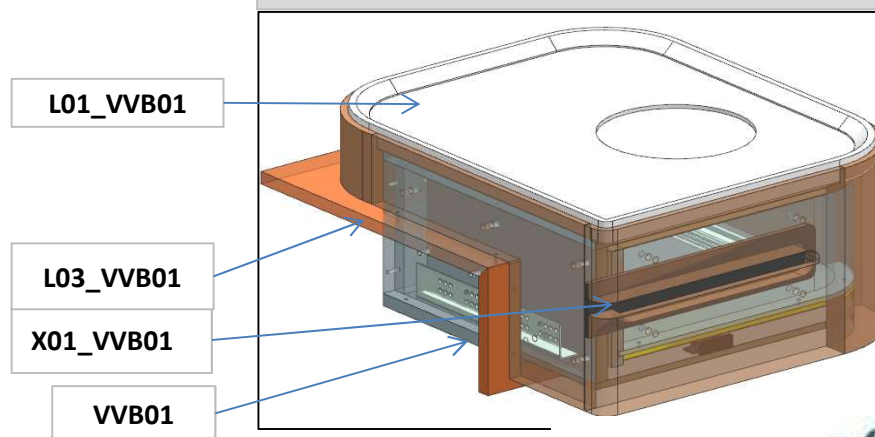

# AZ26M

## MOD GR4

REV.9

LOCALE	CODICE	DESCRIZIONE COMPONENTE	FINITURA	Q.TA	OPERATORE
CABINA VIP SX	AZ26M-L03_VVB01	COMODINO PRUA	LACCATO BRONZO	3	Damiano

- 1 - L.499 x H.394 x sp 16
- 2 - L.44 x H.150 x sp 16
- 3 - L.40 x H.150 x sp 16

ELEMENTO DA MONTARE con:  
**L01\_VVB01**  
**L02\_VVB01**  
**VVB01**  
**X01\_VVB01**  
e spedire con un unico imballo

PARTE FRONTALE ERA A "U"  
ADESSO DIVISA IN 2 PZ.

L01\_VVB01

VVB01

X01\_VVB01

L02\_VVB01

consonni&c

# AZ26M

REV. 01-2023

LOCALE	CODICE	DESCRIZIONE COMPONENTE	FINITURA	Q.TA	OPERATORE
CABINA VIP SX	AZ26M-L04_VVB01	COMODINO PRUA	LACCATO MOGANO 100 gloss	1	Damiano

1 - L 329 x H 84,5 x sp 6

**DIVENTATO**  
**LAMINATO**

NTARE con:

01

01

01

ico imballo

L01\_VVB01

L03\_VVB01

VVB01

L02\_VVB01

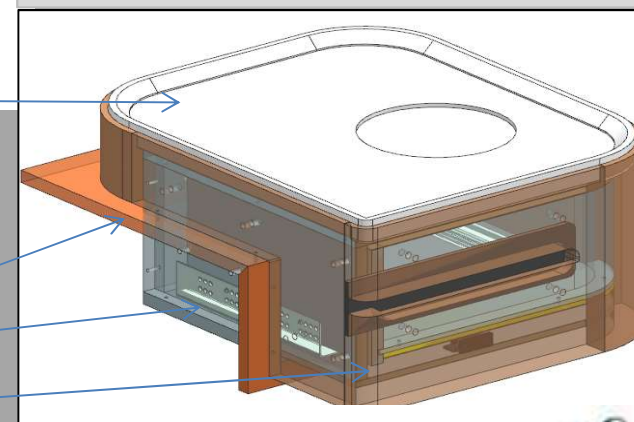

consonni&c

# AZ26M

MOD GR4

REV.9

LOCALE	CODICE	DESCRIZIONE COMPONENTE	FINITURA	Q.TA	OPERATORE
CABINA VIP SX	AZ26M-L01_VVD01	COMODINO POPPA	LACCATO BIANCO RAL 9016	4	Damiano

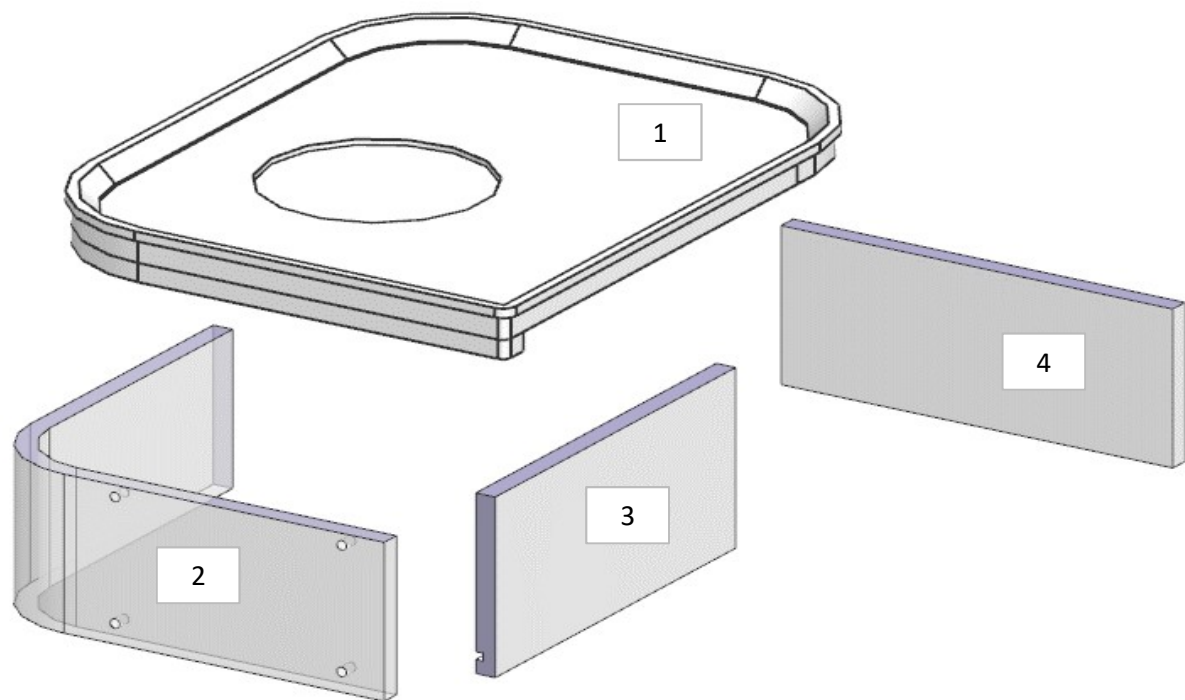

- 1 - L 411 x H 512 x sp 28
- 2 - L 344 x H 133 x sp 16
- 3 - L 323 x H 133 x sp 16
- 4 - L 315 x H 150 x sp 16

**ELEMENTO DA MONTARE con:  
VVD01  
L01\_VVD01  
e spedire con un unico imballo**

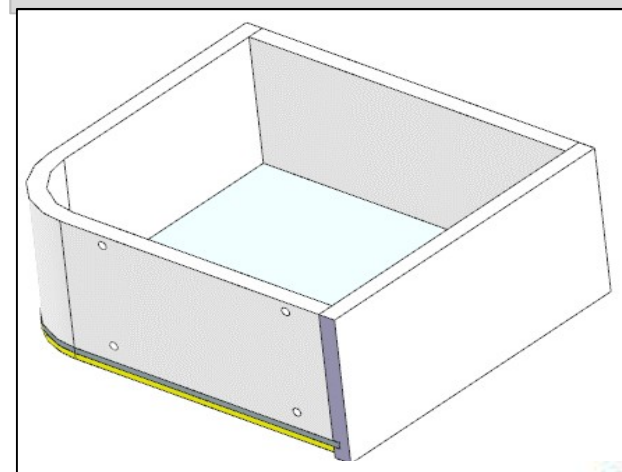

**consonni&c**

# AZ26M

DA MAT. 14

REV.9

LOCALE	CODICE	DESCRIZIONE COMPONENTE	FINITURA	Q.TA	OPERATORE
CABINA VIP SX	AZ26M-L02_VVD01	COMODINO POPPA	LACCATO NCS S3020-Y30R	4	Damiano

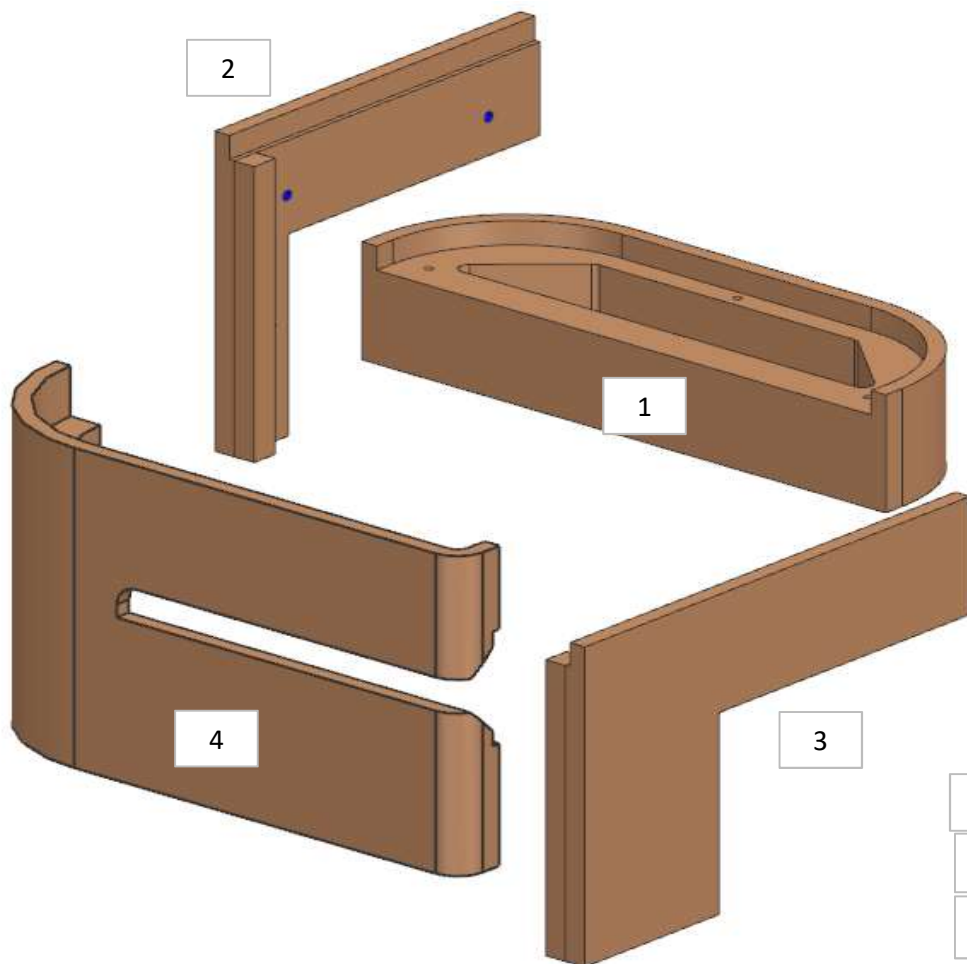

- 1 - L 429 x H 88 x 128
- 2 - L 289 x H 237 x sp 16
- 3 - L 365 x H 238 x sp 16
- 4 - SVILUPPO L. 516 x H.238 x sp 32

**ELEMENTO DA MONTARE con:**  
**L01\_VVD01**  
**VVD01**  
**L03\_VVD01**  
**L04\_VVD01**  
**e spedire con un unico imballo**

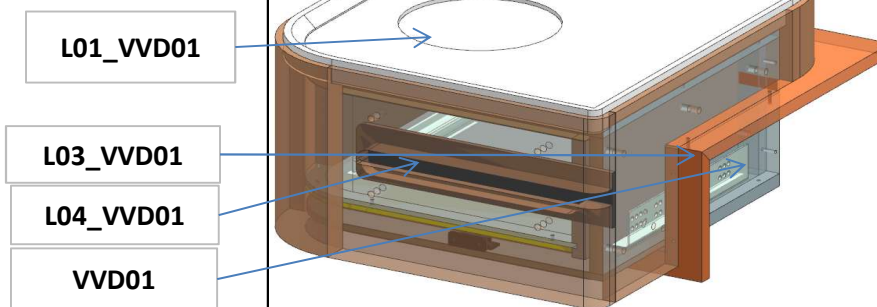

# AZ26M

DA MAT. 14

REV.9

LOCALE	CODICE	DESCRIZIONE COMPONENTE	FINITURA	Q.TA	OPERATORE
CABINA VIP SX	AZ26M-L03_VVD01	COMODINO POPPA	LACCATO BRONZO	3	Damiano

1 - L.441 x H 393 x sp 16  
2 - 3 - L.44 x H 150 x sp 16

ELEMENTO DA MONTARE con:  
L01\_VVD01  
L02\_VVD01  
VVD01  
L04\_VVD01

PARTE FRONTALE ERA A "U"  
ADESSO DIVISA IN 2 PZ.

L01\_VVD01

VVD01

L04\_VVD01

L02\_VVD01

consonni&c

# AZ26M

REV. 01-2023

LOCALE	CODICE	DESCRIZIONE COMPONENTE	FINITURA	Q.TA	OPERATORE
CABINA VIP SX	AZ26M-L04_VVD01	COMODINO POPPA	LACCATO MOGANO 100 gloss	1	Damiano

1 - L 311 x H 84,5 x sp 6

**DIVENTATO**  
**LAMINATO**

DA MONTARE con:  
L01\_VVD01  
L02\_VVD01  
L03\_VVD01  
VVD01  
in un unico imballo

L01\_VVD01

L03\_VVD01

VVD01

L02\_VVD01

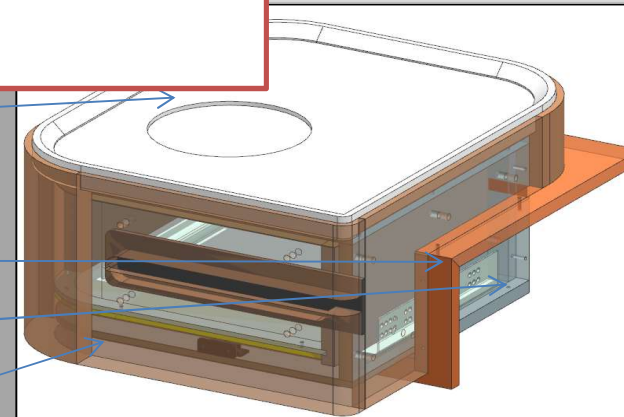

**consonni&c**

# AZ26M

## MOD DA GR9

REV.9

LOCALE	CODICE	DESCRIZIONE COMPONENTE	FINITURA	Q.TA	OPERATORE
CABINA VIP SX	AZ26M-L01_VVE01	RIVESTIMENTO PARETI PRUA	LACCATO BIANCO RAL 9010	2	Damiano

1 - L 486 x H 1624 x sp 10  
2 - L 293 x H 414 x sp 10

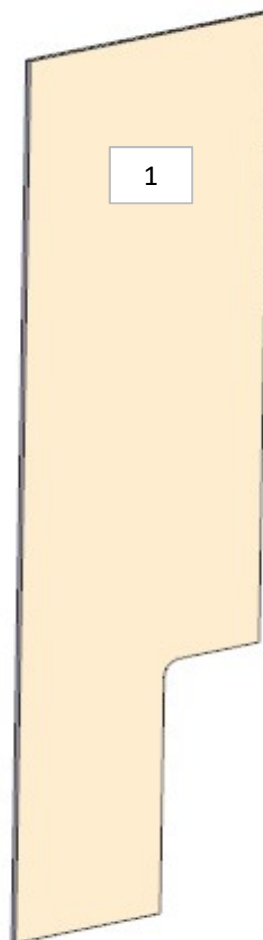
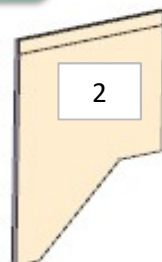

MOD AZ 216  
ALLUNGATO  
RIVESTIMENTI VERSO  
PAVIMENTO ED  
ELIMINATO LAMINATI

ELEMENTO DA MONTARE  
con:  
**X01\_VVE01**  
**A01\_VVE01**  
e spedire con un unico  
imballo

A01\_VVE01



**consonni&c**

# AZ26M

MOD DA GR9

REV.9

LOCALE	CODICE	DESCRIZIONE COMPONENTE	FINITURA	Q.TA	OPERATORE
CABINA VIP SX	AZ26M-L01_VVF01	RIVESTIMENTO PARETI POPPA	LACCATO BIANCO RAL 9010	2	Damiano

1 - L 486 x H 1624 x sp 10  
2 - L 293 x H 444 x sp 10

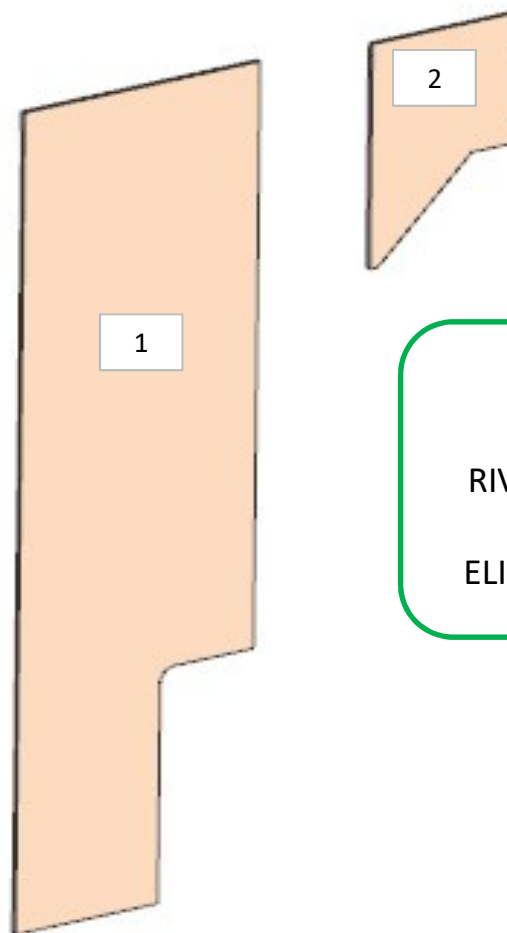

MOD AZ 216  
ALLUNGATO  
RIVESTIMENTI VERSO  
PAVIMENTO ED  
ELIMINATO LAMINATI

ELEMENTO DA  
MONTARE con:  
**X01\_VVF01**  
**A01\_VVF01**  
e spedire con un unico  
imballo

A01\_VVF01

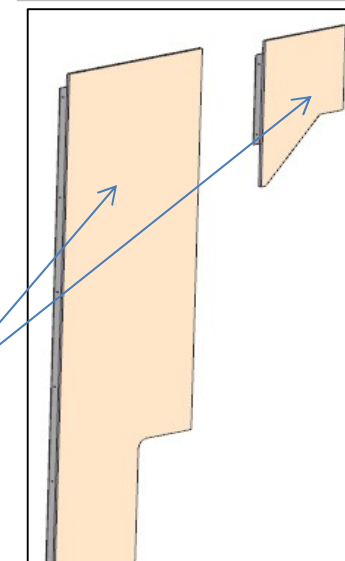

consonni&c

# AZ26M

MOD DA GR10

REV.10

LOCALE	CODICE	DESCRIZIONE COMPONENTE	FINITURA	Q.TA	OPERATORE
CABINA VIP SX	AZ26M-L01_VVG01	RIVESTIMENTO PARETI CENTRO NAVE	LACCATO BIANCO RAL 9010	9	Damiano

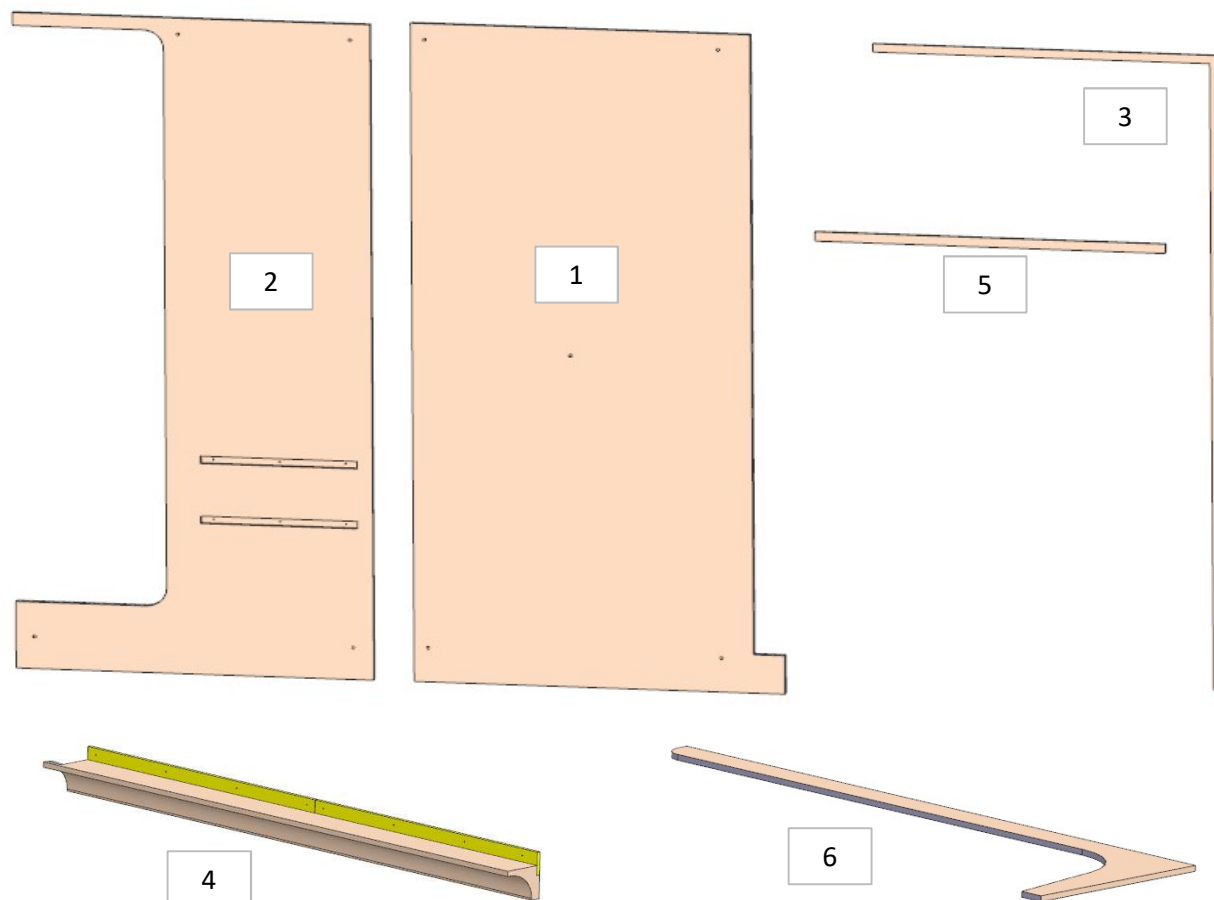

**ELEMENTO DA MONTARE con:**  
MG\_VVG01  
MG\_VVG02  
e spedire con un unico imballo

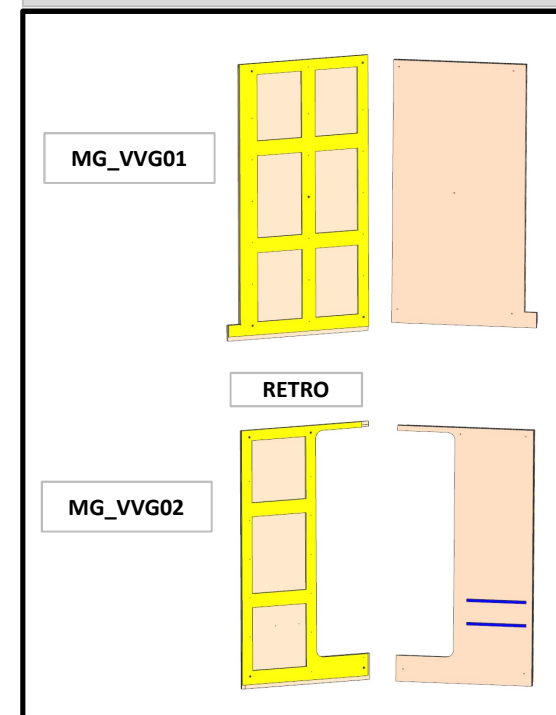

**consonni&c**

# AZ26M

MOD DA GR4

REV.9

LOCALE	CODICE	DESCRIZIONE COMPONENTE	FINITURA	Q.TA	OPERATORE
CABINA VIP SX	AZ26M-L01_VVH01	CORNICE TV	LACCATO BRONZO	9	Damiano

- 1-3-5-7 - L.65 x H.84 x sp 16
- 2-6- L.65 x H.940 x sp 16
- 8-4- L.65 x H.1548 x sp 16
- 9- L.1024 x H.1632 x sp 75

MOD INT 14 - AZ 115  
MODIFICATA DIVISIONE  
CORNICE

ELEMENTO DA MONTARE  
con:  
VVH01  
e spedire con un unico  
imballo

BORDATO  
BRONZO

SPRUZZARE  
DI NERO

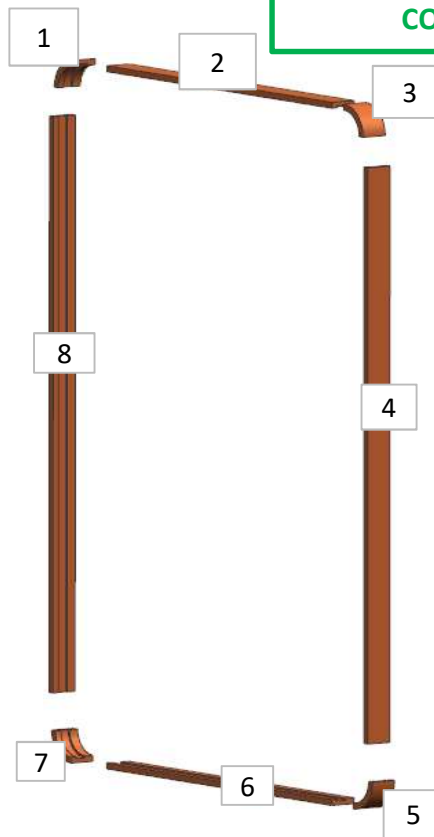
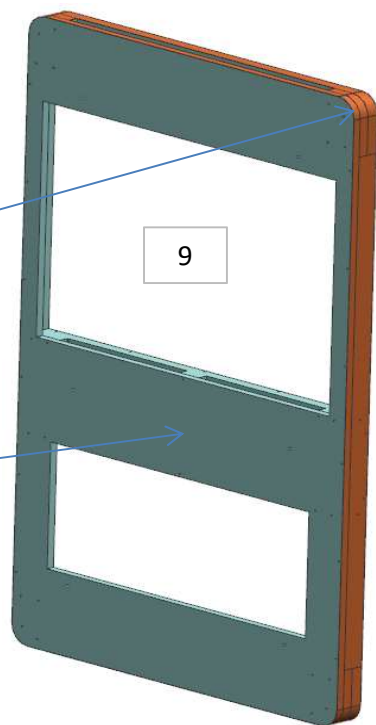

VVH01

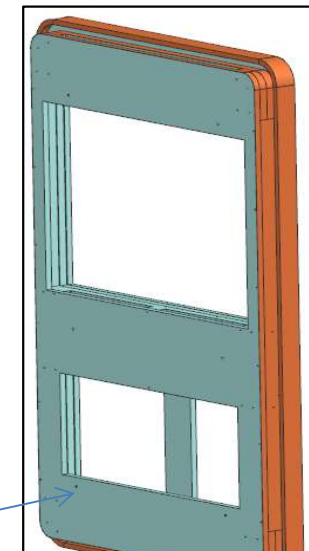

# AZ26M

MOD DA GR7

REV.9

LOCALE	CODICE	DESCRIZIONE COMPONENTE	FINITURA	Q.TA	OPERATORE
CABINA VIP SX	AZ26M-L01_VVI01	ARMADIO	LACCATO MOGANO (precomposto) 100 gloss	5	Damiano

- 1 - L.574 x H.1749 x sp 25
- 2 - L.616 x H.1836 x sp 25
- 3 - L. 616 x H.85 x sp 25
- 4 - L. 498 x H.131 x sp 25
- 5 - L. 26 x H.1718 x sp 25

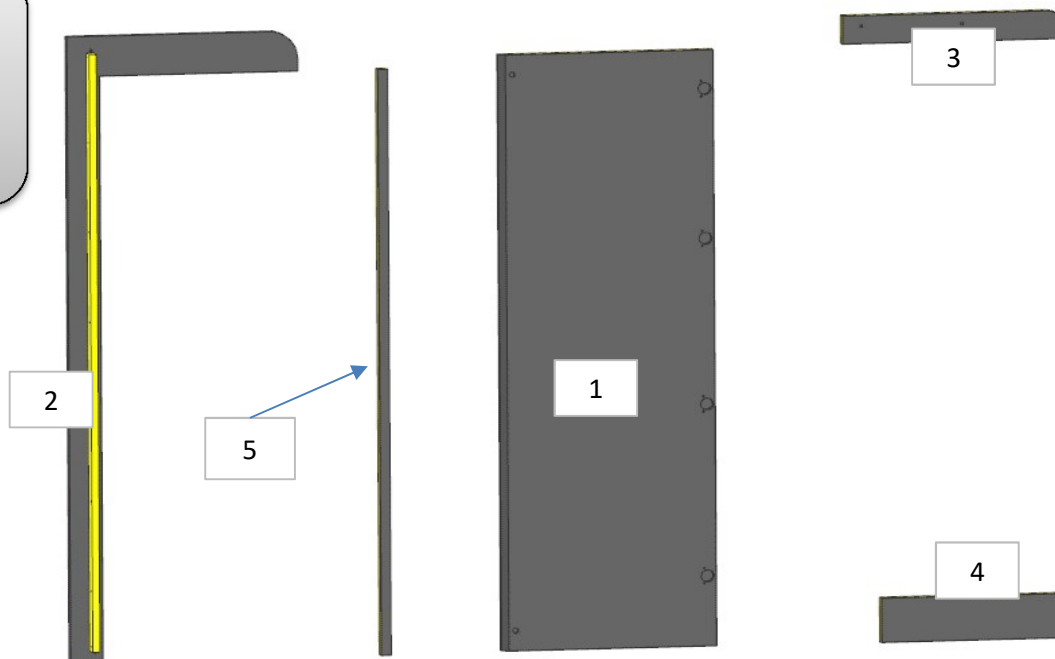

**MOD.INT 06**  
**- MODIFICATO PEZZO 2 - 3**  
**- AGGIUNTO COMP 4 - 5**  
**RIMOSSO IL 'MONTATO FINITO'**

# AZ26M

DA MAT. 14

REV.9

LOCALE	CODICE	DESCRIZIONE COMPONENTE	FINITURA	Q.TA	OPERATORE
CABINA VIP SX	AZ26M-L01_VVL01	VASSOIO RIVISTE	LACCATO BRONZO	3	Damiano

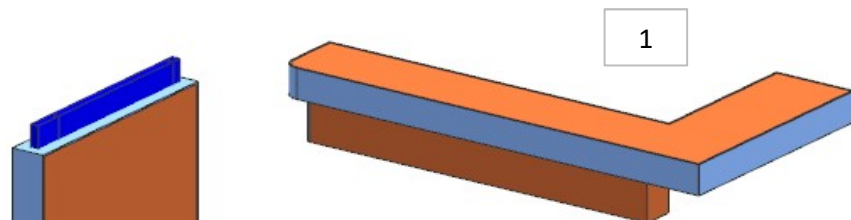

- 1 - L.219 x H 115 x 46
- 2 - L.115 x H 184 x sp 16
- 3 - L.115 x H 490 x sp 16

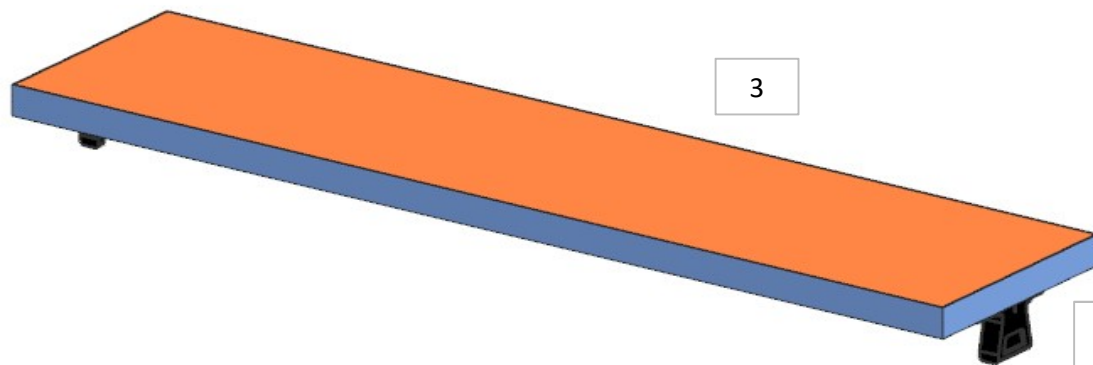

ELEMENTO DA MONTARE con:  
VVL01  
L02\_VVL01  
e spedire con un unico imballo

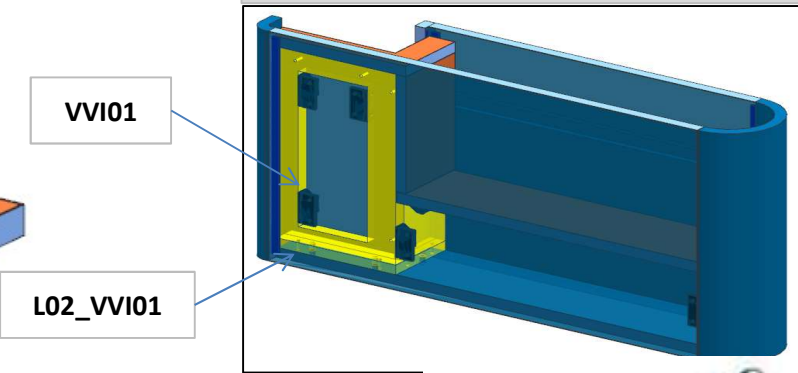

# AZ26M

DA MAT. 14

REV.9

LOCALE	CODICE	DESCRIZIONE COMPONENTE	FINITURA	Q.TA	OPERATORE
CABINA VIP SX	AZ26M-L02_VVL01	VASSOIO RIVISTE	LACCATO NCS S4040-R80B (BLU)	4	Damiano

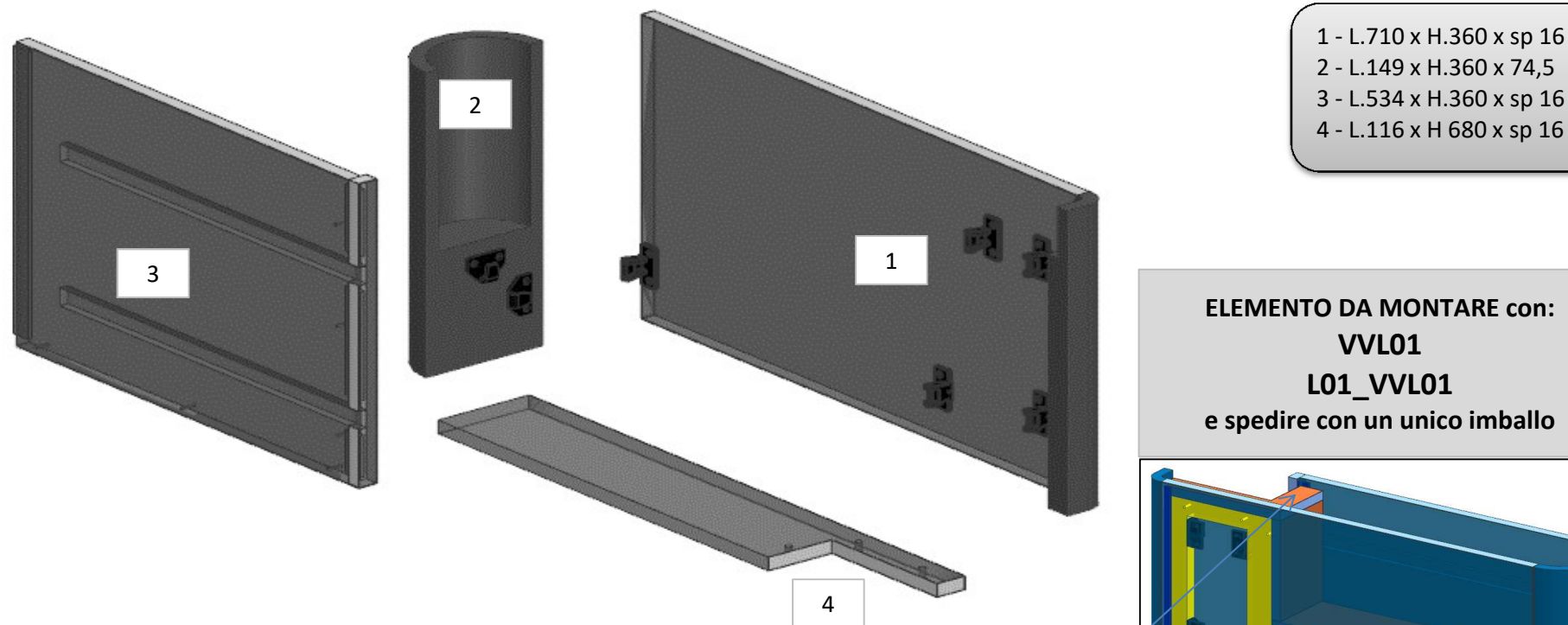

**ELEMENTO DA MONTARE con:**  
**VVL01**  
**L01\_VVL01**  
 e spedire con un unico imballo

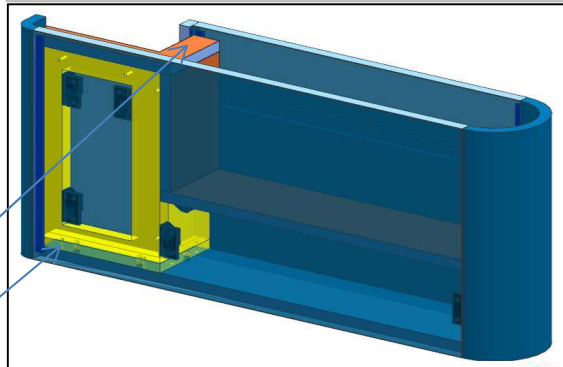

**CAPRI:** AZZURRO - NCS S4040-R80B OPACO  
**RIVIERA:** VIOLA CHIARO - NCS S2010-R70B OPACO  
**NEUTRO:** MASTROTTO SABBIA 628 - NCS S3020-Y30R OPACO

L02\_VVI01  
 VVI01

# AZ26M

MOD DA GR10

REV. GR 10

LOCALE	CODICE	DESCRIZIONE COMPONENTE	FINITURA	Q.TA	OPERATORE
CABINA VIP SX	AZ26M-L01_VVM01	CIELINO	LACCATO BIANCO RAL 9016	7	Damiano

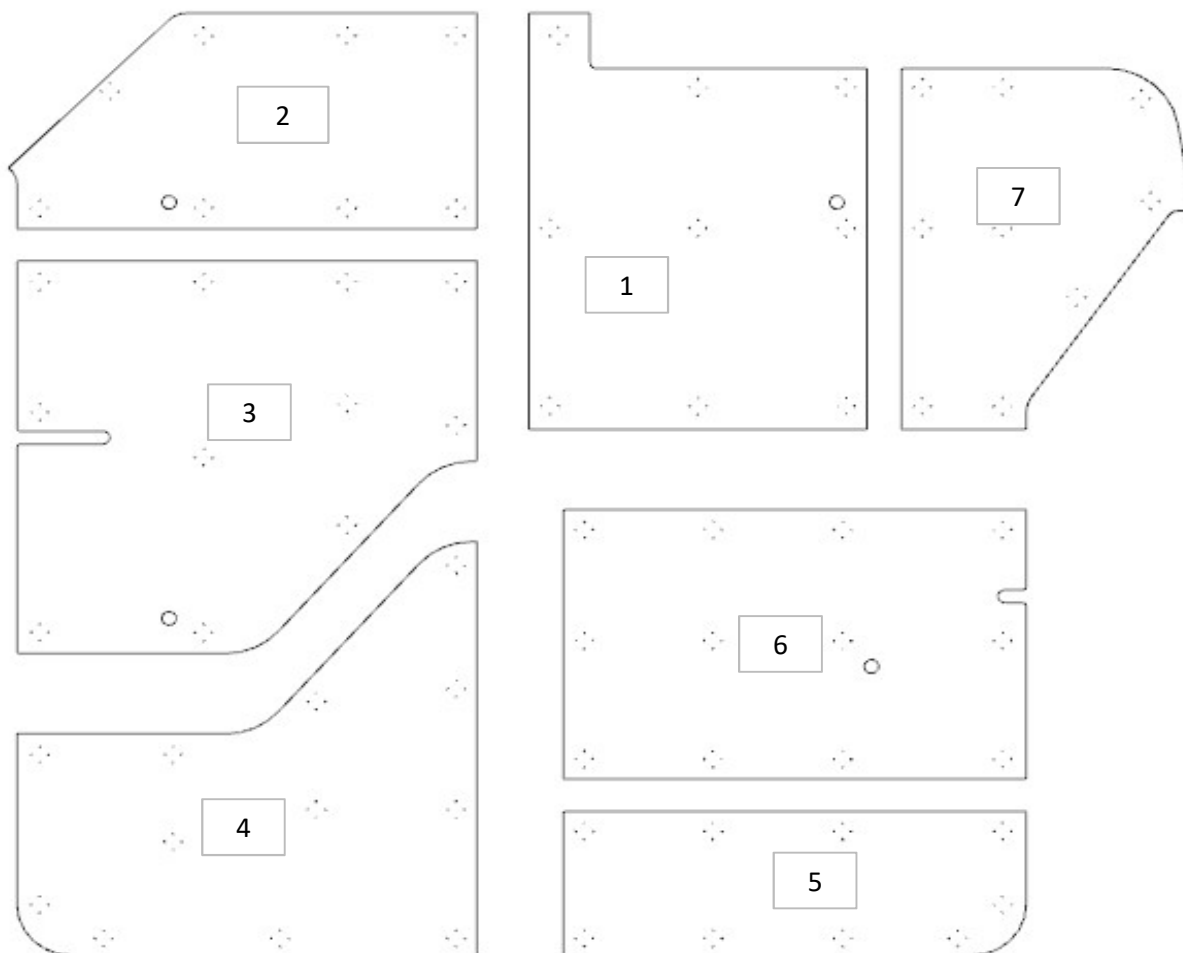

MOD AZ 268  
AGGIUNTI 3 PEZZI

- 1 - L.1288 x H 975 x sp 10
- 2 - L.1354 x H 671 x sp 10
- 3 - L.1223 x H 1328 x sp 10
- 4 - L.1290 x H 1328 x sp 10
- 5 - L.1366 x H 454 x sp 10
- 6 - L.1336 x H 834 x sp 10
- 7 - L.1125 x H 841 x sp 10

PER LUCIDATURA:  
1 LATO BELLO + TUTTI I FILI

**consonni&c**

# AZ26M

MOD DA GR5

REV.9

LOCALE	CODICE	DESCRIZIONE COMPONENTE	FINITURA	Q.TA	OPERATORE
CABINA VIP SX	AZ26M-L01_VVN01	PLENUM ARMADIO	LACCATO BRONZO	4	Damiano

**MOD.230 DA GR.5**  
**- MASCHERINA PLENUM**  
**SCOMPOSTA IN 4 PEZZI.**  
**COSEGNARE DIVISI.**

**ELEMENTO DA MONTARE:**  
**MG\_VVN01**  
 e spedire con un unico imballo

PER LUCIDATURA:  
 VERIFICARE SE LATO BELLO  
 LASTRATO

VERIFICARE PRESENZA LAMELLO  
 TRA PEZZI N.3 E N.4

PER LUCIDATURA:  
 1 LATO BELLO + TUTTI I FILI - LUCIDARE BENE INERNO ASOLE

- 1 - L.282 x H 76 x sp 30
- 2 - SVILUPPO 312 x H 76 x sp 30
- 3 - L.1383 x H 76 x sp 30
- 4 - L.150 x H 76 x sp 30

# AZ26M

REV.9

LOCALE	CODICE	DESCRIZIONE COMPONENTE	FINITURA	Q.TA	OPERATORE
CABINA VIP SX	AZ26M-L01_VVR01	PORTAGIOIE COMODINO POPPA-OPT		3	Damiano

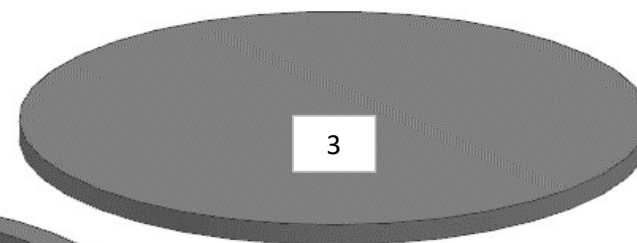
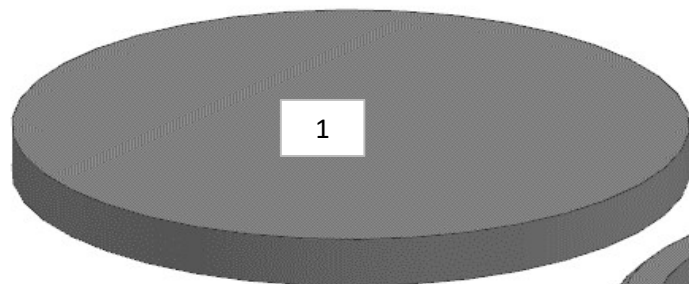

**ELEMENTO DA MONTARE:  
MG\_VR01  
e spedire con un unico imballo**

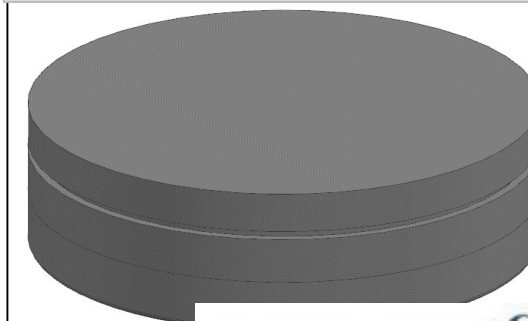

**CAPRI:** BLU- NCS S4050-R70B 100 gloss  
**RIVIERA:** BLU- NCS S4050-R70B 100 gloss  
**NEUTRO** - LACCATO BRONZO DA CAMPIONE

**consonni&c**

# AZ26M

REV.9

LOCALE	CODICE	DESCRIZIONE COMPONENTE	FINITURA	Q.TA	OPERATORE
CABINA VIP SX	AZ26M-L01_VVQ01	PORTAGIOIE COMODINO PRUA -OPT		3	Damiano

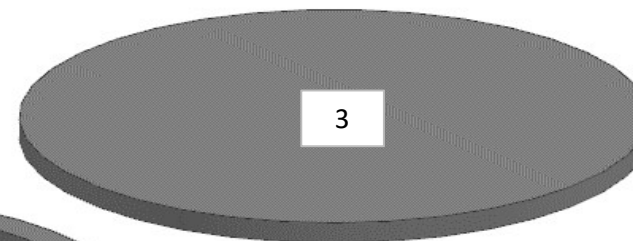
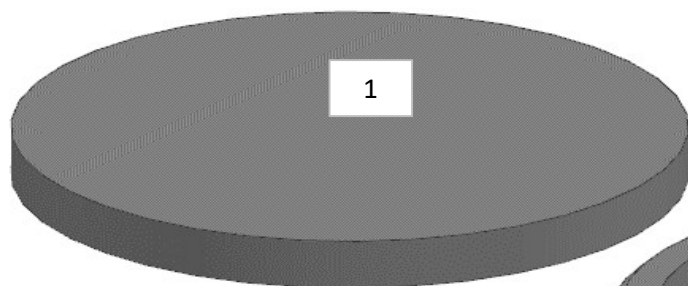

**ELEMENTO DA MONTARE:  
MG\_VQ01  
e spedire con un unico imballo**

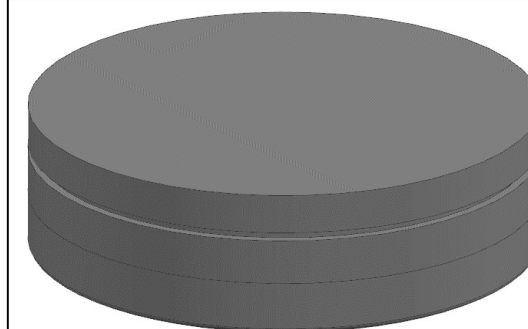

**CAPRI:** GIALLO- RAL 1004 100 gloss  
**RIVIERA:** ACQUAMARINA - NCS S2030-B50G 100 gloss  
**NEUTRO** - LACCATO BRONZO DA CAMPIONE

**consonni&c**