

AZ26M

REV. 01-2023

REV. GR 9

LOCALE	CODICE	DESCRIZIONE COMPONENTE	FINITURA	Q.TA	OPERATORE
CABINA MARINAIO	AZ26M-L01_MF01	ARMADIO MARINAIO	LACCATO BIANCO 9016	3	Dante

- 1 - L.68 x H 1701 x 32
- 2 - L.409 x H 1002 x sp 16
- 3 - L.409 x H 696 x sp 16

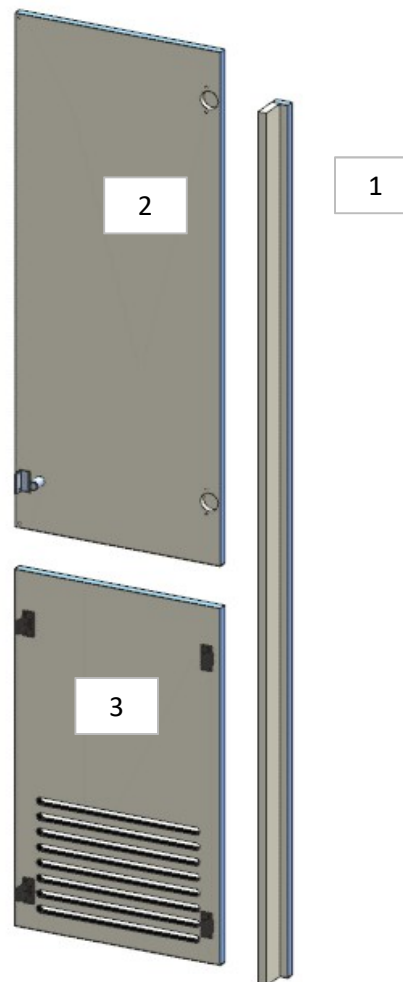

AZ26M

REV. 01-2023

REV. GR 9

LOCALE	CODICE	DESCRIZIONE COMPONENTE	FINITURA	Q.TA	OPERATORE
CABINA MARINAIO	AZ26M-L01_MG01	PLENUM MARINAIO	LACCATO BIANCO 9016	1	Dante

1 - L 443 x H.146 x sp 17

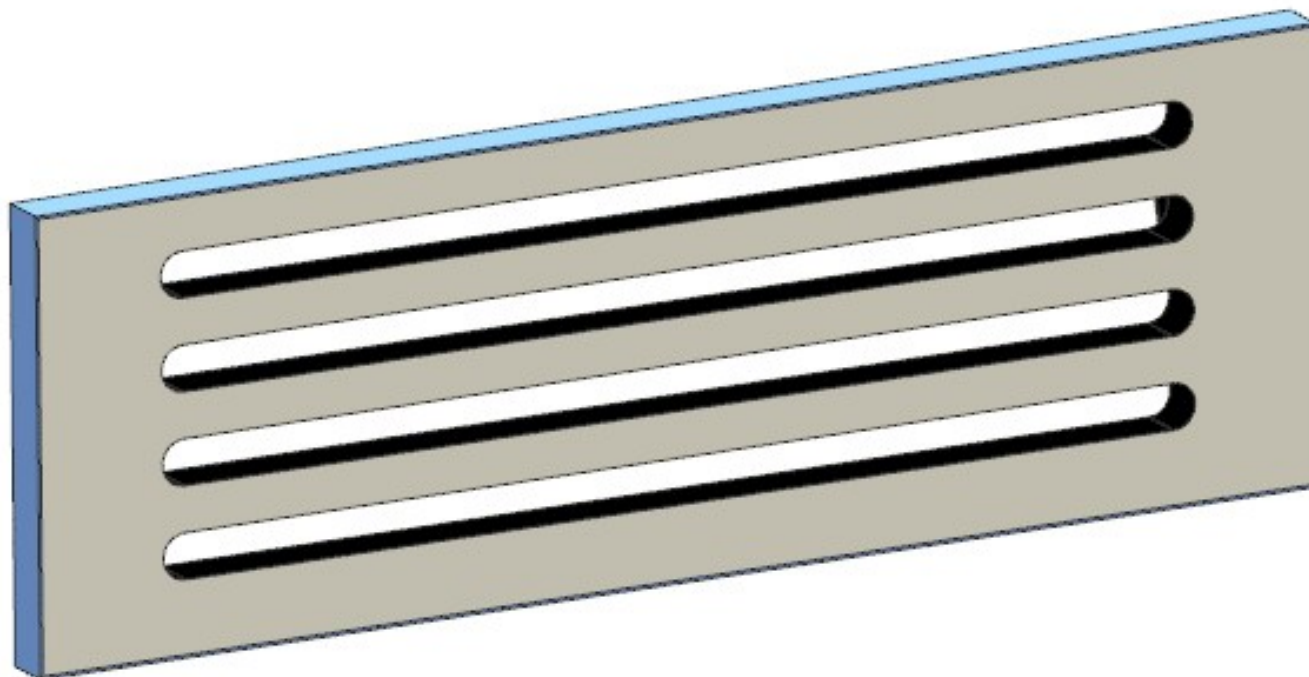

AZ26M

REV. GR 9

LOCALE	CODICE	DESCRIZIONE COMPONENTE	FINITURA	Q.TA	OPERATORE
CABINA MARINAIO	AZ26M-L01_ML01	PENSILE MURATA COMANDANTE	LACCATO BIANCO 9016	2	Dante

1 - 2 - L 477 x H.542 x sp 16

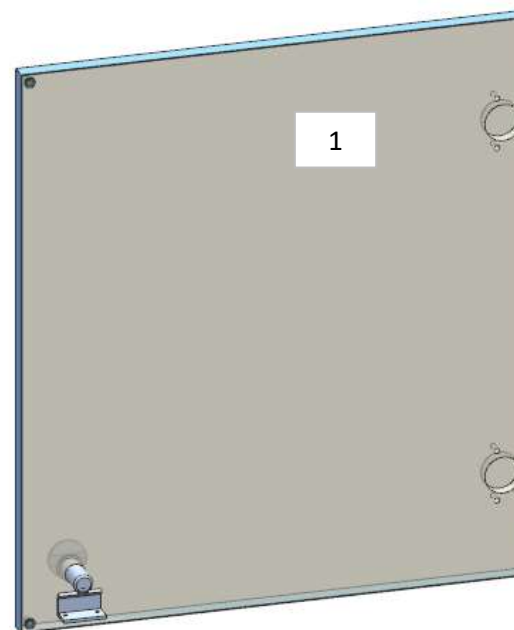
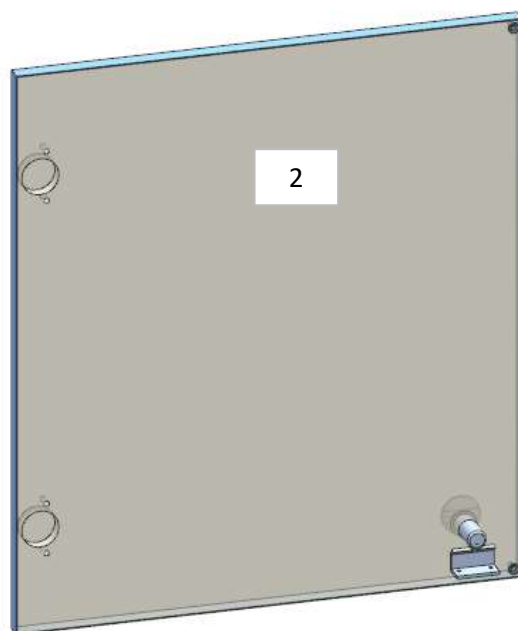

AZ26M

REV. 01-2023

REV. GR 9

LOCALE	CODICE	DESCRIZIONE COMPONENTE	FINITURA	Q.TA	OPERATORE
CABINA MARINAIO	AZ26M-L01_MN01	ARMADIO COMANDANTE	LACCATO BIANCO 9016	1	Dante

1 - L.435 x H.1319 x sp 16



AZ26M

REV. 01-2023

REV. GR 9

LOCALE	CODICE	DESCRIZIONE COMPONENTE	FINITURA	Q.TA	OPERATORE
CABINA MARINAIO	AZ26M-L01_MO01	PENSILE DINETTE	LACCATO BIANCO 9016	4	Dante

1 - 2 - 3 - 4 - L.364 x H.569 x sp 16

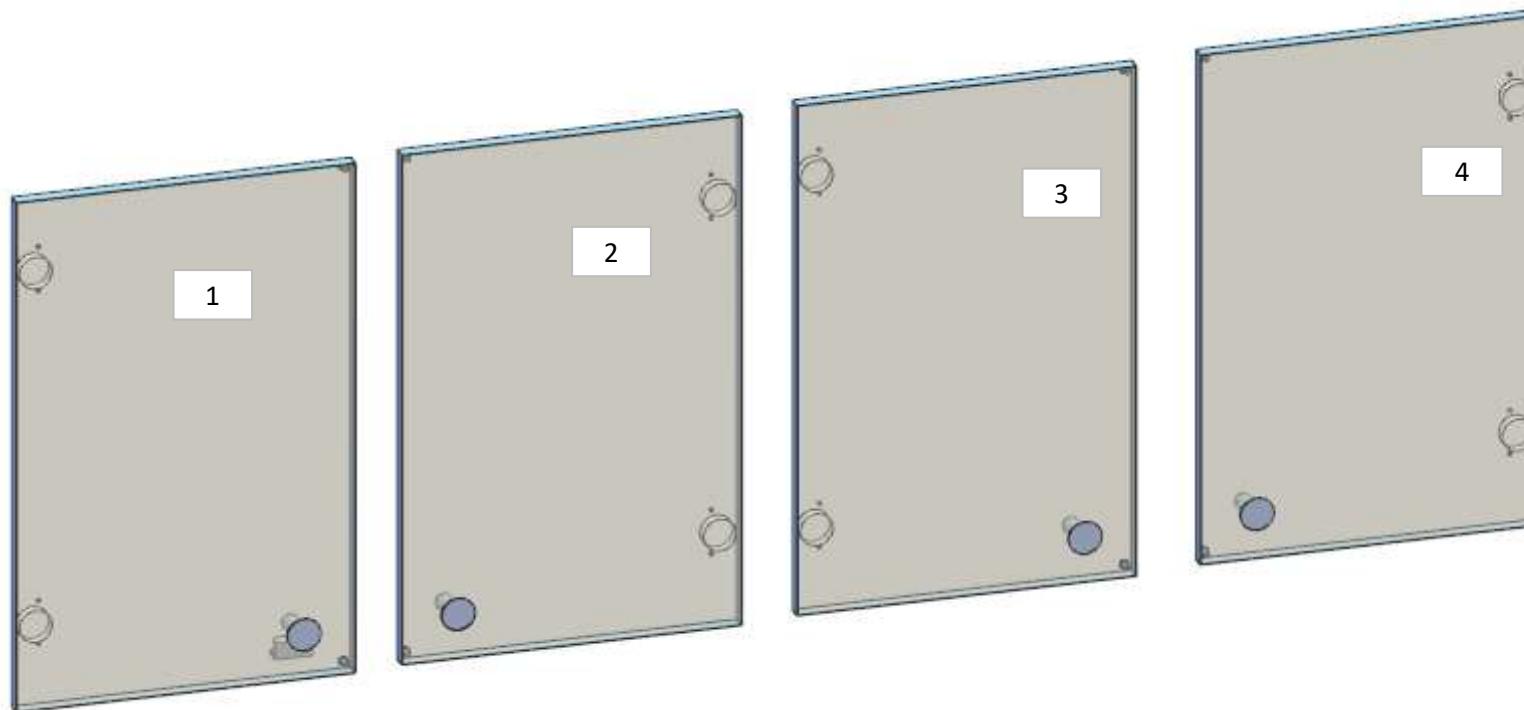

AZ26M

REV. 01-2023

REV. GR 9

LOCALE	CODICE	DESCRIZIONE COMPONENTE	FINITURA	Q.TA	OPERATORE
CABINA MARINAIO	AZ26M-L01_MS01	MOBILE LAVATRICE SX	LACCATO BIANCO 9016	1	Dante

1 - L.151 x H 911 x sp 16



AZ26M

REV. 01-2023

REV. GR 9

LOCALE	CODICE	DESCRIZIONE COMPONENTE	FINITURA	Q.TA	OPERATORE
CABINA MARINAIO	AZ26M-L01_MT01	MOBILE LAVATRICE DX	LACCATO BIANCO 9016	1	Dante

1 - L.151 x H 911 x sp 16



AZ26M

REV. 01-2023

REV. GR 9

LOCALE	CODICE	DESCRIZIONE COMPONENTE	FINITURA	Q.TA	OPERATORE
CABINA MARINAIO	AZ26M-L01_MU01	PENSILE LAVATRICE SX	LACCATO BIANCO 9016	1	Dante

1 - L.782 x H 322 x sp 16

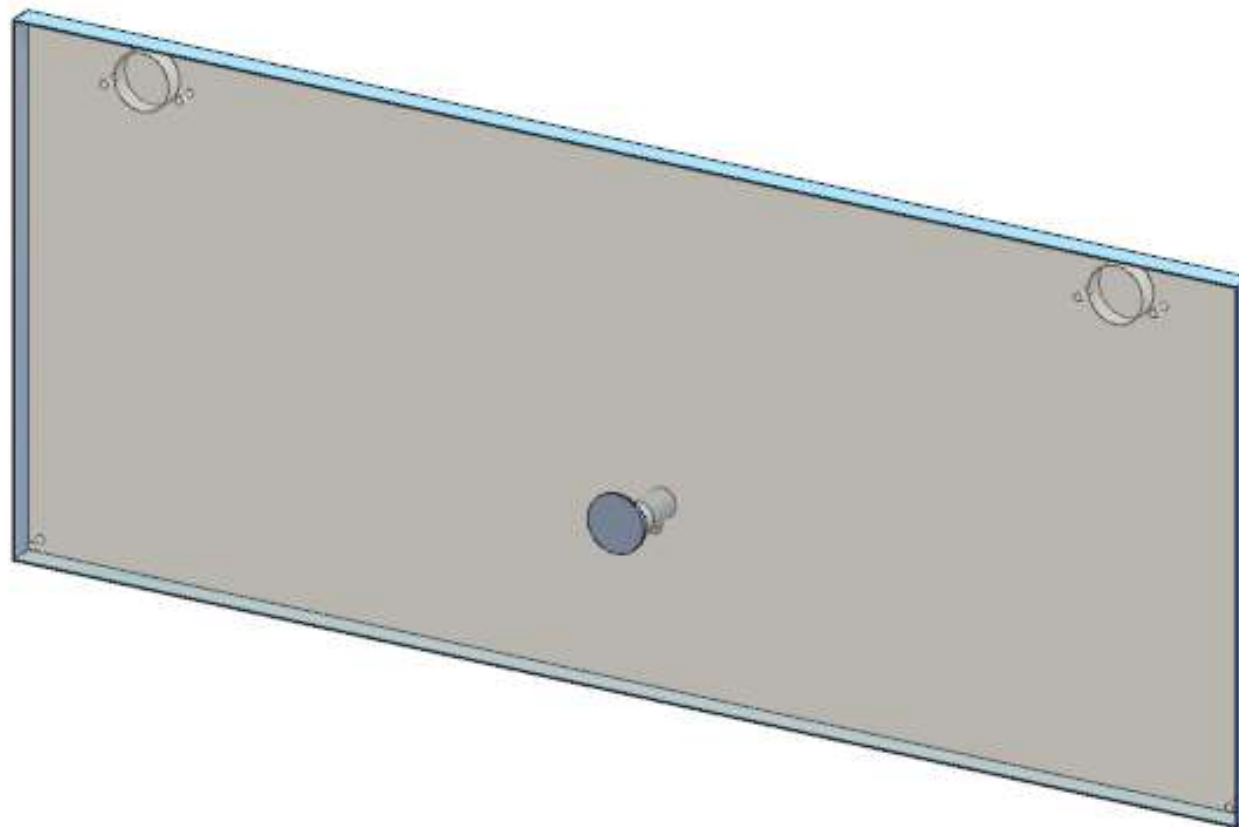

AZ26M

REV. 01-2023

REV. GR 9

LOCALE	CODICE	DESCRIZIONE COMPONENTE	FINITURA	Q.TA	OPERATORE
CABINA MARINAIO	AZ26M-L01_MV01	PENSILE LAVATRICE DX	LACCATO BIANCO 9016	1	Dante

1 - L.782 x H.322 x sp 16

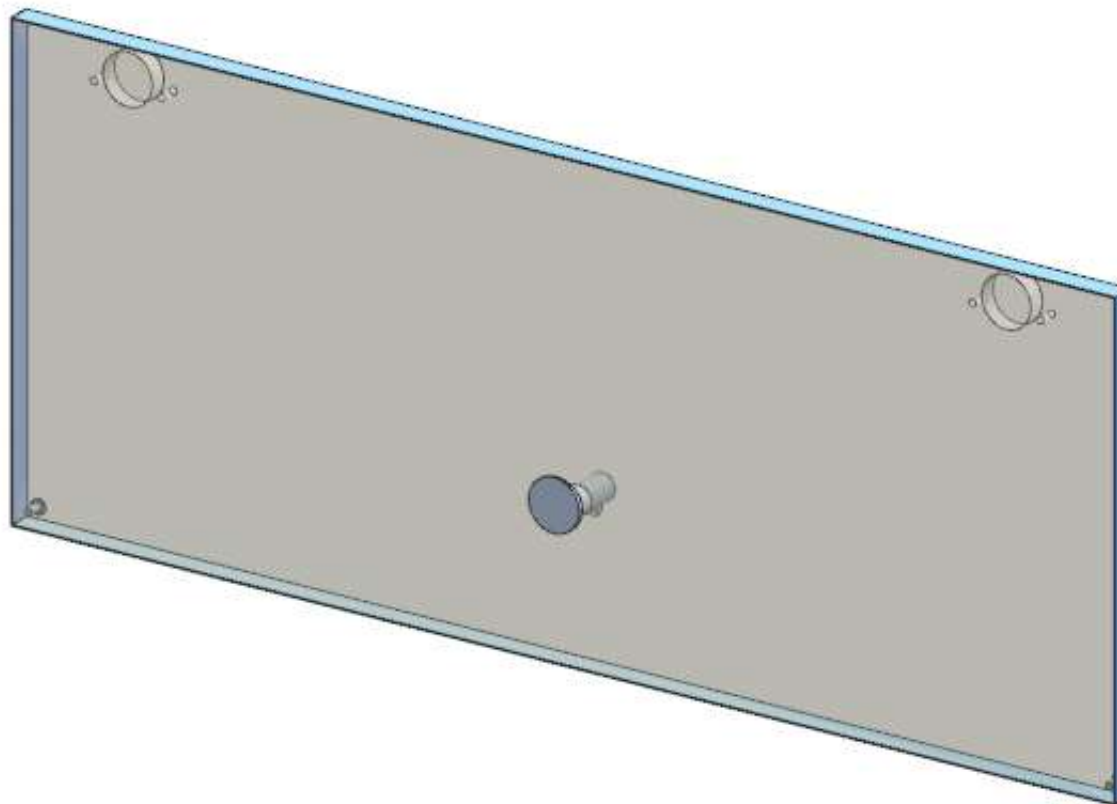

AZ26M

REV. 01-2023

REV. GR 9

LOCALE	CODICE	DESCRIZIONE COMPONENTE	FINITURA	Q.TA	OPERATORE
CABINA MARINAIO	AZ26M-L01_MY01	MOBILE LAVATRICE DX OPT	LACCATO BIANCO 9016	2	Dante

1 - 2 - L.315 x H 911 x sp 16

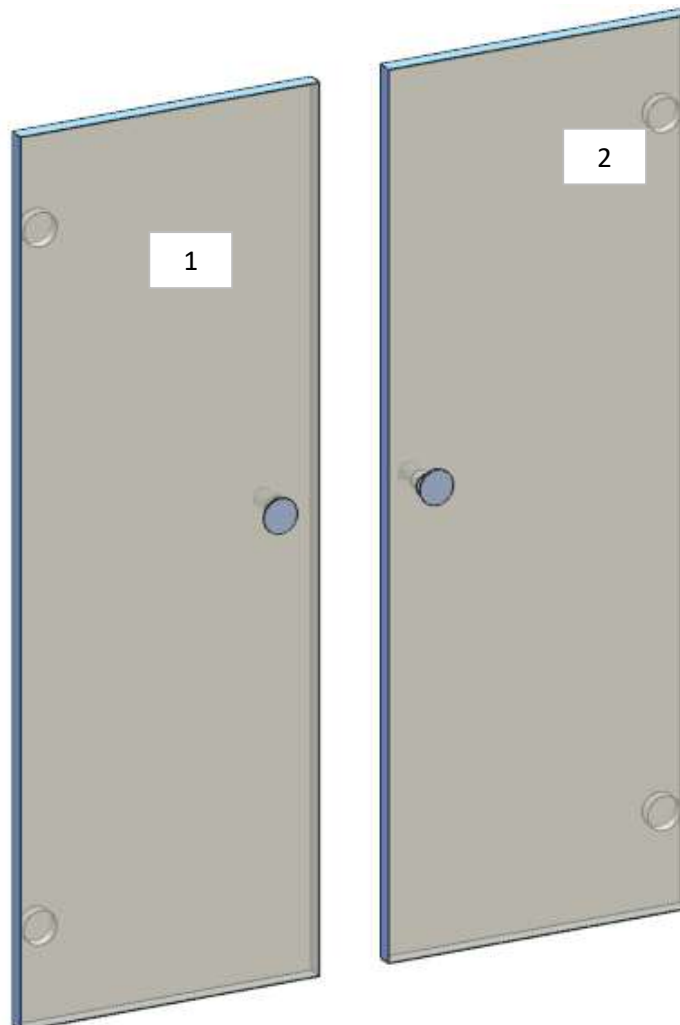

AZ26M

REV. GR 9

LOCALE	CODICE	DESCRIZIONE COMPONENTE	FINITURA	Q.TA	OPERATORE
CABINA MARINAIO	AZ26M-L01_MMG01	CIELINO DINETTE SX	LACCATO BIANCO 9016	2	Damiano

- 1 - L.924 x H.466 x sp 16
- 2 - L 1651 x H 701 x sp 16

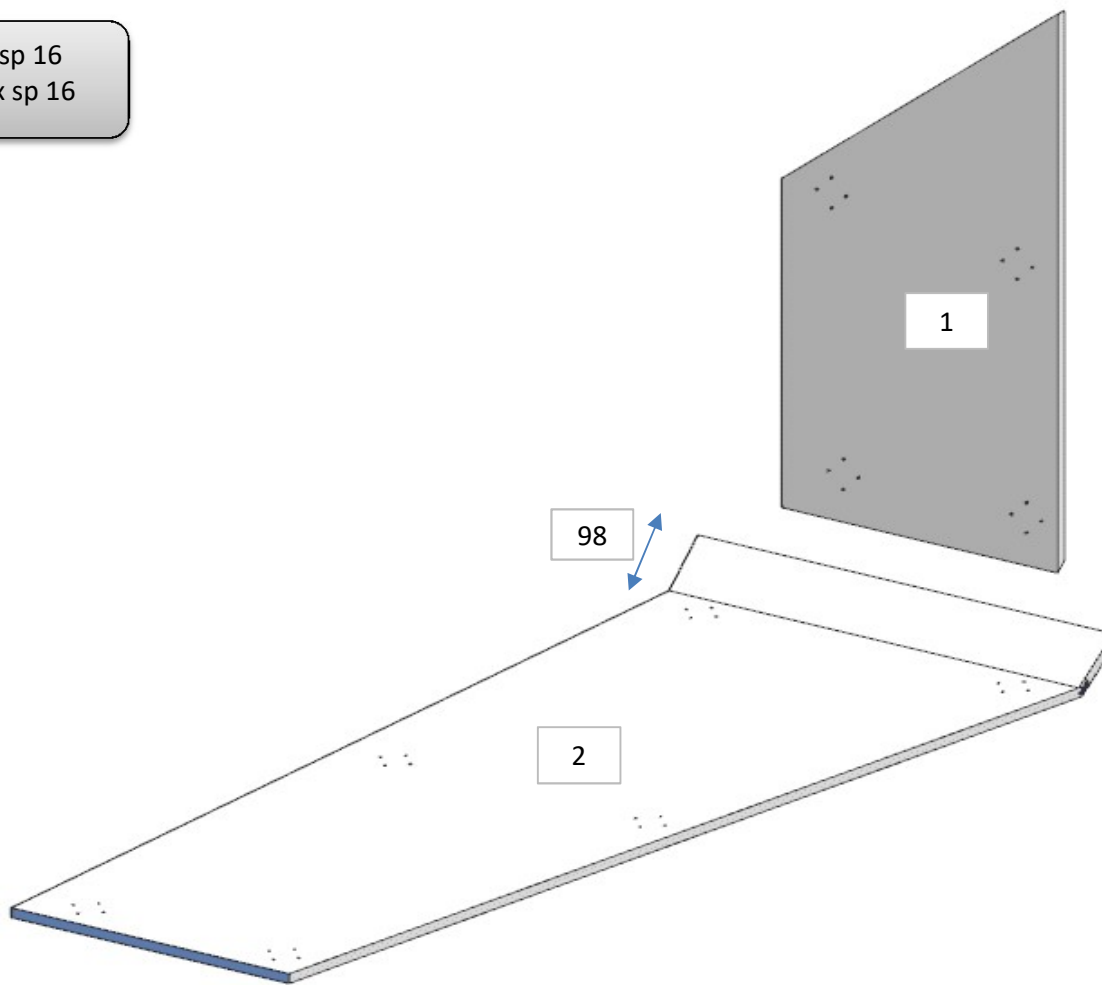

AZ26M

REV. GR 9

LOCALE	CODICE	DESCRIZIONE COMPONENTE	FINITURA	Q.TA	OPERATORE
CABINA MARINAIO	AZ26M-L01_MMH01	CIELINO ALZATA DINETTE SX	LACCATO BIANCO 9016	1	Damiano

1 - L 1645 x H 395 x sp 16

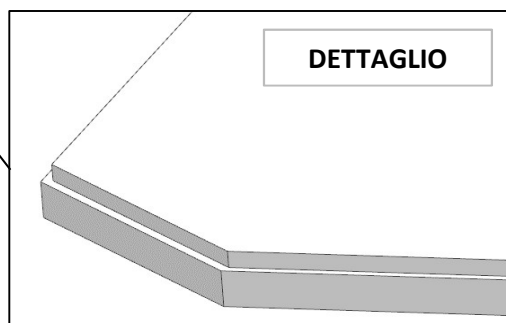
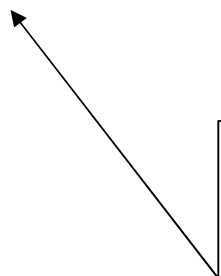
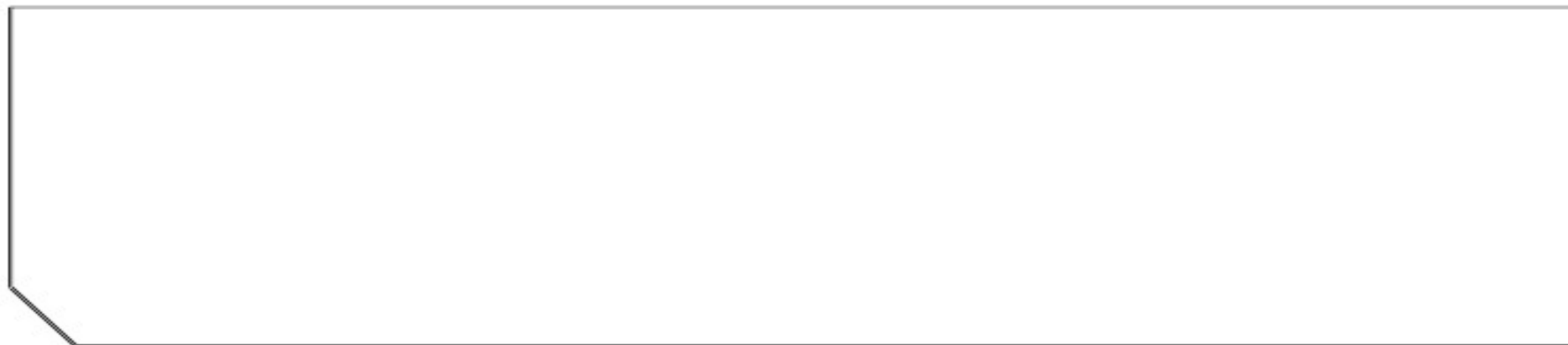

AZ26M

REV. GR 9

LOCALE	CODICE	DESCRIZIONE COMPONENTE	FINITURA	Q.TA	OPERATORE
CABINA MARINAIO	AZ26M-L01_MMI01	CIELINO ALZATA DINETTE DX	LACCATO BIANCO 9016	2	Damiano

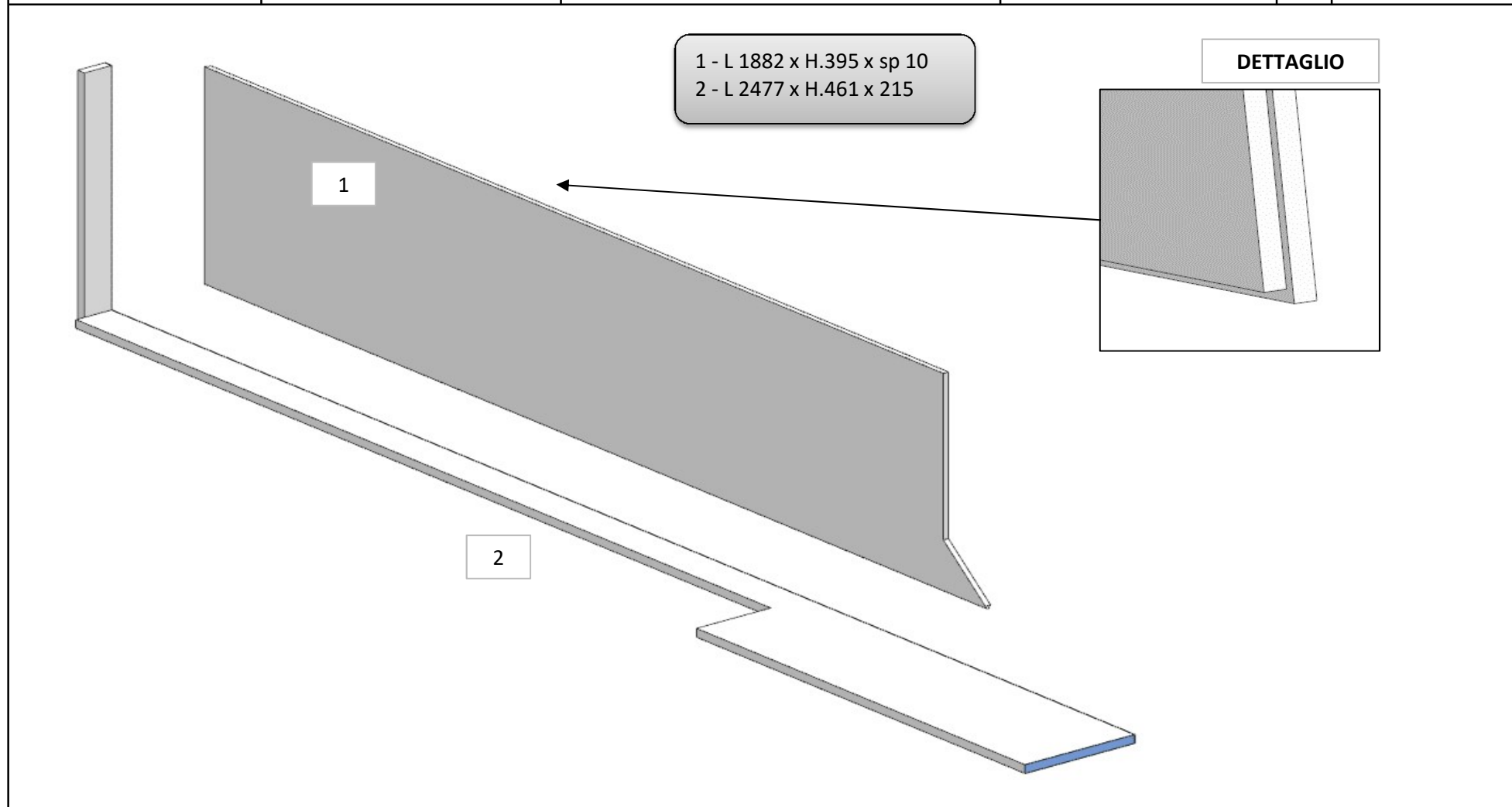

AZ26M

REV. GR 9

LOCALE	CODICE	DESCRIZIONE COMPONENTE	FINITURA	Q.TA	OPERATORE
CABINA MARINAIO	AZ26M-I01_MMJ01	CIELINO DINETTE CENTRO BARCA	GREZZO OKUME'	1	Dante

1 - L.1245 x H 492 x sp 10

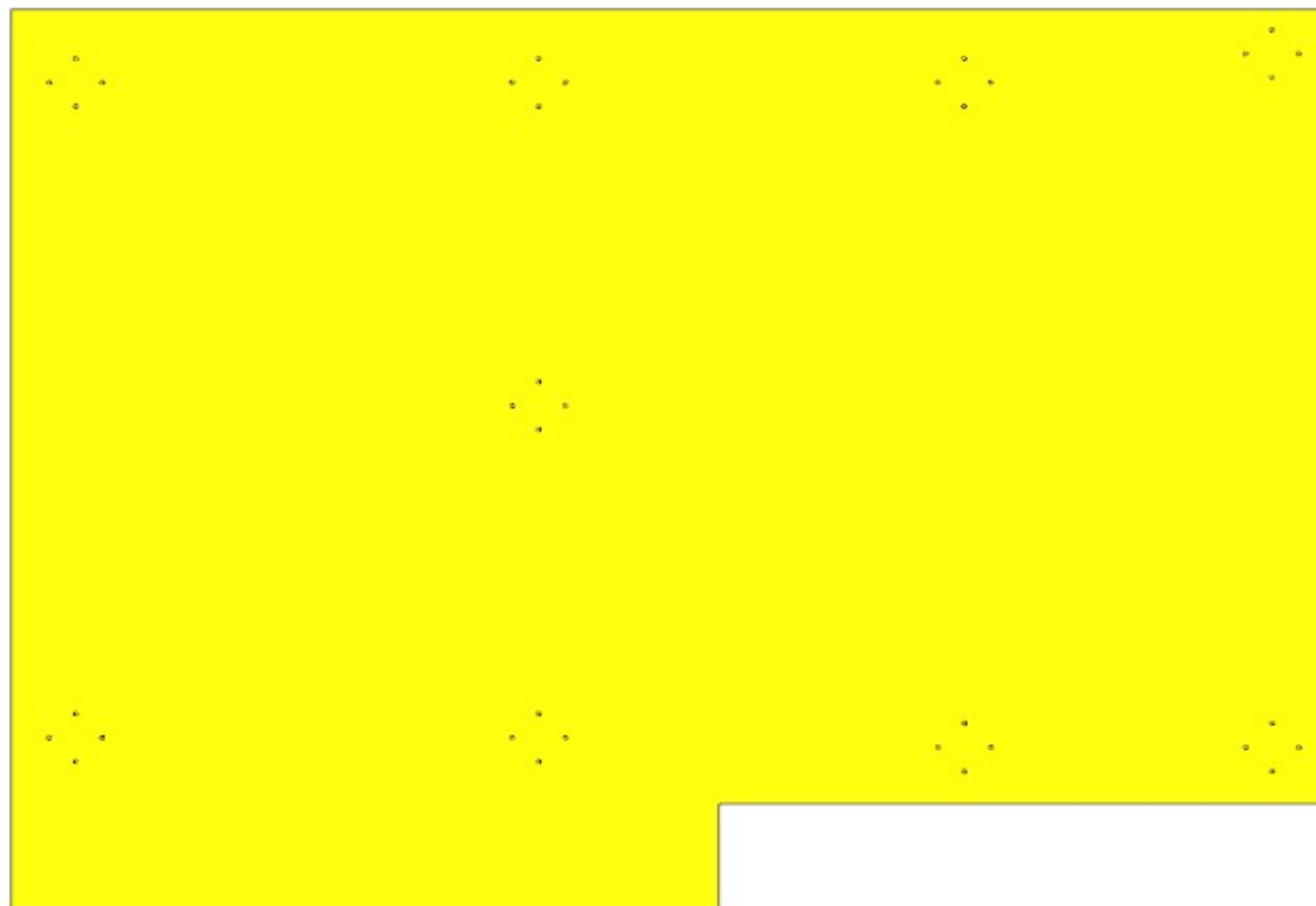

consonni&c

AZ26M

REV. GR 9

LOCALE	CODICE	DESCRIZIONE COMPONENTE	FINITURA	Q.TA	OPERATORE
CABINA MARINAIO	AZ26M-L01_MMM01	CIELINO BAGNO MARINAIO	LACCATO BIANCO 9016	1	Damiano

1 - L.741 x H 526 x sp 10

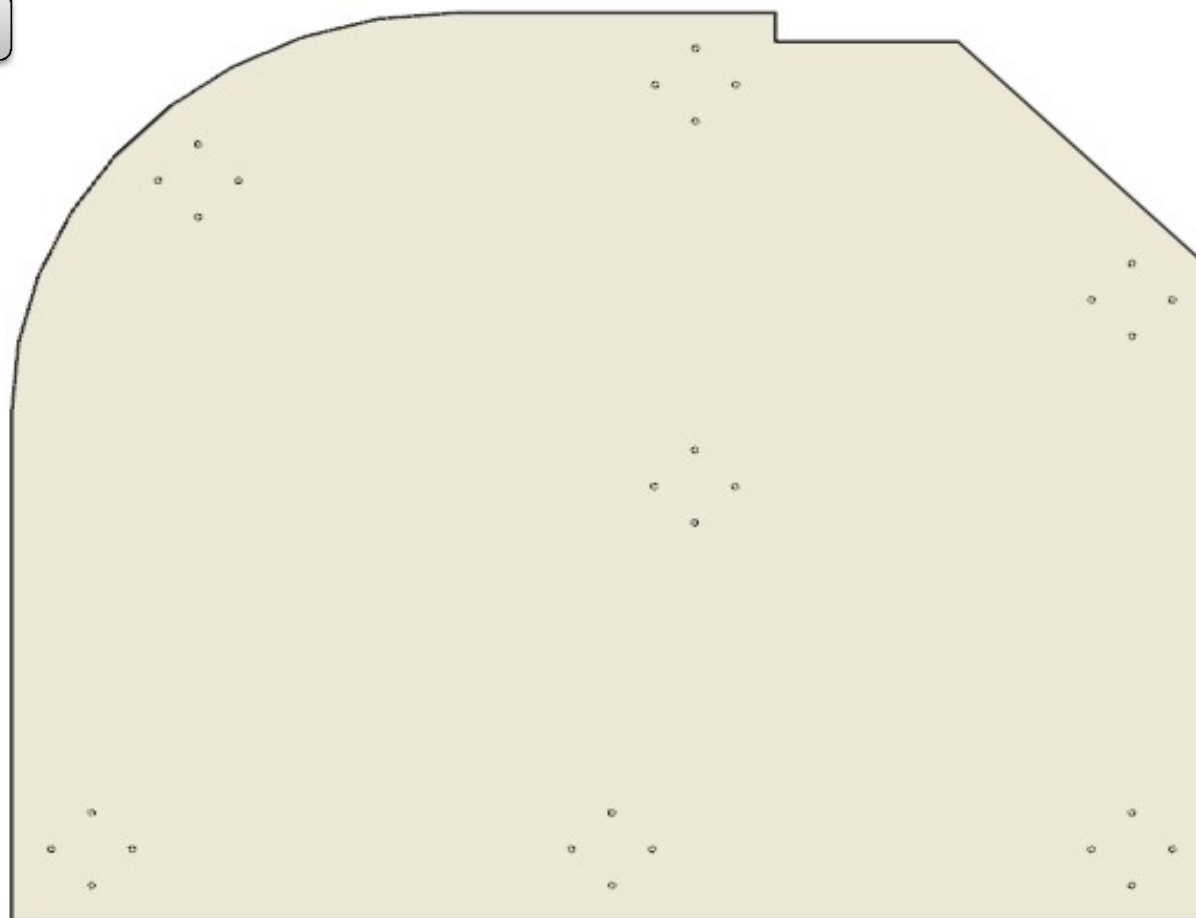

AZ26M

REV. 01-2023

REV. GR 9

LOCALE	CODICE	DESCRIZIONE COMPONENTE	FINITURA	Q.TA	OPERATORE
CABINA MARINAIO	AZ26M-X02_MMN01_01	MOBILE LAVELLO BAGNO MARINAIO	GENTAS	3	Dante

- 1 - L 1034 x H.363 x sp 12
- 2 - L 522 x H.360 x sp 12
- 3 - L 417 x H.52 x 265

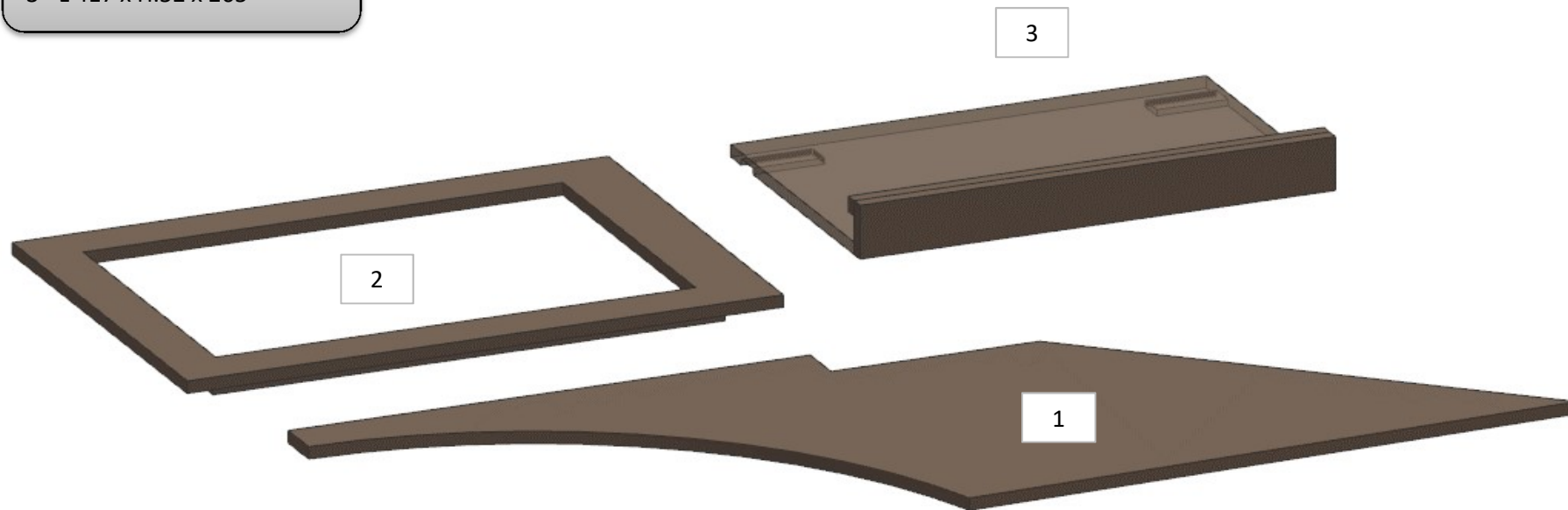

AZ26M

REV. 01-2023

REV. GR 9

LOCALE	CODICE	DESCRIZIONE COMPONENTE	FINITURA	Q.TA	OPERATORE
CABINA MARINAIO	AZ26M-L01_MMN01	MOBILE LAVELLO BAGNO MARINAIO	LACCATO BIANCO 9016	2	Damiano

1 - 2 - L.232 x H.397 x sp 16

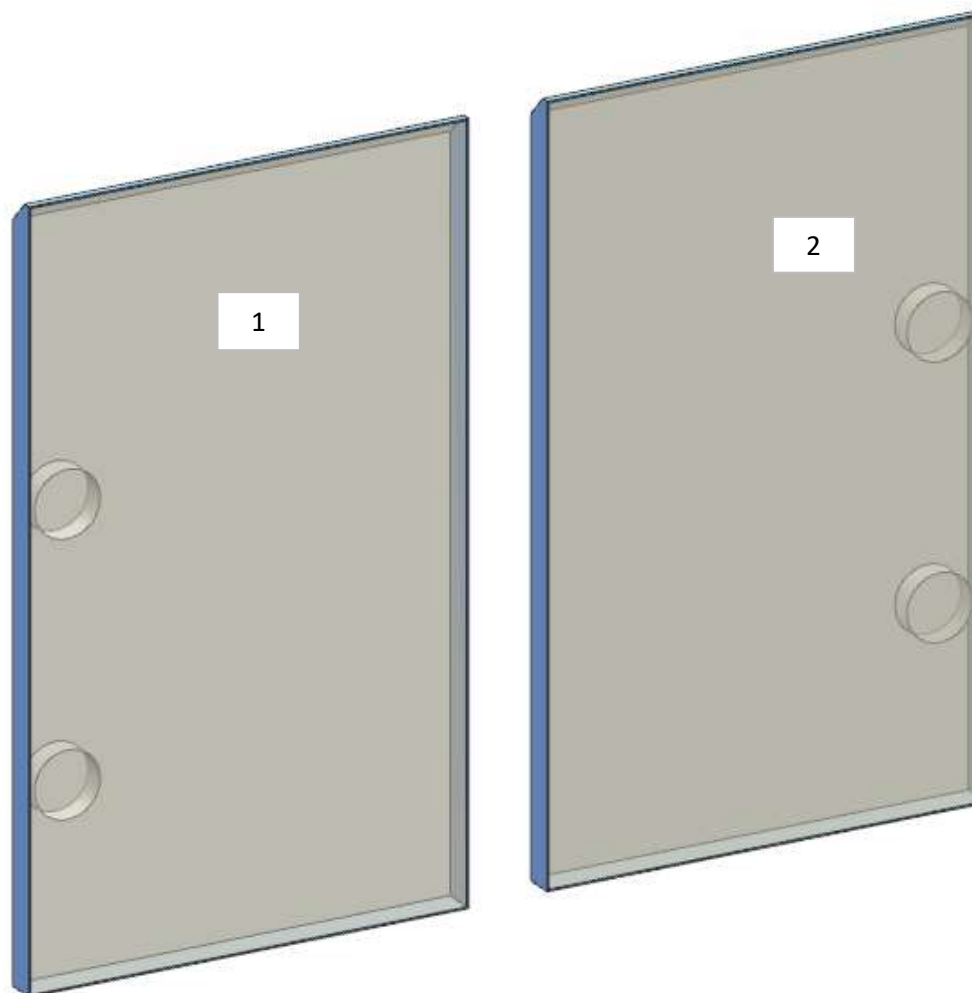

AZ26M

REV. GR 9

LOCALE	CODICE	DESCRIZIONE COMPONENTE	FINITURA	Q.TA	OPERATORE
CABINA MARINAIO	AZ26M-X01_MMO01	RIVESTIMENTI BAGNO MARINAIO	LAMINATO CLEAF SABLE'	4	Dante

- 1 - L.1169 x H.1956 x sp 10
- 2 - L.705 x H.1956 x sp 10
- 3 - L.446 x H.411 x sp 32
- 4 - L.1428 x H.322 x sp 11

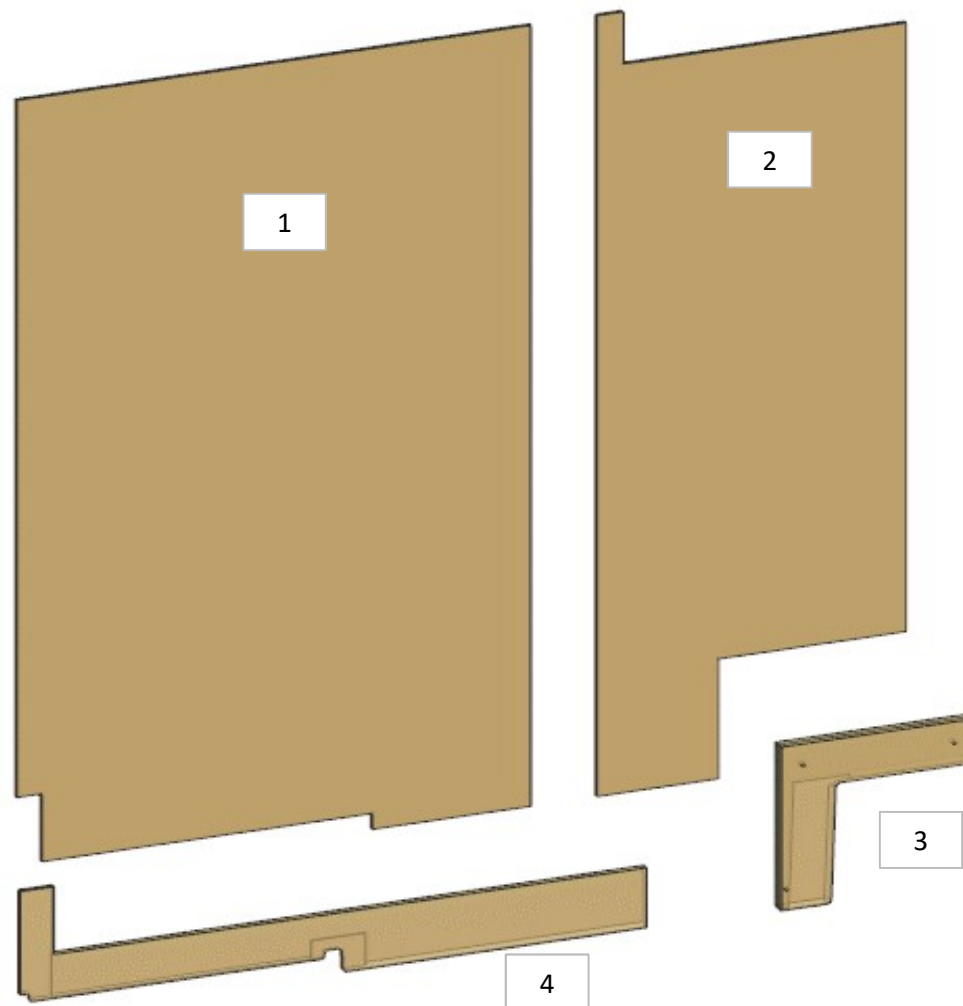

AZ26M

REV. GR 9

LOCALE	CODICE	DESCRIZIONE COMPONENTE	FINITURA	Q.TA	OPERATORE
CABINA MARINAIO	AZ26M-X01_MMS01	CARABOTTINO BAGNO MARINAIO	LAMINATO GENTAS	2	Damiano

1 - L.235 x H 557 x sp 12
2 - L.434 x H 557 x sp 12

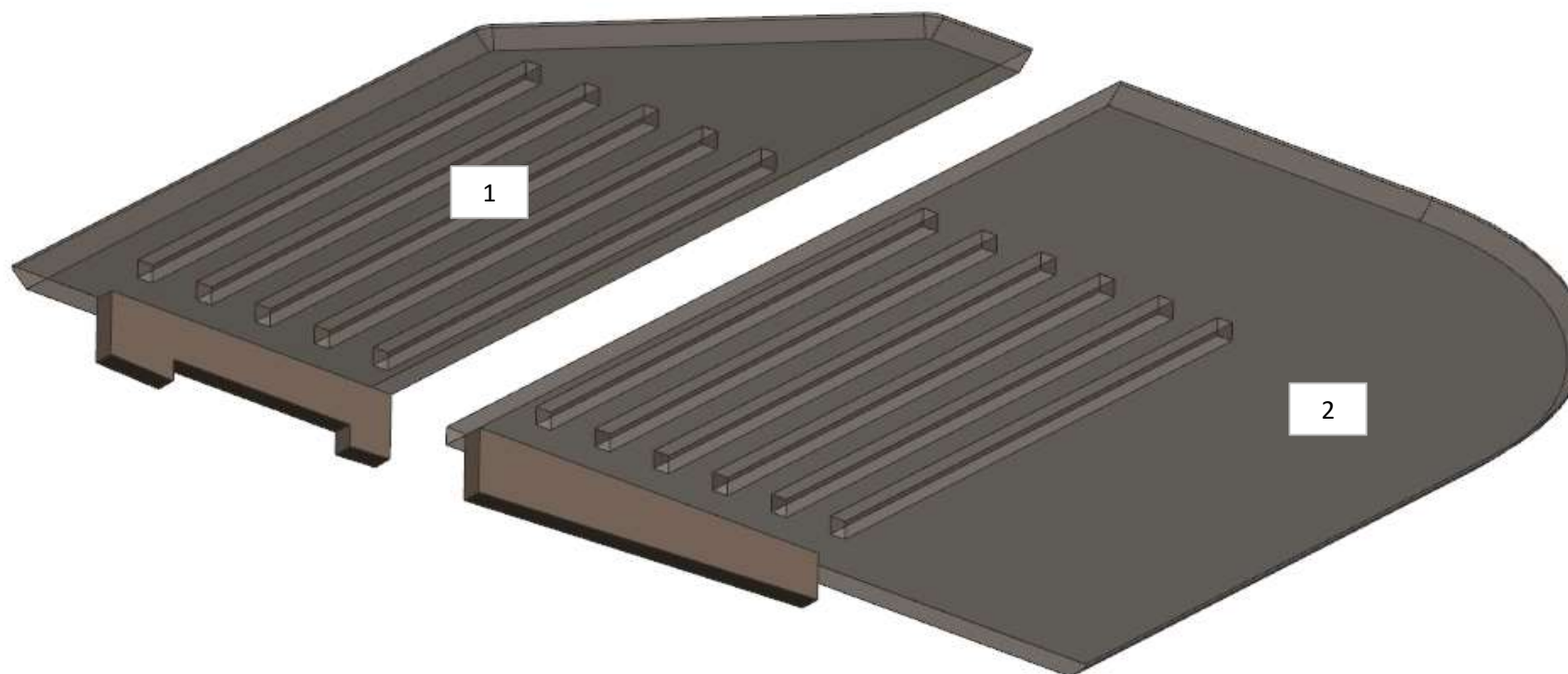

AZ26M

REV. GR 9

LOCALE	CODICE	DESCRIZIONE COMPONENTE	FINITURA	Q.TA	OPERATORE
CABINA MARINAIO	AZ26M-X01_MMT01	PAVIMENTO BAGNO MARINAIO	LAMINATO MARINAIO OLMO FUME'	4	Damiano

- 1 - L.484 x H 569 x sp 12
- 2 - L.405 x H 1122 x sp 12
- 3 - L.438 x H 339 x sp 12
- 4 - L.836 x H 540 x sp 12

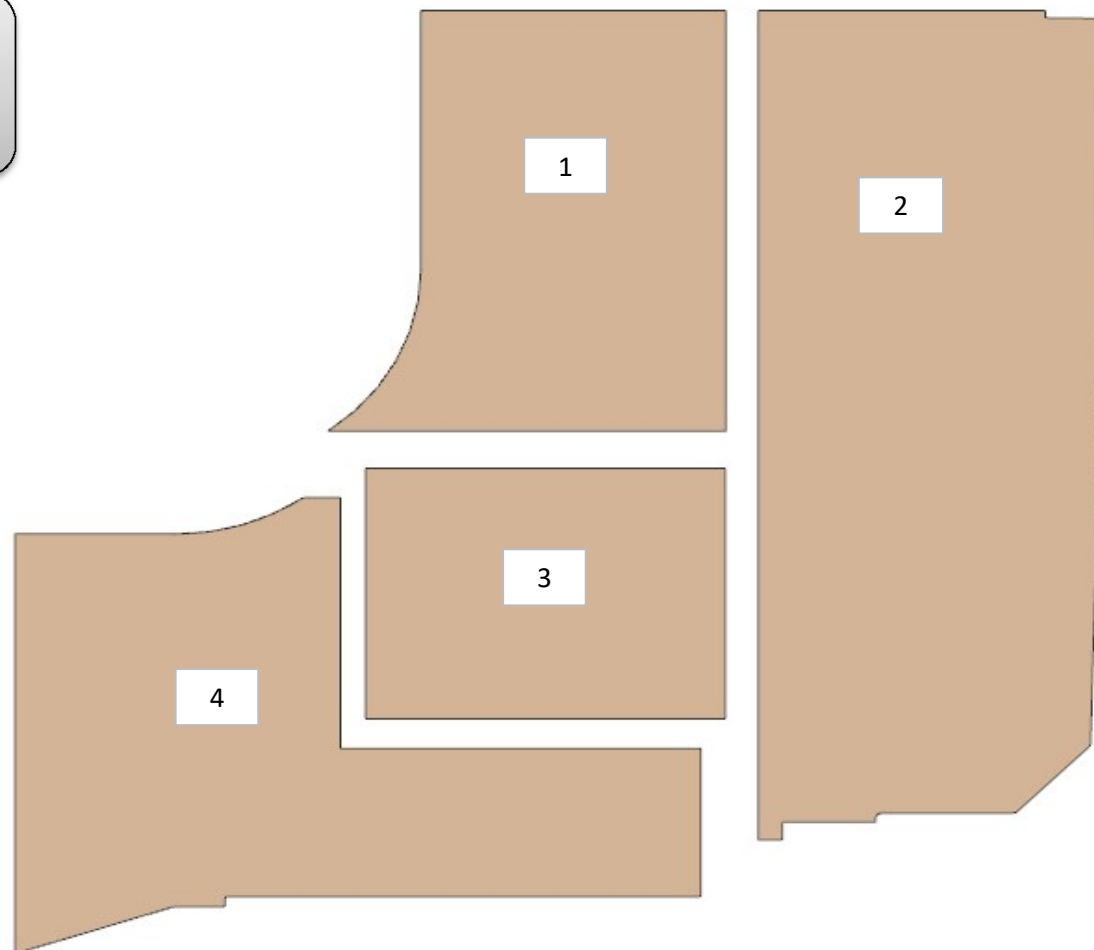

AZ26M

REV. GR 9

LOCALE	CODICE	DESCRIZIONE COMPONENTE	FINITURA	Q.TA	OPERATORE
CABINA MARINAIO	AZ26M-L01_MMX01	MENSOLA A RIBALTA COMANDANTE OPT	LACCATO BIANCO RAL 9016	1	Damiano

1 - L 430 x H.340 x sp 16

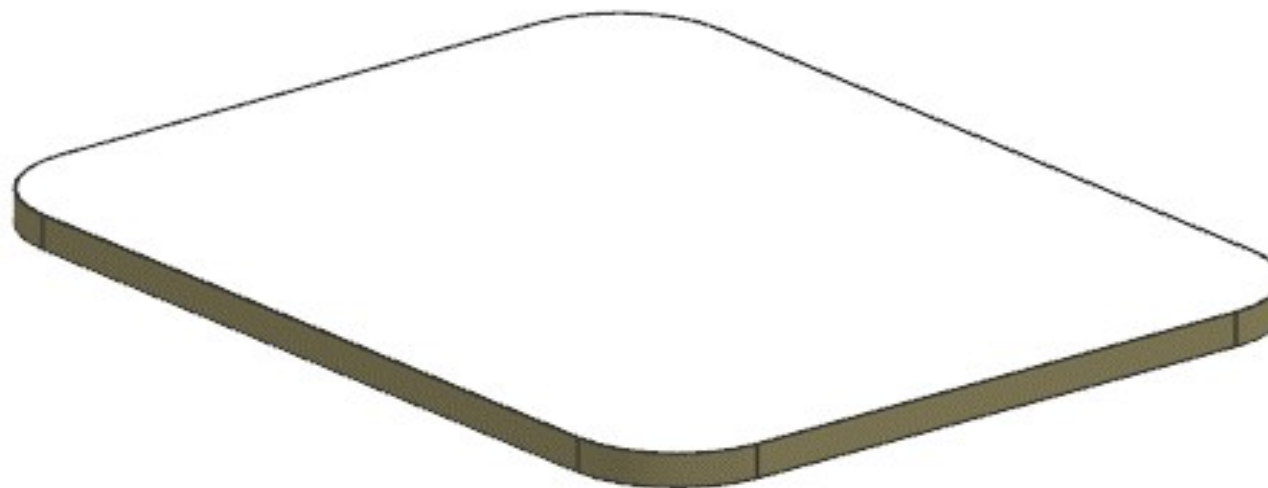

FERRAMENTA:

N° 2 - MECCANISMO A RIBALTA SUGATSUNE

AZ26M

REV. GR 9

LOCALE	CODICE	DESCRIZIONE COMPONENTE	FINITURA	Q.TA	OPERATORE
CABINA MARINAIO	AZ26M-X01_MMY01	RIV. SOTTO LAVELLO BAGNO MARINAIO	LAMINATO CLEAF SABLE'	3	Dante

- 1 - L 488 x H 322 x sp 16
- 2 - L 1020 x H 300 x sp 16
- 3 - L 178 x H 300 x sp 16

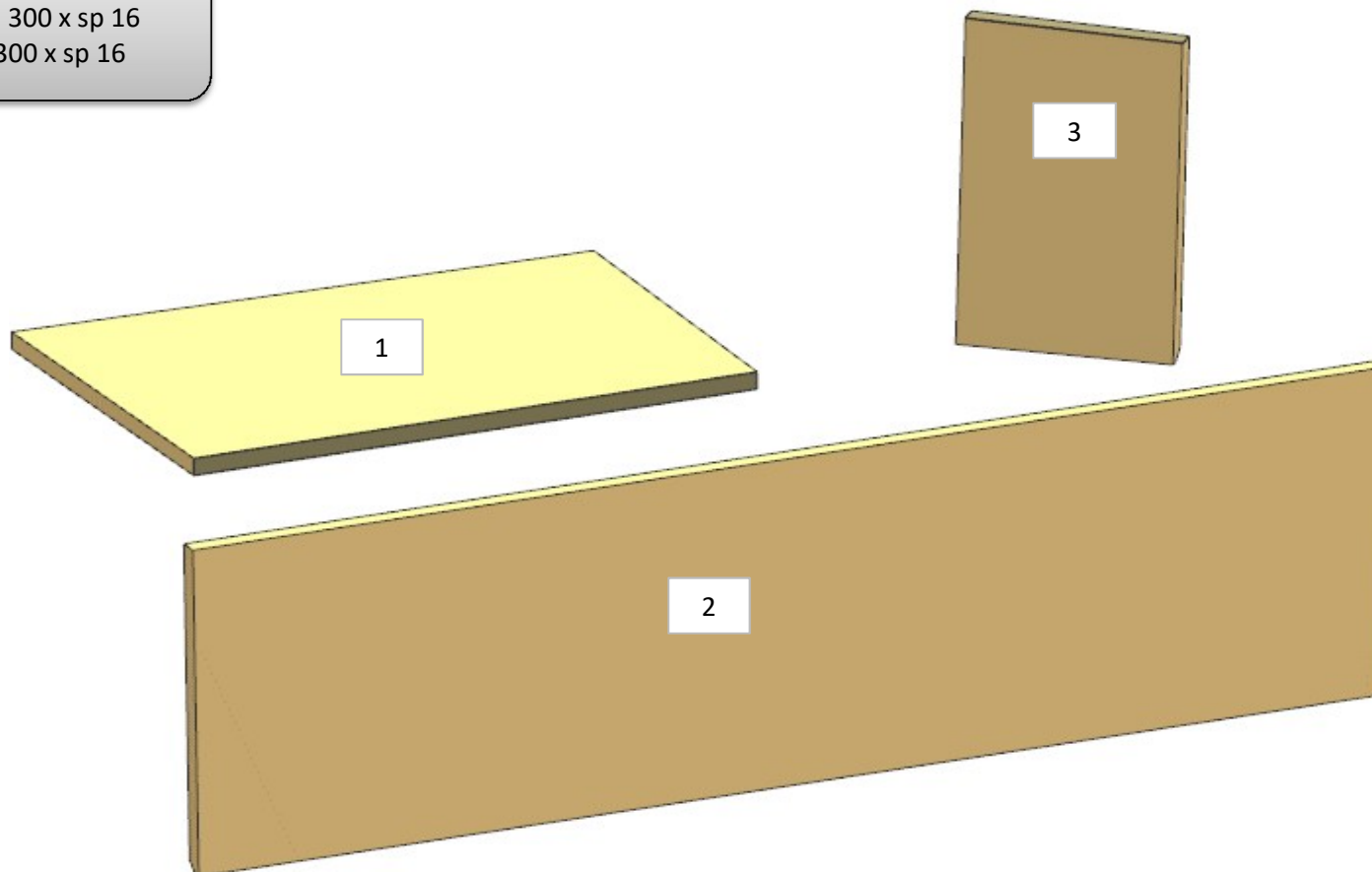

AZ26M

REV. GR 9

LOCALE	CODICE	DESCRIZIONE COMPONENTE	FINITURA	Q.TA	OPERATORE
CABINA MARINAIO	AZ26M-L01_MMZ01	ANTE OPT ARMADIO CAMBUSA	LACCATO BIANCO RAL 9016	5	Damiano

1 - 2 - L 438 x H.348 x sp 16
3 - 4 - L 438 x H.765 x sp 16

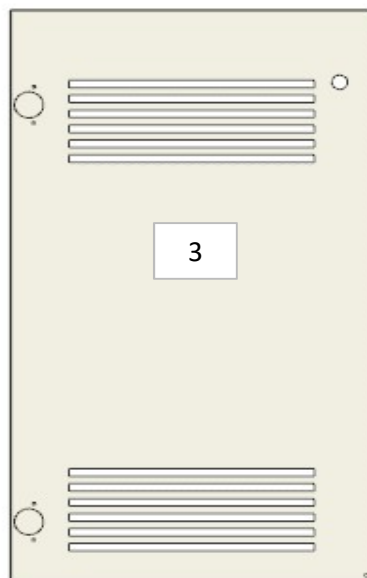

AZ26M

REV. GR 9

LOCALE	CODICE	DESCRIZIONE COMPONENTE	FINITURA	Q.TA	OPERATORE
CABINA MARINAIO	AZ26M-L01_MMZ02	ARMADIO CAMBUSA	LACCATO BIANCO 9016	2	Dante

1 - 2 - L 438 x H.1391 x sp 16

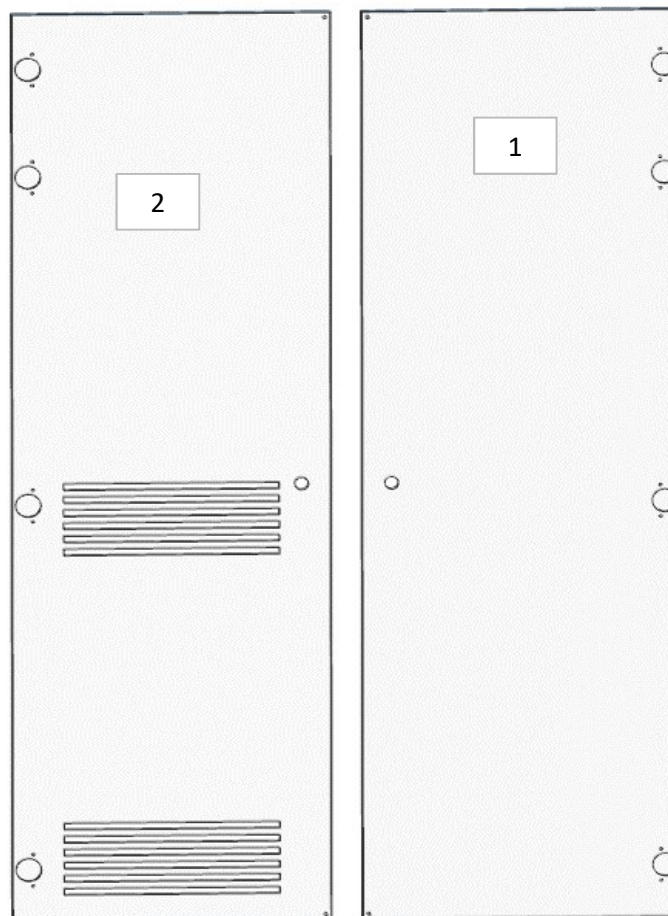

AZ26M

REV. GR 9

LOCALE	CODICE	DESCRIZIONE COMPONENTE	FINITURA	Q.TA	OPERATORE
CABINA MARINAIO	AZ26M-X01_MMMA01	TAVOLO DINETTE MARINAIO	LAMINATO CLEAF SABLE'	1	Damiano

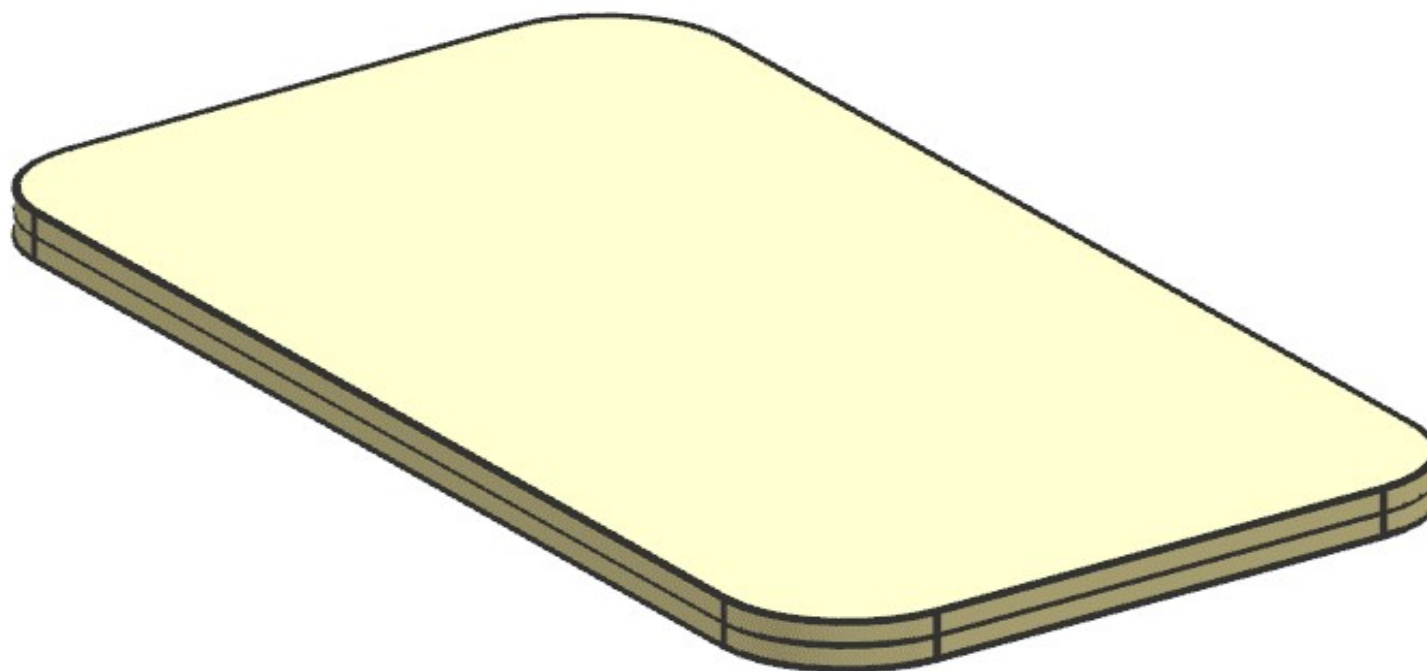

AZ26M

REV. GR 9

LOCALE	CODICE	DESCRIZIONE COMPONENTE	FINITURA	Q.TA	OPERATORE
PORTE MARINAIO	AZ26M-X01_PM1	PORTA BAGNO MARINAIO	LAMINATO CLEAF SABLE ¹	1	Damiano

1 - L 580 x H 1996 x sp 49mm



consonni&c

AZ26M

REV. GR 9

LOCALE	CODICE	DESCRIZIONE COMPONENTE	FINITURA	Q.TA	OPERATORE
PORTE MARINAIO	AZ26M-A01_PM1	PORTA BAGNO MARINAIO	ACCIAIO	2	Damiano

1 - L 479 x H 21 x 65 mm
2 - L 550x H 22 x sp 1 mm

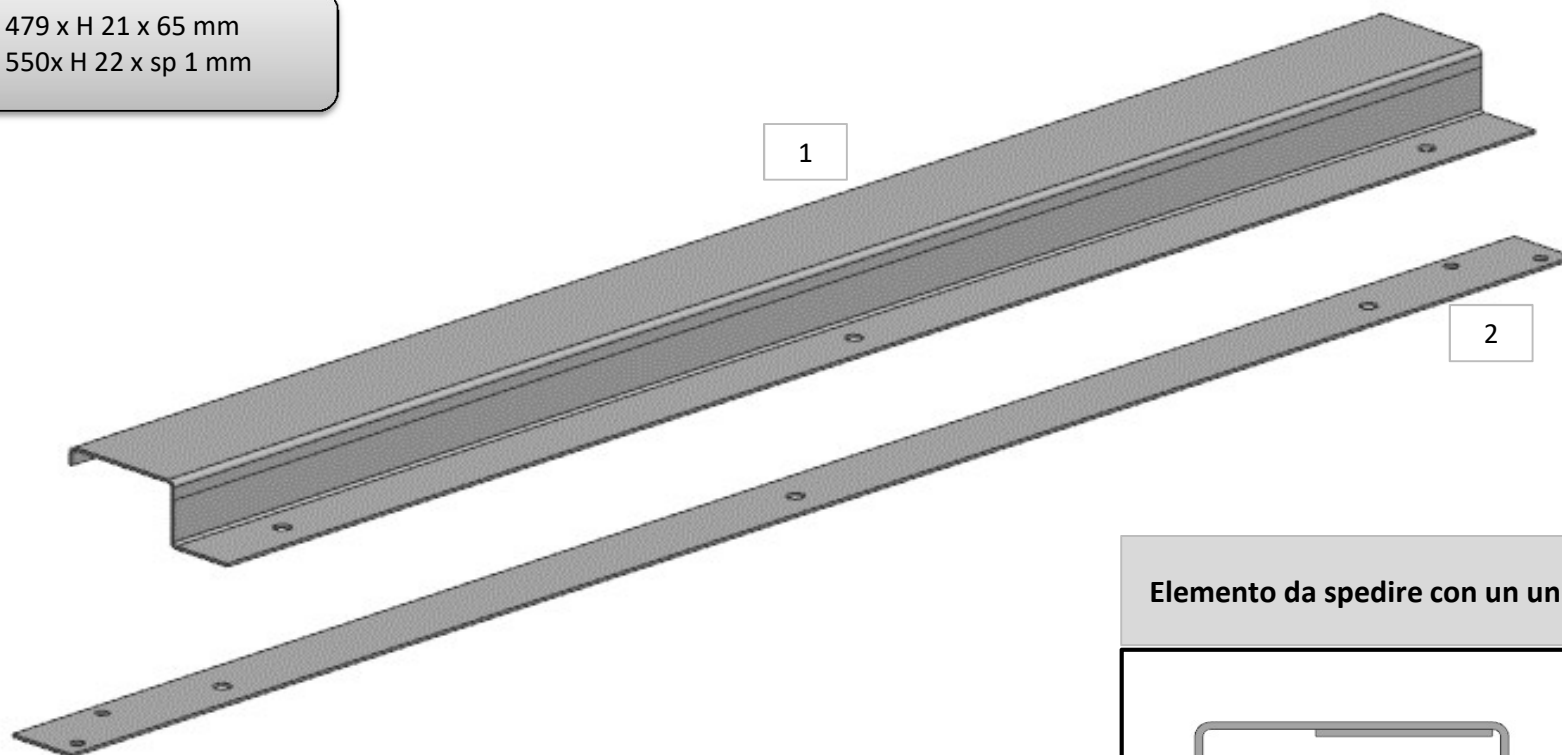

Elemento da spedire con un unico imballo

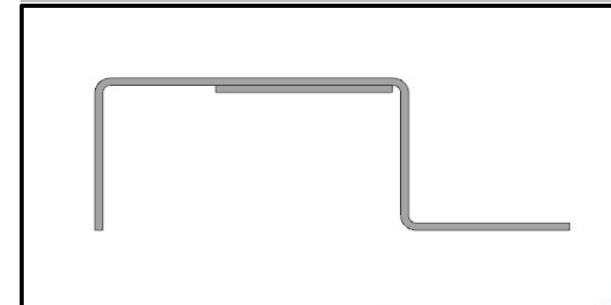

consonni&c

AZ26M

REV. GR 9

LOCALE	CODICE	DESCRIZIONE COMPONENTE	FINITURA	Q.TA	OPERATORE
PORTE MARINAIO	AZ26M-X01_PM2	PORTA CABINA MARINAIO	LAMINATO CLEAF SABLE ¹	1	Damiano

1 - L 605 x H 1996 x sp 49

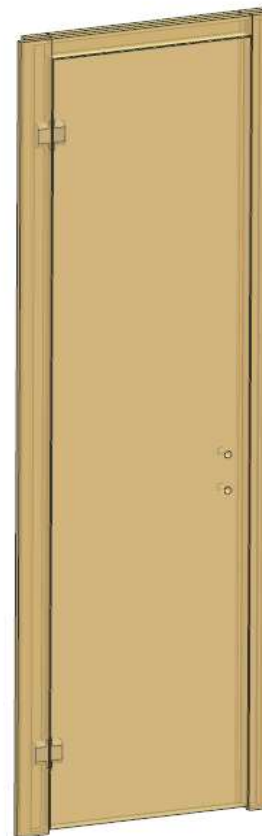

consonni&c

AZ26M

REV. GR 9

LOCALE	CODICE	DESCRIZIONE COMPONENTE	FINITURA	Q.TA	OPERATORE
PORTE MARINAIO	AZ26M-A01_PM2	PORTA CABINA MARINAIO	ACCIAIO	2	Damiano

1 - L 479 x H 21 x 79 mm
2 - L 550x H 22 x sp 1 mm

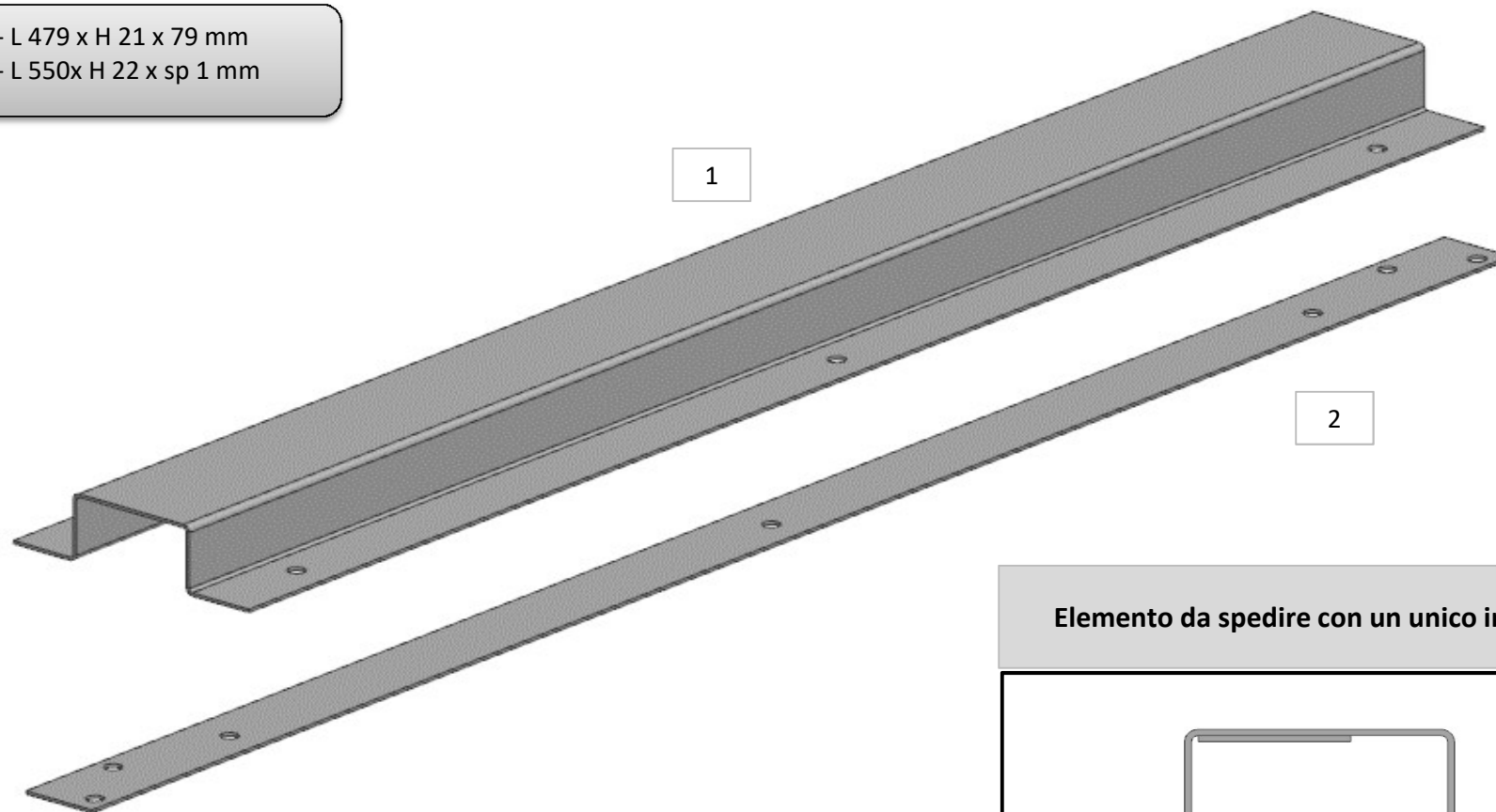

Elemento da spedire con un unico imballo

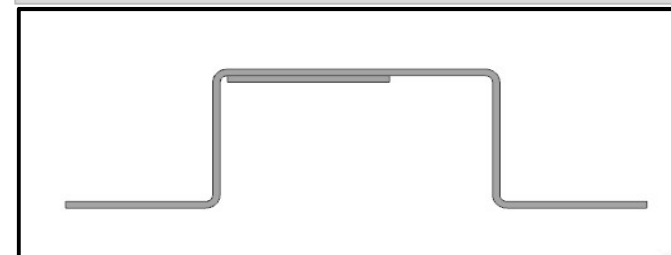

consonni&c

AZ26M

REV. GR 9

LOCALE	CODICE	DESCRIZIONE COMPONENTE	FINITURA	Q.TA	OPERATORE
PORTE MARINAIO	AZ26M-X01_PM3	PORTA CABINA MARINAIO COMANDANTE	LAMINATO CLEAF SABLE ¹	1	Damiano

1 - L 580 x H 1996 x sp 49mm

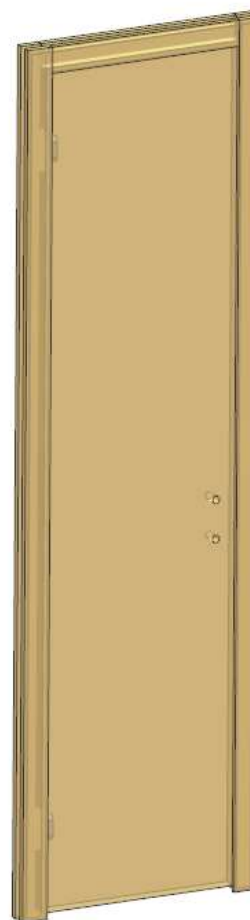

consonni&c

AZ26M

REV. GR 9

LOCALE	CODICE	DESCRIZIONE COMPONENTE	FINITURA	Q.TA	OPERATORE
PORTE MARINAIO	AZ26M-A01_PM3	PORTA CABINA MARINAIO COMANDANTE	ACCIAIO	2	Damiano

1 - L 479 x H 21 x 79 mm
2 - L 550x H 22 x sp 1 mm

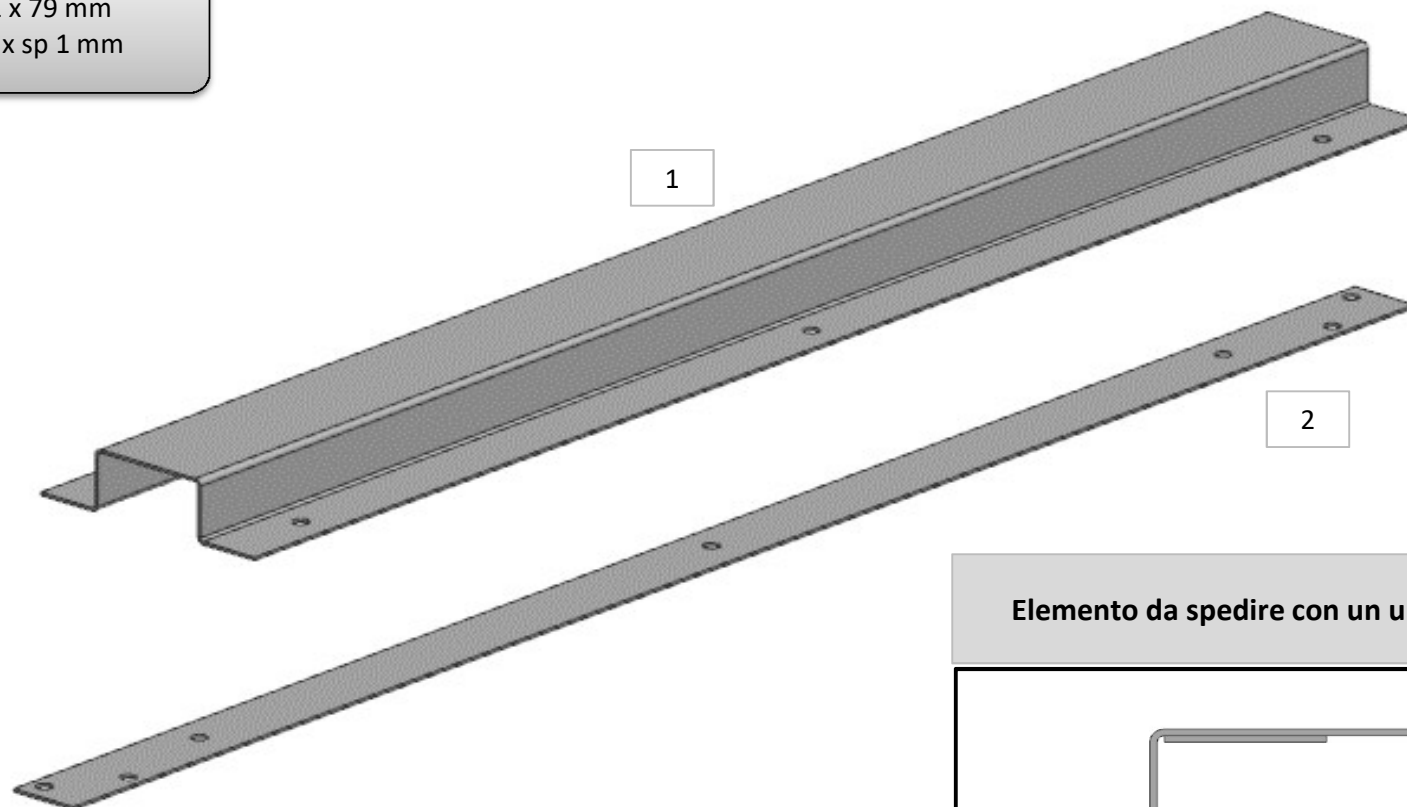

Elemento da spedire con un unico imballo

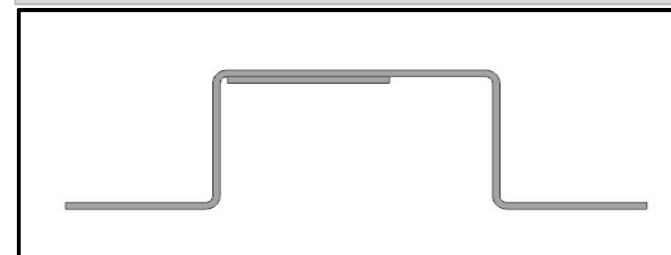

consonni&c

AZ26M

REV. GR 9

LOCALE	CODICE	DESCRIZIONE COMPONENTE	FINITURA	Q.TA	OPERATORE
PORTE MARINAIO	AZ26M-X01_PM17	PORTA CATENE CAB. MARINAIO (PORTA NEMO)	LAMINATO CLEAF SABLE ¹	1	Damiano

1 - L 444 x H 1315 x sp 30mm

FERRAMENTA:

N° 1 - SERRATURA + RISCONTRO RAZETO CASARETO

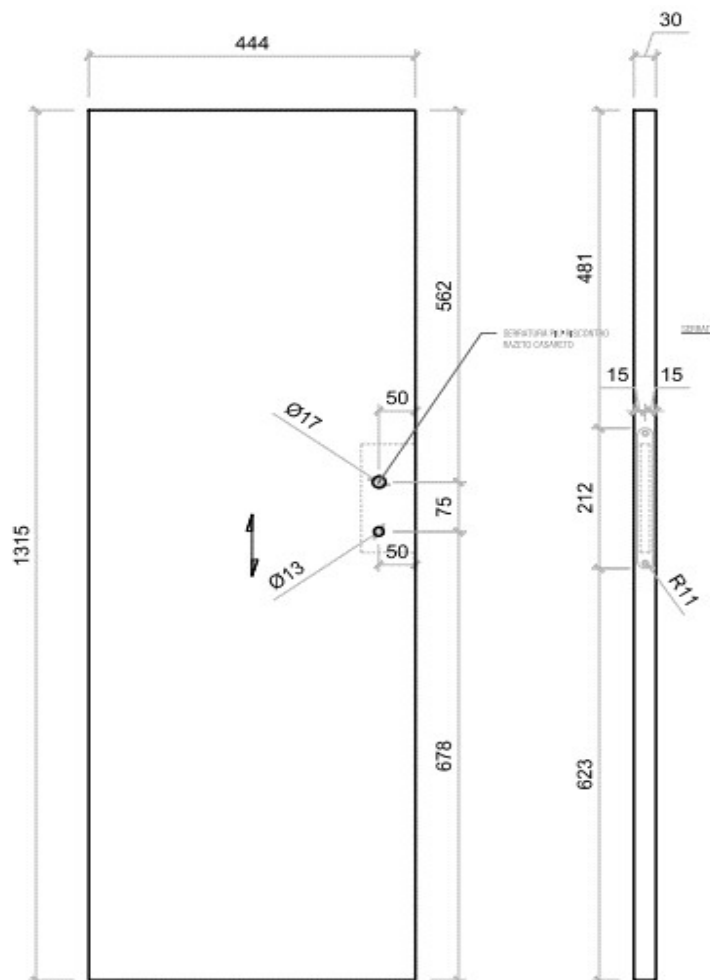

AZ26M

REV. GR 9

LOCALE	CODICE	DESCRIZIONE COMPONENTE	FINITURA	Q.TA	OPERATORE
PORTE	AZ26M-P4	PORTA BAGNO VIP DX	OKOUME' GREZZO	1	Damiano

1 - L 632 x H.44 x sp 5

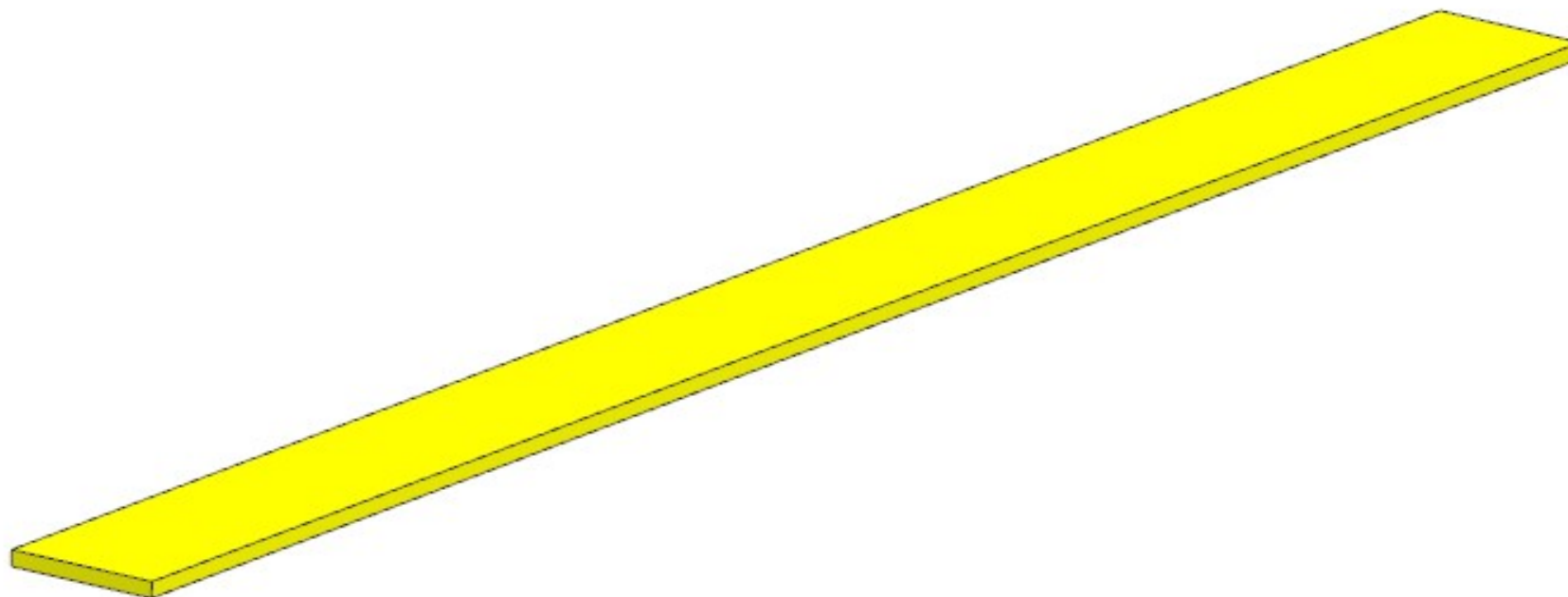

AZ26M

REV. GR 9

LOCALE	CODICE	DESCRIZIONE COMPONENTE	FINITURA	Q.TA	OPERATORE
PORTE	AZ26M-R01_P4	PORTA BAGNO VIP DX	LASTRA CHIARA	1	Damiano



consonni&c

AZ26M

REV. GR 9

LOCALE	CODICE	DESCRIZIONE COMPONENTE	FINITURA	Q.TA	OPERATORE
PORTE	AZ26M-A01_P4	PORTA BAGNO VIP DX	ACCIAIO	1	Damiano

1 - L 561 x H 21 x 86mm

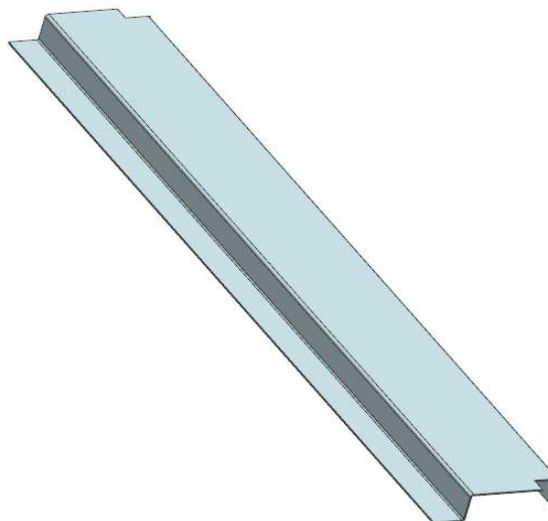

DETTAGLIO

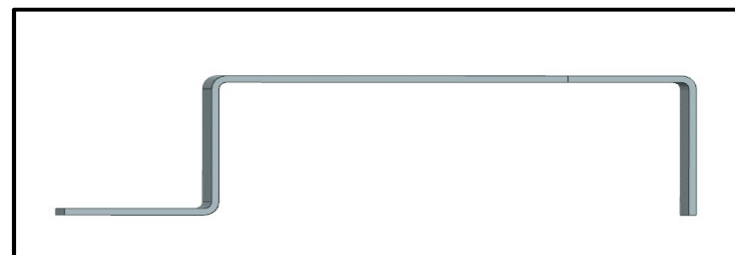

consonni&c

AZ26M

REV. GR 9

LOCALE	CODICE	DESCRIZIONE COMPONENTE	FINITURA	Q.TA	OPERATORE
PORTE	AZ26M-P5	PORTA BAGNO VIP SX	OKOUME' GREZZO	1	Damiano

1 - L 632 x H.44 x sp 5

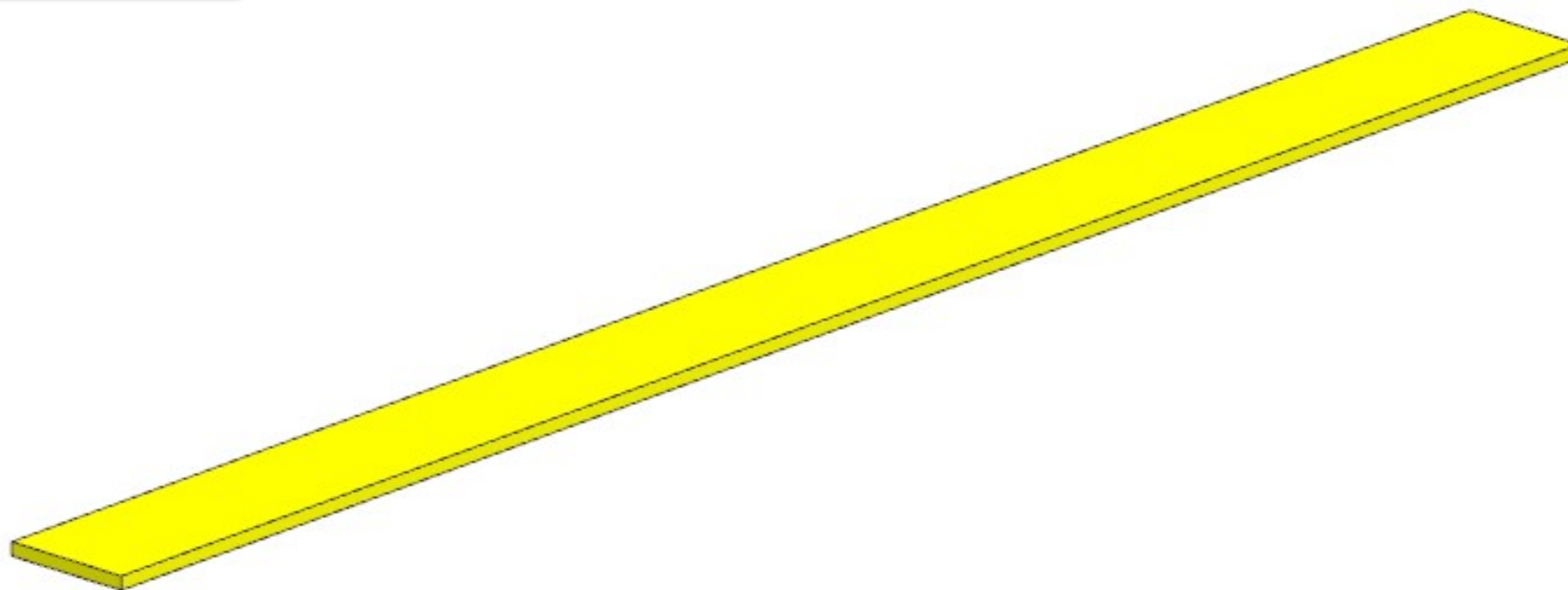

AZ26M

REV. GR 9

LOCALE	CODICE	DESCRIZIONE COMPONENTE	FINITURA	Q.TA	OPERATORE
PORTE	AZ26M-R01_P5	PORTA BAGNO VIP SX	LASTRA CHIARA	1	Damiano

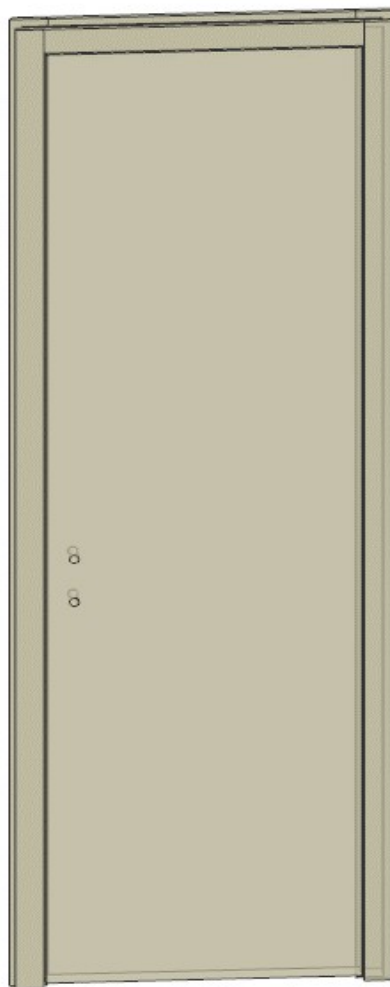

AZ26M

REV. GR 9

LOCALE	CODICE	DESCRIZIONE COMPONENTE	FINITURA	Q.TA	OPERATORE
PORTE	AZ26M-A01_P5	PORTA BAGNO VIP SX	ACCIAIO	1	Damiano

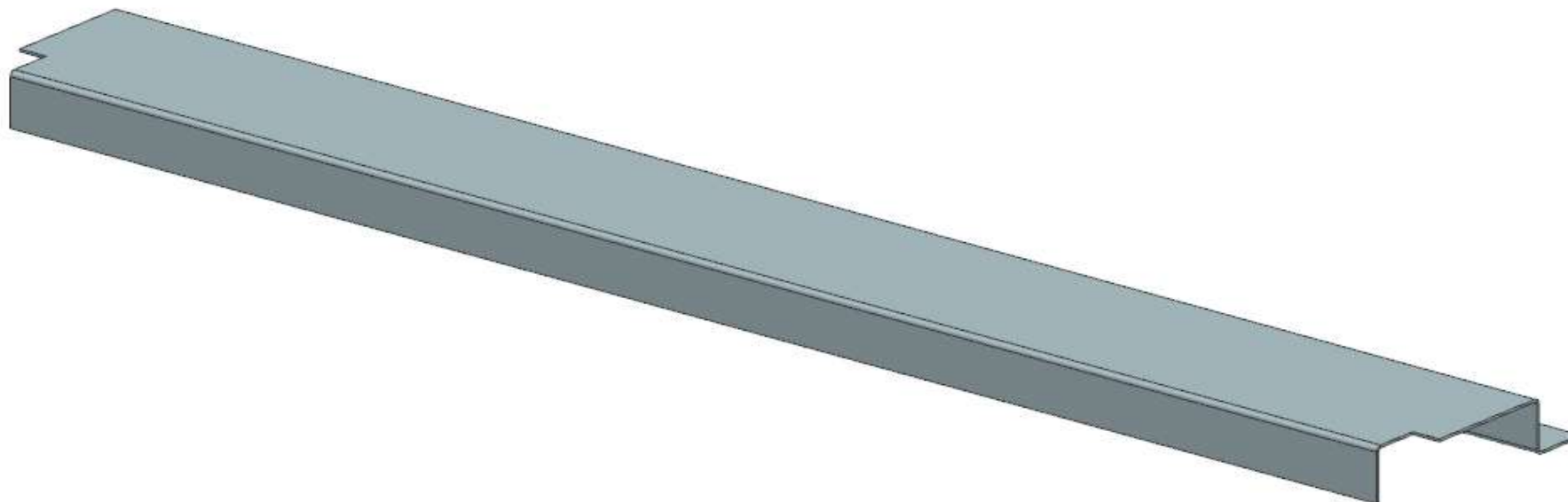

DETTAGLIO



consonni&c

AZ26M

REV. GR 9

LOCALE	CODICE	DESCRIZIONE COMPONENTE	FINITURA	Q.TA	OPERATORE
PORTE	AZ26M-P6	PORTA CABINA VIP DX	OKOUME' GREZZO	1	Damiano

1 - L 632 x H.44 x sp 5

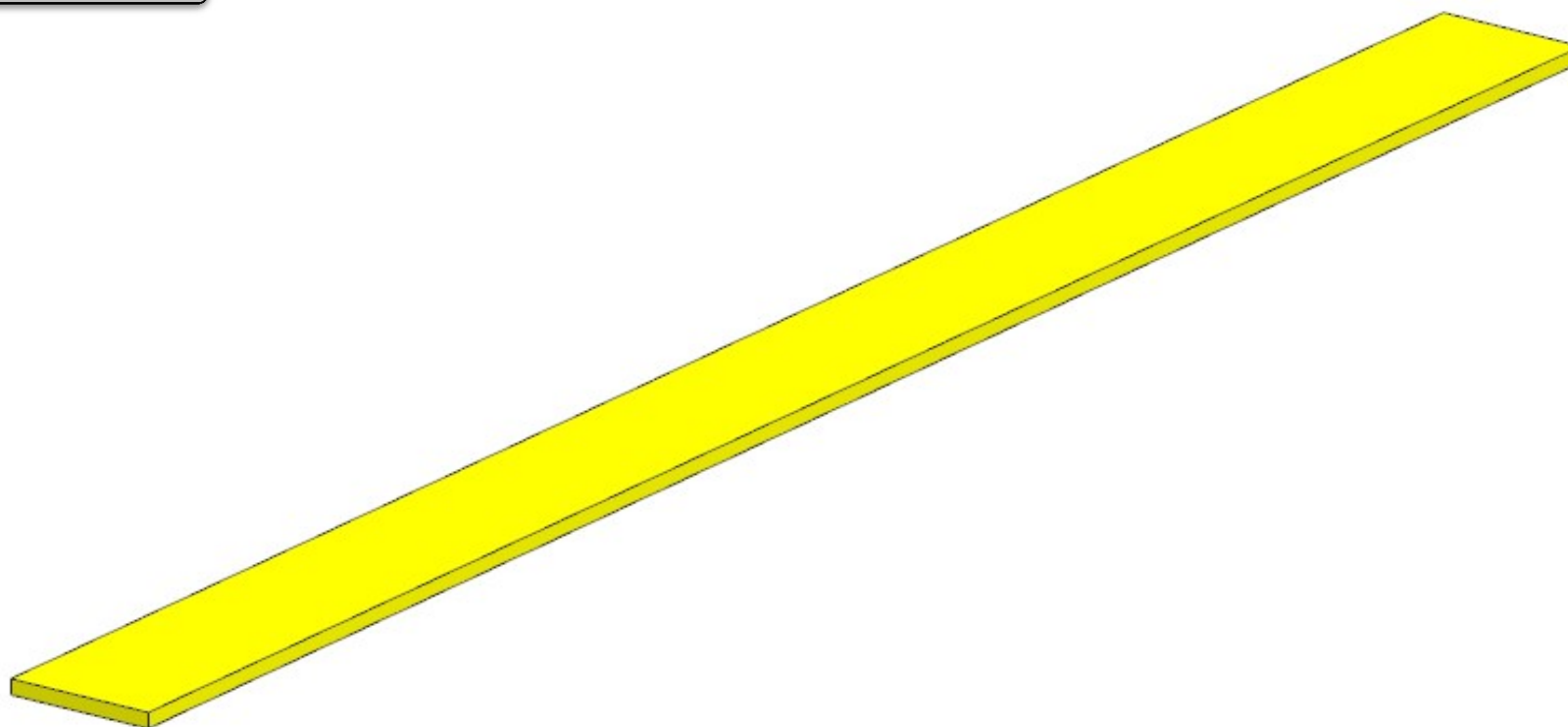

AZ26M

REV. GR 9

LOCALE	CODICE	DESCRIZIONE COMPONENTE	FINITURA	Q.TA	OPERATORE
PORTE	AZ26M-R01_P6	PORTA CABINA VIP DX	LASTRA CHIARA	1	Damiano



consonni&c

AZ26M

REV. GR 9

LOCALE	CODICE	DESCRIZIONE COMPONENTE	FINITURA	Q.TA	OPERATORE
PORTE	AZ26M-A01_P6	PORTA CABINA VIP DX	ACCIAIO	1	Damiano

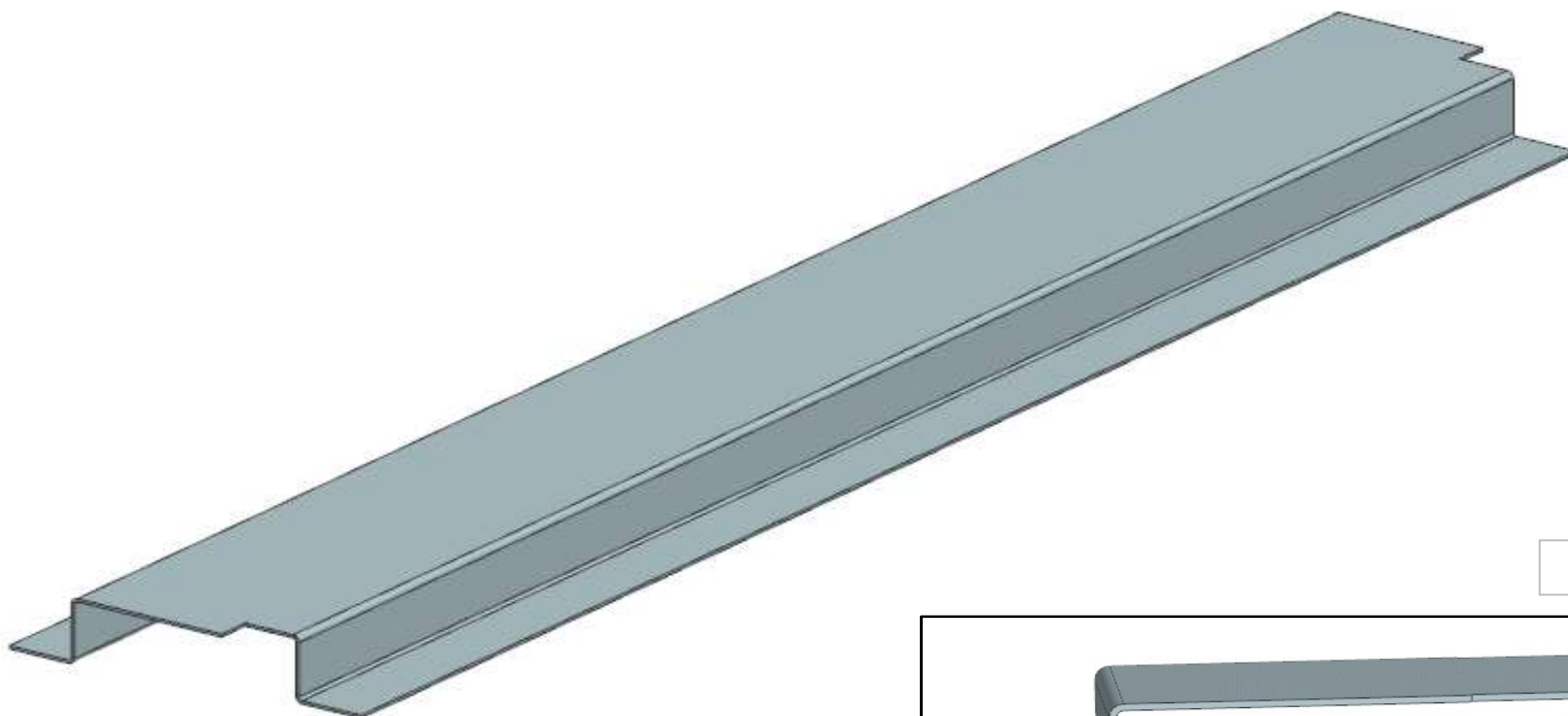

DETTAGLIO

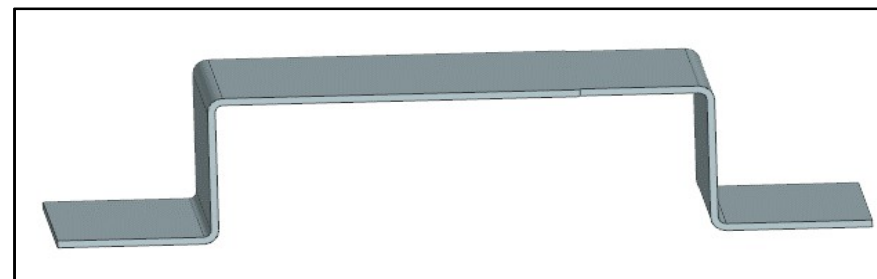

consonni&c

AZ26M

REV. GR 9

LOCALE	CODICE	DESCRIZIONE COMPONENTE	FINITURA	Q.TA	OPERATORE
PORTE	AZ26M-P7	PORTA CABINA VIP SX	OKOUME' GREZZO	1	Damiano

1 - L 632 x H.44 x sp 5

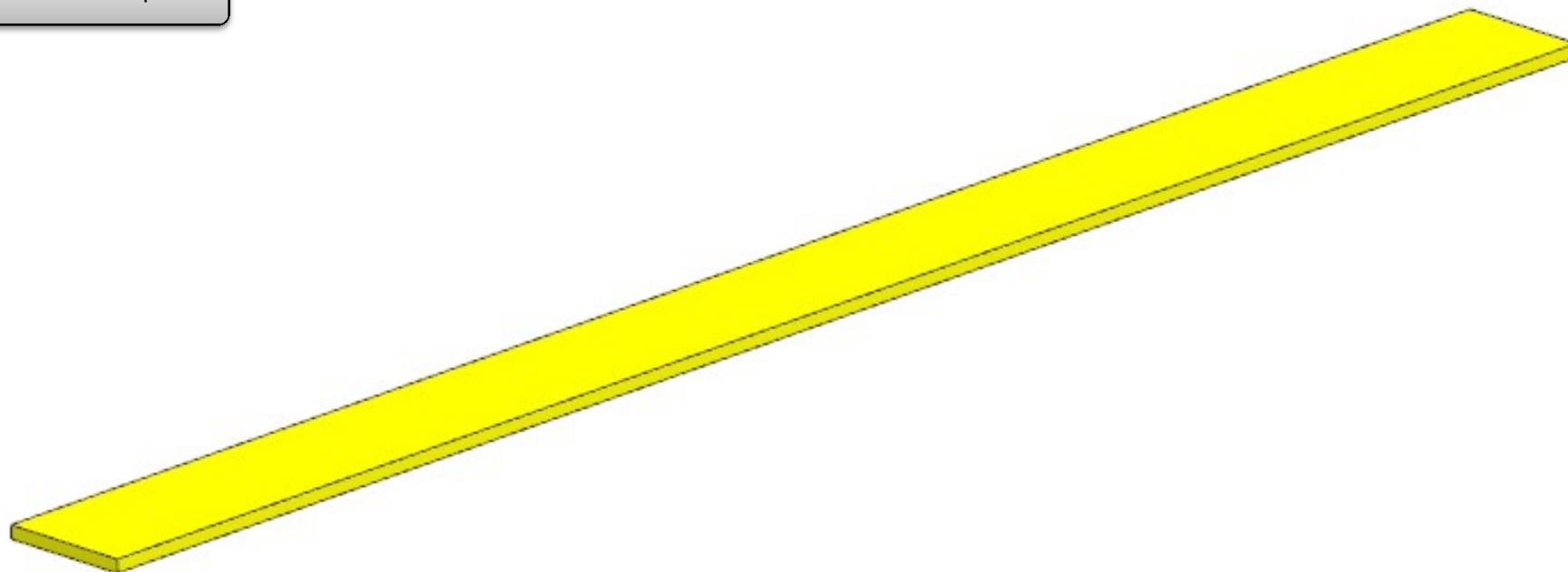

AZ26M

REV. GR 9

LOCALE	CODICE	DESCRIZIONE COMPONENTE	FINITURA	Q.TA	OPERATORE
PORTE	AZ26M-R01_P7	PORTA CABINA VIP SX	LASTRA CHIARA	1	Damiano

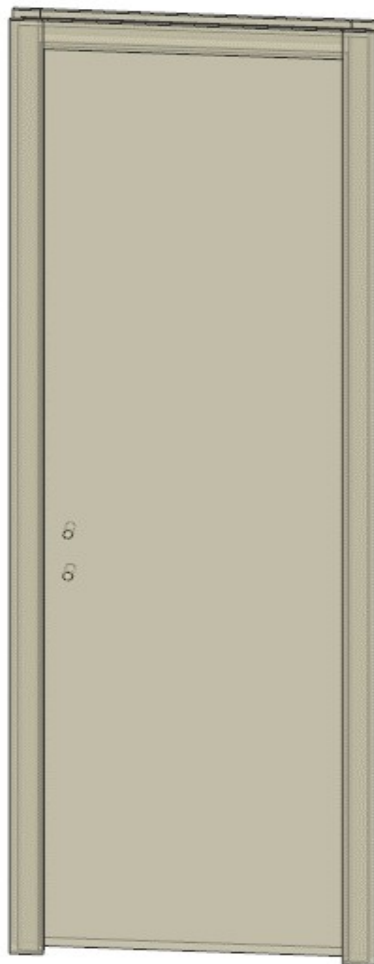

AZ26M

REV. GR 9

LOCALE	CODICE	DESCRIZIONE COMPONENTE	FINITURA	Q.TA	OPERATORE
PORTE	AZ26M-A01_P7	PORTA CABINA VIP SX	ACCIAIO	1	Damiano

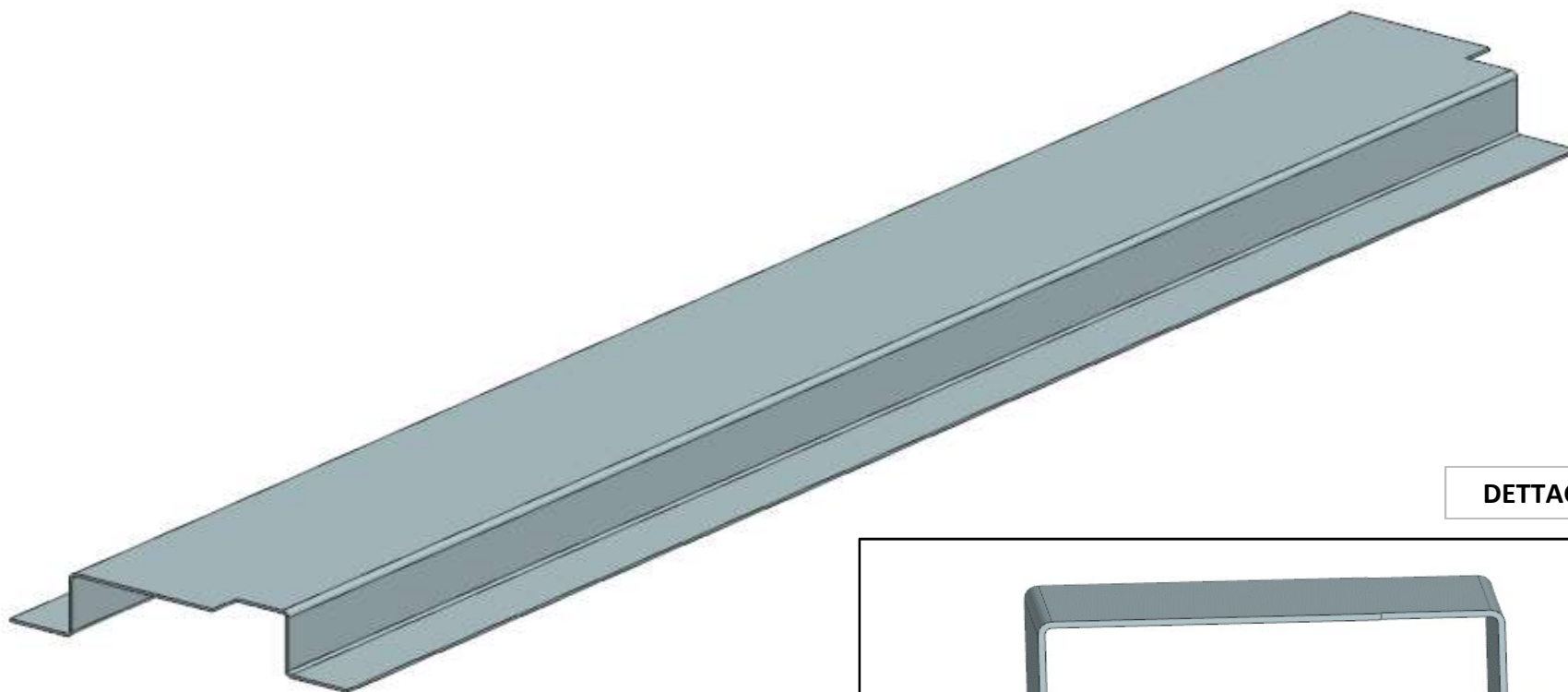

DETTAGLIO

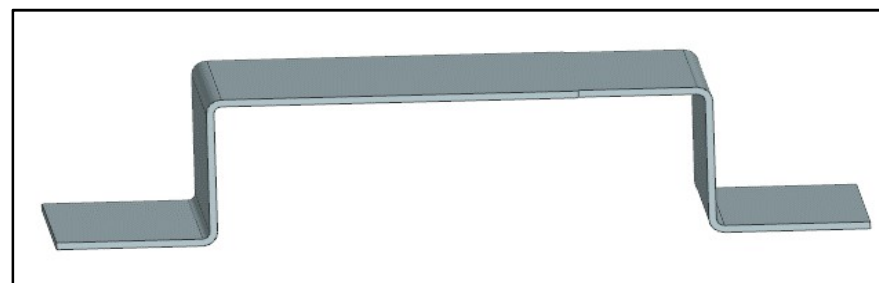

consonni&c

AZ26M

REV. GR 9

LOCALE	CODICE	DESCRIZIONE COMPONENTE	FINITURA	Q.TA	OPERATORE
PORTE	AZ26M-P8	PORTA CABINA OSPITI DX	OKOUME' GREZZO	1	Damiano

1 - L 632 x H.44 x sp 5

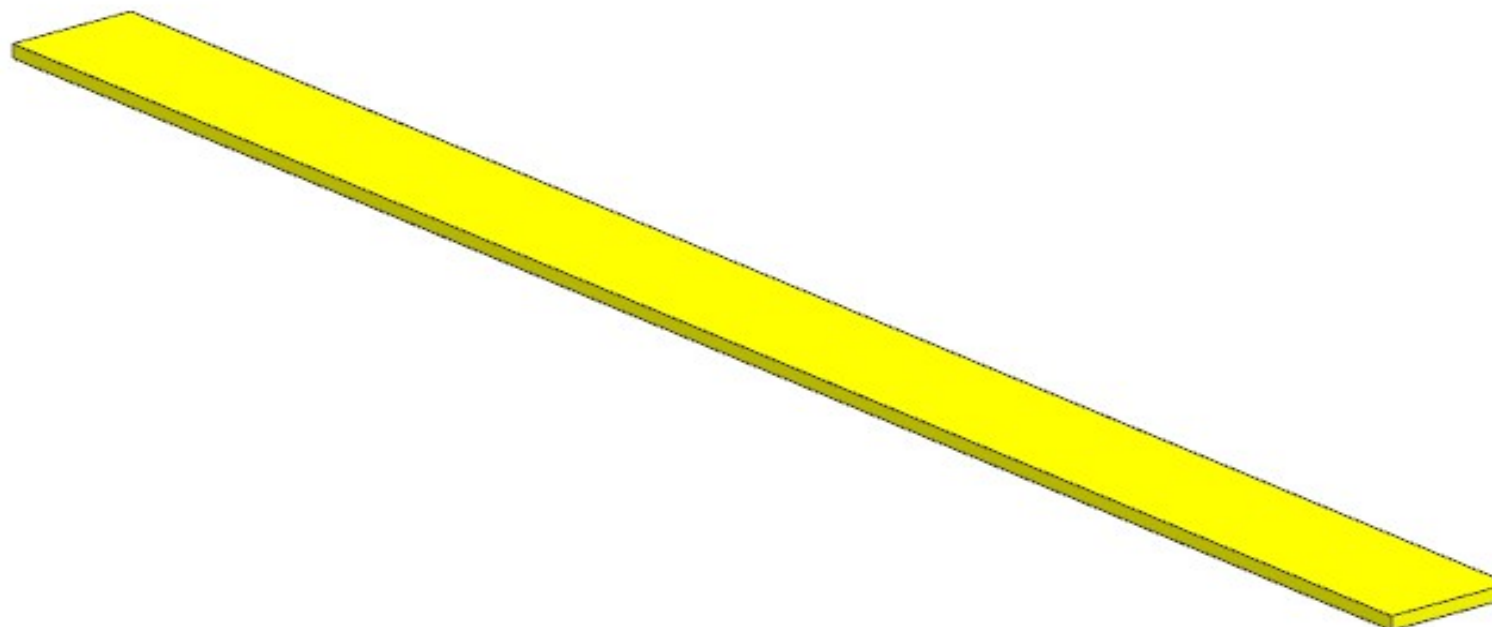

AZ26M

REV. GR 9

LOCALE	CODICE	DESCRIZIONE COMPONENTE	FINITURA	Q.TA	OPERATORE
PORTE	AZ26M-R01_P8	PORTA CABINA OSPITI DX	LASTRA CHIARA	1	Damiano

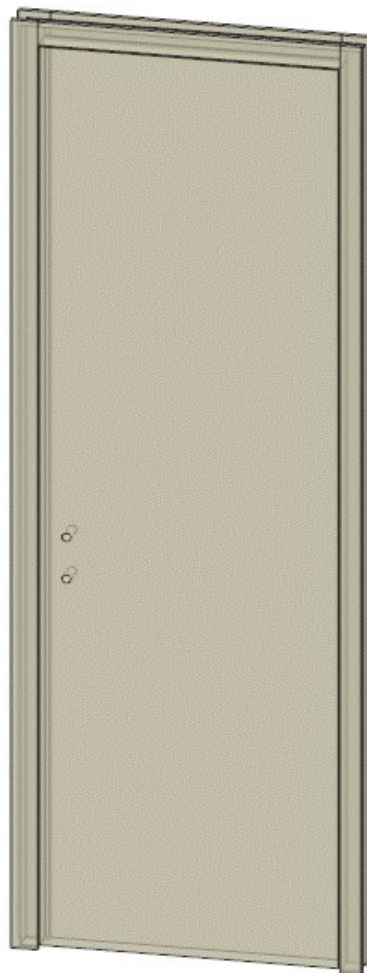

consonni&c

AZ26M

REV. GR 9

LOCALE	CODICE	DESCRIZIONE COMPONENTE	FINITURA	Q.TA	OPERATORE
PORTE	AZ26M-A01_P8	PORTA CABINA OSPITI DX	ACCIAIO	1	Damiano

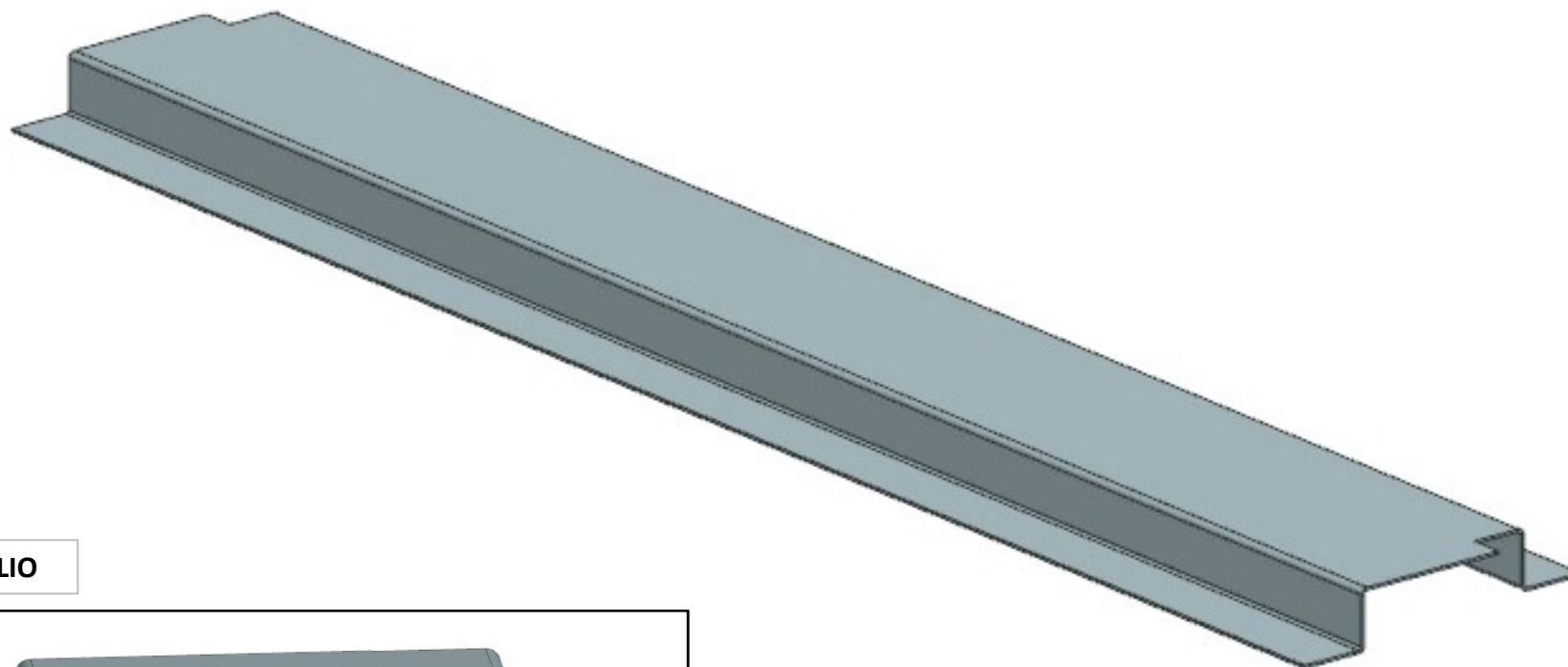

DETTAGLIO

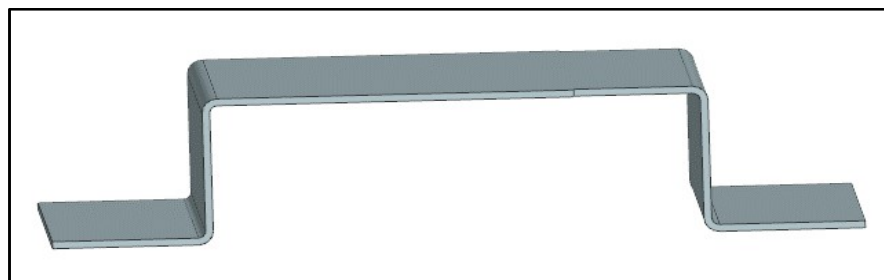

AZ26M

REV. GR 9

LOCALE	CODICE	DESCRIZIONE COMPONENTE	FINITURA	Q.TA	OPERATORE
PORTE	AZ26M-P9	PORTA BAGNO OSPITI DX	OKOUME' GREZZO	1	Damiano

1 - L 632 x H.44 x sp 5

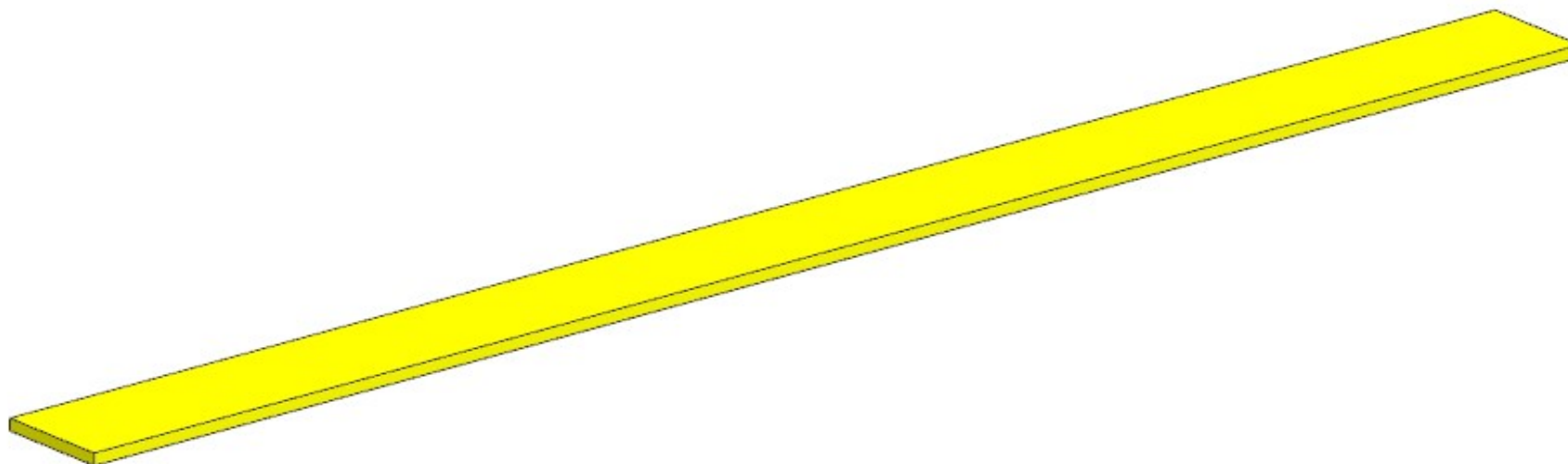

AZ26M

REV. GR 9

LOCALE	CODICE	DESCRIZIONE COMPONENTE	FINITURA	Q.TA	OPERATORE
PORTE	AZ26M-R01_P9	PORTA BAGNO OSPITI DX	LASTRA CHIARA	1	Damiano

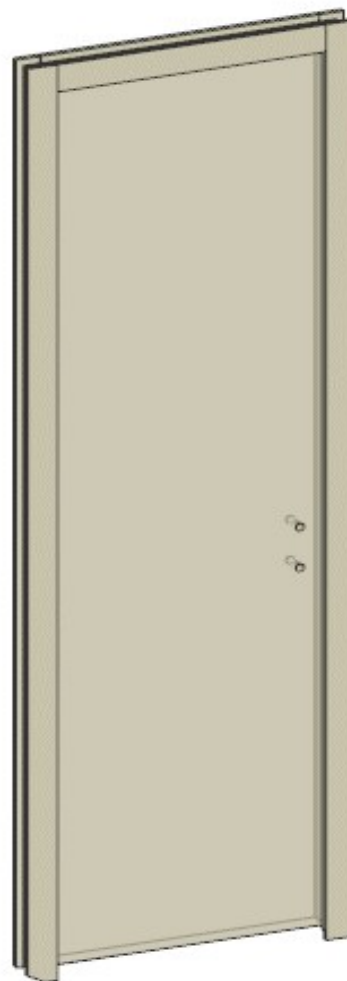

consonni&c

AZ26M

REV. GR 9

LOCALE	CODICE	DESCRIZIONE COMPONENTE	FINITURA	Q.TA	OPERATORE
PORTE	AZ26M-A01_P9	PORTA BAGNO OSPITI DX	ACCIAIO	1	Damiano

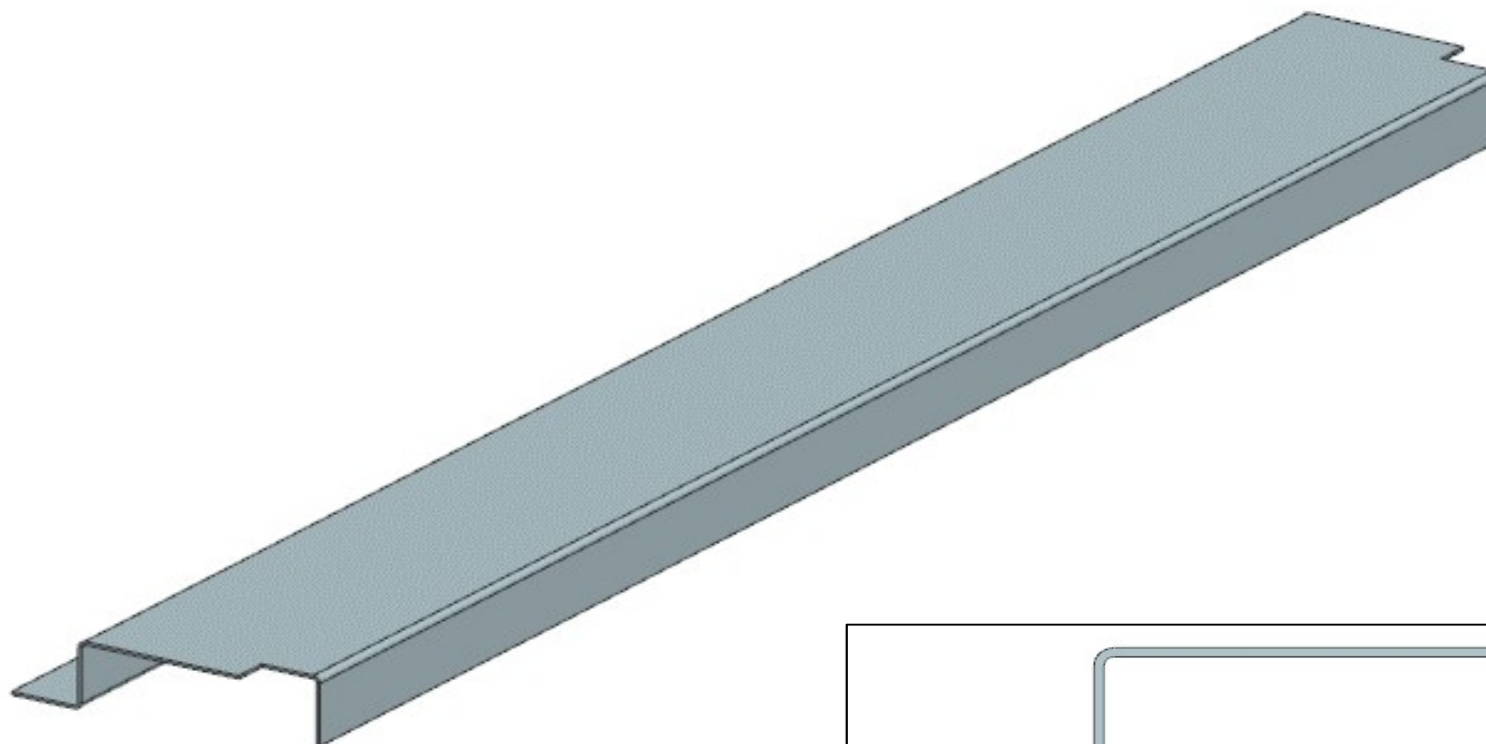

DETTAGLIO



consonni&c

AZ26M

REV. GR 9

LOCALE	CODICE	DESCRIZIONE COMPONENTE	FINITURA	Q.TA	OPERATORE
PORTE	AZ26M-P10	PORTA CABINA OSPITI SX	OKOUME' GREZZO	1	Damiano

1 - L 632 x H.44 x sp 5

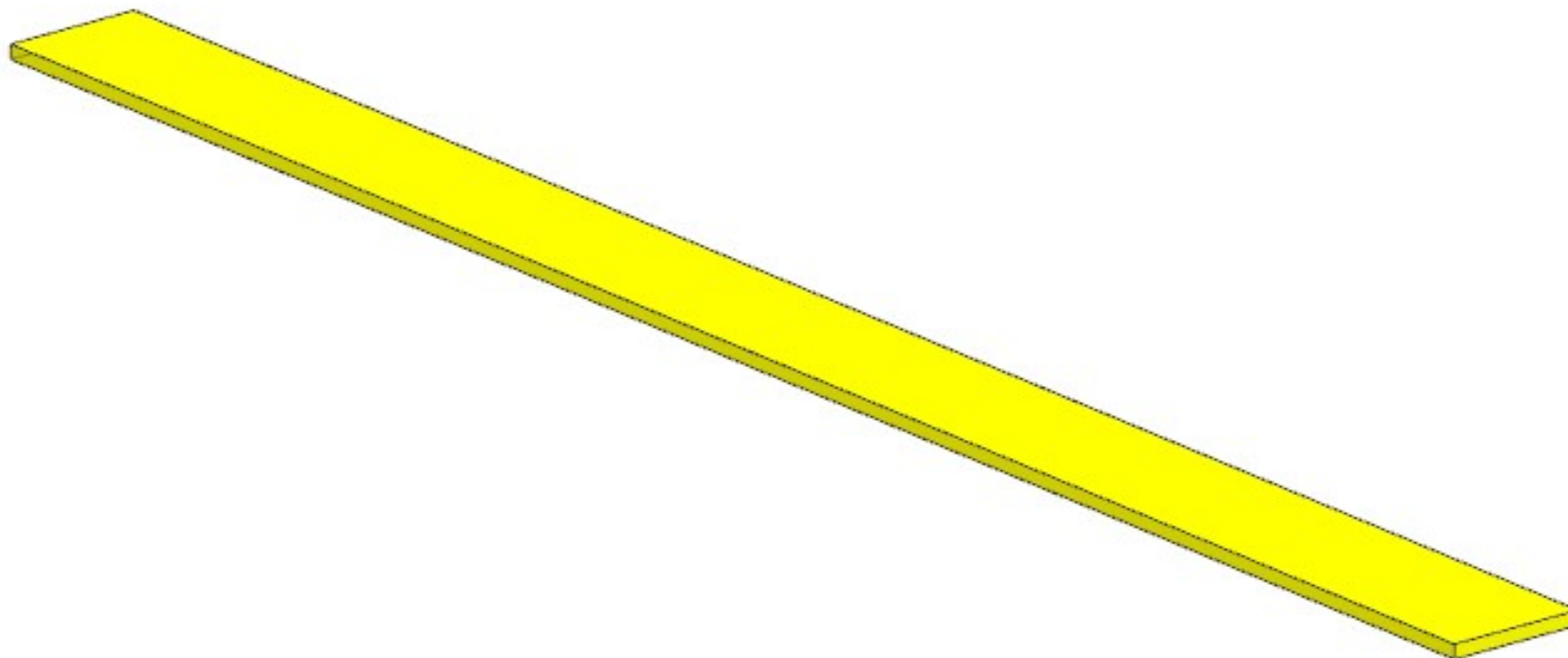

AZ26M

REV. GR 9

LOCALE	CODICE	DESCRIZIONE COMPONENTE	FINITURA	Q.TA	OPERATORE
PORTE	AZ26M-R01_P10	PORTA CABINA OSPITI SX	LASTRA CHIARA	1	Damiano

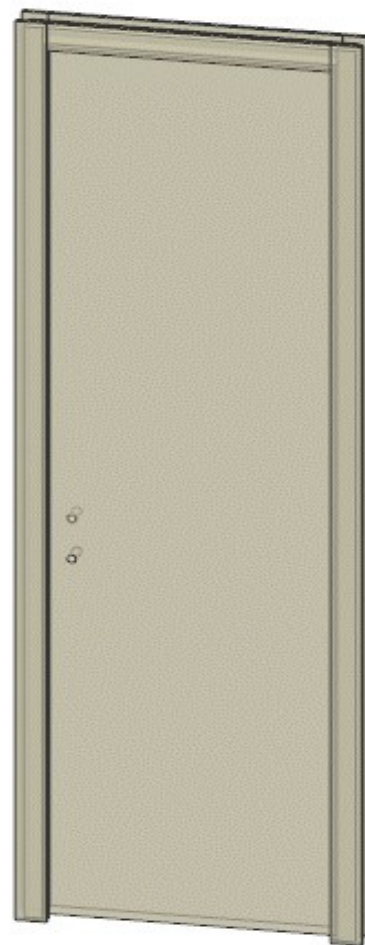

consonni&c

AZ26M

REV. GR 9

LOCALE	CODICE	DESCRIZIONE COMPONENTE	FINITURA	Q.TA	OPERATORE
PORTE	AZ26M-A01_P10	PORTA CABINA OSPITI SX	ACCIAIO	1	Damiano

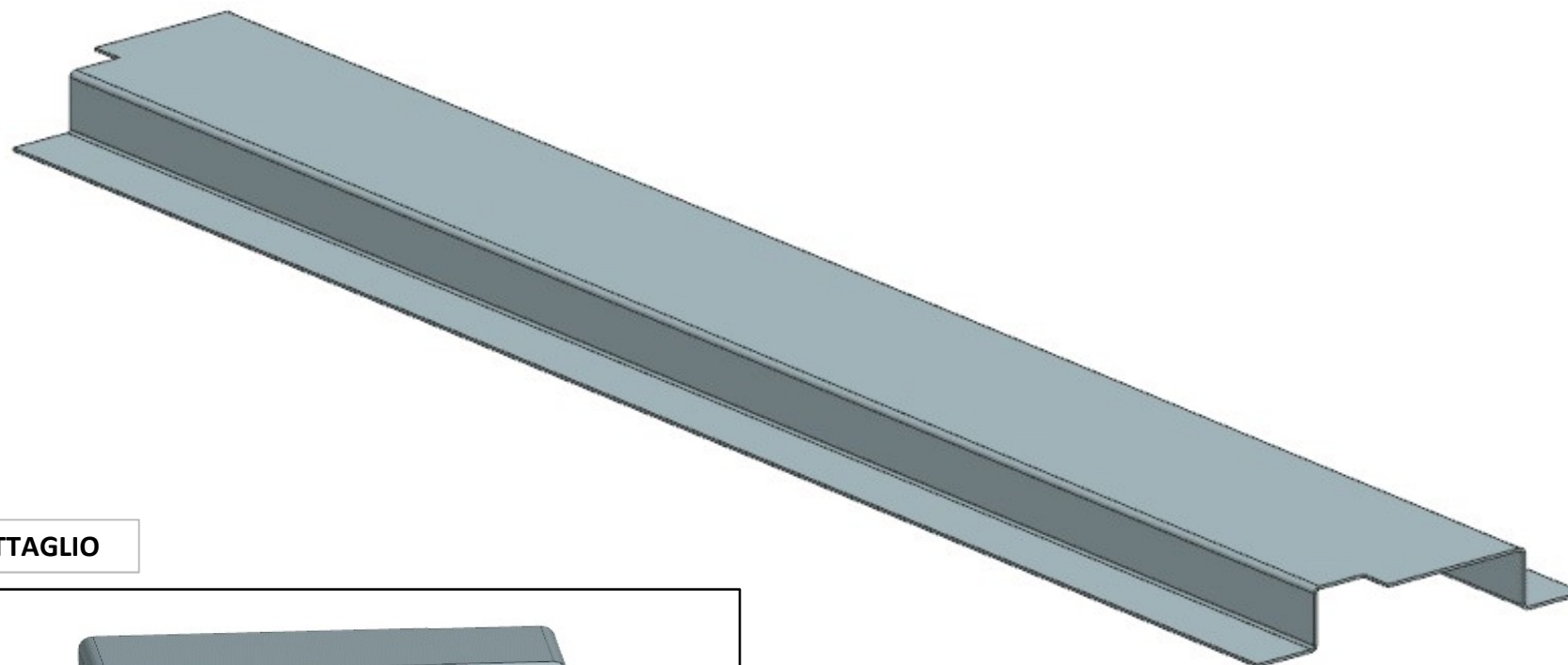

DETTAGLIO

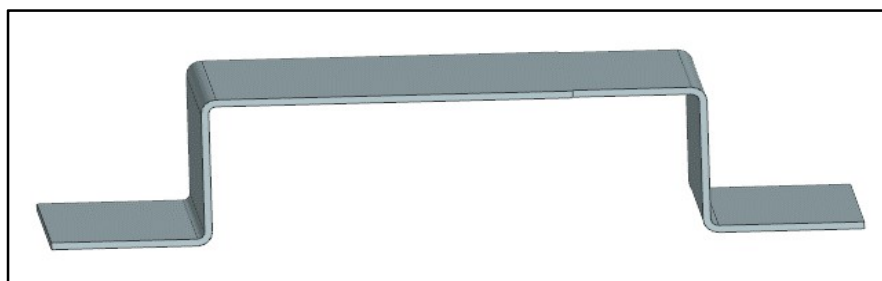

consonni&c

AZ26M

REV. GR 9

LOCALE	CODICE	DESCRIZIONE COMPONENTE	FINITURA	Q.TA	OPERATORE
PORTE	AZ26M-P11	PORTA BAGNO OSPITI SX	OKOUME' GREZZO	1	Damiano

1 - L 632 x H.44 x sp 5

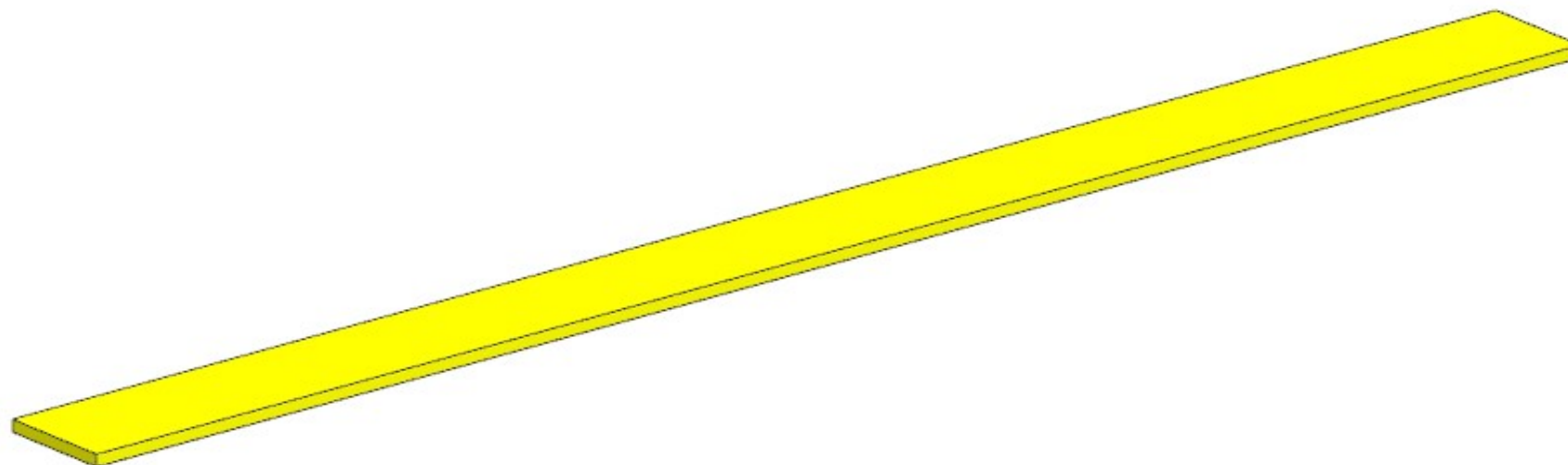

AZ26M

REV. GR 9

LOCALE	CODICE	DESCRIZIONE COMPONENTE	FINITURA	Q.TA	OPERATORE
PORTE	AZ26M-R01_P11	PORTA BAGNO OSPITI SX	LASTRA CHIARA	1	Damiano

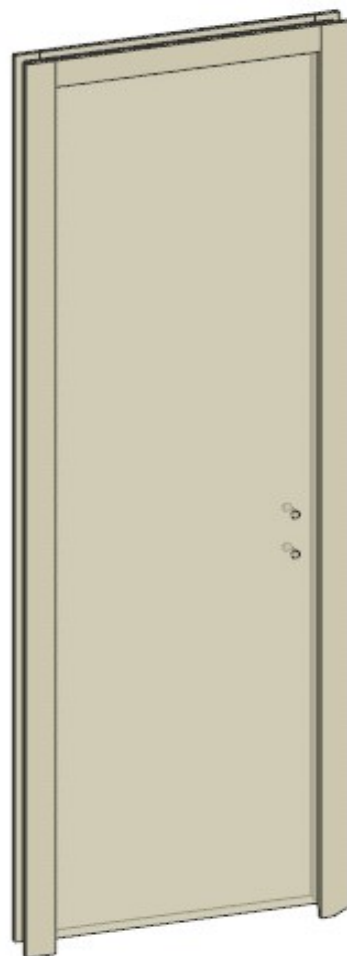

consonni&c

AZ26M

REV. GR 9

LOCALE	CODICE	DESCRIZIONE COMPONENTE	FINITURA	Q.TA	OPERATORE
PORTE	AZ26M-A01_P11	PORTA BAGNO OSPITI SX	ACCIAIO	1	Damiano

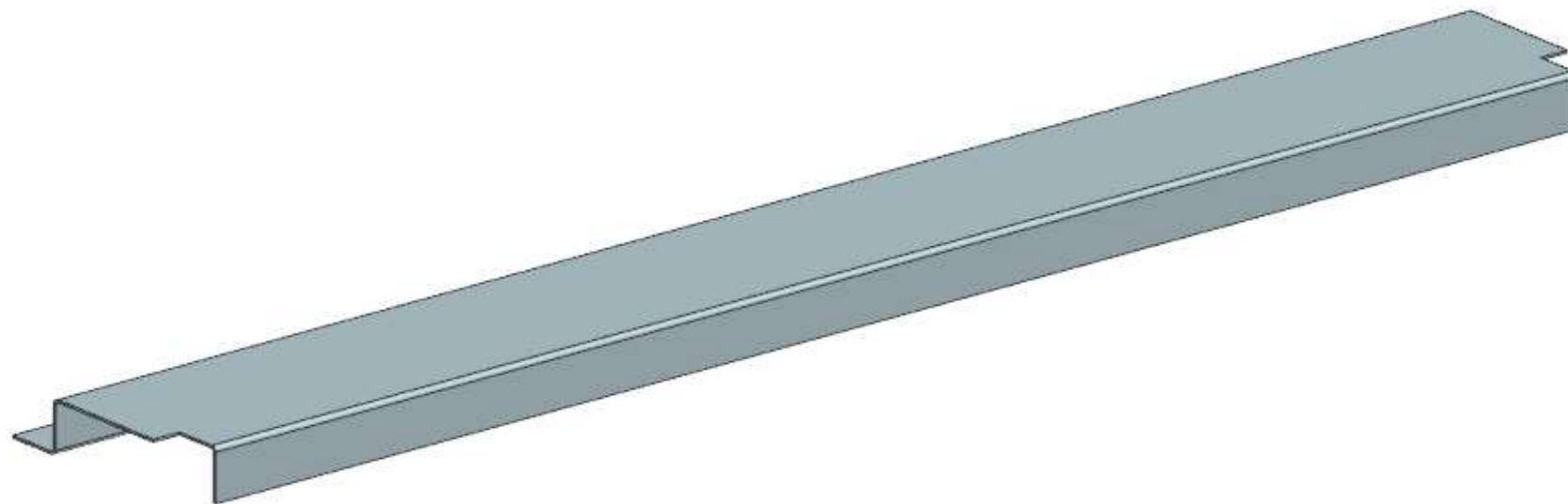

DETTAGLIO



consonni&c

AZ26M

REV. 01-2023

REV. GR 9

LOCALE	CODICE	DESCRIZIONE COMPONENTE	FINITURA	Q.TA	OPERATORE
CABINA VIP DX	AZ26M-MF_VA01\VA02	STRUTTURA MURATA TESTATA LETTO		4	Damiano

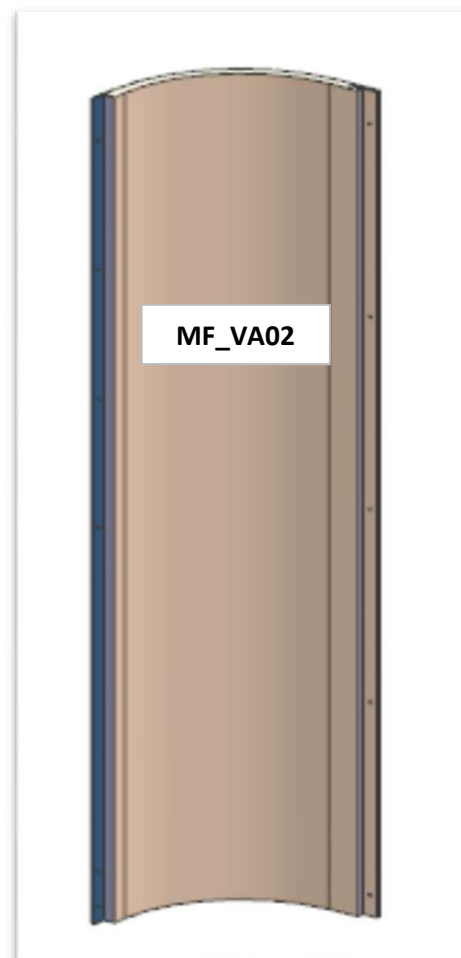
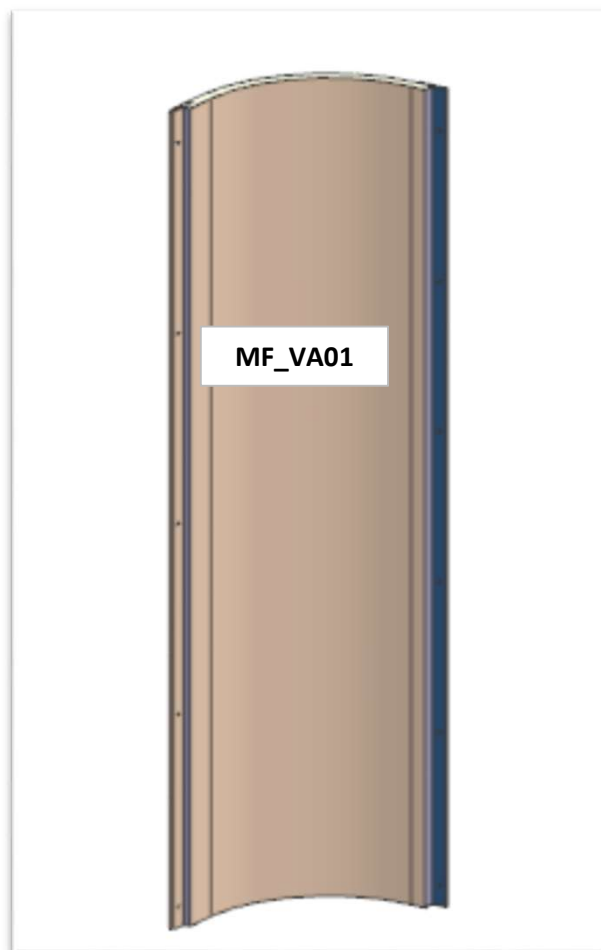

FERRAMENTA:

- N° 40 - FITLOCK FEMMINA
- N° 40 - FITLOCK MASCHIO
- N° 10 - VITI 6MA

AZ26M

GR5

REV. GR 9

LOCALE	CODICE	DESCRIZIONE COMPONENTE	FINITURA	Q.TA	OPERATORE
CABINA VIP DX	AZ26M-L01_VA01	STRUTTURA MURATA TESTATA LETTO	LACCATO BIANCO RAL 9010	11	Damiano

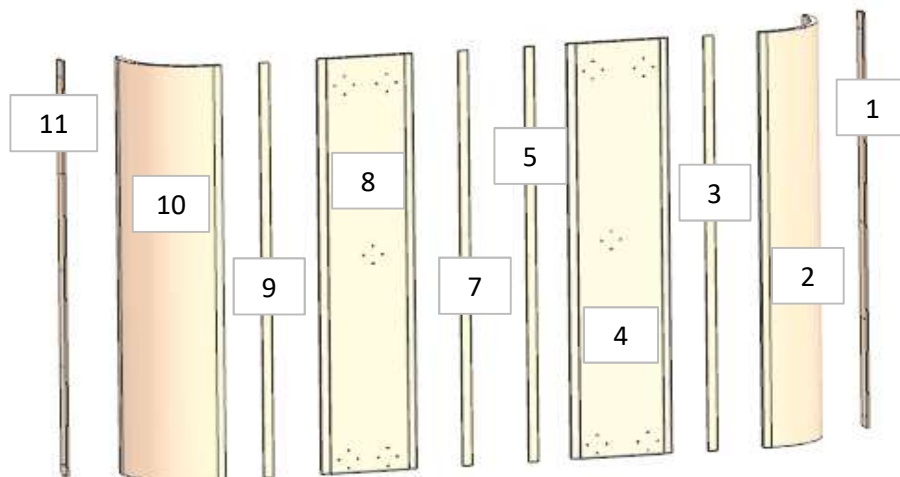

- 1 - 11 - L 40 x H 1160 x sp 6
- 2 - 10 - L 330 x H 1160 x sp 16
- 3 - 5 - 7 - 9 - L 25 x H 1160 x sp 6
- 4 - L 263 x H 1160 x sp 16
- 6 - L 1781 x H 1267 x sp 16
- 8 - L 248 x H 1160 x sp 16

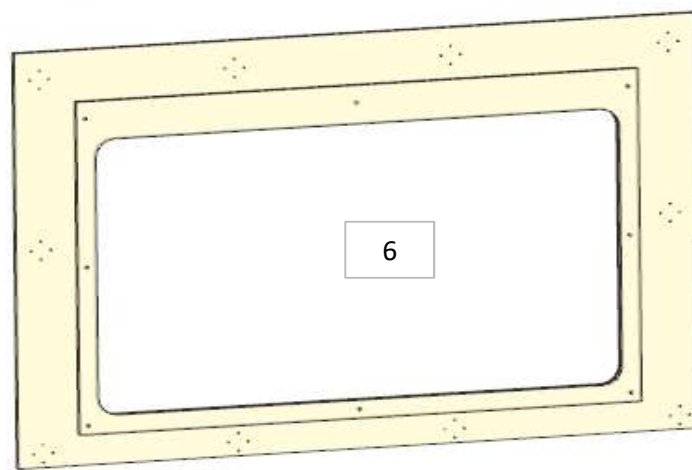

**ELEMENTI DA MONTARE COME IMMAGINI
e spedire con un unico imballo**

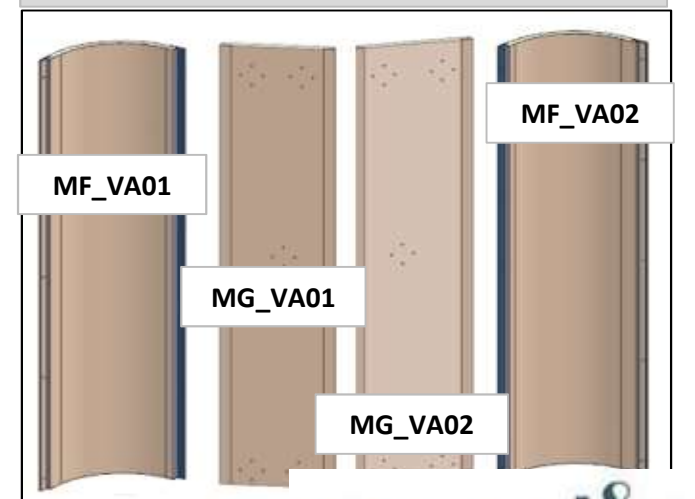

consonni&c

AZ26M

REV. 01-2023

REV. GR 9

LOCALE	CODICE	DESCRIZIONE COMPONENTE	FINITURA	Q.TA	OPERATORE
CABINA VIP DX	AZ26M-X01_VA01	STRUTTURA MURATA TESTATA LETTO	LAMINATO NERO	2	Damiano

1 - 2 - L 40 x H.1160 x sp 3

1

2

ELEMENTO DA MONTARE
COME IMMAGINE
e spedire con un unico imballo

MOD AZ 216
RIMOSSI LAMINATI ALLA BASE

MF_VA01

MF_VA02

consonni&c

AZ26M

REV. GR 9

LOCALE	CODICE	DESCRIZIONE COMPONENTE	FINITURA	Q.TA	OPERATORE
CABINA VIP DX	AZ26M-MG_VA01\ VA02	STRUTTURA MURATA TESTATA LETTO		2	Damiano

MG_VA01

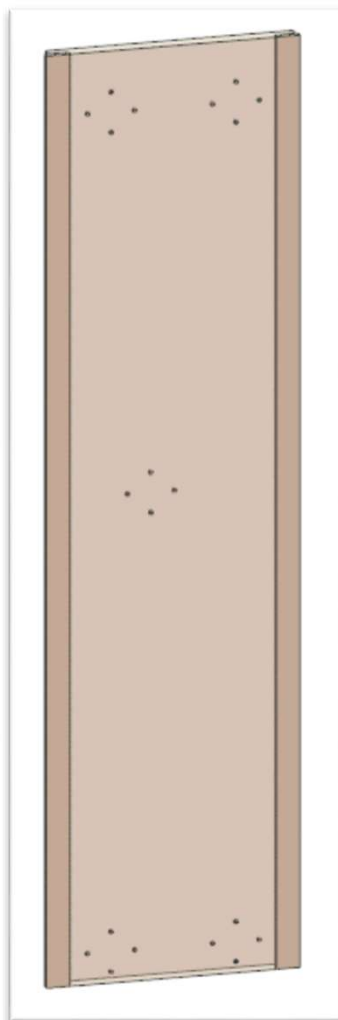

MG_VA02

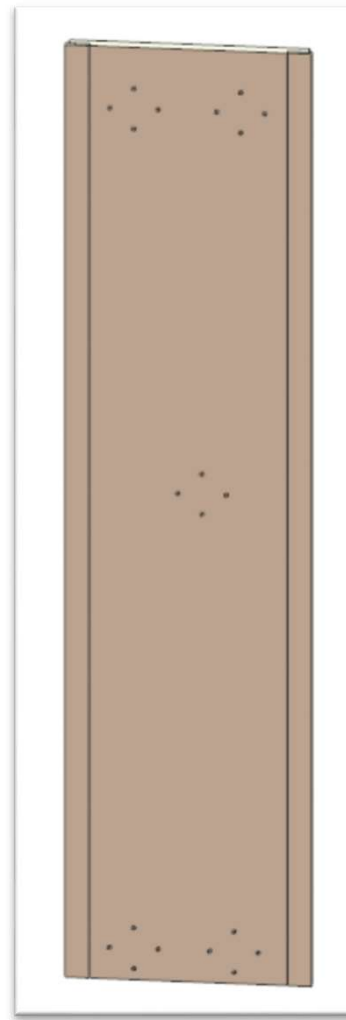

FERRAMENTA:

N° 40 - FITLOCK FEMMINA
N° 40 - FITLOCK MASCHIO
N° 10 - VITI 6MA

AZ26M

MOD DA GR5

REV. GR 9

LOCALE	CODICE	DESCRIZIONE COMPONENTE	FINITURA	Q.TA	OPERATORE
CABINA VIP DX	AZ26M-L02_VA01	STRUTTURA MURATA TESTATA LETTO	LACCATO NCS S3020-Y30R	4	Damiano

1 - 4 - L. 1451 x H.195 x sp 10
2 - 3 - L. 934 x H.195 x sp 10

MOD.146 DA GR.5 -
MODIFICATA PROFONDITA'
PANNELLI

PER LUCIDATURA:
1 LATO BELLO + TUTTI I FILI

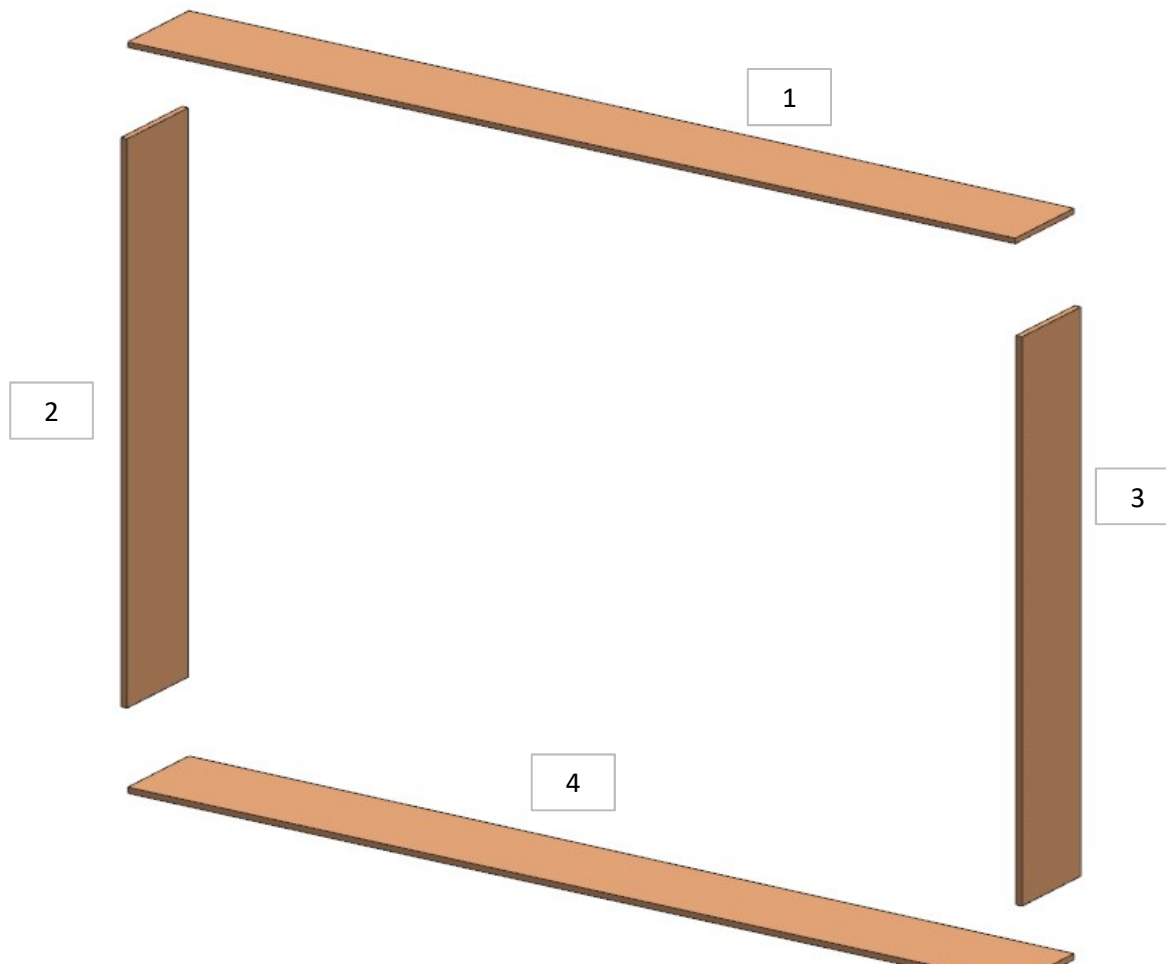

consonni&c

AZ26M

MOD DA GR9

REV. GR 9

LOCALE	CODICE	DESCRIZIONE COMPONENTE	FINITURA	Q.TA	OPERATORE
CABINA VIP DX	AZ26M-R01_VE01	RIVESTIMENTO PARETI PRUA	LASTRA CHIARA	4	Damiano

- 1 - SVILUPPO L 1429 x H.1624 x sp. 11
- 2 - SVILUPPO L 1429 x H.414 x sp. 11
- 3 - SVILUPPO L 1429 x H.385 x sp. 11
- 4- SVILUPPO L 1429 x H.414 x sp. 11

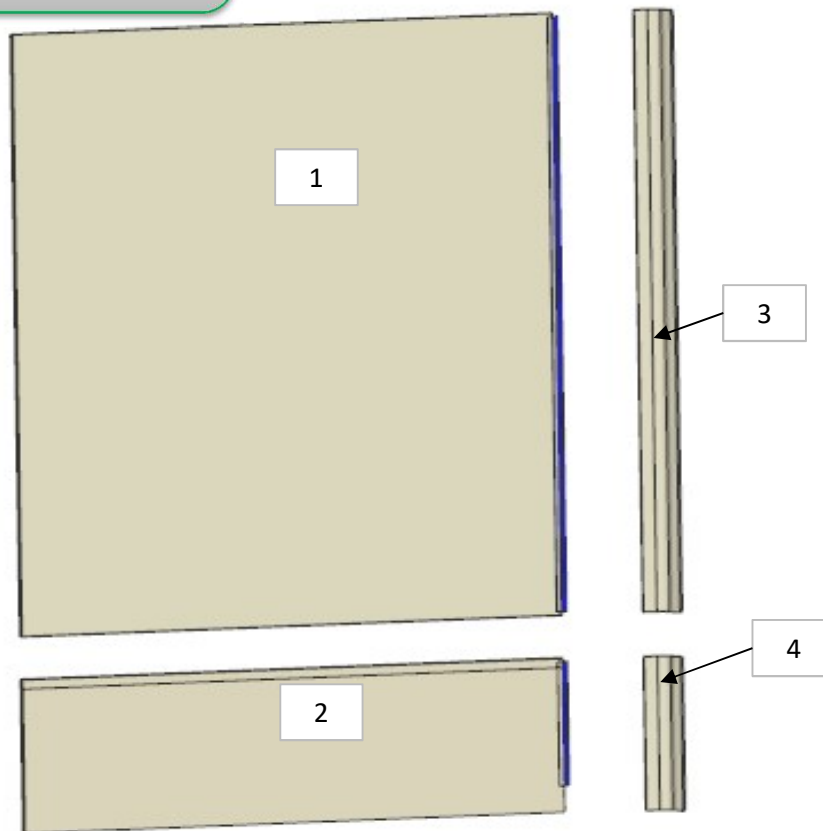

MOD AZ 216
ALLUNGATO
RIVESTIMENTI VERSO
PAVIMENTO ED
ELIMINATO LAMINATI

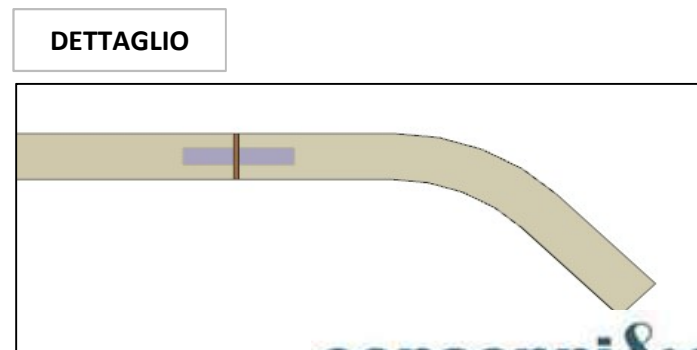

AZ26M

MOD DA GR9

REV. GR 9

LOCALE	CODICE	DESCRIZIONE COMPONENTE	FINITURA	Q.TA	OPERATORE
CABINA VIP DX	AZ26M-MF_VE01\VE02	RIVESTIMENTO PARETI PRUA			Damiano

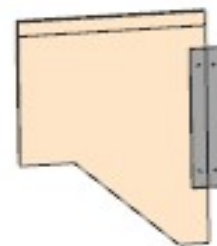
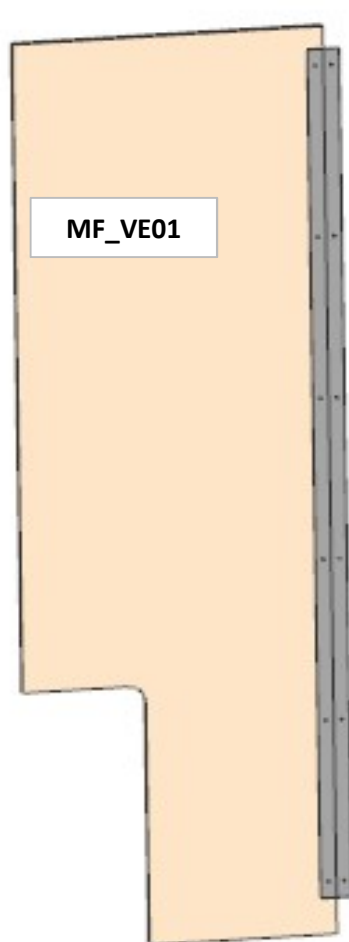

MOD AZ 216
ALLUNGATO
RIVESTIMENTI VERSO
PAVIMENTO ED
ELIMINATO LAMINATI

AZ26M

MOD DA GR9

REV. GR 9

LOCALE	CODICE	DESCRIZIONE COMPONENTE	FINITURA	Q.TA	OPERATORE
CABINA VIP DX	AZ26M-L01_VE01	RIVESTIMENTO PARETI PRUA	LACCATO BIANCO RAL 9010	2	Damiano

1 - L 486 x H 1624 x sp 10
2 - L 293 x H 414 x sp 10

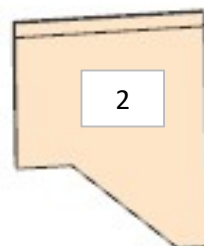
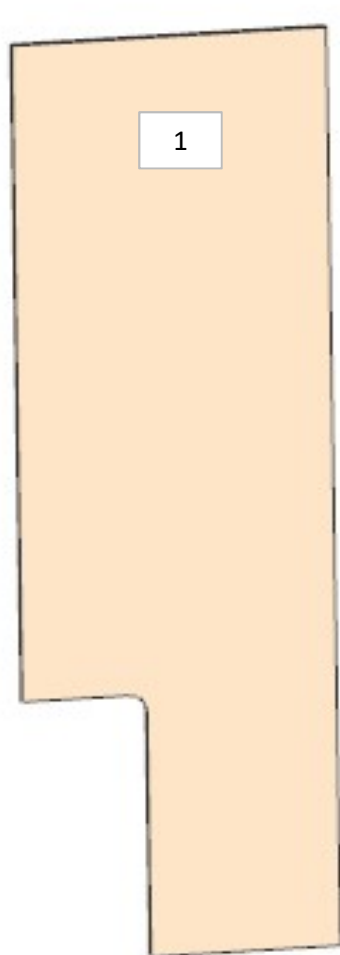

ELEMENTO DA MONTARE
con:
A01_VE01
e spedire con un unico
imballo

A01_VE01

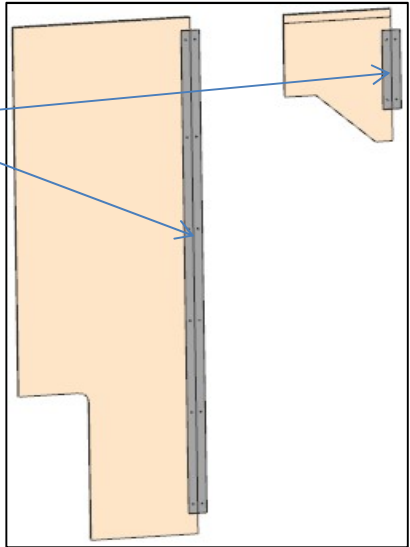

MOD AZ 216
ALLUNGATO
RIVESTIMENTI VERSO
PAVIMENTO ED
ELIMINATO LAMINATI

AZ26M

MOD DA GR9

REV. GR 9

LOCALE	CODICE	DESCRIZIONE COMPONENTE	FINITURA	Q.TA	OPERATORE
CABINA VIP DX	AZ26M-A01_VE01	RIVESTIMENTO PARETI PRUA	ALLUMINIO	2	Damiano

1 - L 1578 x H.50 x sp 2
2 - L 249 x H.50 x sp 2

2

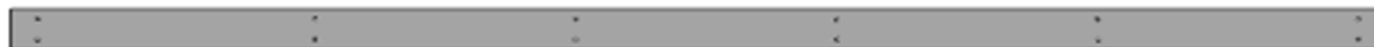
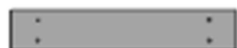

1

L01_VE01

MOD AZ 216
ALLUNGATO
RIVESTIMENTI VERSO
PAVIMENTO ED
ELIMINATO LAMINATI

ELEMENTO DA MONTARE
con:
L01_VE01
e spedire con un unico
imballo

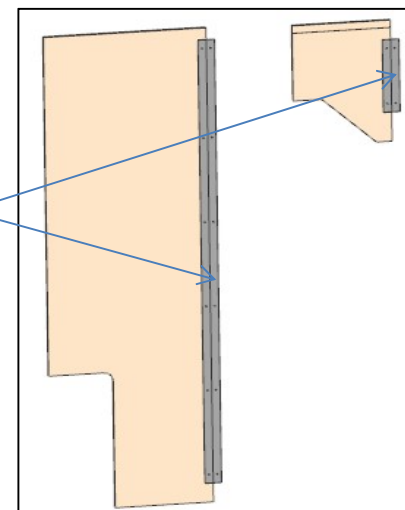

AZ26M

REV. GR 9

LOCALE	CODICE	DESCRIZIONE COMPONENTE	FINITURA	Q.TA	OPERATORE
CABINA VIP DX	AZ26M-A02_VE01	RIVESTIMENTO PARETI PRUA	ACCIAIO NERO	1	Damiano

1 - L.1726 x H.30 x sp 8

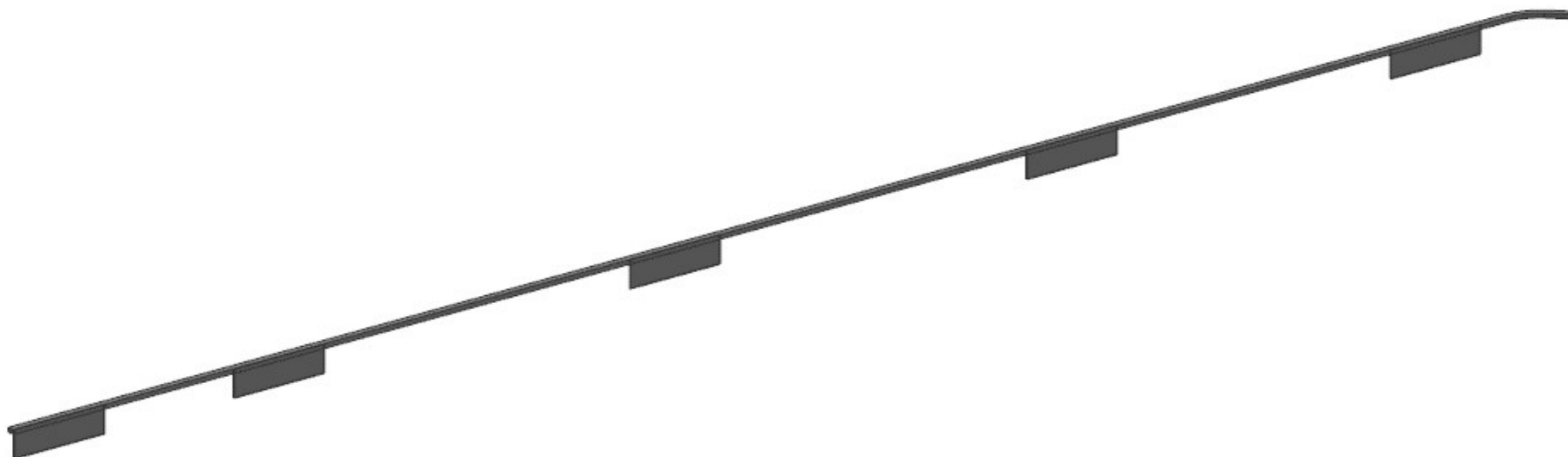

consonni&c

AZ26M

MOD DA GR9

REV. GR 9

LOCALE	CODICE	DESCRIZIONE COMPONENTE	FINITURA	Q.TA	OPERATORE
CABINA VIP DX	AZ26M-R01_VF01	RIVESTIMENTO PARETI POPPA	LASTRA CHIARA	8	Damiano

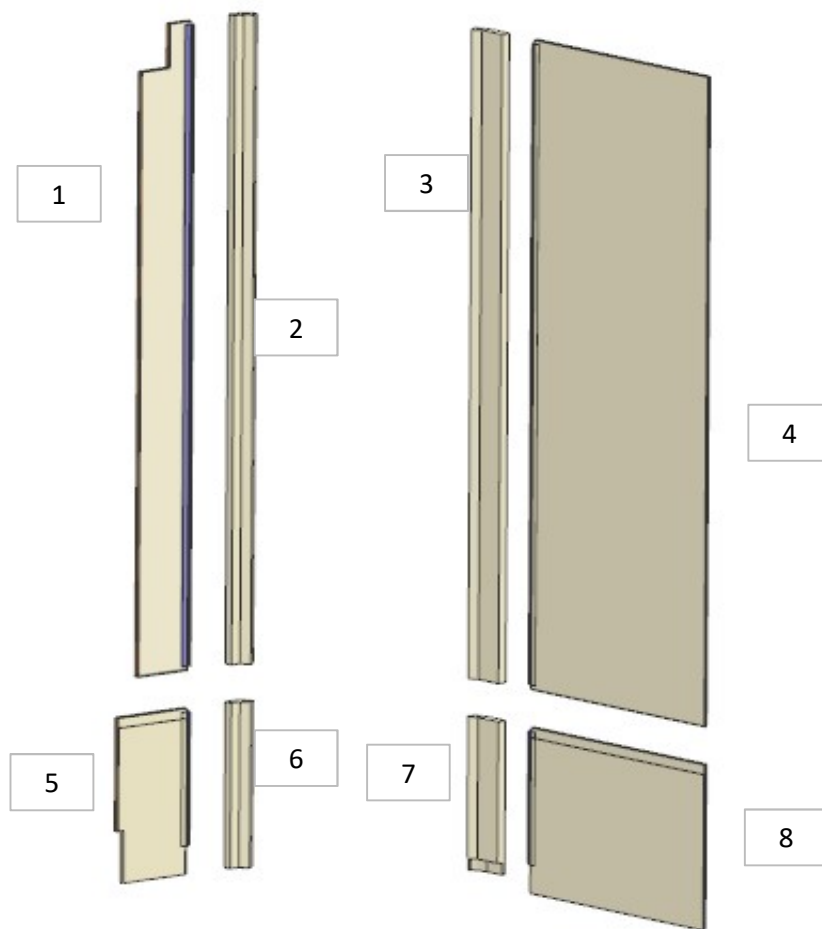

- 1 - L 143 x H.1624 x sp 11
- 2 - L 69 x H.1624 x sp 21
- 3 - L 105 x H.1624 x sp 21
- 4 - L 599 x H.1624 x sp 11
- 5 - L 200 x H. 414 x sp 11
- 6 - L 69 x H. 414 x sp 21
- 7 - L 105 x H. 414 x sp 21
- 8 - L 599 x H. 414 x sp 11

MOD AZ 216
 ALLUNGATO RIVESTIMENTI VERSO
 PAVIMENTO E RIMOSSI TUTTI I
 LAMINATI NERI ALLA BASE DEI
 RIVESTIMENTI

AZ26M

MOD DA GR9

REV. GR 9

LOCALE	CODICE	DESCRIZIONE COMPONENTE	FINITURA	Q.TA	OPERATORE
CABINA VIP DX	AZ26M-MF_VF01\VF02	RIVESTIMENTO PARETI POPPA			Damiano

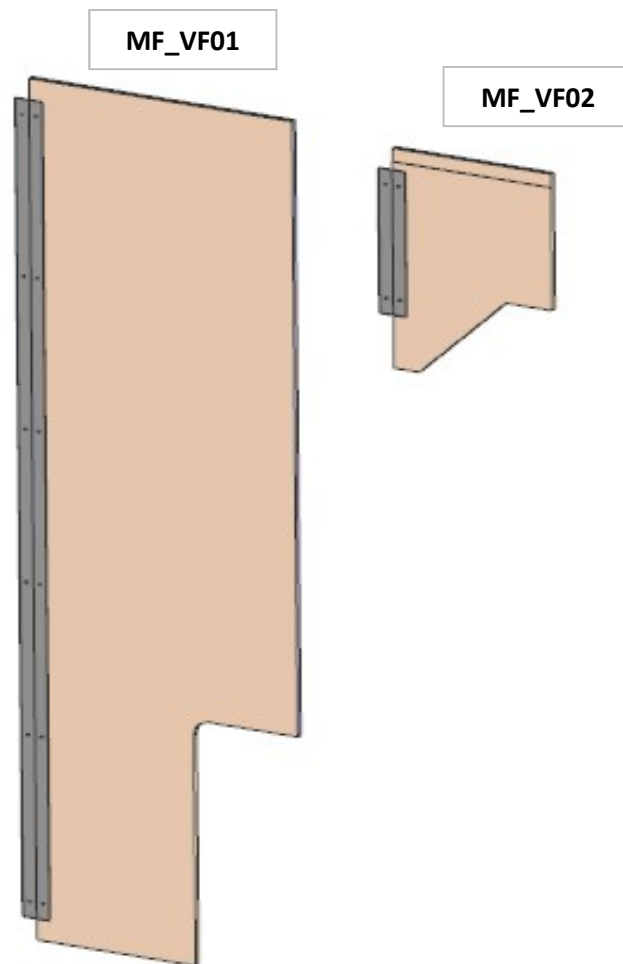

MOD AZ 216
ALLUNGATO RIVESTIMENTI VERSO
PAVIMENTO E RIMOSSI TUTTI I
LAMINATI NERI ALLA BASE DEI
RIVESTIMENTI

AZ26M

MOD DA GR9

REV. GR 9

LOCALE	CODICE	DESCRIZIONE COMPONENTE	FINITURA	Q.TA	OPERATORE
CABINA VIP DX	AZ26M-L01_VF01	RIVESTIMENTO PARETI POPPA	LACCATO BIANCO RAL 9010	2	Damiano

1 - L 486 x H 1624 x sp 10
2 - L 293 x H 414 x sp 10

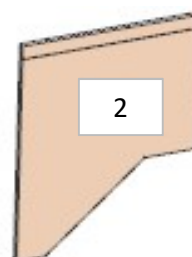
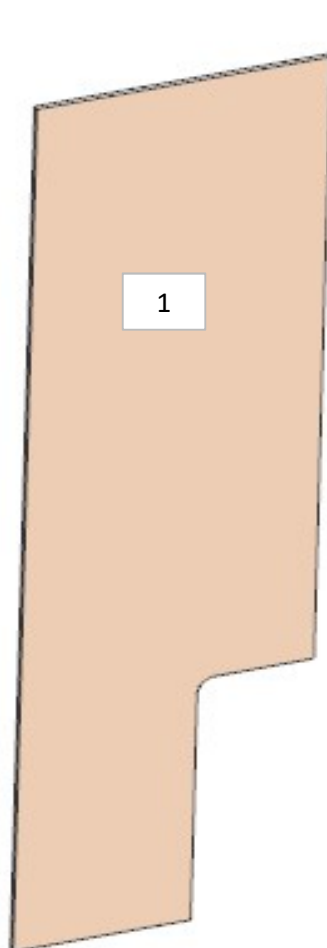

ELEMENTO DA MONTARE con:
A01_VF01
e spedire con un unico imballo

MOD AZ 216
ALLUNGATO RIVESTIMENTI VERSO PAVIMENTO E RIMOSSI TUTTI I LAMINATI NERI ALLA BASE DEI RIVESTIMENTI

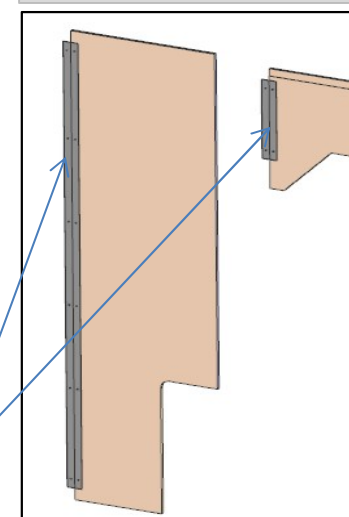

A01_VF01

AZ26M

MOD DA GR9

REV. GR 9

LOCALE	CODICE	DESCRIZIONE COMPONENTE	FINITURA	Q.TA	OPERATORE
CABINA VIP DX	AZ26M-A01_VF01	RIVESTIMENTO PARETI POPPA	ALLUMINIO	2	Damiano

1 - L 50 x H 1543 x sp 2
2 - L 50 x H 274 x sp 2



ELEMENTO DA MONTARE con:
L01_VF01
e spedire con un unico imballo

MOD AZ 216
ALLUNGATO RIVESTIMENTI VERSO
PAVIMENTO E RIMOSI TUTTI I
LAMINATI NERI ALLA BASE DEI
RIVESTIMENTI

L01_VF01

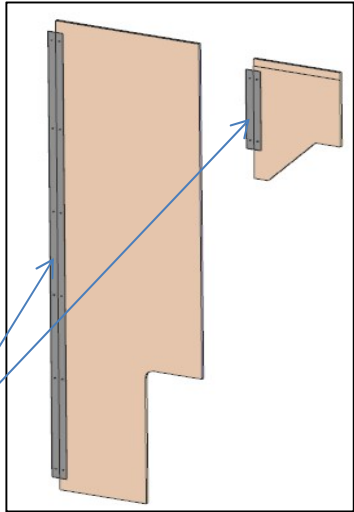

AZ26M

REV. GR 9

LOCALE	CODICE	DESCRIZIONE COMPONENTE	FINITURA	Q.TA	OPERATORE
CABINA VIP DX	AZ26M-A02_VF01	RIVESTIMENTO PARETI POPPA	ACCIAIO NERO	2	Damiano

1 - SVILUPPO L. 995 x H.30 x sp 8
2 - SVILUPPO L. 209 x H.30 x sp 8

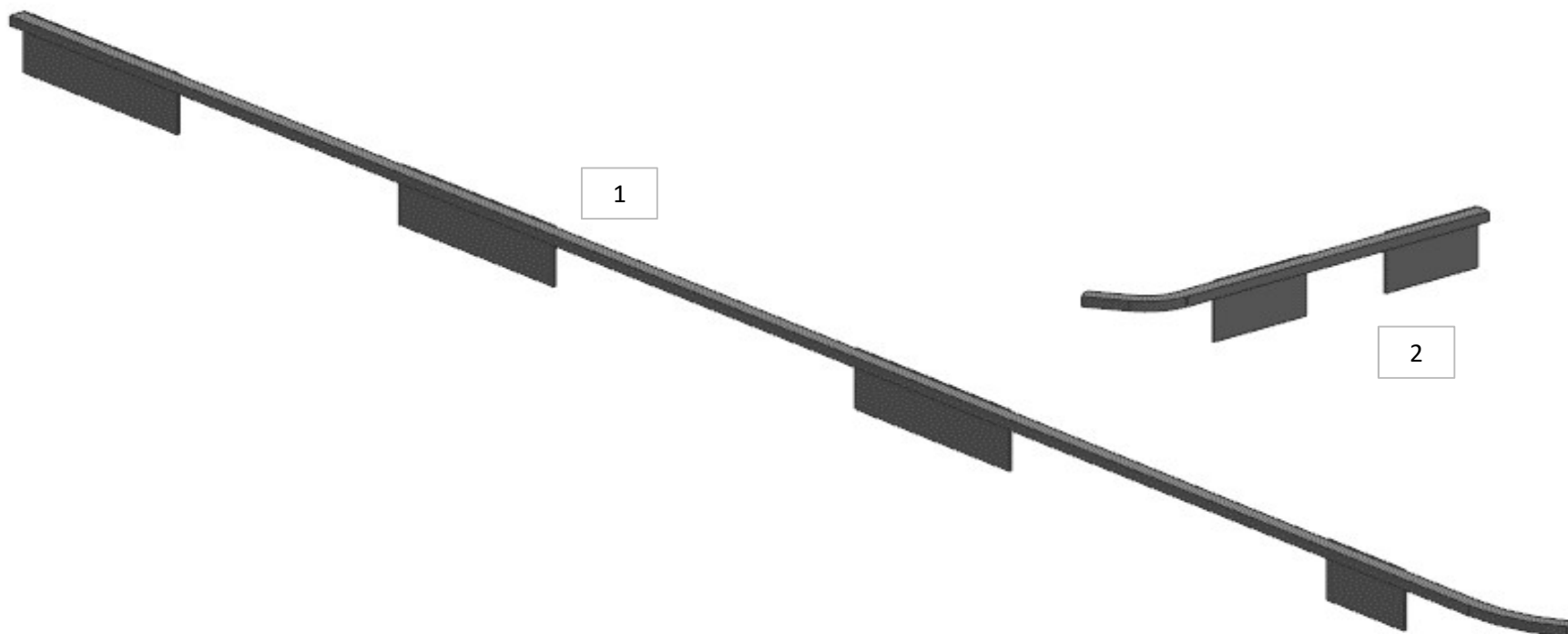

AZ26M

MOD GR10

REV. GR 10

LOCALE	CODICE	DESCRIZIONE COMPONENTE	FINITURA	Q.TA	OPERATORE
CABINA VIP DX	AZ26M-MG_VG01/02	RIVESTIMENTO PARETI CENTRO NAVE		2	Damiano

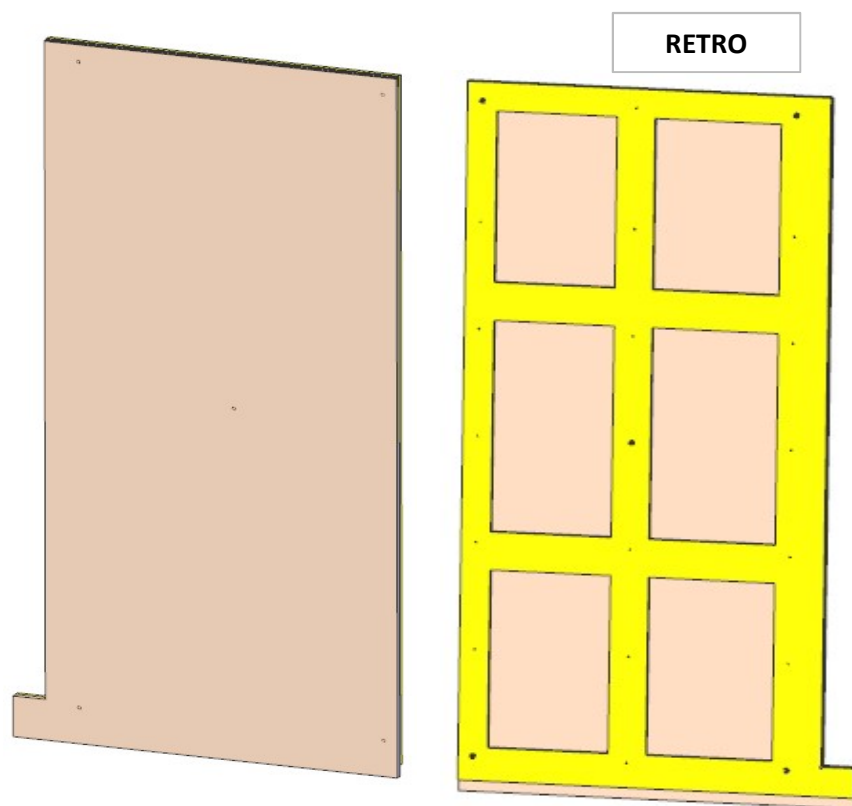

MG_VG01

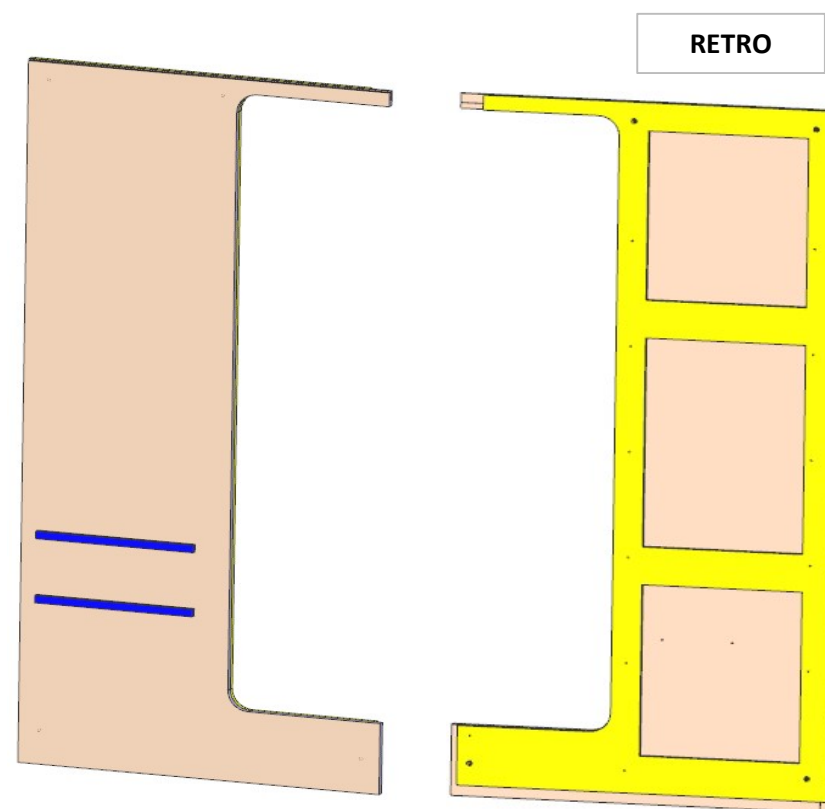

MG_VG02

AZ26M

MOD GR10

REV. GR 10

LOCALE	CODICE	DESCRIZIONE COMPONENTE	FINITURA	Q.TA	OPERATORE
CABINA VIP DX	AZ26M-L01_VG01	RIVESTIMENTO PARETI CENTRO NAVE	LACCATO BIANCO RAL 9010	8	Damiano

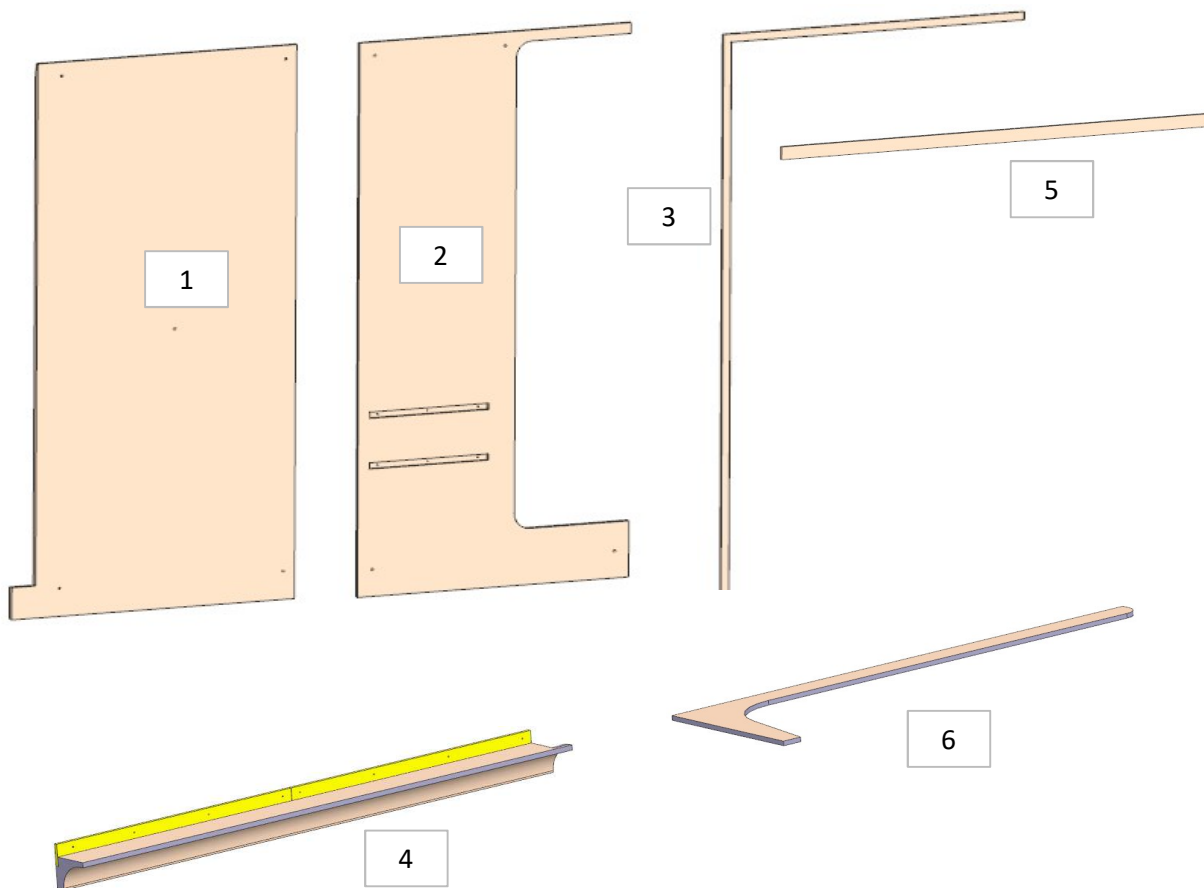

ELEMENTO DA MONTARE con:
MG_VG01
MG_VG02
e spedire con un unico imballo

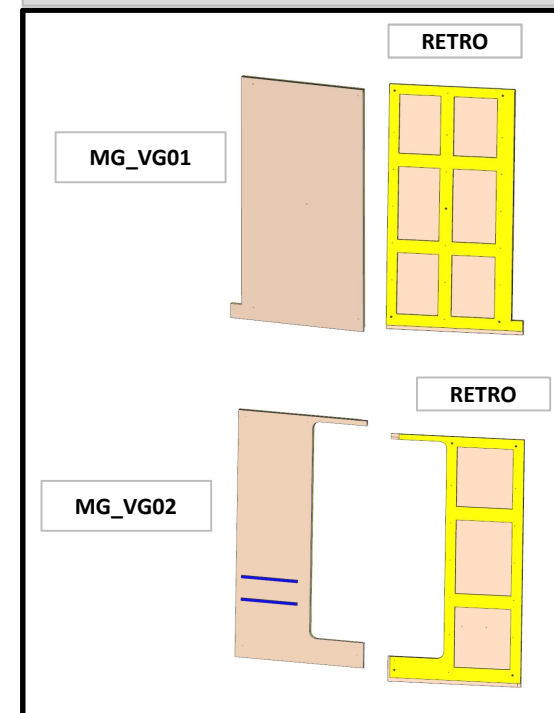

AZ26M

MOD DA GR9

REV. GR 9

LOCALE	CODICE	DESCRIZIONE COMPONENTE	FINITURA	Q.TA	OPERATORE
CABINA VIP DX	AZ26M-R01_VG01	RIVESTIMENTO PARETI CENTRO NAVE	LASTRA CHIARA	4	Damiano

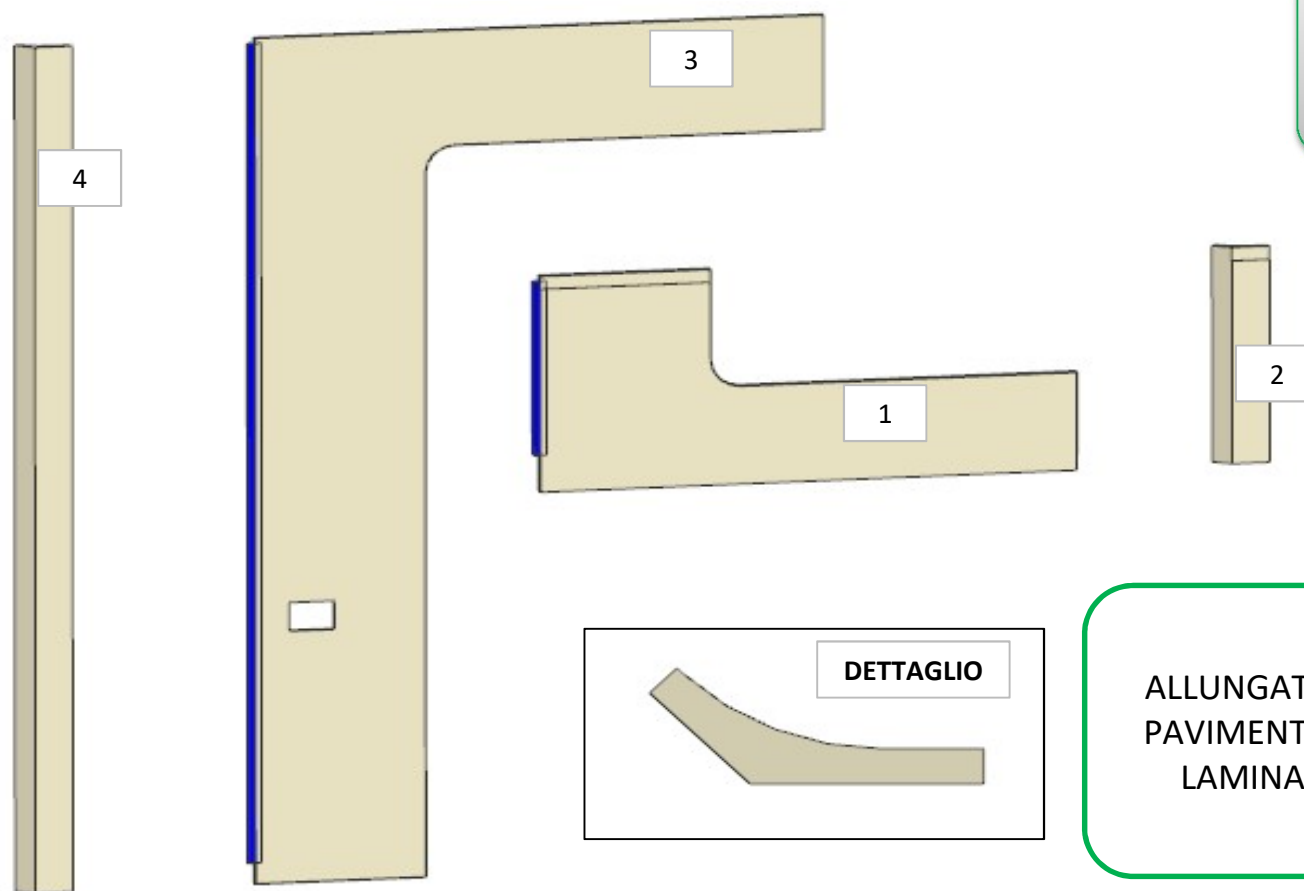

- 1 - L.942 x H.415 x sp 11
- 2 - L.106 x H.415 x sp 11
- 3 - L.996 x H.1624 x sp 11
- 4 - L.106 x H. 1624 x sp 11

MOD AZ 216
ALLUNGATO RIVESTIMENTI VERSO
PAVIMENTO ED ELIMINATO TUTTI I
LAMINATI NERI ALLA BASE DEI
RIVESTIMENTI

AZ26M

REV. GR 9

LOCALE	CODICE	DESCRIZIONE COMPONENTE	FINITURA	Q.TA	OPERATORE
CABINA VIP DX	AZ26M-A01_VG01	RIVESTIMENTO PARETI CENTRO NAVE	ACCIAIO NERO	1	Damiano

1 - L..365 x H..30 x sp 8

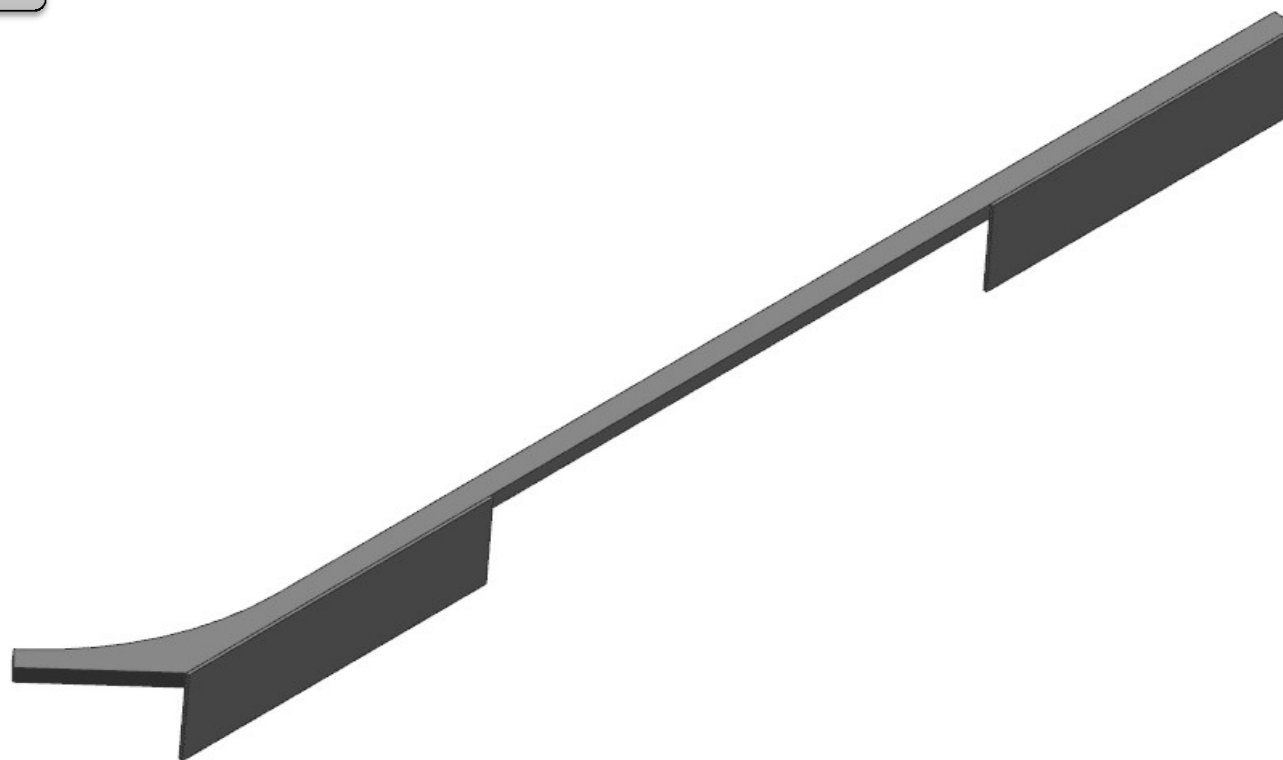

AZ26M

MOD DA GR5

REV. GR 9

LOCALE	CODICE	DESCRIZIONE COMPONENTE	FINITURA	Q.TA	OPERATORE
CABINA VIP DX	AZ26M-MG_VN01	PLENUM ARMADIO	LACCATO BRONZO	1	Damiano

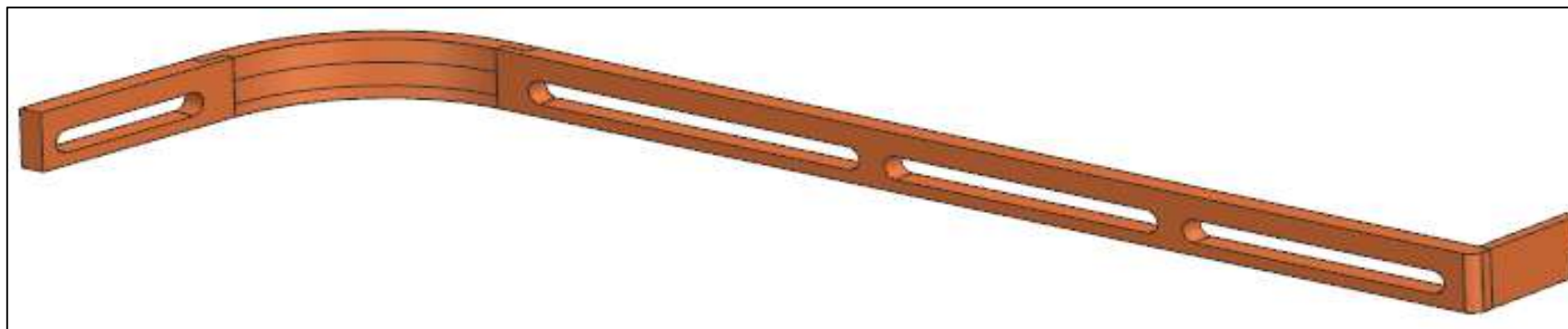

AZ26M

MOD DA GR5

REV. GR 9

LOCALE	CODICE	DESCRIZIONE COMPONENTE	FINITURA	Q.TA	OPERATORE
CABINA VIP DX	AZ26M-L01_VN01	PLENUM ARMADIO	LACCATO BRONZO	4	Damiano

PER LUCIDATURA:
VERIFICARE SE LATO BELLO
LASTRATO

2

**MOD.230 DA GR.5
- MASCHERINA PLENUM
SCOMPOSTA IN 4 PEZZI.
COSEGNARE DIVISI.**

RIMOSSO IL 'MONTATO FINITO'

**ELEMENTO DA MONTARE:
MG_VN01
e spedire con un unico imballo**

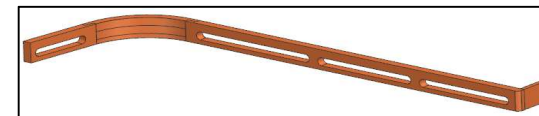

1

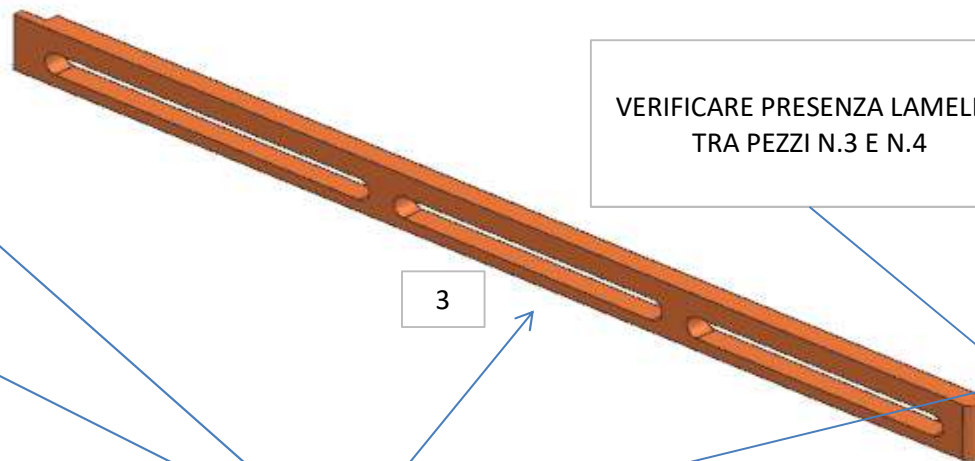
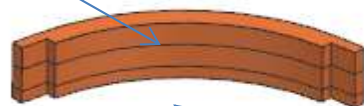

3

VERIFICARE PRESENZA LAMELLO
TRA PEZZI N.3 E N.4

4

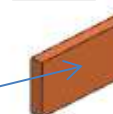

- 1 - L.282 x H 76 x sp 30
- 2 - SVILUPPO 312 x H 76 x sp 30
- 3 - L.1383 x H 76 x sp 30
- 4 - L.150 x H 76 x sp 30

PER LUCIDATURA:
1 LATO BELLO + TUTTI I FILI - LUCIDARE BENE INERNO ASOLE

consonni&c

AZ26M

REV. GR 9

LOCALE	CODICE	DESCRIZIONE COMPONENTE	FINITURA	Q.TA	OPERATORE
BAGNO VIP DX	AZ26M-L01_JA01	STRUTTURA MURATA DOCCIA	LACCATO BIANCO RAL 9010	6	Damiano

- 1 - L 1199 x H.1570 x sp 16
- 2 - L 765 x H.484 x sp 16
- 3 - L 961 x H.243 x sp 10
- 4 - L 833 x H.243 x sp 10
- 5 - L 795 x H 239 x sp 10
- 6 - L 960 x H 188 x sp 10

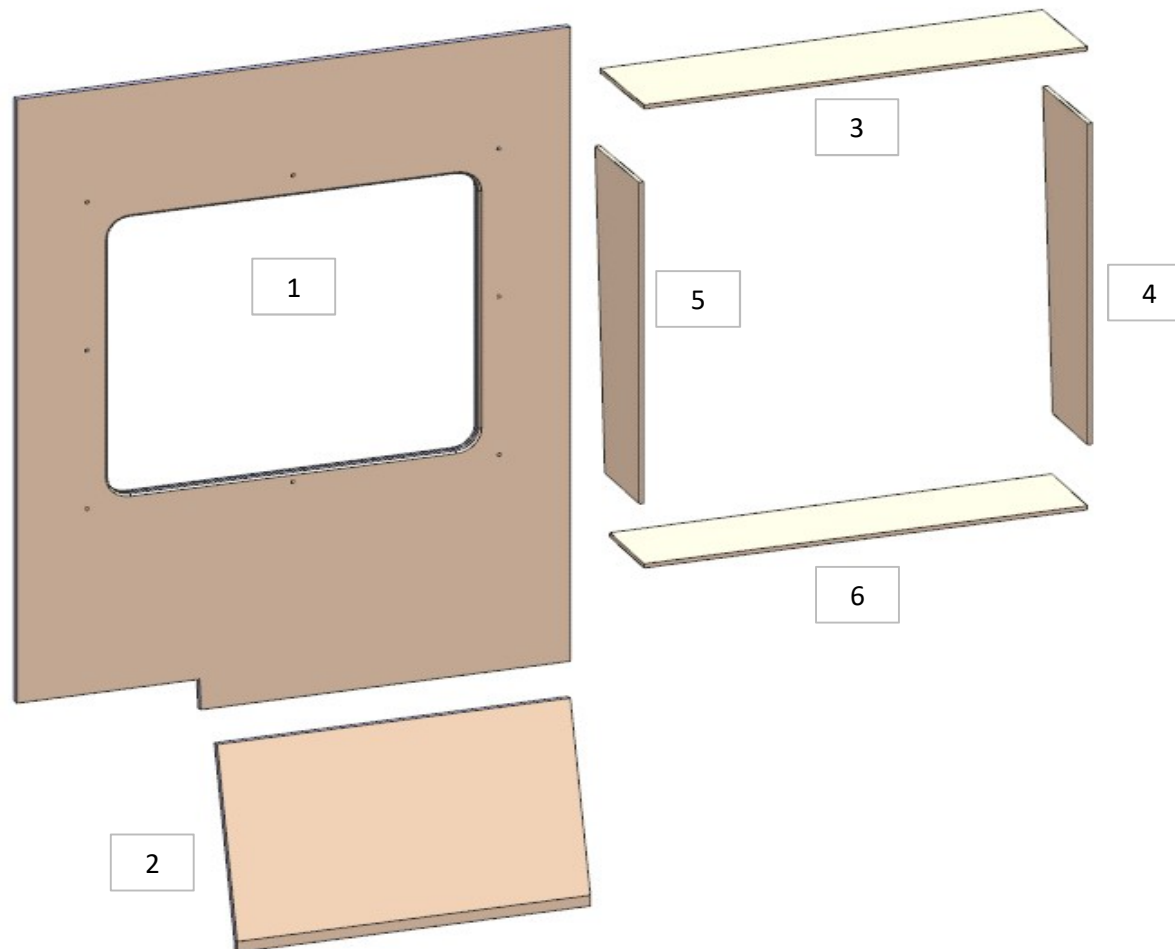

AZ26M

REV. GR 9

LOCALE	CODICE	DESCRIZIONE COMPONENTE	FINITURA	Q.TA	OPERATORE
BAGNO VIP DX	AZ26M-L01_JB01	RIVESTIMENTI PARETI DOCCIA	LACCATO BIANCO RAL 9010	6	Damiano

- 1 - L 628 x H 2043 x sp 10
- 2 - sviluppo L 309 x H 2043 x sp 10
- 3 - L 817 x H 104 x sp 10
- 4 - L 839 x H 41 x sp 10
- 5 - L 260 x H 1494 x sp 10
- 6 - L 631 x H 1494 x sp 10

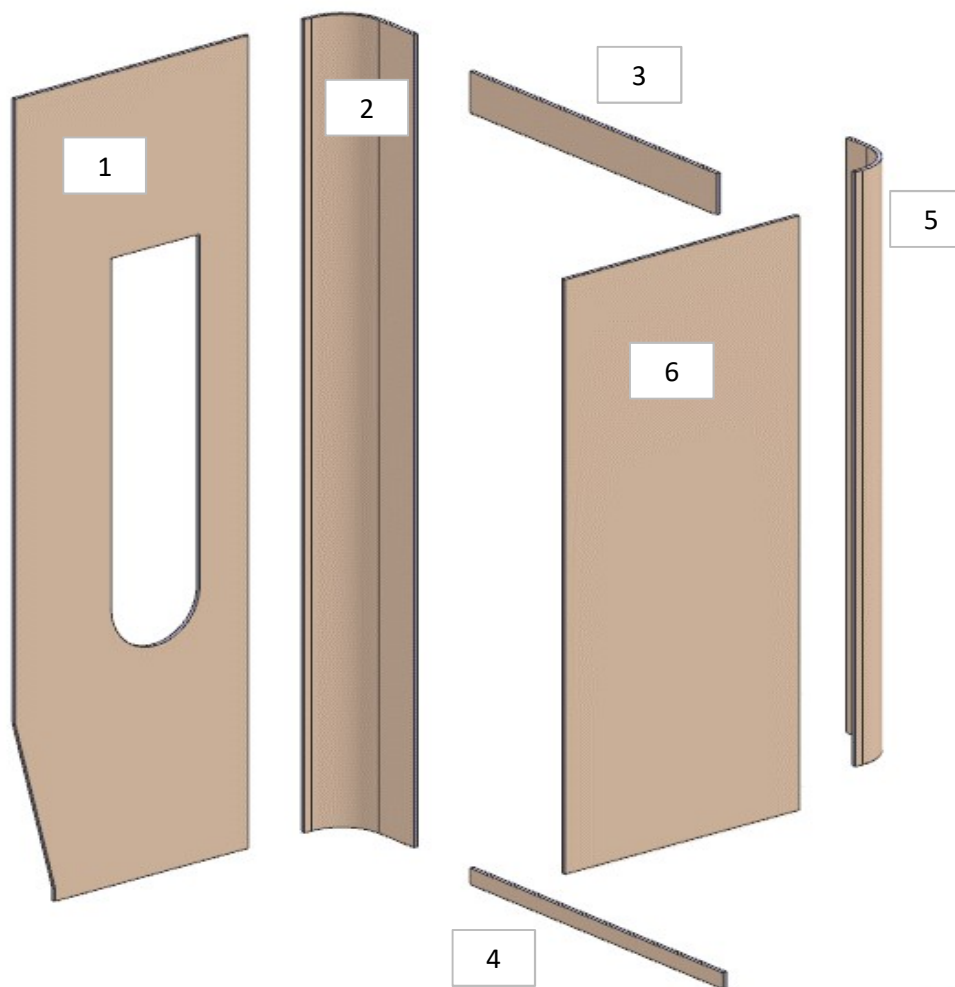

AZ26M

REV. GR 9

LOCALE	CODICE	DESCRIZIONE COMPONENTE	FINITURA	Q.TA	OPERATORE
BAGNO VIP DX	AZ26M-R01_JH01	RIV. PARETI INGRESSO BAGNO	LASTRA CHIARA	4	Damiano

- 1 - L.106 x H.2029 x sp 11
- 2 - L.71 x H.2029 x 71
- 3 - L.518 x H.2029 x sp 11
- 4 - L.429 x H.2029 x sp 11

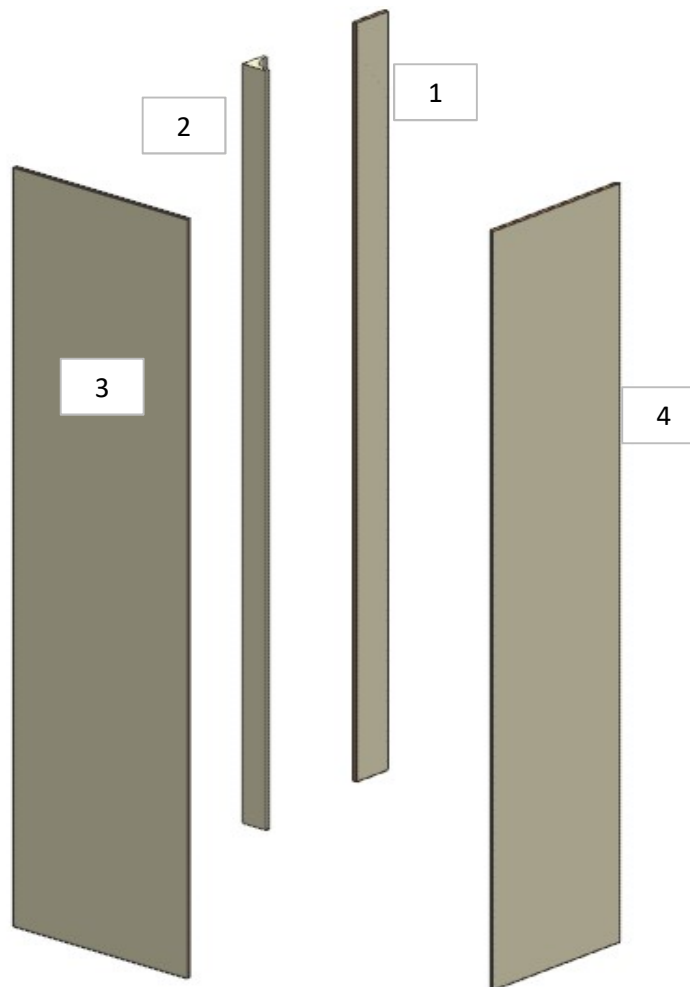

AZ26M

REV. GR 9

LOCALE	CODICE	DESCRIZIONE COMPONENTE	FINITURA	Q.TA	OPERATORE
BAGNO VIP DX	AZ26M-L01_JH01	RIV. PARETI INGRESSO BAGNO	LACCATO BIANCO RAL 9010	7	Damiano

- 1 - L.817 x H.94 x sp 10
- 2 - L.817 x H 25 x sp 10
- 3 - L.268 x H.2029 x sp 10
- 4- L. 69 x H 1183 x 69
- 5 - L.1012 x H.1183 x sp 10
- 6 - L.69 x H. 1183 x 60
- 7 - L 451 x H.2029 x sp 10

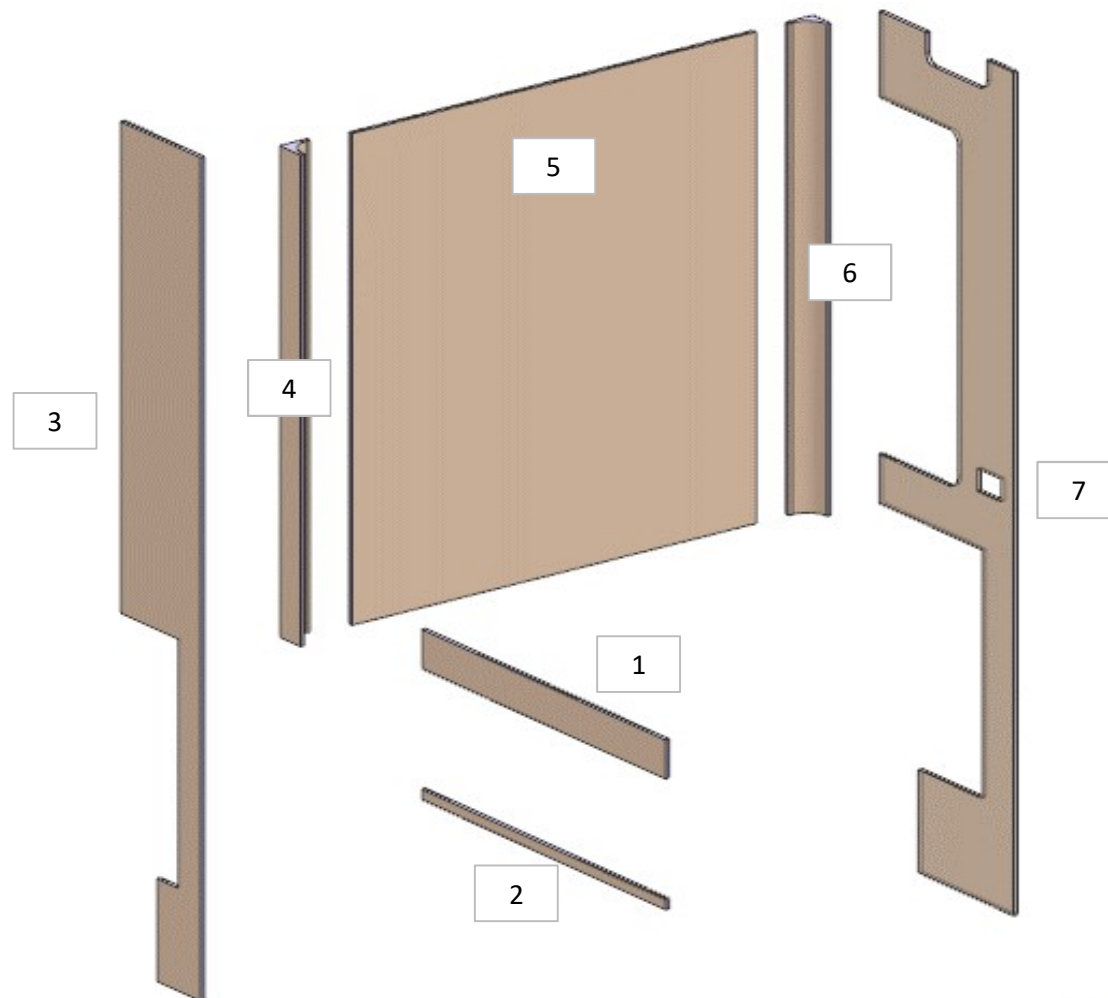

AZ26M

MOD DA GR4/5

REV. GR 9

LOCALE	CODICE	DESCRIZIONE COMPONENTE	FINITURA	Q.TA	OPERATORE
BAGNO VIP DX	AZ26M-MF_JI01	MOBILE LAVELLO			Damiano

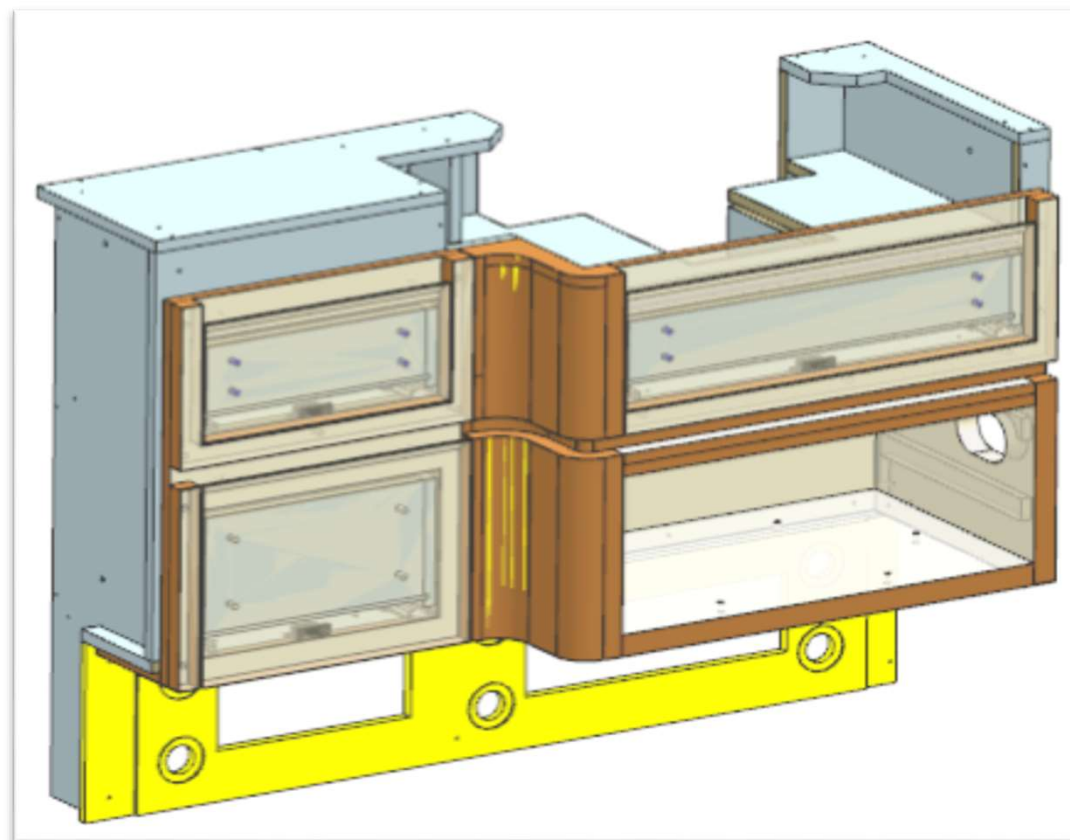

FERRAMENTA:

- N° 1 - GUIDA 350
- N° 2 - GUIDA 250
- N° 3 - CALAMITA PER CASSETTI
- N° 6 - FITLOCK MASCHIO
- N° 6 - FITLOCK FEMMINA
- N° 29 - VITI 6MA
- N° 25 - BUSSOLA ZAMA 6MA
- N° 62 - SPINA diam 8

AZ26M

MOD DA GR5

REV. GR 9

LOCALE	CODICE	DESCRIZIONE COMPONENTE	FINITURA	Q.TA	OPERATORE
BAGNO VIP DX	AZ26M-JI01	MOBILE LAVELLO	NADIR \ OKOUME' GREZZO	1	Damiano

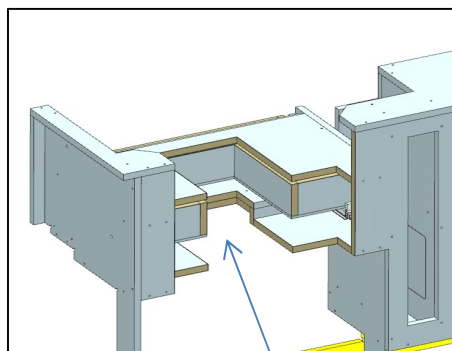

DETTAGLIO MODIFICA
SUL RETRO MOBILE

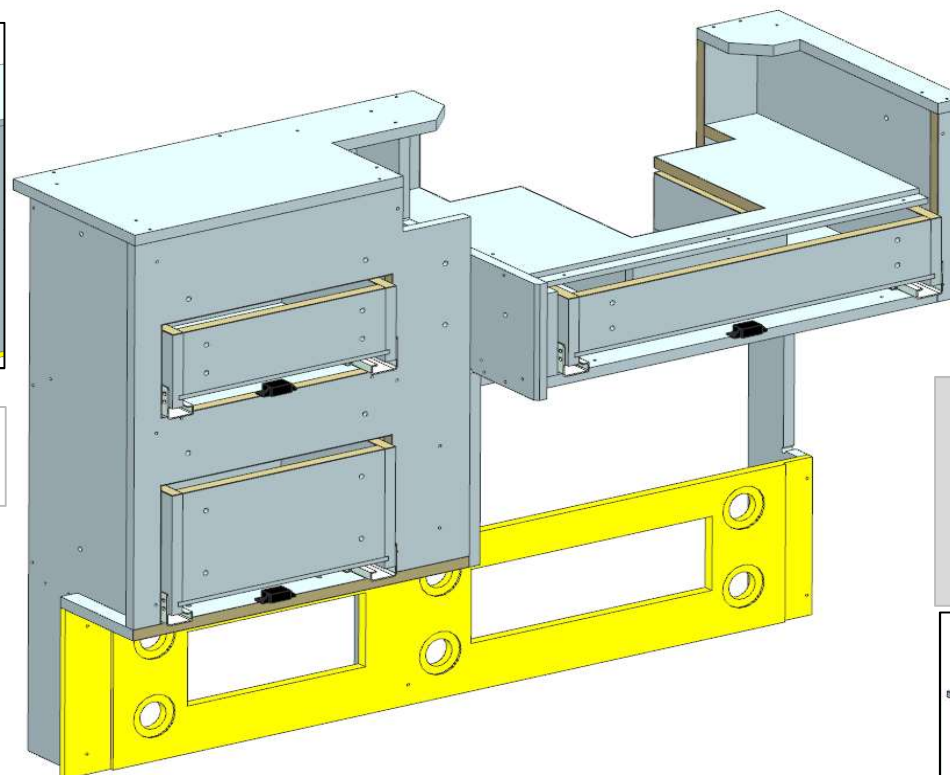

MOD.147 DA GR.5 -
REALIZZATO SCASSO
PER SIFONE

ELEMENTO DA MONTARE con:
R01_JI01
L01_JI01
e spedire con un unico imballo

FERRAMENTA:

- N° 1 - GUIDA 350
- N° 2 - GUIDA 250
- N° 3 - CALAMITA PER CASSETTI
- N° 6 - FITLOCK MASCHIO
- N° 6 - FITLOCK FEMMINA
- N° 29 - VITI 6MA
- N° 25 - BUSSOLA ZAMA 6MA
- N° 62 - SPINA diam 8

R01_JI01

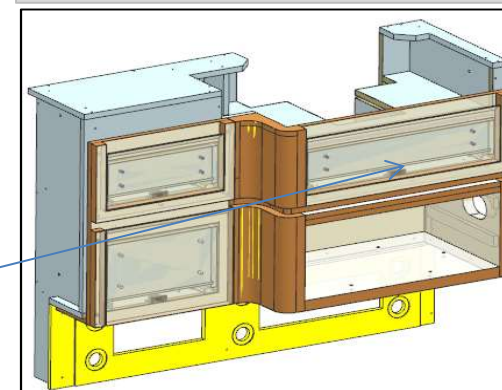

consonni&c

AZ26M

MOD DA GR4/5

REV. GR 9

LOCALE	CODICE	DESCRIZIONE COMPONENTE	FINITURA	Q.TA	OPERATORE
BAGNO VIP DX	AZ26M-R01_JI01	MOBILE LAVELLO	LASTRA CHIARA	15	Damiano

- 2 - L 510 x H 142 x sp 16
- 3 - L 342 x H 163 x sp 25
- 4 - L 372 x H 279 x sp 25
- 7 - L 721 x H 159 x sp 25

MODIFICATA SAGOMA DA GR5

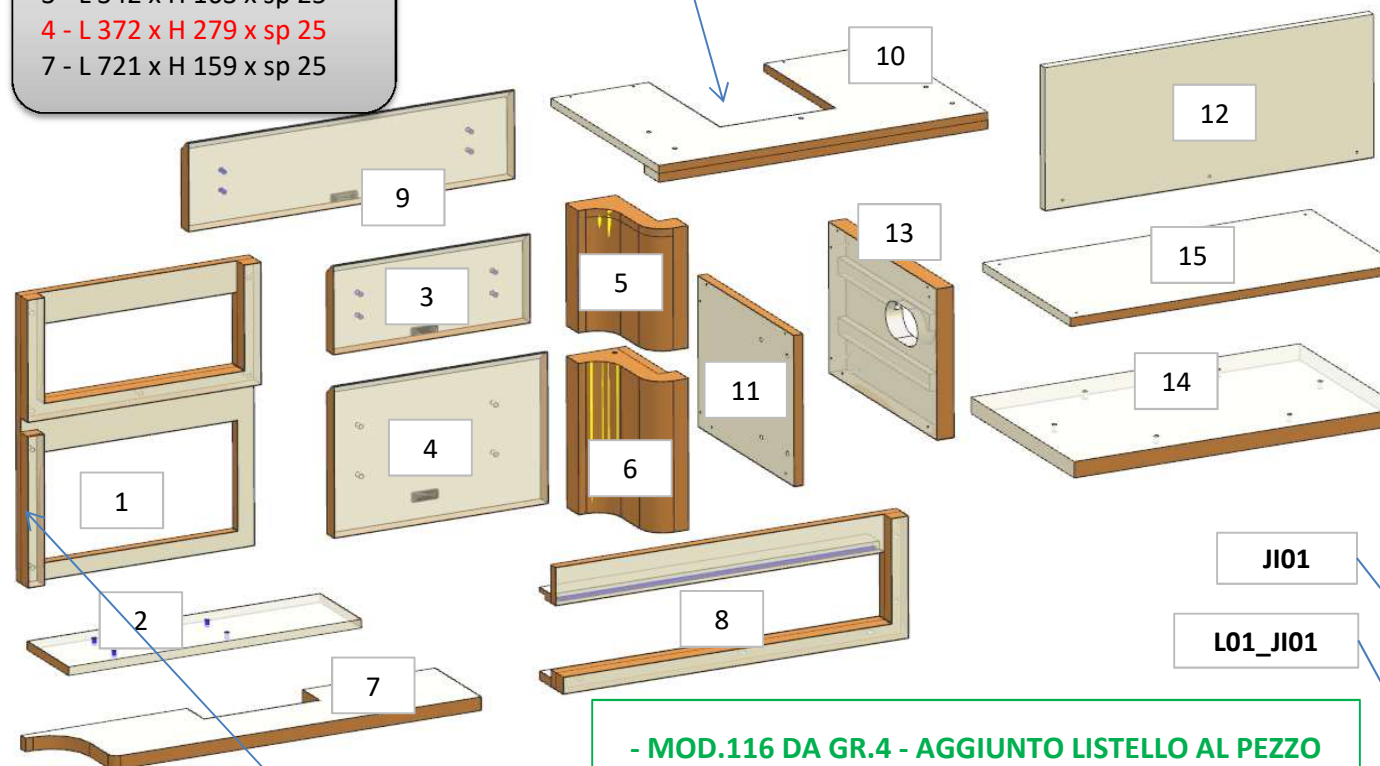

AGGIUNTO LISTELLO DA GR4

- MOD.116 DA GR.4 - AGGIUNTO LISTELLO AL PEZZO N.1 E MODIFICATE DIMENSIONI PEZZO N.4
- MOD.147 DA GR.5 - MODIFICATA SAGOMA PEZZO N.10 E AGGIUNTO PEZZO N.15

- 9 - L 657 x H 163 x sp 25
- 10 - L 571 x H 371 x sp 31
- 11 - L 330 x H 279 x sp 16
- 12 - L 571 x H 264 x sp 16
- 13 - L 371 x H 279 x sp 30
- 14 - L 571 x H 355 x sp 30
- 15 - L 572 x H 303 x sp 16

ELEMENTO DA MONTARE con:
JI01
L01_JI01
 e spedire con un unico imballo

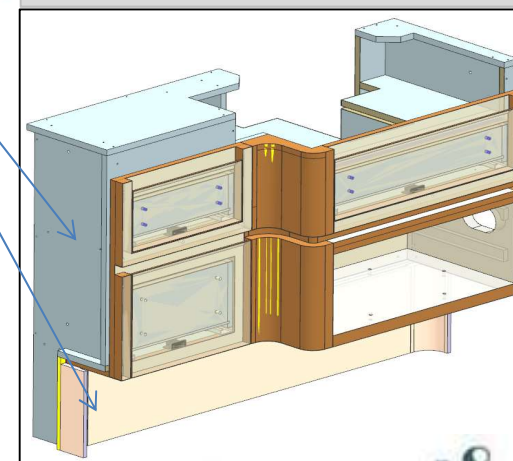

consonni&c

AZ26M

REV. GR 9

LOCALE	CODICE	DESCRIZIONE COMPONENTE	FINITURA	Q.TA	OPERATORE
BAGNO VIP DX	AZ26M-L01_JI01	MOBILE LAVELLO	LACCATO BIANCO RAL 9010	3	Damiano

1 - 3 - L. 69 x H.231 x sp 77
2 - L. 1011 x H.231 x sp 10

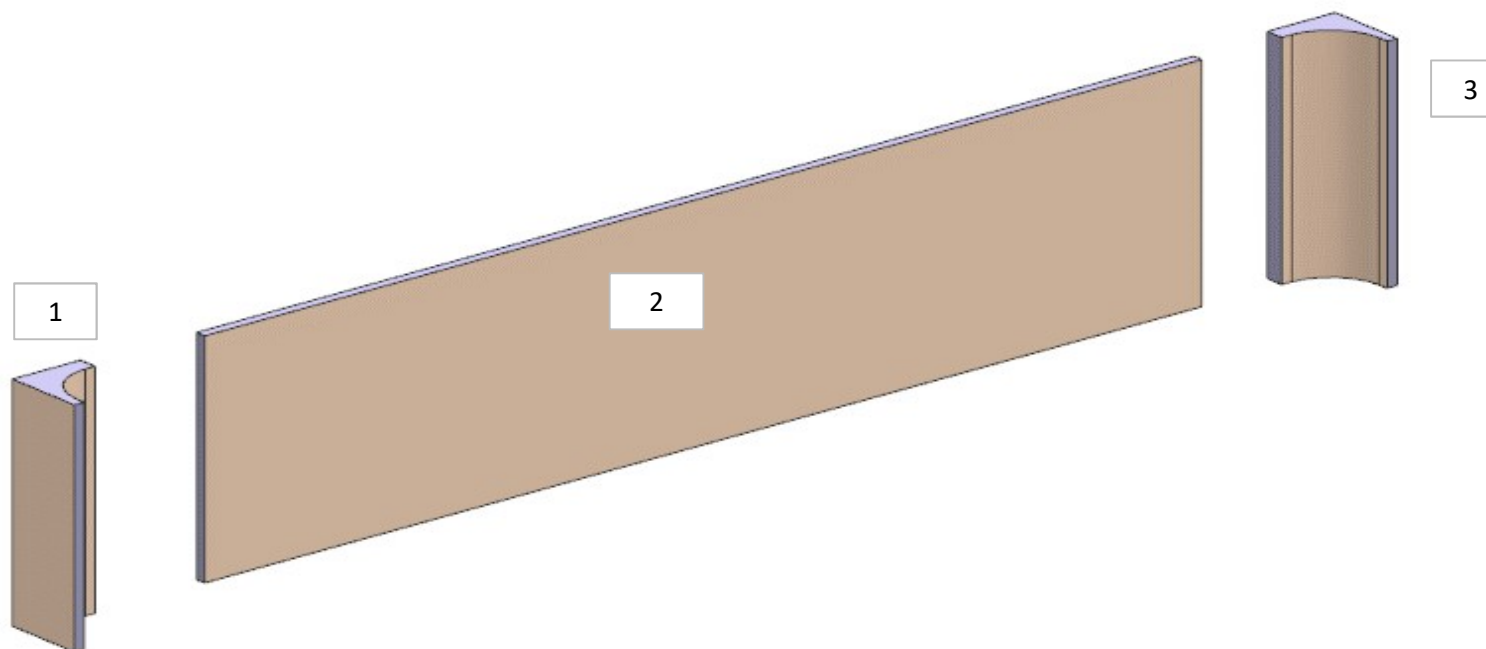

AZ26M

REV. 01-2023

REV. GR 9

LOCALE	CODICE	DESCRIZIONE COMPONENTE	FINITURA	Q.TA	OPERATORE
BAGNO VIP DX	AZ26M-MG_JN01	NICCHIA LATERALE LAVABO			Damiano

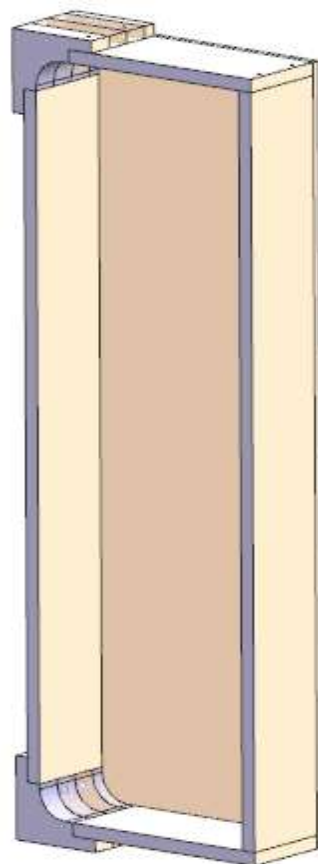

AZ26M

REV. 01-2023

REV. GR 10

LOCALE	CODICE	DESCRIZIONE COMPONENTE	FINITURA	Q.TA	OPERATORE
BAGNO VIP DX	AZ26M-L01_JN01	NICCHIA LATERALE LAVABO	LACCATO BIANCO RAL 9010	2	Damiano

1 - L.333 x H 974 x sp 16
2 - L.302 x H 944 x 106

**MODIFICATO METODO
DI MONTAGGIO**

FERRAMENTA:

N° 12 - SPINA diam 8
N° 4 - BUSSOLA ZAMA 6MA
N° 4 - VITI 6MA

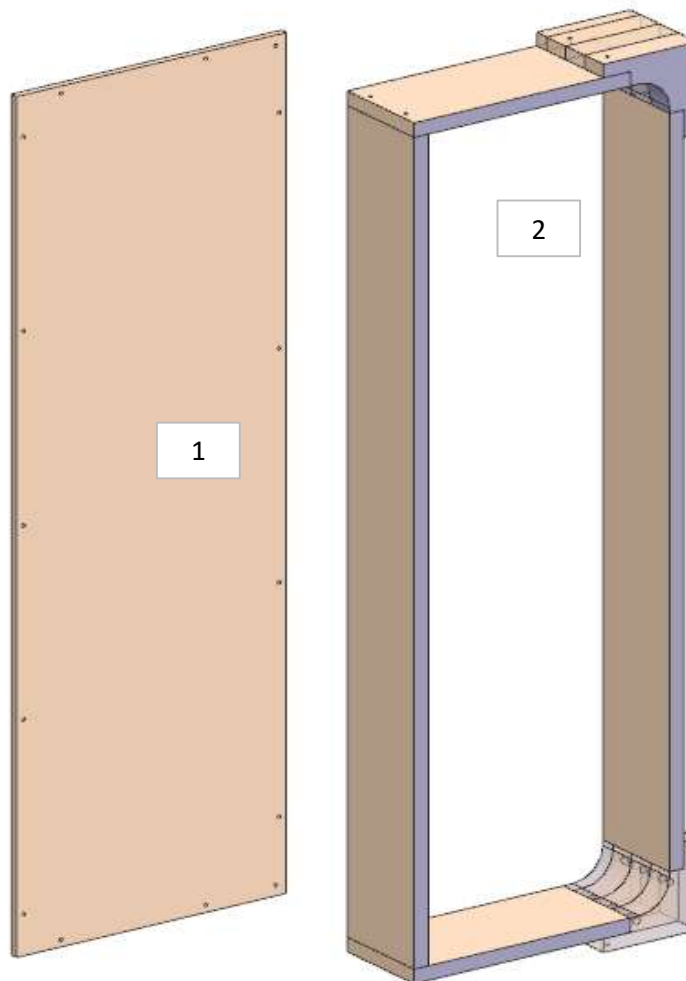

**ELEMENTO DA
MONTARE con:
L01_JN01
e spedire con un
unico imballo**

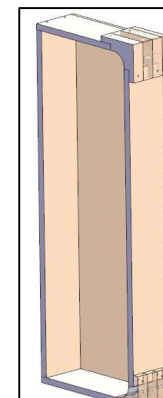

consonni&c

AZ26M

MOD DA GR2

REV. GR 9

LOCALE	CODICE	DESCRIZIONE COMPONENTE	FINITURA	Q.TA	OPERATORE
BAGNO VIP DX	AZ26M-X01_JQ01	CONTENITORE PORTA SAPONE	LAMINATO NERO	1	Damiano

1 - L.190 x H 100 x 90

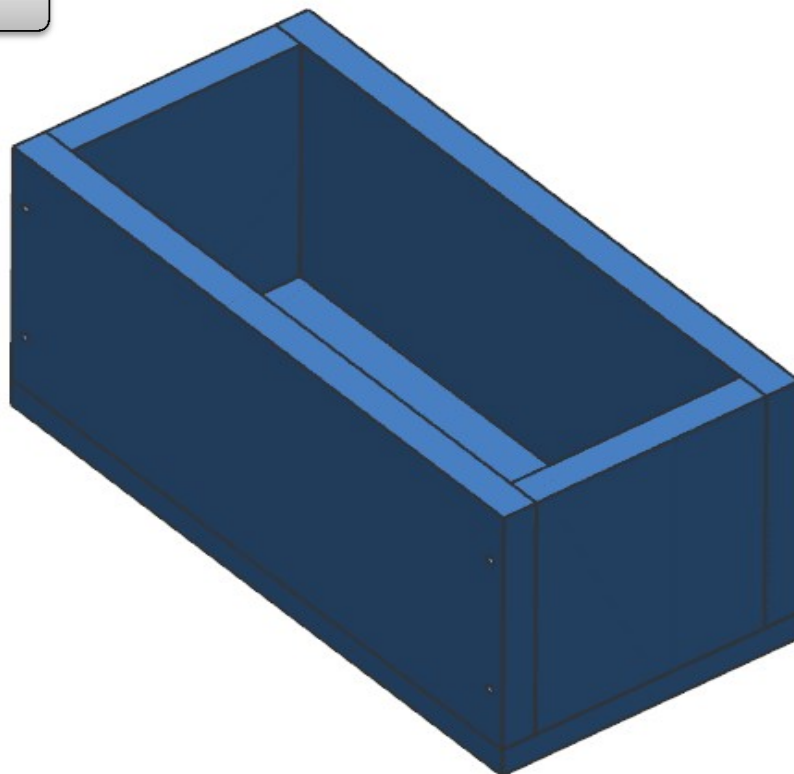

- MOD.138 DA GR.2 - AGGIUNTA
SCATOLA PORTA SAPONE IN
LAMINATO NERO

AZ26M

REV. 01-2023

REV. GR 9

LOCALE	CODICE	DESCRIZIONE COMPONENTE	FINITURA	Q.TA	OPERATORE
CABINA VIP SX	AZ26M-MF_VVA01\ VVA02	STRUTTURA MURATA TESTATA LETTO			Damiano

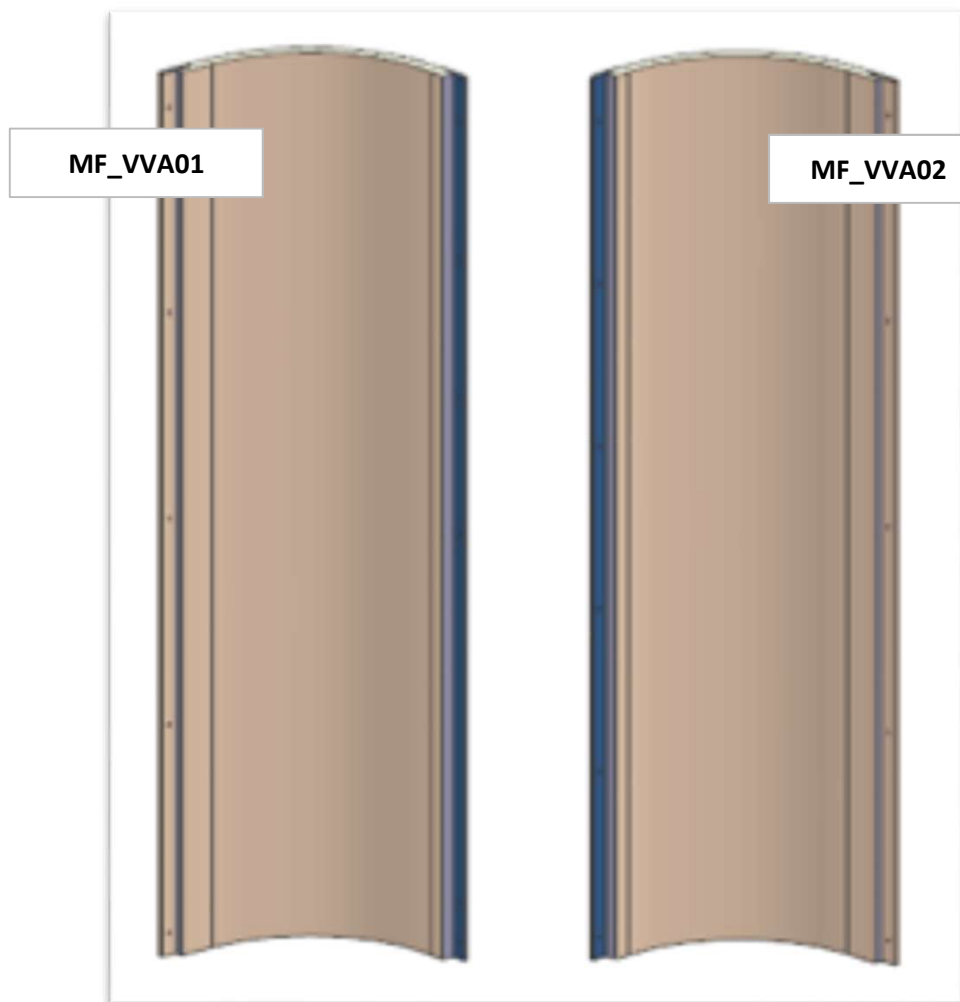

AZ26M

GR5

REV.9

LOCALE	CODICE	DESCRIZIONE COMPONENTE	FINITURA	Q.TA	OPERATORE
CABINA VIP SX	AZ26M-L01_VVA01	STRUTTURA MURATA TESTATA LETTO	LACCATO BIANCO RAL 9010	11	Damiano

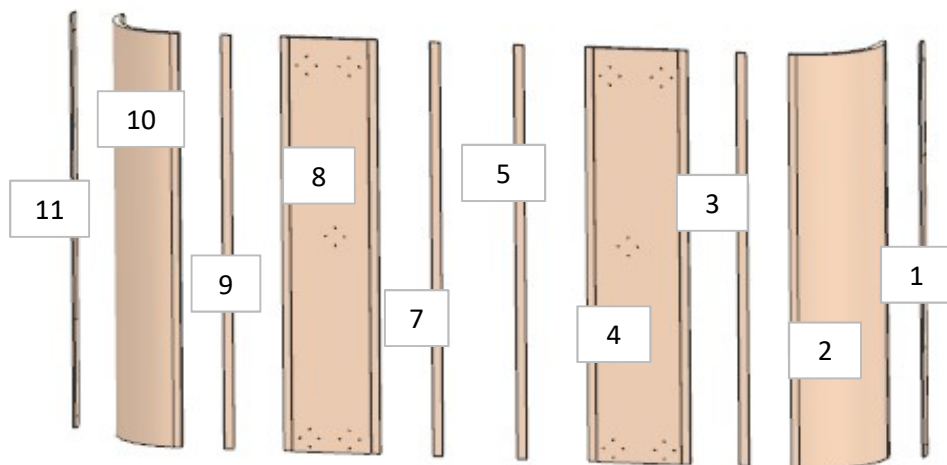

- 1 - 11 - L 40 x H 1160 x sp 6
- 2 - 10 - L 330 x H 1160 x sp 16
- 3 - 5 - 7 - 9 - L 25 x H 1160 x sp 6
- 4 - L 248 x H 1160 x sp 16
- 6 - L 1781 x H 1267 x sp 16
- 8 - L 263 x H 1160 x sp 16

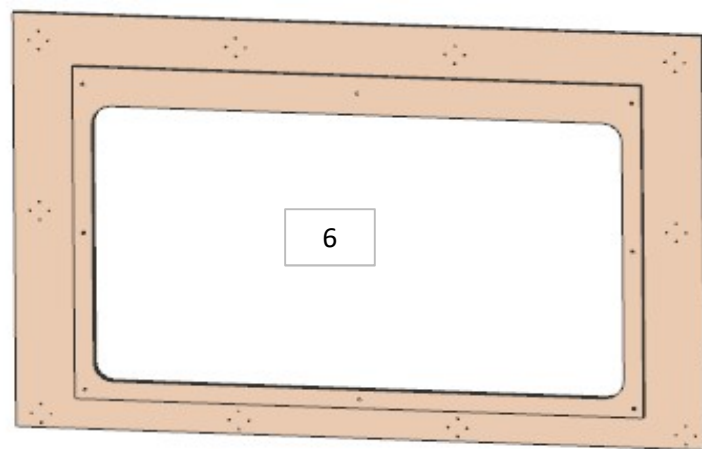

**ELEMENTO DA MONTARE con:
R01_VVA01
e spedire con un unico imballo**

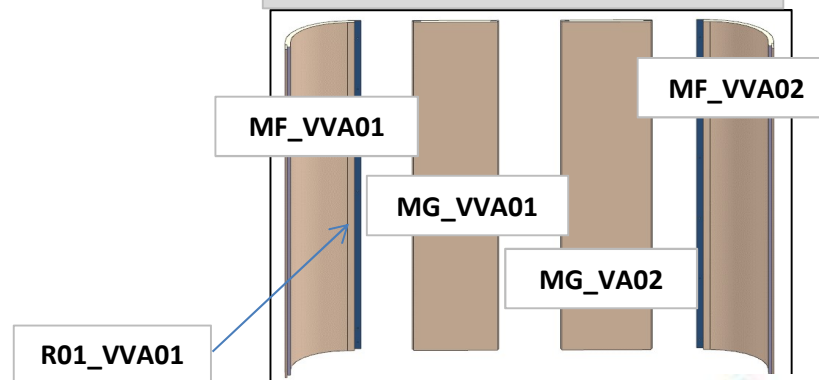

AZ26M

REV. 01-2023

REV. GR 9

LOCALE	CODICE	DESCRIZIONE COMPONENTE	FINITURA	Q.TA	OPERATORE
CABINA VIP SX	AZ26M-X01_VVA01	STRUTTURA MURATA TESTATA LETTO	LAMINATO NERO	2	Damiano

1 - 2 - L 40 x H.1160 x sp 3

1

2

ELEMENTO DA MONTARE con:
X01_VVA01
e spedire con un unico imballo

MOD AZ 216
RIMOSSI LAMINATI ALLA BASE

MF_VVA01

MF_VVA02

consonni&c

AZ26M

REV. GR 9

LOCALE	CODICE	DESCRIZIONE COMPONENTE	FINITURA	Q.TA	OPERATORE
CABINA VIP SX	AZ26M-MG_VVA01\ VVA02	STRUTTURA MURATA TESTATA LETTO		2	Damiano

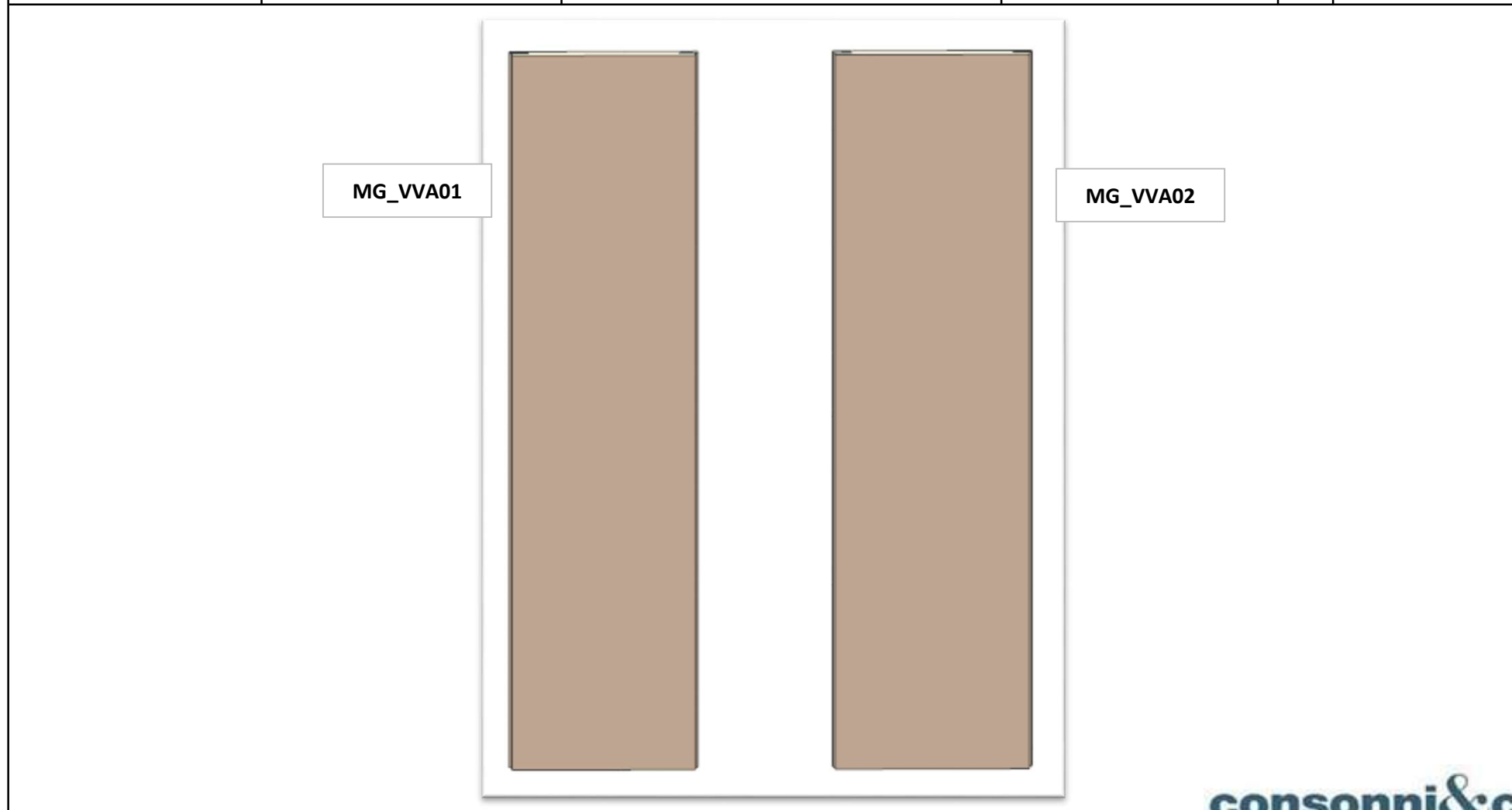

AZ26M

MOD DA GR5

REV.9

LOCALE	CODICE	DESCRIZIONE COMPONENTE	FINITURA	Q.TA	OPERATORE
CABINA VIP SX	AZ26M-L02_VVA01	STRUTTURA MURATA TESTATA LETTO	LACCATO NCS S3020-Y30R	4	Damiano

1 - 3 - L.1451 x H.201 x sp 10
2 - 4 - L. 934 x H.201 x sp 10

**MOD.146 DA GR.5 -
MODIFICATA PROFONDITA'
PANNELLI**

PER LUCIDATURA:
1 LATO BELLO + TUTTI I FILI

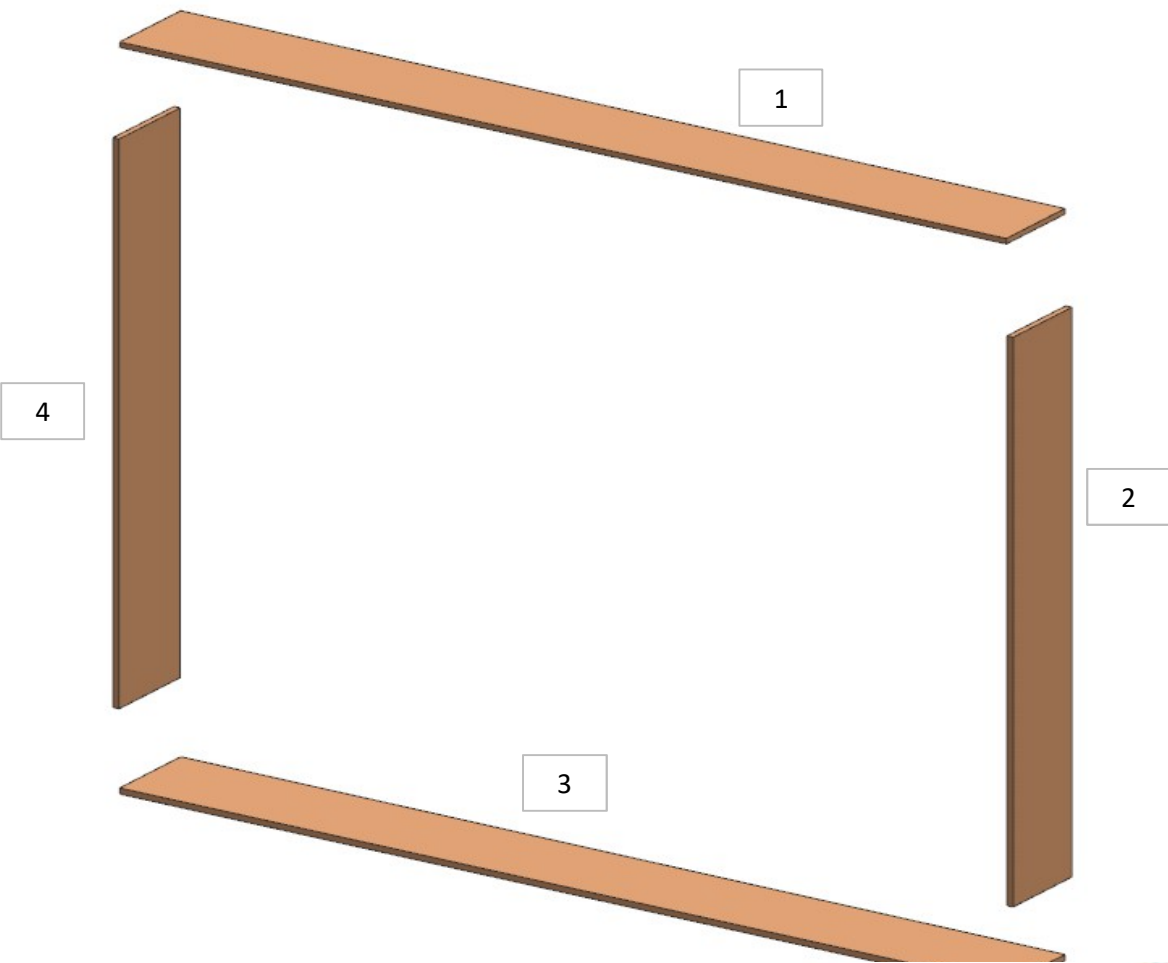

AZ26M

MOD DA GR9

REV. GR 9

LOCALE	CODICE	DESCRIZIONE COMPONENTE	FINITURA	Q.TA	OPERATORE
CABINA VIP SX	AZ26M-R01_VVE01	RIVESTIMENTO PARETI PRUA	LASTRA CHIARA	4	Damiano

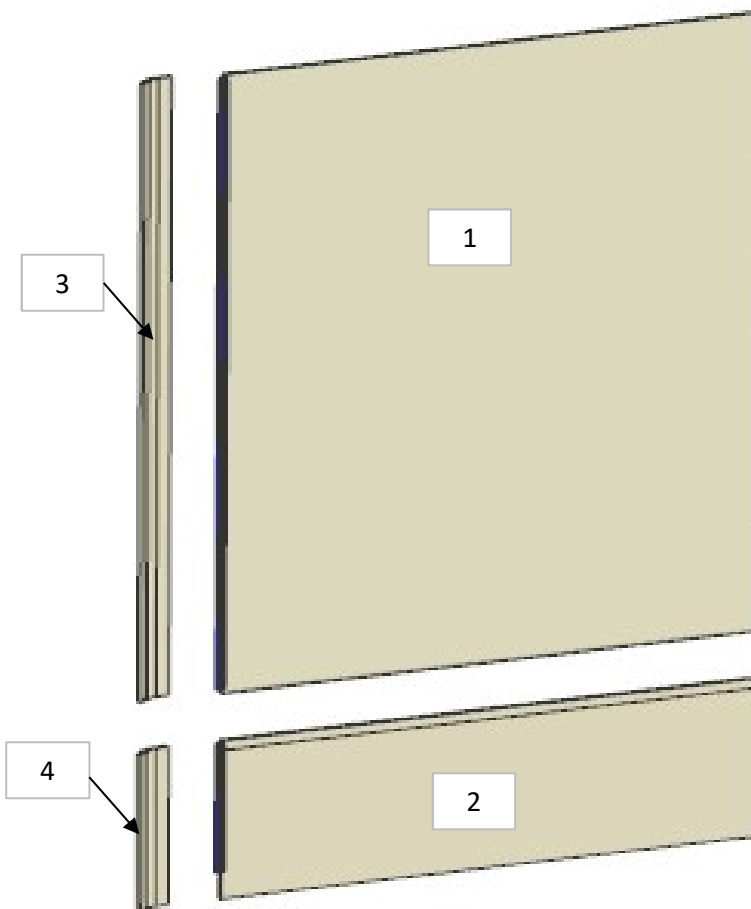

- 1 - SVILUPPO L 1429 x H.1624 x sp. 11
- 2 - SVILUPPO L 1429 x H.414 x sp. 11
- 3 - SVILUPPO L 1429 x H.385 x sp. 11
- 4 - SVILUPPO L 1429 x H.414 x sp. 11

MOD AZ 216
ALLUNGATO
RIVESTIMENTI VERSO
PAVIMENTO ED
ELIMINATO LAMINATI

DETTAGLIO

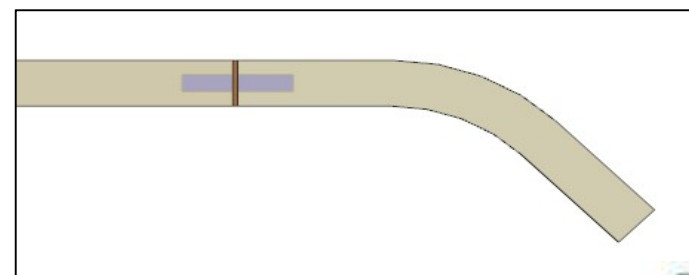

consonni&c

AZ26M

REV. 01-2023

REV. GR 9

LOCALE	CODICE	DESCRIZIONE COMPONENTE	FINITURA	Q.TA	OPERATORE
CABINA VIP SX	AZ26M-MF_VVE01\ VVE02	RIVESTIMENTO PARETI PRUA			Damiano

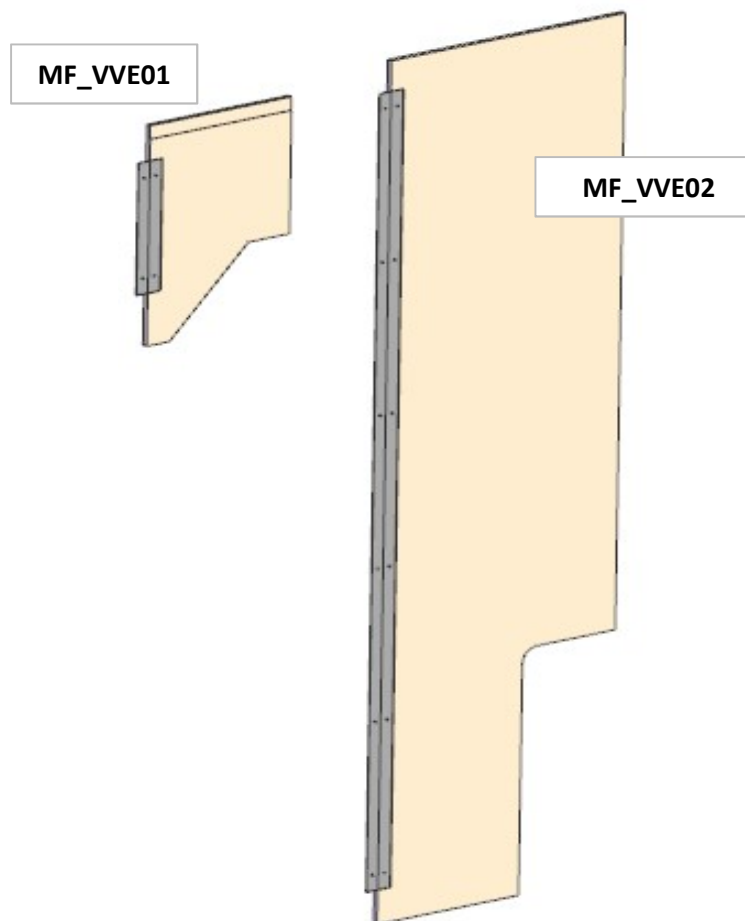

AZ26M

MOD DA GR9

REV.9

LOCALE	CODICE	DESCRIZIONE COMPONENTE	FINITURA	Q.TA	OPERATORE
CABINA VIP SX	AZ26M-L01_VVE01	RIVESTIMENTO PARETI PRUA	LACCATO BIANCO RAL 9010	2	Damiano

1 - L 486 x H 1624 x sp 10
2 - L 293 x H 414 x sp 10

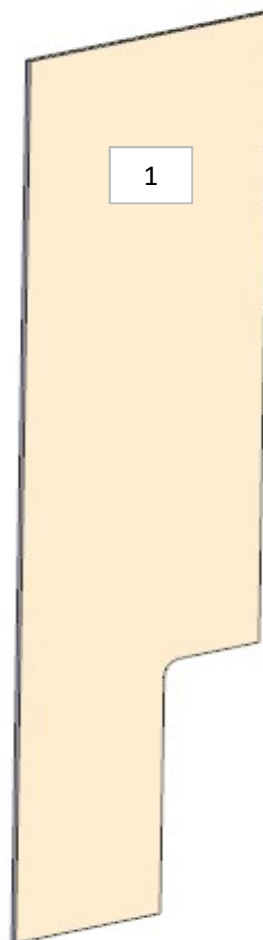
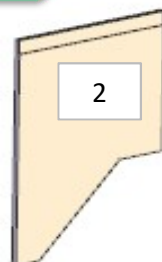

MOD AZ 216
ALLUNGATO
RIVESTIMENTI VERSO
PAVIMENTO ED
ELIMINATO LAMINATI

ELEMENTO DA MONTARE
con:
X01_VVE01
A01_VVE01
e spedire con un unico
imballo

A01_VVE01

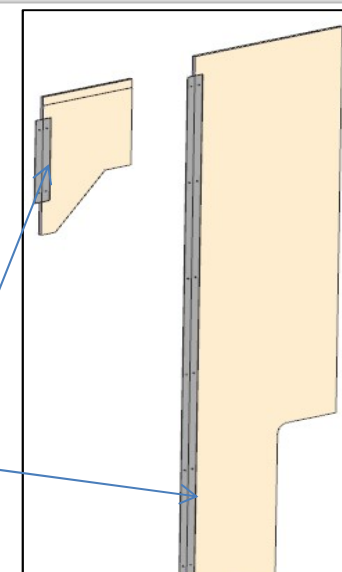

consonni&c

AZ26M

REV. 01-2023

REV. GR 9

LOCALE	CODICE	DESCRIZIONE COMPONENTE	FINITURA	Q.TA	OPERATORE
CABINA VIP SX	AZ26M-A01_VVE01	RIVESTIMENTO PARETI PRUA	ALLUMINIO	2	Damiano

1 - L 1501 x H.50 x sp 2
2 - L 249 x H.50 x sp 2

2

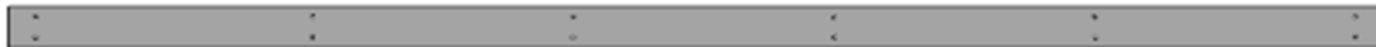

1

MOD AZ 216
ALLUNGATO
RIVESTIMENTI VERSO
PAVIMENTO ED
ELIMINATO LAMINATI

ELEMENTO DA MONTARE
con:
L01_VVE01
e spedire con un unico
imballo

L01_VVE01

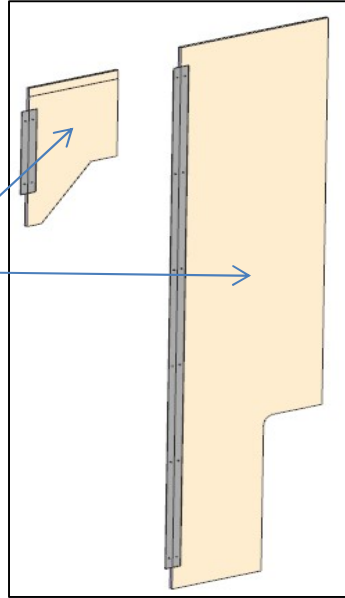

AZ26M

REV. GR 9

LOCALE	CODICE	DESCRIZIONE COMPONENTE	FINITURA	Q.TA	OPERATORE
CABINA VIP SX	AZ26M-A02_VVE01	RIVESTIMENTO PARETI PRUA	ACCIAIO NERO	1	Damiano

1 - L.1726 x H.30 x sp 8

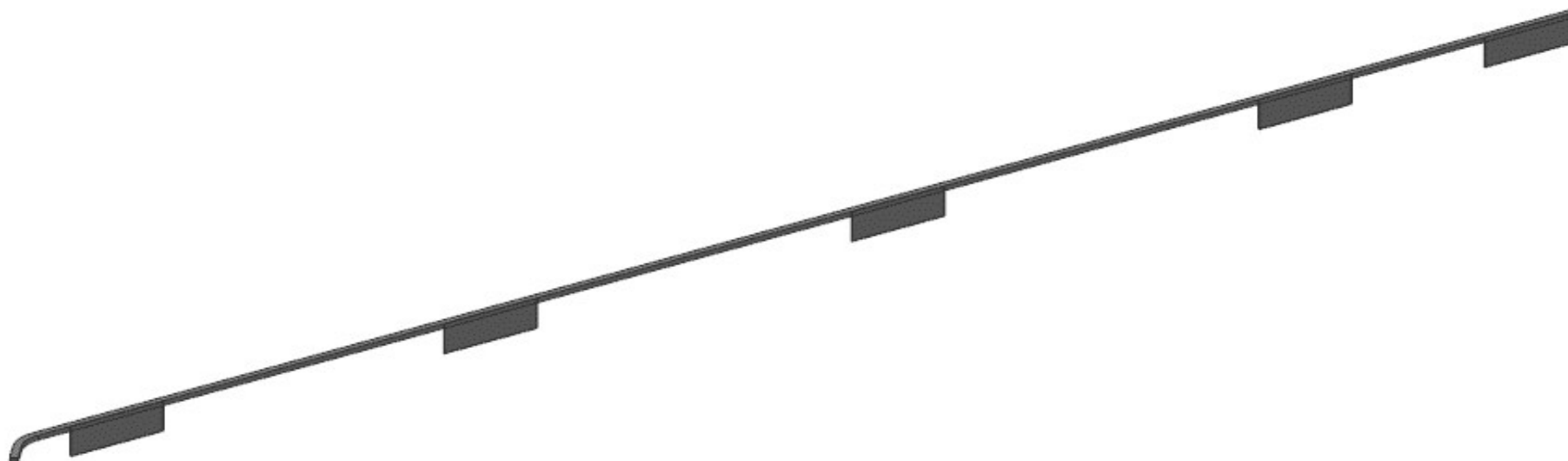

consonni&c

AZ26M

MOD DA GR9

REV. GR 9

LOCALE	CODICE	DESCRIZIONE COMPONENTE	FINITURA	Q.TA	OPERATORE
CABINA VIP SX	AZ26M-R01_VVF01	RIVESTIMENTO PARETI POPPA	LASTRA CHIARA	8	Damiano

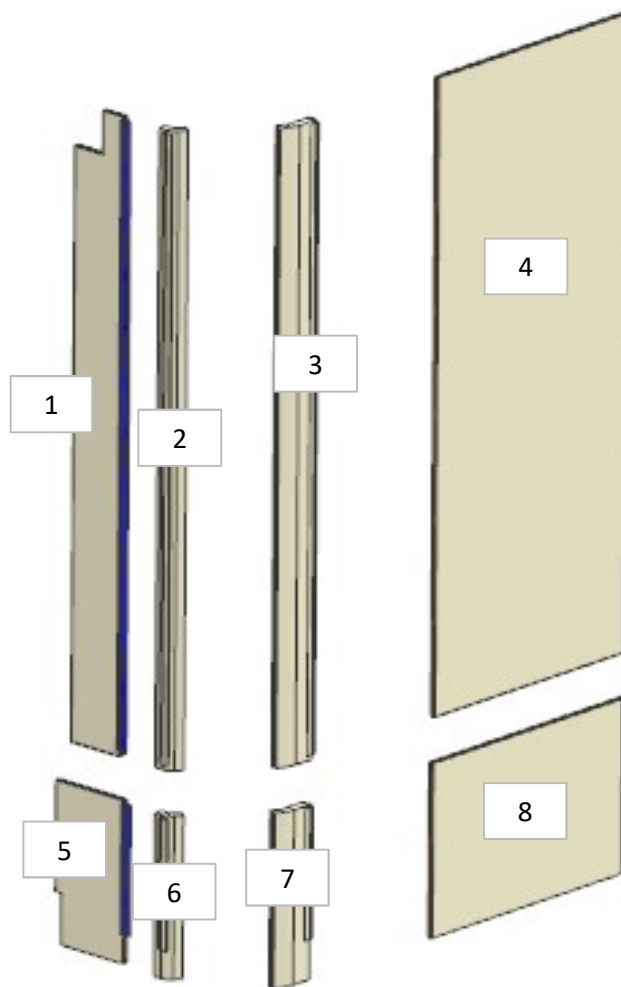

- 1 - L 143 x H.1624 x sp 11
- 2 - L 69 x H.1624 x sp 21
- 3 - L 105 x H.1624 x sp 21
- 4 - L 594 x H.1624 x sp 11
- 5 - L 200 x H. 414 x sp 11
- 6 - L 69 x H. 414 x sp 21
- 7 - L 105 x H. 414 x sp 21
- 8 - L 599 x H. 414 x sp 11

MOD AZ 216
ALLUNGATO
RIVESTIMENTI VERSO
PAVIMENTO ED
ELIMINATO LAMINATI

AZ26M

REV. 01-2023

REV. GR 9

LOCALE	CODICE	DESCRIZIONE COMPONENTE	FINITURA	Q.TA	OPERATORE
CABINA VIP SX	AZ26M-MF_VVF01\ VVF02	RIVESTIMENTO PARETI POPPA			Damiano

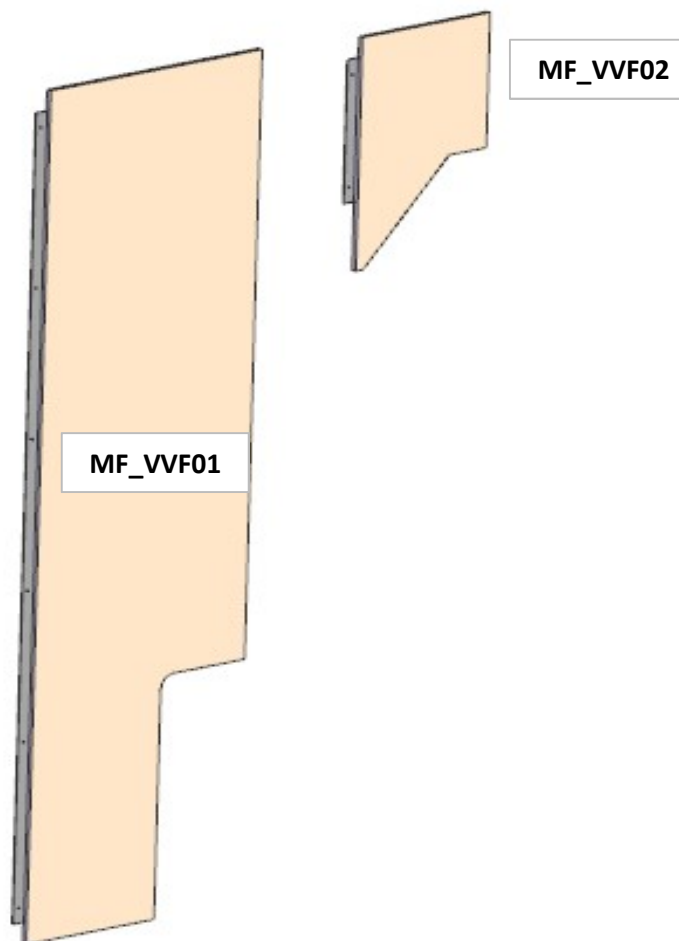

FERRAMENTA:

- N° 2 - FLUSH LOCK
- N° 4 - KEKU ESTRAZIONE FRONTALE COPPIA M/F

AZ26M

MOD DA GR9

REV.9

LOCALE	CODICE	DESCRIZIONE COMPONENTE	FINITURA	Q.TA	OPERATORE
CABINA VIP SX	AZ26M-L01_VVF01	RIVESTIMENTO PARETI POPPA	LACCATO BIANCO RAL 9010	2	Damiano

1 - L 486 x H 1624 x sp 10
2 - L 293 x H 444 x sp 10

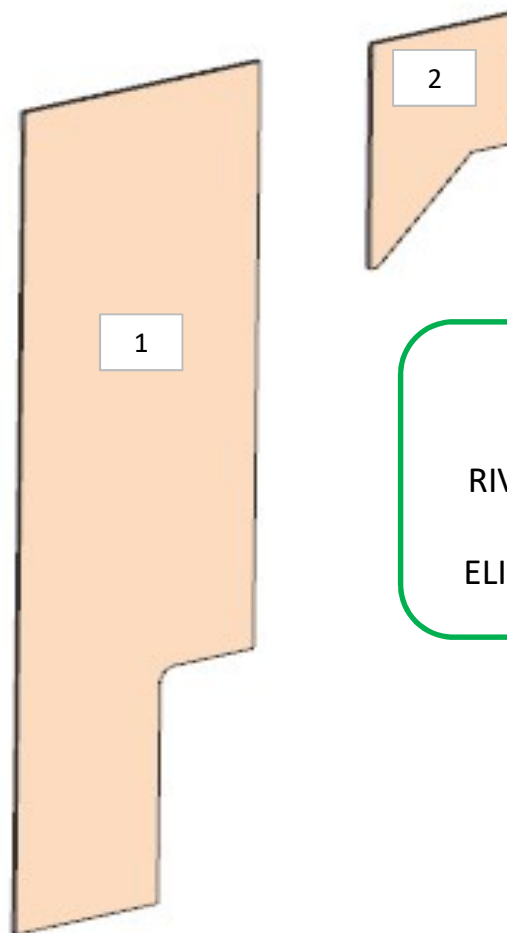

MOD AZ 216
ALLUNGATO
RIVESTIMENTI VERSO
PAVIMENTO ED
ELIMINATO LAMINATI

ELEMENTO DA
MONTARE con:
X01_VVF01
A01_VVF01
e spedire con un unico
imballo

A01_VVF01

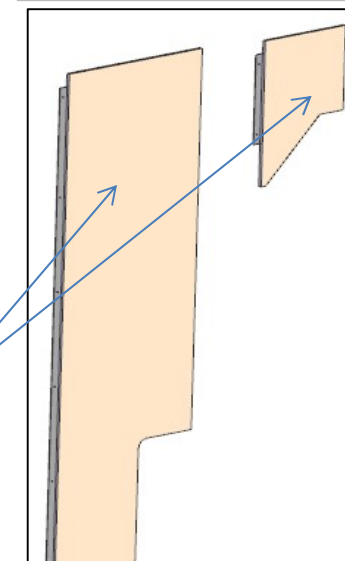

consonni&c

AZ26M

REV. 01-2023

REV. GR 9

LOCALE	CODICE	DESCRIZIONE COMPONENTE	FINITURA	Q.TA	OPERATORE
CABINA VIP SX	AZ26M-A01_VVF01	RIVESTIMENTO PARETI POPPA	ALLUMINIO	2	

1 - L 50 x H 1543 x sp 2
2 - L 50 x H 274 x sp 2

MOD AZ 216
ALLUNGATO
RIVESTIMENTI VERSO
PAVIMENTO ED
ELIMINATO LAMINATI

ELEMENTO DA
MONTARE con:
L01_VVF01
e spedire con un unico
imballo

1

2

L01_VVF01

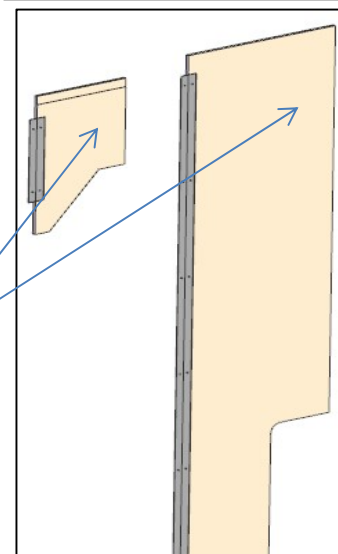

consonni&c

AZ26M

REV. GR 9

LOCALE	CODICE	DESCRIZIONE COMPONENTE	FINITURA	Q.TA	OPERATORE
CABINA VIP SX	AZ26M-A02_VVF01	RIVESTIMENTO PARETI POPPA	ACCIAIO NERO	2	Damiano

- 1 - SVILUPPO L. 995 x H.30 x sp 8
- 2 - SVILUPPO L. 209 x H.30 x sp 8

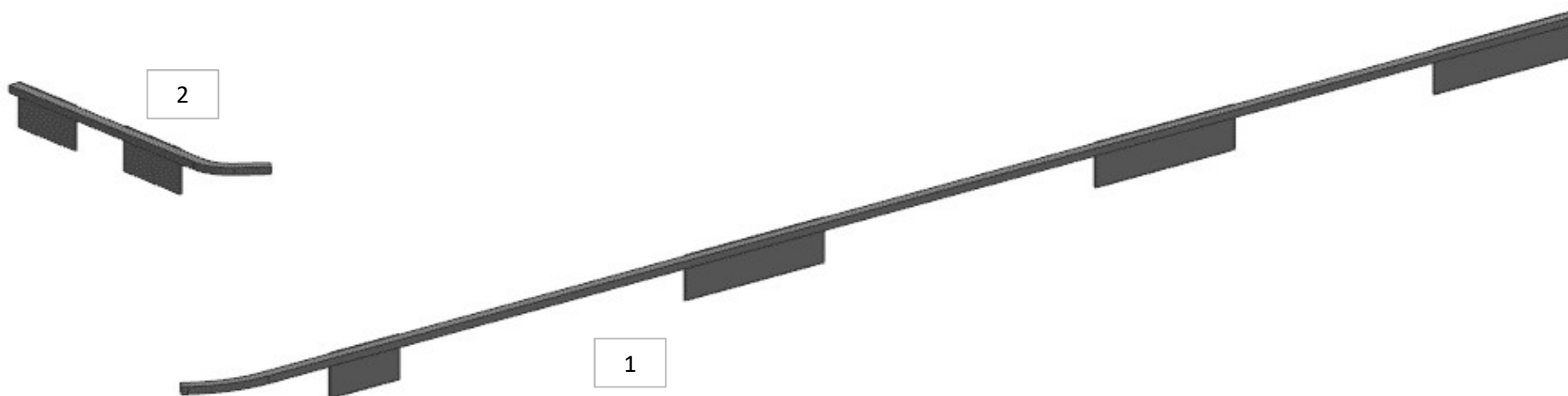

AZ26M

DA GR10

REV. GR .10

LOCALE	CODICE	DESCRIZIONE COMPONENTE	FINITURA	Q.TA	OPERATORE
CABINA VIP SX	AZ26M-MG_VVG01/02	RIVESTIMENTO PARETI CENTRO NAVE		1	Damiano

RETRO

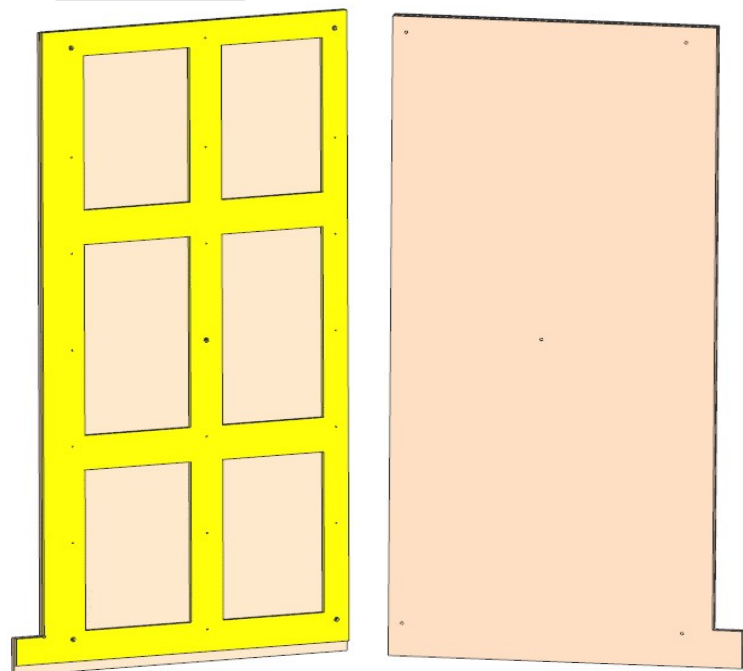

MG_VVG01

RETRO

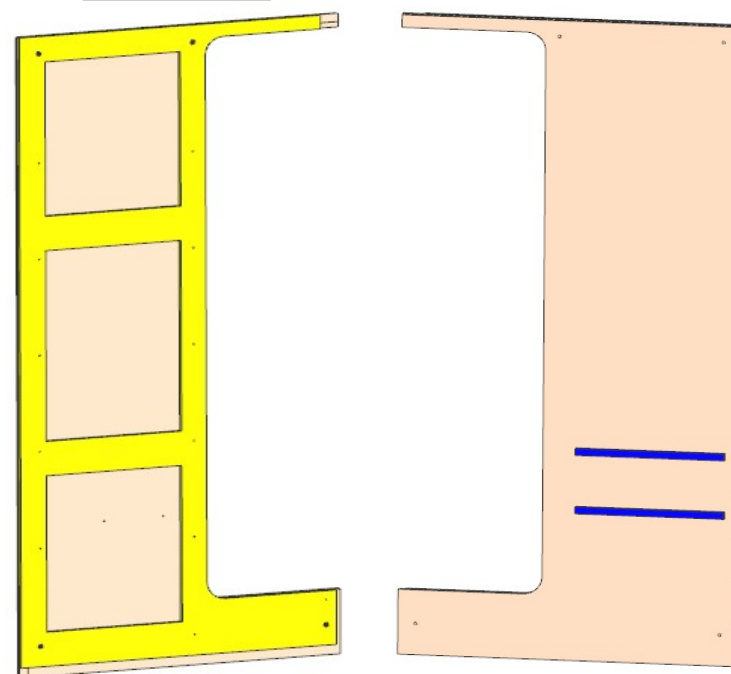

MG_VVG02

AZ26M

MOD DA GR10

REV.10

LOCALE	CODICE	DESCRIZIONE COMPONENTE	FINITURA	Q.TA	OPERATORE
CABINA VIP SX	AZ26M-L01_VVG01	RIVESTIMENTO PARETI CENTRO NAVE	LACCATO BIANCO RAL 9010	9	Damiano

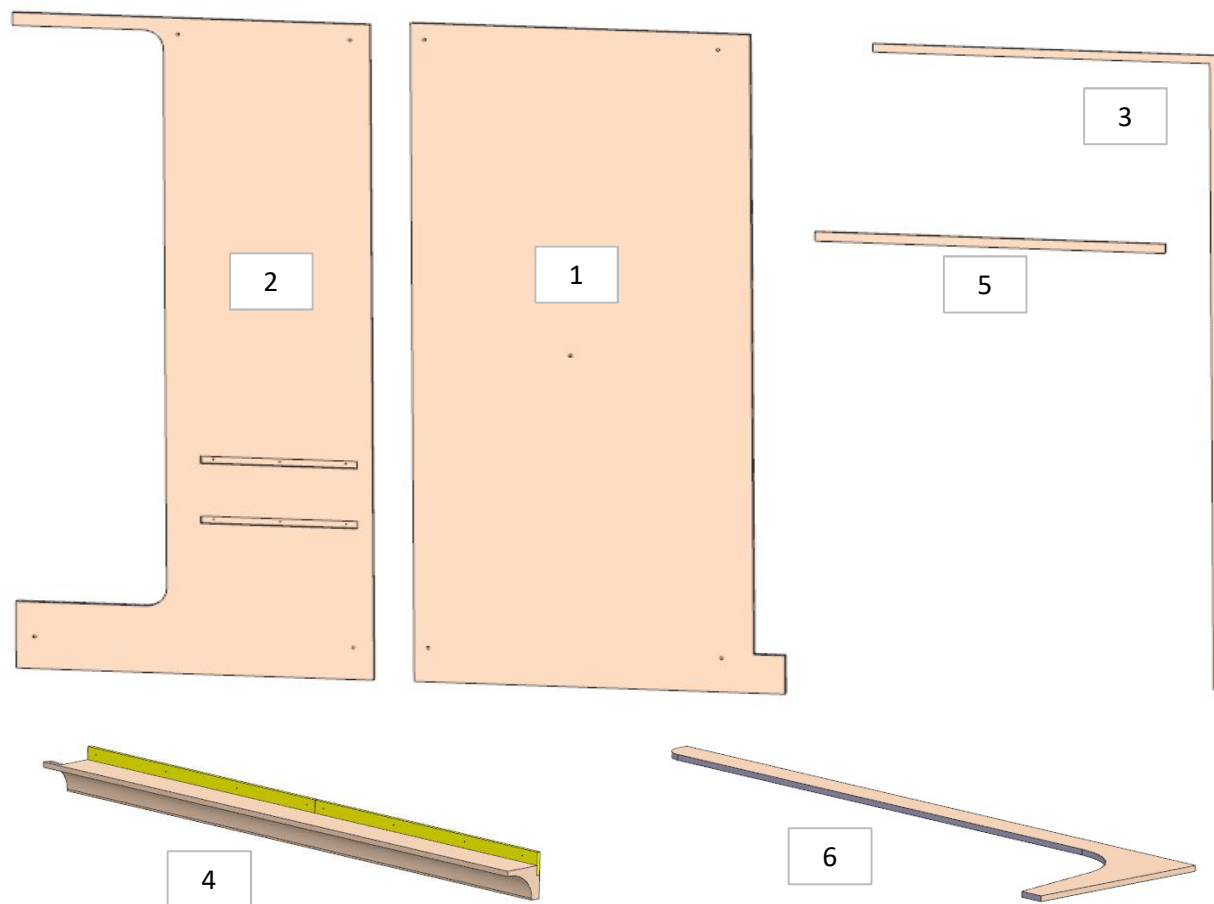

ELEMENTO DA MONTARE con:
MG_VVG01
MG_VVG02
e spedire con un unico imballo

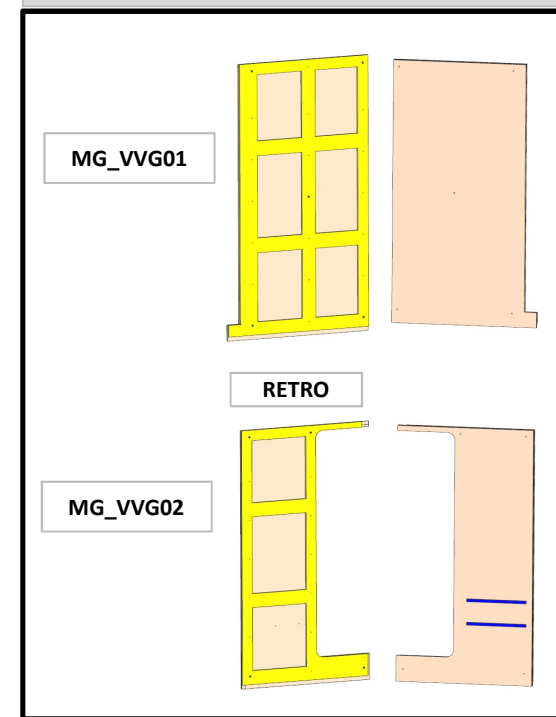

consonni&c

AZ26M

MOD DA GR9

REV. GR 9

LOCALE	CODICE	DESCRIZIONE COMPONENTE	FINITURA	Q.TA	OPERATORE
CABINA VIP SX	AZ26M-R01_VVG01	RIVESTIMENTO PARETI CENTRO NAVE	LASTRA CHIARA	4	Damiano

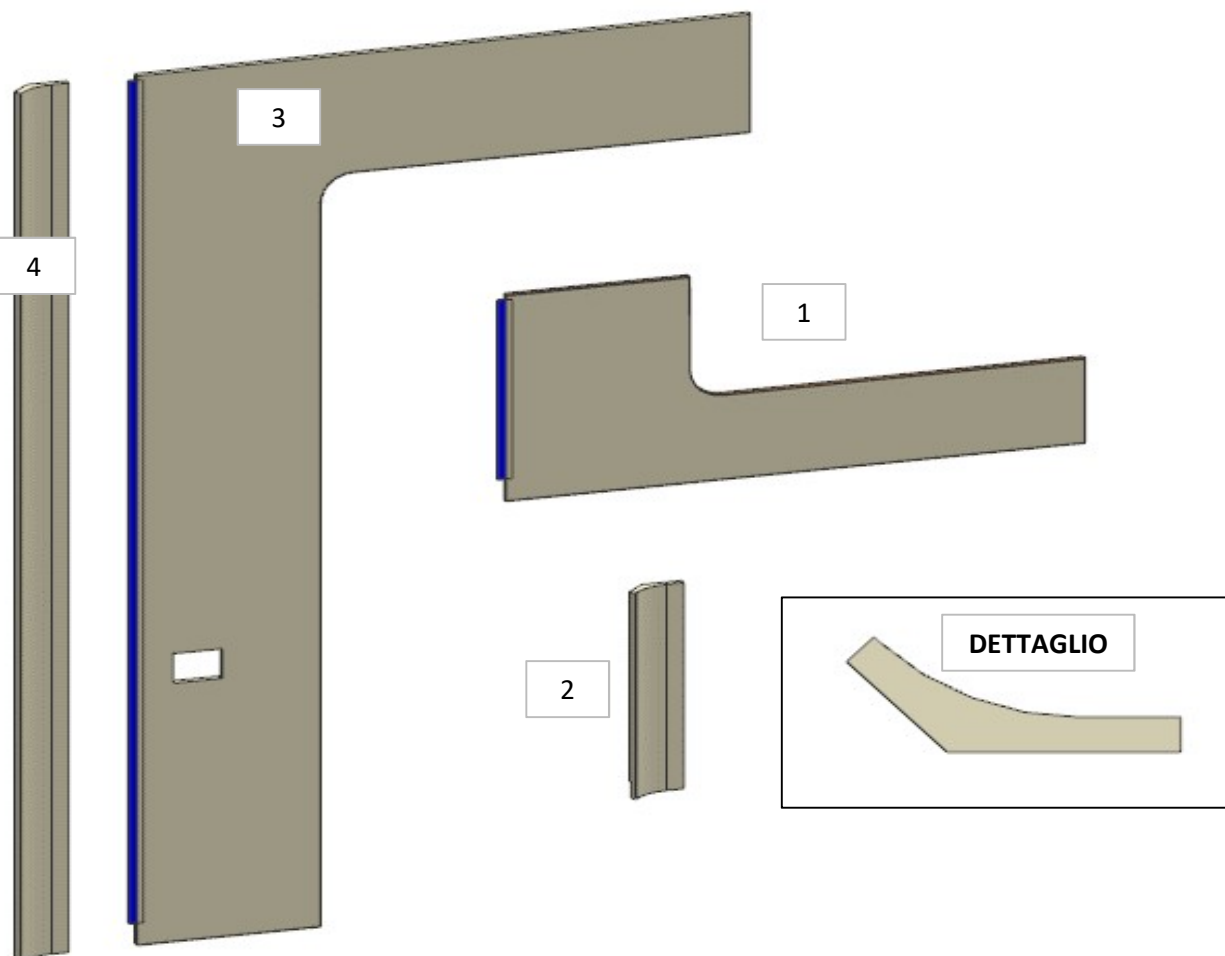

- 1 - L.942 x H.415 x sp 11
- 2 - L.106 x H.415 x sp 11
- 3 - L.996 x H.1624 x sp 11
- 4 - L.106 x H. 1624 x sp 11

MOD AZ 216
ALLUNGATO
RIVESTIMENTI VERSO
PAVIMENTO ED
ELIMINATO LAMINATI

AZ26M

REV. GR 9

LOCALE	CODICE	DESCRIZIONE COMPONENTE	FINITURA	Q.TA	OPERATORE
CABINA VIP SX	AZ26M-A01_VVG01	RIVESTIMENTO PARETI CENTRO NAVE	ACCIAIO NERO	1	Damiano

1 - L..365 x H..30 x sp 8

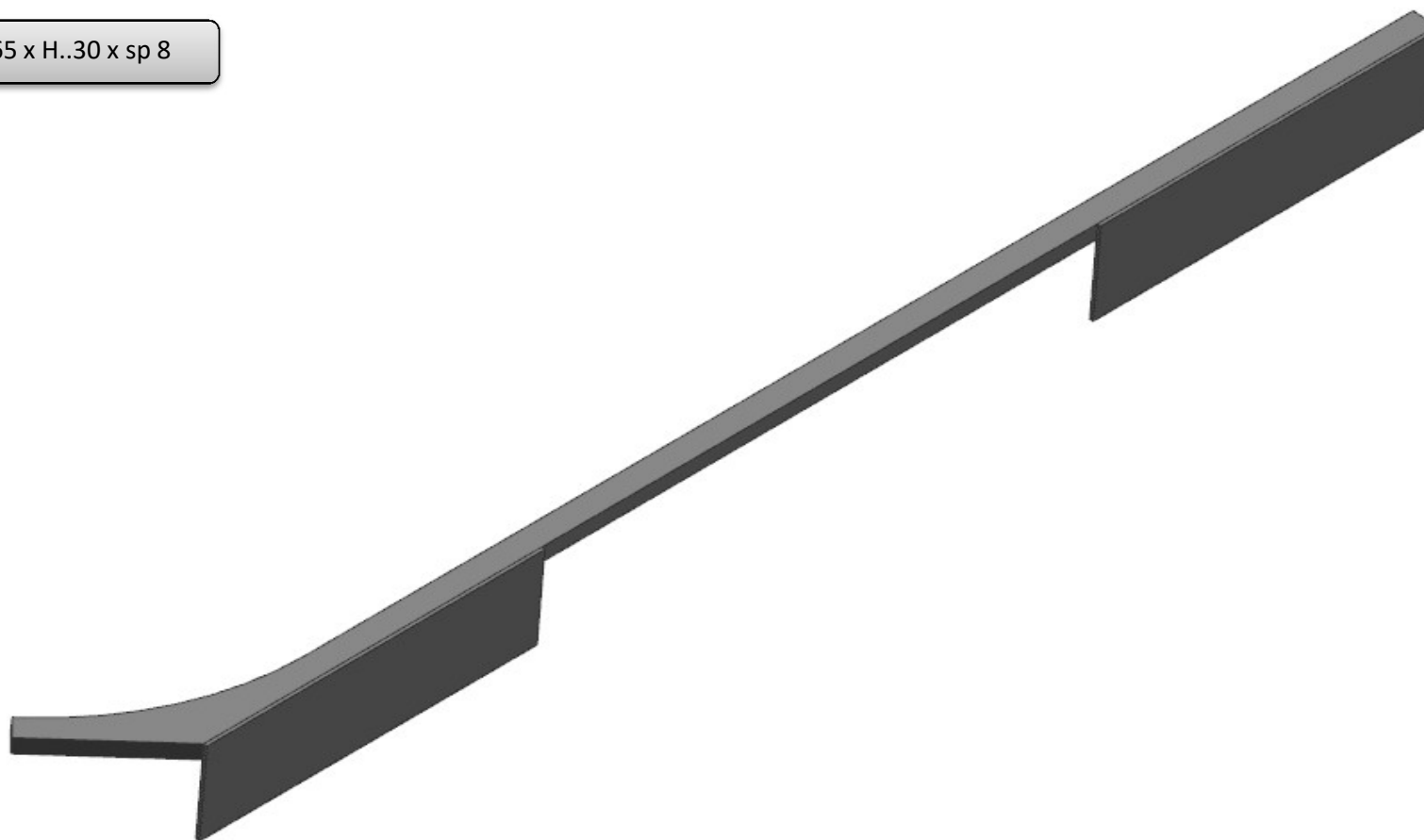

consonni&c

AZ26M

MOD DA GR5

REV. GR 9

LOCALE	CODICE	DESCRIZIONE COMPONENTE	FINITURA	Q.TA	OPERATORE
CABINA VIP SX	AZ26M-MG_VVN01	PLENUM ARMADIO	LACCATO BRONZO	4	Damiano

ELEMENTO DA MONTARE:
MG_VVN01
e spedire con un unico imballo

1

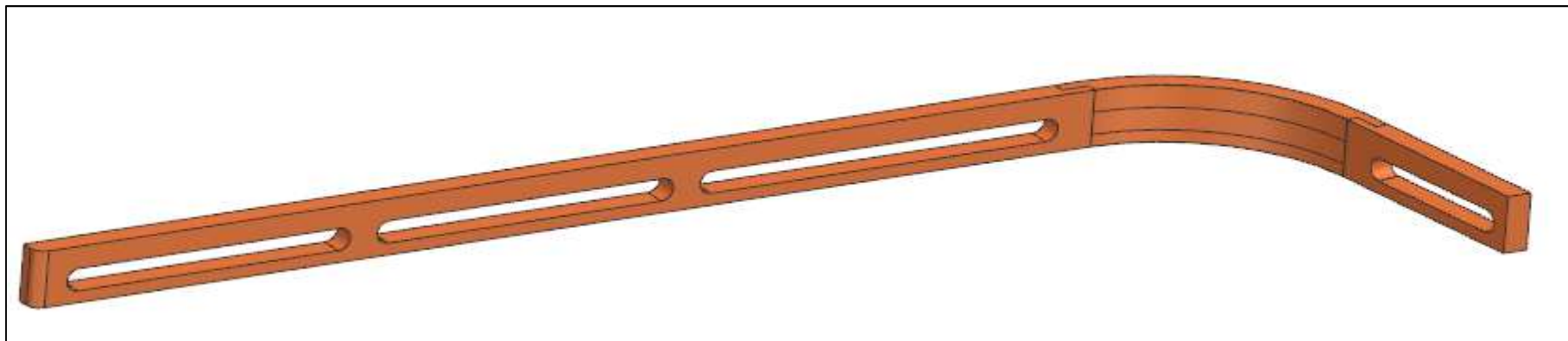

AZ26M

REV. GR 9

LOCALE	CODICE	DESCRIZIONE COMPONENTE	FINITURA	Q.TA	OPERATORE
BAGNO VIP SX	AZ26M-L01_JJA01_01	STRUTTURA MURATA DOCCIA	LACCATO BIANCO RAL 9010	6	Damiano

- 1 - L 1199 x H.1570 x sp 16
- 2 - L 765 x H.484 x sp 16
- 3 - L 961 x H.243 x sp 10
- 4 - L 795 x H.239 x sp 10
- 5 - L 795 x H 243 x sp 10
- 6 - L 960 x H 192 x sp 10

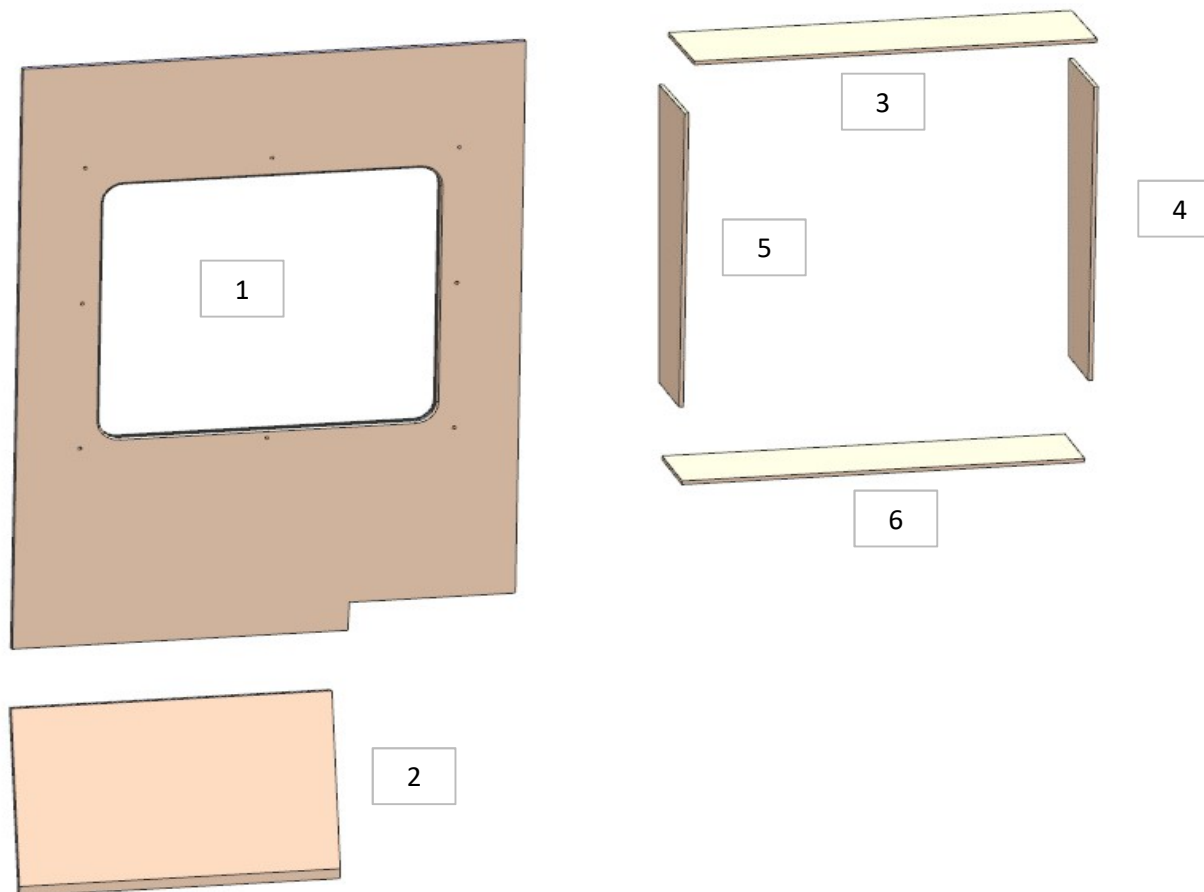

AZ26M

REV. GR 9

LOCALE	CODICE	DESCRIZIONE COMPONENTE	FINITURA	Q.TA	OPERATORE
BAGNO VIP SX	AZ26M-L01_JJB01	RIVESTIMENTI PARETI DOCCIA	LACCATO BIANCO RAL 9010	6	Damiano

- 1 - L 628 x H 2043 x sp 10
- 2 - sviluppo L 309 x H 2043 x sp 10
- 3 - L 817 x H 104 x sp 10
- 4 - L 839 x H 41 x sp 10
- 5 - sviluppo L 260 x H 1494 x sp 10
- 6 - L 631 x H 1494 x sp 10

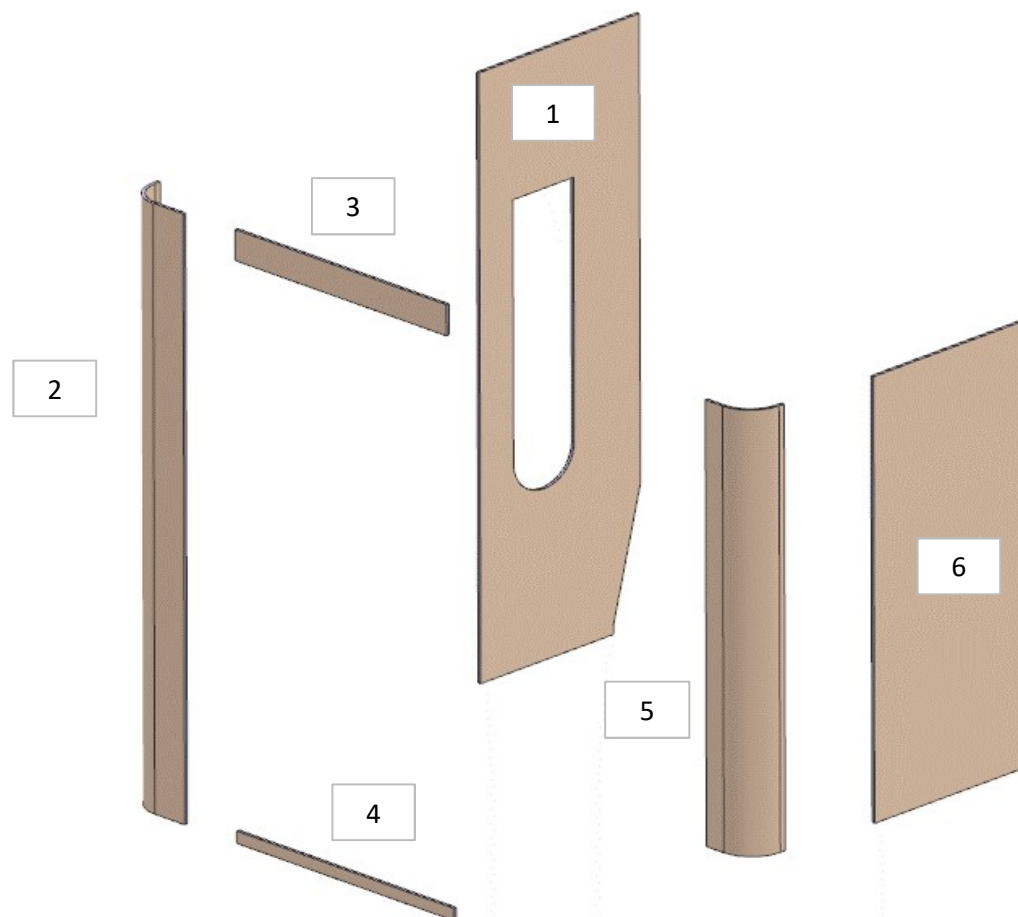

FERRAMENTA:

- N° 2 - FLUSH LOCK
- N° 4 - KEKU ESTRAZIONE FRONTALE COPPIA M/F

AZ26M

REV. GR 9

LOCALE	CODICE	DESCRIZIONE COMPONENTE	FINITURA	Q.TA	OPERATORE
BAGNO VIP SX	AZ26M-R01_JJH01	RIV. PARETI INGRESSO BAGNO	LASTRA CHIARA	4	Damiano

- 1 - L.106 x H.2029 x sp 11
- 2 - L.71 x H.2029 x 71
- 3 - L 518 x H.2029 x sp 11
- 4 - L.429 x H.2029 x sp 11

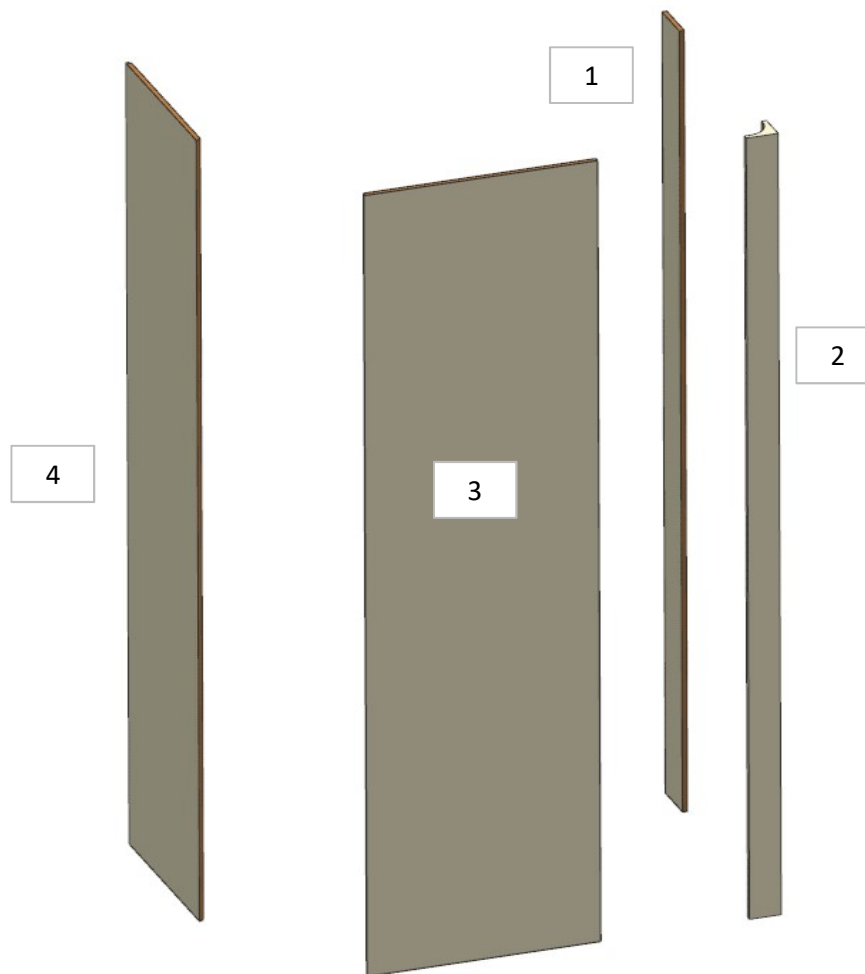

AZ26M

REV. GR 9

LOCALE	CODICE	DESCRIZIONE COMPONENTE	FINITURA	Q.TA	OPERATORE
BAGNO VIP SX	AZ26M-L01_JJH01	RIV. PARETI INGRESSO BAGNO	LACCATO BIANCO RAL 9010	7	Damiano

- 1 - L.817 x H.94 x sp 10
- 2 - L.817 x H 25 x sp 10
- 3 - L.268 x H.2029 x sp 10
- 4- L. 69 x H 1183 x 69
- 5 - L.1012 x H.1183 x sp 10
- 6 - L.69 x H. 1183 x 60
- 7 - L 451 x H.2029 x sp 10

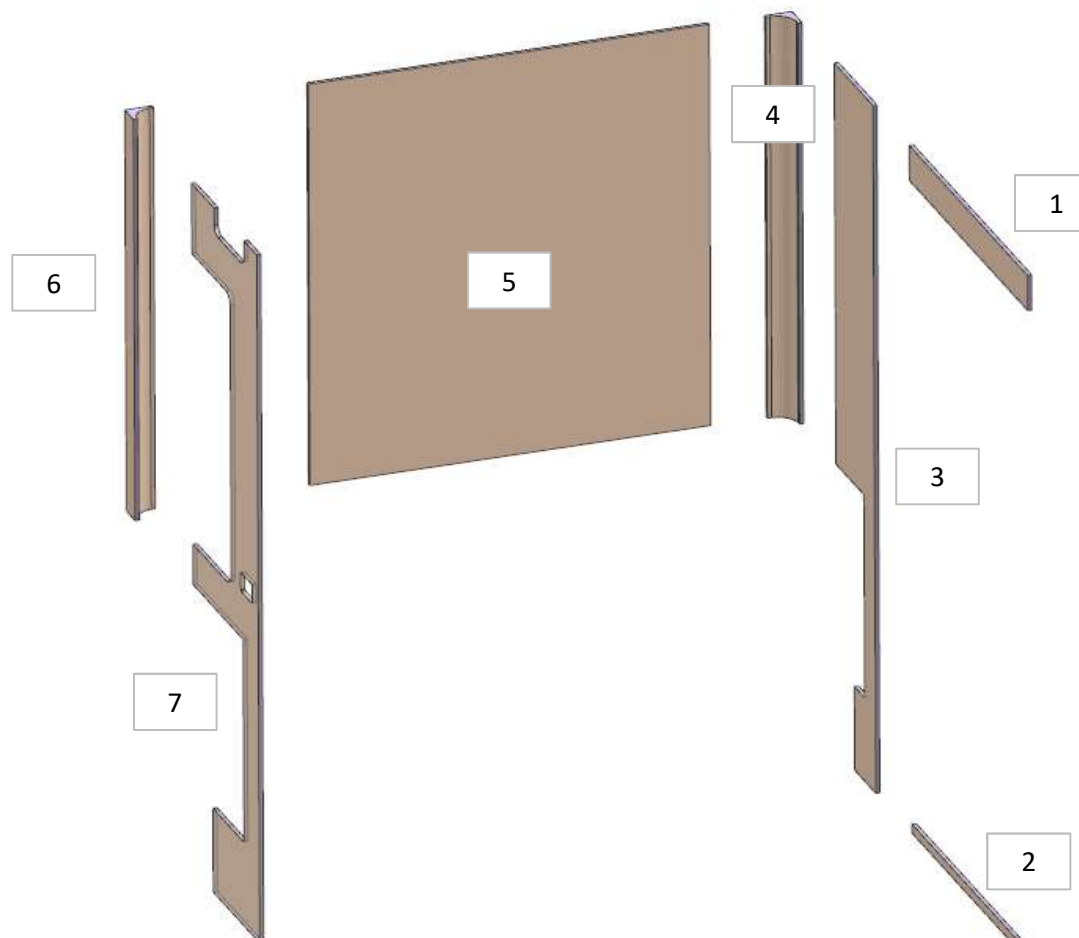

AZ26M

MOD DA GR4/5

REV. GR 9

LOCALE	CODICE	DESCRIZIONE COMPONENTE	FINITURA	Q.TA	OPERATORE
BAGNO VIP SX	AZ26M-MF_JJI01	MOBILE LAVELLO			Damiano

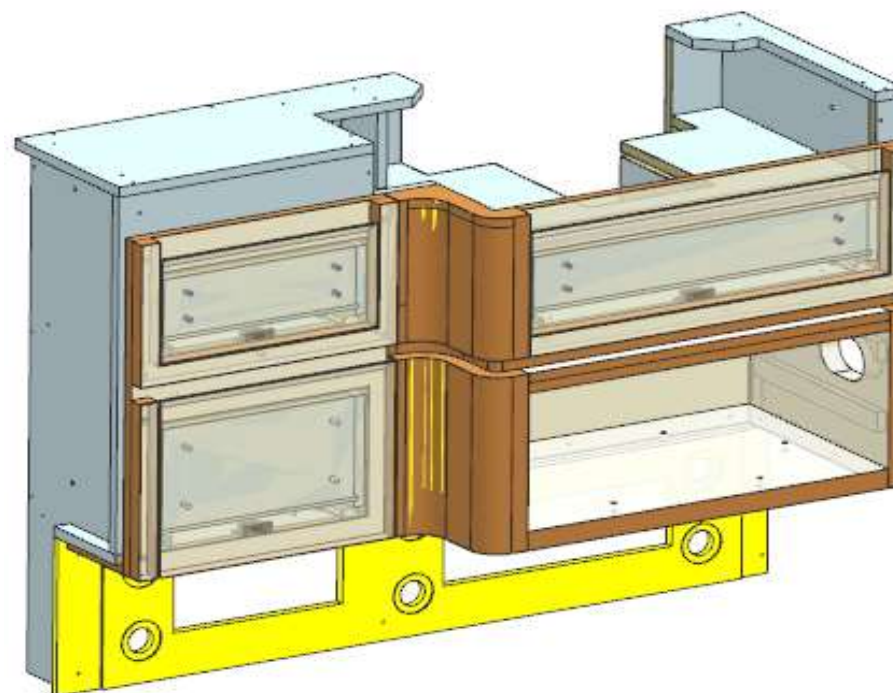

FERRAMENTA:

- N° 1 - GUIDA 350
- N° 2 - GUIDA 250
- N° 3 - CALAMITA PER CASSETTI
- N° 6 - FITLOCK MASCHIO
- N° 6 - FITLOCK FEMMINA
- N° 29 - VITI 6MA
- N° 25 - BUSSOLA ZAMA 6MA
- N° 62 - SPINA diam 8

AZ26M

MOD DA GR5

REV. GR 9

LOCALE	CODICE	DESCRIZIONE COMPONENTE	FINITURA	Q.TA	OPERATORE
BAGNO VIP SX	AZ26M-JJI01	MOBILE LAVELLO	NADIR \ GREZZO SPRUZZATO ANTIMUFFA	1	Damiano

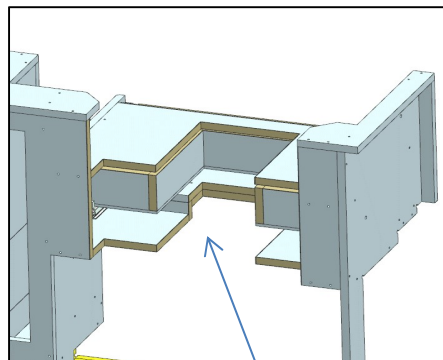

DETTAGLIO MODIFICA
SUL RETRO MOBILE

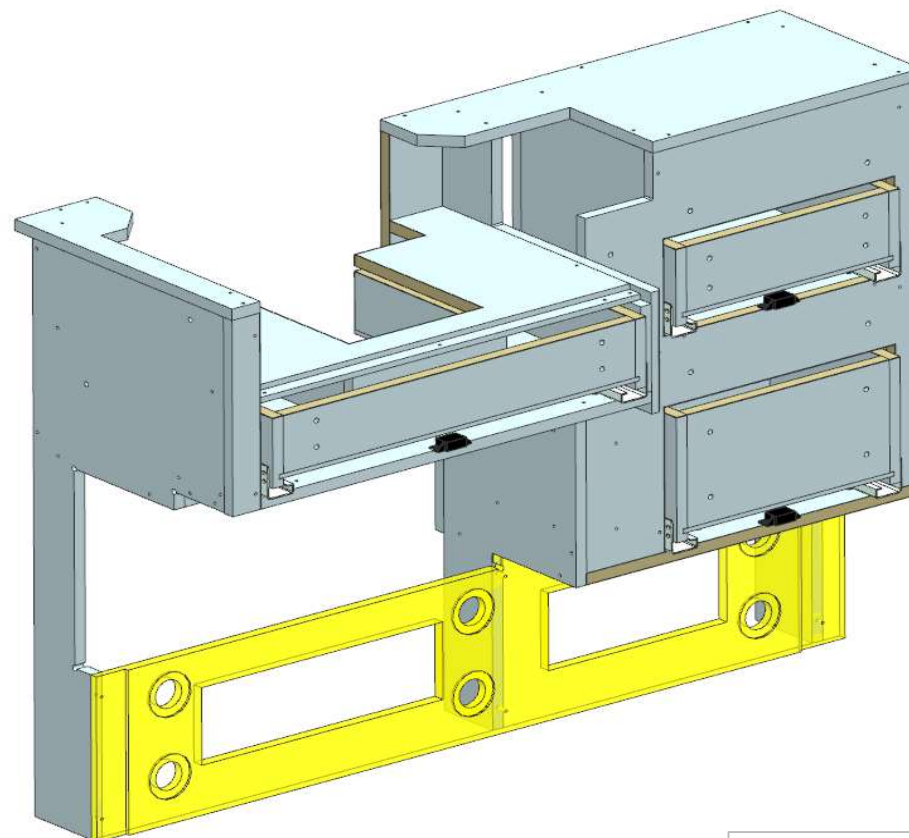

R01_JJI01

MOD.147 DA GR.5 -
REALIZZATO SCASSO
PER SIFONE

ELEMENTO DA MONTARE con:
R01_JJI01
L01_JJI01
e spedire con un unico imballo

FERRAMENTA:

- N° 1 - GUIDA 350
- N° 2 - GUIDA 250
- N° 3 - CALAMITA PER CASSETTI
- N° 6 - FITLOCK MASCHIO
- N° 6 - FITLOCK FEMMINA
- N° 29 - VITI 6MA
- N° 25 - BUSSOLA ZAMA 6MA
- N° 62 - SPINA diam 8

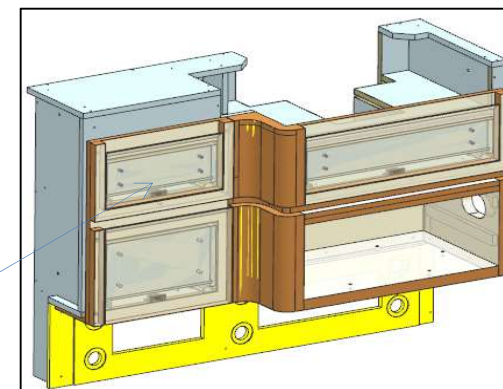

AZ26M

MOD DA GR4/5

REV. GR 9

LOCALE	CODICE	DESCRIZIONE COMPONENTE	FINITURA	Q.TA	OPERATORE
BAGNO VIP SX	AZ26M-R01_JJI01	MOBILE LAVELLO	LASTRA CHIARA	15	Damiano

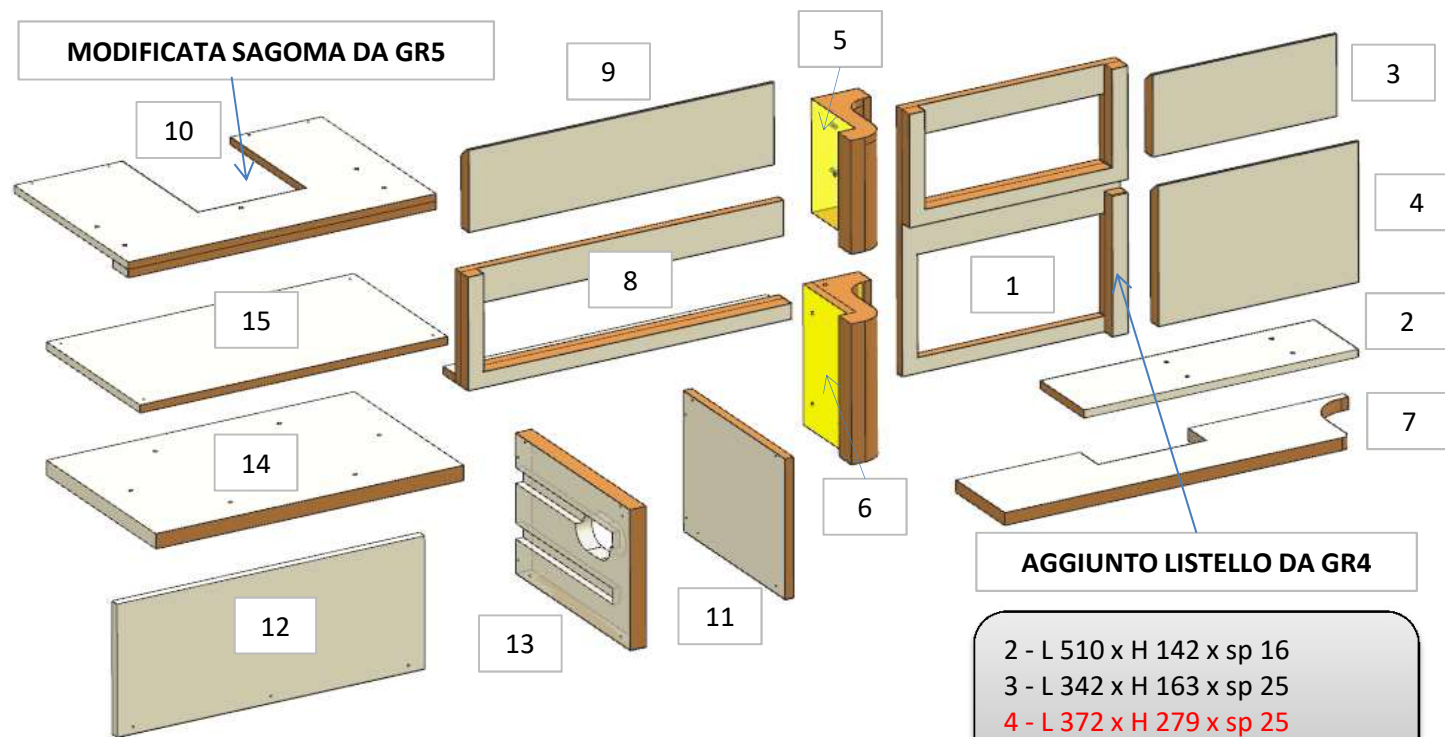

- 9 - L 657 x H 163 x sp 25
- 10 - L 571 x H 371 x sp 31
- 11 - L 329 x H 277 x sp 16
- 12 - L 571 x H 264 x sp 16
- 13 - L 371 x H 279 x sp 30
- 14 - L 571 x H 355 x sp 30
- 15 - L 572 x H 303 x sp 16

ELEMENTO DA MONTARE con:
JJI01
L01_JJI01
 e spedire con un unico imballo

- 2 - L 510 x H 142 x sp 16
- 3 - L 342 x H 163 x sp 25
- 4 - L 372 x H 279 x sp 25
- 7 - L 721 x H 159 x sp 25

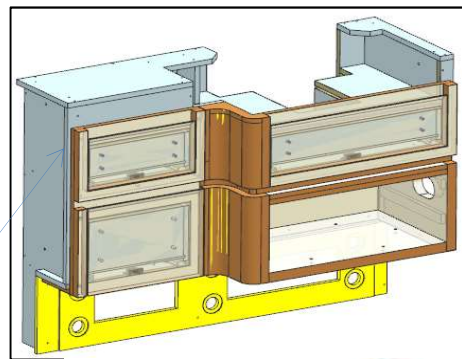

- MOD.116 DA GR.4 - AGGIUNTO LISTELLO AL PEZZO N.1 E MODIFICATE DIMENSIONI PEZZO N.4
 - MOD.147 DA GR.5 - MODIFICATA SAGOMA PEZZO N.10 E AGGIUNTO PEZZO N.15

AZ26M

REV. GR 9

LOCALE	CODICE	DESCRIZIONE COMPONENTE	FINITURA	Q.TA	OPERATORE
BAGNO VIP SX	AZ26M-L01_JJI01_01	MOBILE LAVELLO	LACCATO BIANCO RAL 9010	3	Damiano

1 - 3 - L. 69 x H.231 x sp 77
2 - L. 1011 x H.231 x sp 10

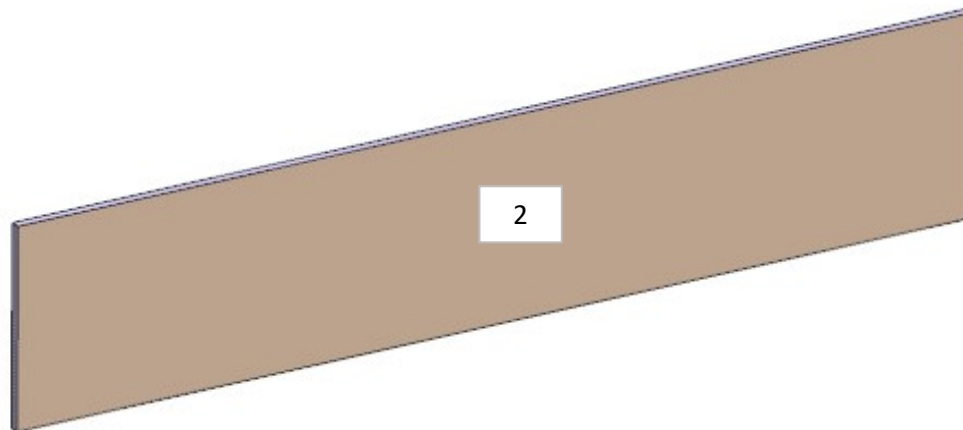

AZ26M

REV. 01-2023

REV. GR 9

LOCALE	CODICE	DESCRIZIONE COMPONENTE	FINITURA	Q.TA	OPERATORE
BAGNO VIP SX	AZ26M-MG_JJN01	NICCHIA LATERALE LAVABO			Damiano

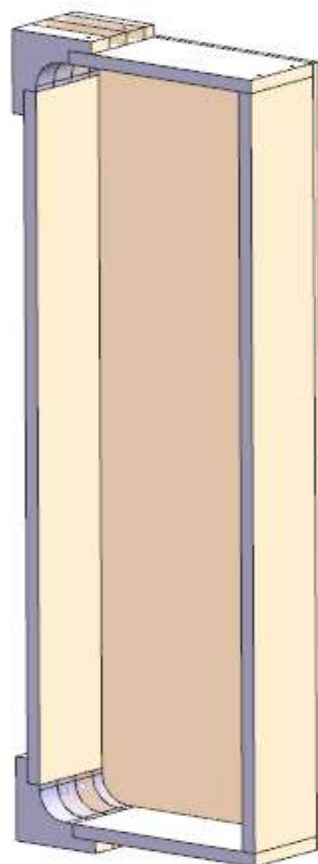

AZ26M

REV. 01-2023

REV. GR 9

LOCALE	CODICE	DESCRIZIONE COMPONENTE	FINITURA	Q.TA	OPERATORE
BAGNO VIP SX	AZ26M-L01_JJN01	NICCHIA LATERALE LAVABO	LACCATO BIANCO RAL 9010	2	Damiano

1 - L.333 x H 974 x sp 16
2 - L.302 x H 944 x 106

**MODIFICATO METODO
DI MONTAGGIO**

FERRAMENTA:
N° 12 - SPINA diam 8
N° 4 - BUSSOLA ZAMA 6MA
N° 4 - VITI 6MA

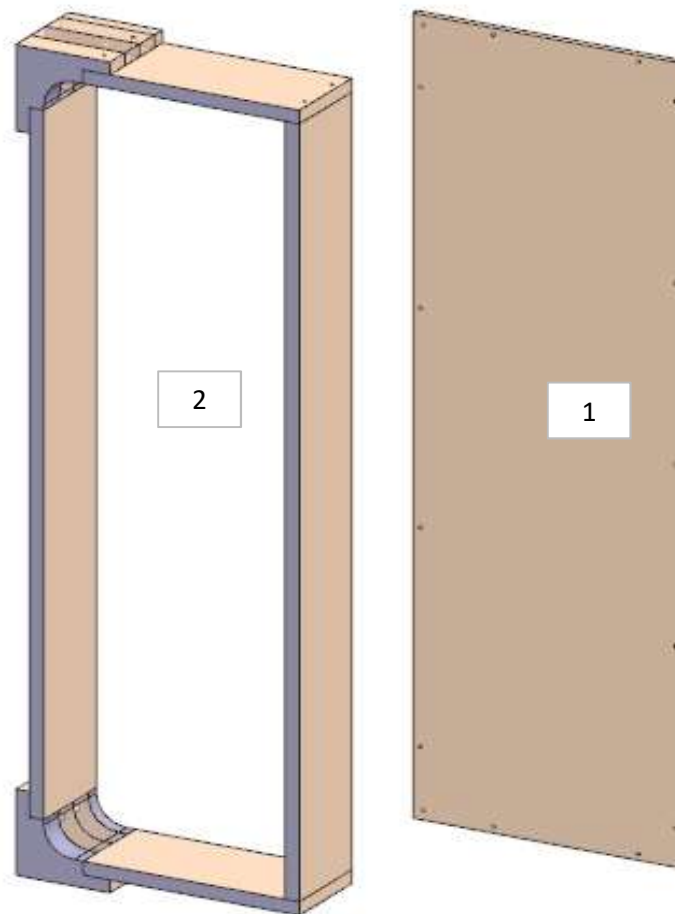

**ELEMENTO DA
MONTARE
MG01_JJN01
e spedire con un
unico imballo**

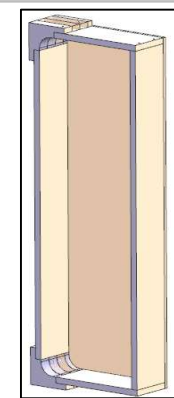

AZ26M

MOD DA GR2

REV. GR 9

LOCALE	CODICE	DESCRIZIONE COMPONENTE	FINITURA	Q.TA	OPERATORE
BAGNO VIP SX	AZ26M-X01_JJQ01	CONTENITORE PORTA SAPONE	LAMINATO NERO	1	Damiano

1 - L.190 x H 100 x 90

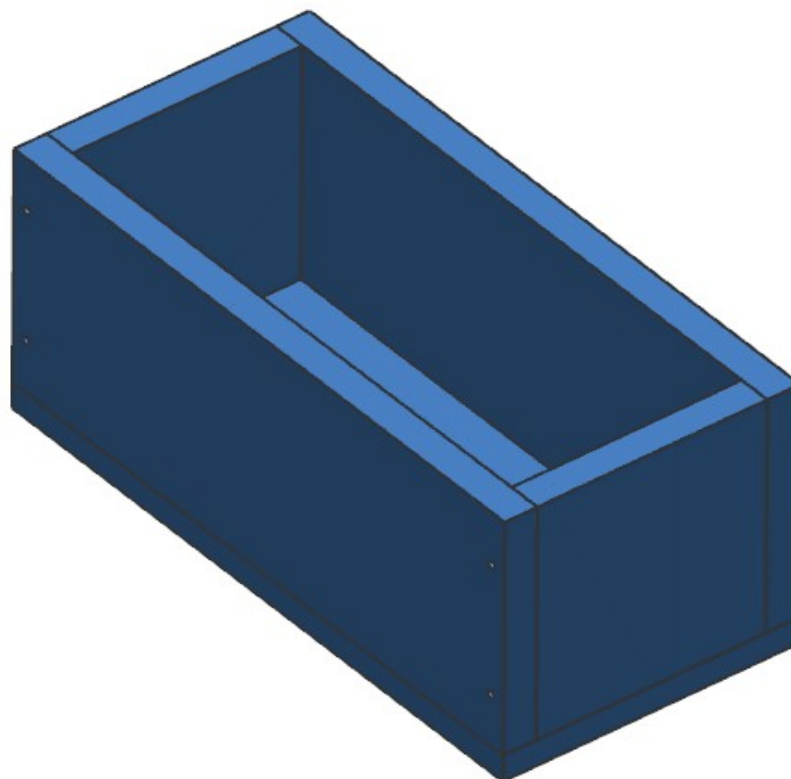

- MOD.138 DA GR.2 - AGGIUNTA
SCATOLA PORTA SAPONE IN
LAMINATO NERO

AZ26M

REV. 01-2023

REV. GR 9

LOCALE	CODICE	DESCRIZIONE COMPONENTE	FINITURA	Q.TA	OPERATORE
CABINA OSPITI DX	AZ26M-MF_RA01\RA02	STRUTTURA MURATA TESTATA LETTO			Damiano

MF_RA02

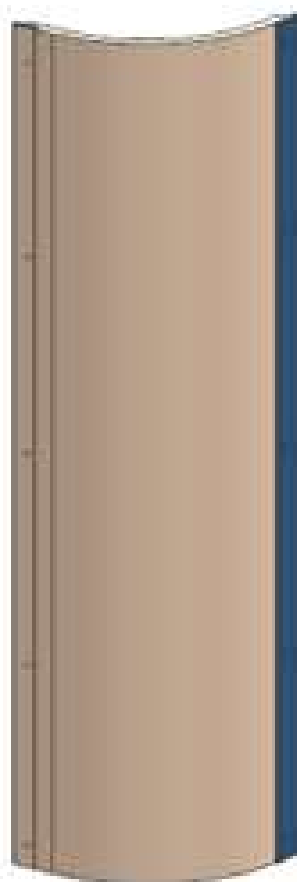

MF_RA01



MOD 216
ELIMINATI LAMINATI NERI ALLA
BASE DEI RIVESTIMENTI

FERRAMENTA:

N° 2 - FLUSH LOCK
N° 4 - KEKU ESTRAZIONE
FRONTALE COPPIA M/F

AZ26M

MOD DA GR5

REV. GR 9

LOCALE	CODICE	DESCRIZIONE COMPONENTE	FINITURA	Q.TA	OPERATORE
CABINA OSPITI DX	AZ26M-L01_RA01	STRUTTURA MURATA TESTATA LETTO	LACCATO BIANCO RAL 9010	11	Damiano

- MOD.139 DA GR.5 - RIMOSI PEZZI N.12-13

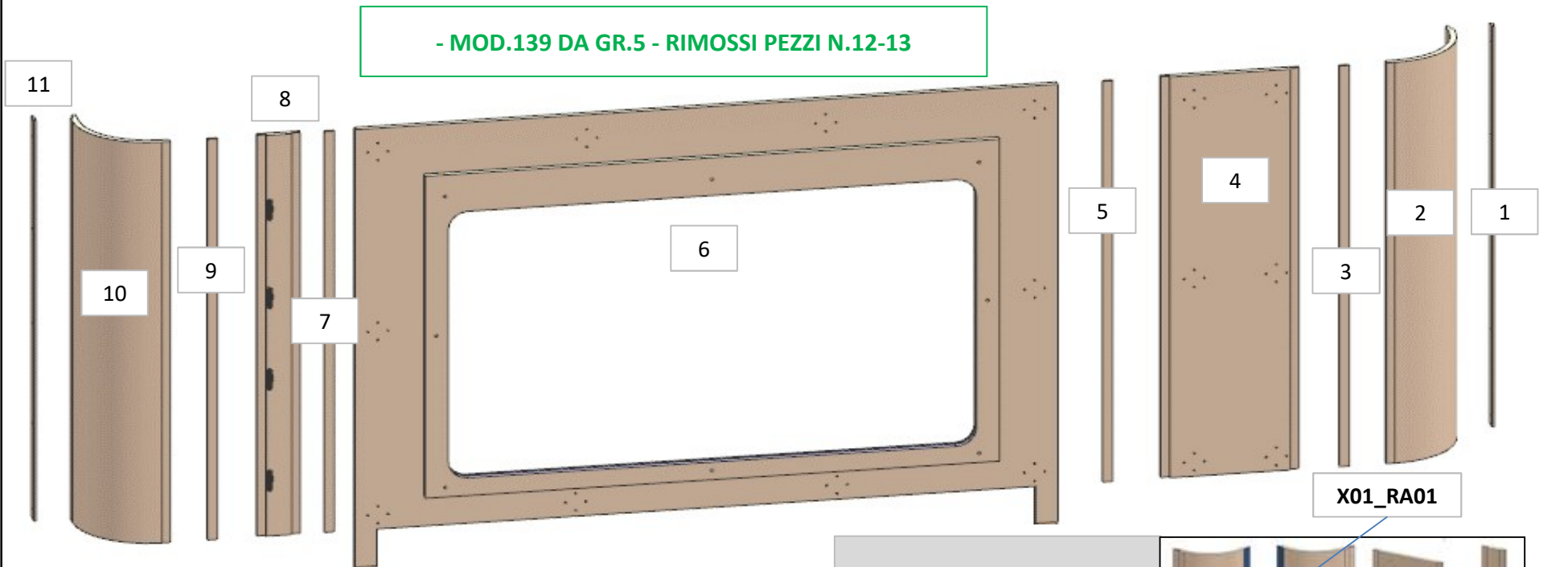

DET. PZ 1 e 11

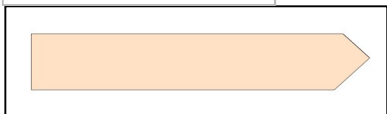

- 1 - 11 - L..30 x H.1160 x sp 6
- 2 - 10 - L..332 x H.1160 x sp 16
- 3 - 5 - 7 - 9 L..25 x H.1160 x sp 16
- 4 - L..340 x H.1160 x sp 16
- 6 - L..1724 x H.1287 x sp 16
- 8 - L..106 x H.1160 x sp 16

ELEMENTO DA MONTARE
con:
X01_RA01
e spedire con un unico
imballo

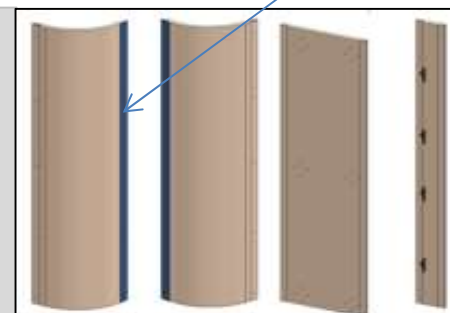

consonni&c

AZ26M

REV. 01-2023

REV. GR 9

LOCALE	CODICE	DESCRIZIONE COMPONENTE	FINITURA	Q.TA	OPERATORE
CABINA OSPITI DX	AZ26M-X01_RA01	STRUTTURA MURATA TESTATA LETTO	LAMINATO NERO	2	Damiano

1 - 2 - L 1159 x H 40 x sp 3

1

2

MOD 216
ELIMINATI LAMINATI NERI ALLA
BASE DEI RIVESTIMENTI

AZ26M

REV. GR 9

LOCALE	CODICE	DESCRIZIONE COMPONENTE	FINITURA	Q.TA	OPERATORE
CABINA OSPITI DX	AZ26M-MG_RA01\RA02	STRUTTURA MURATA TESTATA LETTO			Damiano

MG_RA01

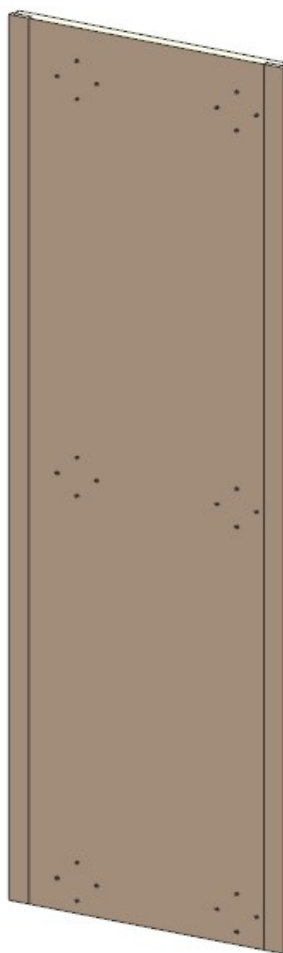

MG_RA02

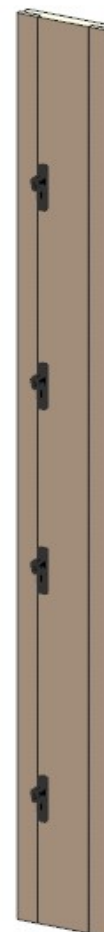

FERRAMENTA:

N° 2 - FLUSH LOCK
N° 4 - KEKU ESTRAZIONE
FRONTALE COPPIA M/F

AZ26M

MOD DA GR5

REV. GR 9

LOCALE	CODICE	DESCRIZIONE COMPONENTE	FINITURA	Q.TA	OPERATORE
CABINA OSPITI DX	AZ26M-L02_RA01	STRUTTURA MURATA TESTATA LETTO	LACCATO NCS S3020-Y30R	4	Damiano

1 - 2 - L 936 x H 212 x sp 11
2 - 4 - L 1394 x H 212 x sp 11

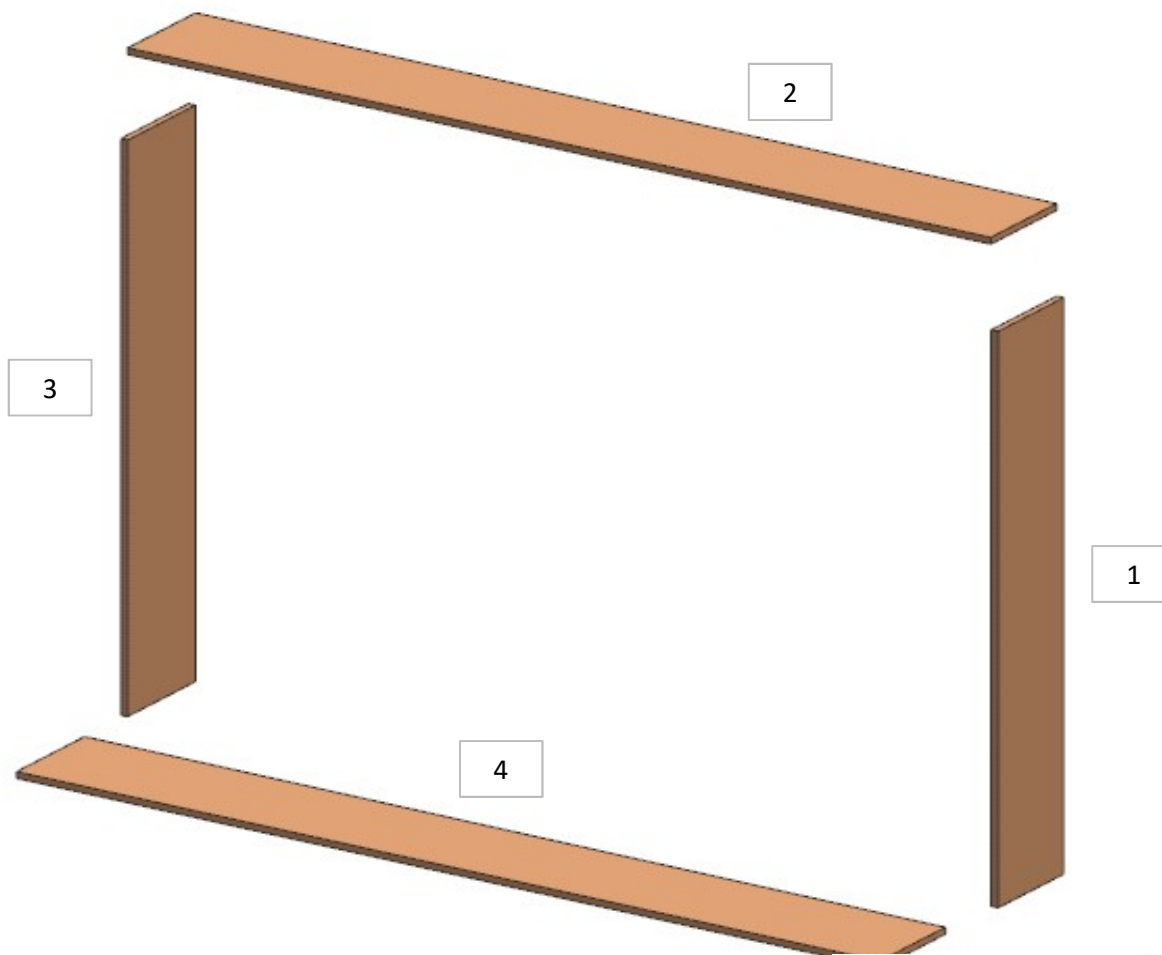

- MOD.146 DA GR.5 - MODIFICATE
DIMENSIONI TUTTI I PEZZI

AZ26M

MOD DA GR9

REV. GR9

LOCALE	CODICE	DESCRIZIONE COMPONENTE	FINITURA	Q.TA	OPERATORE
CABINA OSPITI DX	AZ26M-R01_RE01	RIVESTIMENTO PARETI PRUA	LASTRA CHIARA	4	Damiano

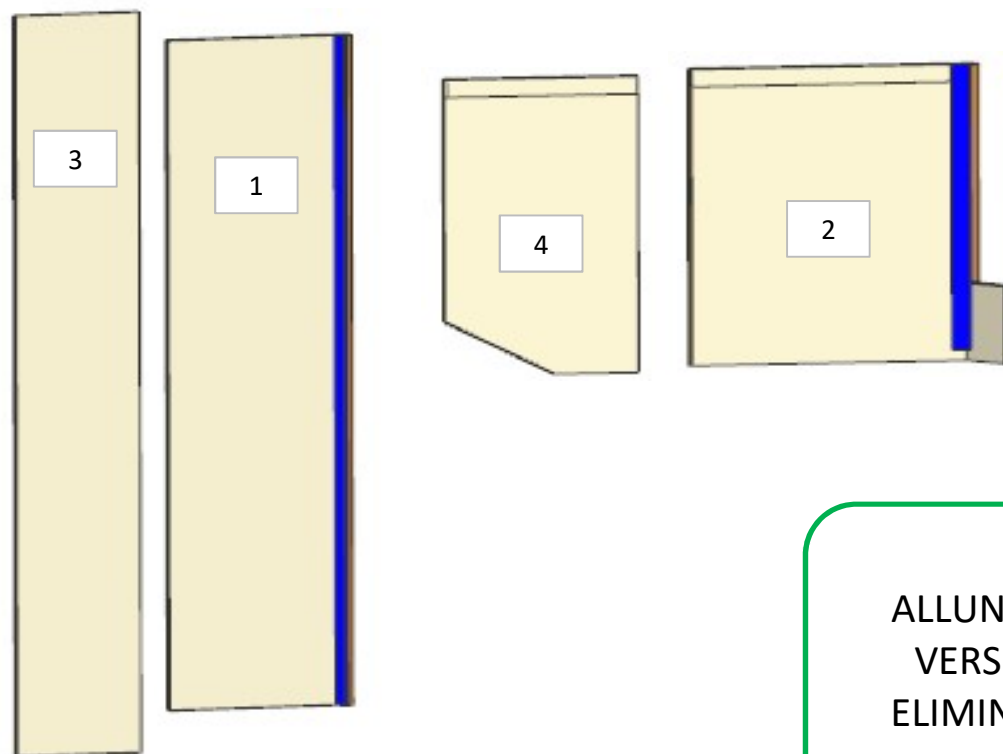

- 1 - L 385 x H 1468 x sp 11
- 2 - L 385 x H 414 x sp 11
- 3 - L 266 x H 1624 x sp 11
- 4 - L 266 x H 414 x sp 11

MOD 216
ALLUNGATI RIVESTIMENTI
VERSO PAVIMENTO ED
ELIMINATI LAMINATI NERI

AZ26M

REV. 01-2023

REV. GR 9

LOCALE	CODICE	DESCRIZIONE COMPONENTE	FINITURA	Q.TA	OPERATORE
CABINA OSPITI DX	AZ26M-MF_RE01\RE02	RIVESTIMENTO PARETI PRUA			Damiano

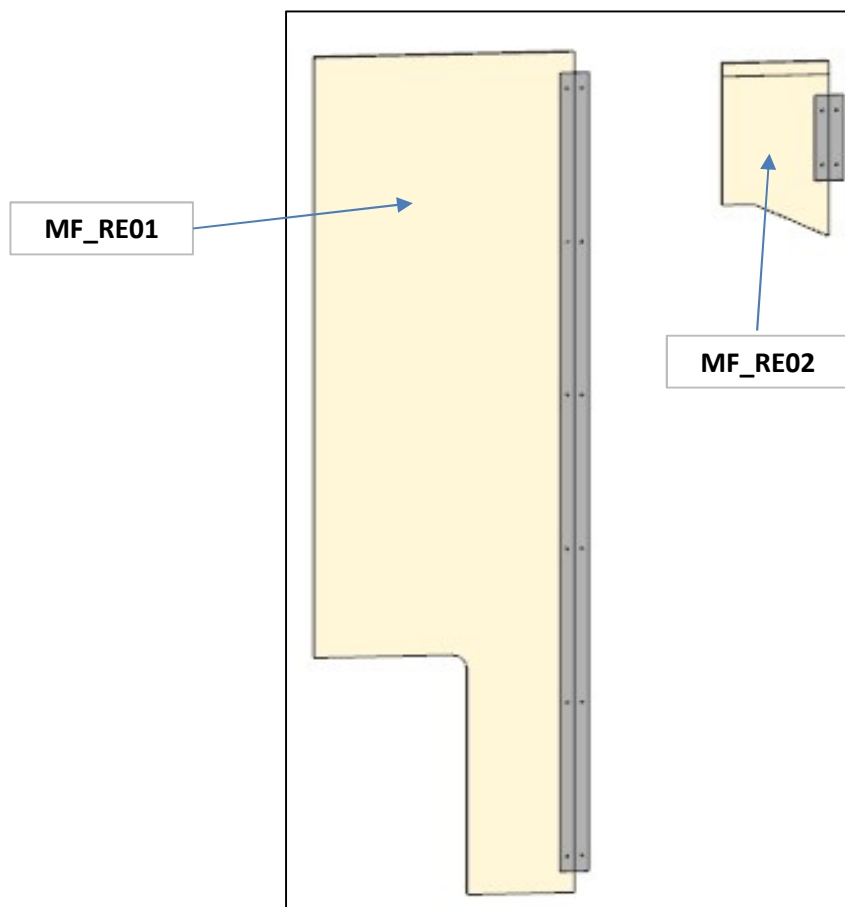

AZ26M

MOD DA GR9

REV. GR 9

LOCALE	CODICE	DESCRIZIONE COMPONENTE	FINITURA	Q.TA	OPERATORE
CABINA OSPITI DX	AZ26M-L01_RE01	RIVESTIMENTO PARETI PRUA	LACCATO BIANCO RAL 9010	2	Damiano

1 - L.448 x H 1623 x sp 10
2 - L.184 x H 305 x sp 10

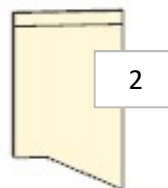
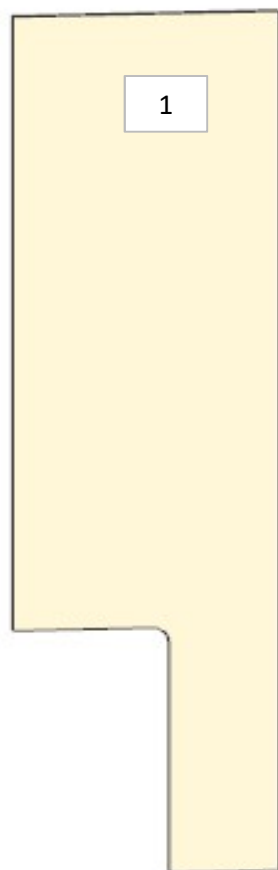

ELEMENTO DA MONTARE con:
A01_RE01
A01_RE02
e spedire con un unico imballo

A01_RE02
A01_RE01

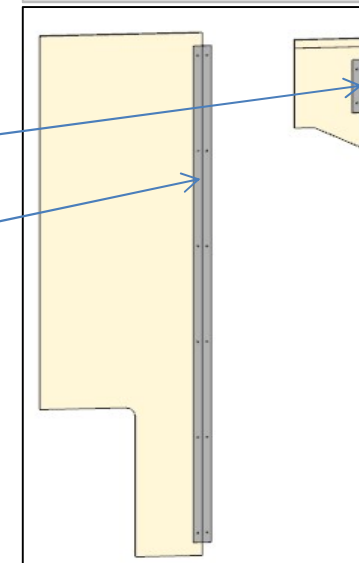

MOD 216
ALLUNGATI RIVESTIMENTI
VERSO PAVIMENTO ED
ELIMINATI LAMINATI NERI

AZ26M

MOD DA GR9

REV. GR 9

LOCALE	CODICE	DESCRIZIONE COMPONENTE	FINITURA	Q.TA	OPERATORE
CABINA OSPITI DX	AZ26M-A01_RE01	RIVESTIMENTO PARETI PRUA	ALLUMINIO	2	Damiano

1 - L 50 x H 1543 x sp 3
2 - L 50 x H 165 x sp 3

1

2

ELEMENTO DA
MONTARE con:
X01_RE01
L01_RE01
e spedire con un unico
imballo

MOD 216
ALLUNGATI RIVESTIMENTI
VERSO PAVIMENTO ED

L01_RE01

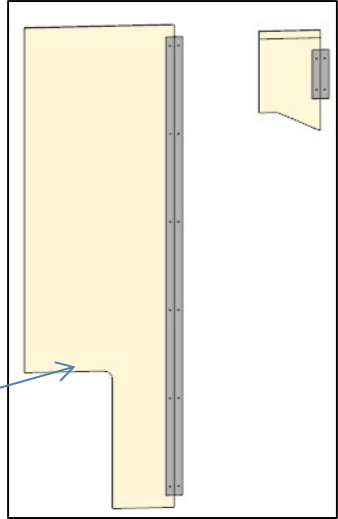

AZ26M

REV. GR 9

LOCALE	CODICE	DESCRIZIONE COMPONENTE	FINITURA	Q.TA	OPERATORE
CABINA OSPITI DX	AZ26M-A02_RE01	RIVESTIMENTO PARETI PRUA	ACCIAIO NERO	2	Damiano

1 - L 451 x H 29,5 x sp 8
2 - L 382 x H 30 x sp 8



AZ26M

REV. 01-2023

REV. GR 9

LOCALE	CODICE	DESCRIZIONE COMPONENTE	FINITURA	Q.TA	OPERATORE
CABINA OSPITI DX	AZ26M-MF_RF01\RF02\ RF03\RF04\ RF05\RF06	RIVESTIMENTO PARETI POPPA			Damiano

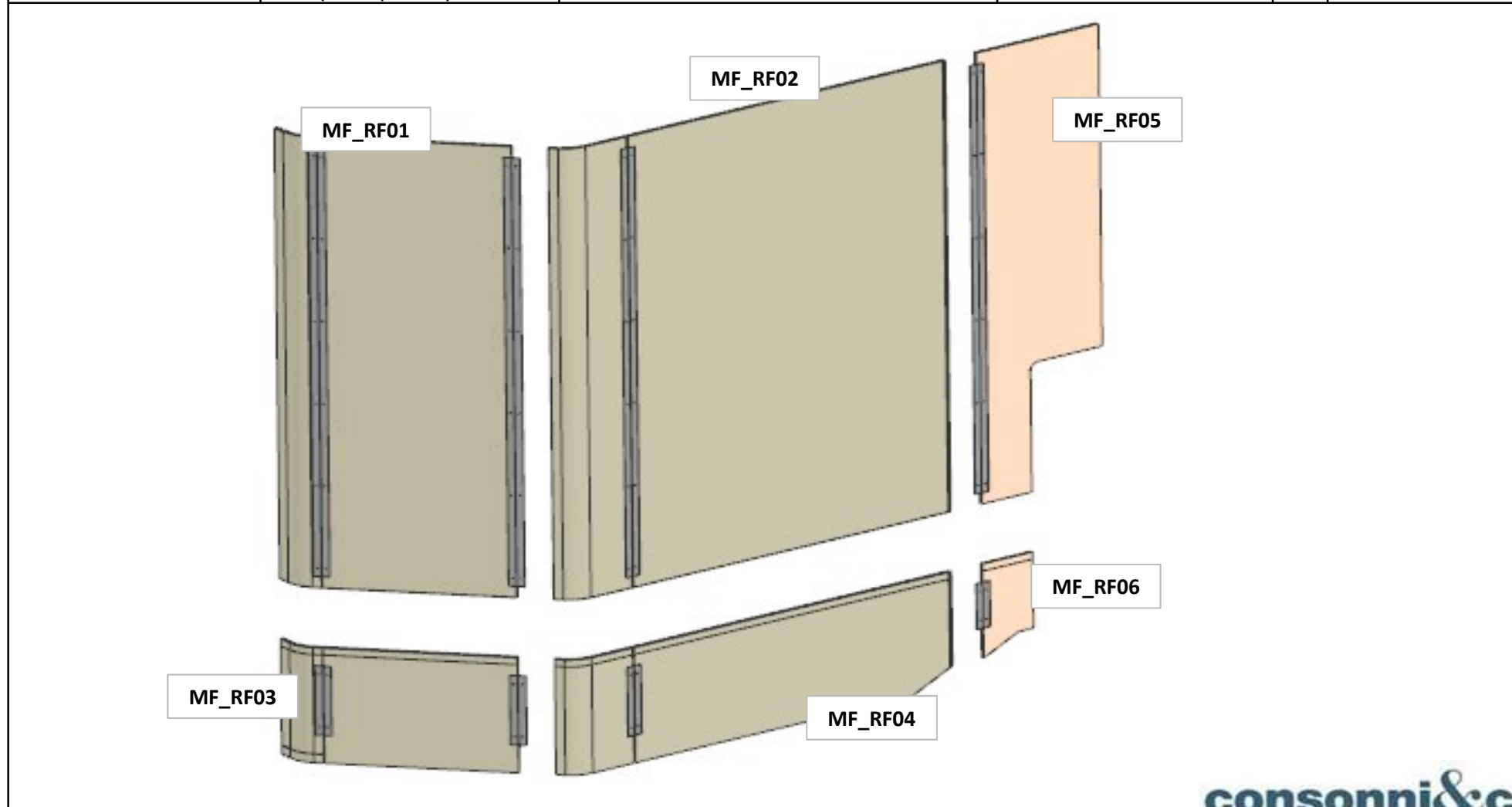

AZ26M

MODV DA GR9

REV. GR9

LOCALE	CODICE	DESCRIZIONE COMPONENTE	FINITURA	Q.TA	OPERATORE
CABINA OSPITI DX	AZ26M-R01_RF01	RIVESTIMENTO PARETI POPPA	LASTRA CHIARA	8	Damiano

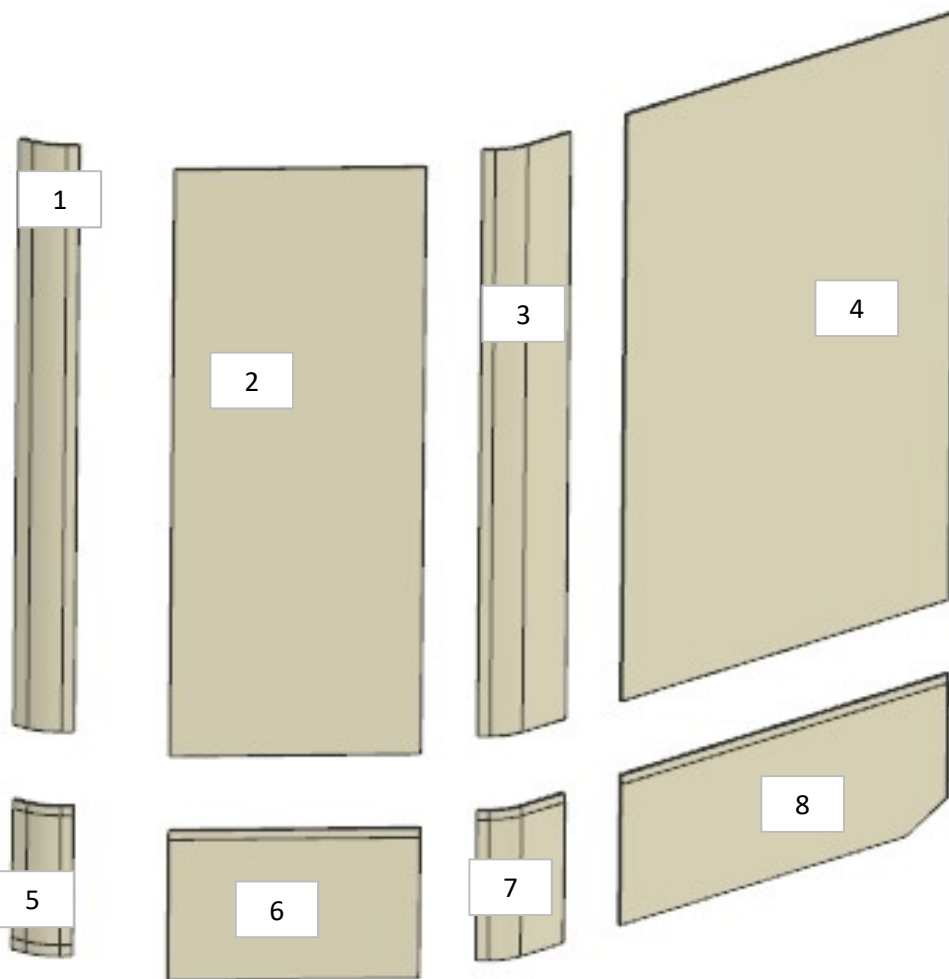

MOD 216
ALLUNGATI
RIVESTIMENTI
VERSO
PAVIMENTO ED
ELIMINATI

- 1 - L. 162 x H.1624 x sp 11
- 2 - L. 596 x H.1624 x sp 11
- 3 - L 272 x H.1624 x sp 11
- 4 - L.1168 x H.1624 x sp 11
- 5 - L. 162 x H.414 x sp 11
- 6 - L. 596 x H.414 x sp 11
- 7 - L 272 x H.414 x sp 11
- 8 - L.1168 x H.414 x sp 11

ELEMENTO DA MONTARE con:
A01_RF01_01 -07
e spedire con un unico imballo

A01_RF01

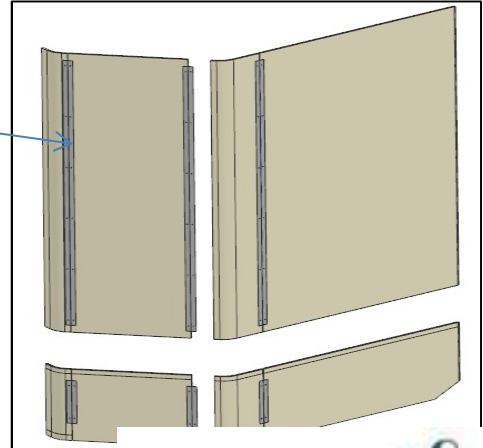

AZ26M

MOD AD GR9

REV. GR 9

LOCALE	CODICE	DESCRIZIONE COMPONENTE	FINITURA	Q.TA	OPERATORE
CABINA OSPITI DX	AZ26M-A01_RF01	RIVESTIMENTO PARETI POPPA	ALLUMINIO	8	Damiano

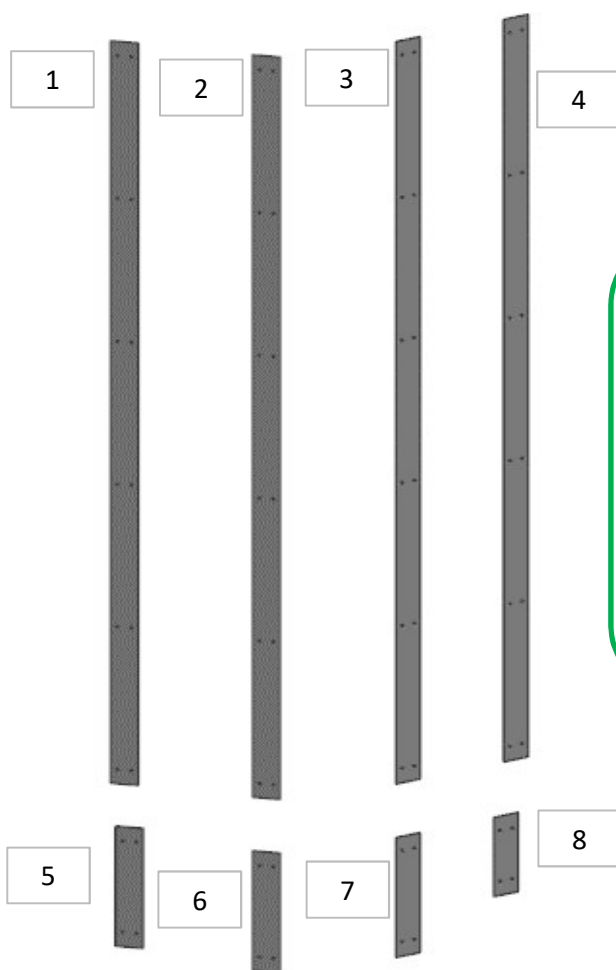

1 - 2 - 3 - 4 - L.50 x H.1543 x sp 2
5 - 6 - 7 - L.50 x H.250 x sp 2
8 - L.50 x H.165 x sp 2

MOD 216
ALLUNGATI
RIVESTIMENTI
VERSO
PAVIMENTO ED
RIMOSSI
LAMINATI NERI

ELEMENTO DA MONTARE con:
R01_RF01
L01_RF01
e spedire con un unico imballo

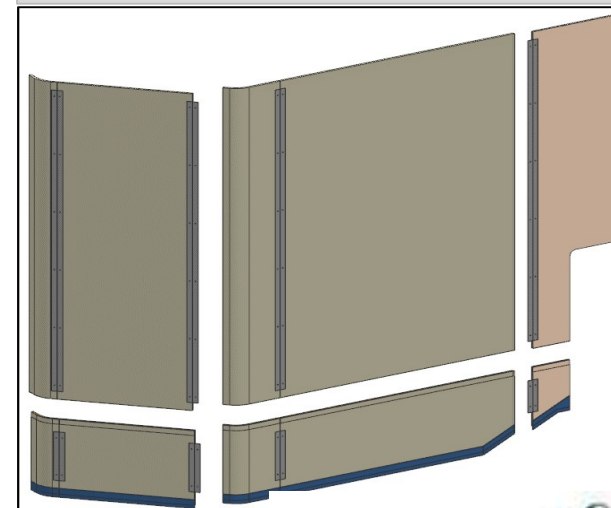

consonni&c

AZ26M

MOD DA GR9

REV. GR 9

LOCALE	CODICE	DESCRIZIONE COMPONENTE	FINITURA	Q.TA	OPERATORE
CABINA OSPITI DX	AZ26M-L01_RF01	RIVESTIMENTO PARETI POPPA	LACCATO BIANCO RAL 9010	2	Damiano

1 - L. 449 x H.1624 x sp 10
2 - L. 184 x H.338 x sp 10

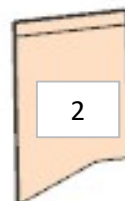
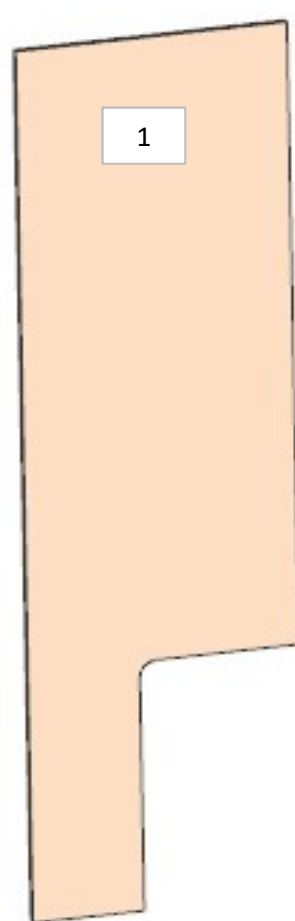

MOD 216
ALLUNGATI RIVESTIMENTI
VERSO PAVIMENTO ED
ELIMINATI LAMINATI NERI

ELEMENTO DA
MONTARE con:
X01_RF01
A01_RF01
e spedire con un
unico imballo

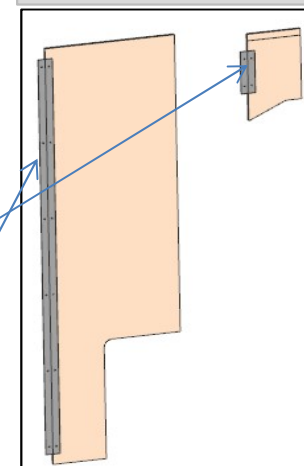

A01_RF08

A01_RF04

AZ26M

REV. GR 9

LOCALE	CODICE	DESCRIZIONE COMPONENTE	FINITURA	Q.TA	OPERATORE
CABINA OSPITI DX	AZ26M-A02_RF01	RIVESTIMENTO PARETI POPPA	ACCIAIO NERO	3	Damiano

- 1 - L 752 x H30 x sp 7
- 2 - L 772 x H30 x sp 7
- 3 - L 852 x H30 x sp 7

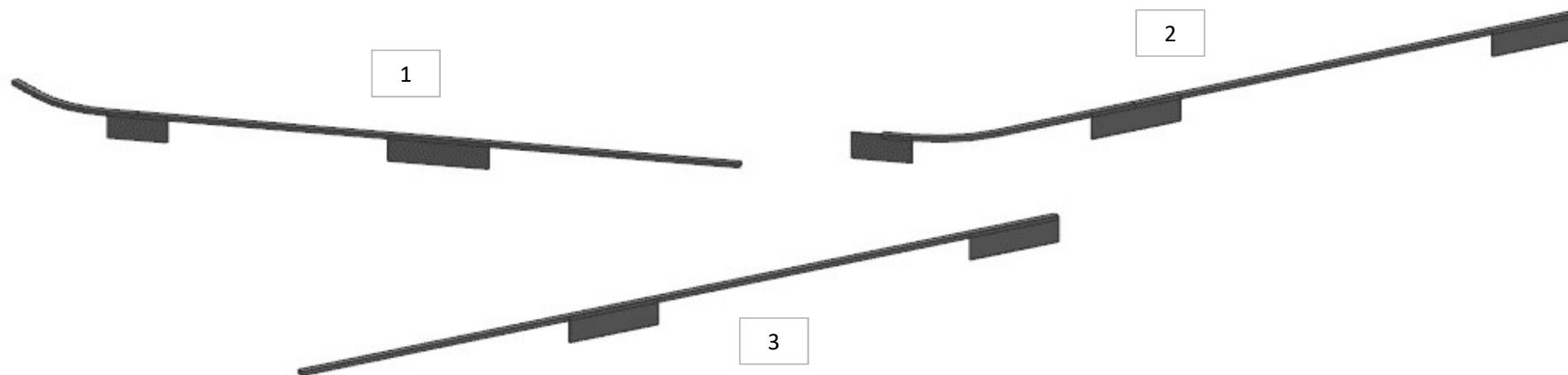

AZ26M

REV. GR 9

LOCALE	CODICE	DESCRIZIONE COMPONENTE	FINITURA	Q.TA	OPERATORE
CABINA OSPITI DX	AZ26M-L01_RH01	RIV. PARETI CENTRO NAVE	LACCATO BIANCO RAL 9010	2	Damiano

1 - L 1050 x H 1624 x sp 10
2 - L 1050 x H 363 x sp 10

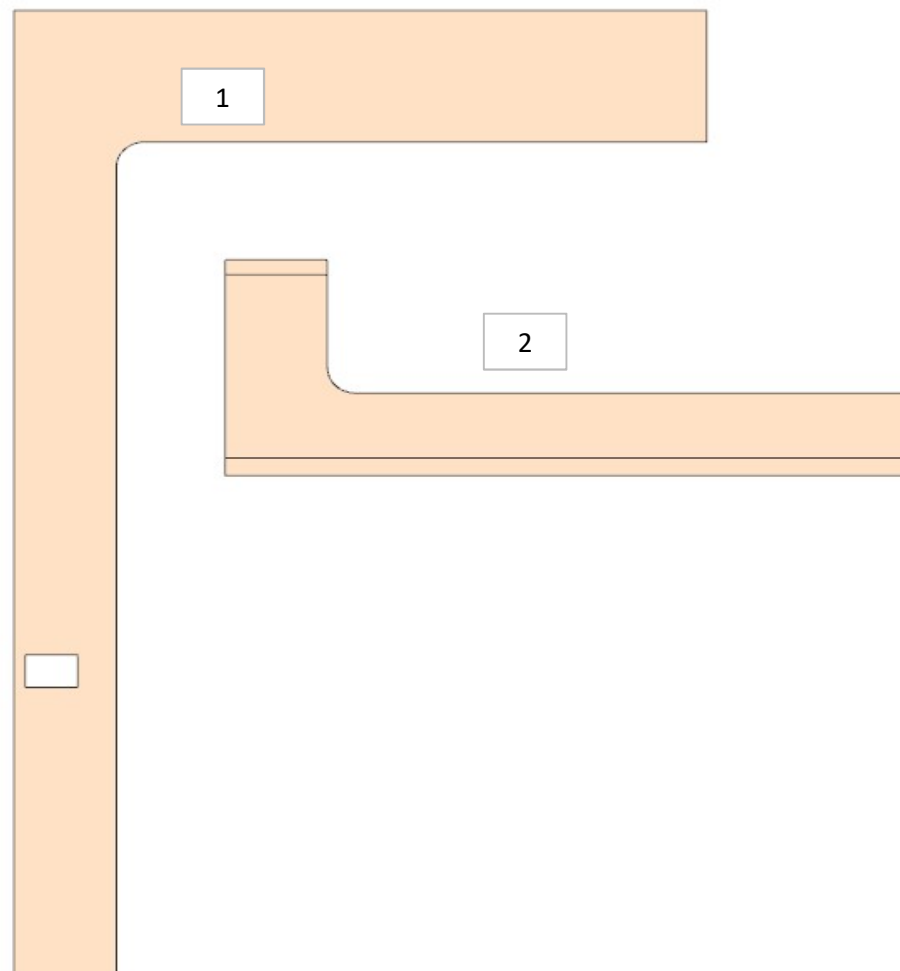

AZ26M

REV. GR 9

LOCALE	CODICE	DESCRIZIONE COMPONENTE	FINITURA	Q.TA	OPERATORE
CABINA OSPITI DX	AZ26M-L02_RH01	RIV. PARETI CENTRO NAVE	LACCATO BRONZO	1	Damiano

1 - L.1050 x H 64 x sp 3



AZ26M

REV. GR 9

LOCALE	CODICE	DESCRIZIONE COMPONENTE	FINITURA	Q.TA	OPERATORE
CABINA OSPITI DX	AZ26M-A01_RH01	RIV. PARETI CENTRO NAVE	ACCIAIO NERO	1	Damiano

1 - L 155 x H 30 x sp 7

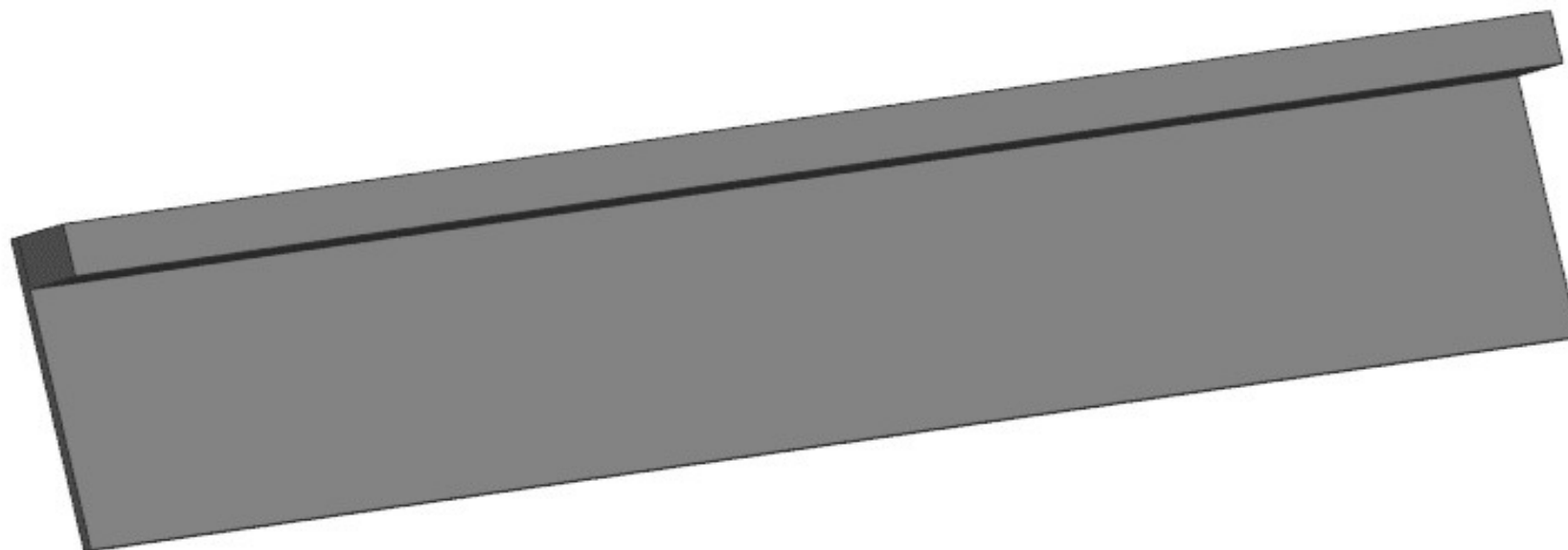

AZ26M

REV. 01-2023

REV. GR9

LOCALE	CODICE	DESCRIZIONE COMPONENTE	FINITURA	Q.TA	OPERATORE
CABINA OSPITI DX	AZ26M-R01_RM01	ARMADIO	LASTRA CHIARA	3	Damiano

- 1 - L.570 x H.1777 x sp 25
- 2 - L.501 x H.1467 x sp 25
- 3 - L.212 x H.2014 x sp 25

**DIVENTATA ANTA UNICA E
MODIFICATO COPERTURA
INTERNA**

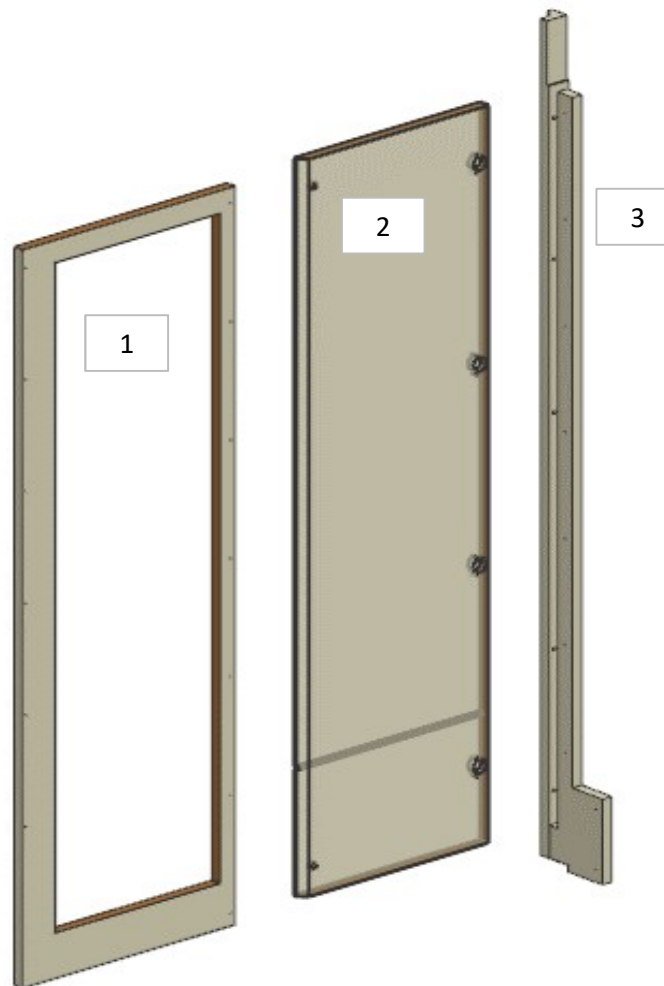

AZ26M

REV. GR 9

LOCALE	CODICE	DESCRIZIONE COMPONENTE	FINITURA	Q.TA	OPERATORE
CABINA OSPITI DX	AZ26M-A01_RM01	ARMADIO	ACCIAIO NERO	1	Damiano

1 - L 499 x H 5 x sp 2

**ELEMENTO DA
MONTARE con:
RM01
R01_RM01
e spedire con un
unico imballo**

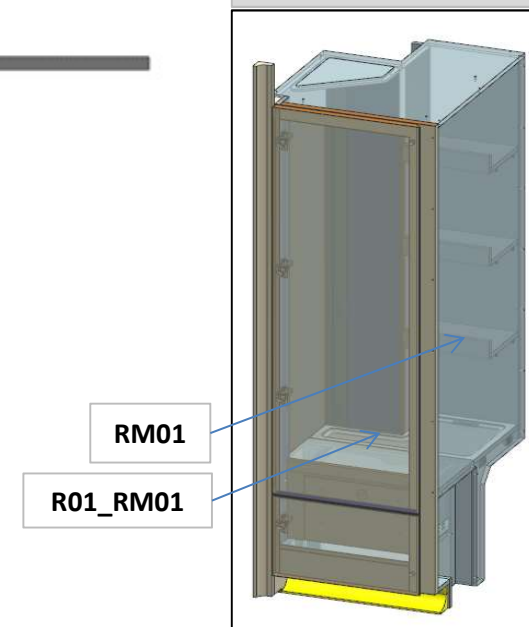

consonni&c

AZ26M

MOD GR9

REV. GR 9

LOCALE	CODICE	DESCRIZIONE COMPONENTE	FINITURA	Q.TA	OPERATORE
CABINA OSPITI SX	AZ26M-MF_LE01\LE02	STRUTTURA TESTATA LETTO			Damiano

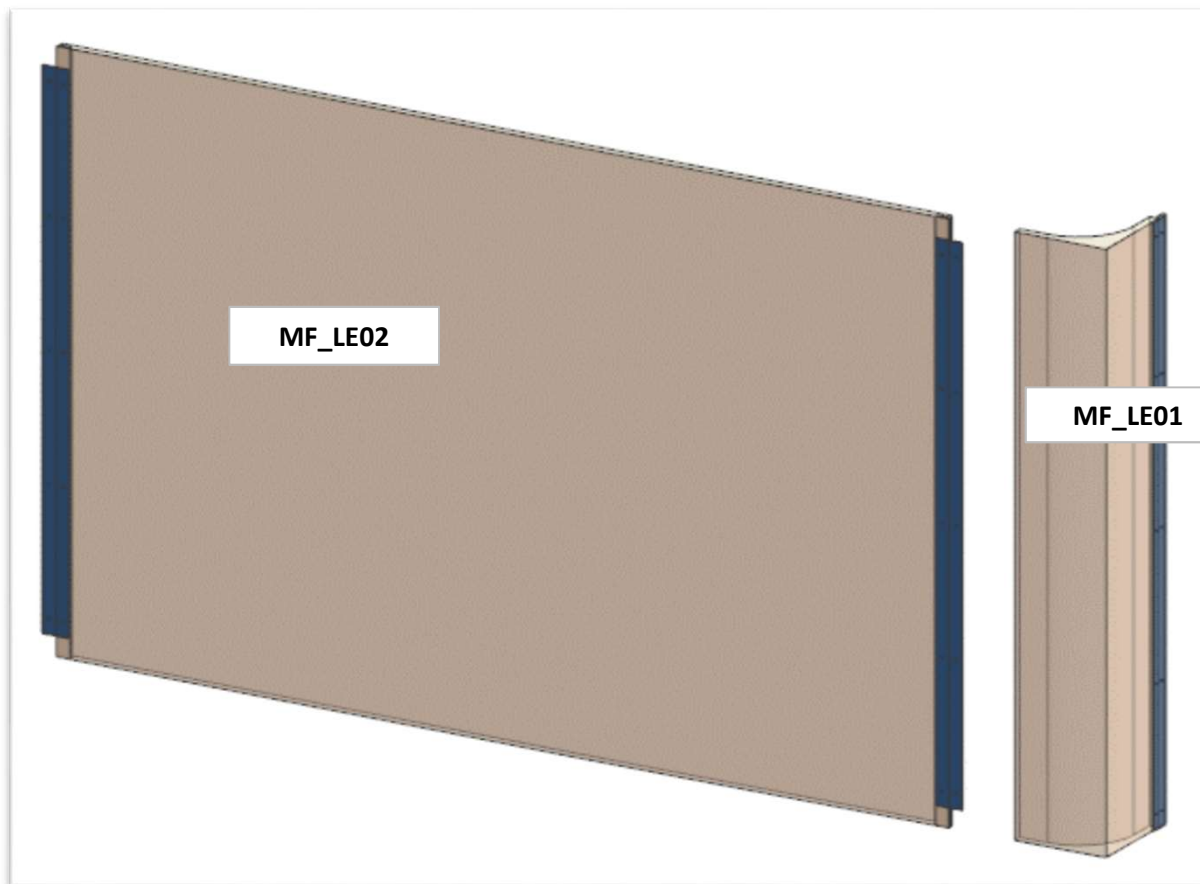

AZ26M

MOD GR9

REV. GR 9

LOCALE	CODICE	DESCRIZIONE COMPONENTE	FINITURA	Q.TA	OPERATORE
CABINA OSPITI SX	AZ26M-L01_LE01	STRUTTURA TESTATA LETTO	LACCATO BIANCO RAL 9010	6	Damiano

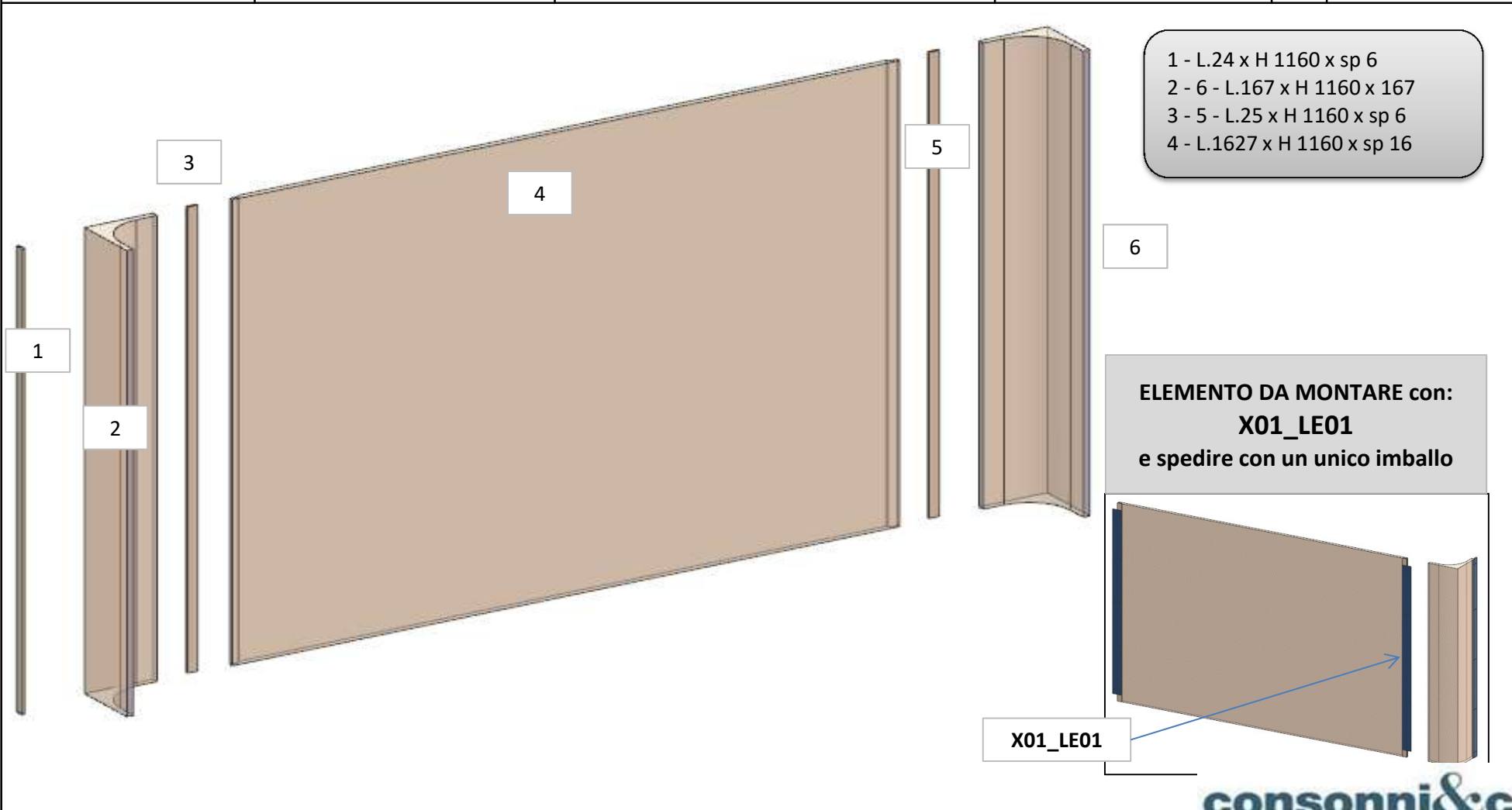

consonni&c

AZ26M

MOD GR9

REV. GR 9

LOCALE	CODICE	DESCRIZIONE COMPONENTE	FINITURA	Q.TA	OPERATORE
CABINA OSPITI SX	AZ26M-X01_LE01	STRUTTURA TESTATA LETTO	LAMINATO NERO	3	Damiano

1 - L.40 x H 1160 x sp 3
2 - 3 - L.50 x H 1080 x sp 3

MOD AZ 216
RIMOSI TUTTI I LAMINATI
ALLA BASE DEI
RIVESTIMENTI

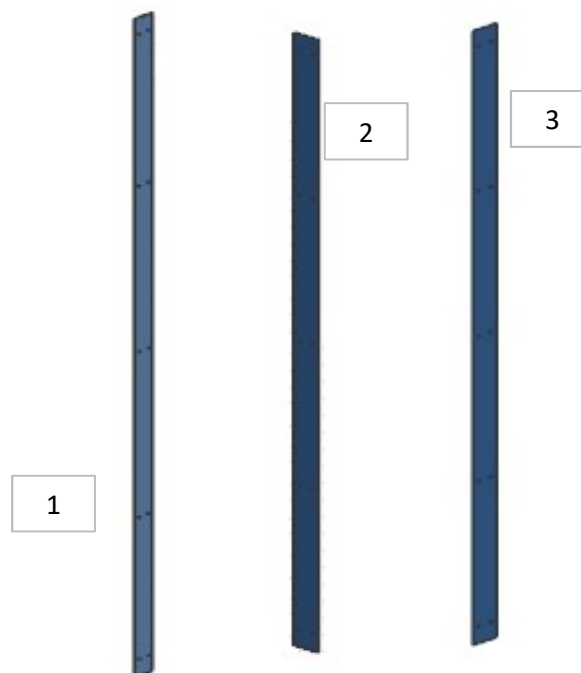

ELEMENTO DA MONTARE con:
L01_LE01
e spedire con un unico imballo

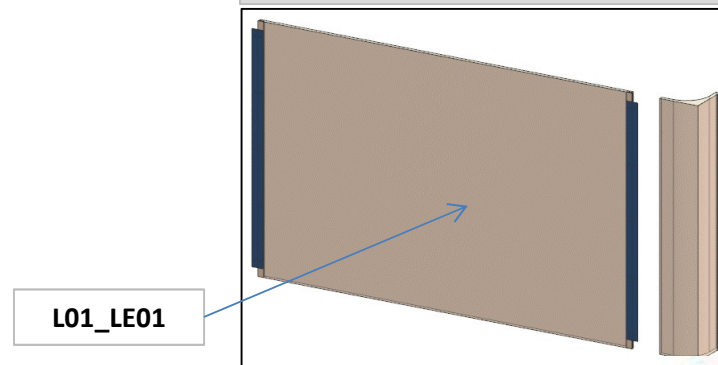

consonni&c

AZ26M

REV. GR 9

LOCALE	CODICE	DESCRIZIONE COMPONENTE	FINITURA	Q.TA	OPERATORE
CABINA OSPITI SX	AZ26M-MF_LF01\LF02\ LF03\LF04	RIVESTIMENTI PARETI CENTRO NAVE			Damiano

MF_LF02

MF_LF01

MF_LF04

MF_LF03

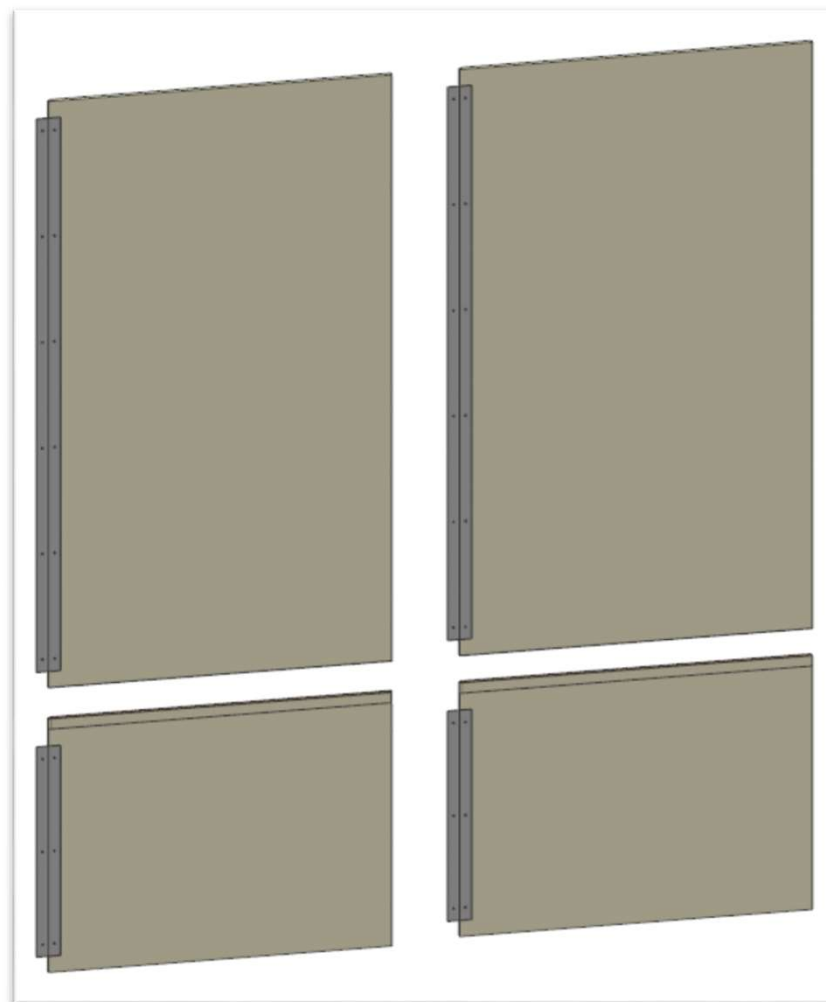

AZ26M

REV. GR 9

LOCALE	CODICE	DESCRIZIONE COMPONENTE	FINITURA	Q.TA	OPERATORE
CABINA OSPITI SX	AZ26M-R01_LF01	RIVESTIMENTI PARETI CENTRO NAVE	LASTRA CHIARA	4	Damiano

- 1 - L. 730 x H 1419 x sp 11
- 2 - L. 713 x H 1419 x sp 11
- 3 - L. 730 x H 615 x sp 11
- 4 - L. 713 x H 615 x sp 11

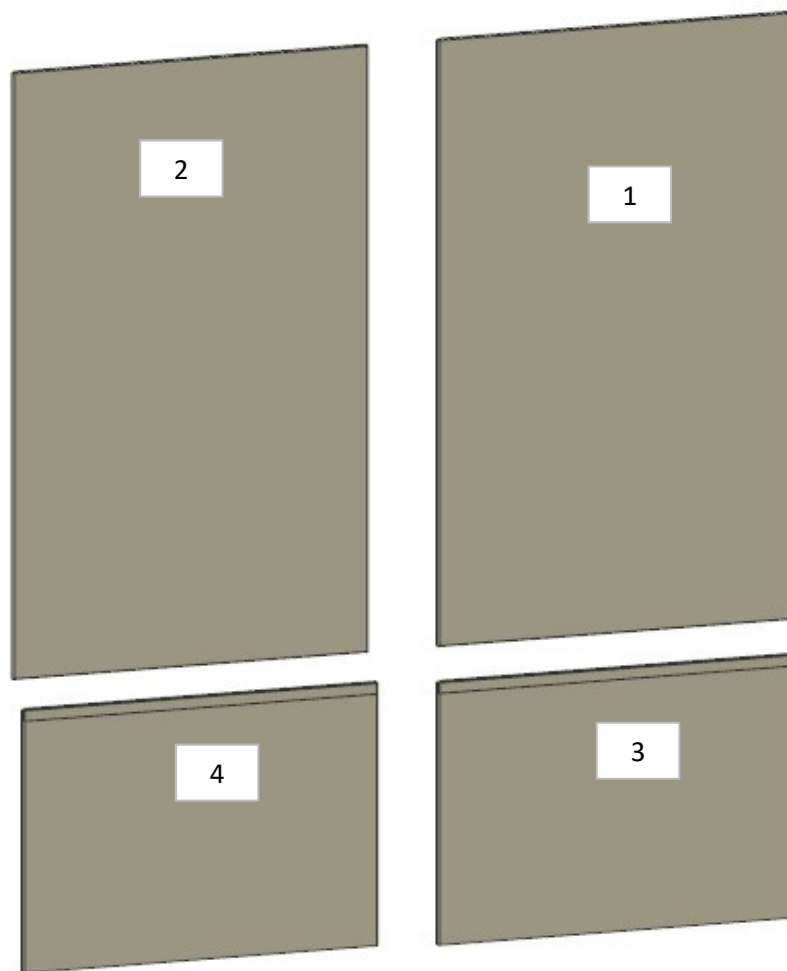

ELEMENTO DA MONTARE
con:
A01_LF01
e spedire con un unico
imballo

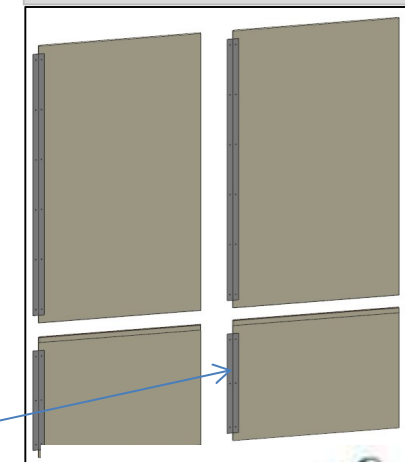

A01_LF01

AZ26M

REV. GR 9

LOCALE	CODICE	DESCRIZIONE COMPONENTE	FINITURA	Q.TA	OPERATORE
CABINA OSPITI SX	AZ26M-A01_LF01	RIVESTIMENTI PARETI CENTRO NAVE	ALLUMINIO	4	Damiano

1 - 2 - L.50 x H 1339 x sp 2
3 - 4 - L.50 x H 509 x sp 2

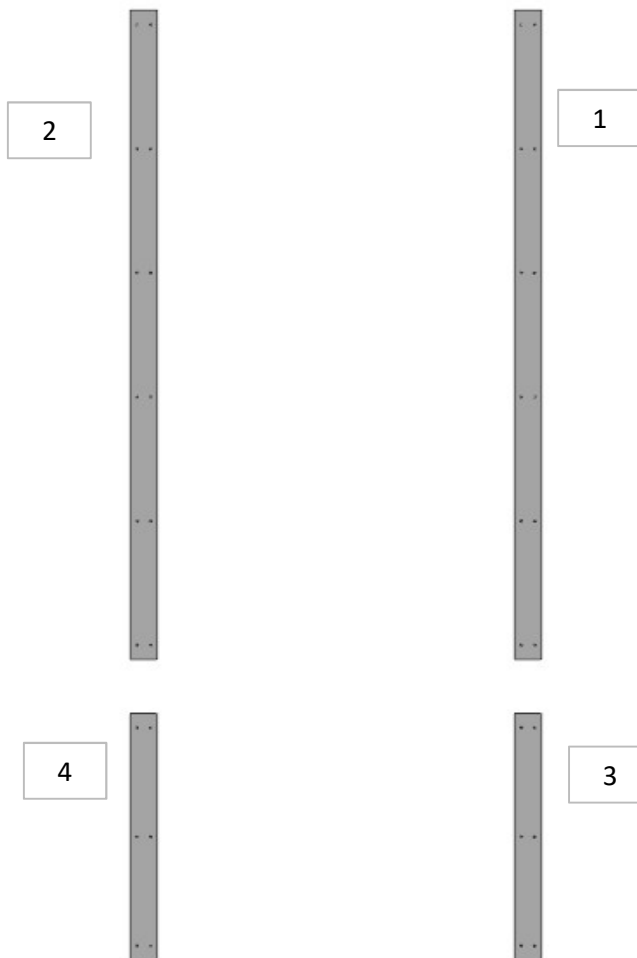

ELEMENTO DA MONTARE
con:
R01_LF01
e spedire con un unico
imballo

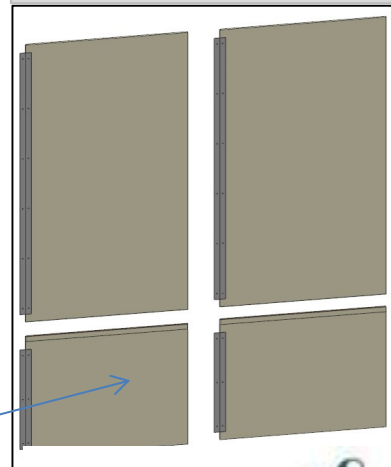

R01_LF01

consonni&c

AZ26M

MOD DA GR10

REV. GR 10

LOCALE	CODICE	DESCRIZIONE COMPONENTE	FINITURA	Q.TA	OPERATORE
CABINA OSPITI SX	AZ26M-L01_LF01	RIVESTIMENTI PARETI CENTRO NAVE	LACCATO BIANCO RAL 9010	3	Damiano

- 1 - L 305 x H 1419 x sp 10
- 2 - L 100 x H 615 x sp 10
- 3 - L.24 x H 1160 x sp 6

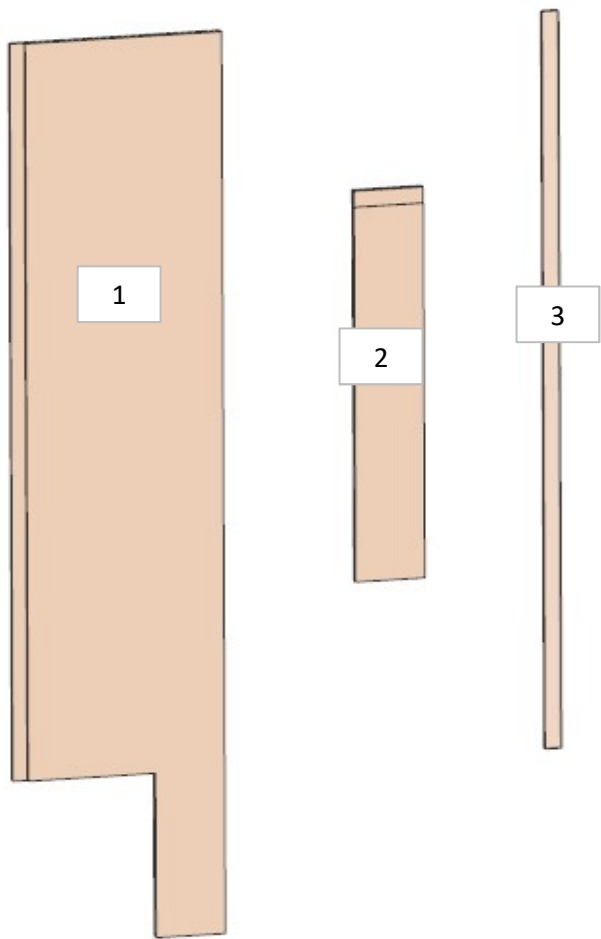

MOD INT 46
AGGIUNTO UN
PEZO

AZ26M

DA MAT. 14

REV. GR 9

LOCALE	CODICE	DESCRIZIONE COMPONENTE	FINITURA	Q.TA	OPERATORE
CABINA OSPITI SX	AZ26M-A02_LF01	RIVESTIMENTI PARETI CENTRO NAVE	ACCIAIO NERO	1	Damiano

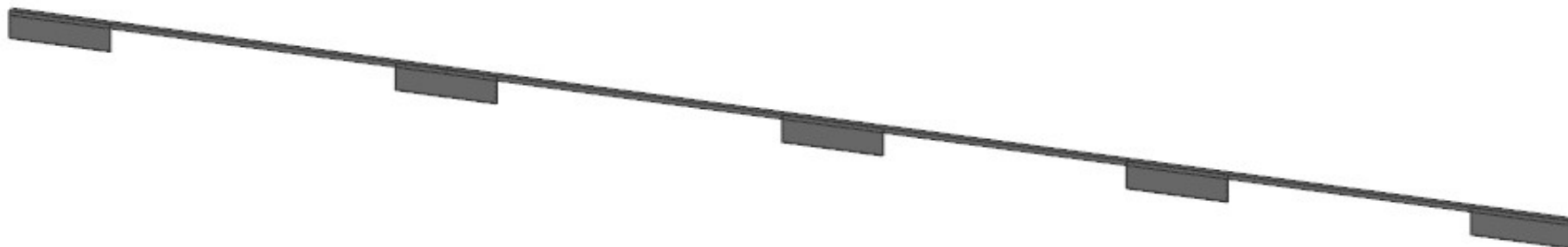

AZ26M

GR9

REV. GR 9

LOCALE	CODICE	DESCRIZIONE COMPONENTE	FINITURA	Q.TA	OPERATORE
CABINA OSPITI SX	AZ26M-R01_LL01	RIVESTIMENTI PARETI PRUA	LASTRA CHIARA	4	Damiano

- 1 - L.315 x H.1419 x sp 11
- 2 - L.315 x H.621 x sp 11
- 3 - L.186 x H.1419 x sp 11
- 4 - L.354 x H 621 x sp 11

RIDOTTO LARGHEZZA
PZ. 3 e 4

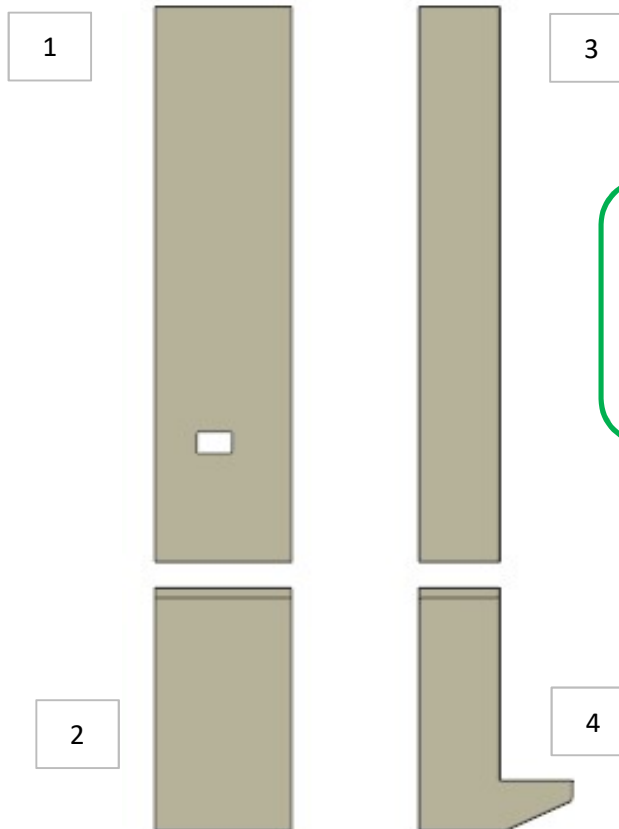

MOD AZ 216
RIMOSI TUTTI I LAMINATI
ALA BASE DEI
RIVEZSTIMENTI

AZ26M

REV. GR 9

LOCALE	CODICE	DESCRIZIONE COMPONENTE	FINITURA	Q.TA	OPERATORE
CABINA OSPITI SX	AZ26M-A01_LL01	RIVESTIMENTI PARETI PRUA	ACCIAIO NERO	2	Damiano

1 - L. 315 x H.30 x sp 8
2 - L. 186 x H.30 x sp 8

RIDOTTO LARGHEZZA PZ. 2

1



2



AZ26M

DA MAT. 11

REV. GR 9

LOCALE	CODICE	DESCRIZIONE COMPONENTE	FINITURA	Q.TA	OPERATORE
CABINA OSPITI SX	AZ26M-MF_LP01	LETTO PULLMAN - OPT			Damiano



AZ26M

DA MAT. 11

REV. GR 9

LOCALE	CODICE	DESCRIZIONE COMPONENTE	FINITURA	Q.TA	OPERATORE
CABINA OSPITI SX	AZ26M-LP01	LETTO PULLMAN - OPT	OKOUME' GREZZO	1	Damiano

1 - L.1918 x H 836 x sp 10

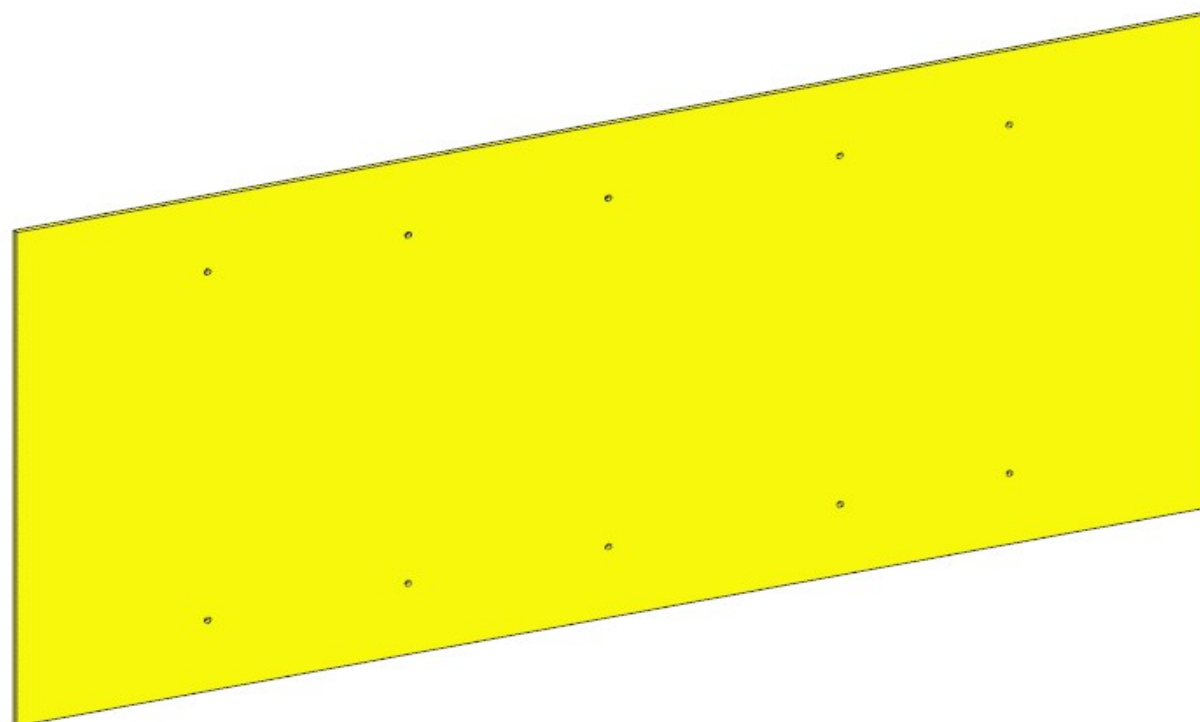

ELEMENTO DA MONTARE con:
R01_LP01
A01_LP01

A01_LP01

R01_LP01

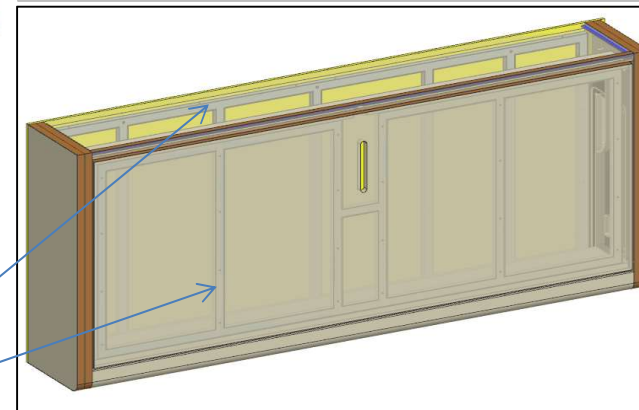

AZ26M

DA MAT. 11

REV. GR 9

LOCALE	CODICE	DESCRIZIONE COMPONENTE	FINITURA	Q.TA	OPERATORE
CABINA OSPITI SX	AZ26M-R01_LP01	LETTO PULLMAN - OPT	LASTRA CHIARA	18	Damiano

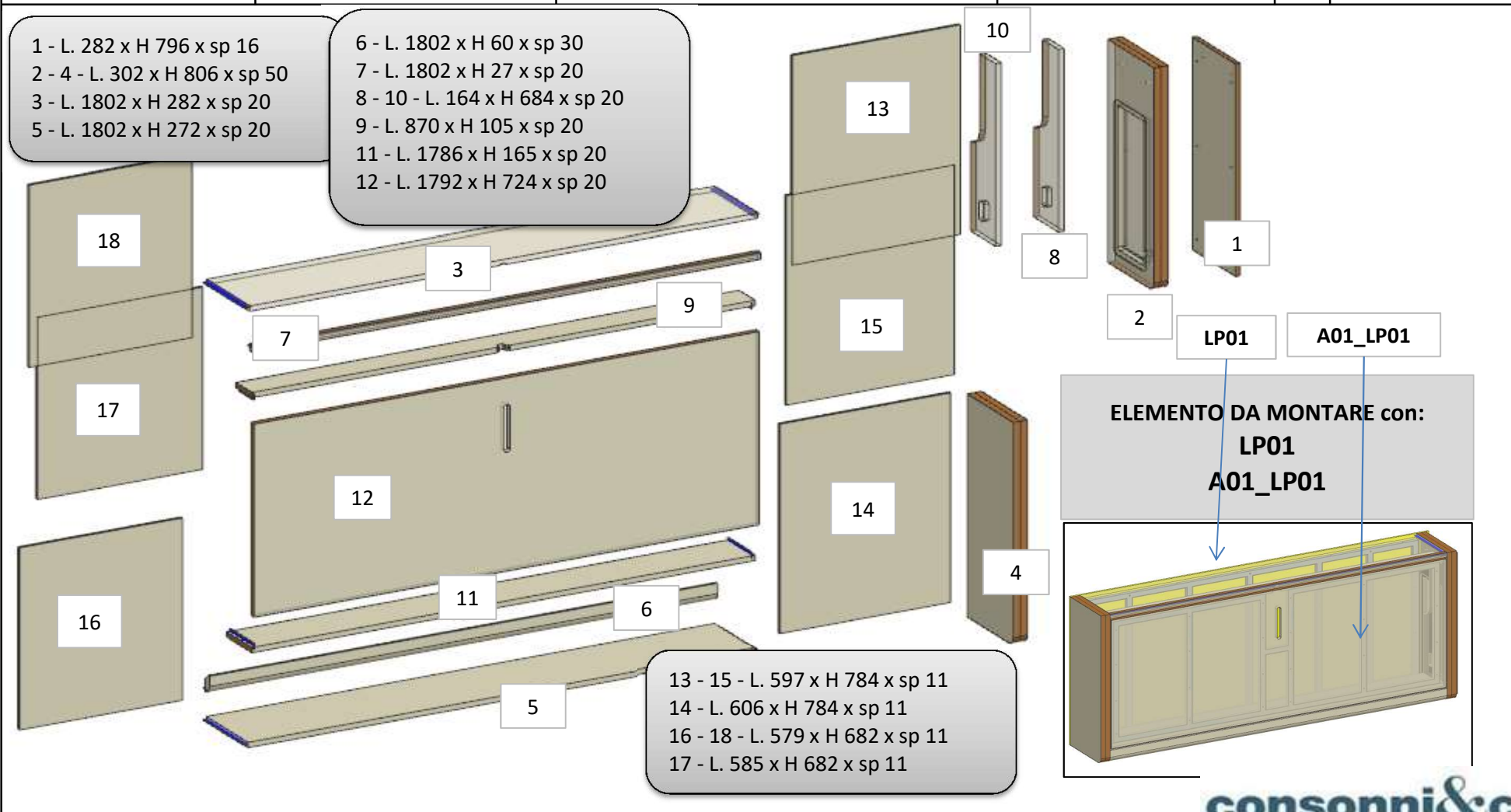

AZ26M

DA MAT. 11

REV. GR 9

LOCALE	CODICE	DESCRIZIONE COMPONENTE	FINITURA	Q.TA	OPERATORE
CABINA OSPITI SX	AZ26M-A01_LP01	LETTO PULLMAN - OPT	ACCIAIO	7	Damiano

1 - L. 1746 x H 684 x sp 20
 2 - L. 1802 x H 786 x sp 20
 3 - 4 - 5 - 6 - 7 - L. 60 x H 786 x sp 2

ELEMENTO DA MONTARE con:
R01_LP01
LP01

LP01
 R01_LP01

consonni&c

AZ26M

REV. GR 9

LOCALE	CODICE	DESCRIZIONE COMPONENTE	FINITURA	Q.TA	OPERATORE
BAGNO OSPITI DX	AZ26M-MG_ZF01\ZF02	RIVESTIMENTI ZONA LAVELLO			Damiano

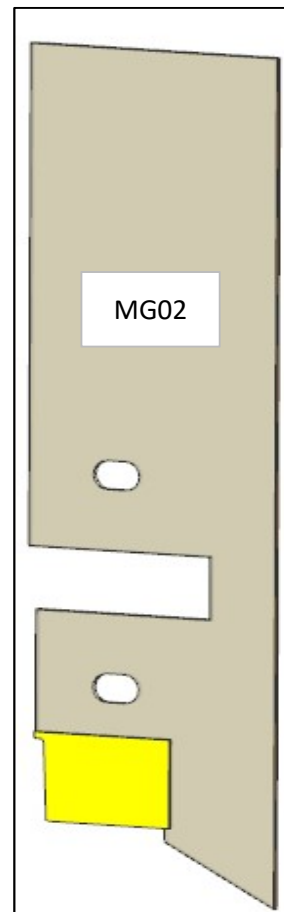
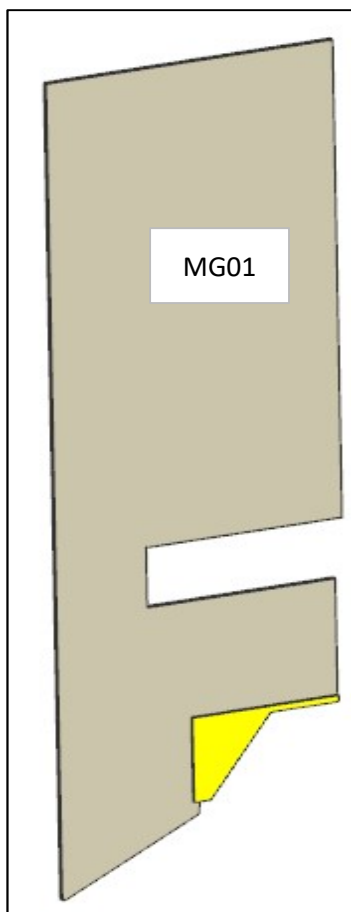

AZ26M

REV. 01-2023

REV. GR 9

LOCALE	CODICE	DESCRIZIONE COMPONENTE	FINITURA	Q.TA	OPERATORE
BAGNO OSPITI DX	AZ26M-R01_ZF01	RIVESTIMENTI ZONA LAVELLO	LASTRA CHIARA	12	Damiano

ELIMINATI PZ. 5 e 12
AGGIUNTI MG ZF01
MG ZF02

- 1 - L.646 x H.2028 x sp 11
- 2 - L.330 x H.210 x sp 6
- 3 - 10 - L.76 x H.1180 x 71
- 4 - 11 - L.76 x H.288 x 71
- 5- L. 330 x H.210 x sp 6
- 6 - L.572 x H.237 x sp 16
- 7 - L 572 x H.200 x sp 16
- 8 - L.571 x H.288 x sp 16
- 9 - L.714 x H.79 x sp 16
- 12 - L.602 x H.2009 x sp 11

FERRAMENTA:
 N° 4 - FITLOCK MASCHIO

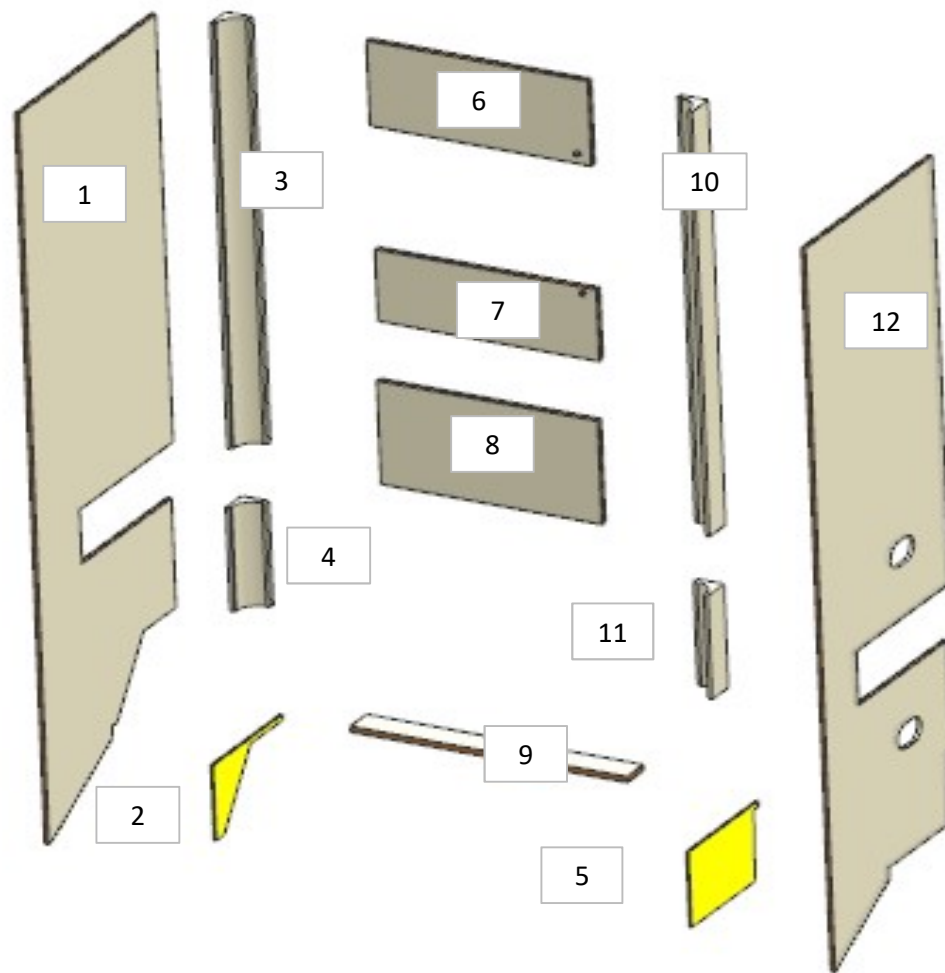

ELEMENTO DA MONTARE con:
 R01_ZF01_01/02
 RI01_ZF01_05/12
 e spedire con un unico imballo

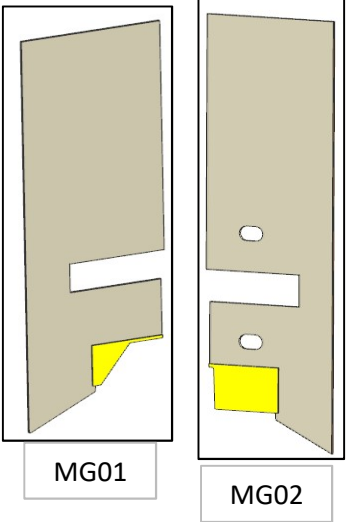

AZ26M

DA MAT. 11

REV. GR 9

LOCALE	CODICE	DESCRIZIONE COMPONENTE	FINITURA	Q.TA	OPERATORE
BAGNO OSPITI DX	AZ26M-L01_ZF01	RIVESTIMENTI ZONA LAVELLO	LACCATO BIANCO RAL 9010	7	Damiano

- 1 - L. 510 x H 94 x sp 10
- 2 - L. 510 x H 37 x sp 10
- 3 - L. 310 x H 2029 x sp 10
- 4 - 6 - L. 121 x H 2029 x 121
- 5 - L. 471 x H 2029 x sp 10
- 7 - L. 203 x H2029 x sp 10

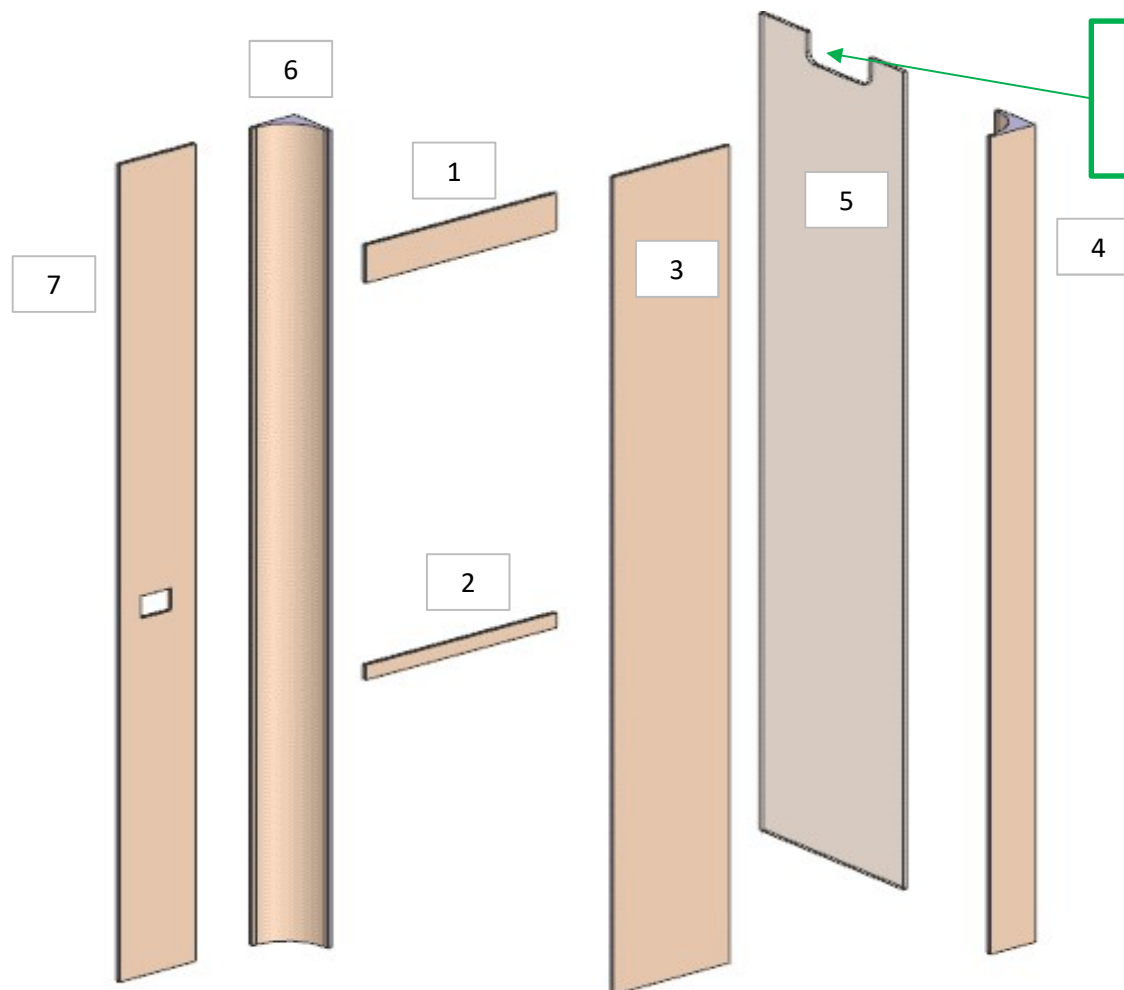

AZ26M

REV. GR 9

LOCALE	CODICE	DESCRIZIONE COMPONENTE	FINITURA	Q.TA	OPERATORE
BAGNO OSPITI DX	AZ26M-L01_ZL01	RIVESTIMENTI ZONA DOCCIA	LACCATO BIANCO RAL 9010	9	Damiano

- 1 - L.972 x H.2033 x sp 10
- 2 - L.510 x H.94 x sp 10
- 3 - L.510 x H.41 x sp 10

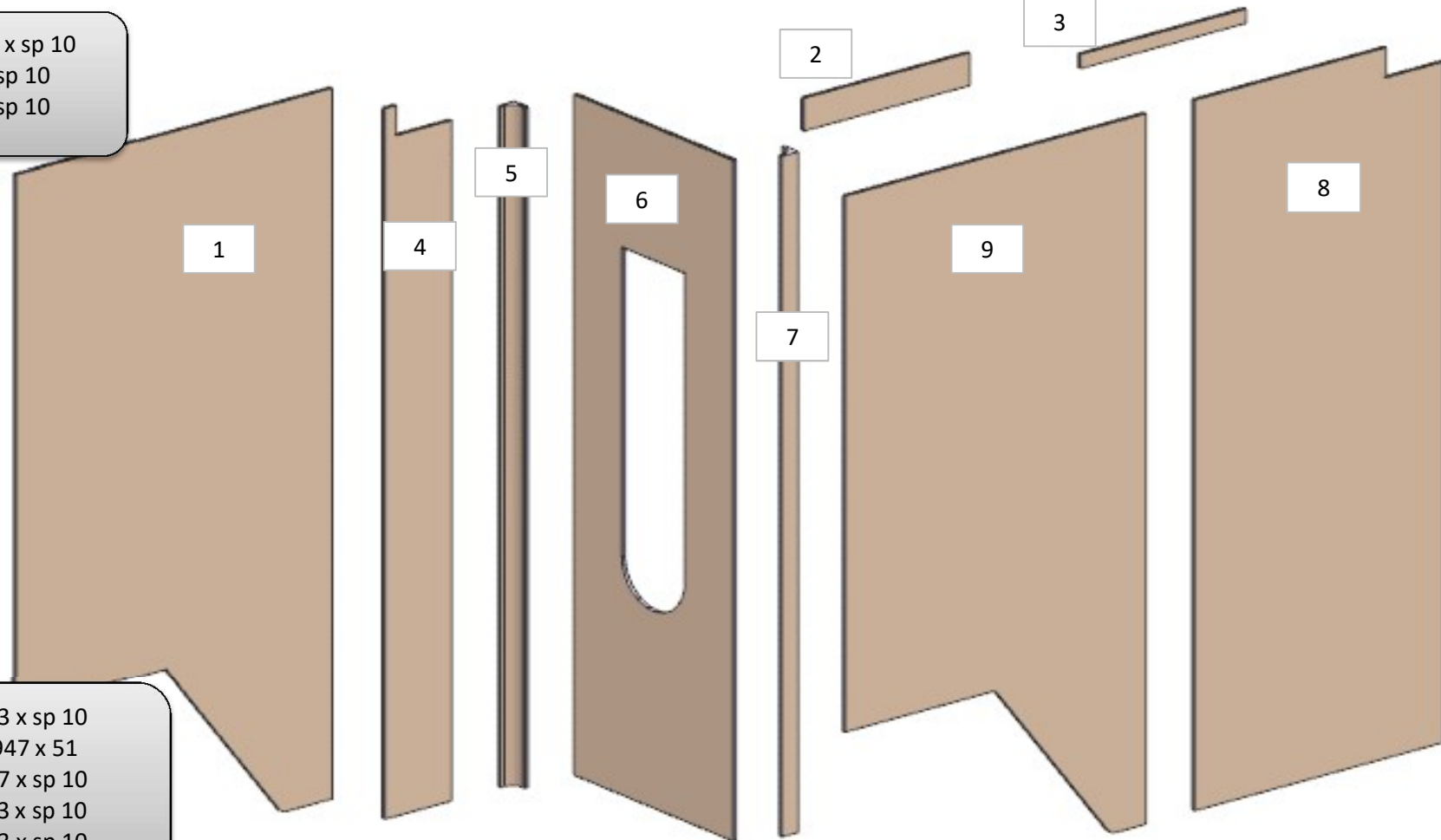

- 4 - L.206 x H.2033 x sp 10
- 5 - 7 - L.51 x H.1947 x 51
- 6 - L.601 x H.1947 x sp 10
- 8 - L.764 x H.2033 x sp 10
- 9 - L.924 x H.2033 x sp 10

AZ26M

MOD DA GR9

REV. GR 9

LOCALE	CODICE	DESCRIZIONE COMPONENTE	FINITURA	Q.TA	OPERATORE
BAGNO OSPITI DX	AZ26M-MG_ZM01\ZM02	RIV. SOTTO SEDUTA DOCCIA			Damiano

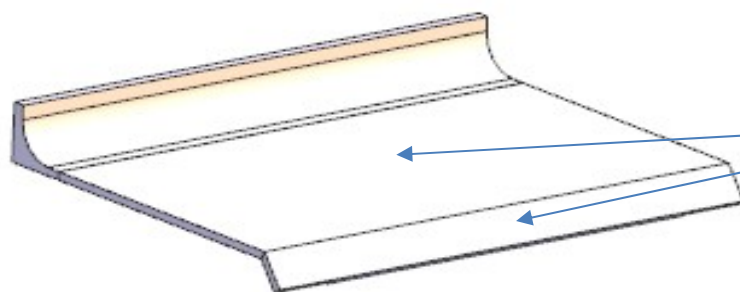

MG_ZM01

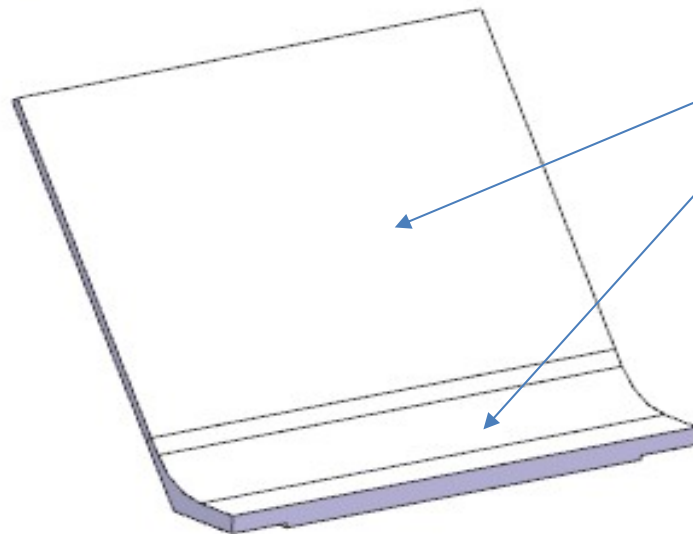

MG_ZM02

MOD AZ 227 GR9
AGGIUNTI DUE
MONTATI GREZZI DA
ASSEMBLARE DIPO LA
LACCATURA

AZ26M

MOD DA GR9

REV. GR 9

LOCALE	CODICE	DESCRIZIONE COMPONENTE	FINITURA	Q.TA	OPERATORE
BAGNO OSPITI DX	AZ26M-L01_ZM01	RIV. SOTTO SEDUTA DOCCIA	LACCATO BIANCO RAL 9010	4	Damiano

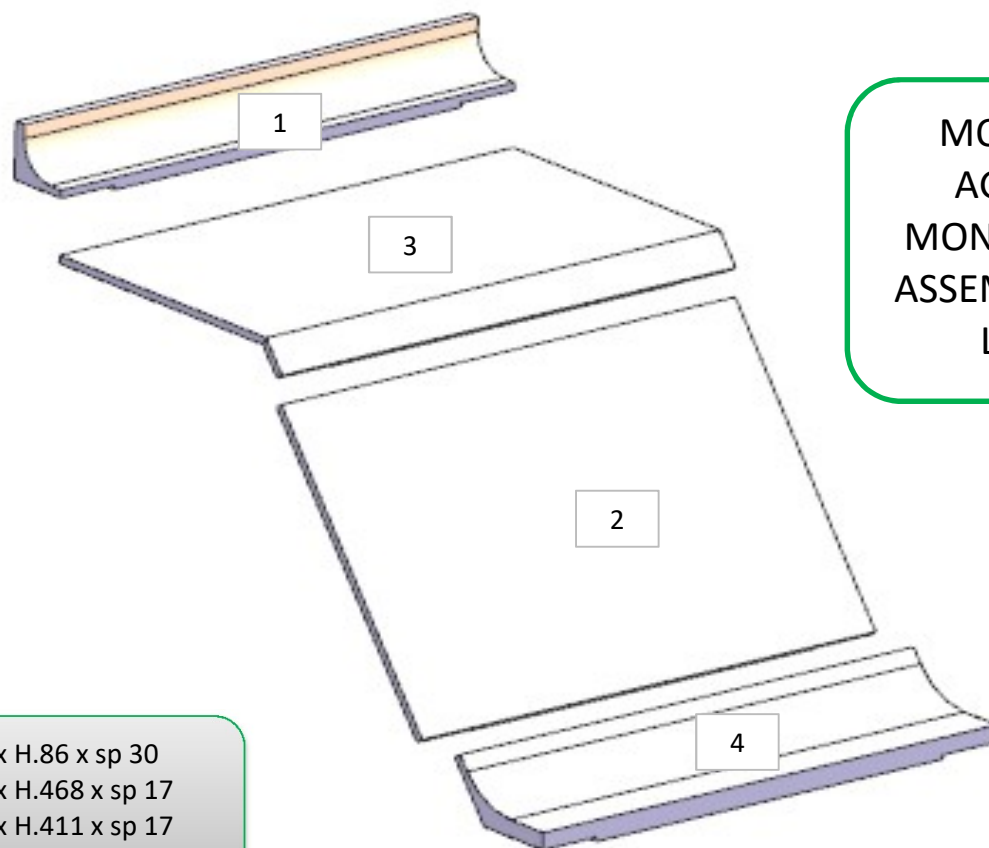

MOD AZ 227 GR9
AGGIUNTI DUE
MONTATI GREZZI DA
ASSEMBLARE DIPO LA
LACCATURA

- 1 - L.683 x H.86 x sp 30
- 2 - L.683 x H.468 x sp 17
- 3 - L.683 x H.411 x sp 17
- 4 - L.683 x H.181 x sp 30

ELEMENTO DA
MONTARE:
MG_ZM01
e spedire con un
unico imballo

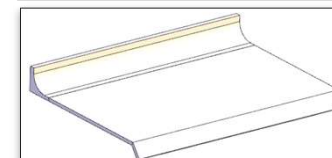

ELEMENTO DA
MONTARE:
MG_ZM02
e spedire con un unico

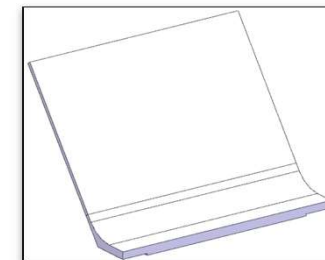

AZ26M

REV. GR 9

LOCALE	CODICE	DESCRIZIONE COMPONENTE	FINITURA	Q.TA	OPERATORE
BAGNO OSPITI DX	AZ26M-L01_ZN01	RIV. OBLO' MURATA	LACCATO BIANCO RAL 9010	1	Damiano

1 - L 689 x H.1452 x sp 16

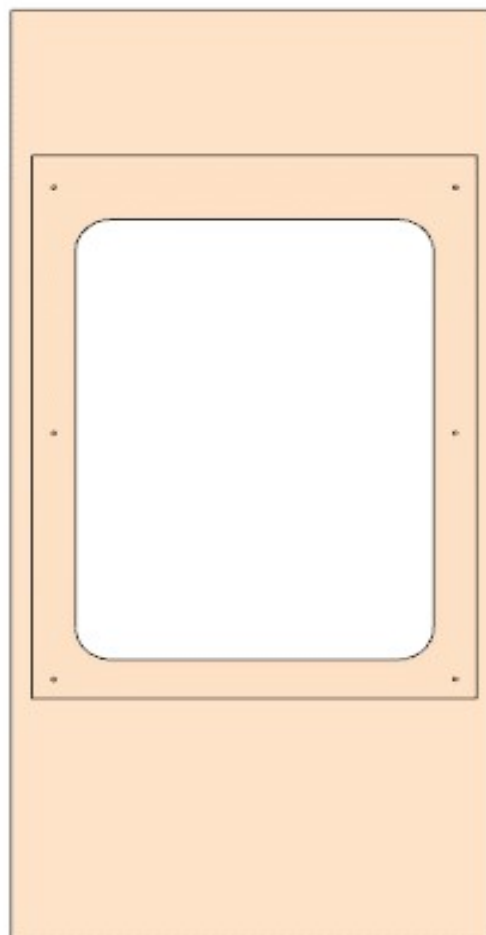

consonni&c

AZ26M

REV. GR 9

LOCALE	CODICE	DESCRIZIONE COMPONENTE	FINITURA	Q.TA	OPERATORE
BAGNO OSPITI DX	AZ26M-MG_YF01\ZF02	RIVESTIMENTI ZONA LAVELLO			Damiano

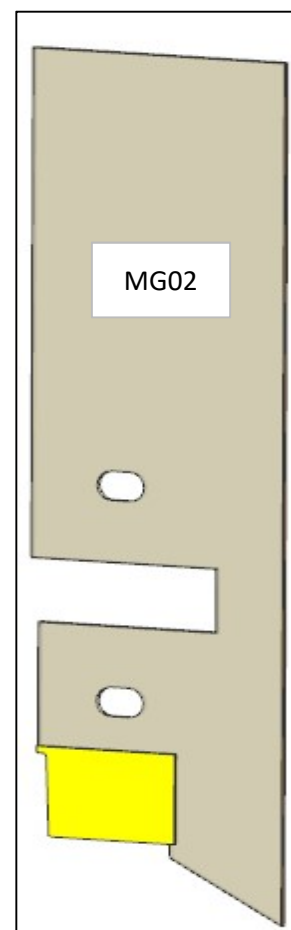
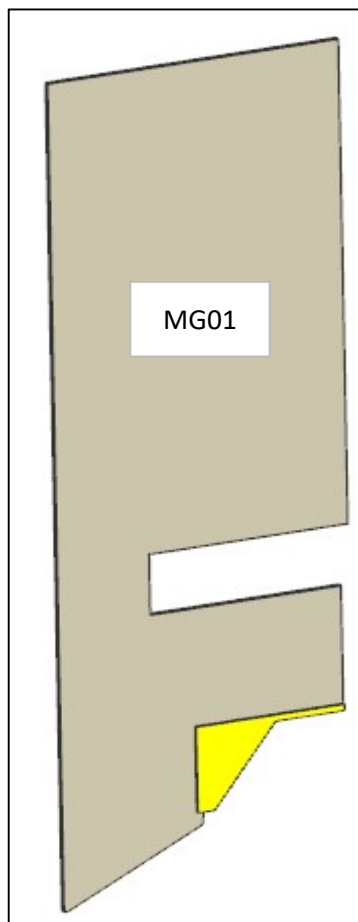

AZ26M

REV. 01-2023

REV. GR 9

LOCALE	CODICE	DESCRIZIONE COMPONENTE	FINITURA	Q.TA	OPERATORE
BAGNO OSPITI SX	AZ26M-R01_YF01	RIVESTIMENTI ZONA LEVELLO	LASTRA CHIARA	12	Damiano

ELIMINATI PZ. 5 e 13
AGGIUNTI MG ZF01
MG ZF02

ELEMENTO DA MONTARE con:
R01_YF01_01/02
RI01_YF01_05/12
 e spedire con un unico imballo

- 1 - L.646 x H.2028 x sp 11
- 2 - L.330 x H.210 x sp 6
- 3 - 10 - L.76 x H.1180 x 71
- 4 - 11 - L.76 x H.288 x 71
- 5 - L. 330 x H.210 x sp 6
- 6 - L.572 x H.237 x sp 16
- 7 - L 572 x H.200 x sp 16
- 8 - L.571 x H.288 x sp 16
- 9 - L.714 x H.79 x sp 16
- 12 - L.602 x H.2009 x sp 11

FERRAMENTA:
 N° 4 - FITLOCK MASCHIO

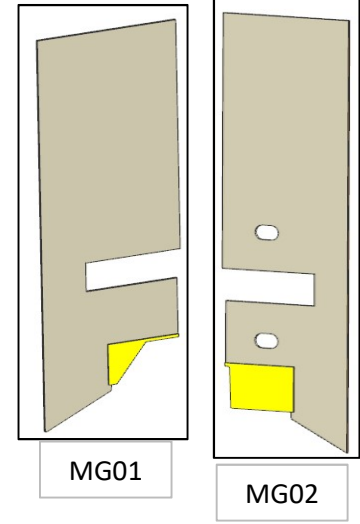
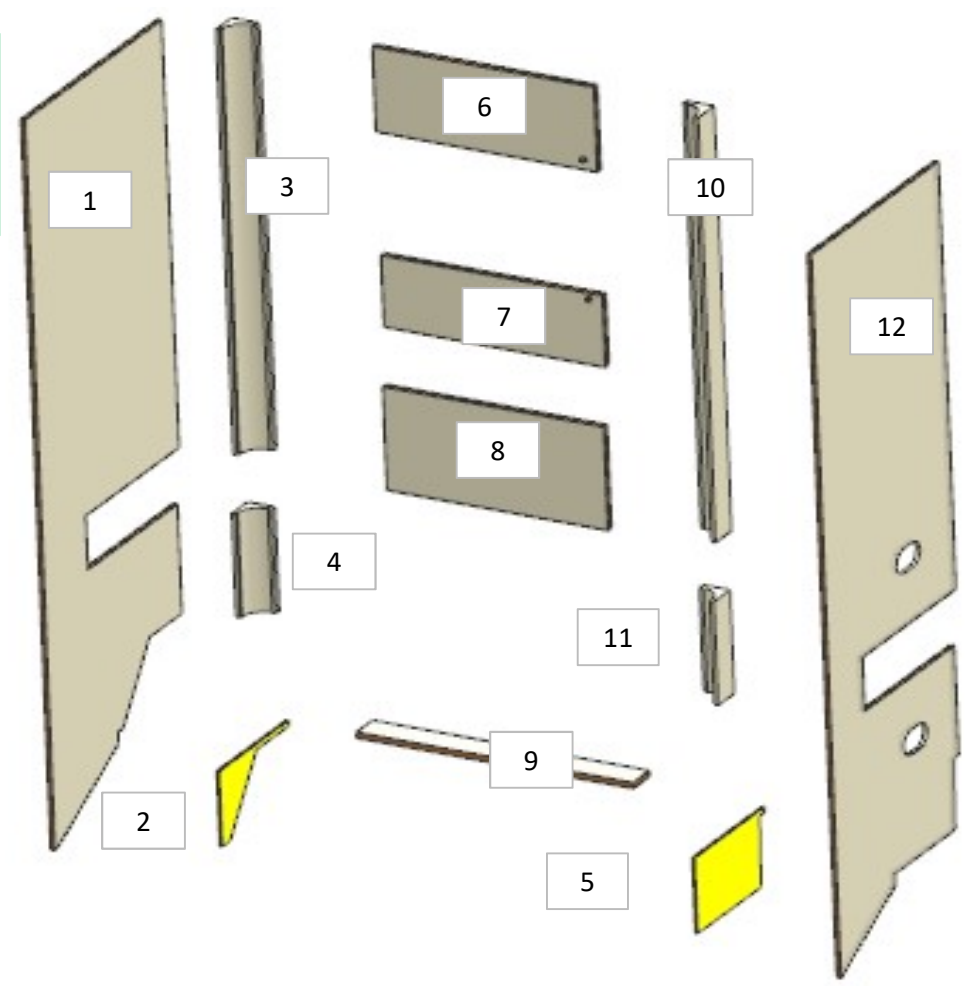

AZ26M

REV. GR 9

LOCALE	CODICE	DESCRIZIONE COMPONENTE	FINITURA	Q.TA	OPERATORE
BAGNO OSPITI SX	AZ26M-L01_YF01	RIVESTIMENTI ZONA LAVELLO	LACCATO BIANCO RAL 9010	7	Damiano

- 1 - L. 510 x H 94 x sp 10
- 2 - L. 510 x H 37 x sp 10
- 3 - L. 300 x H 2029 x sp 10
- 4 - 6 - L. 121 x H 2029 x 121
- 5 - L. 471 x H 2029 x sp 10
- 7 - L. 193 x H 2029 x sp 10

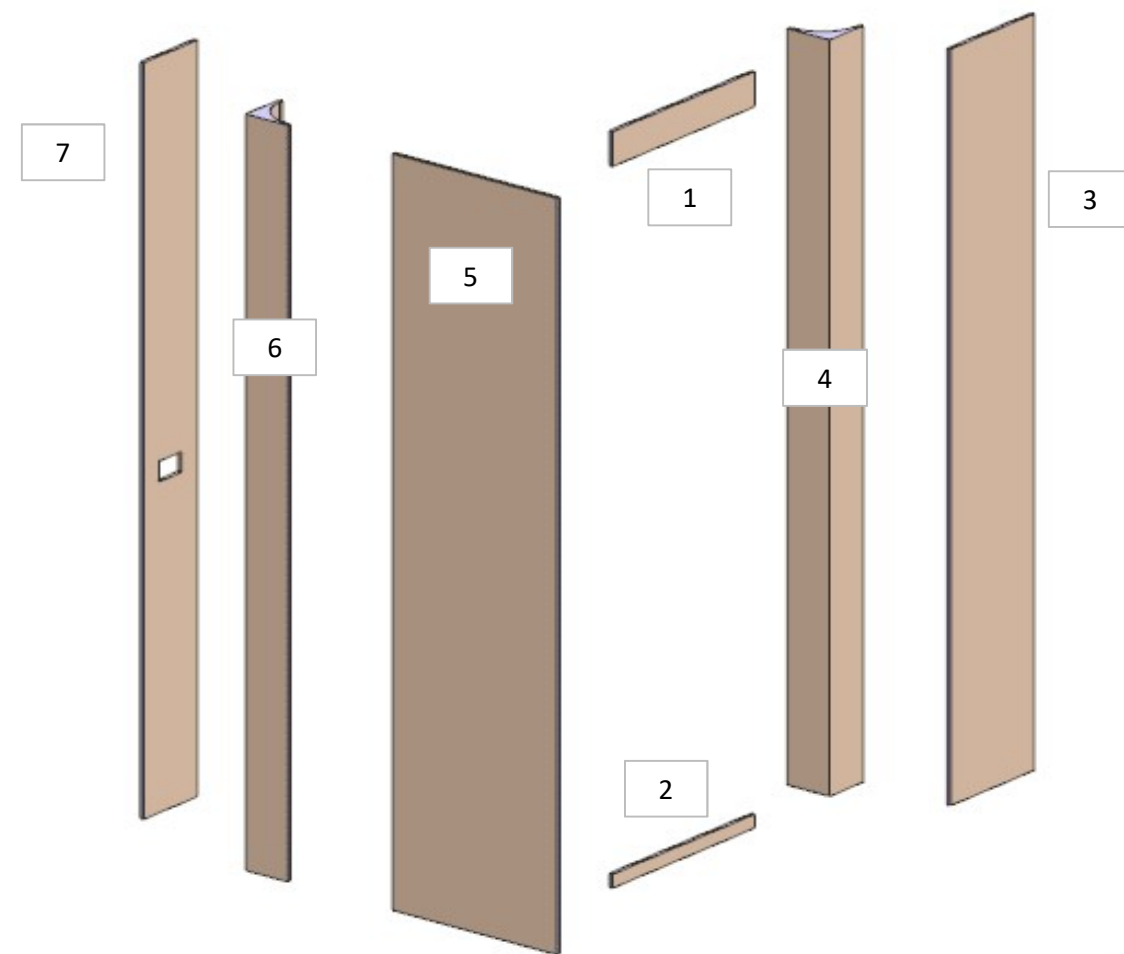

AZ26M

REV. GR 9

LOCALE	CODICE	DESCRIZIONE COMPONENTE	FINITURA	Q.TA	OPERATORE
BAGNO OSPITI SX	AZ26M-L01_YL01	RIVESTIMENTI ZONA DOCCIA	LACCATO BIANCO RAL 9010	8	Damiano

- 1 - L.924 x H.2033 x sp 10
- 2 - L.549 x H.2033 x sp 10
- 3 - L.51 x H.2033 x 51
- 4 - L.601 x H.1947 x sp 10
- 5 - L.51 x H.2033 x 42
- 6 - L.510 x H.94 x sp 10
- 7 - L.510 x H.41 x sp 10
- 8 - L.972 x H.2033 x sp 10

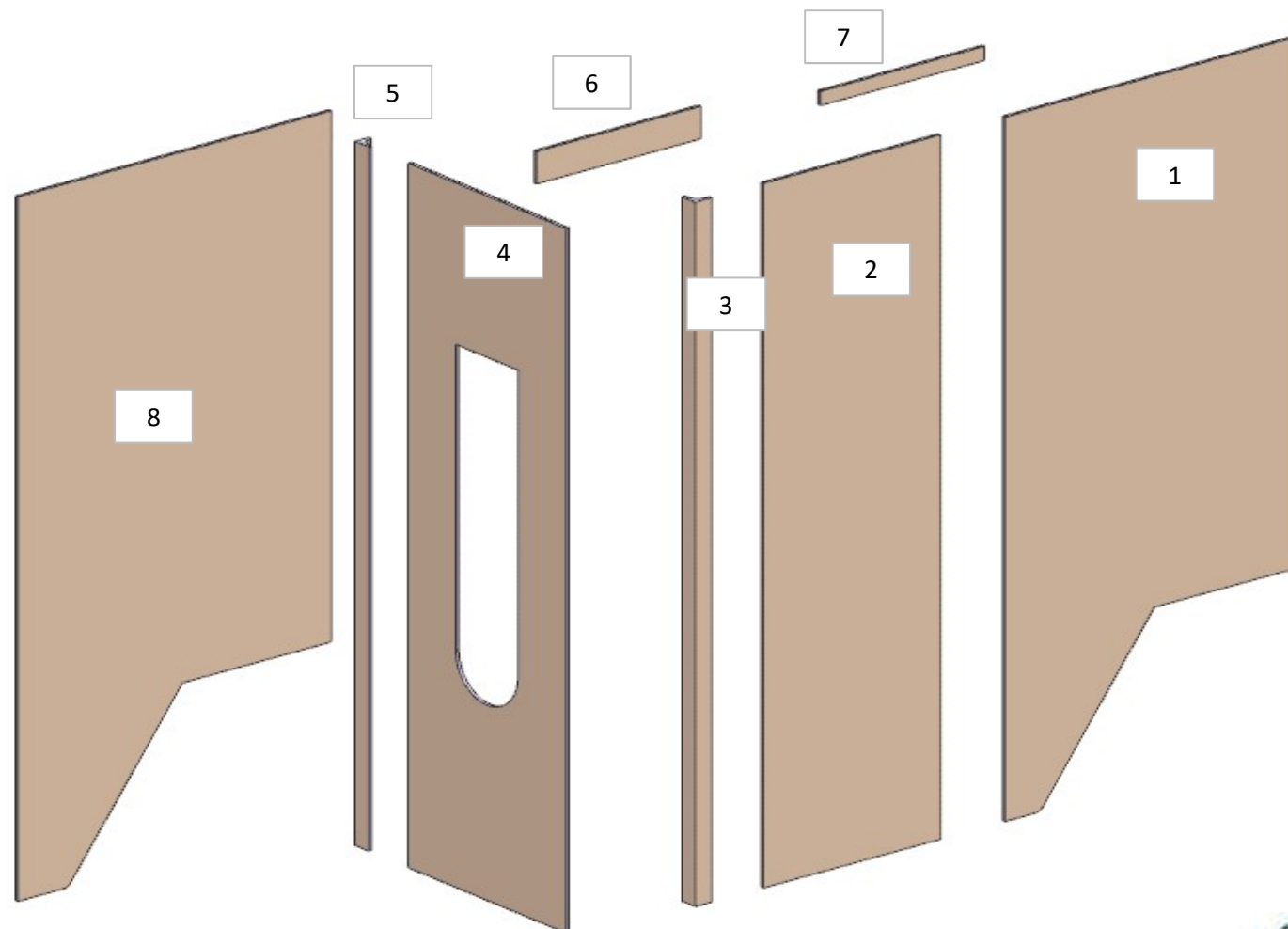

AZ26M

MOD DA GR9

REV. GR 9

LOCALE	CODICE	DESCRIZIONE COMPONENTE	FINITURA	Q.TA	OPERATORE
BAGNO OSPITI SX	AZ26M-L01_YM01	RIV SOTTO SEDUTA DOCCIA	LACCATO BIANCO RAL 9010	4	Damiano

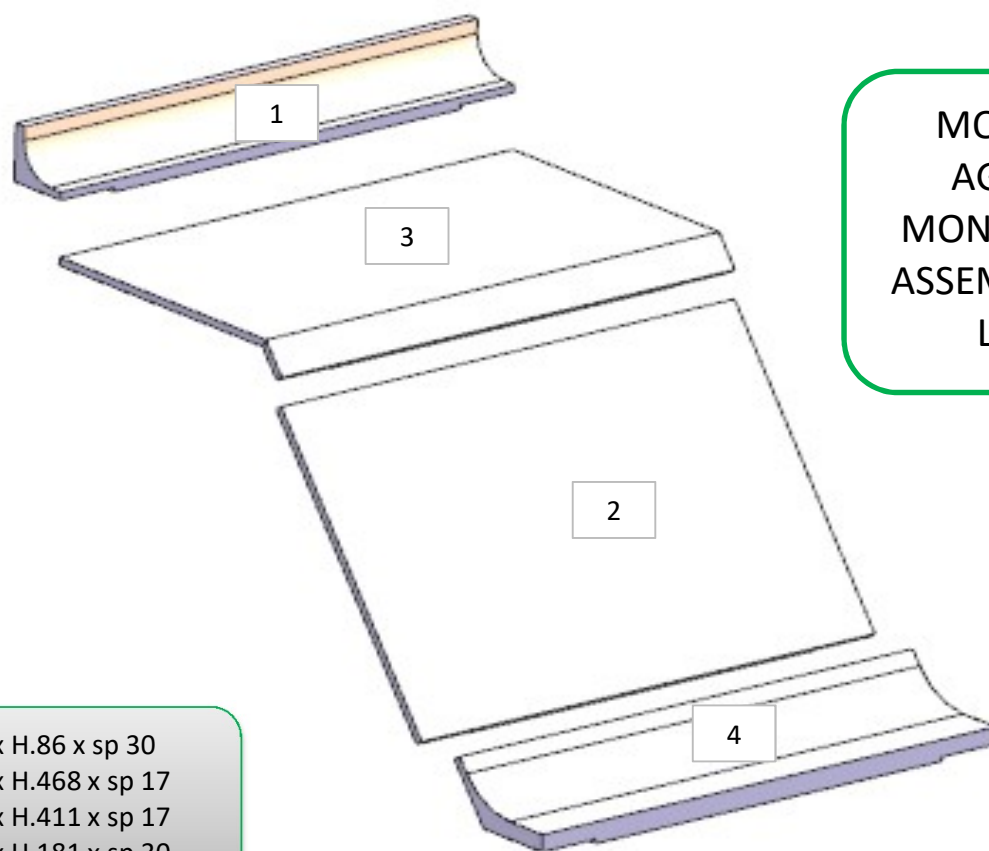

- 1 - L.683 x H.86 x sp 30
- 2 - L.683 x H.468 x sp 17
- 3 - L.683 x H.411 x sp 17
- 4 - L.683 x H.181 x sp 30

MOD AZ 227 GR9
AGGIUNTI DUE
MONTATI GREZZI DA
ASSEMBLARE DIPO LA
LACCATURA

ELEMENTO DA
MONTARE:
MG_YM01
e spedire con un
unico imballo

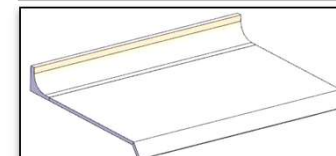

ELEMENTO DA
MONTARE:
MG_YM02
e spedire con un unico

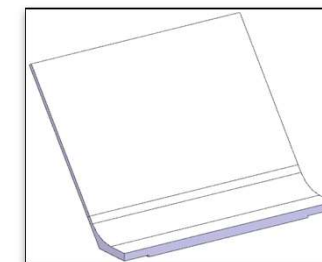

consonni&c

AZ26M

REV. GR 9

LOCALE	CODICE	DESCRIZIONE COMPONENTE	FINITURA	Q.TA	OPERATORE
BAGNO OSPITI SX	AZ26M-L01_YN01	RIV. OBLO' MURATA	LACCATO BIANCO RAL 9010	1	Damiano

1 - L 683 x H.1452 x sp 16

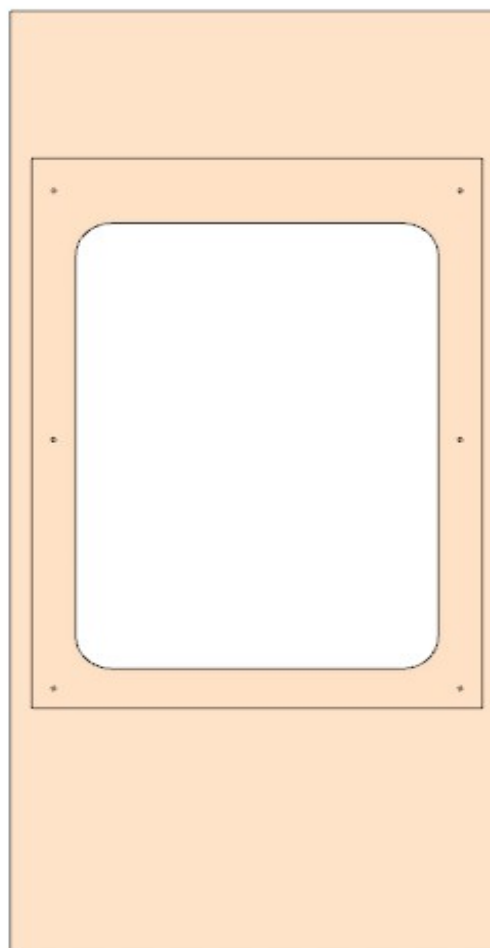

consonni&c

AZ26M

MOD DA GR9

REV. GR 9

LOCALE	CODICE	DESCRIZIONE COMPONENTE	FINITURA	Q.TA	OPERATORE
LOBBY	AZ26M-R01_CC01	RIV. LASTRA INGRESSO CABINA OSPITI DX	LASTRA CHIARA	3	Damiano

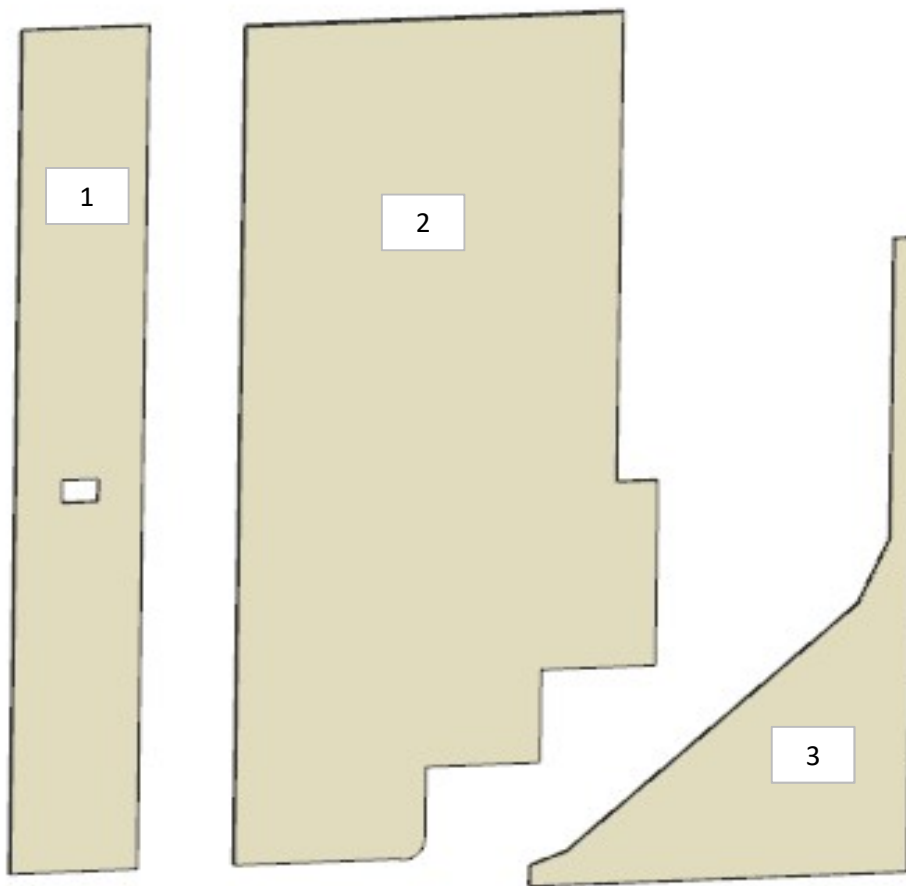

- 1 - L. 279 x H 2014 x sp 11
- 2 - L 828 x H 2025 x sp 11
- 3 - L. 828 x H 1526 x sp 11

MOD AZ 216
ALLUNGATO RIVESTIMENTO
VESRO PAVIMENTO E
RIMOSI TUTTI I LAMINATI
NERI

AZ26M

MOD DA GR7

REV. GR 9

LOCALE	CODICE	DESCRIZIONE COMPONENTE	FINITURA	Q.TA	OPERATORE
LOBBY	AZ26M-R01_CD01	RIV. LASTRA TRAVERSONAVE DISCESA SCALE POPPA	LASTRA CHIARA	2	Damiano

1 - L 2332 x H 1252 x sp 11
2 - L 817 x H 1134 x sp 11

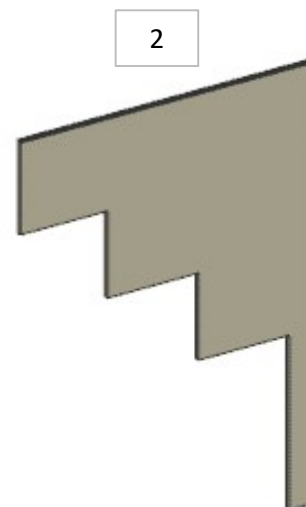
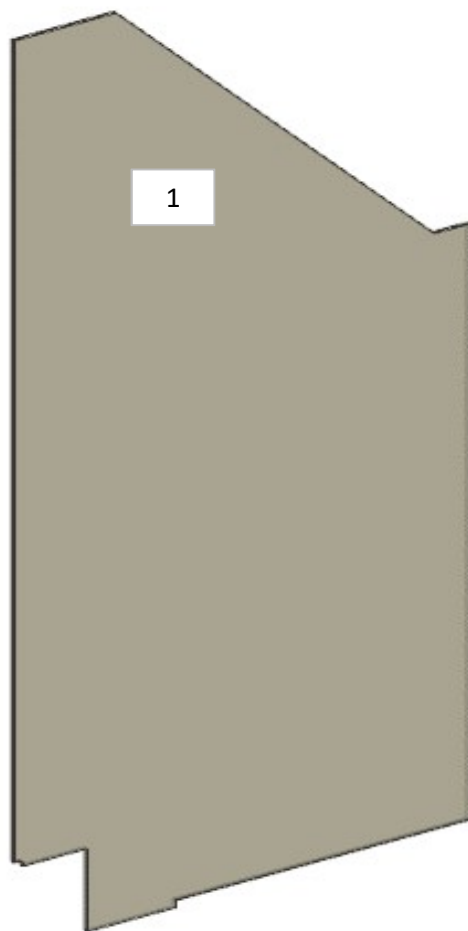

MOD. INT. 04

ELIMINATO SQUARCIO A 45°
E MODIFICATE DIMENSIONI

consonni&c

AZ26M

REV. GR 9

LOCALE	CODICE	DESCRIZIONE COMPONENTE	FINITURA	Q.TA	OPERATORE
LOBBY	AZ26M-CE01	RIVESTIMENTI LASTRA POPPA SX	OKOUME' GREZZO	1	Dante

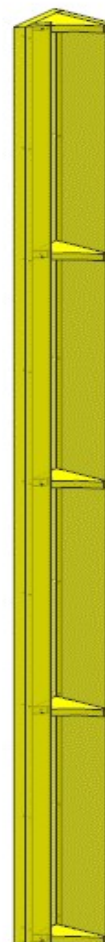

AZ26M

MOD DA GR9

REV. GR 9

LOCALE	CODICE	DESCRIZIONE COMPONENTE	FINITURA	Q.TA	OPERATORE
LOBBY	AZ26M-MF_CE01	RIVESTIMENTI LASTRA POPPA SX			Damiano

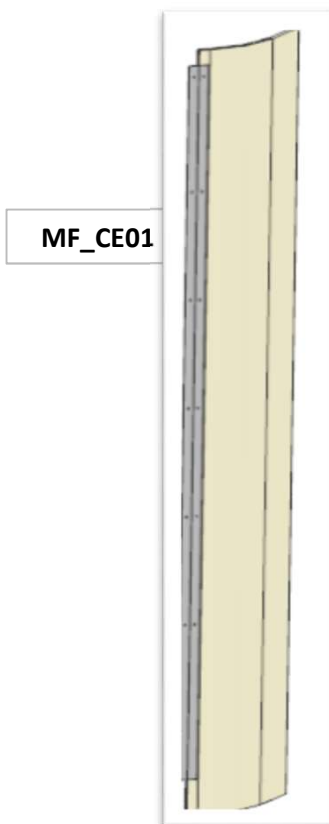

AZ26M

MOD DA GR9

REV. GR 9

LOCALE	CODICE	DESCRIZIONE COMPONENTE	FINITURA	Q.TA	OPERATORE
LOBBY	AZ26M-R01_CE01	RIVESTIMENTI LASTRA POPPA SX	LASTRA CHIARA	5	Damiano

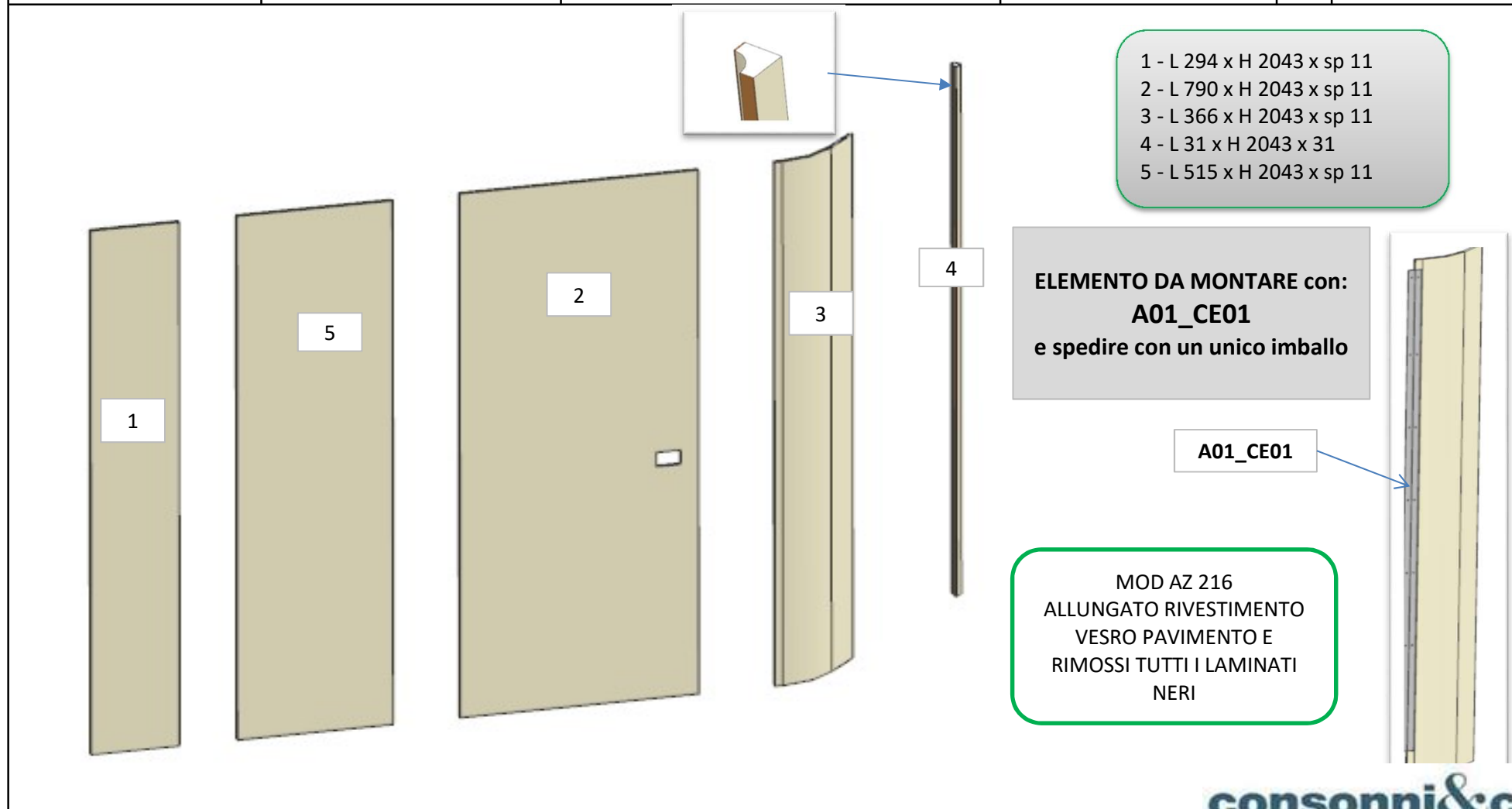

AZ26M

MOD DA GR9

REV. GR 9

LOCALE	CODICE	DESCRIZIONE COMPONENTE	FINITURA	Q.TA	OPERATORE
LOBBY	AZ26M-A01_CE01	RIVESTIMENTI LASTRA POPPA SX	ALLUMINIO	1	Damiano



MOD AZ 216
ALLUNGATO RIVESTIMENTO
VESRO PAVIMENTO E
RIMOSI TUTTI I LAMINATI
NERI

ELEMENTO DA MONTARE con:
R01_CE01
e spedire con un unico imballo

R01_CE01

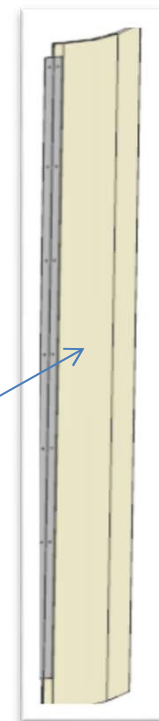

1 - L.50 x H 1904 x sp 2

consonni&c

AZ26M

MOD DA GR9

REV. GR 9

LOCALE	CODICE	DESCRIZIONE COMPONENTE	FINITURA	Q.TA	OPERATORE
LOBBY	AZ26M-L01_CF01	RIVESTIMENTI LACCATI PRUA SX	LACCATO BIANCO RAL 9010	7	Damiano

- 1 - L 833 x H 3055 x sp 10
- 2 - L 59 x H 484 x sp 10
- 3 - L 517 x H 922 x sp 10
- 4 - L 160 x H 922 x 160
- 5 - L 160 x H 1399 x 160
- 6 - L 160 x H 290 x 160
- 7 - L 517 x H 736 x sp 10

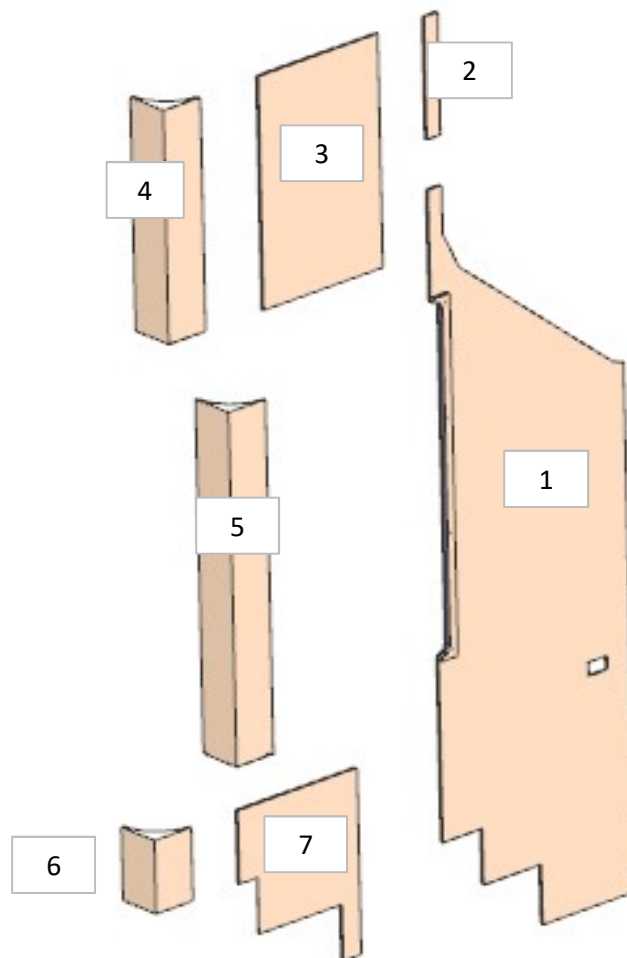

MOD AZ 216
ALLUNGATO RIVESTIMENTO
VESRO PAVIMENTO E
RIMOSI TUTTI I LAMINATI
NERI

AZ26M

REV. 01-2023

REV. GR 9

LOCALE	CODICE	DESCRIZIONE COMPONENTE	FINITURA	Q.TA	OPERATORE
LOBBY	AZ26M-MF_CH01	MOBILE QUADRO ELETTRICO			Damiano

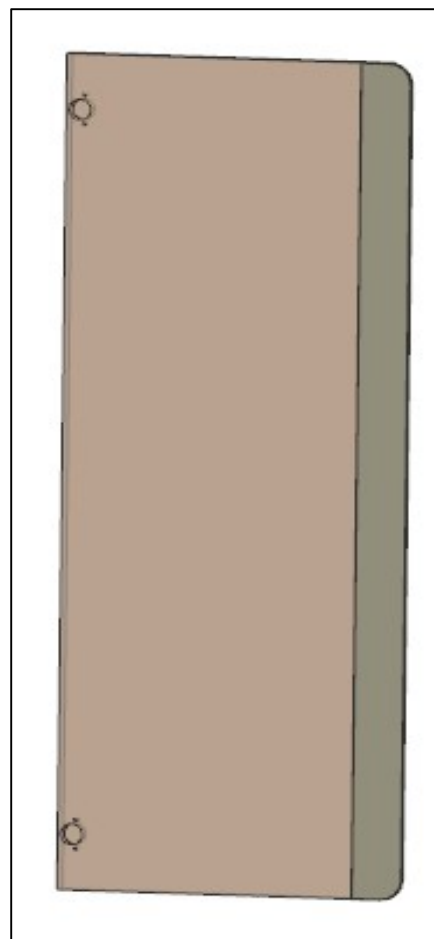

FERRAMENTA:

- N° 2 - CERNIERA PIANA
- N° 2 - BASETTA H6
- N° 8 - ANKOR BORGHI
- N° 8 - VITI 4 MA X 8 PER ANKOR BORGHI

AZ26M

REV. 01-2023

REV. GR 9

LOCALE	CODICE	DESCRIZIONE COMPONENTE	FINITURA	Q.TA	OPERATORE
LOBBY	AZ26M-R01_CH01	MOBILE QUADRO ELETTRICO	LASTRA CHIARA	1	Damiano

1 - L.80 x H 1392 x sp 6

ELEMENTO DA
MONTARE con:
L01_CH01
e spedire con un
unico imballo

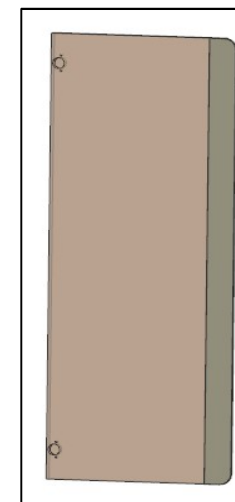
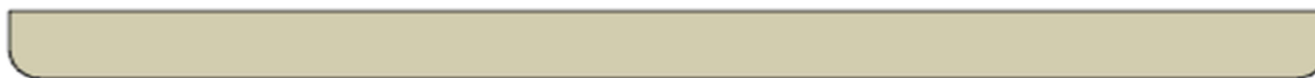

consonni&c

AZ26M

REV. 01-2023

REV. GR 9

LOCALE	CODICE	DESCRIZIONE COMPONENTE	FINITURA	Q.TA	OPERATORE
LOBBY	AZ26M-L01_CH01	MOBILE QUADRO ELETTRICO	LACCATO BIANCO RAL 9010	1	Damiano

1 - L.515 x H 1391 x sp 25

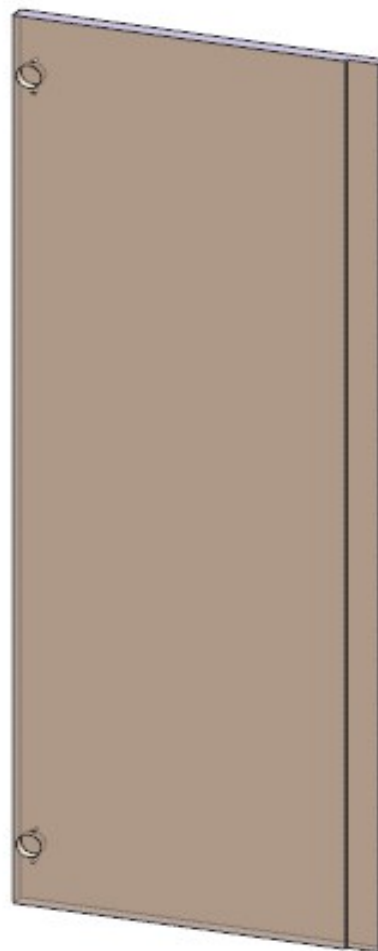

**ELEMENTO DA
MONTARE con:
R01_CH01
e spedire con un
unico imballo**

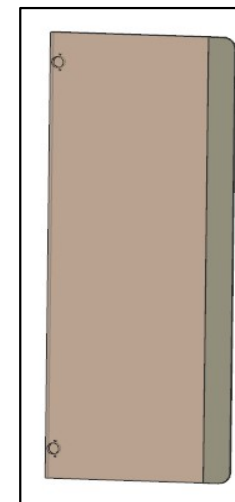

consonni&c