

LOCALE	CODICE	DESCRIZIONE COMPONENTE	FINITURA	Q.TA
CABINA ARMATORE	MD299_MF_AA01	ARMADIO SX PRUA		1

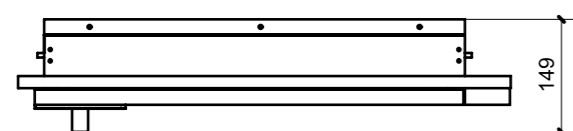
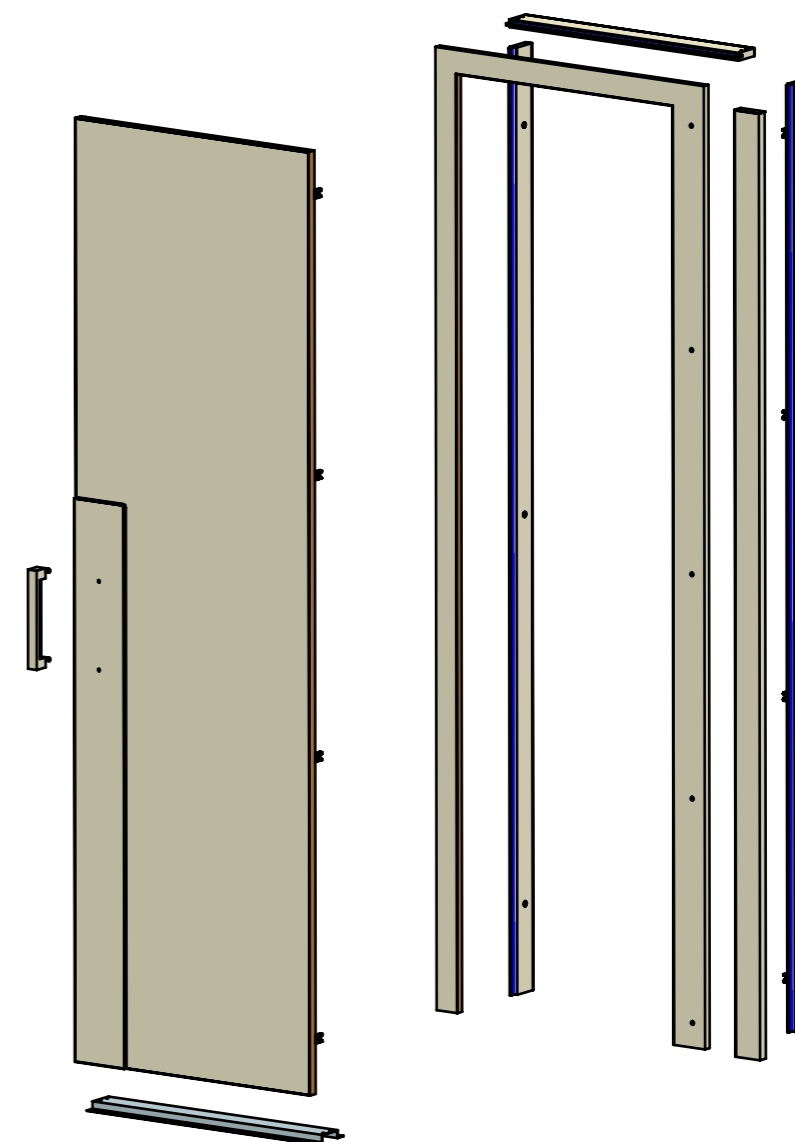
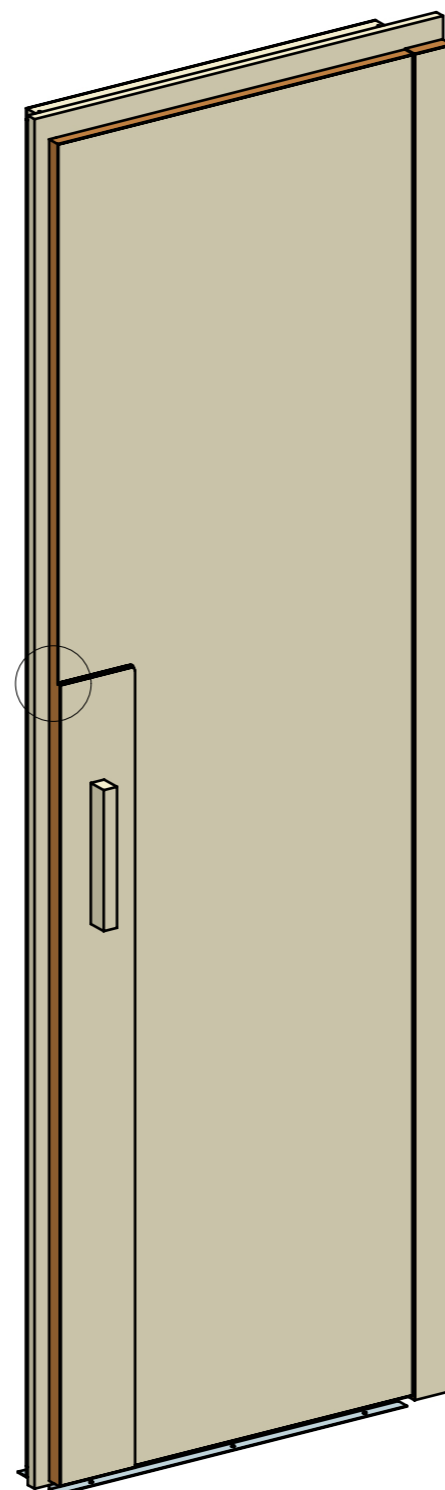
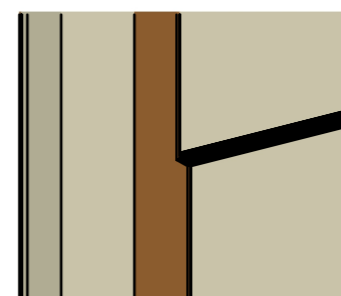
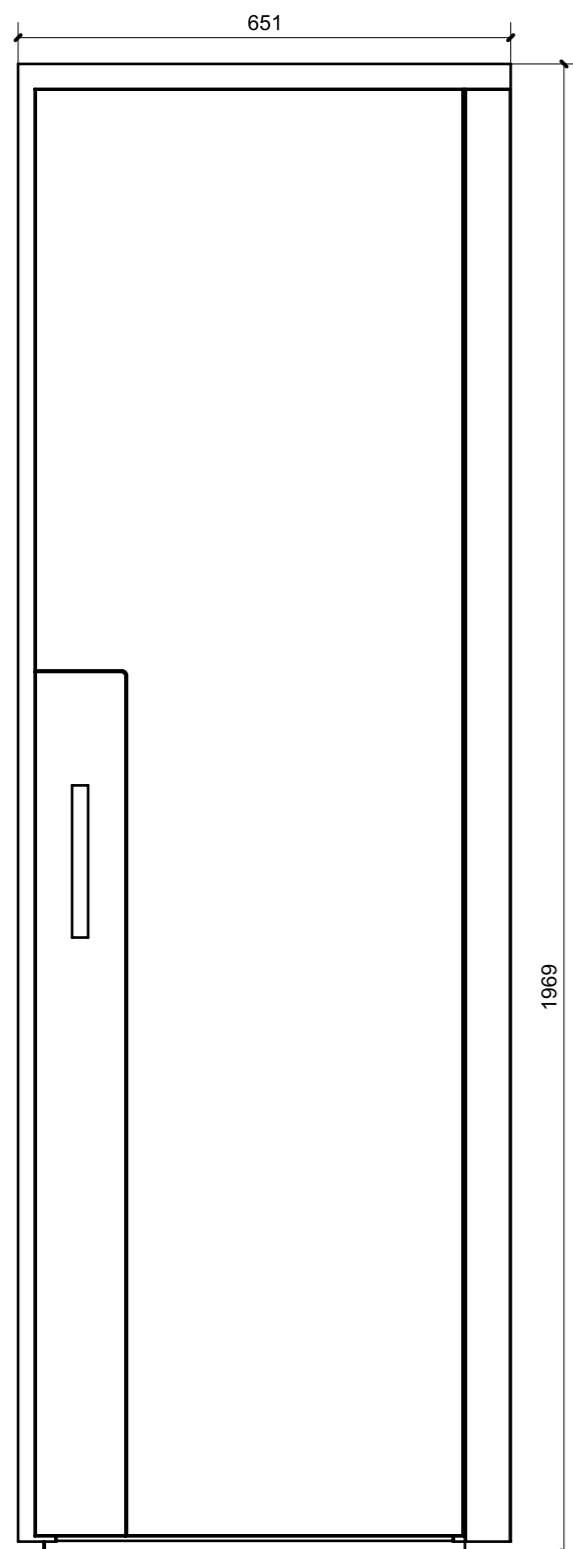

FERRAMENTA	QTY
BASE_6_HAFELE_329_84_026	4
BUSSOLA 4MA X 10 FORO DIAM.6	2
BUSSOLA 5MA ANKOR BORGHI X CERNIERA PIANA	16
CALAMITA SEALED MAGNETIC_TECNOPARTNER_MC-JM50-BL	2
CERNIERA 94° PIANA AMMORTIZZATA_HAFELE_329_49_310	4
GOMMINO PARACOLPO ANTA	2
PLACCHETTA COUNTER STEEL_TECNOPARTNER_MC-JM49	2
VITE 4MA X 30 TESTA SVASATA ESAGONALE NERA	2
VITE 4MAX8 ANKOR BORGHI X CERNIERA PIANA	16
VITE 6MA X 25 TESTA SVASATA	6

VERNICIATURA LASTRA/LACCATI:

● = VERNICIARE 1 LATO + FILI RASATI O BORDATI

NESSUN SIMBOLO = VERNICIARE 2 LATI + FILI RASATI O BORDATI

LOCALE	CODICE	DESCRIZIONE COMPONENTE	FINITURA	Q.TA
CABINA ARMATORE	MD299_R01_AA01	ARMADIO SX PRUA	LASTRA SCURA	1

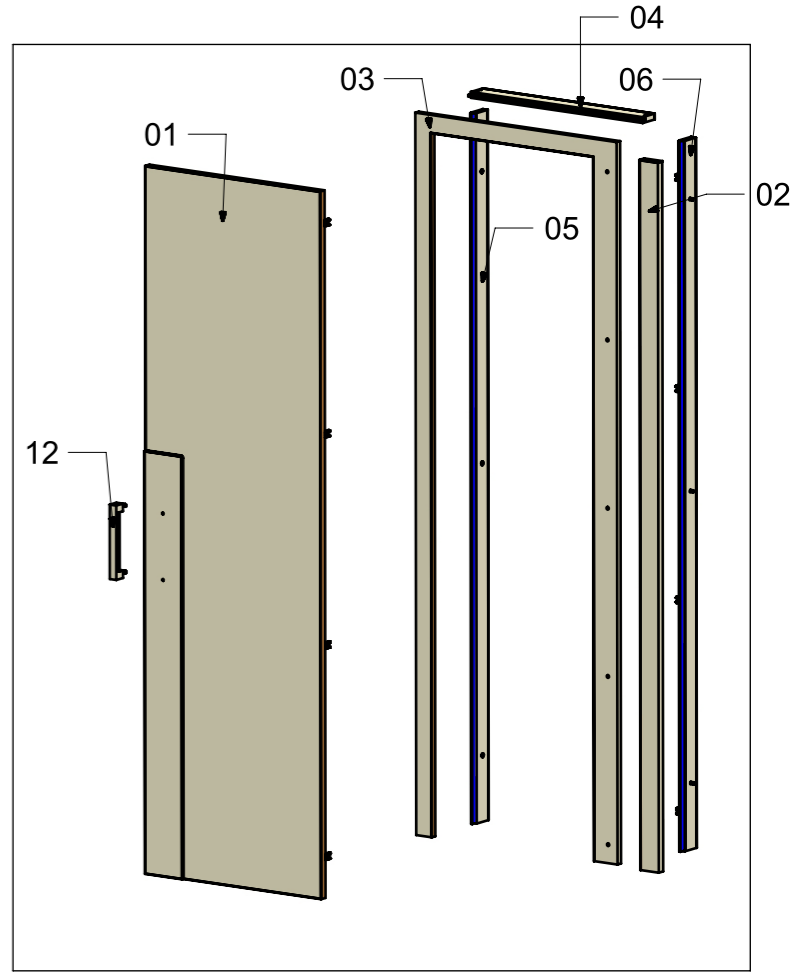
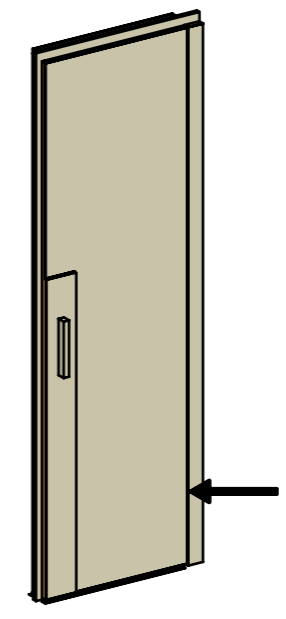
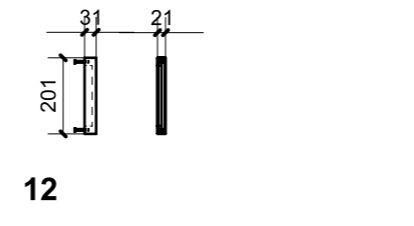
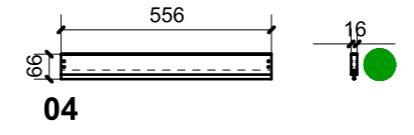
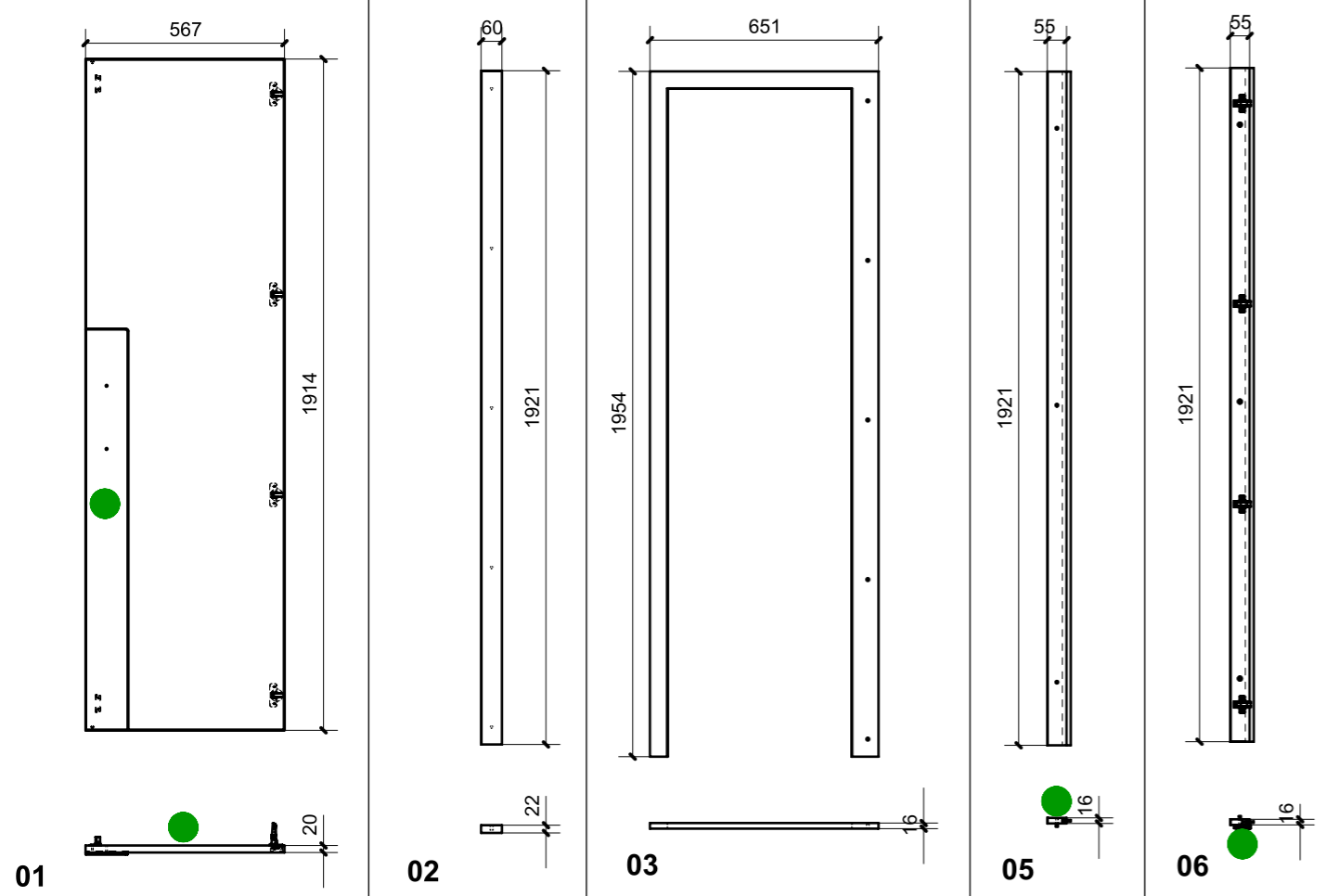

ELEMENTI DA MONTARE CON A01  
IN MF\_AA01  
e spedire con unico imballo

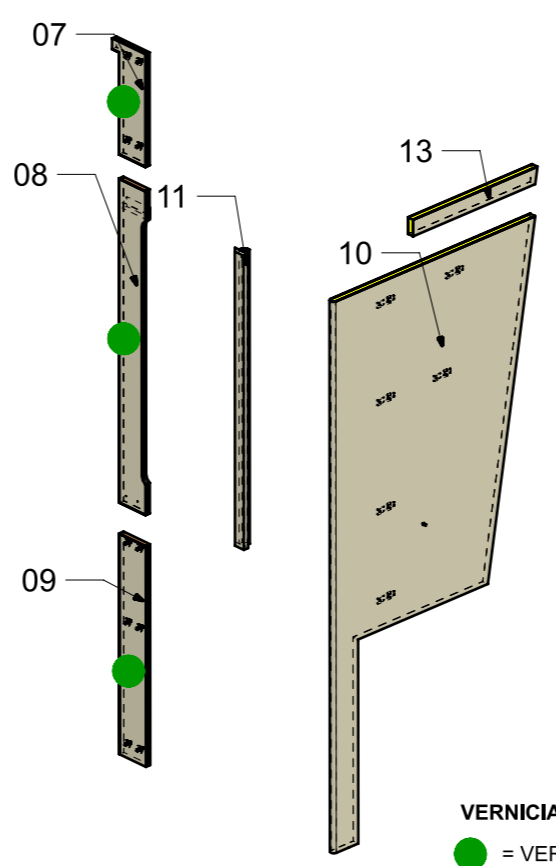
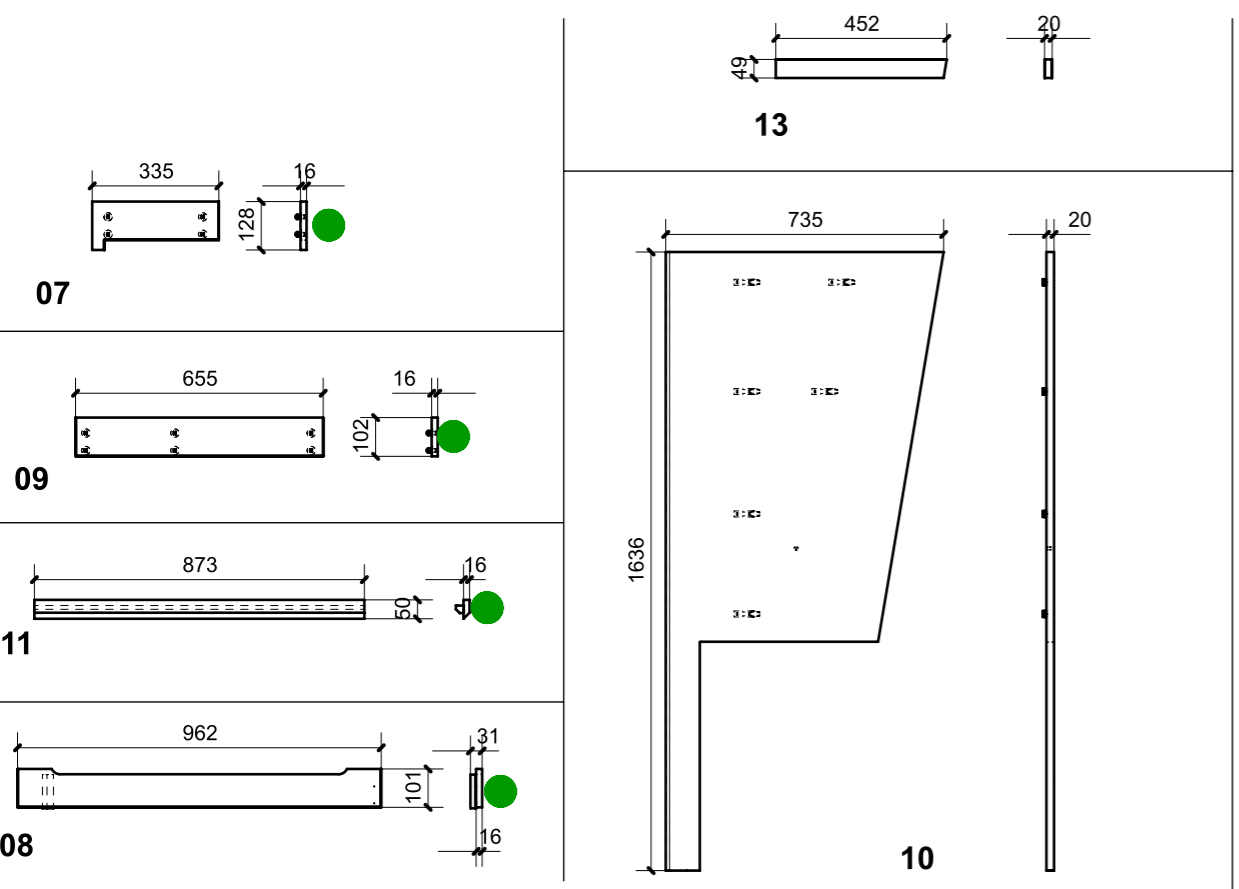

FERRAMENTA	QTY
BASE_6_HAFELE_329_84_026	4
BUSSOLA 4MA X 10 FORO DIAM.6	2
BUSSOLA 5MA ANKOR BORGHI X CERNIERA PIANA	16
BUSSOLA 6MA X 10 FORO DIAM.8	1
CALAMITA SEALED MAGNETIC_TECNOPARTNER_MC-JM50-BL	2
CERNIERA 94° PIANA AMMORTIZZATA_HAFELE_329_49_310	4
GOMMINO PARACOLPO ANTA	2
MS INCASSO_ITALVIPLA_972_FMPC_M1B	10
PARTE PANNELLO CON INCASTRO_HAFELE_262_49_356	3
PARTE PANNELLO CON INCASTRO_HAFELE_262_49_356 AGG. INVERTITO	3
PLACCHETTA COUNTER STEEL_TECNOPARTNER_MC-JM49	2
VITE 4MA X 30 TESTA SVASATA ESAGONALE NERA	2
VITE 4MAX8 ANKOR BORGHI X CERNIERA PIANA	16
VITE 6MA X 25 TESTA SVASATA	6

VERNICIATURA LASTRA/LACCATI:  
● = VERNICIARE 1 LATO + FILI RASATI O BORDATI  
NESSUN SIMBOLO = VERNICIARE 2 LATI + FILI RASATI O BORDATI

LOCALE	CODICE	DESCRIZIONE COMPONENTE	FINITURA	GR
CABINA ARMATORE	MD299_R01_AB01	STRUTTURA COLONNA SX	LASTRA SCURA	9

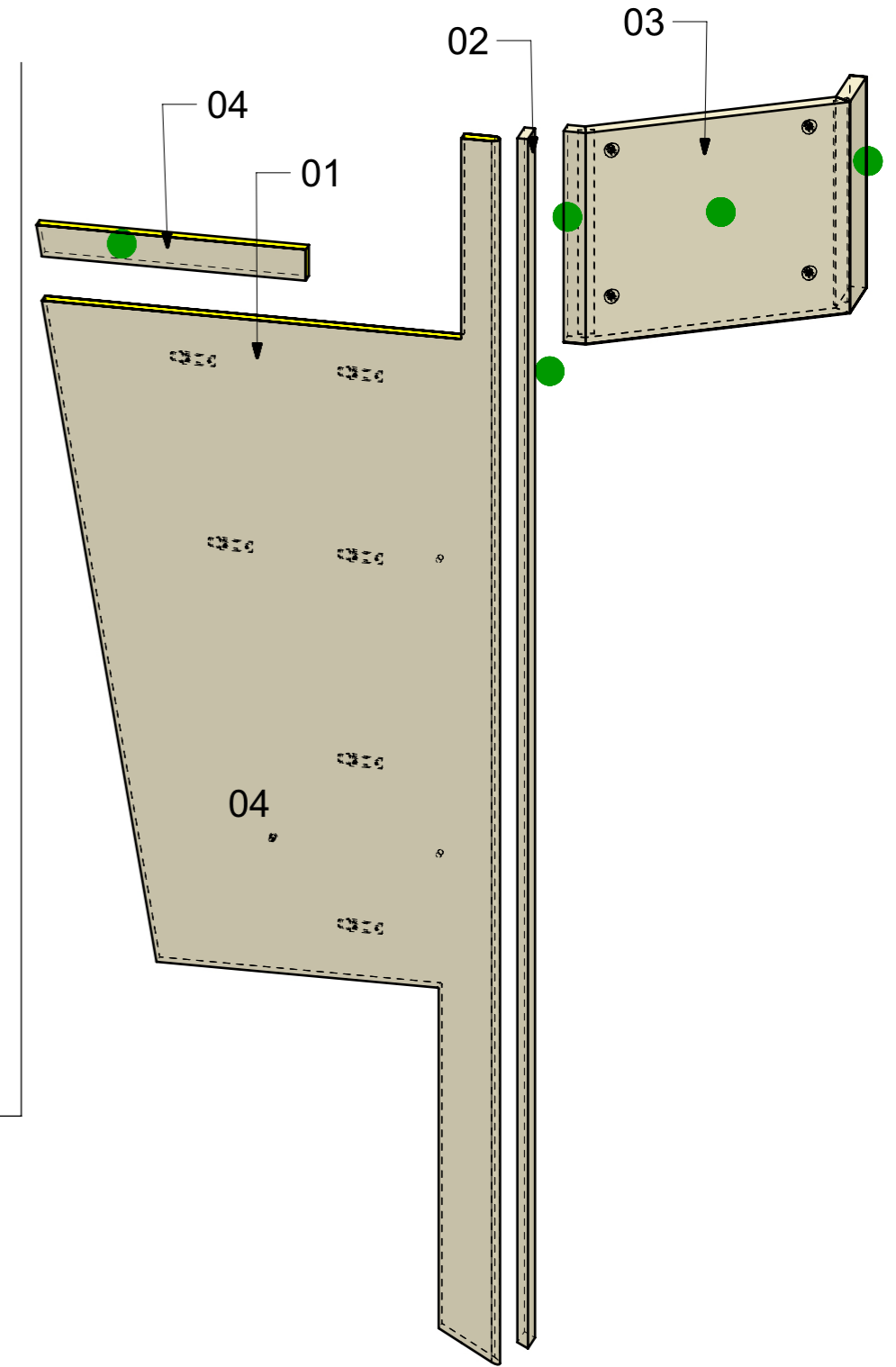
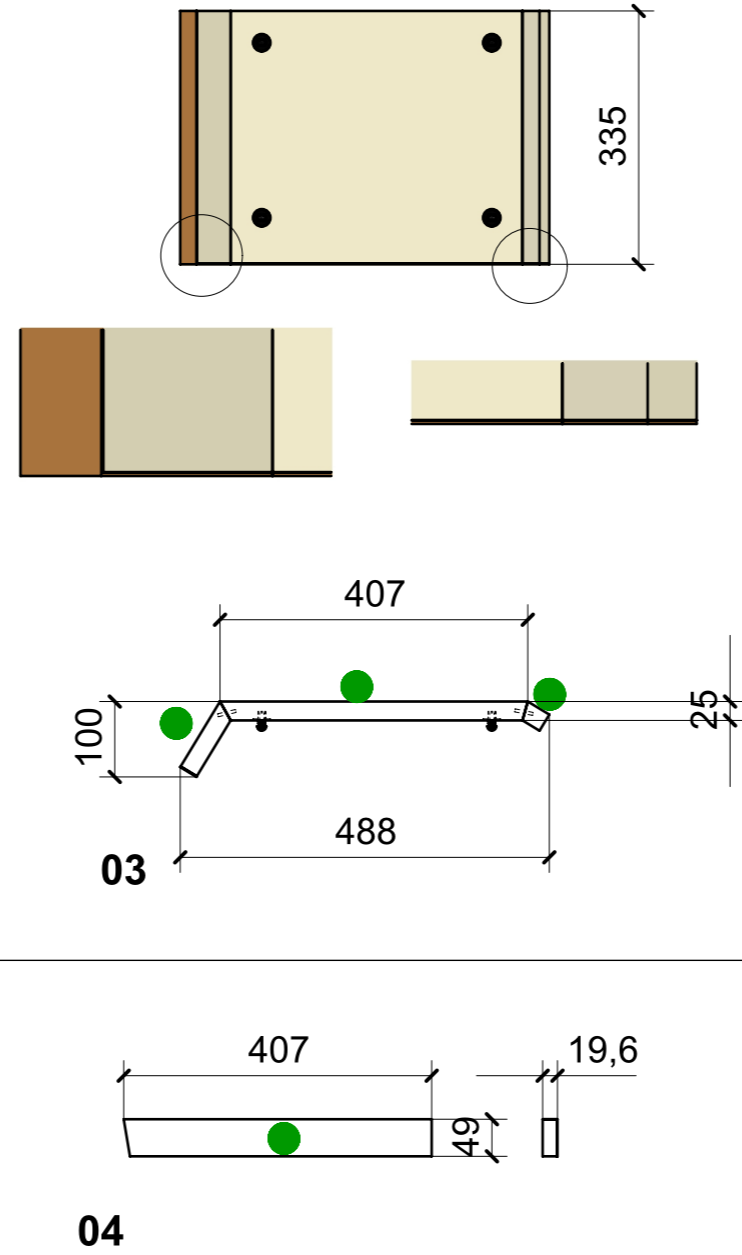
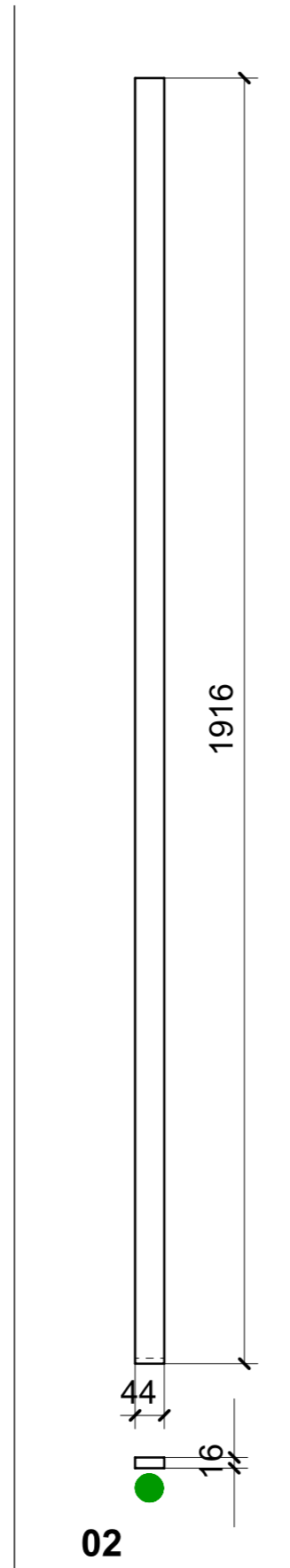
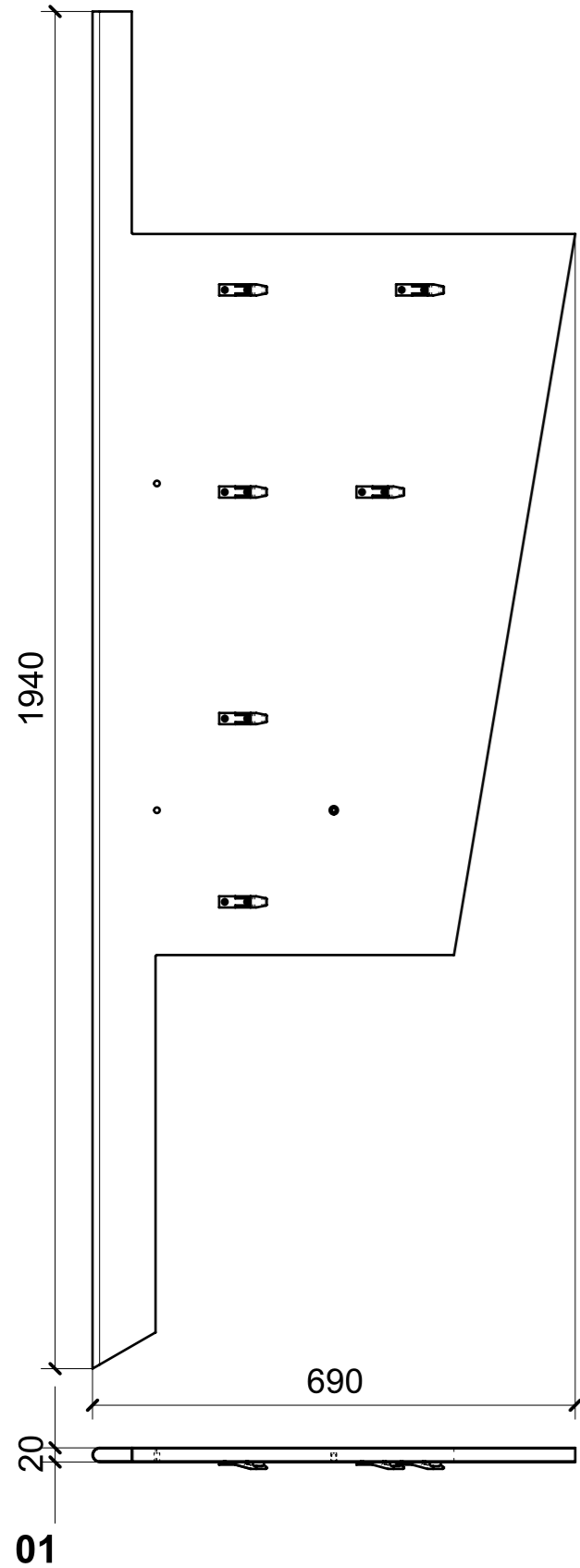

FERRAMENTA	QTY
BUSSOLA 6MA X 10 FORO DIAM.8	1
PARTE PANNELLO CON INCASTRO_HAFELE_262_49_356 OPPOSTO	3
PARTE PANNELLO CON INCASTRO_HAFELE_262_49_356 AGG. RIBALTATO	3
MS INCASSO_ITALVIPLA_972_FMPC_M1B	4

VERNICIATURA LASTRA/LACCATI:

● = VERNICIARE 1 LATO + FILI RASATI O BORDATI

NESSUN SIMBOLO = VERNICIARE 2 LATI + FILI RASATI O BORDATI

LOCALE	CODICE	DESCRIZIONE COMPONENTE	FINITURA	Q.TA
CABINA ARMATORE	MD299_L01_AC01	PONTE AC MURATA SX	LACCATO BIANCO 9010	1

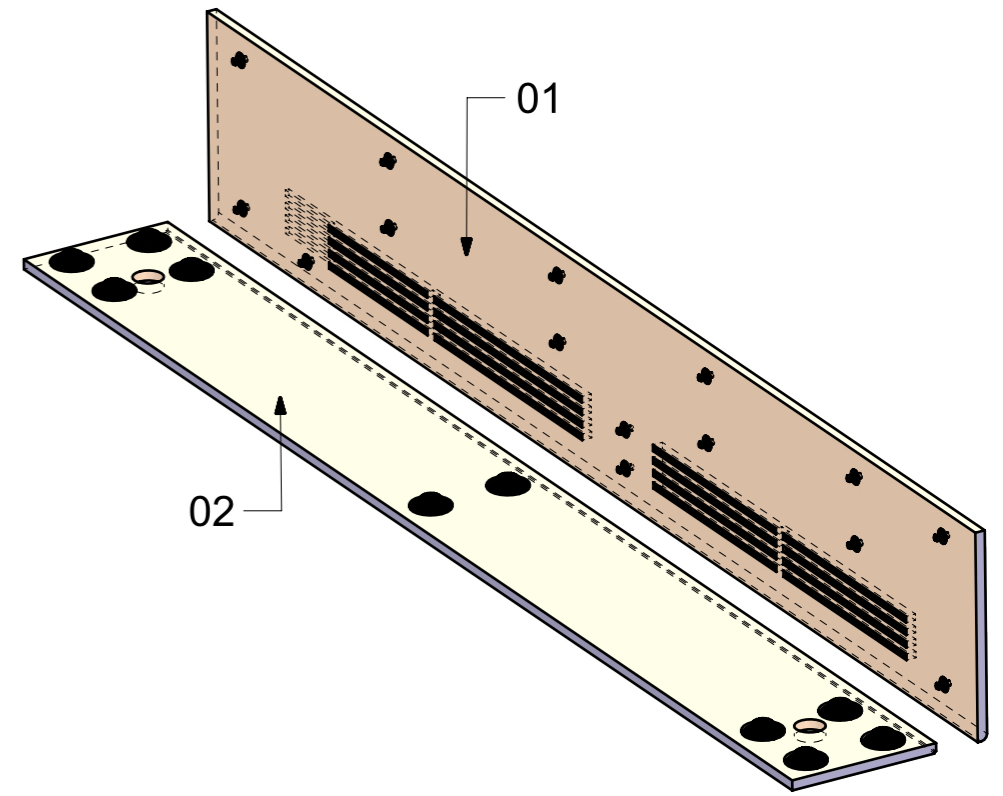
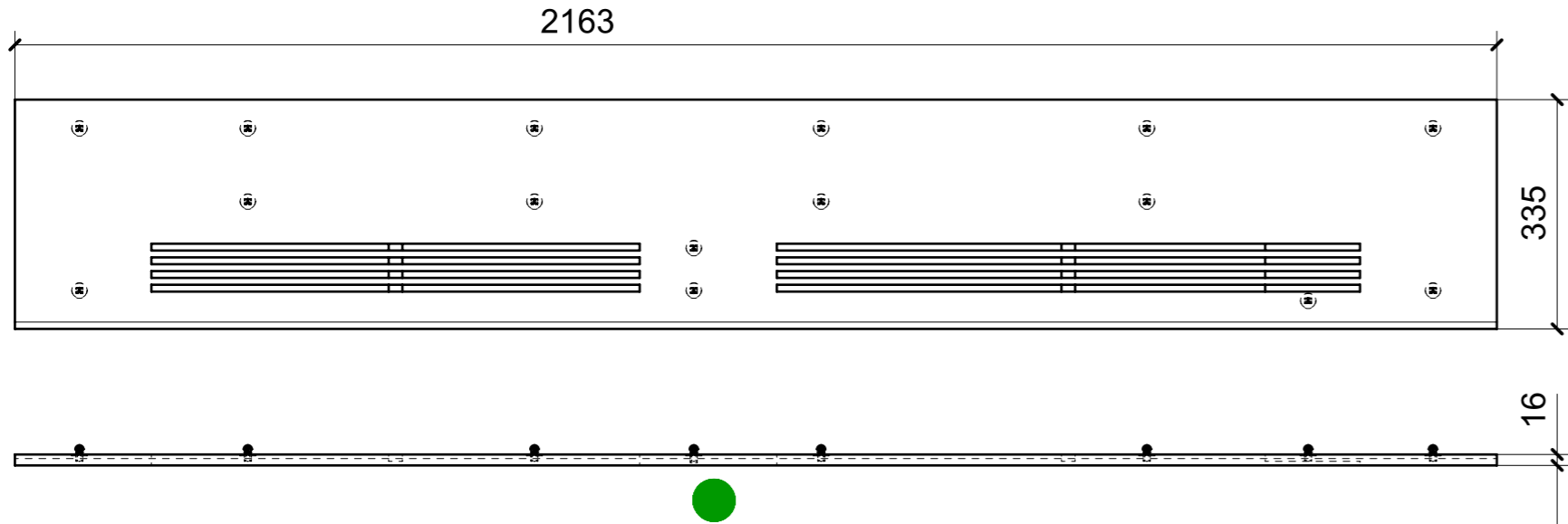

FERRAMENTA	QTY
MS INCASSO_ITALVIPLA_972_FMPC_M1B	15
FITLOCK M_MASCHERPA_3MM_6020202101	10

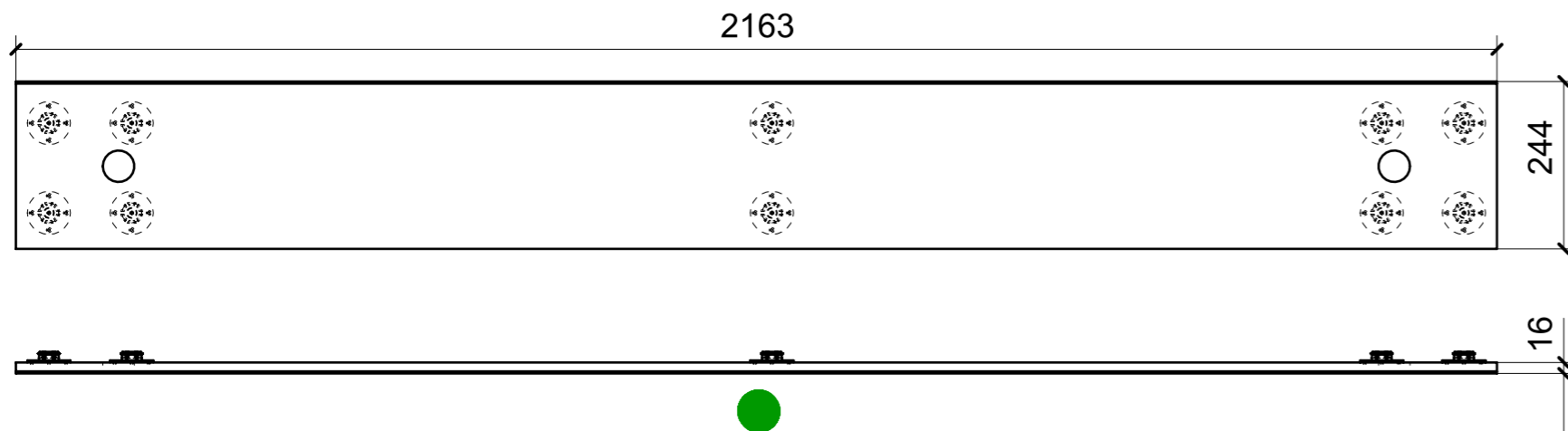

VERNICIATURA LASTRA/LACCATI:

● = VERNICIARE 1 LATO + FILI RASATI O BORDATI

NESSUN SIMBOLO = VERNICIARE 2 LATI + FILI RASATI O BORDATI

LOCALE	CODICE	DESCRIZIONE COMPONENTE	FINITURA	Q.TA
CABINA ARMATORE	MD299_R01_AAD01	TOP MOBILE CONTENITORE MURATA SX OPT	LASTRA SCURA	1

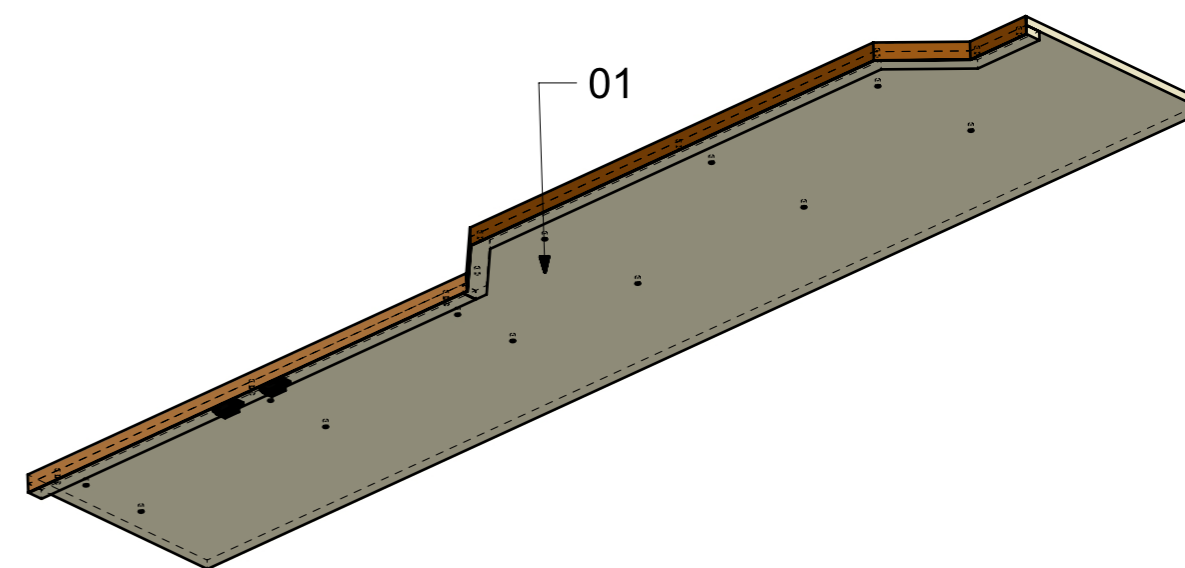
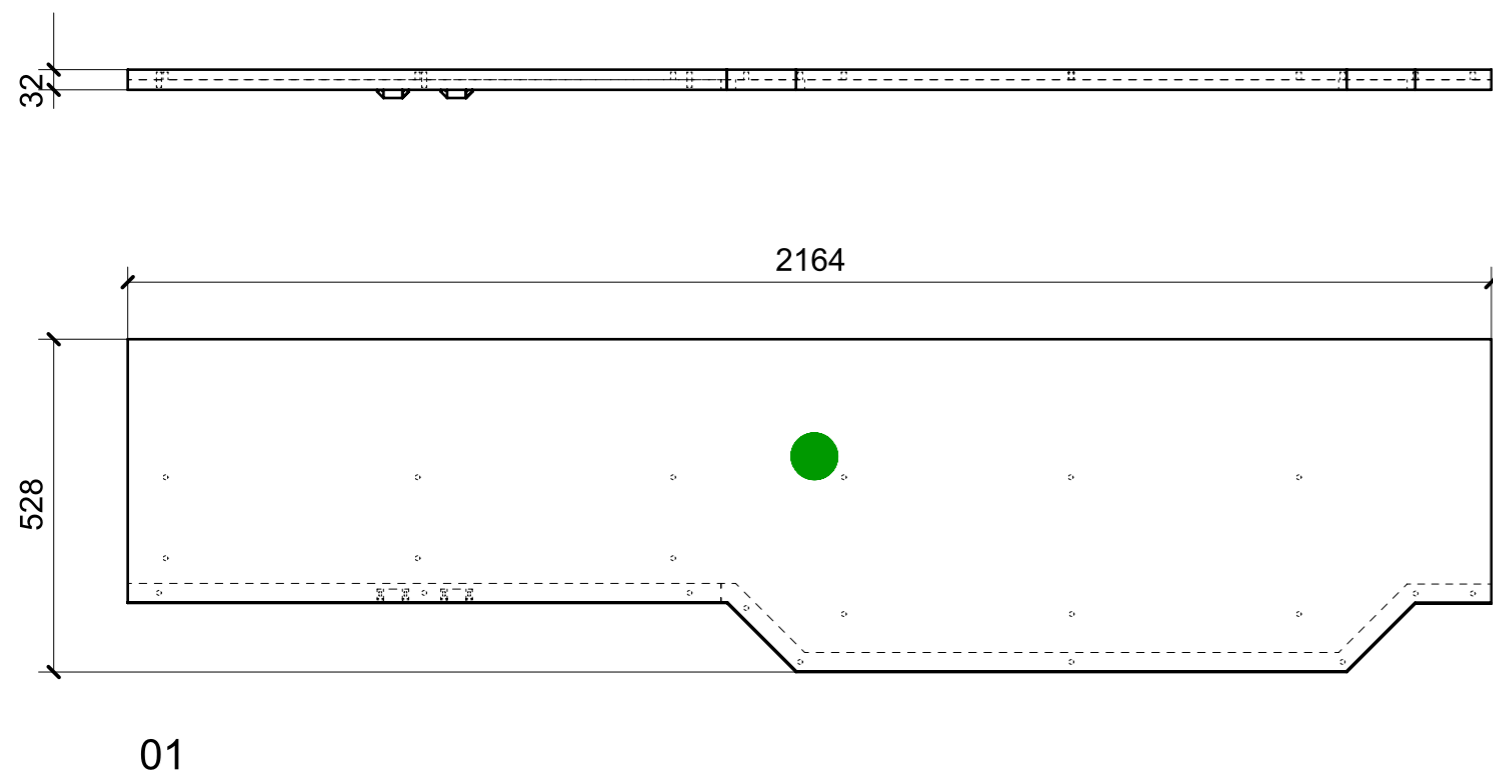

FERRAMENTA	QTY
CALAMITA SEALED MAGNETIC_TECNOPARTNER_MC-JM50-BL	2

VERNICIATURA LASTRA/LACCATI:

● = VERNICIARE 1 LATO + FILI RASATI O BORDATI

NESSUN SIMBOLO = VERNICIARE 2 LATI + FILI RASATI O BORDATI

LOCALE	CODICE	DESCRIZIONE COMPONENTE	FINITURA	Q.TA
CABINA ARMATORE	MD299_R01_AD01	MOBILE CONTENITORE MURATA SX	LASTRA SCURA	1

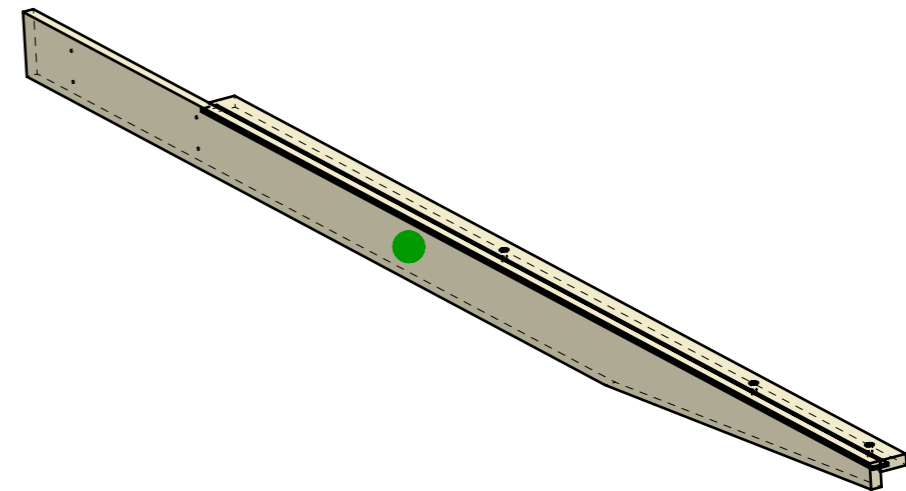
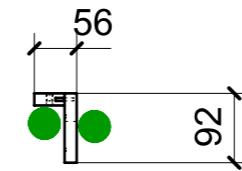
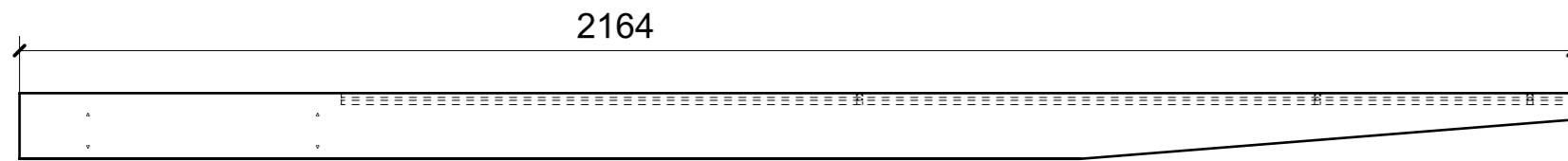

FERRAMENTA	QTY
BUSSOLA 6MA X 10 FORO DIAM.8	3

VERNICIATURA LASTRA/LACCATI:

● = VERNICIARE 1 LATO + FILI RASATI O BORDATI

NESSUN SIMBOLO = VERNICIARE 2 LATI + FILI RASATI O BORDATI

LOCALE	CODICE	DESCRIZIONE COMPONENTE	FINITURA	Q.TA
CABINA ARMATORE	MD299_MG_AE01	RIVESTIMENTO PARETE TV	LASTRA SCURA	1

**MG\_AE02**

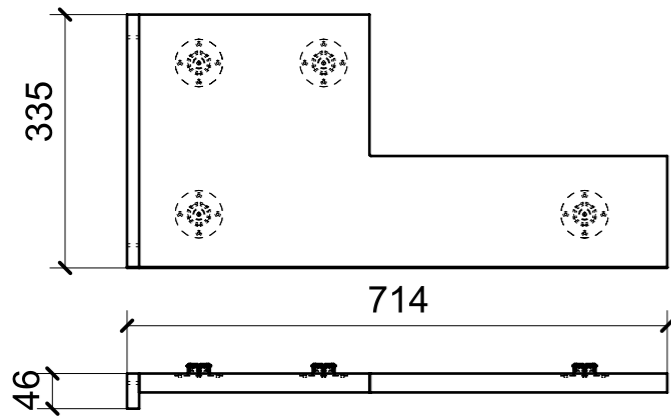

FERRAMENTA	QTY
FITLOCK M_MASCHERPA_3MM_6020202101	4

**MG\_AE04**

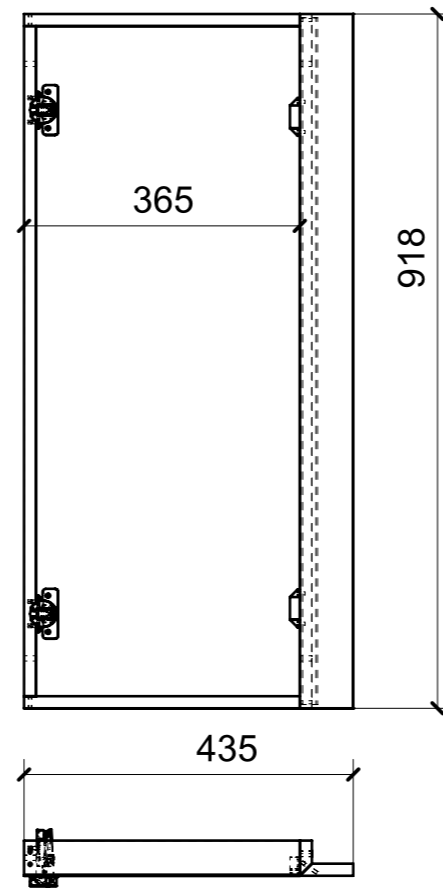

FERRAMENTA	QTY
CALAMITA SEALED MAGNETIC_TECNOPARTNER_MC-JM50-BL	2
MD299_GR06_R01_AE01_14	1
MD299_GR06_R01_AE01_12	1
CERNIERA 94° PIANA AMMORTIZZATA_HAFELE_329_49_310	2
BASE_6_HAFELE_329_84_026	2
VITE 4MAX8 ANKOR BORGHI X CERNIERA PIANA	4
BUSSOLA 5MA ANKOR BORGHI X CERNIERA PIANA	4

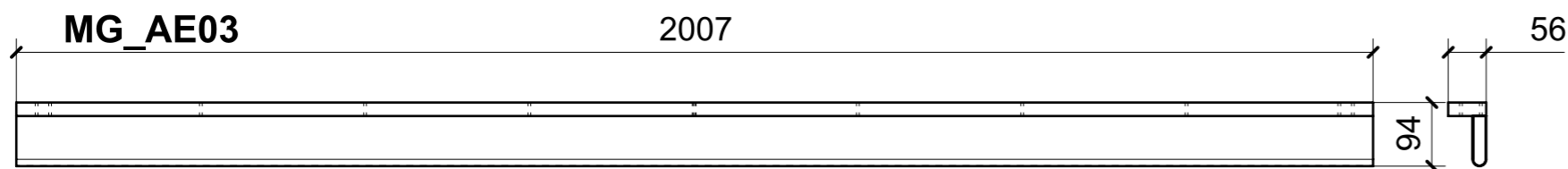
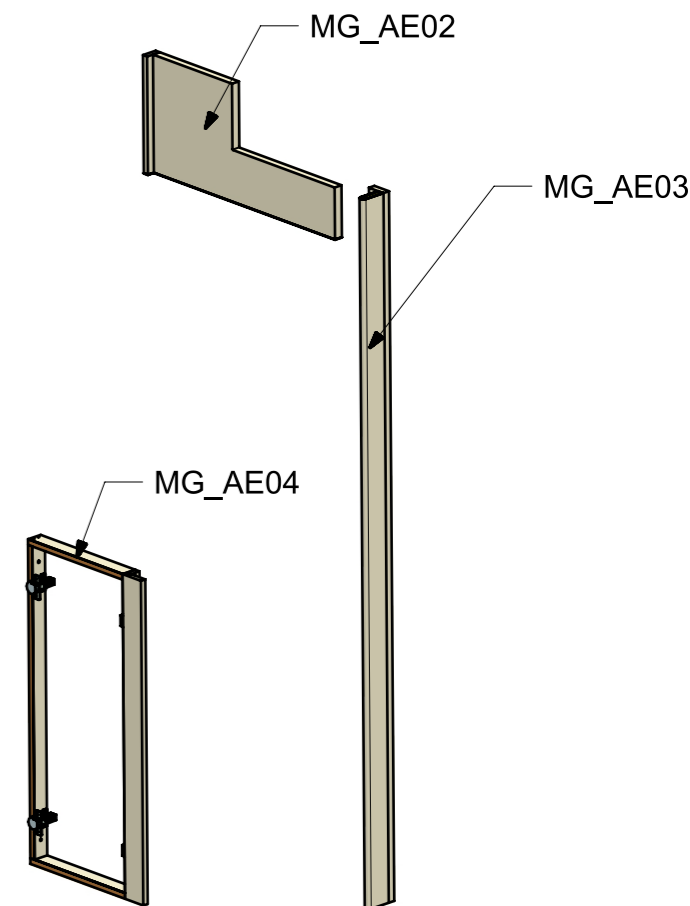

LOCALE	CODICE	DESCRIZIONE COMPONENTE	FINITURA	Q.TA
CABINA ARMATORE	MD299_R01_AE01	RIVESTIMENTO PARETE TV	LASTRA SCURA	1

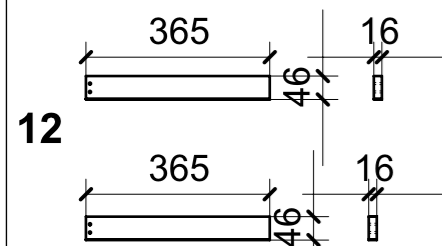
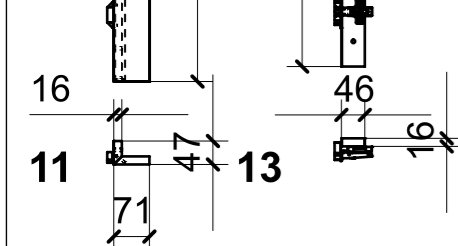
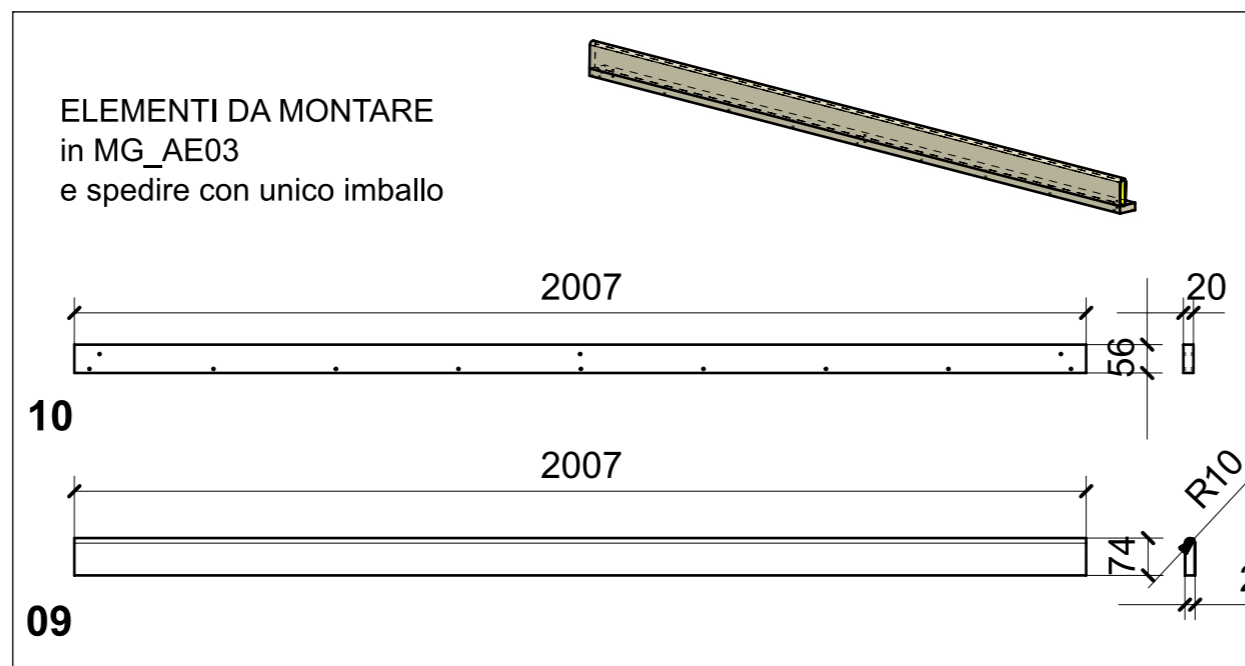
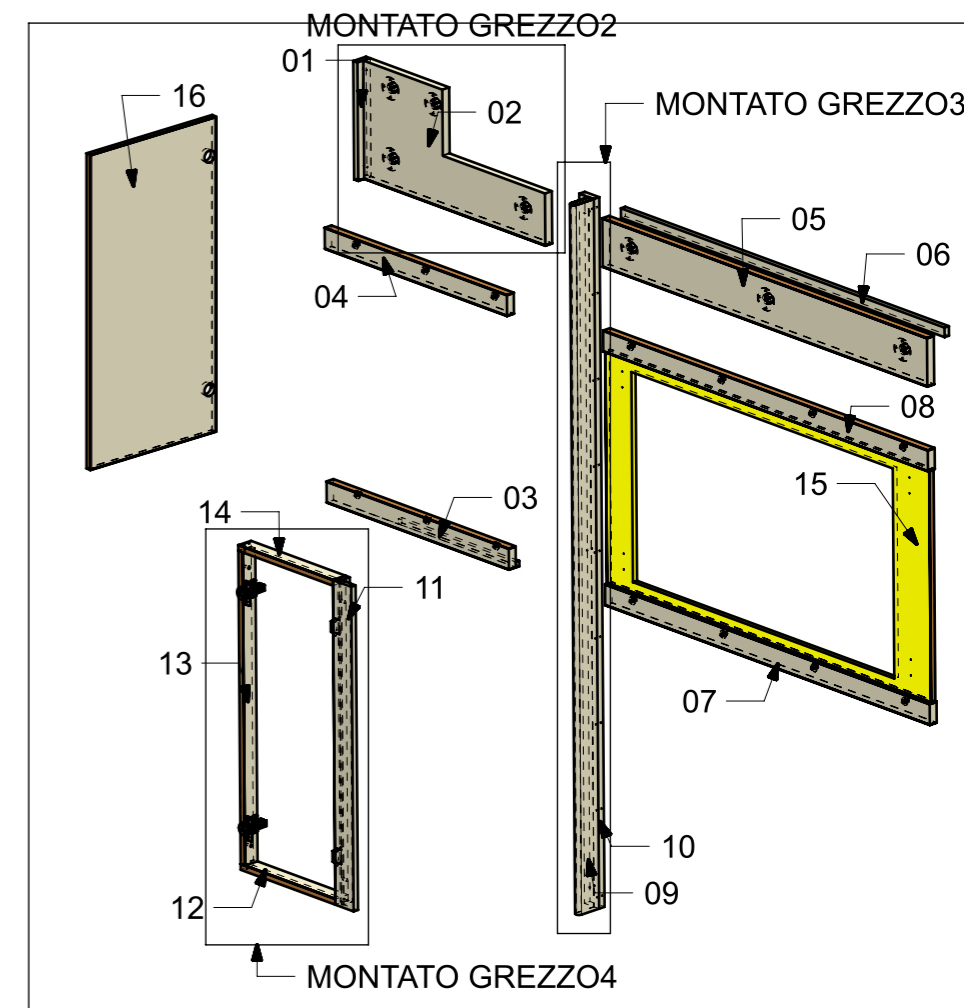
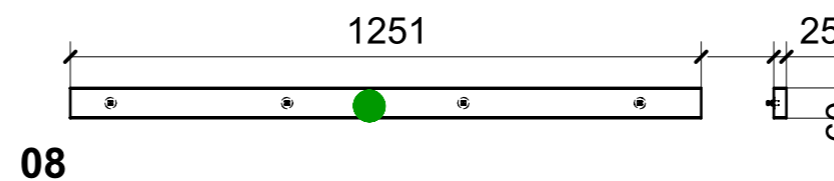
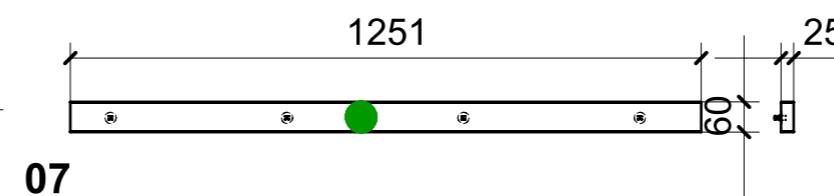
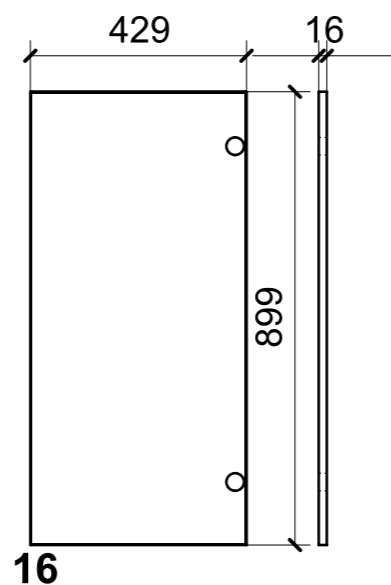
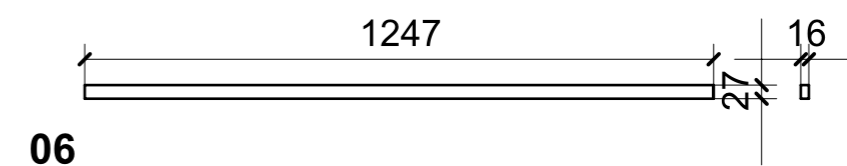
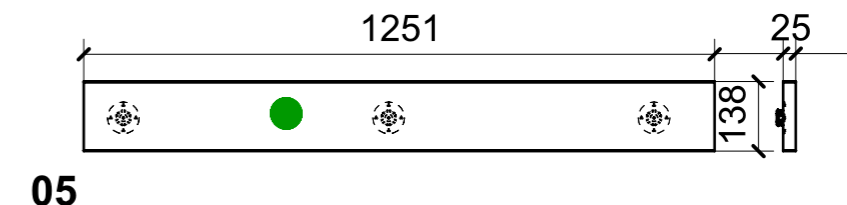
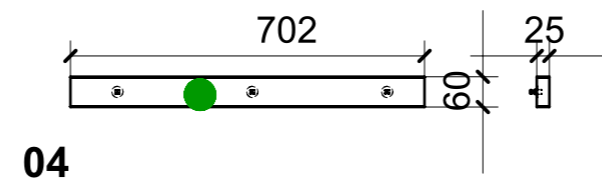
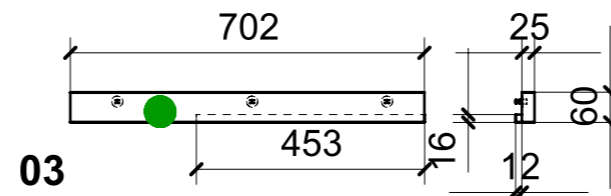
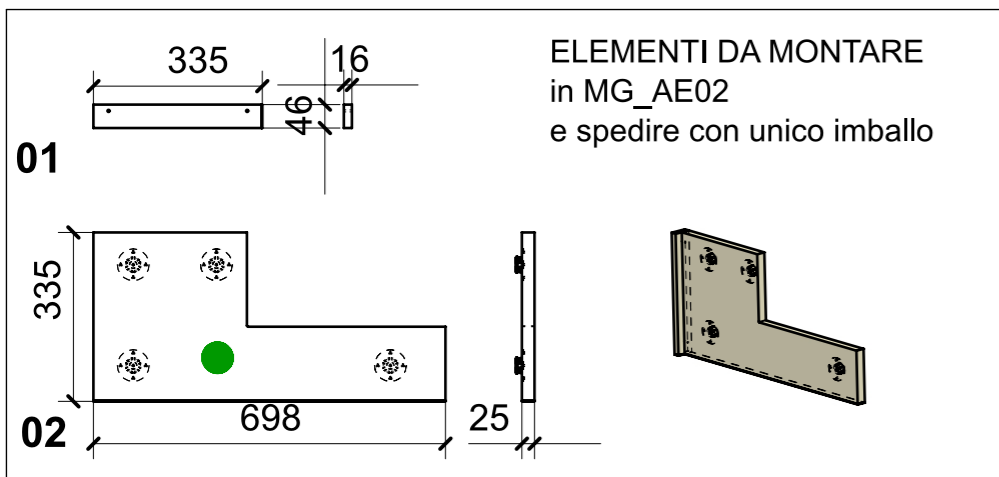

FERRAMENTA	QTY
BASE_6_HAFELE_329_84_026	2
BUSSOLA 5MA ANKOR BORGHI X CERNIERA PIANA	4
CALAMITA SEALED MAGNETIC_TECNOPARTNER_MC-JM50-BL	2
CERNIERA 94° PIANA AMMORTIZZATA_HAFELE_329_49_310	2
FITLOCK M_MASCHERPA_3MM_6020202101	7
MS INCASSO_ITALVIPLA_972_FMPC_M1B	14
VITE 4MAX8 ANKOR BORGHI X CERNIERA PIANA	4

VERNICIATURA LASTRA/LACCATI:

● = VERNICIARE 1 LATO + FILI RASATI O BORDATI

NESSUN SIMBOLO = VERNICIARE 2 LATI + FILI RASATI O BORDATI

LOCALE	CODICE	DESCRIZIONE COMPONENTE	FINITURA	Q.TA
CABINA ARMATORE	MD299_R01_AF01	STRUTTURA RIV. BAGNO OSPITI DX	LASTRA SCURA	1

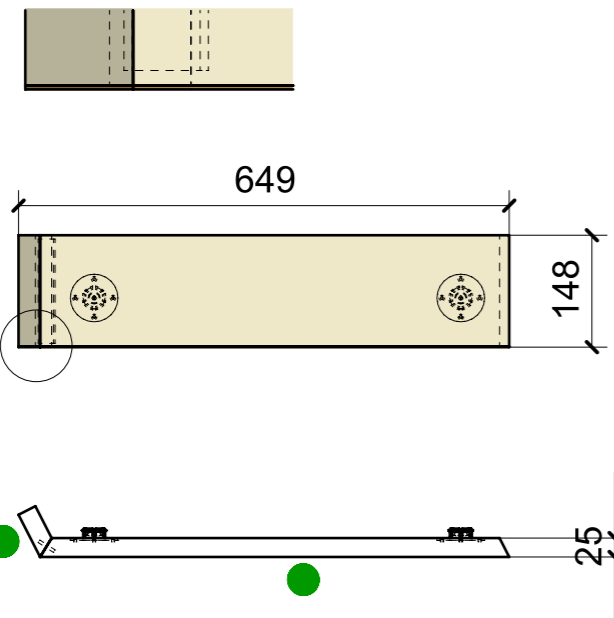

01

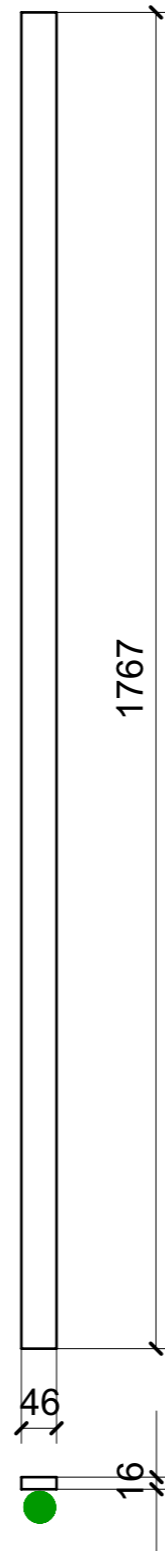

02

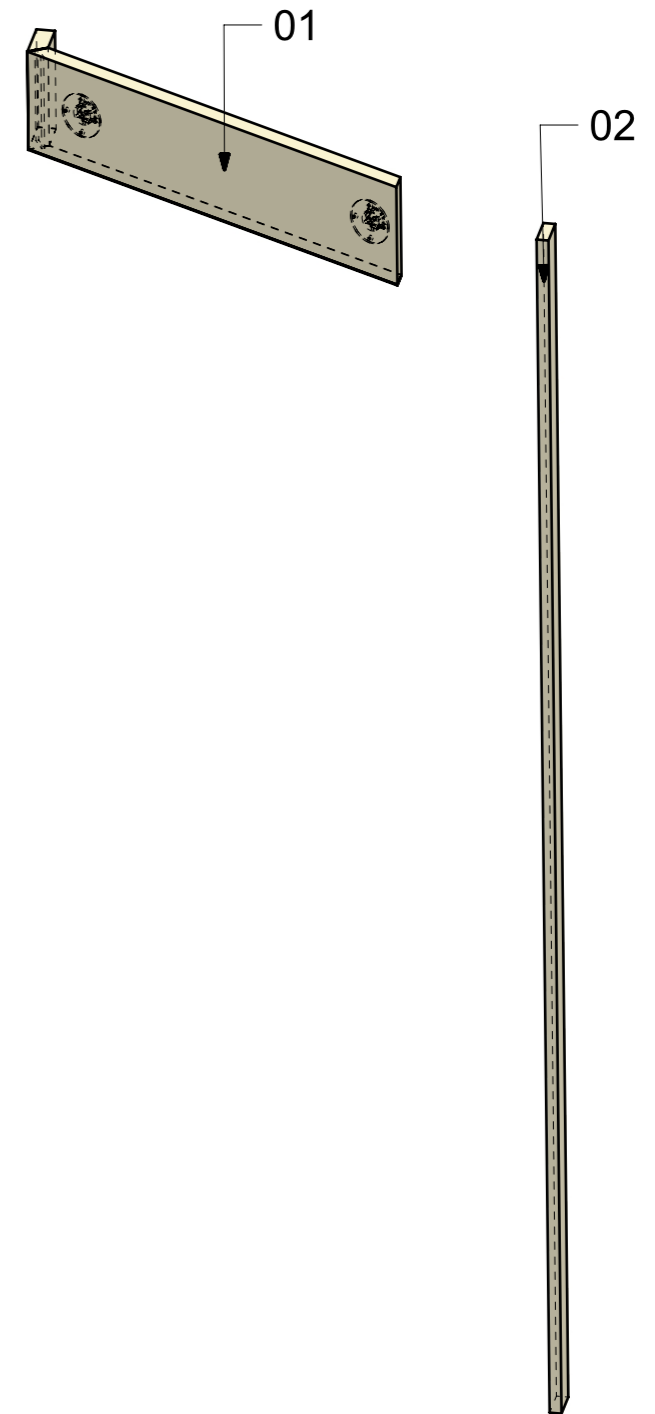

FERRAMENTA	QTY
VITE 6MA X 25 TESTA SVASATA	3
BUSSOLA 6MA X 10 FORO DIAM.8	2
FITLOCK F_MASCHERPA_6020101102	32
FITLOCK M_MASCHERPA_3MM_6020202101	15

VERNICIATURA LASTRA/LAGGATI:

● = VERNICIARE 1 LATO + FILI RASATI O BORDATI

NESSUN SIMBOLO = VERNICIARE 2 LATI + FILI RASATI O BORDATI

LOCALE	CODICE	DESCRIZIONE COMPONENTE	FINITURA	Q.TA
CABINA ARMATORE	MD299_R01_AG01	STRUTTURA RIV.BAGNO ARMATORE	LASTRA SCURA	1

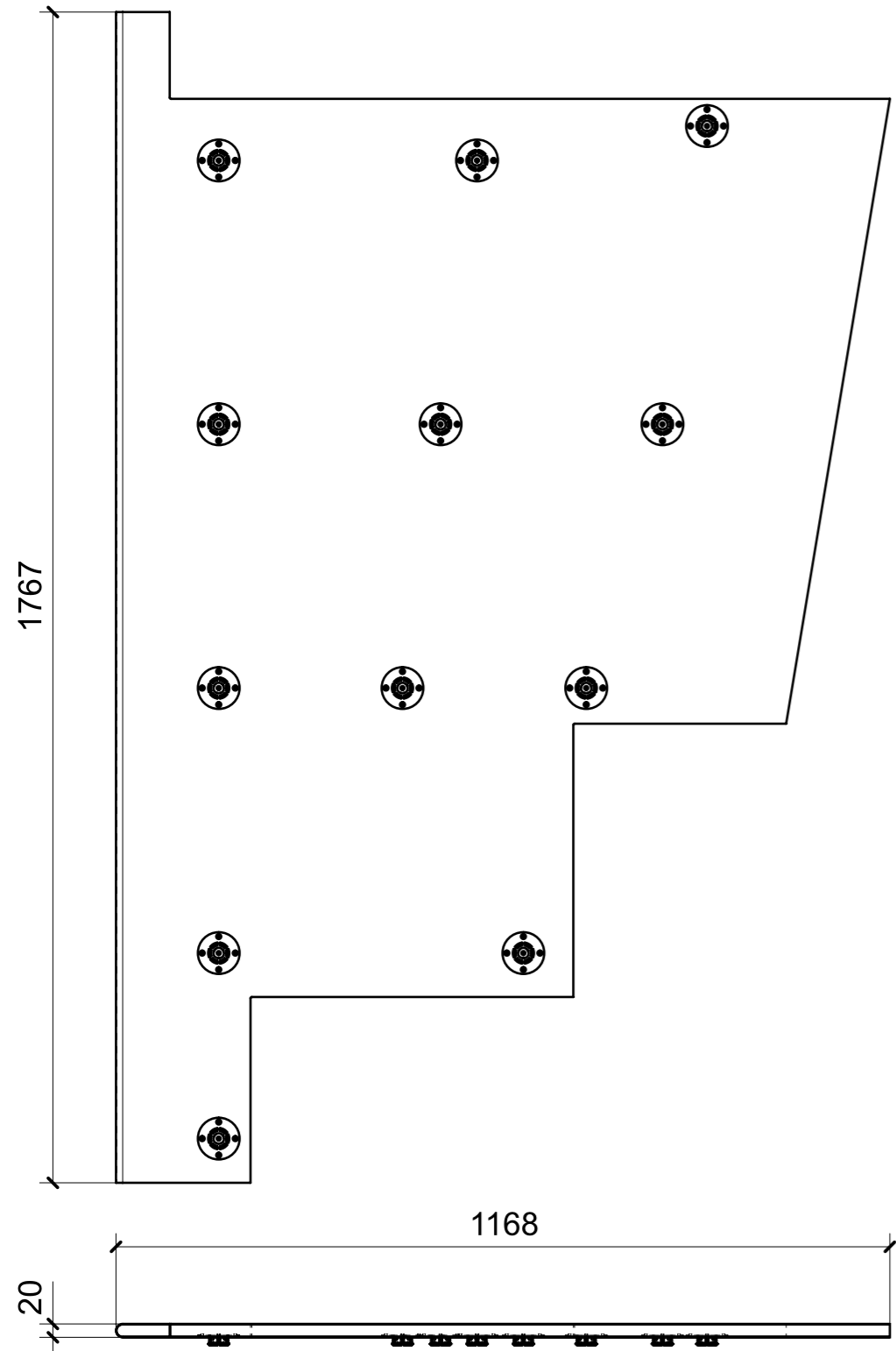

01



02

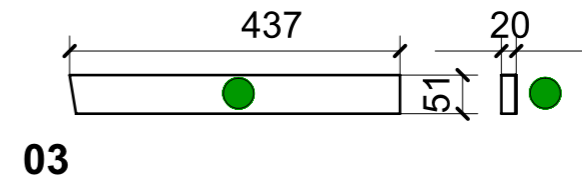

03

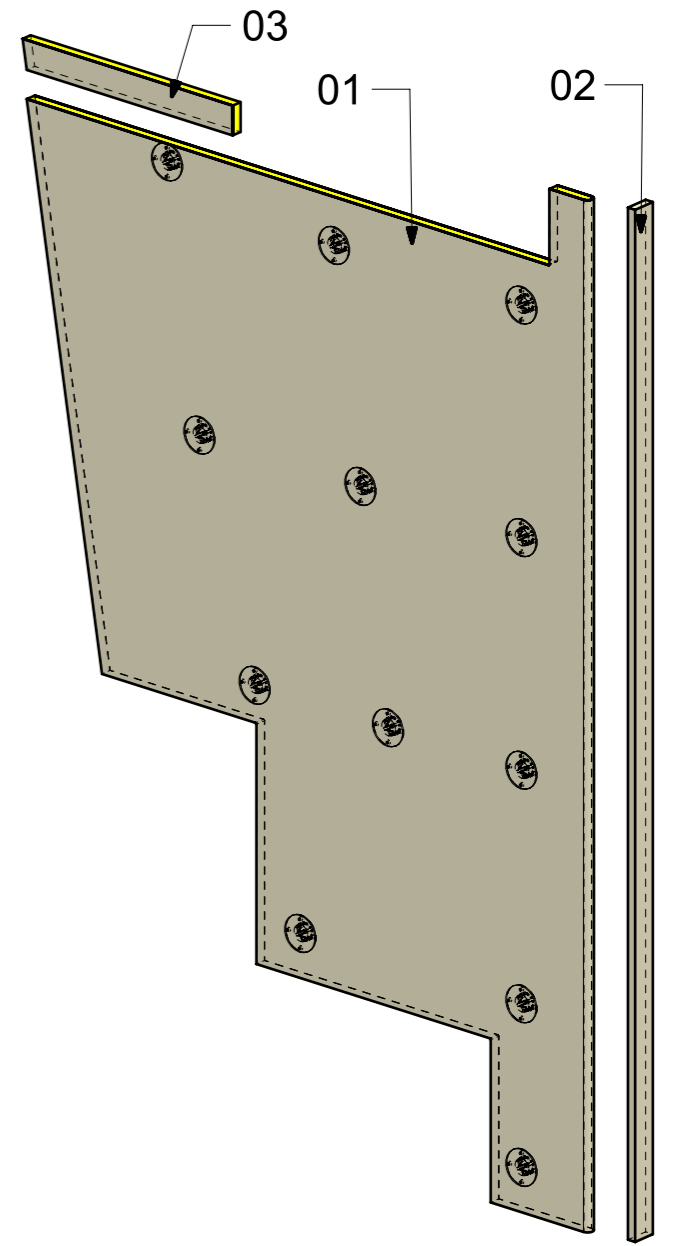

FERRAMENTA	QTY
FITLOCK M_MASCHERPA_3MM_6020202101	12

VERNICIATURA LASTRA/LACCATI:

● = VERNICIARE 1 LATO + FILI RASATI O BORDATI

NESSUN SIMBOLO = VERNICIARE 2 LATI + FILI RASATI O BORDATI

LOCALE	CODICE	DESCRIZIONE COMPONENTE	FINITURA	Q.TA
CABINA ARMATORE	MD299_R01_AH01	STRUTTURA MURATA BASSA DX	LASTRA SCURA	1

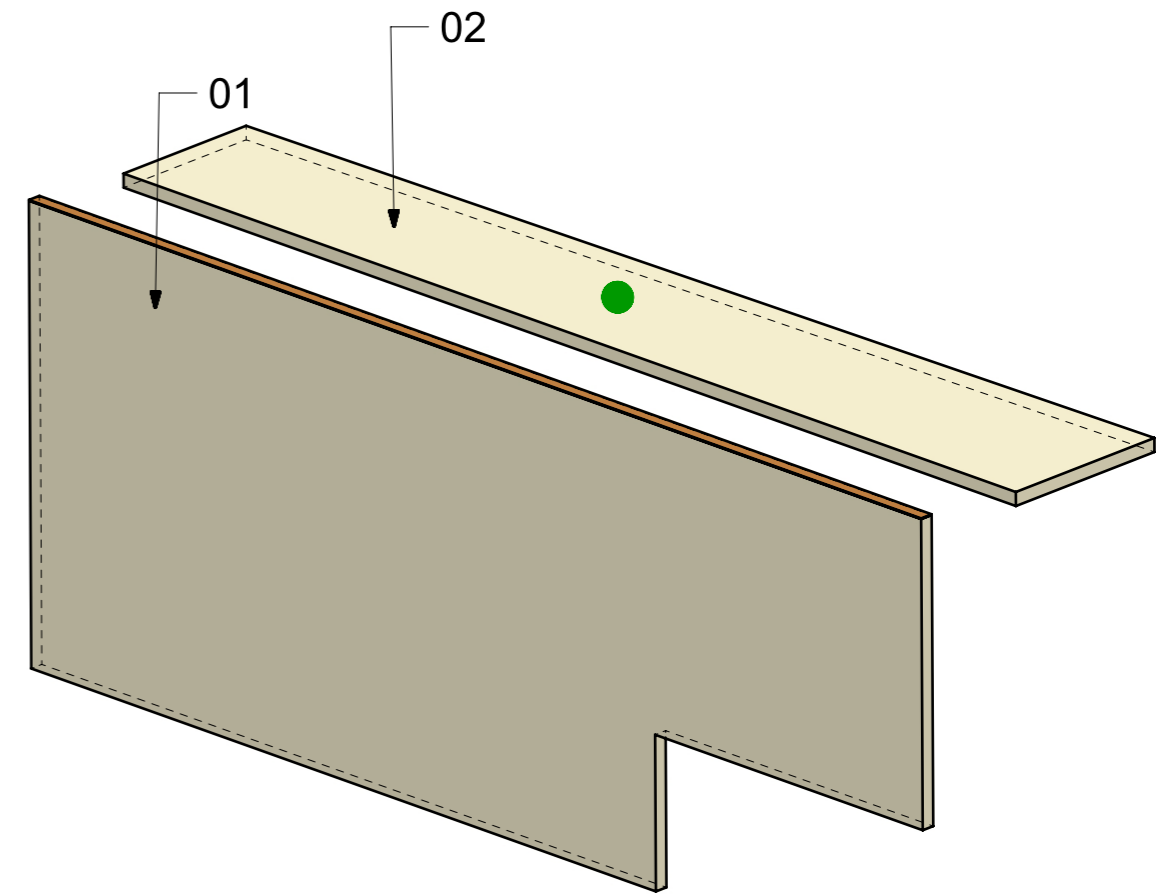
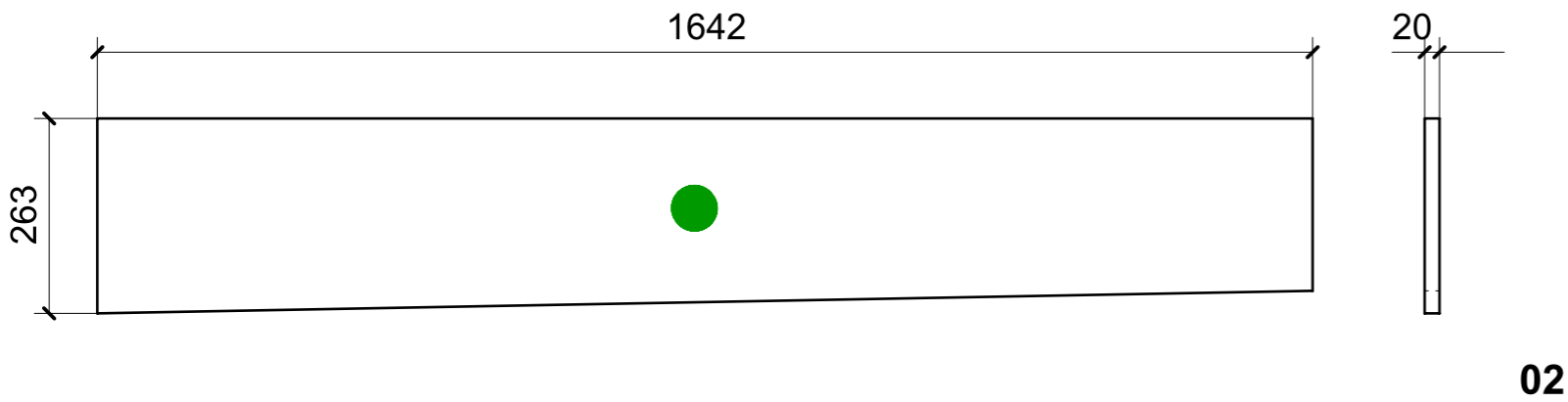
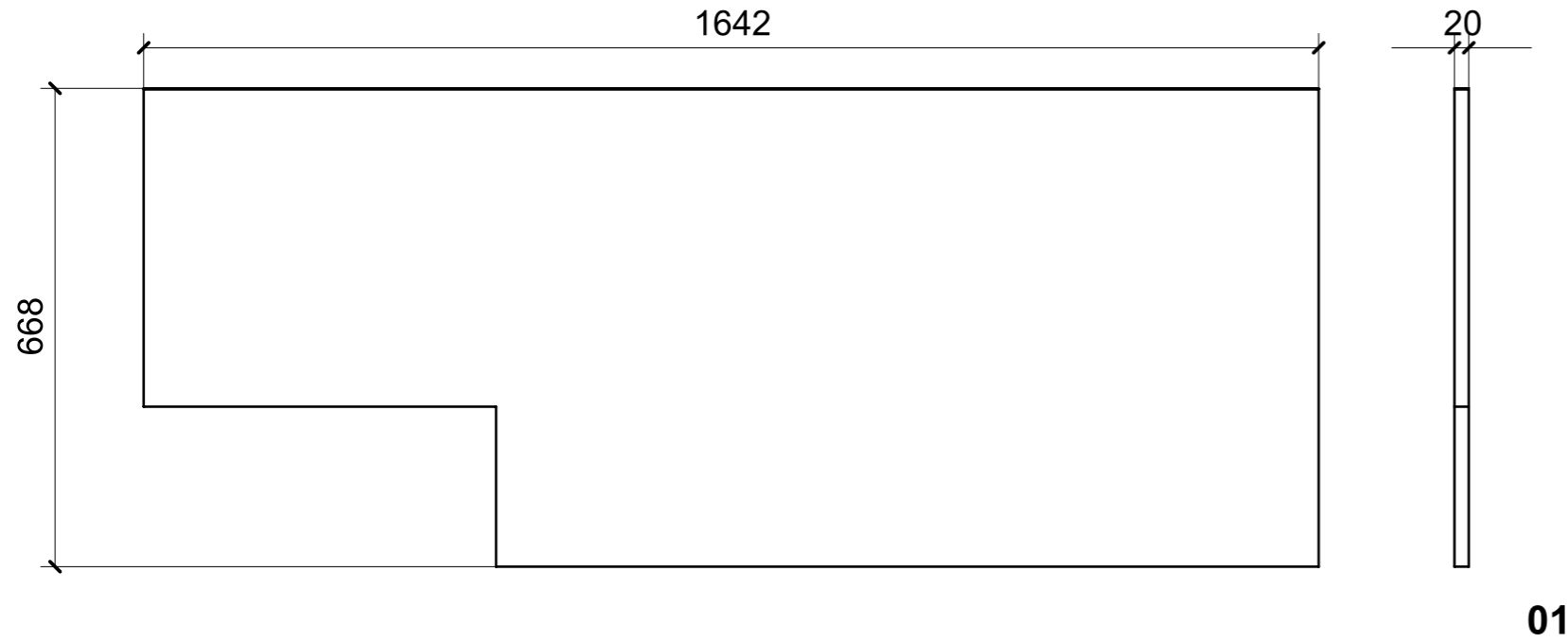

VERNICIATURA LASTRA/LACCATI:

● = VERNICIARE 1 LATO + FILI RASATI O BORDATI

NESSUN SIMBOLO = VERNICIARE 2 LATI + FILI RASATI O BORDATI

LOCALE	CODICE	DESCRIZIONE COMPONENTE	FINITURA	Q.TA
CABINA ARMATORE	MD299_L01_AI01	PONTE AC MURATA DX	LACCATO BIANCO 9010	1

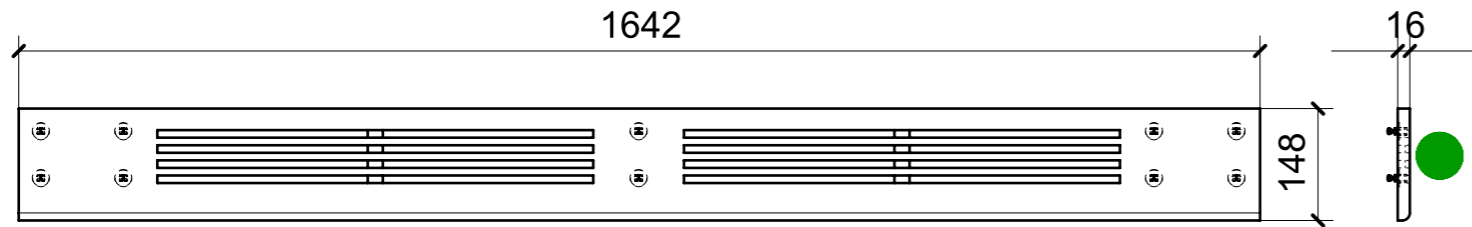

01

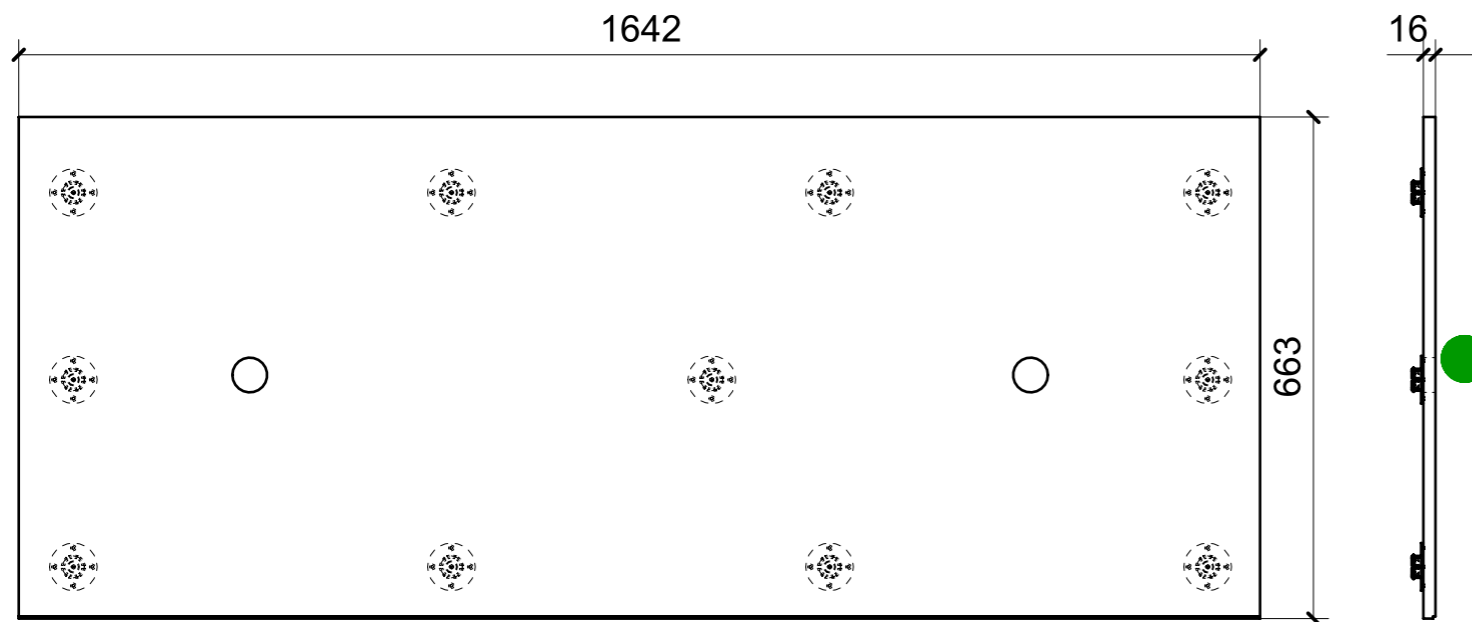
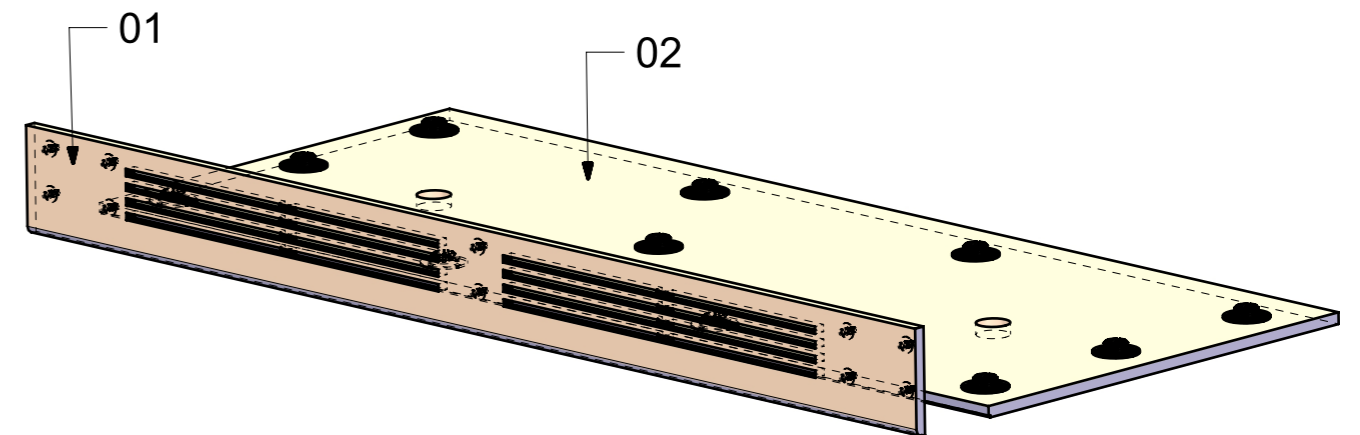

02

FERRAMENTA	QTY
MS INCASSO_ITALVIPLA_972_FMPC_M1B	10
FITLOCK M_MASCHERPA_3MM_6020202101	11

VERNICIATURA LASTRA/LACCATI:

● = VERNICIARE 1 LATO + FILI RASATI O BORDATI

NESSUN SIMBOLO = VERNICIARE 2 LATI + FILI RASATI O BORDATI

LOCALE	CODICE	DESCRIZIONE COMPONENTE	FINITURA	GR.
CABINA ARMATORE	MD299_R01_AK01	RIV. COLONNA SX VAR 2	LASTRA SCURA	9

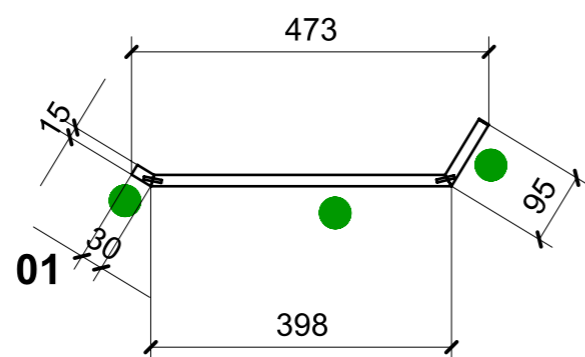
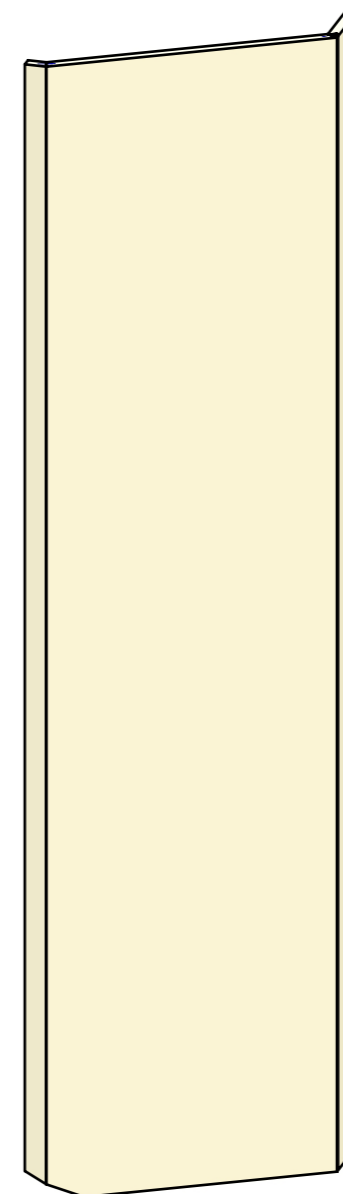
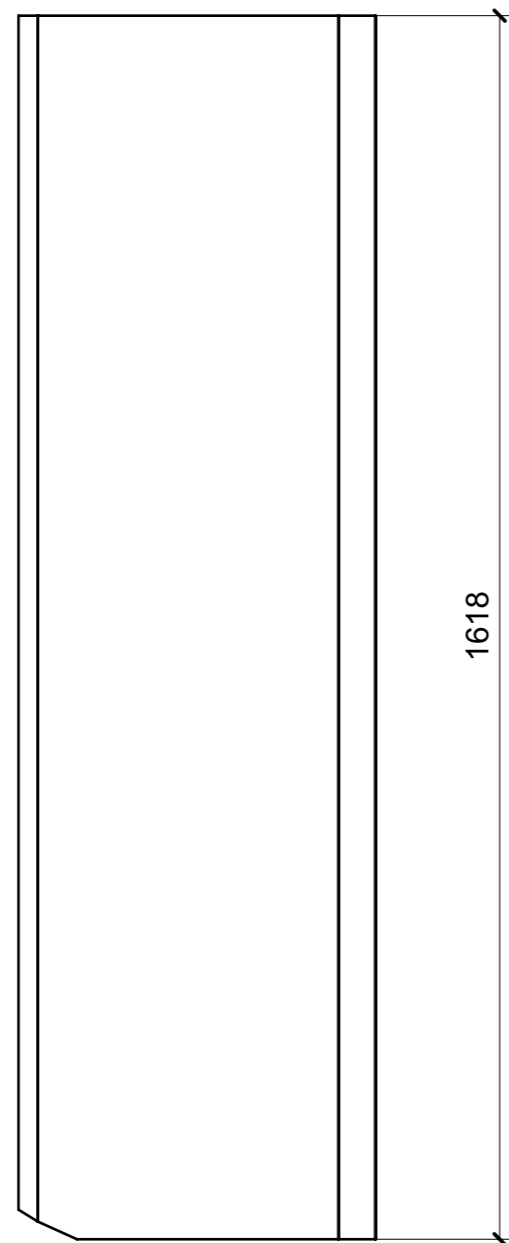

VERNICIATURA LASTRA/LACCATI:

● = VERNICIARE 1 LATO + FILI RASATI O BORDATI

NESSUN SIMBOLO = VERNICIARE 2 LATI + FILI RASATI O BORDATI

LOCALE	CODICE	DESCRIZIONE COMPONENTE	FINITURA	Q.TA
CABINA ARMATORE	MD299_MF_AL	TAVOLINO A RIBALTA MURATA DX_OPT		1

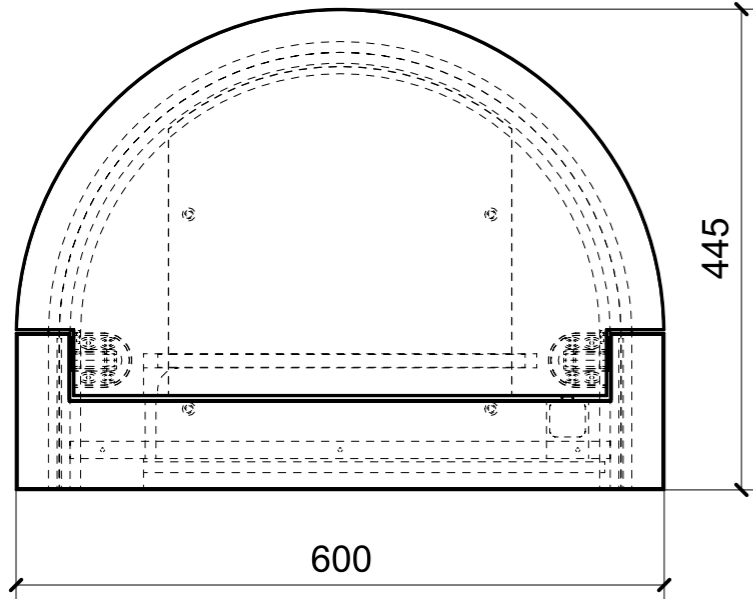
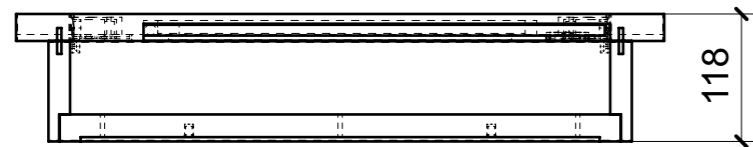

MF\_AL01

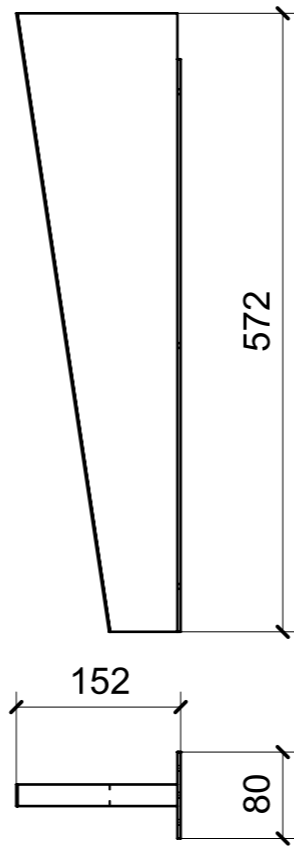

MF\_AL02

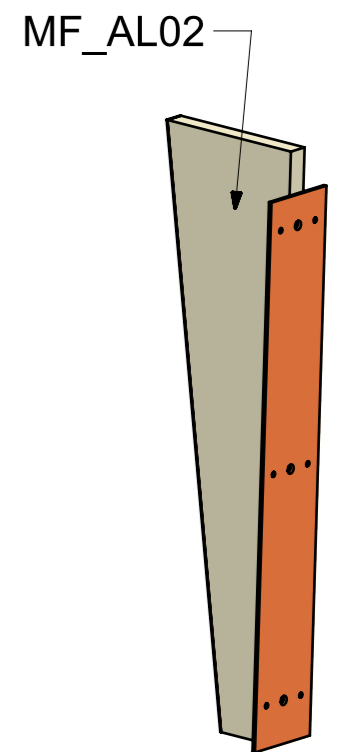
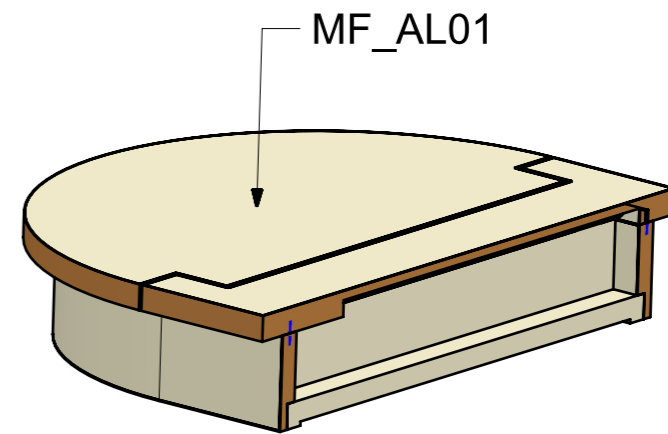

LOCALE	CODICE	DESCRIZIONE COMPONENTE	FINITURA	Q.TA
CABINA ARMATORE	MD299_R01_AL01	TAVOLINO A RIBALTA MURATA DX_OPT	LASTRA SCURA	1

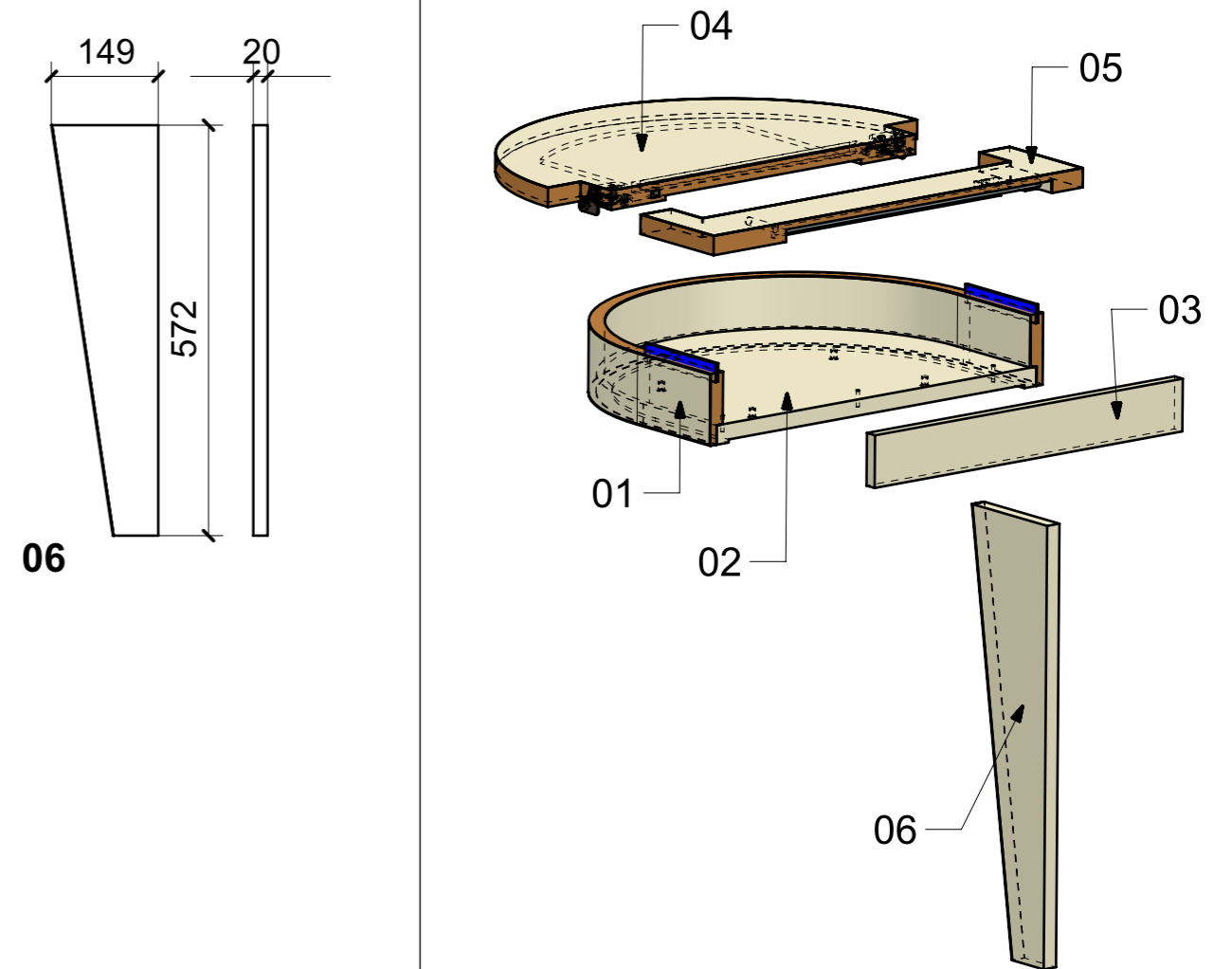
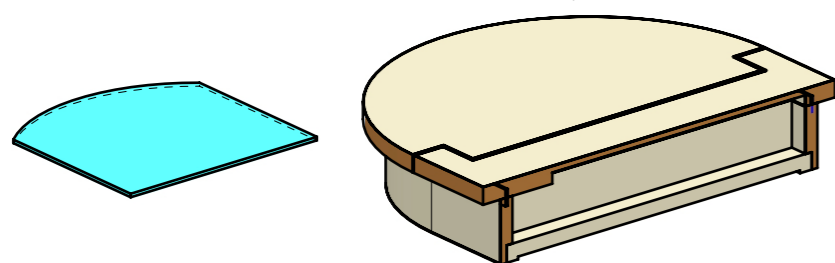
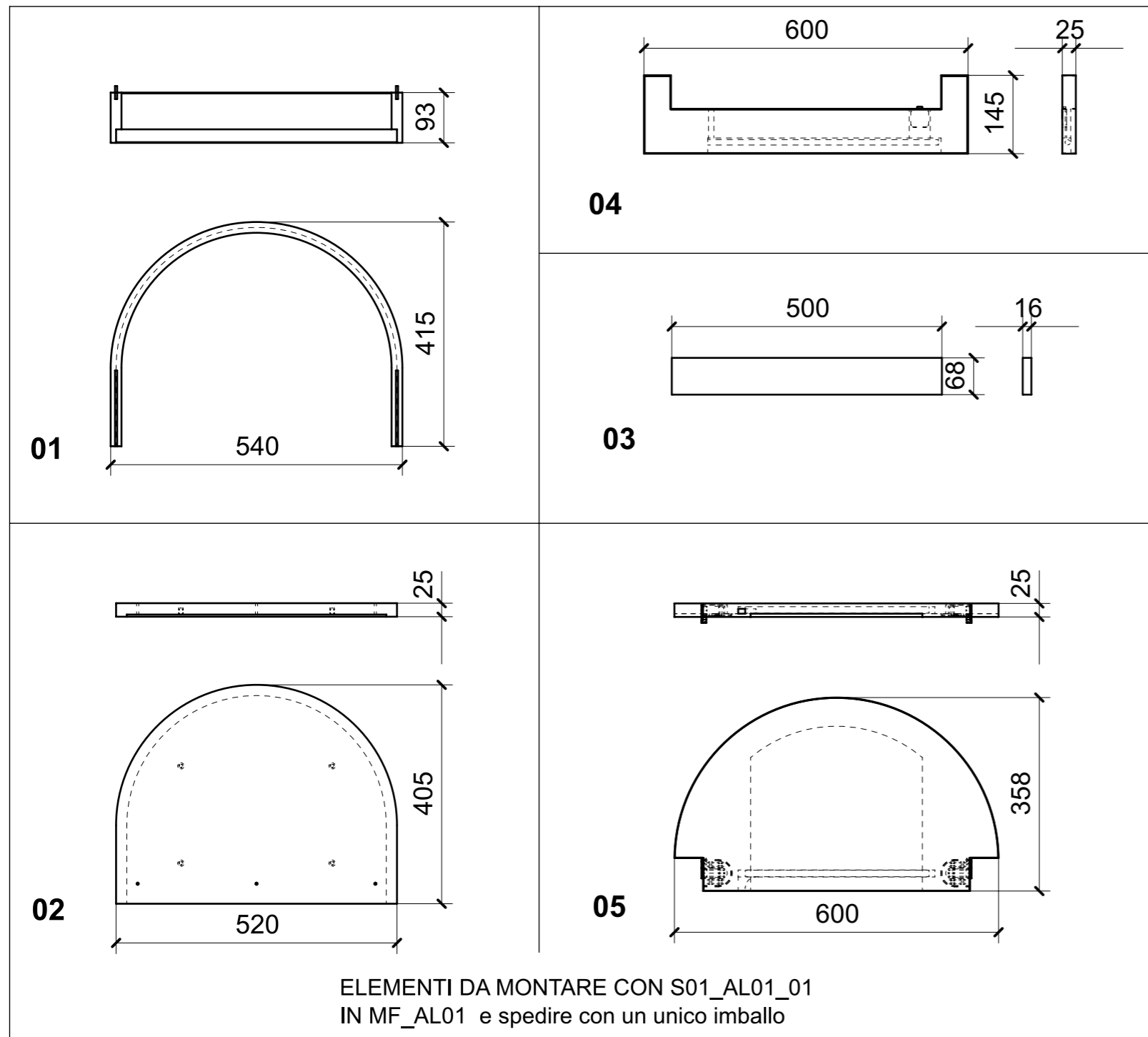

FERRAMENTA	QTY
BUSSOLA 6MA X 10 FORO DIAM.8	4
CP CERNIERE PER COPERCHIO SOFT-CLOSE_HAFELE_356_53_310	1
LAMPADA MICRO MECCANO 24V MM.340 OPAL-STR DA INCASSO SENZA INTERRUPTORE_ESSEPI_	1
MECCANO PROLUNGA CAVETTO 24V MT 2,2 ALIMENTAZIONE	1
INTERRUPTORE CIRCUITO_AMAZON	1

VERNICIATURA LASTRA/LACCATI:

● = VERNICIARE 1 LATO + FILI RASATI O BORDATI

NESSUN SIMBOLO = VERNICIARE 2 LATI + FILI RASATI O BORDATI

LOCALE	CODICE	DESCRIZIONE COMPONENTE	FINITURA	Q.TA
CABINA ARMATORE	MD299_S01_AL01	TAVOLINO A RIBALTA MURATA DX_OPT	SPECCHIO CHIARO	1

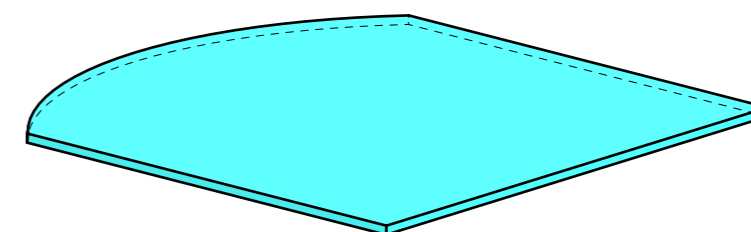
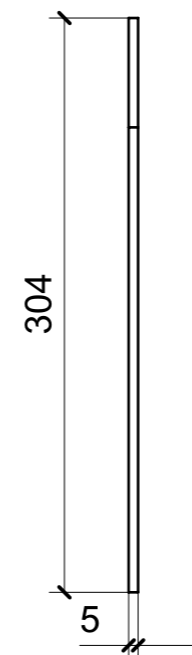
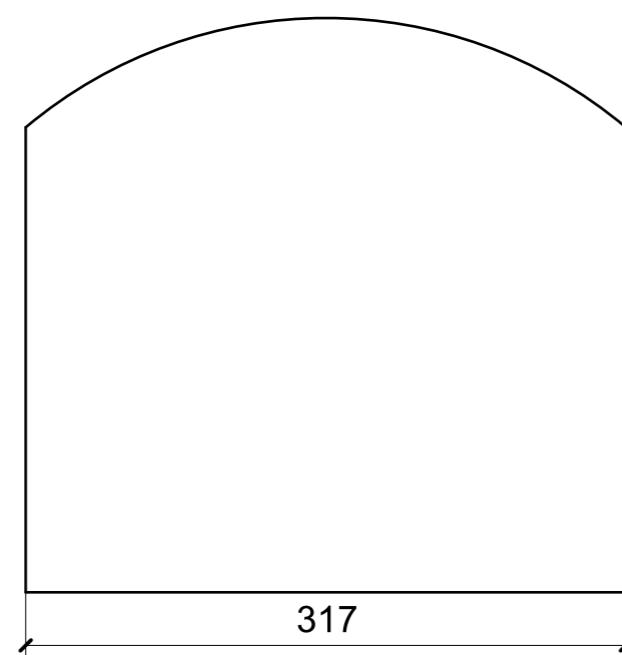

ELEMENTO DA MONTARE CON R01\_AL01\_01/05  
IN MF\_AL01 e spedire con un unico imballo

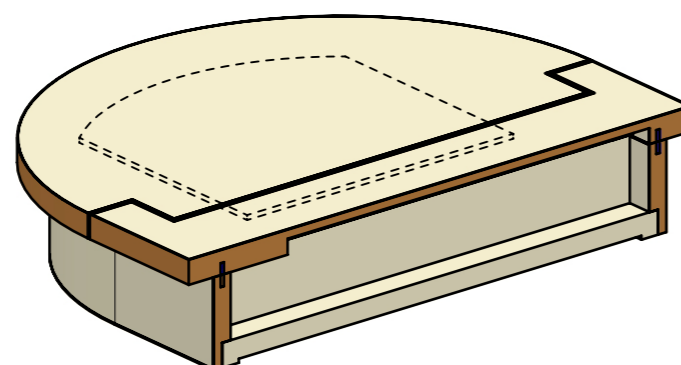

LOCALE	CODICE	DESCRIZIONE COMPONENTE	FINITURA	Q.TA
CABINA ARMATORE	MD299_A01_AL01	TAVOLINO A RIBALTA MURATA DX_OPT	ACCIAIO	1

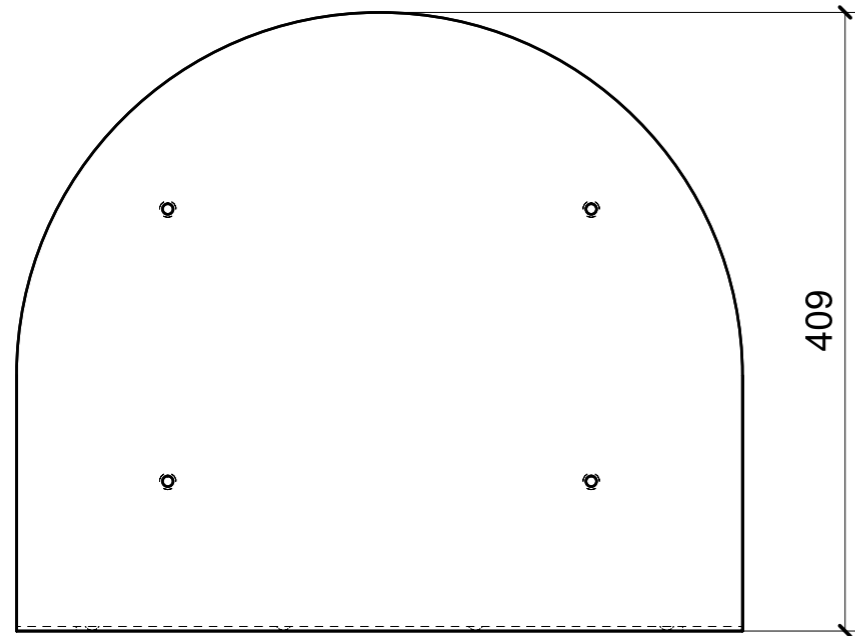
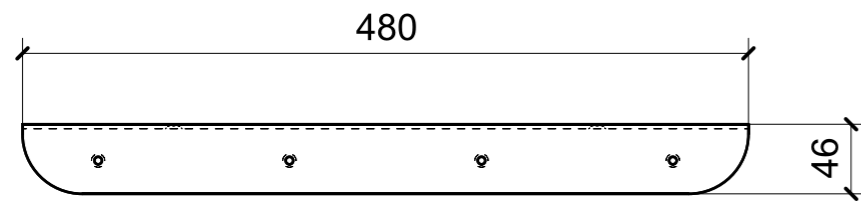

**A05 - ACCIAIO VERNICIATO NERO**

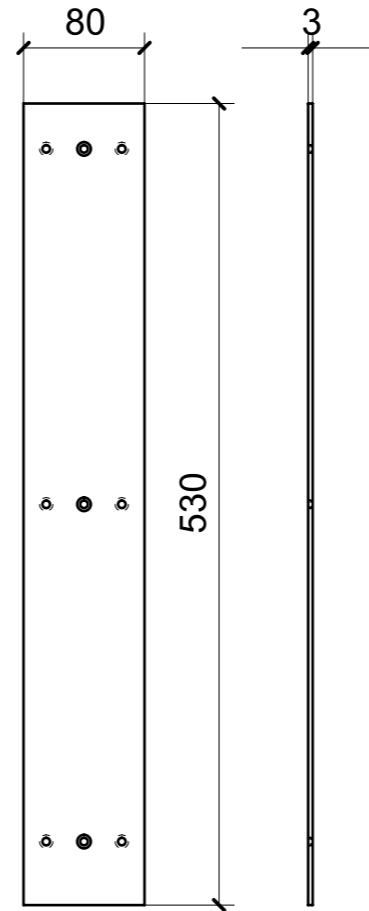

**A06 - ACCIAIO GREZZO**

ELEMENTO DA MONTARE CON R01\_AL01\_06  
IN MF\_AL02 e spedire con un unico imballo

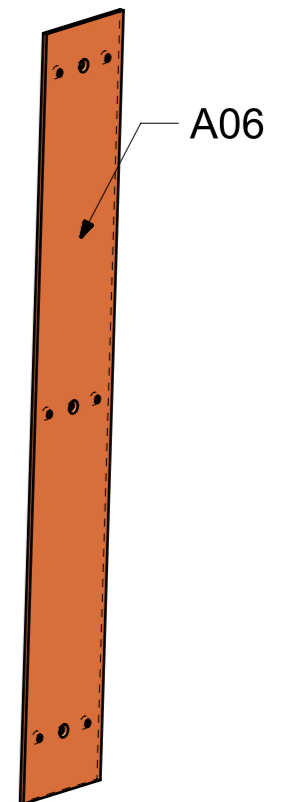
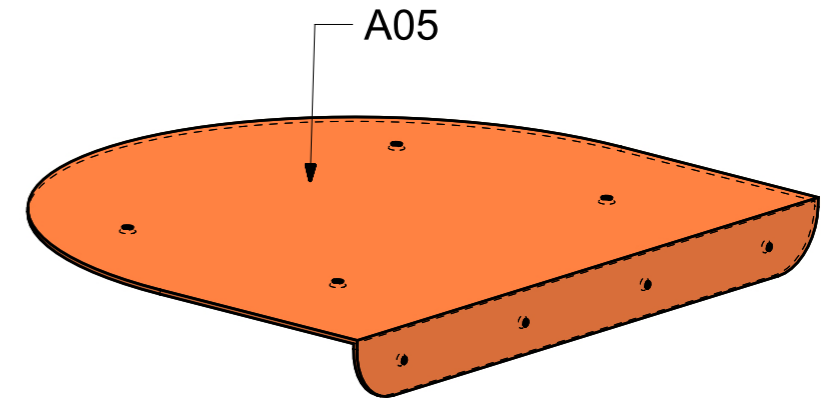
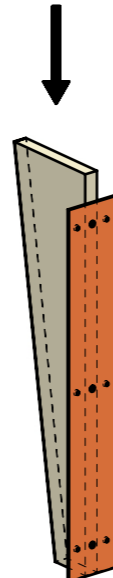

LOCALE	CODICE	DESCRIZIONE COMPONENTE	FINITURA	Q.TA
CABINA ARMATORE	MD299_MF_AO01	STRUTTURA TESTALETTO		1

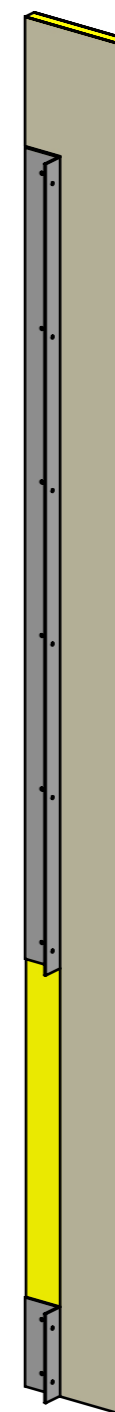
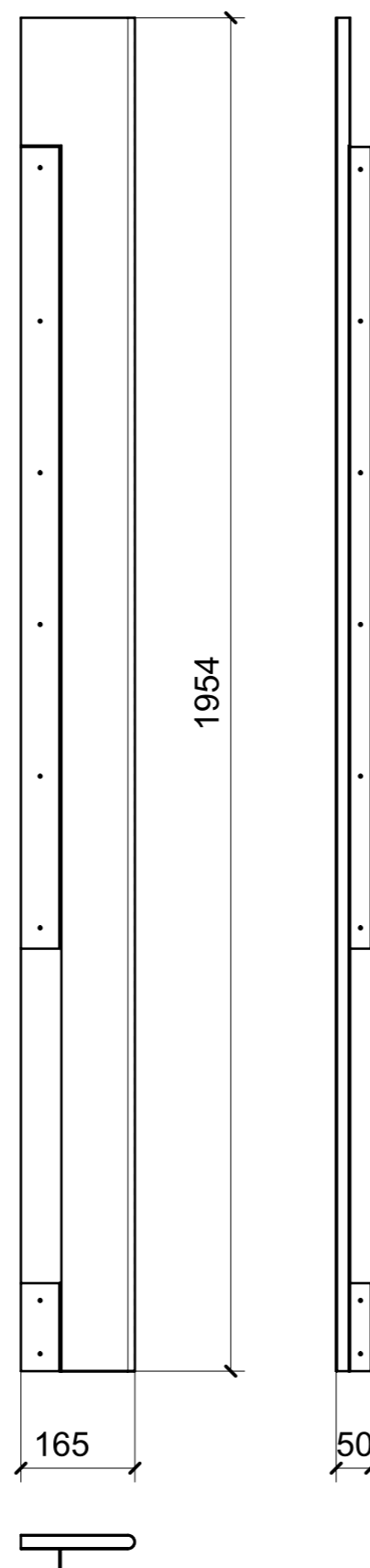

LOCALE	CODICE	DESCRIZIONE COMPONENTE	FINITURA	Q.TA
CABINA ARMATORE	MD299_R01_AO01	STRUTTURA TESTALETTO	LASTRA SCURA	1

01

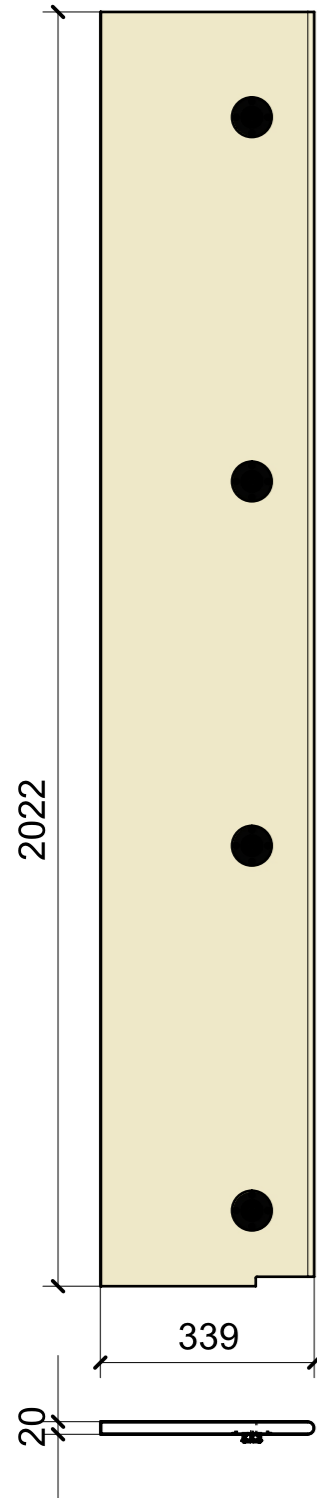

02

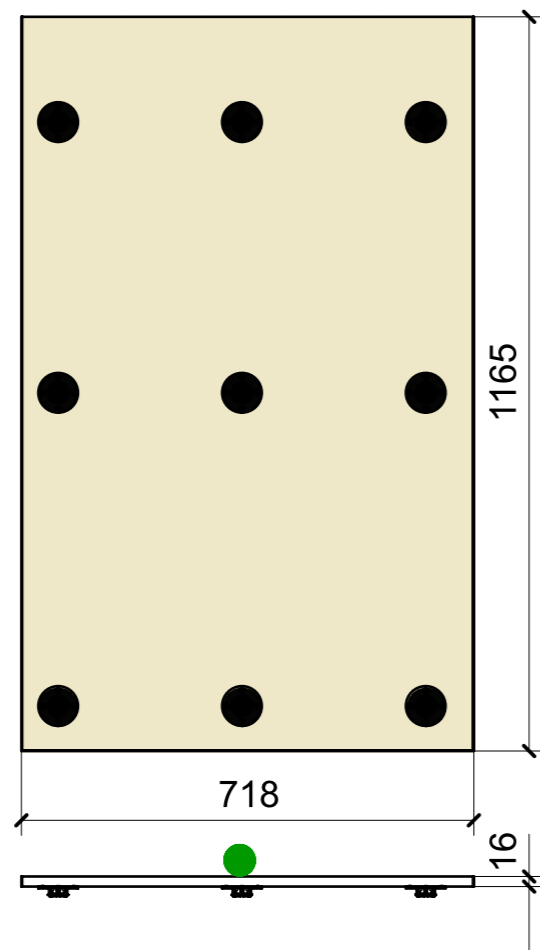

03

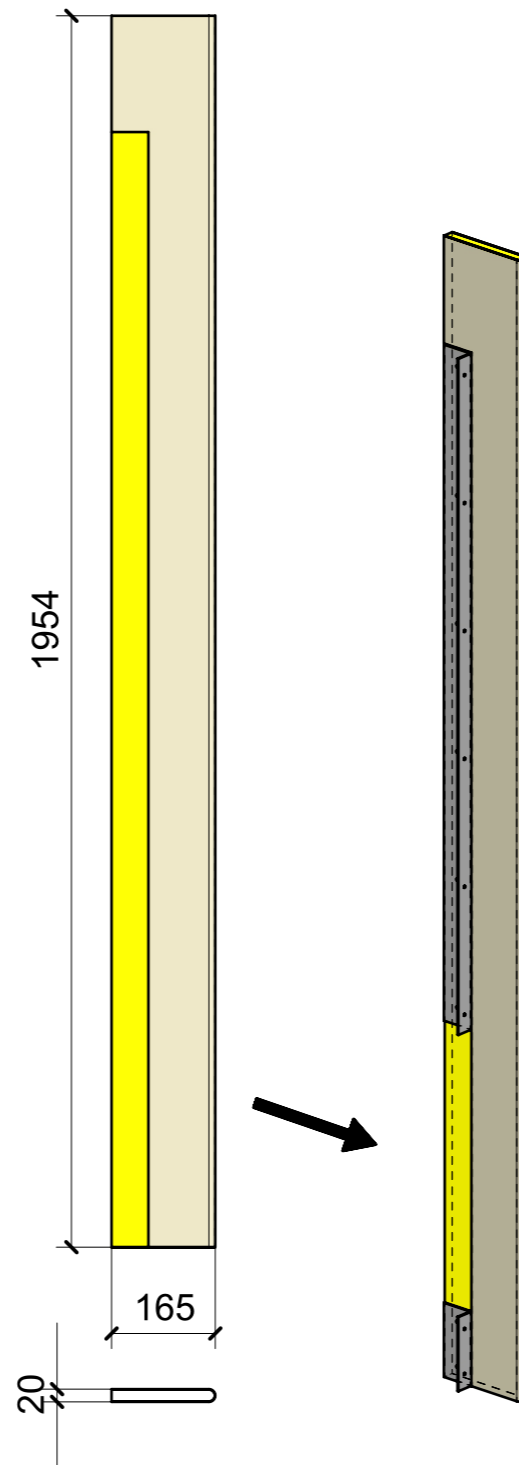

ELEMENTO DA MONTARE CON A07/A08 IN MF\_AO01  
e spedire con unico imballo

01

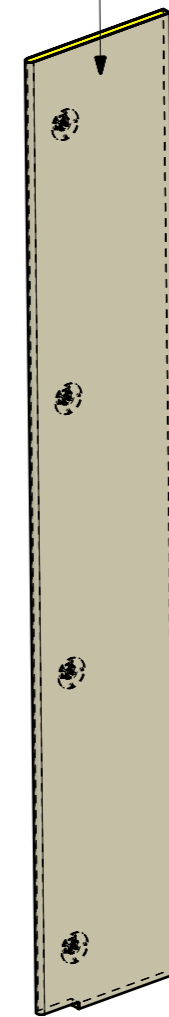

02

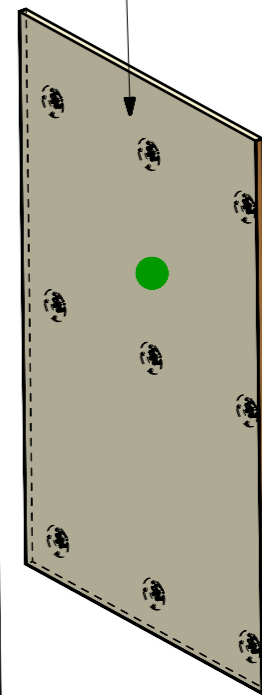

03

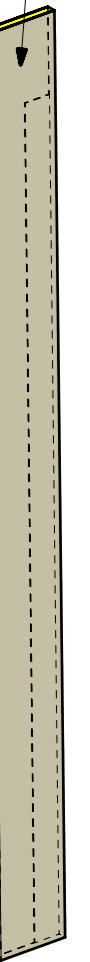

FERRAMENTA	QTY
FITLOCK M_MASCHERPA_3MM_6020202101	13

VERNICIATURA LASTRA/LACCATI:

● = VERNICIARE 1 LATO + FILI RASATI O BORDATI

NESSUN SIMBOLO = VERNICIARE 2 LATI + FILI RASATI O BORDATI

LOCALE	CODICE	DESCRIZIONE COMPONENTE	FINITURA	Q.TA
CABINA ARMATORE	MD299_A07A08_AO01	STRUTTURA TESTALETTO	ACCIAIO GREZZO	1

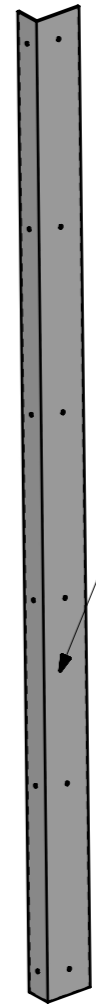
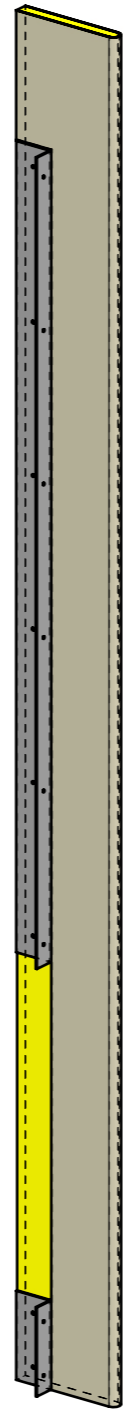
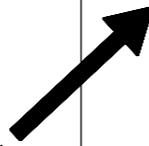
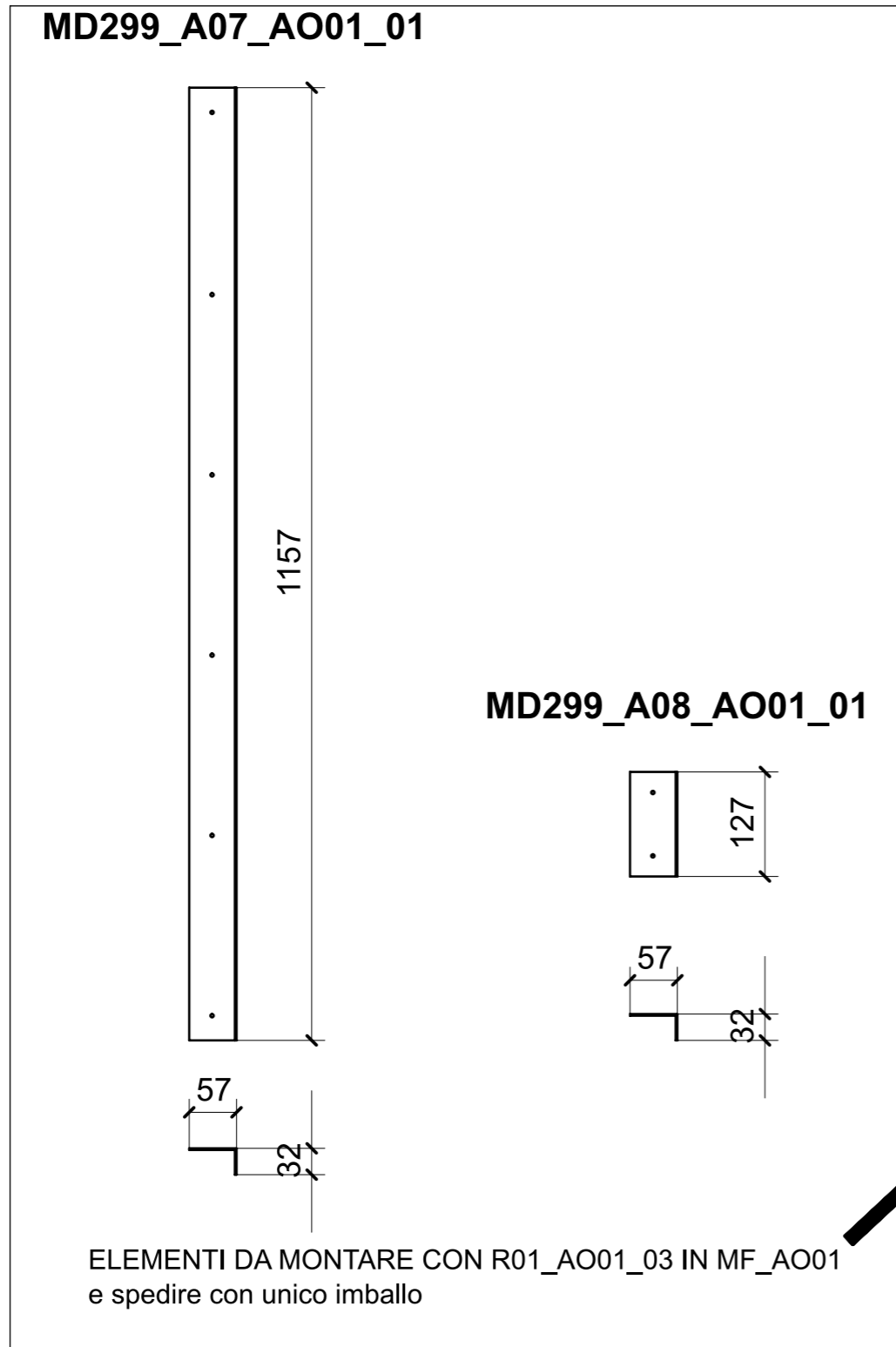

MD299\_A07\_AO01\_01

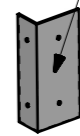

MD299\_A08\_AO01\_01

LOCALE	CODICE	DESCRIZIONE COMPONENTE	FINITURA	Q.TA
CABINA ARMATORE	MD299_R01_AP01	LETTO_STD VAR1	LASTRA SCURA	1

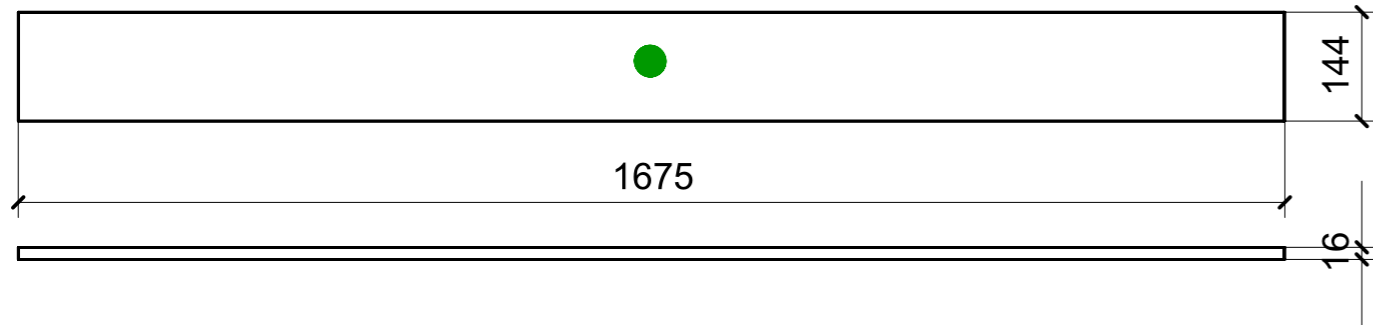

01

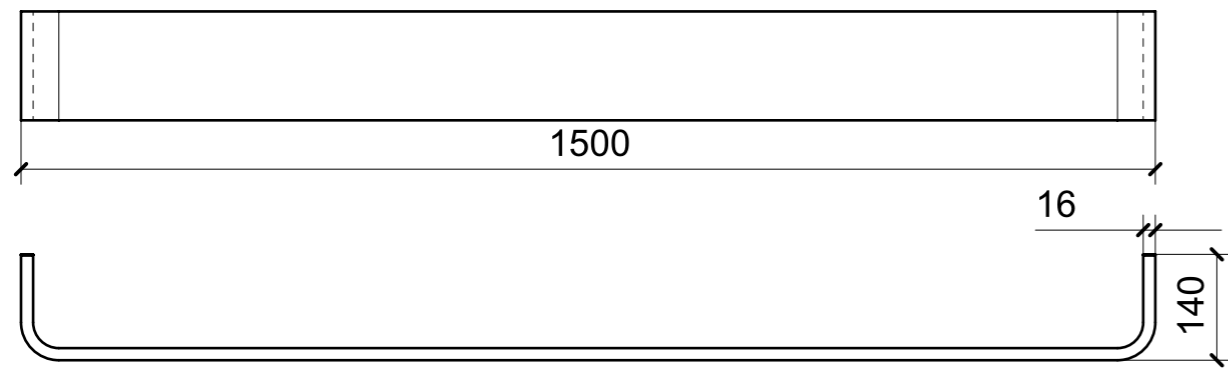

02

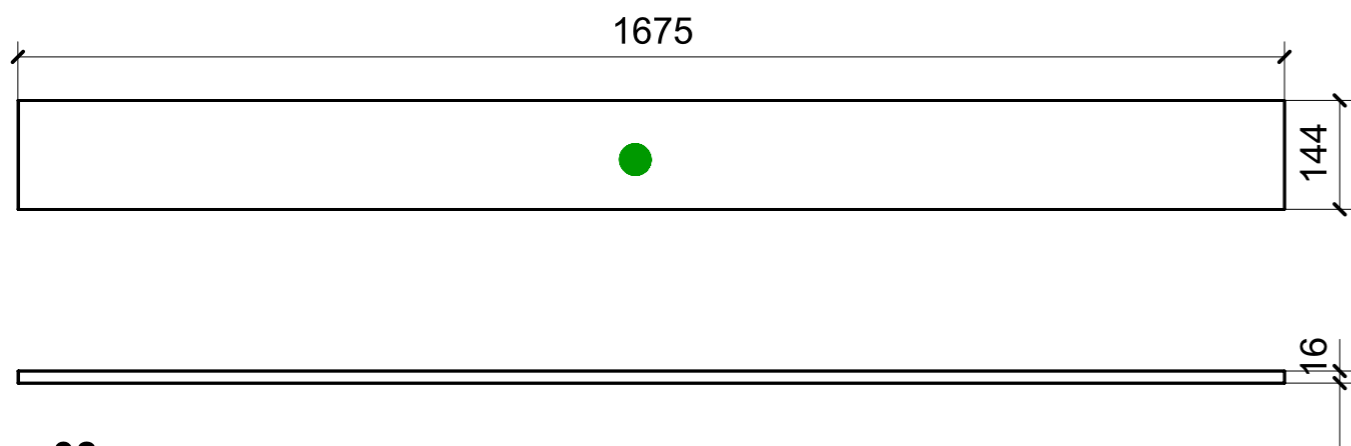

03

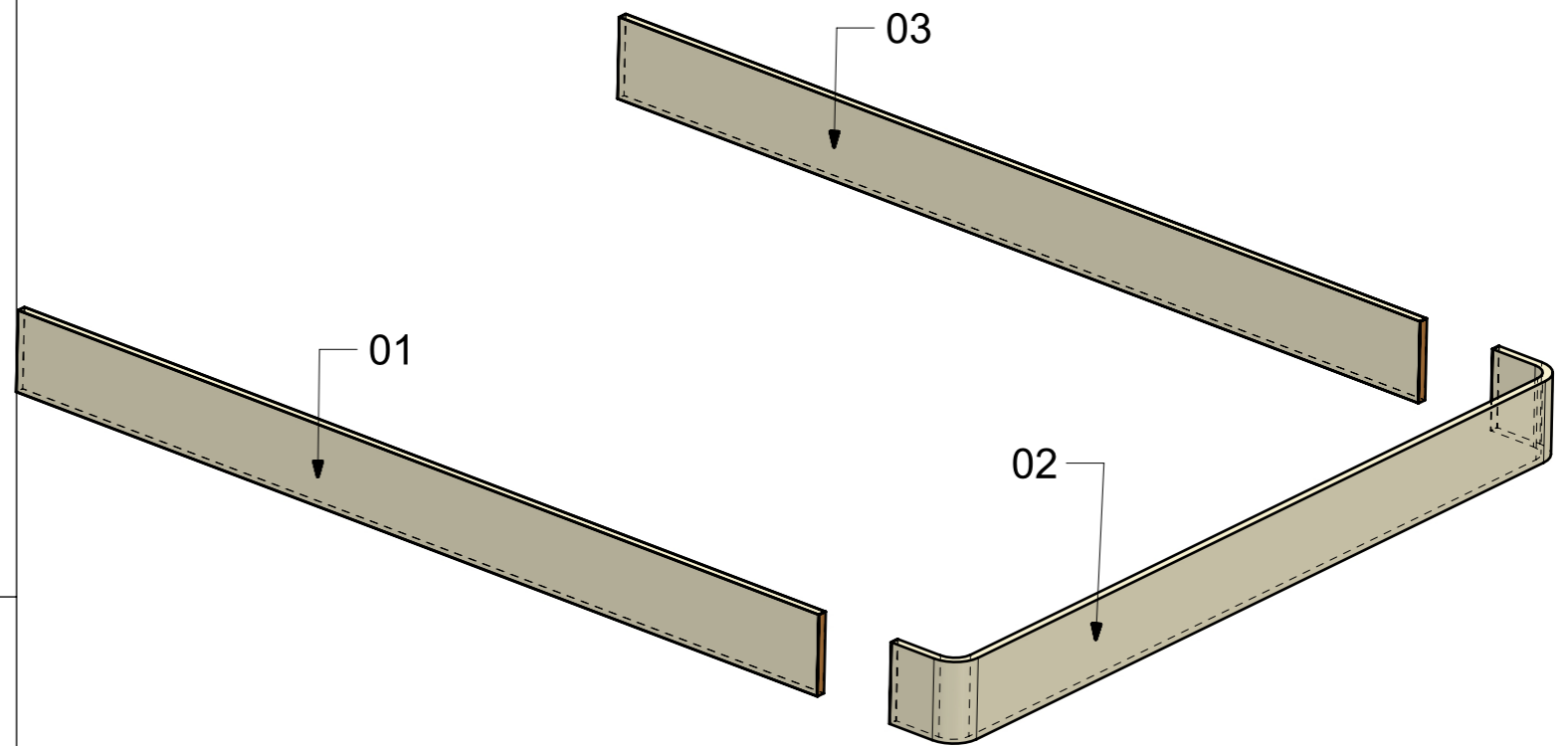

VERNICIATURA LASTRA/LACCATI:

● = VERNICIARE 1 LATO + FILI RASATI O BORDATI

NESSUN SIMBOLO = VERNICIARE 2 LATI + FILI RASATI O BORDATI

LOCALE	CODICE	DESCRIZIONE COMPONENTE	FINITURA	Q.TA
CABINA ARMATORE	MD299_MG_AQ01	COMODINO SX_STD VAR 1		1

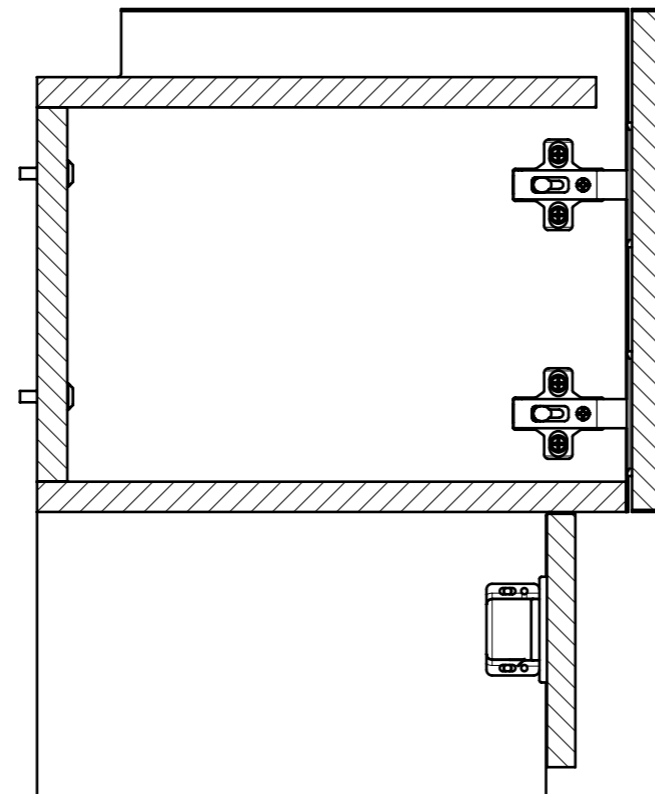
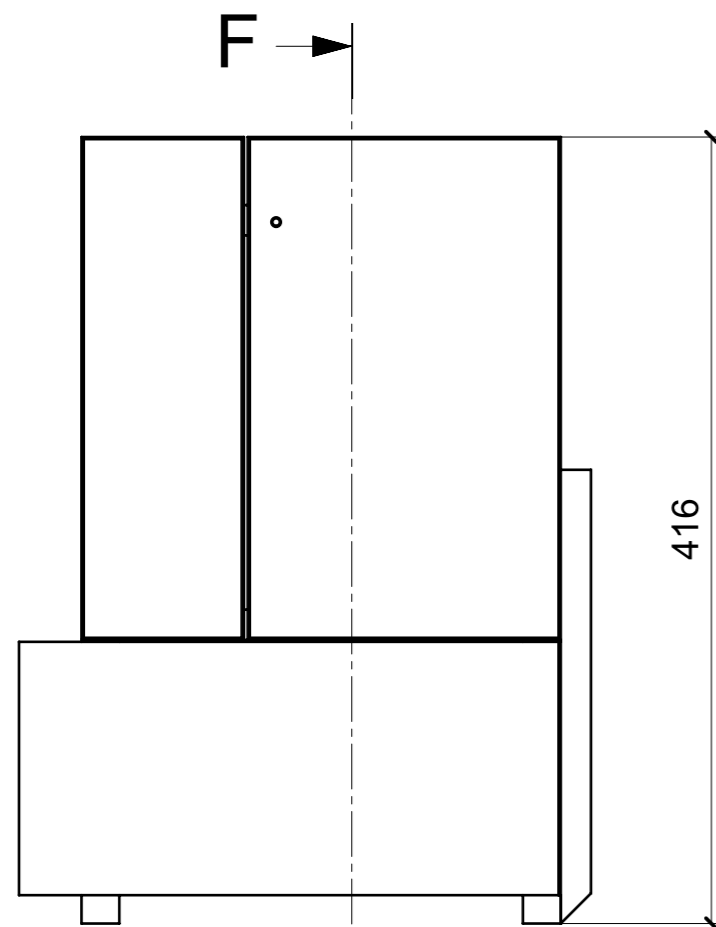

SECTION F-F

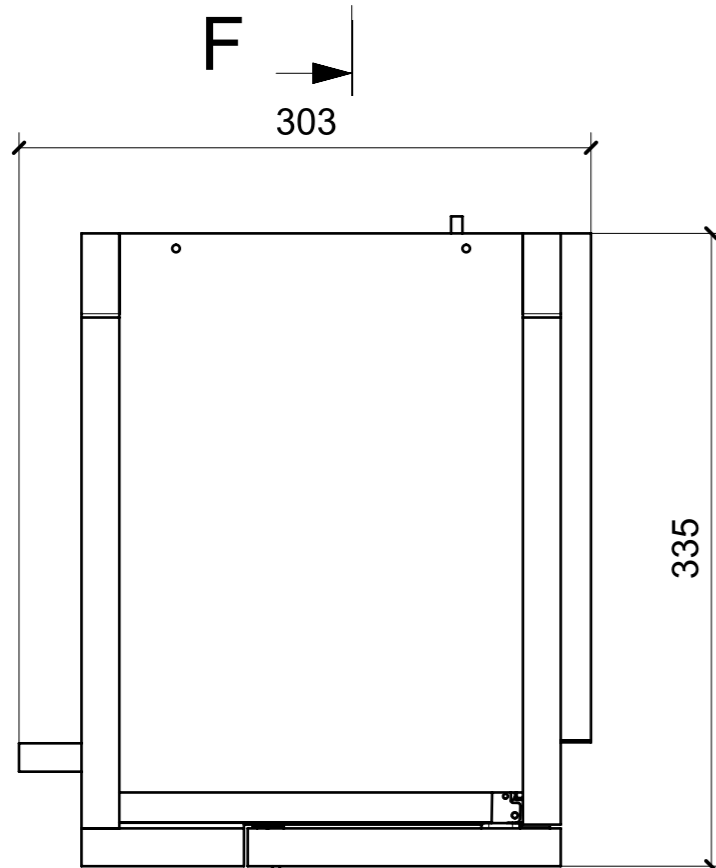
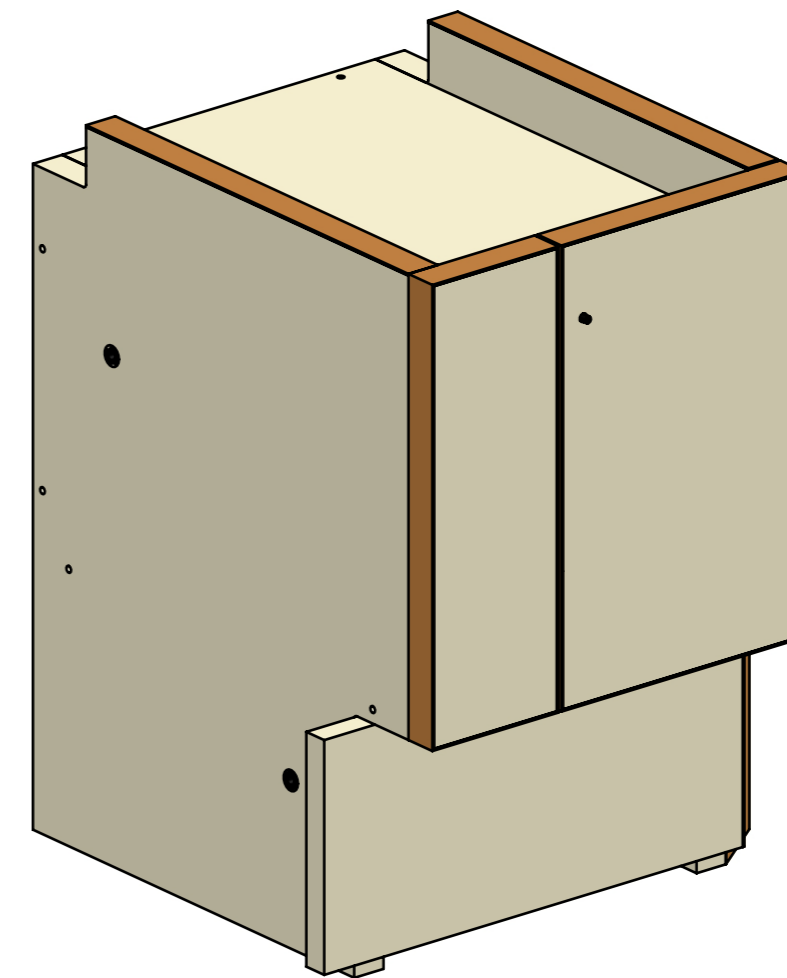

FERRAMENTA	QTY
BASE_0_HAFELE_329_84_020	2
BUSSOLA 5MA ANKOR BORGHI X BASE 0	4
BUSSOLA 5MA ANKOR BORGHI X CERNIERA PIANA	4
BUSSOLA 6MA X 10 FORO DIAM.8	2
CERNIERA 94° PIANA AMMORTIZZATA_HAFELE_329_49_310	2
CHIUSURA A SPINTA_TECHNOPARTNER_SOU C3-203	2
GOMMINO PARACOLPO ANTA	2
VITE 4MA X 25 TESTA SVASATA ESAGONALE NERA	1
VITE 4MAX8 ANKOR BORGHI X BASE 0	4
VITE 4MAX8 ANKOR BORGHI X CERNIERA PIANA	4
VITE 6MA X 25 TESTA BOMBATA	2

LOCALE	CODICE	DESCRIZIONE COMPONENTE	FINITURA	Q.TA
CABINA ARMATORE	MD299_R01_AQ01	COMODINO SX_STD VAR 1	LASTRA SCURA	1

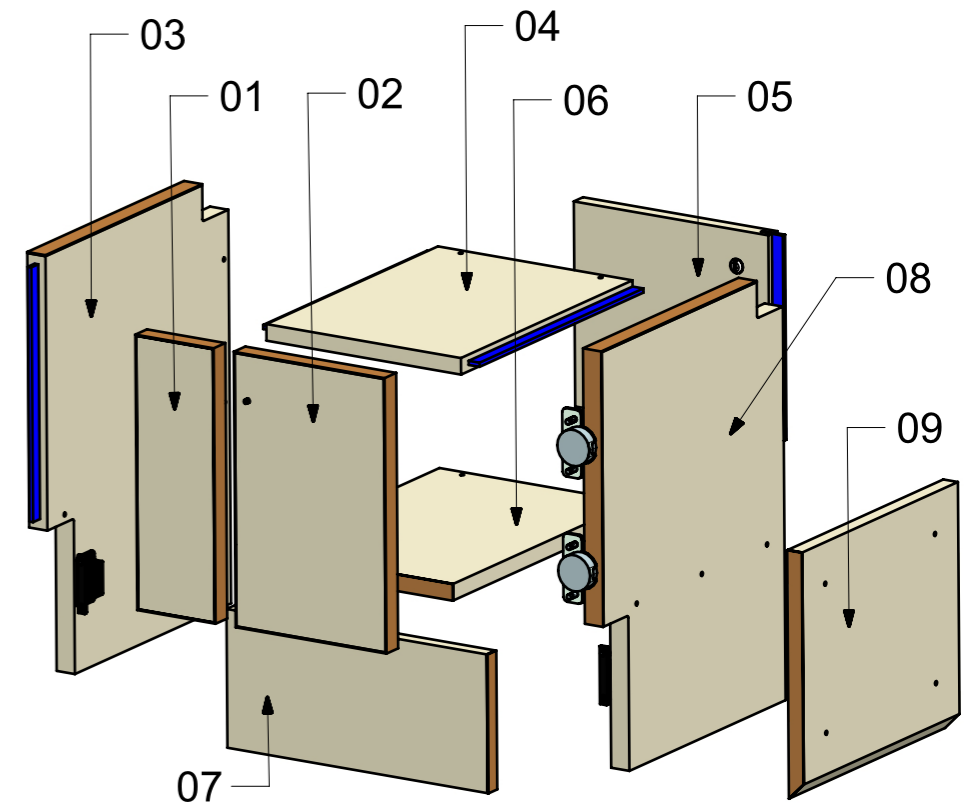
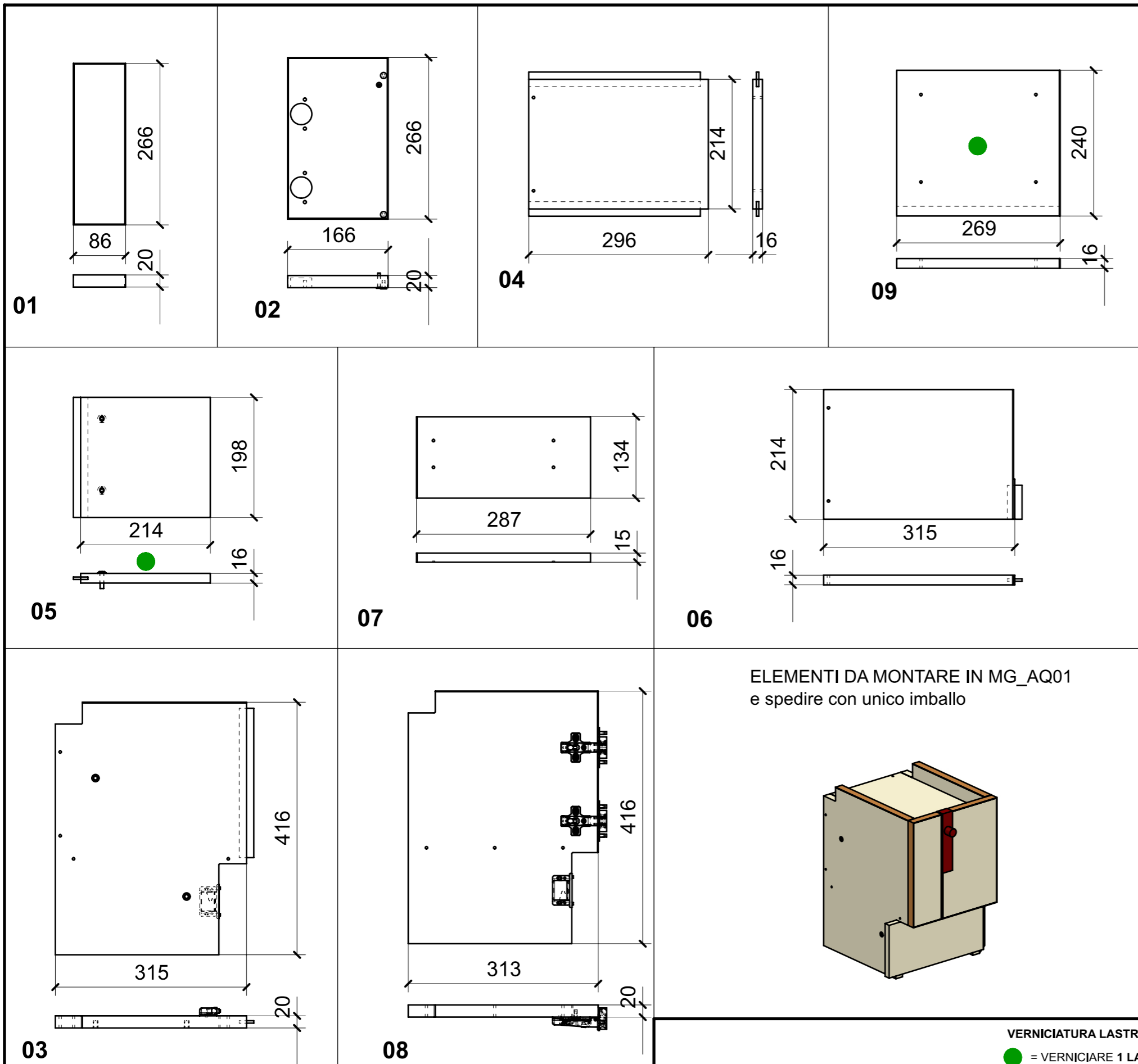

ELEMENTI DA MONTARE IN MG\_AQ01  
e spedire con unico imballo

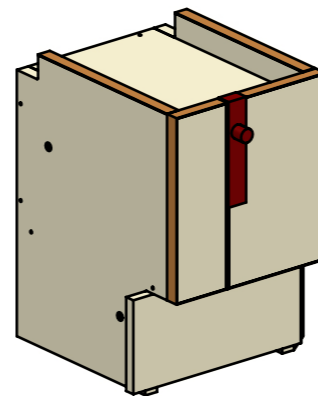

FERRAMENTA	QTY
BASE_0_HAFELE_329_84_020	2
BUSSOLA 5MA ANKOR BORGHI X BASE 0	4
BUSSOLA 5MA ANKOR BORGHI X CERNIERA PIANA	4
BUSSOLA 6MA X 10 FORO DIAM.8	2
CERNIERA 94° PIANA AMMORTIZZATA_HAFELE_329_49_310	2
CHIUSURA A SPINTA_TECHNOPARTNER_SOU C3-203	2
GOMMINO PARACOLPO ANTA	2
VITE 4MA X 25 TESTA SVASATA ESAGONALE NERA	1
VITE 4MAX8 ANKOR BORGHI X BASE 0	4
VITE 4MAX8 ANKOR BORGHI X CERNIERA PIANA	4
VITE 6MA X 25 TESTA BOMBATA	2

VERNICIATURA LASTRA/LACCATI:

● = VERNICIARE 1 LATO + FILI RASATI O BORDATI

NESSUN SIMBOLO = VERNICIARE 2 LATI + FILI RASATI O BORDATI

LOCALE	CODICE	DESCRIZIONE COMPONENTE	FINITURA	Q.TA
CABINA ARMATORE	MD299_MG_AR01	COMODINO DX_STD VAR 1		1

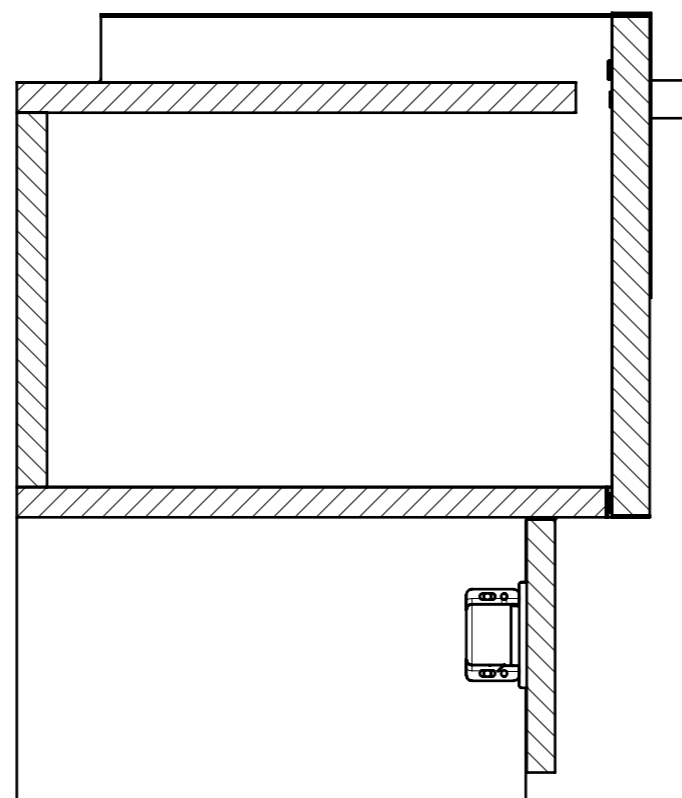
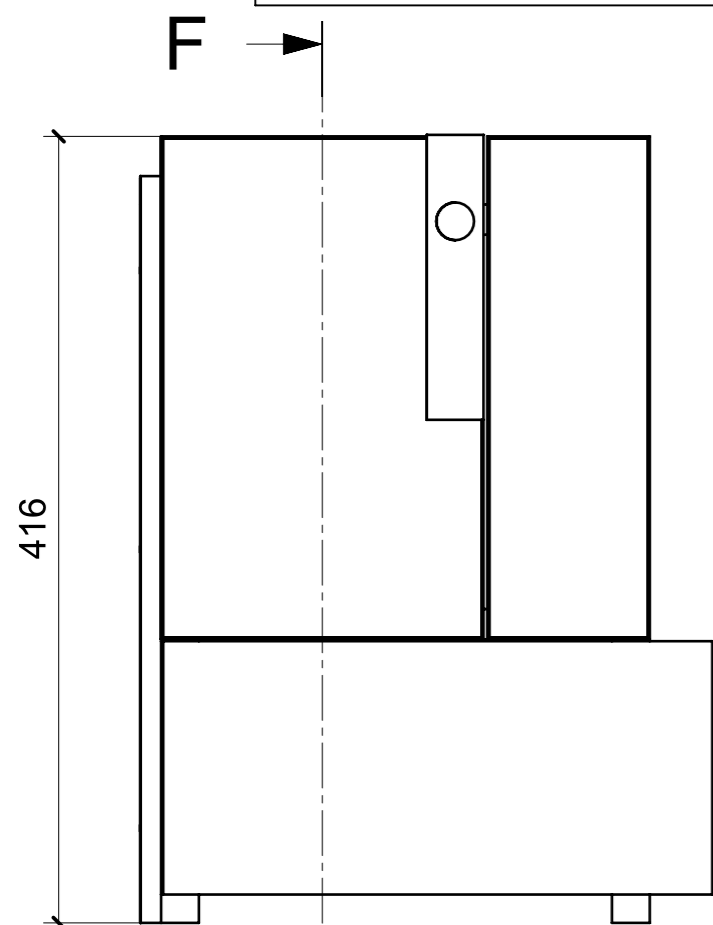

SECTION F-F

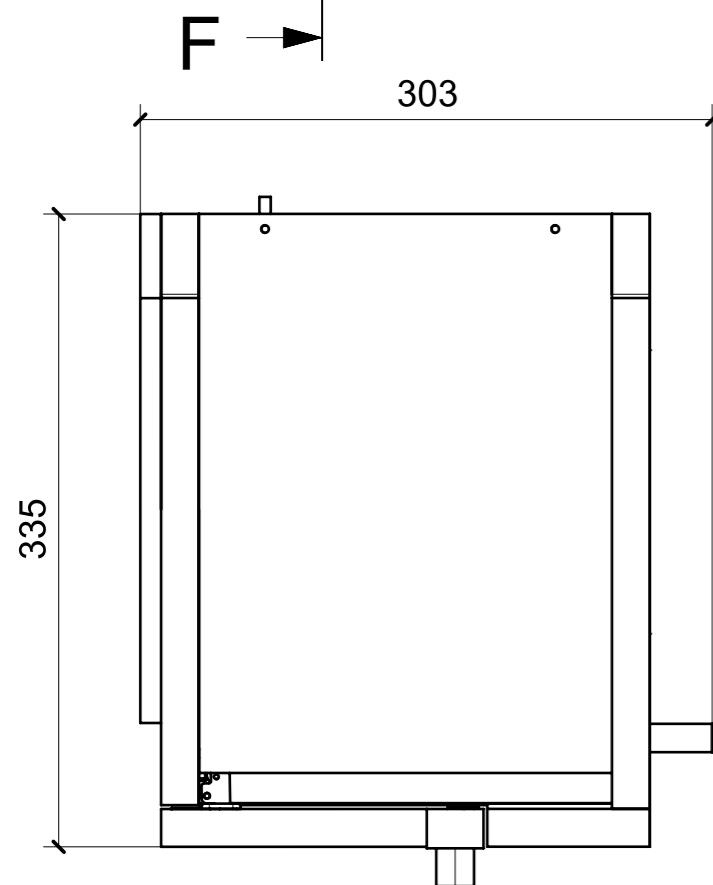
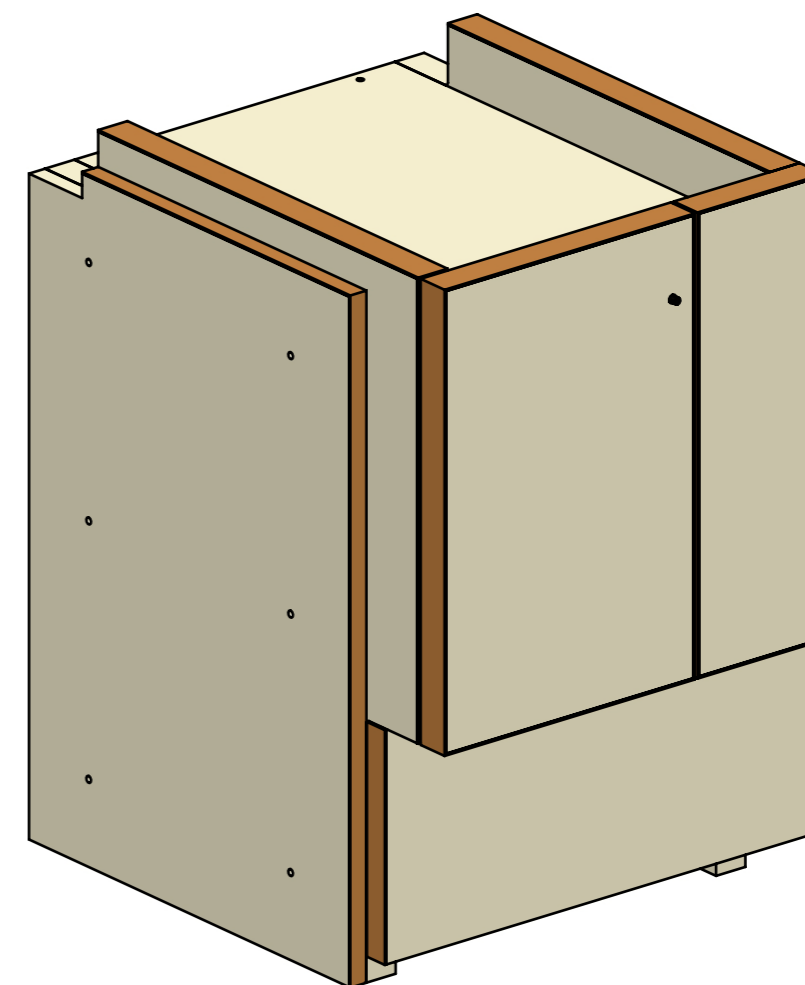

FERRAMENTA	QTY
BASE_0_HAFELE_329_84_020	2
BUSSOLA 5MA ANKOR BORGHI X BASE 0	4
BUSSOLA 5MA ANKOR BORGHI X CERNIERA PIANA	4
BUSSOLA 6MA X 10 FORO DIAM.8	2
CERNIERA 94° PIANA AMMORTIZZATA_HAFELE_329_49_310	2
CHIUSURA A SPINTA_TECHNOPARTNER_SOU C3-203	2
GOMMINO PARACOLPO ANTA	2
VITE 4MA X 25 TESTA SVASATA ESAGONALE NERA	1
VITE 4MAX8 ANKOR BORGHI X BASE 0	4
VITE 4MAX8 ANKOR BORGHI X CERNIERA PIANA	4
VITE 6MA X 25 TESTA BOMBATA	2

LOCALE	CODICE	DESCRIZIONE COMPONENTE	FINITURA	Q.TA
CABINA ARMATORE	MD299_R01_AR01	COMODINO DX_STD VAR 1	LASTRA SCURA	1

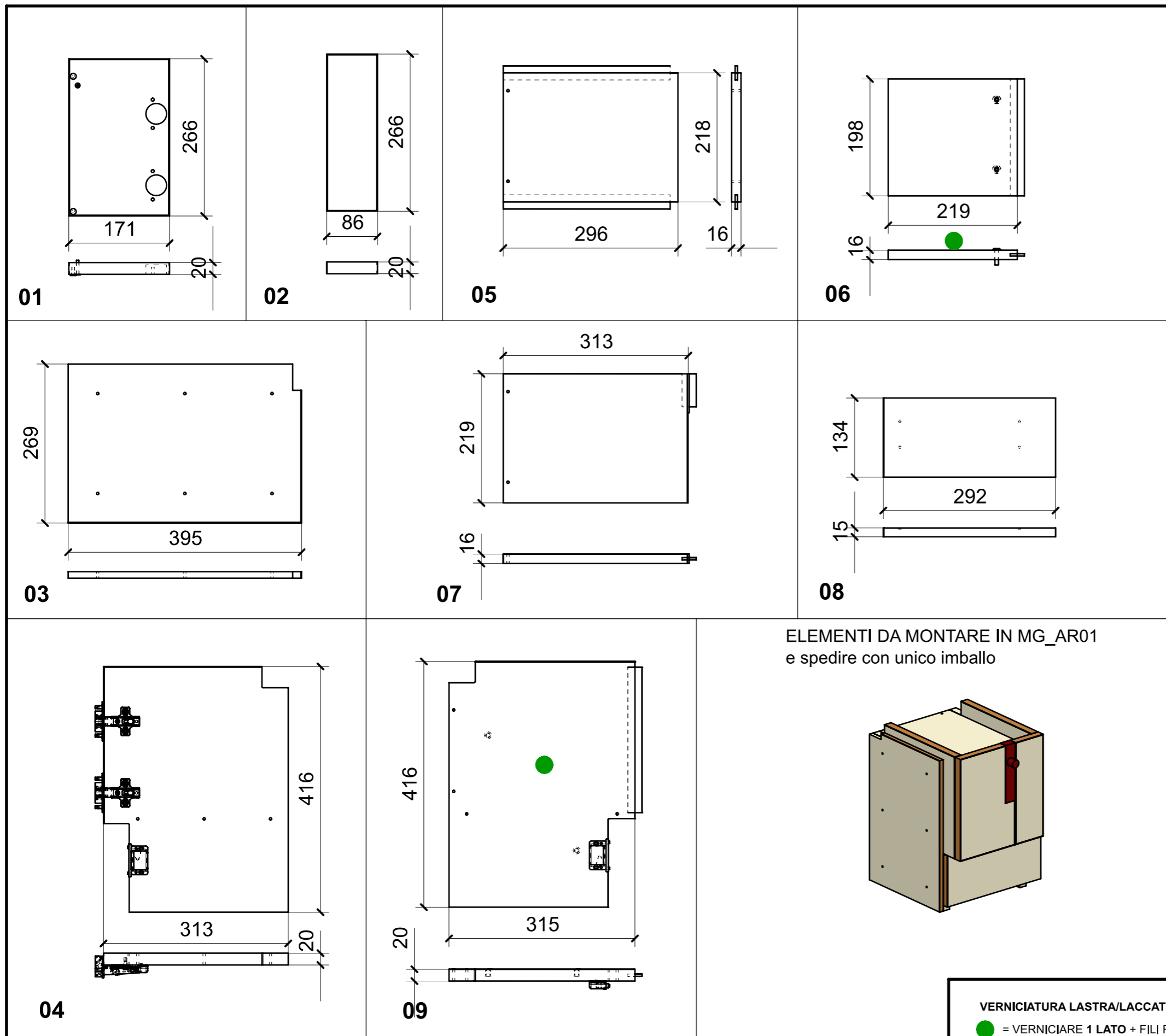

ELEMENTI DA MONTARE IN MG\_AR01  
e spedire con unico imballo

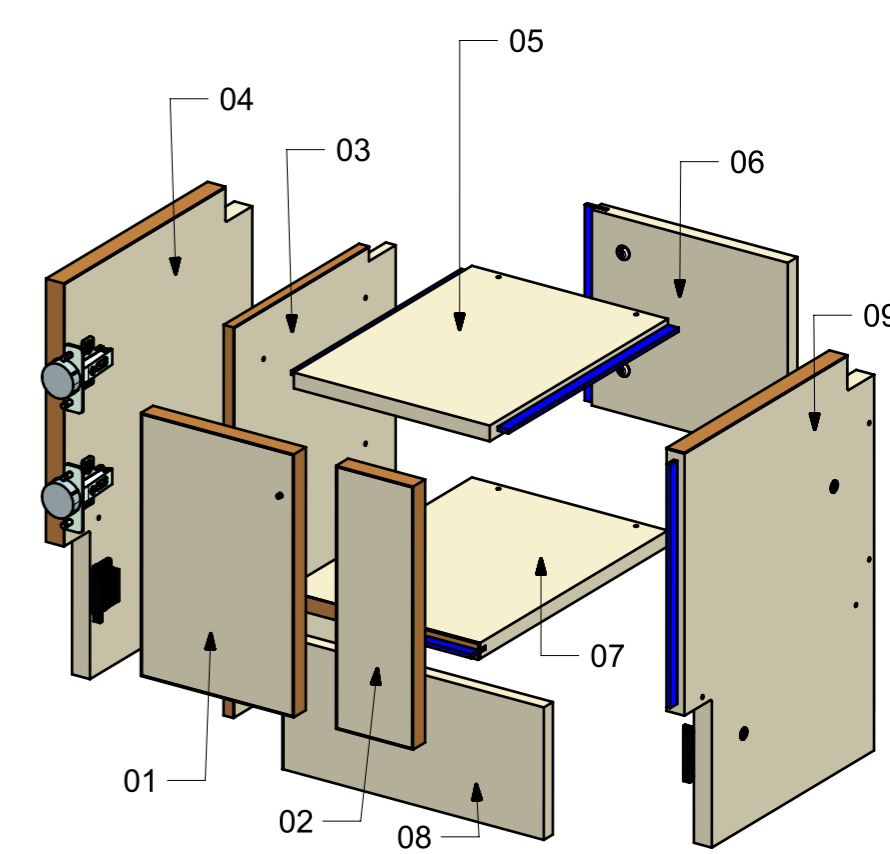
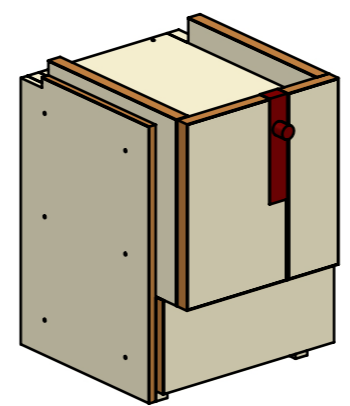

FERRAMENTA	QTY
BASE_0_HAFELE_329_84_020	2
BUSSOLA 5MA ANKOR BORGHI X BASE 0	4
BUSSOLA 5MA ANKOR BORGHI X CERNIERA PIANA	4
BUSSOLA 6MA X 10 FORO DIAM.8	2
CERNIERA 94° PIANA AMMORTIZZATA_HAFELE_329_49_310	2
CHIUSURA A SPINTA_TECHNOPARTNER_SOU C3-203	2
GOMMINO PARACOLPO ANTA	2
VITE 4MA X 25 TESTA SVASATA ESAGONALE NERA	1
VITE 4MAX8 ANKOR BORGHI X BASE 0	4
VITE 4MAX8 ANKOR BORGHI X CERNIERA PIANA	4
VITE 6MA X 25 TESTA BOMBATA	2

VERNICIATURA LASTRA/LACCATI:  
● = VERNICIARE 1 LATO + FILI RASATI O BORDATI      NESSUN SIMBOLO = VERNICIARE 2 LATI + FILI RASATI O BORDATI

LOCALE	CODICE	DESCRIZIONE COMPONENTE	FINITURA	Q.TA
CABINA ARMATORE	MD299_MF_AS01	CIELINO		1

MD299\_MF\_AS02

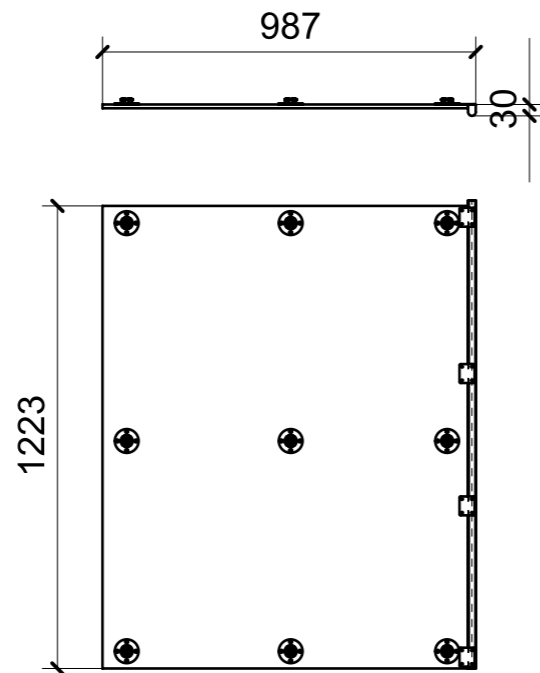
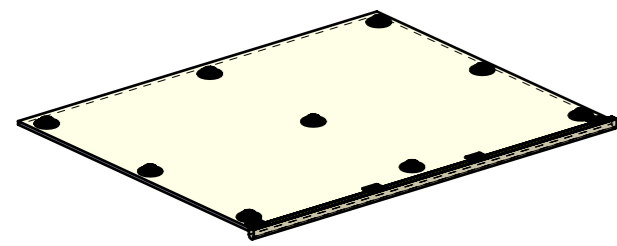

02

MD299\_MF\_AS01

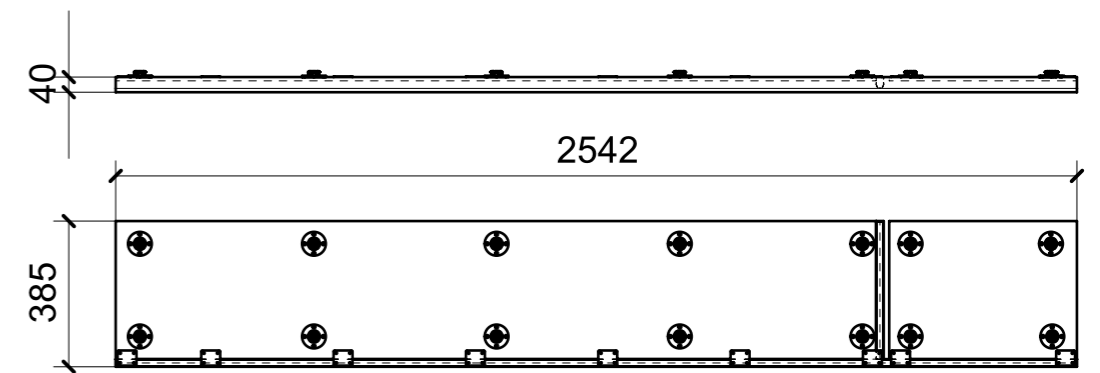
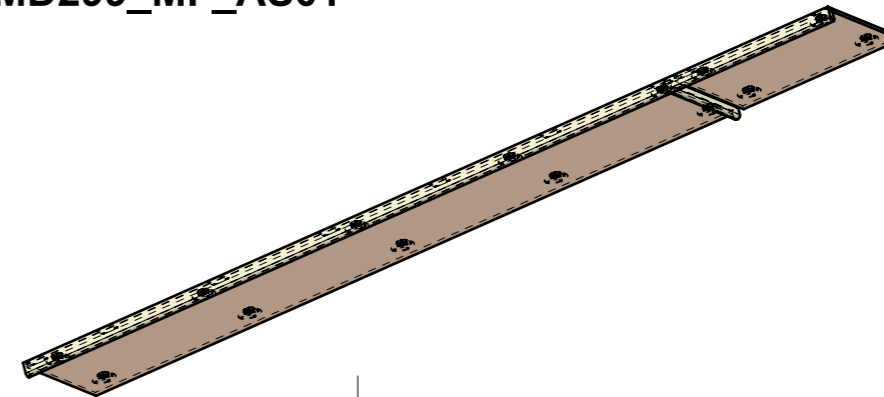

01

MD299\_MF\_AS03

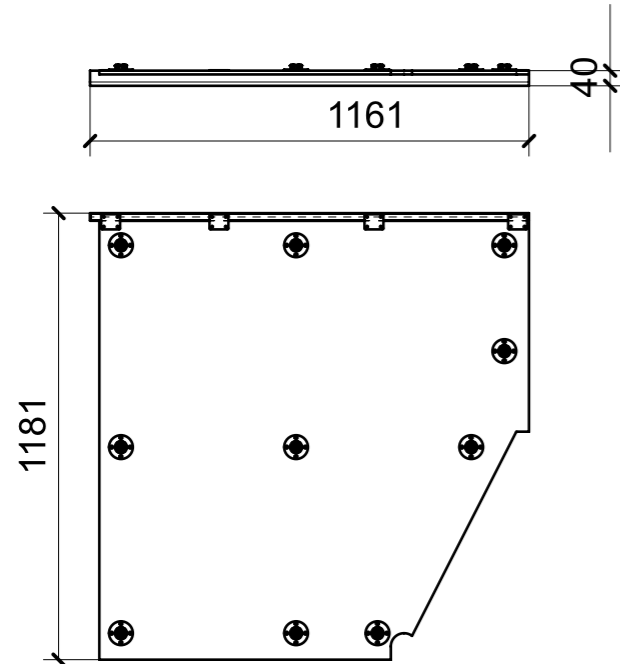
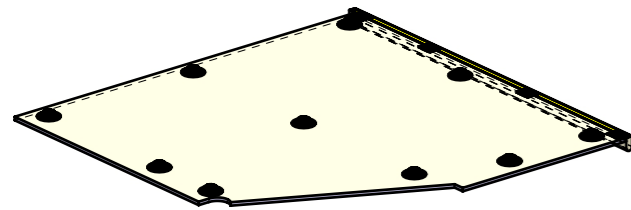

03

MD299\_MF\_AS04

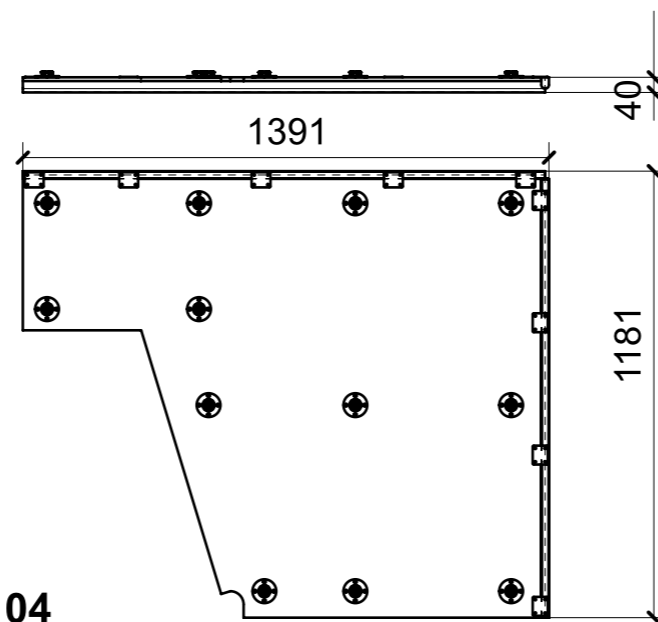
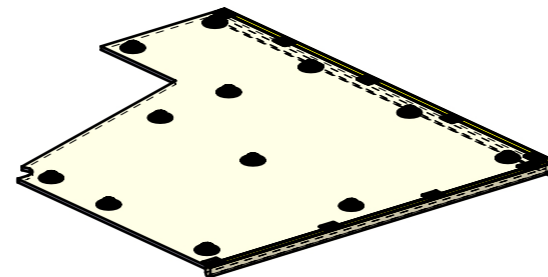

04

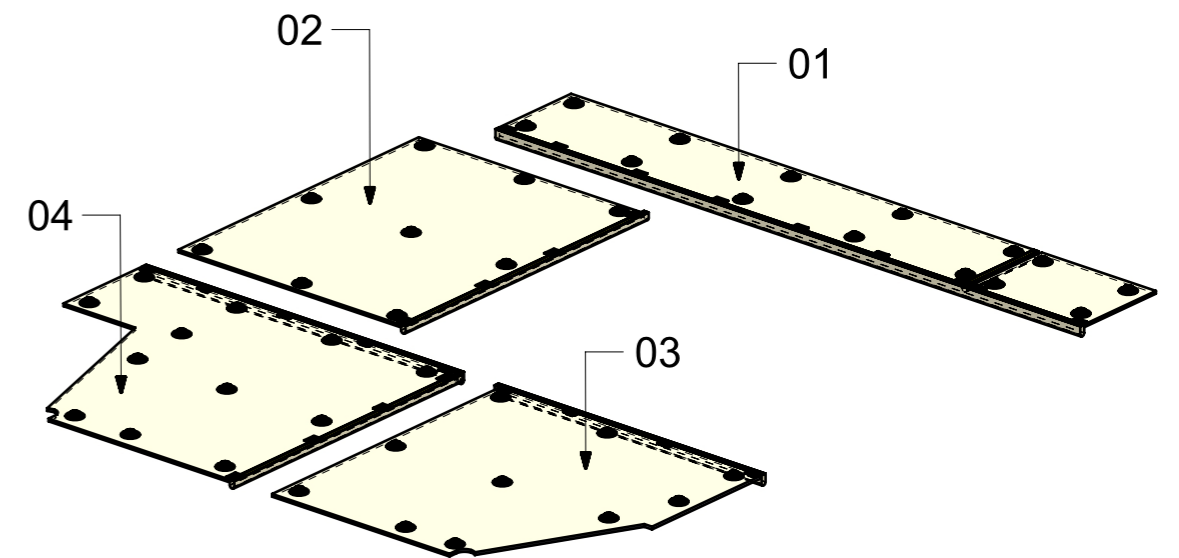

LOCALE	CODICE	DESCRIZIONE COMPONENTE	FINITURA	Q.TA
CABINA ARMATORE	MD299_R01_AS01	CIELINO	LASTRA SCURA	1

05

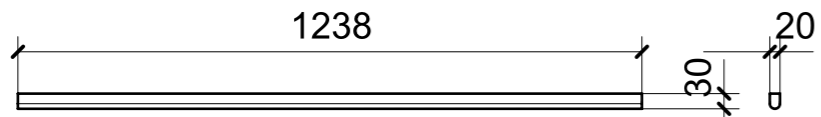

ELEMENTO DA MONTARE CON L01\_03 IN MF\_AS02  
e spedire con unico imballo

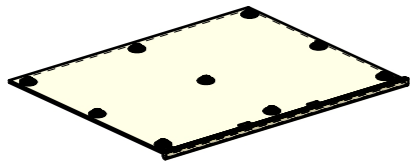

ELEMENTI DA MONTARE CON L01\_01/02 IN MF\_AS01  
e spedire con unico imballo

02

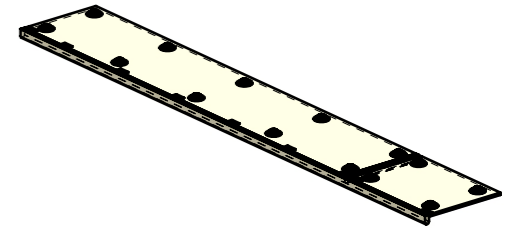
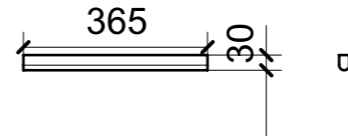

03

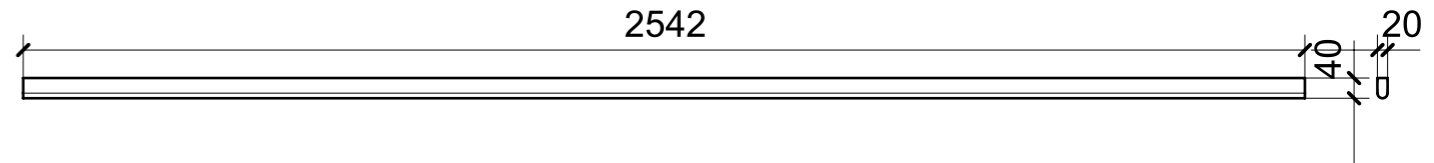

06

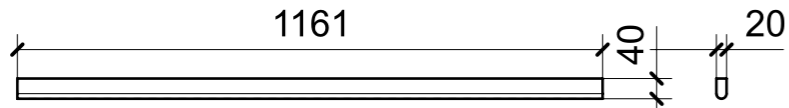

ELEMENTO DA MONTARE CON R01\_06 IN MF\_AS03  
e spedire con unico imballo

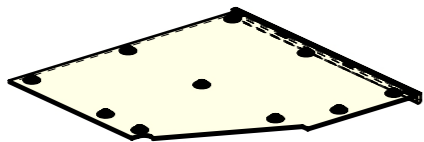

01

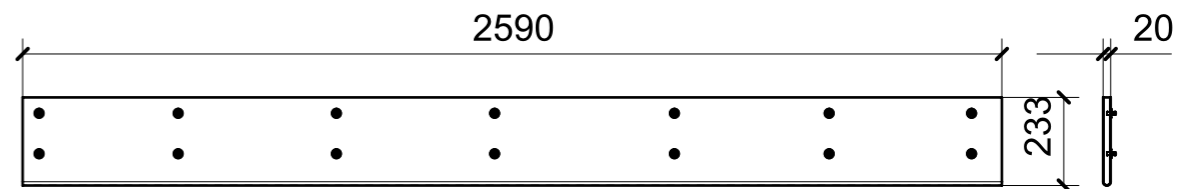

07

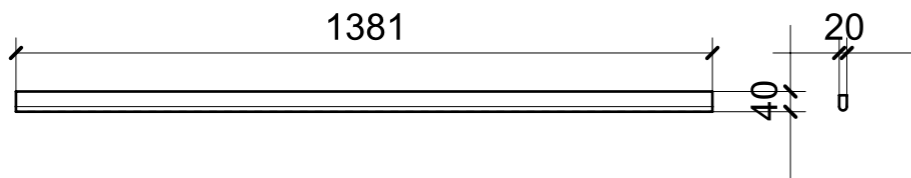

08

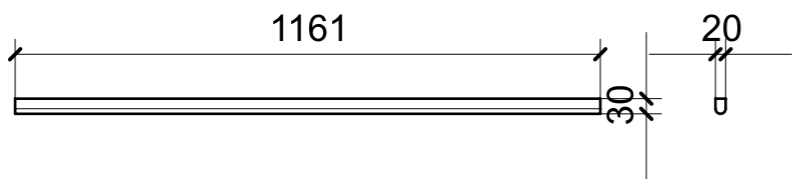

ELEMENTI DA MONTARE CON L01\_05 IN MF\_AS04  
e spedire con unico imballo

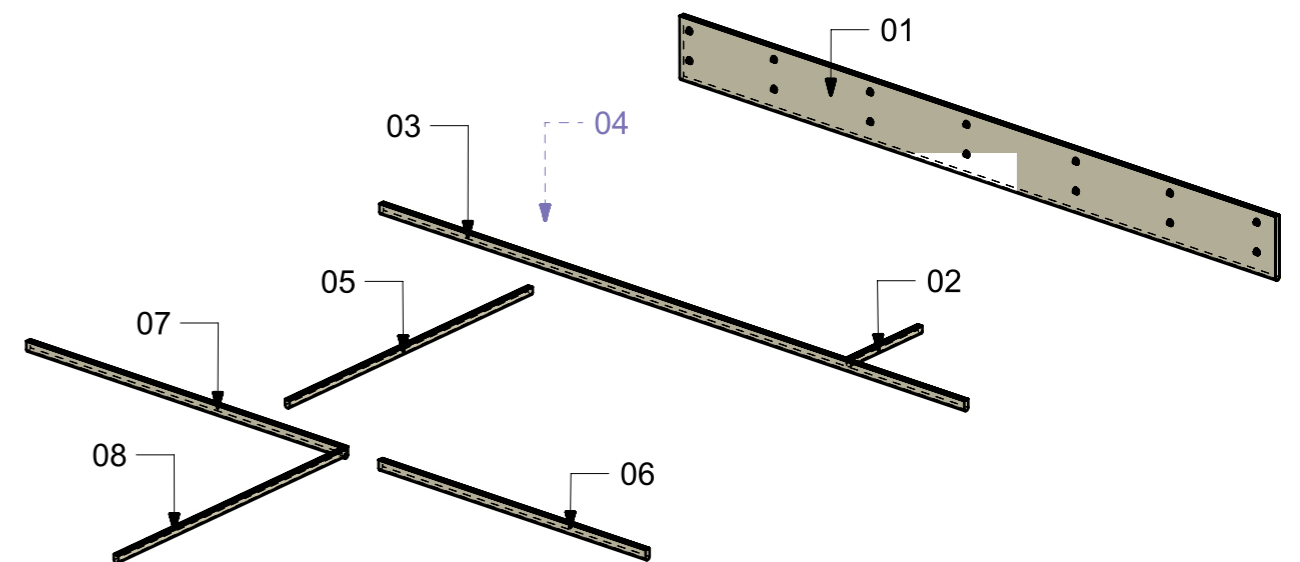
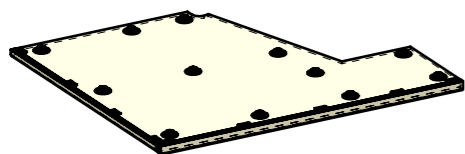

FERRAMENTA	QTY
MS INCASSO_ITALVIPLA_972_FMPC_M1B	14

VERNICIATURA LASTRA/LACCATI:

● = VERNICIARE 1 LATO + FILI RASATI O BORDATI

NESSUN SIMBOLO = VERNICIARE 2 LATI + FILI RASATI O BORDATI

LOCALE	CODICE	DESCRIZIONE COMPONENTE	FINITURA	Q.TA
CABINA ARMATORE	MD299_L01_AS01	CIELINO	LACCATO BIANCO 9010	1

**03**

ELEMENTO DA MONTARE CON R01\_05 IN MF\_AS02  
e spedire con unico imballo

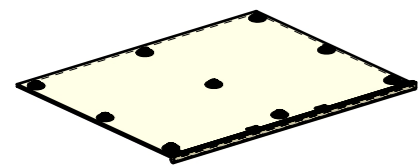

**05**

ELEMENTO DA MONTARE CON R01\_07/08 IN MF\_AS04  
e spedire con unico imballo

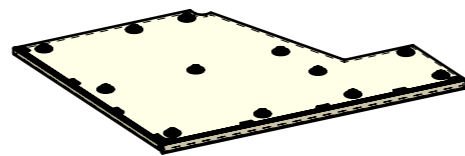

**06**

ELEMENTO DA MONTARE CON R01\_06 IN MF\_AS03  
e spedire con unico imballo

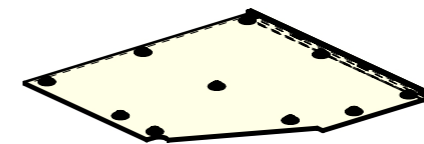

**04**

**01**

ELEMENTI DA MONTARE CON R01\_02/03/04 IN MF\_AS01  
e spedire con unico imballo

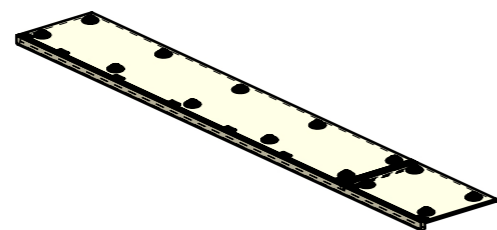

**02**

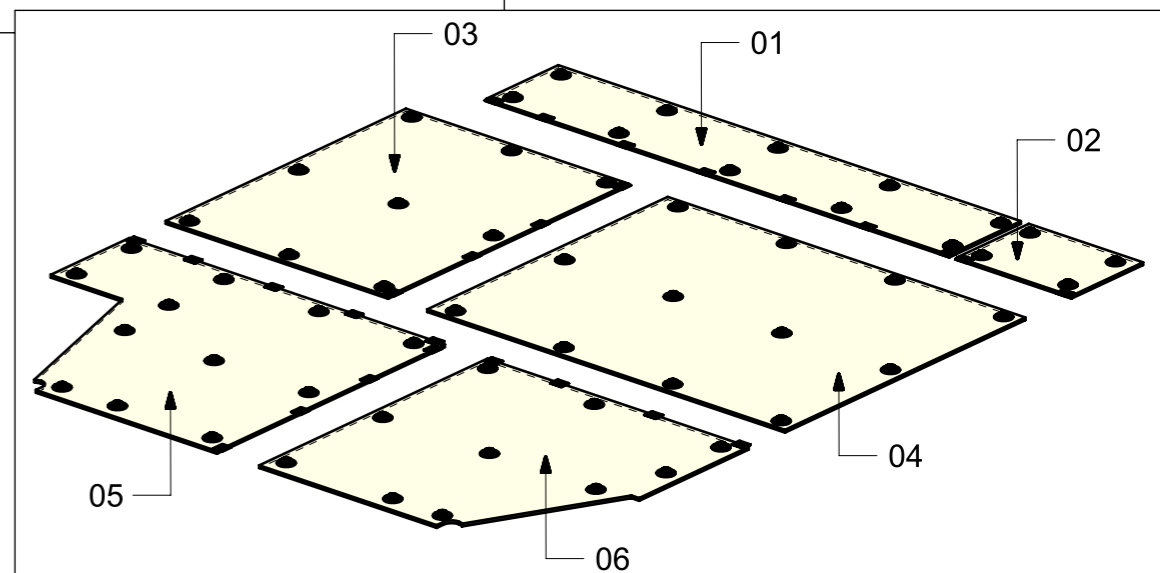

FERRAMENTA	QTY
FITLOCK M_MASCHERPA_3MM_6020202101	57
PIASTRINA SP.1MM 50X40_FBC_ART_264 Z	26

VERNICIATURA LASTRA/LACCATI:

● FILI RASATI

● = VERNICIARE 1 LATO + FILI RASATI O BORDATI

NESSUN SIMBOLO = VERNICIARE 2 LATI + FILI RASATI O BORDATI

LOCALE	CODICE	DESCRIZIONE COMPONENTE	FINITURA	Q.TA
CABINA ARMATORE	MD299_MF_AU01	ANTE MOBILE MURATA_STD VAR 2 VERDE 100 GLOSS		1

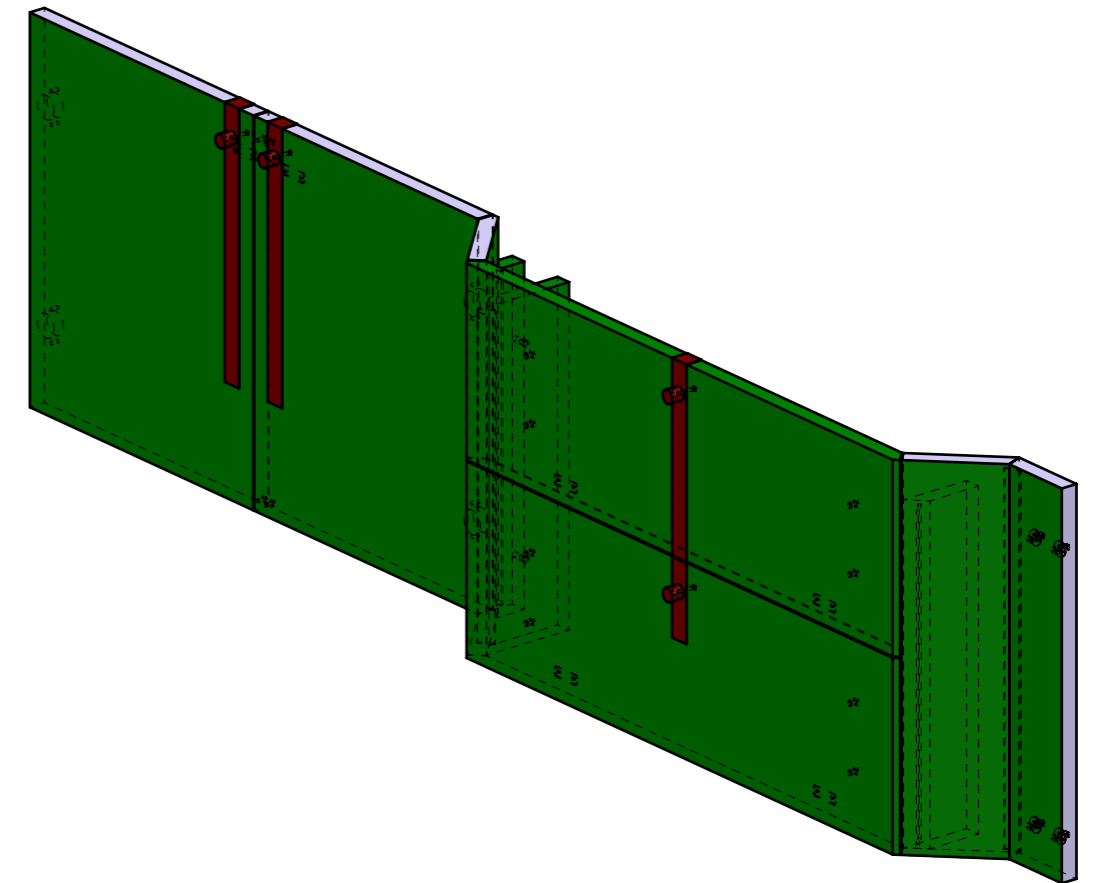
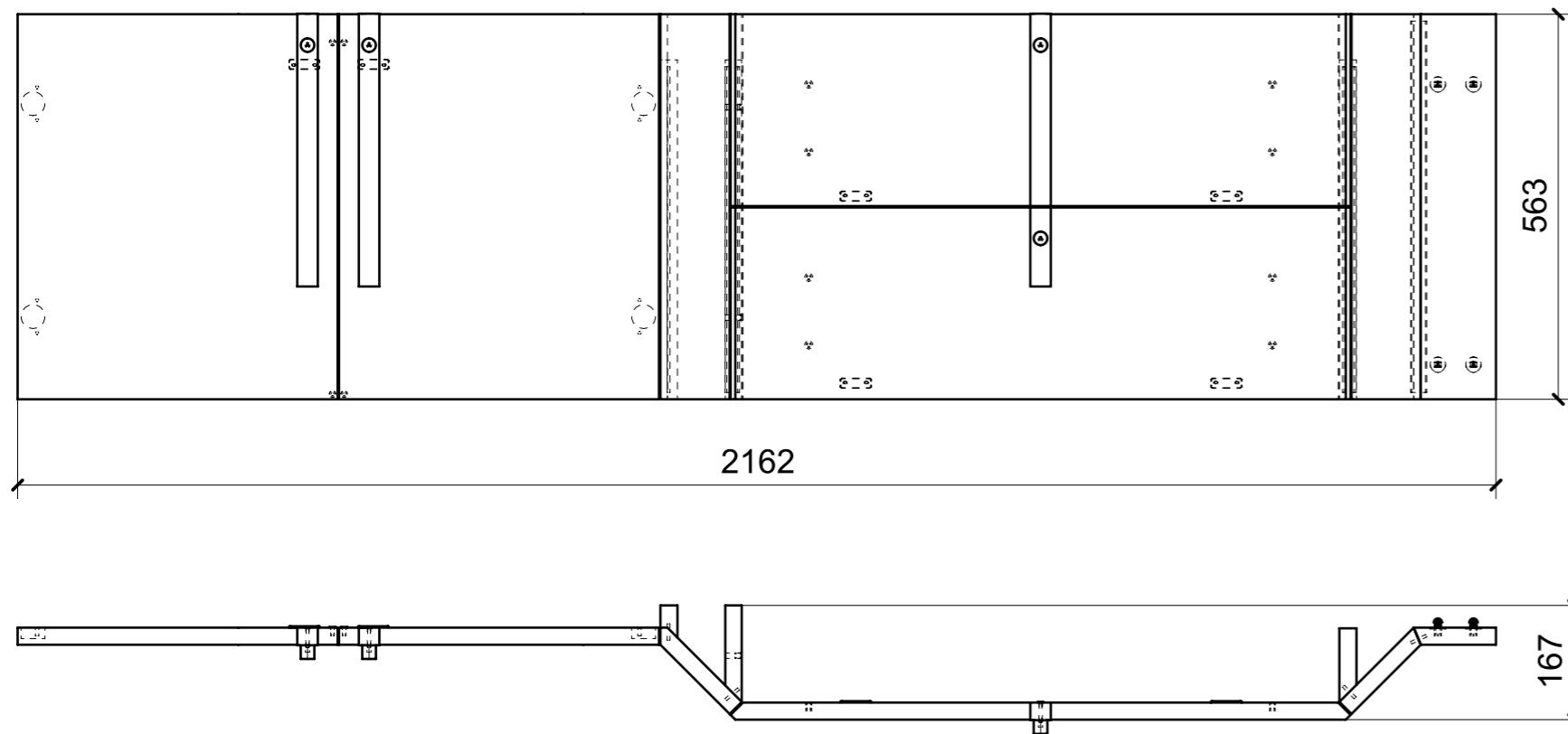

FERRAMENTA	QTY
BUSSOLA 5MA X 10 FORO DIAM.8	8
BUSSOLA 6MA X 10 FORO DIAM.8	2
GOMMINO PARACOLPO ANTA	4
MS INCASSO_ITALVIPLA_972_FMPC_M1B	4
PLACCHETTA COUNTER STEEL_TECHNOPARTNER_MC-JM49	6
VITE 4MA X 30 TESTA SVASATA ESAGONALE NERA	4

LOCALE	CODICE	DESCRIZIONE COMPONENTE	FINITURA	Q.TA
CABINA ARMATORE	MD299_L01_AU01	ANTE MOBILE MURATA_STD VAR 2 VERDE 100 GLOSS	LACCATO VERDE NCS S 5020 B70G LUCIDO 100 gloss	1

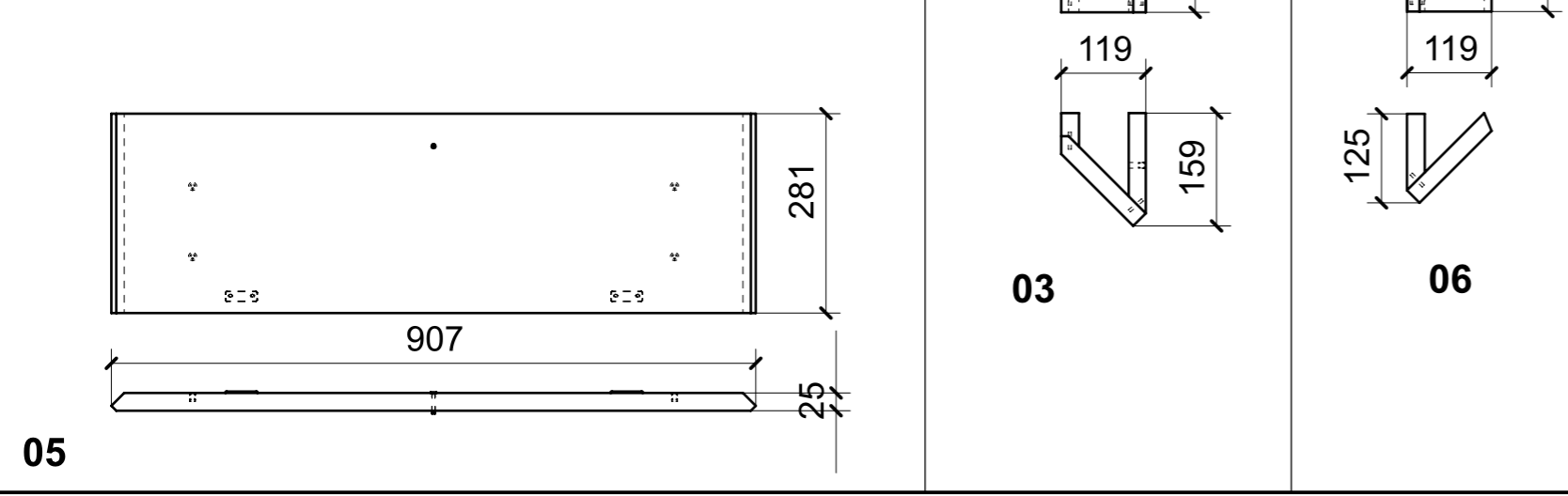
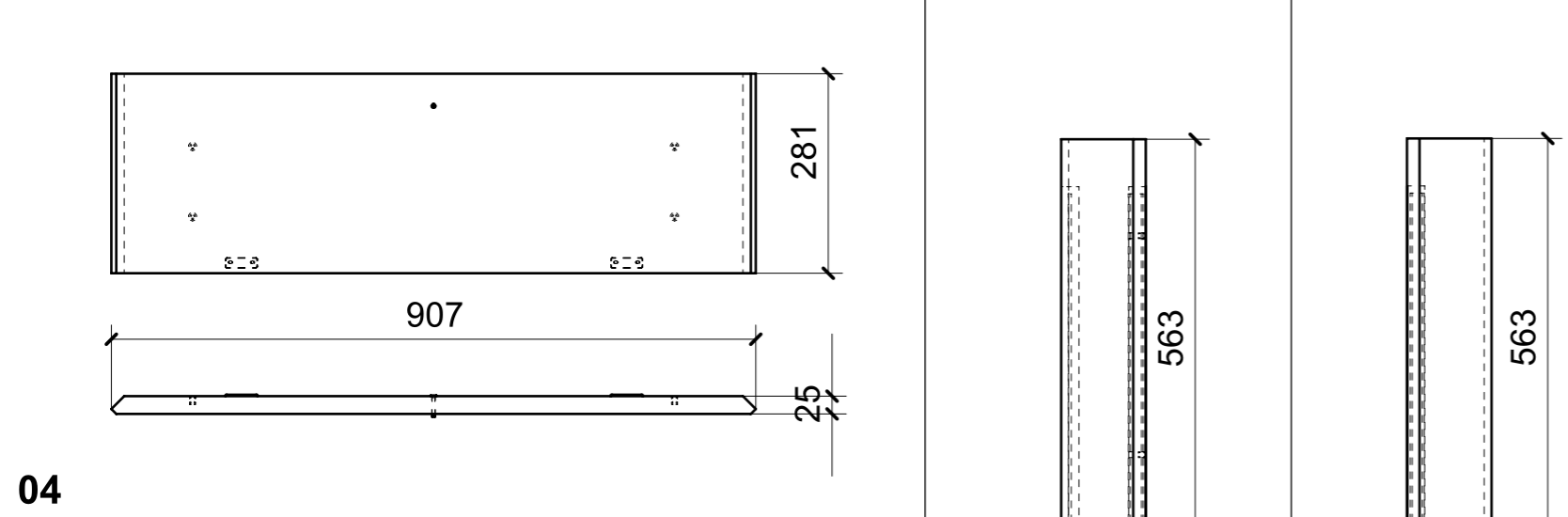
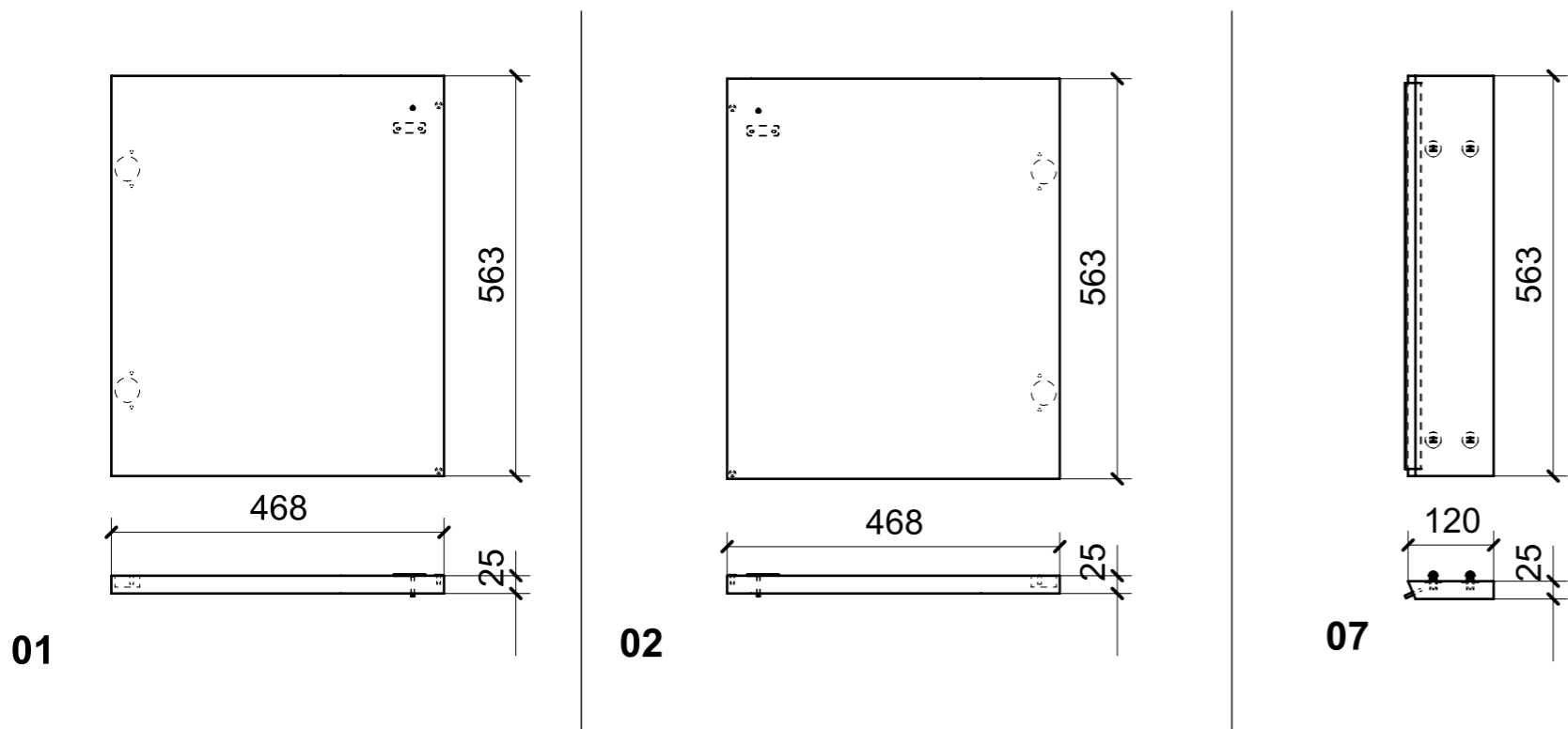

ELEMENTI DA MONTARE CON A10/A11/A12/A22 IN MF\_AU01  
e spedire con unico imballo

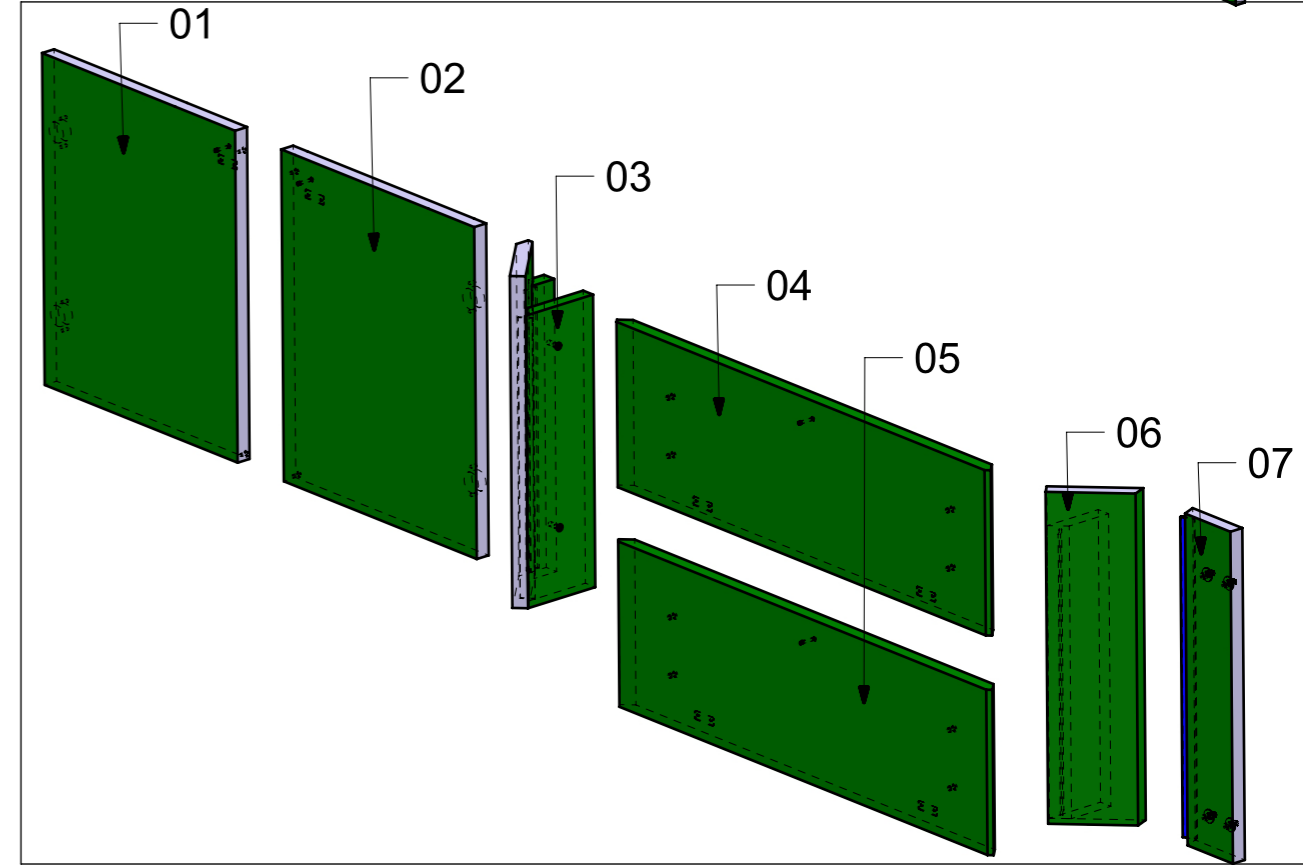
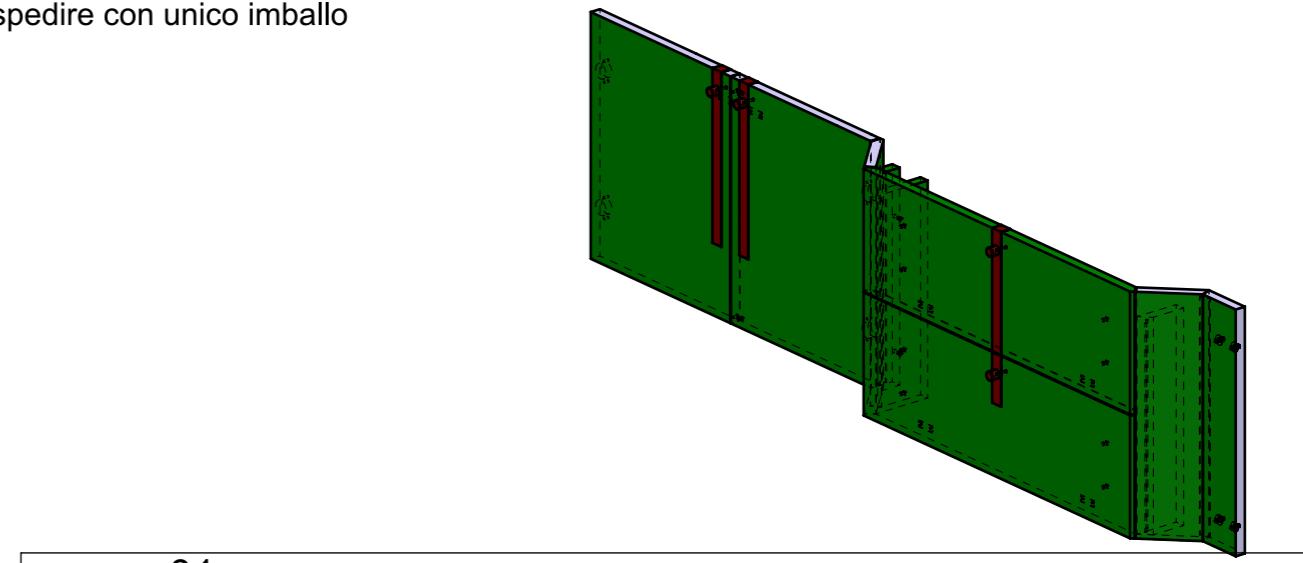

FERRAMENTA	QTY
BUSSOLA 5MA X 10 FORO DIAM.8	8
BUSSOLA 6MA X 10 FORO DIAM.8	2
GOMMINO PARACOLPO ANTA	4
MS INCASSO_ITALVIPLA_972_FMPC_M1B	4
PLACCHETTA COUNTER STEEL_TECHNOPARTNER_MC-JM49	6
VITE 4MA X 30 TESTA SVASATA ESAGONALE NERA	4

VERNICIATURA LASTRA/LACCATI:  
● = VERNICIARE 1 LATO + FILI RASATI O BORDATI      NESSUN SIMBOLO = VERNICIARE 2 LATI + FILI RASATI O BORDATI

LOCALE	CODICE	DESCRIZIONE COMPONENTE	FINITURA	Q.TA
CABINA ARMATORE	MD299_A01_AU01	ANTE MOBILE MURATA_STD VAR 2 VERDE 100 GLOSS	ACCIAIO SATINATO BRONZO AUDREY	1

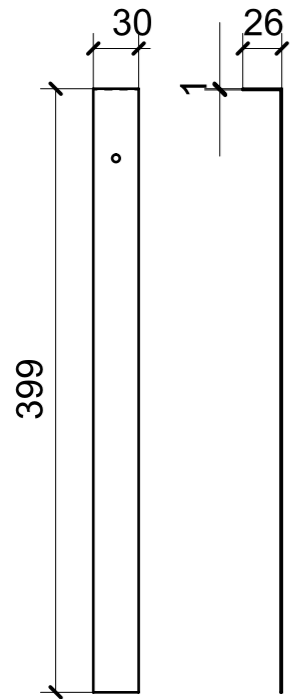

A10\_01

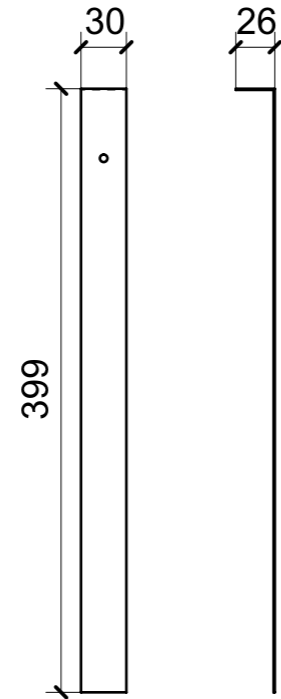

A10\_02

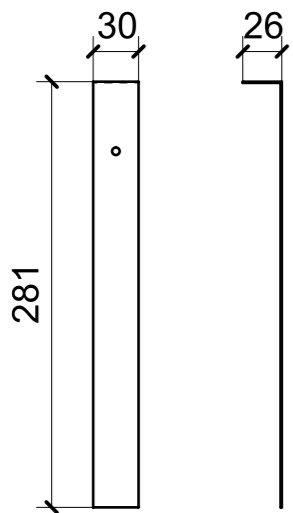

A11\_01

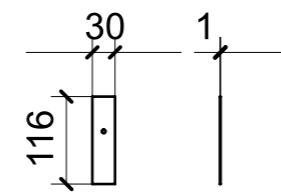

A12\_01

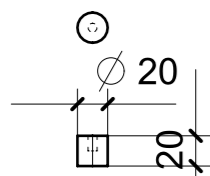

A22\_01

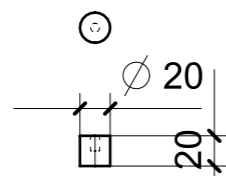

A22\_02

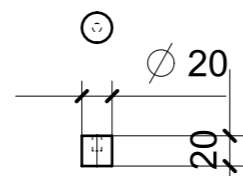

A22\_03

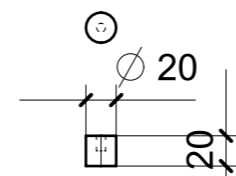

A22\_04

ELEMENTI DA MONTARE CON L01\_01/07 IN MF\_AU01  
e spedire con unico imballo

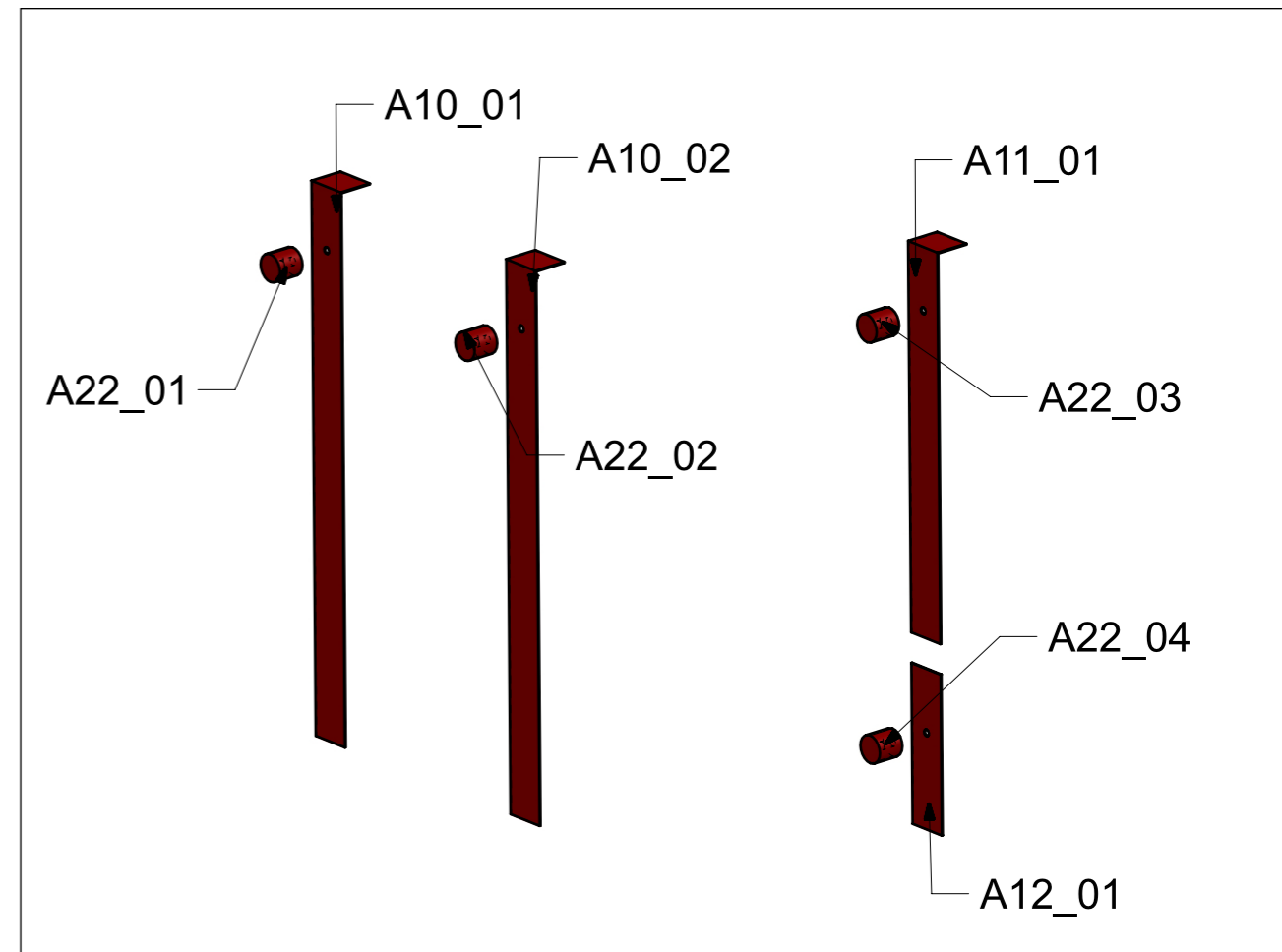
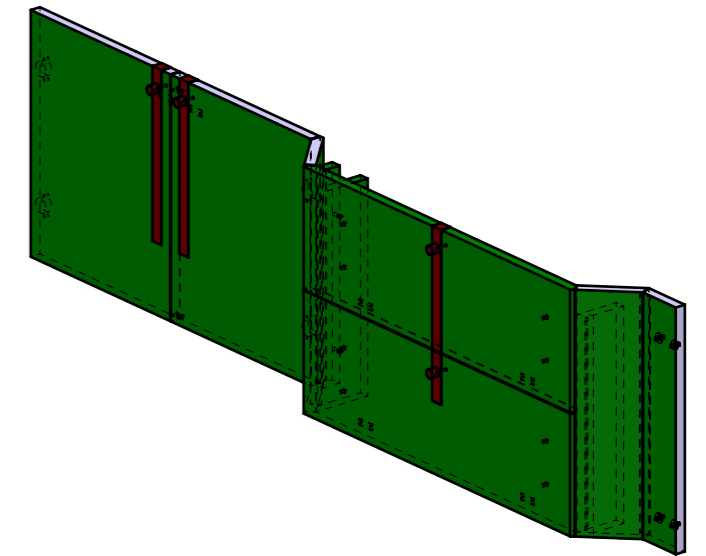

LOCALE	CODICE	DESCRIZIONE COMPONENTE	FINITURA	Q.TA
CABINA ARMATORE	MD299_MF01_AV01	ANTE MOBILE MURATA_STD VAR 1 AZZURRO\GRIGIO 100 GLOSS		1

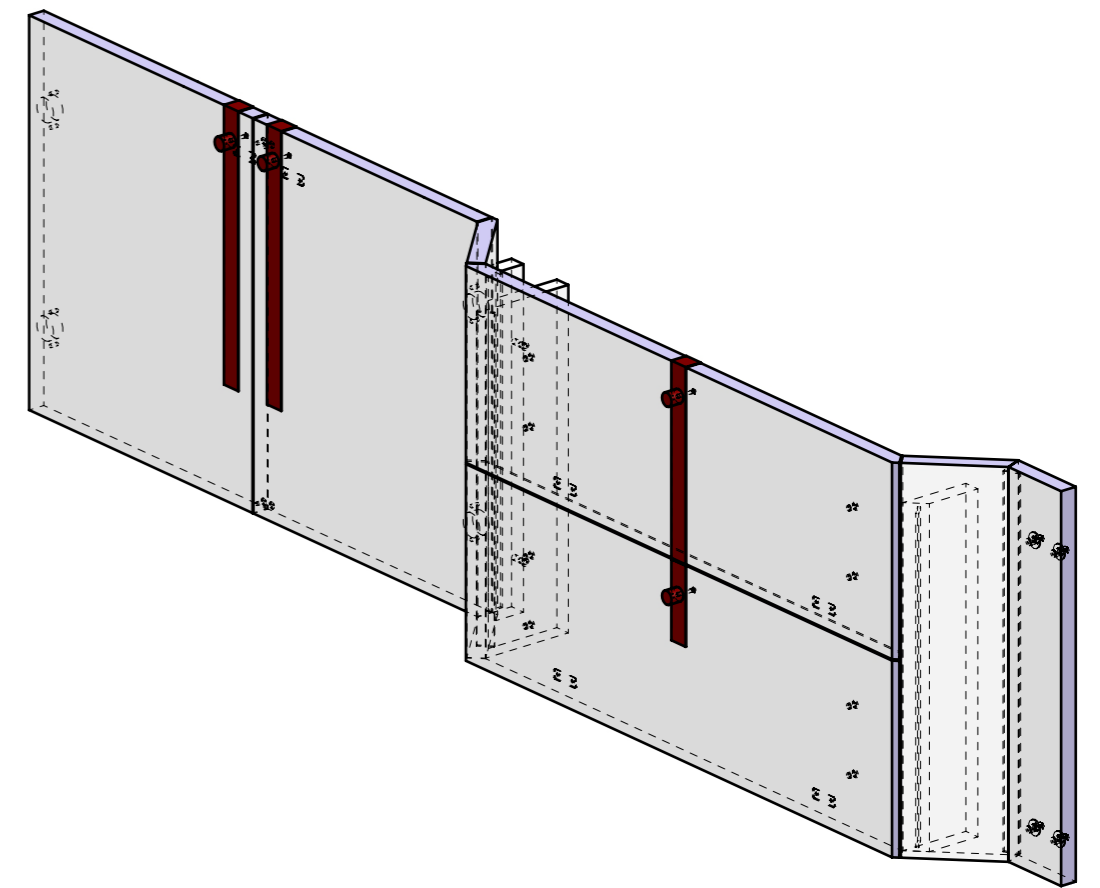
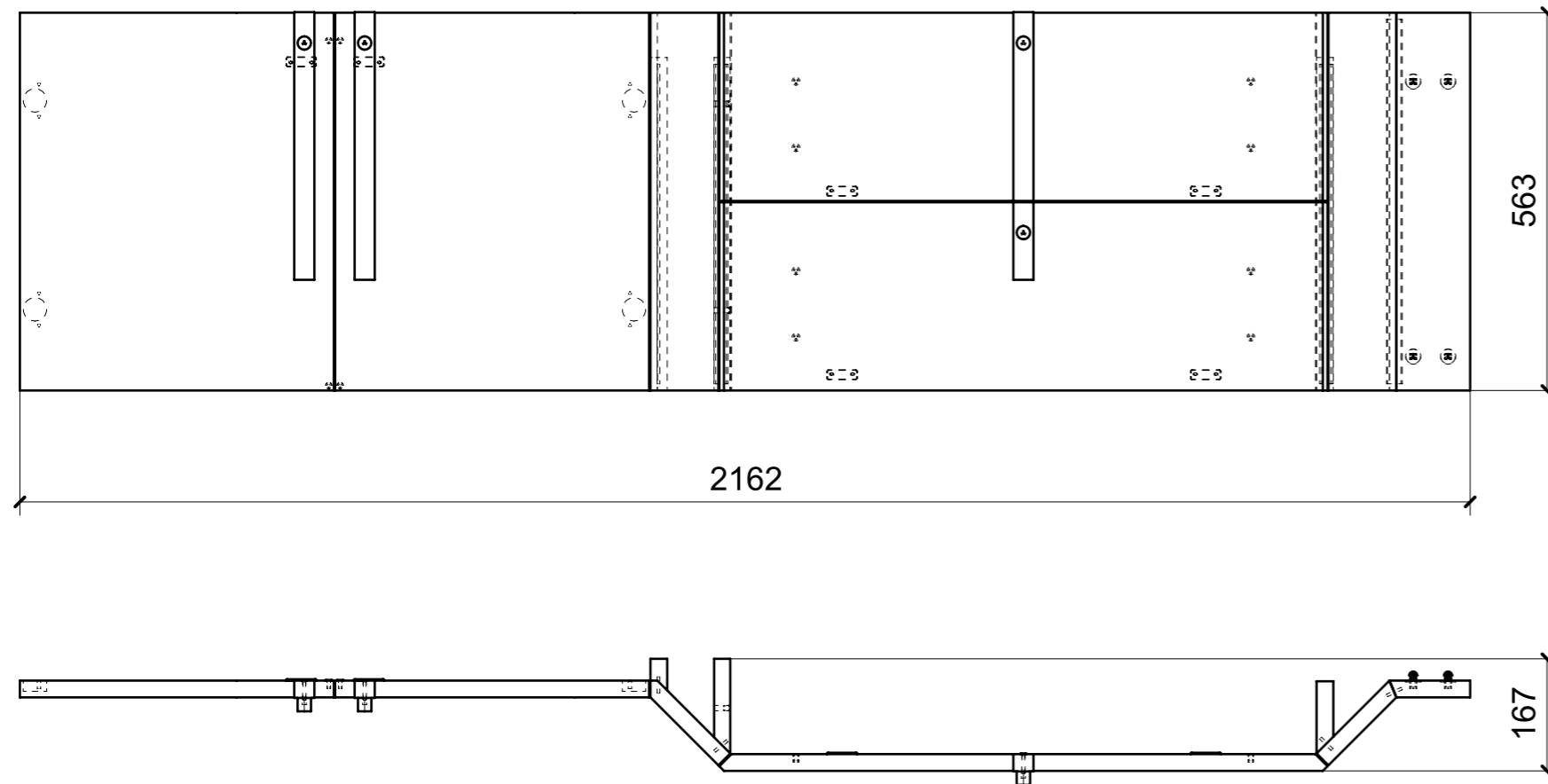

FERRAMENTA	QTY
BUSSOLA 5MA X 10 FORO DIAM.8	8
BUSSOLA 6MA X 10 FORO DIAM.8	2
GOMMINO PARACOLPO ANTA	4
MS INCASSO_ITALVIPLA_972_FMPC_M1B	4
PLACCHETTA COUNTER STEEL_TECHNOPARTNER_MC-JM49	6
VITE 4MA X 30 TESTA SVASATA ESAGONALE NERA	8

LOCALE	CODICE	DESCRIZIONE COMPONENTE	FINITURA	Q.TA
CABINA ARMATORE	MD299_L01_AV01	ANTE MOBILE MURATA_STD VAR 1 AZZURRO\GRIGIO 100 GLOSS	LACCATO AZZURRO\GRIGIO NCS S 3005 B 80 G 100 gloss	1

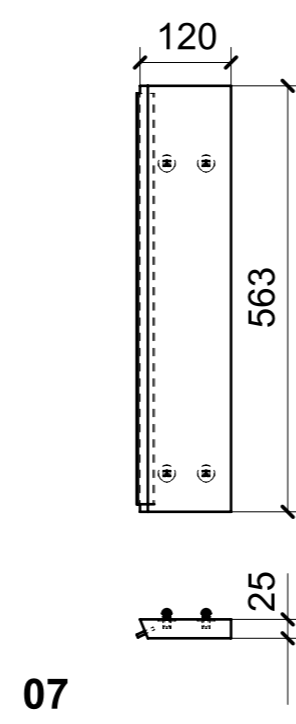
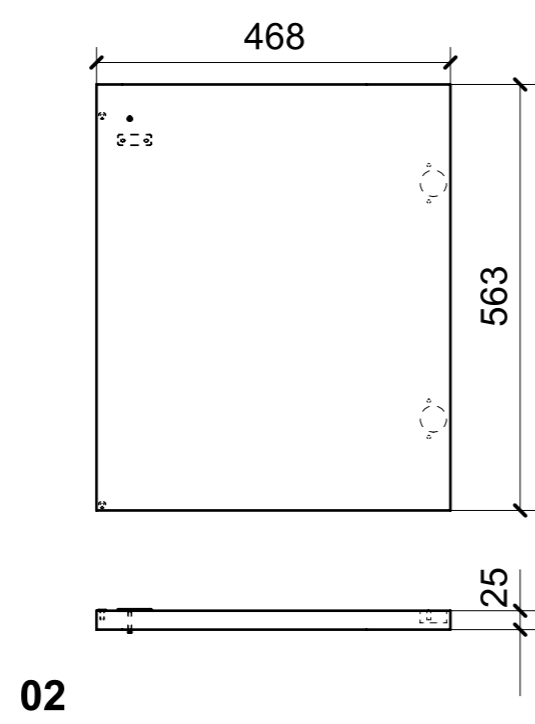
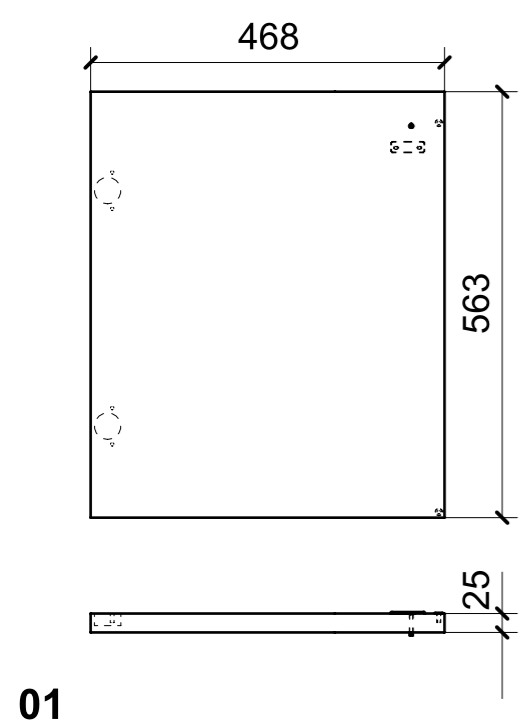

ELEMENTI DA MONTARE CON A10/A11/A12/A22 IN MF\_AV01  
e spedire con unico imballo

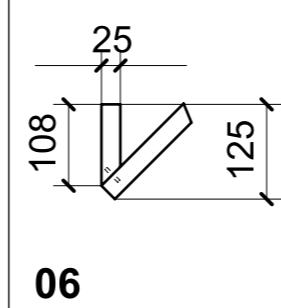
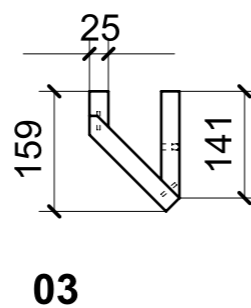
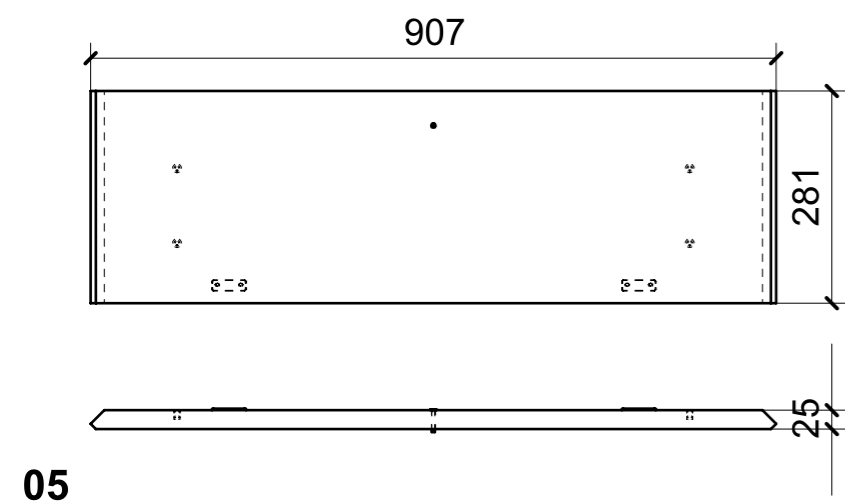
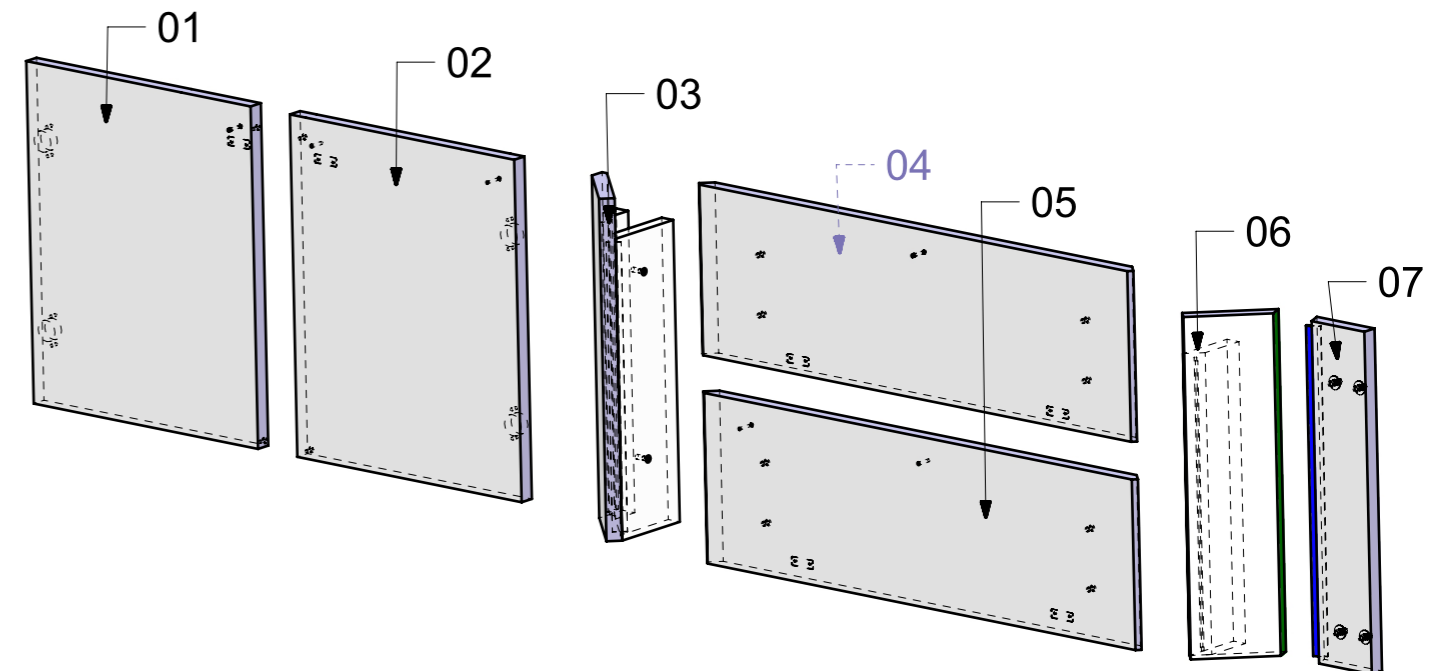
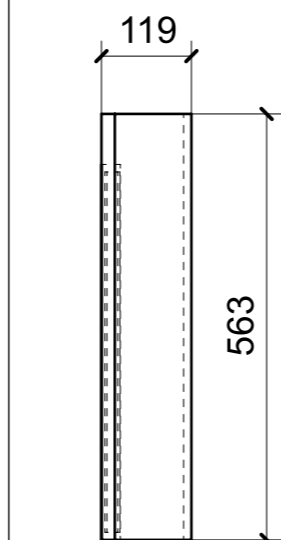
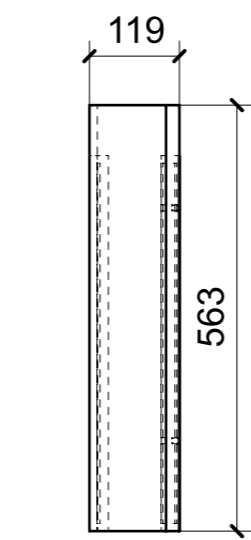
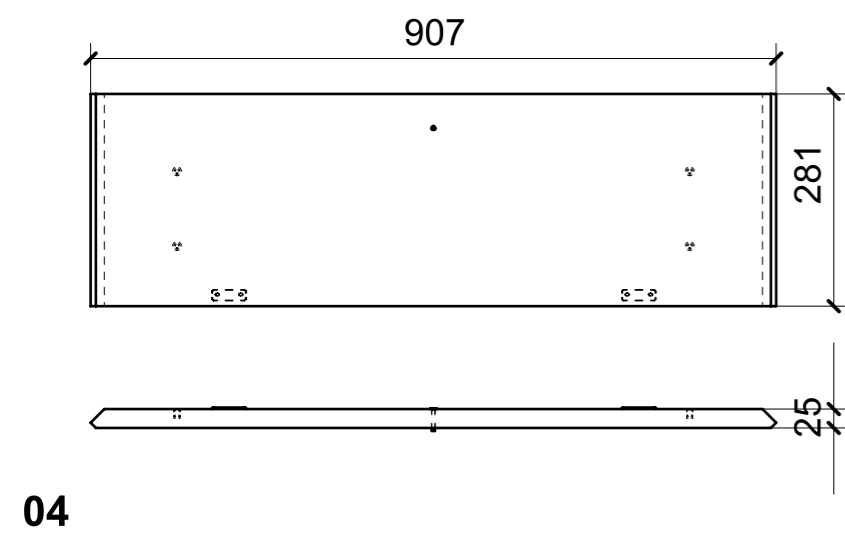
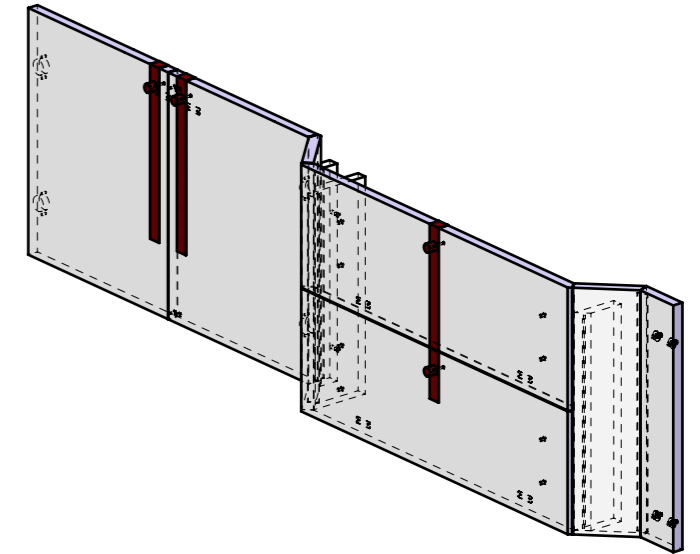

FERRAMENTA	QTY
BUSSOLA 5MA X 10 FORO DIAM.8	8
BUSSOLA 6MA X 10 FORO DIAM.8	2
GOMMINO PARACOLPO ANTA	4
MS INCASSO_ITALVIPLA_972_FMPC_M1B	4
PLACCHETTA COUNTER STEEL_TECHNOPARTNER_MC-JM49	6
VITE 4MA X 30 TESTA SVASATA ESAGONALE NERA	8

VERNICIATURA LASTRA/LACCATI:

● = VERNICIARE 1 LATO + FILI RASATI O BORDATI

NESSUN SIMBOLO = VERNICIARE 2 LATI + FILI RASATI O BORDATI

LOCALE	CODICE	DESCRIZIONE COMPONENTE	FINITURA	Q.TA
CABINA ARMATORE	MD299_A01_AV01	ANTE MOBILE MURATA_STD VAR 1 AZZURRO\GRIGIO 100 GLOSS	ACCIAIO SATINATO BRONZO AUDREY	1

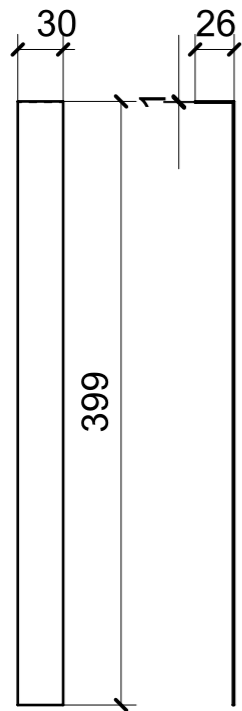

A10\_01

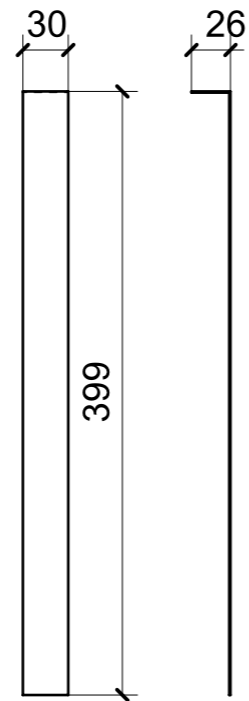

A10\_02

ELEMENTI DA MONTARE CON L01\_01/07 IN MF\_AV01  
e spedire con unico imballo

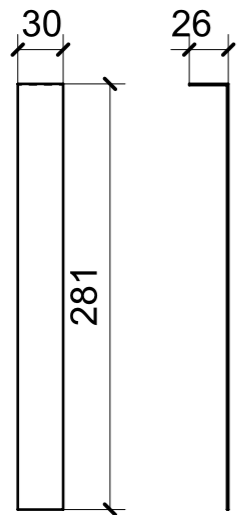
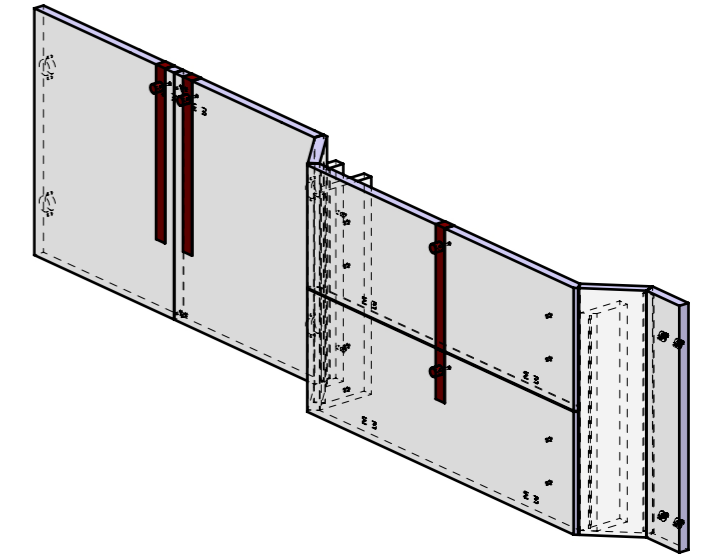

A11\_01

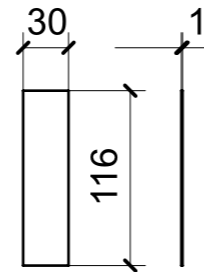

A12\_01

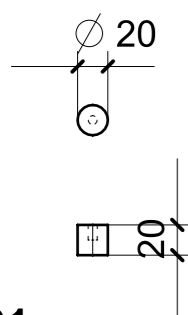
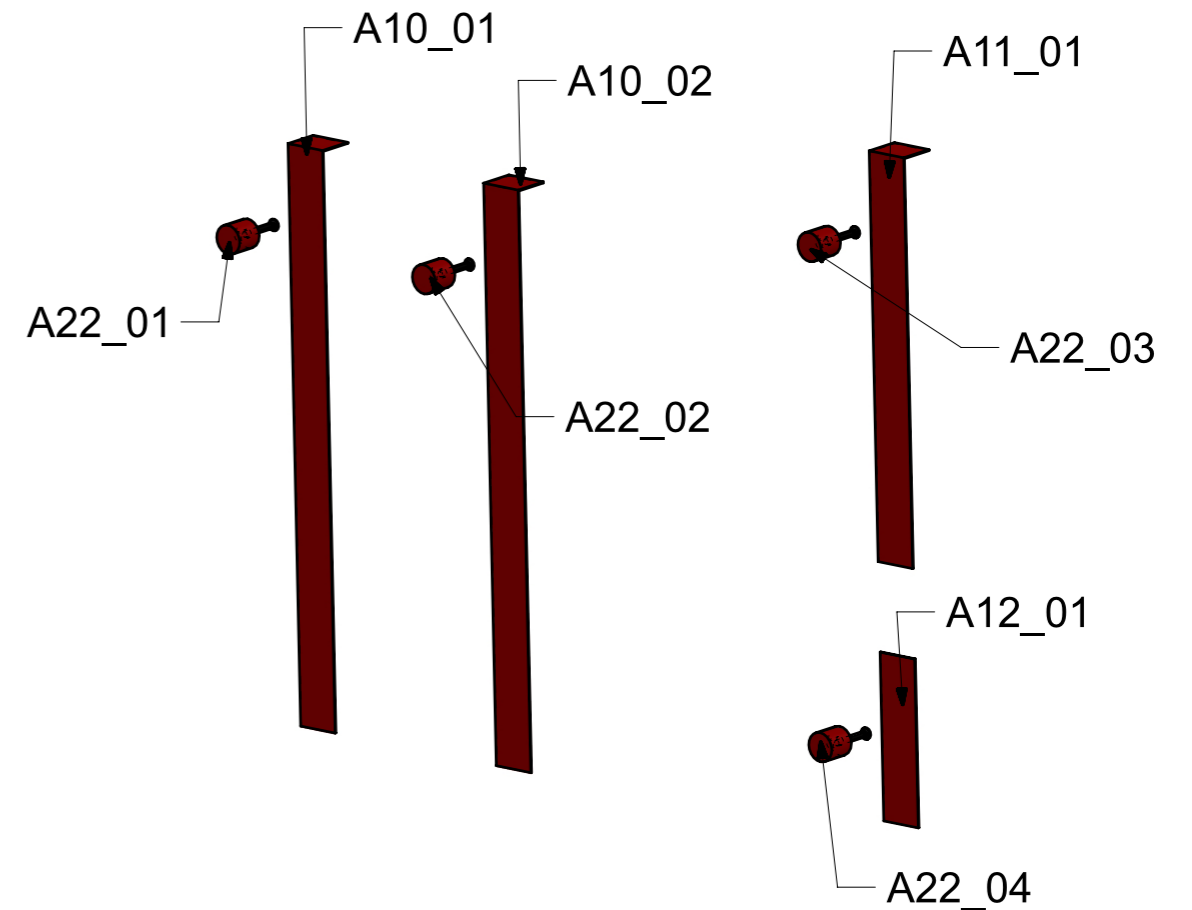

A22\_01

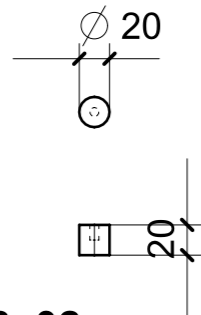

A22\_02

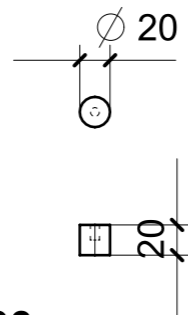

A22\_03

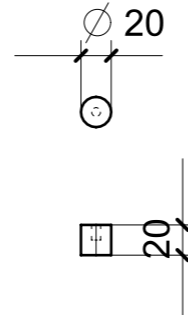

A22\_04

LOCALE	CODICE	DESCRIZIONE COMPONENTE	FINITURA	Q.TA
CABINA ARMATORE	MD299_R01_AW01	RIV.BAGNO OSPITI DX_STD VAR 1 CON VANITY	LASTRA SCURA	1

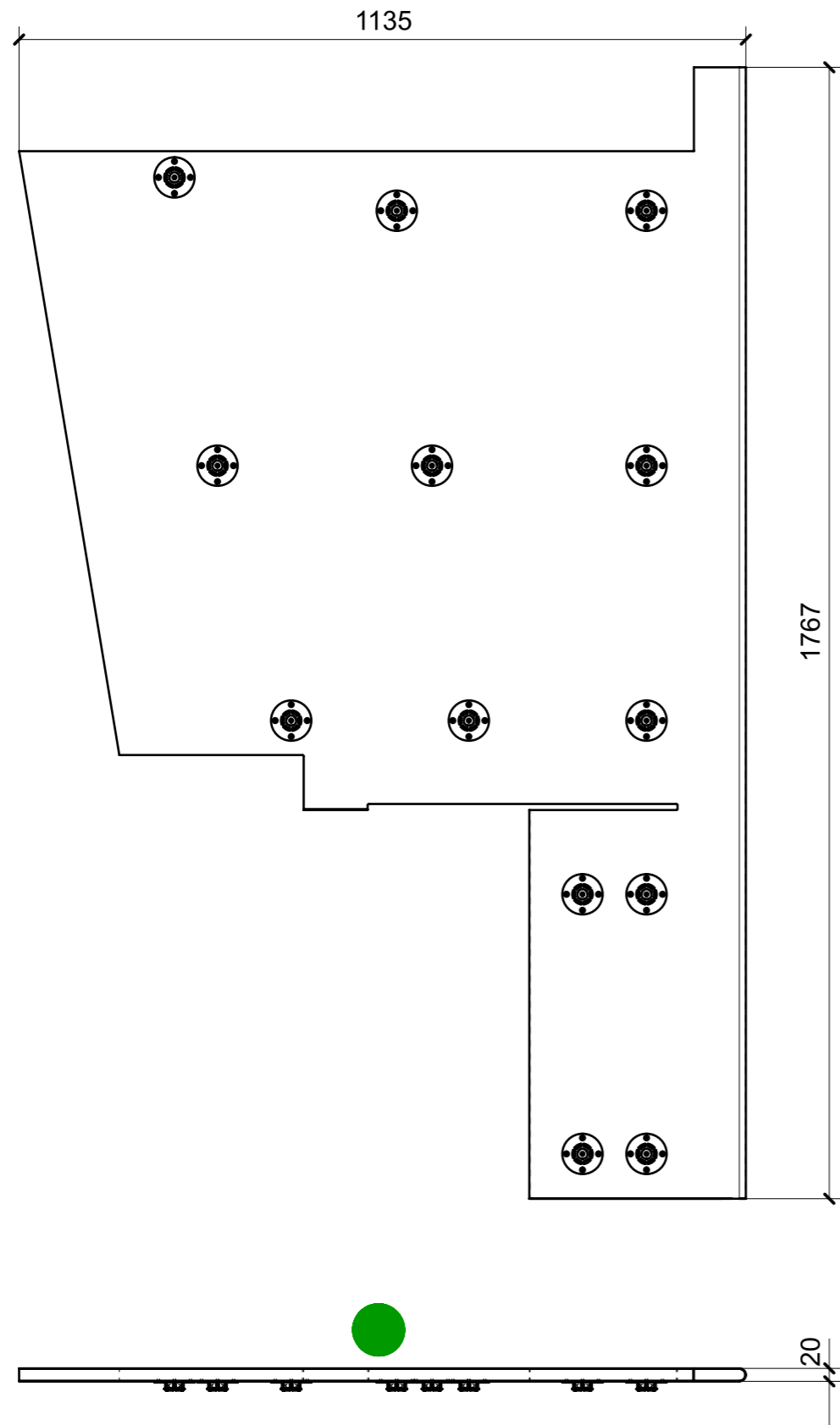

01

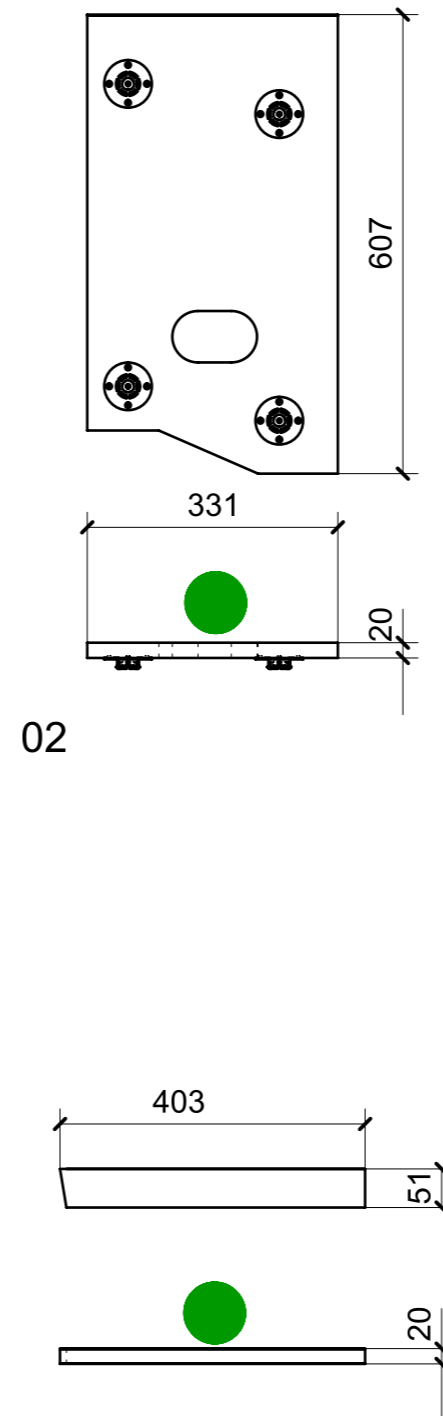

02

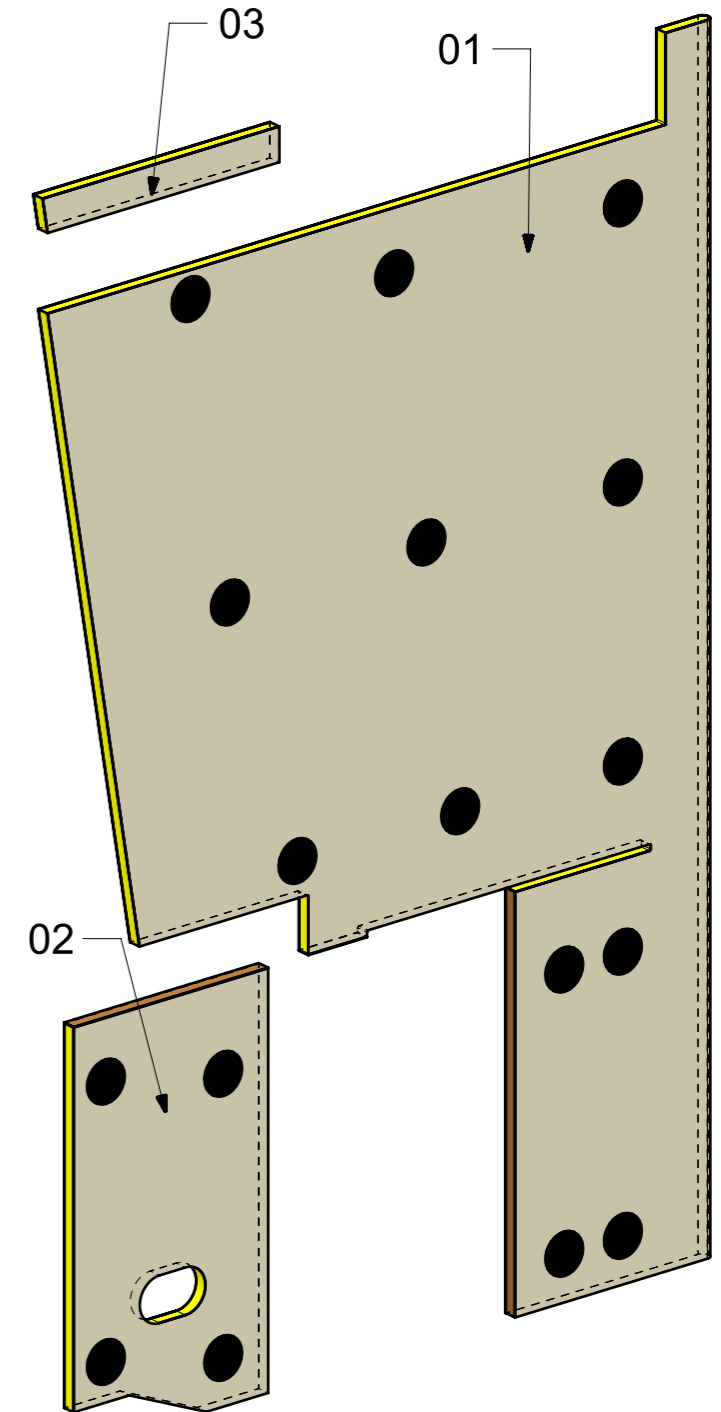

FERRAMENTA	QTY
FITLOCK M_MASCHERPA_3MM_6020202101	17

VERNICIATURA LASTRA/LACCATI:

● = VERNICIARE 1 LATO + FILI RASATI O BORDATI

NESSUN SIMBOLO = VERNICIARE 2 LATI + FILI RASATI O BORDATI

LOCALE	CODICE	DESCRIZIONE COMPONENTE	FINITURA	Q.TA
CABINA ARMATORE	MD299_MF_AAQ01	COMODINO SX_STD VAR 2		1

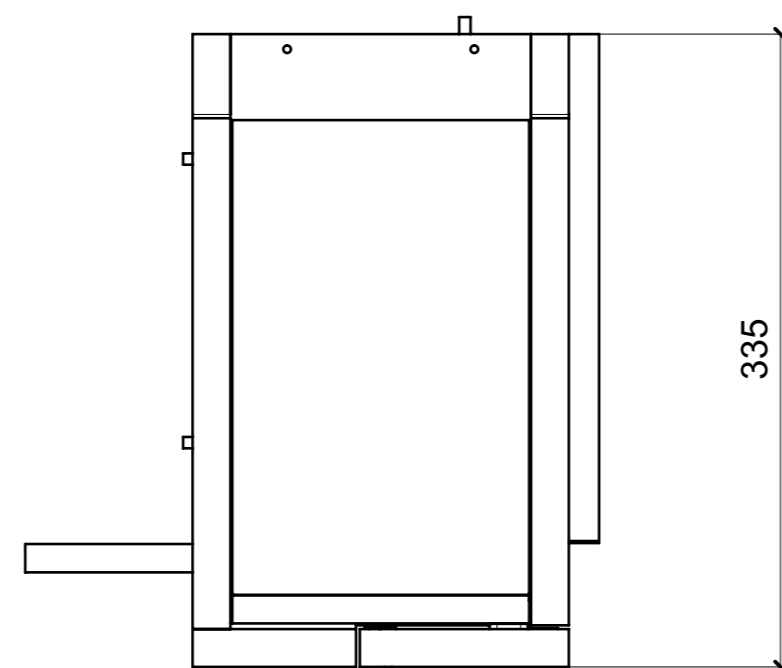
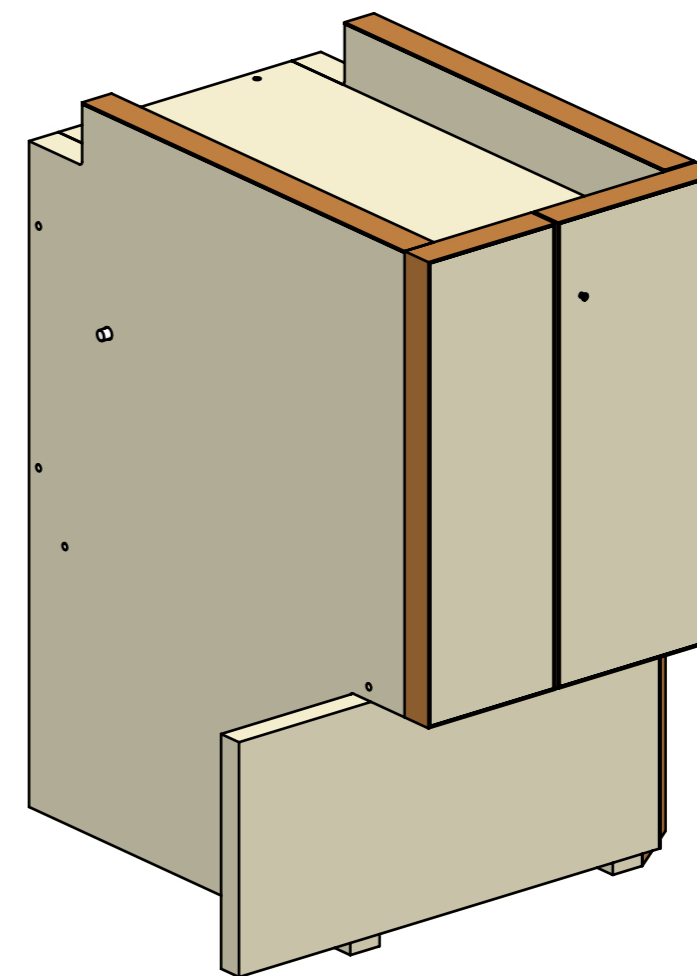
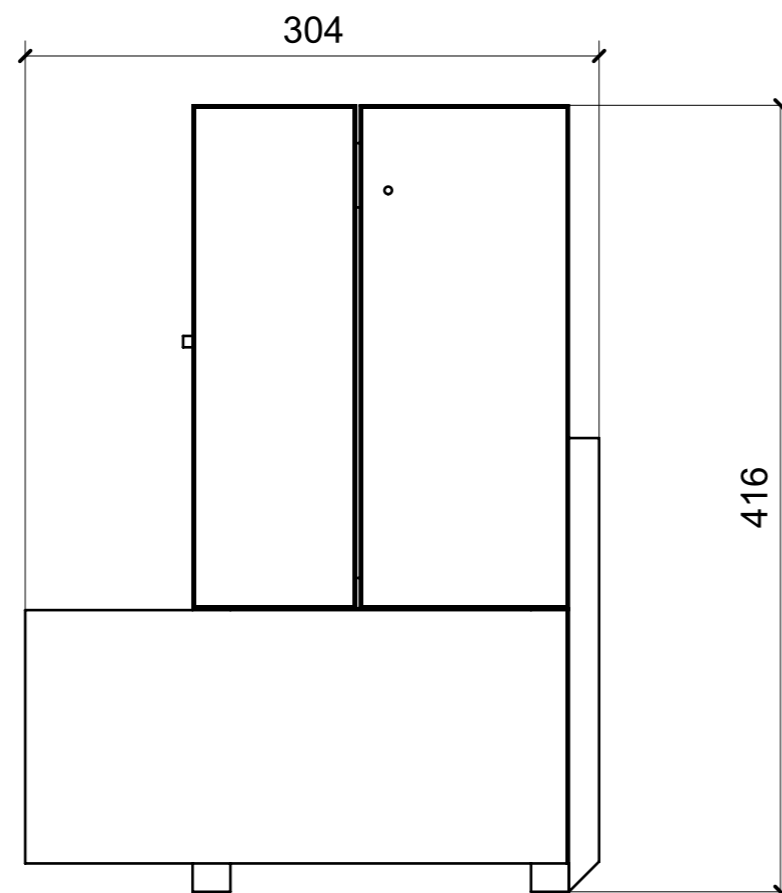

FERRAMENTA	QTY
BASE_0_HAFELE_329_84_020	2
BUSSOLA 5MA ANKOR BORGHI X BASE 0	4
BUSSOLA 5MA ANKOR BORGHI X CERNIERA PIANA	4
CERNIERA 94° PIANA AMMORTIZZATA_HAFELE_329_49_310	2
CHIUSURA A SPINTA_TECHNOPARTNER_SOU C3-203	2
GOMMINO PARACOLPO ANTA	2
VITE 4MA X 25 TESTA SVASATA ESAGONALE NERA	1
VITE 4MAX8 ANKOR BORGHI X BASE 0	4
VITE 4MAX8 ANKOR BORGHI X CERNIERA PIANA	4
VITE 6MA X 25 TESTA BOMBATA	4

LOCALE	CODICE	DESCRIZIONE COMPONENTE	FINITURA	Q.TA
CABINA ARMATORE	MD299_R01_AAQ01	COMODINO SX_STD VAR 2	LASTRA SCURA	1

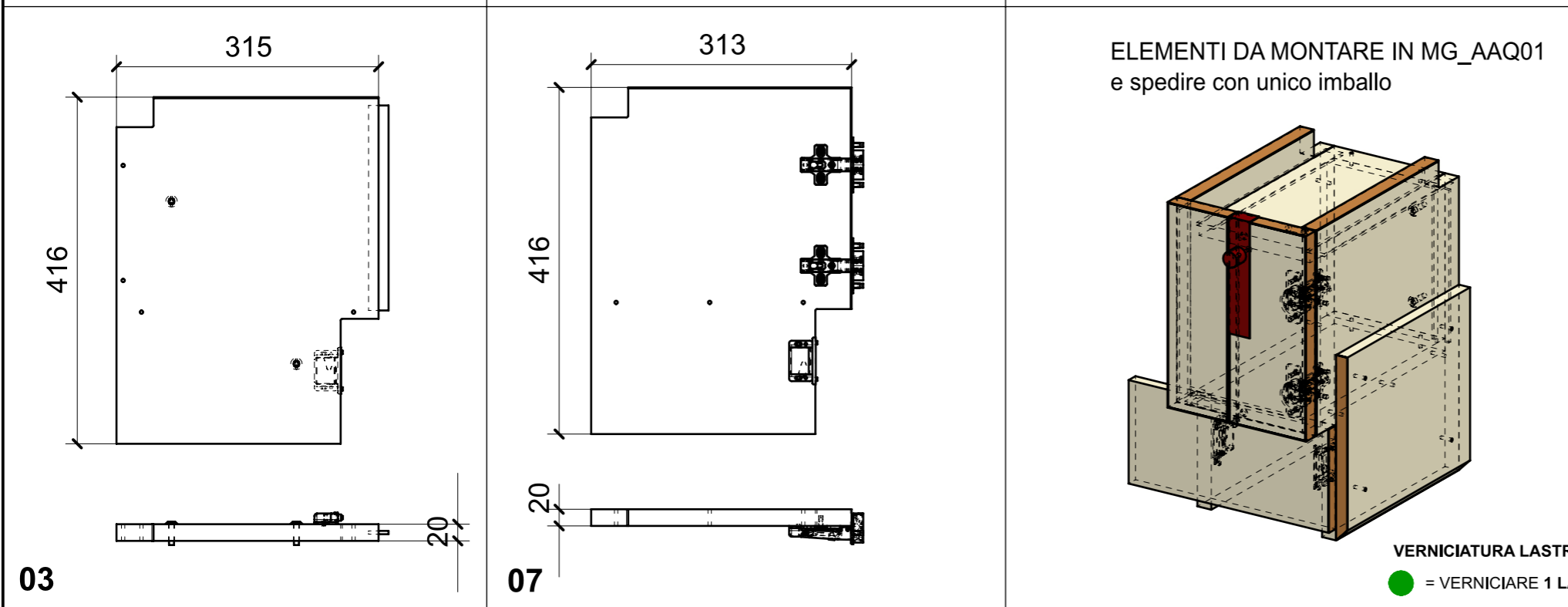
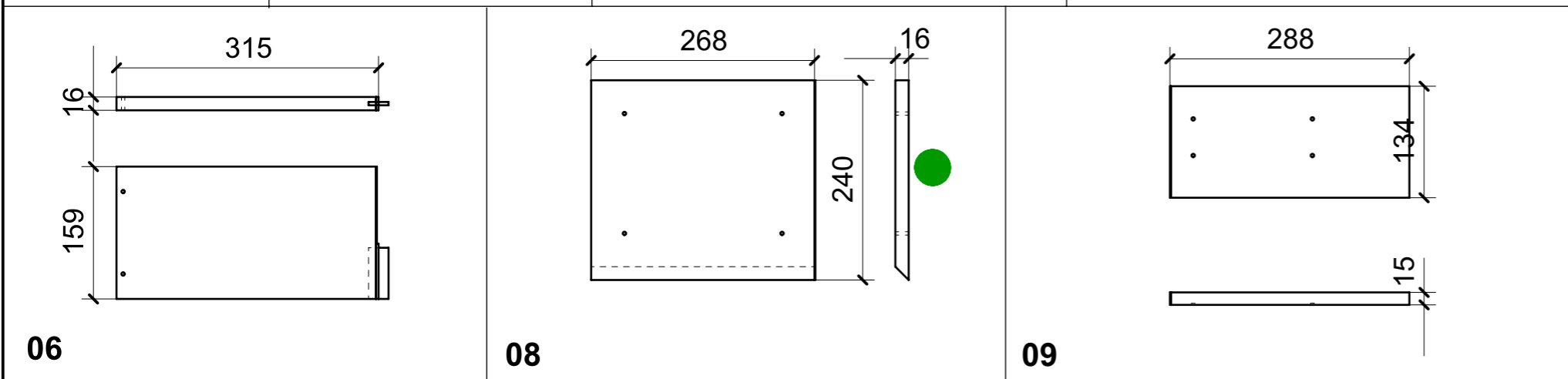
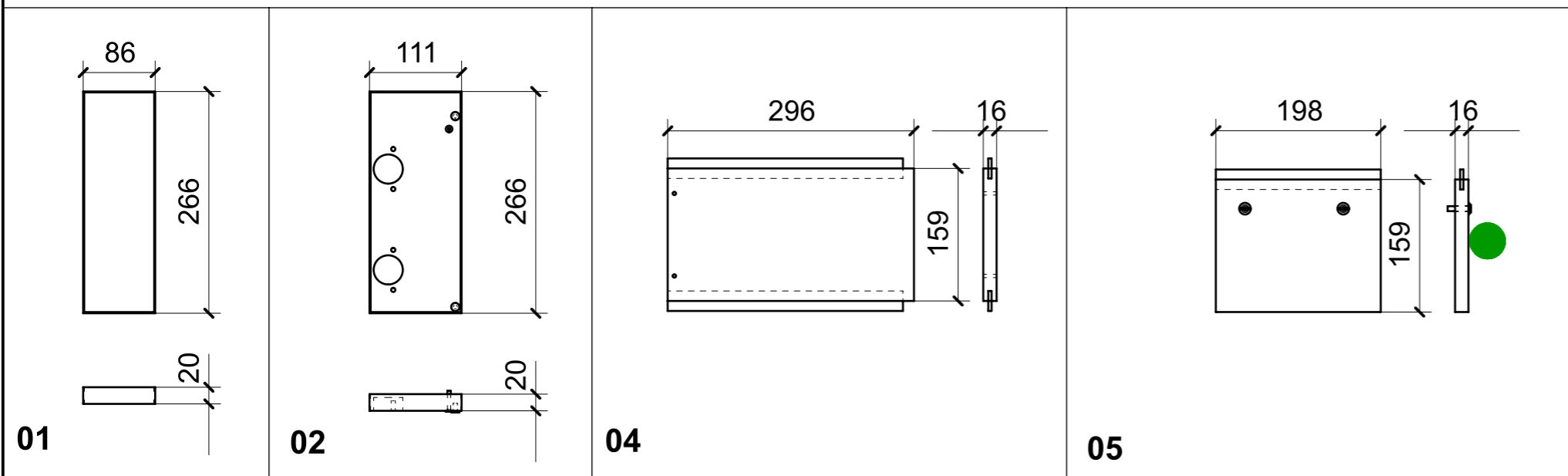

ELEMENTI DA MONTARE IN MG\_AAQ01  
e spedire con unico imballo

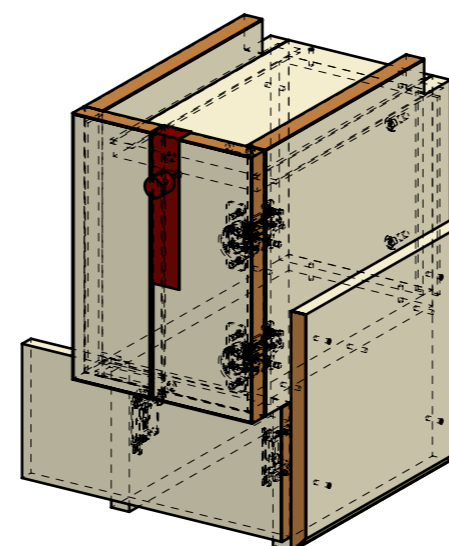

VERNICIATURA LASTRA/LACCATI:

● = VERNICIARE 1 LATO + FILI RASATI O BORDATI

NESSUN SIMBOLO = VERNICIARE 2 LATI + FILI RASATI O BORDATI

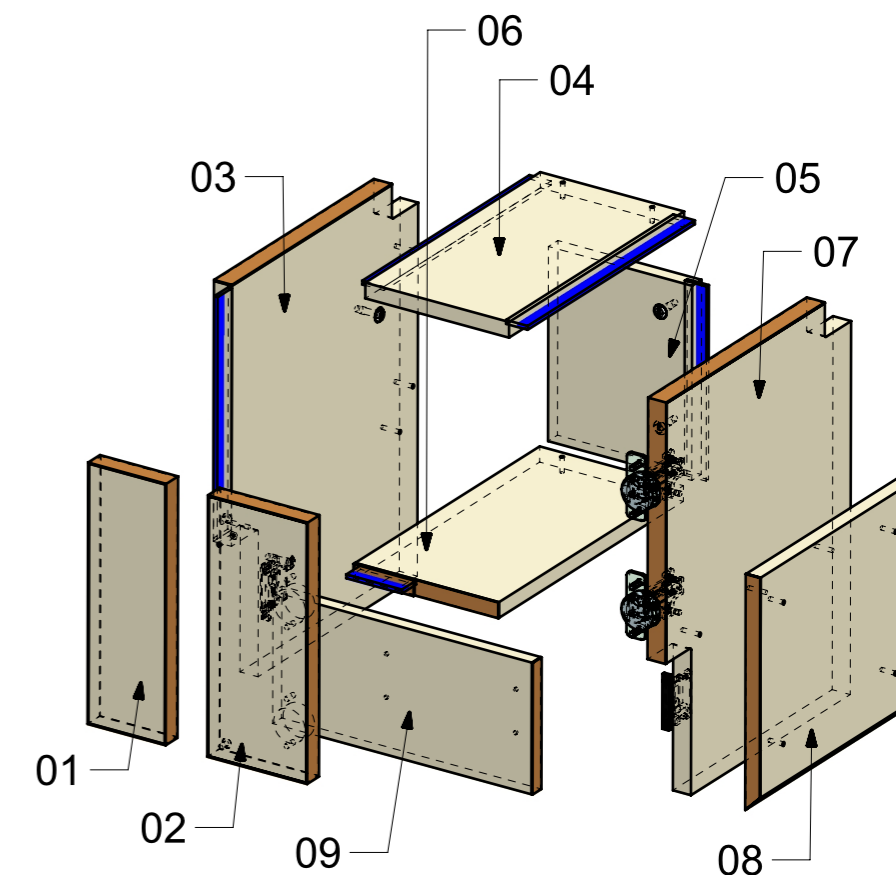

FERRAMENTA	QTY
BASE_0_HAFELE_329_84_020	2
BUSSOLA 5MA ANKOR BORGHI X BASE 0	4
BUSSOLA 5MA ANKOR BORGHI X CERNIERA PIANA	4
CERNIERA 94° PIANA AMMORTIZZATA_HAFELE_329_49_310	2
CHIUSURA A SPINTA_TECHNOPARTNER_SOU C3-203	2
GOMMINO PARACOLPO ANTA	2
VITE 4MA X 25 TESTA SVASATA ESAGONALE NERA	1
VITE 4MAX8 ANKOR BORGHI X BASE 0	4
VITE 4MAX8 ANKOR BORGHI X CERNIERA PIANA	4
VITE 6MA X 25 TESTA BOMBATA	4

LOCALE	CODICE	DESCRIZIONE COMPONENTE	FINITURA	Q.TA
CABINA ARMATORE	MD299_MG_AAR01	COMODINO DX_STD VAR 2		1

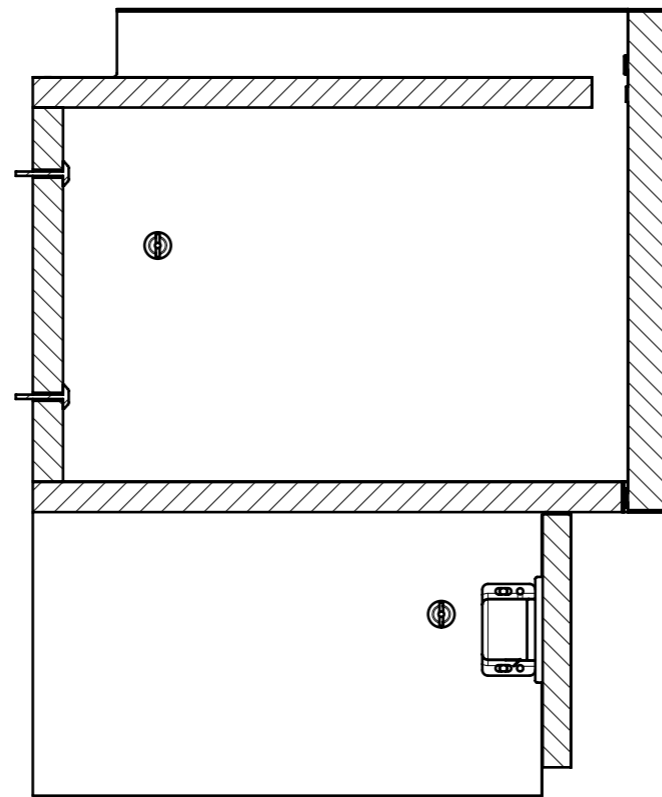
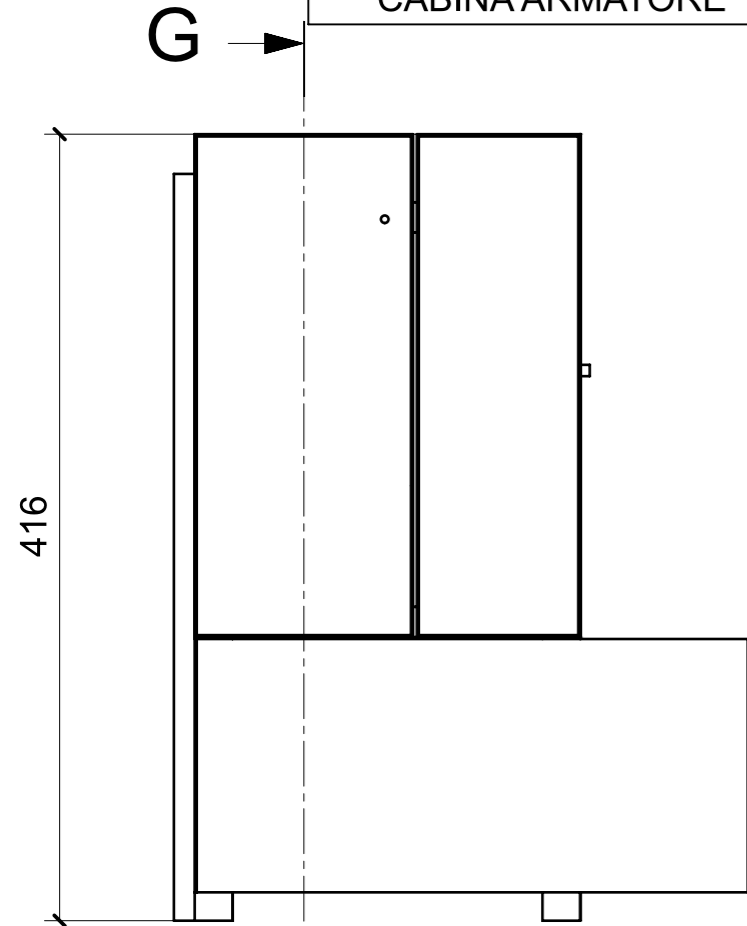

SECTION G-G

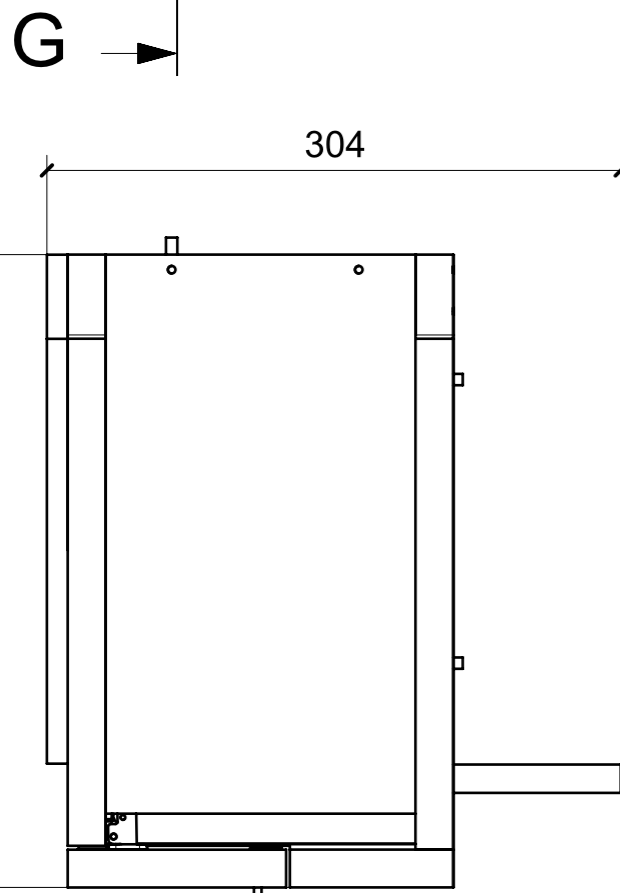
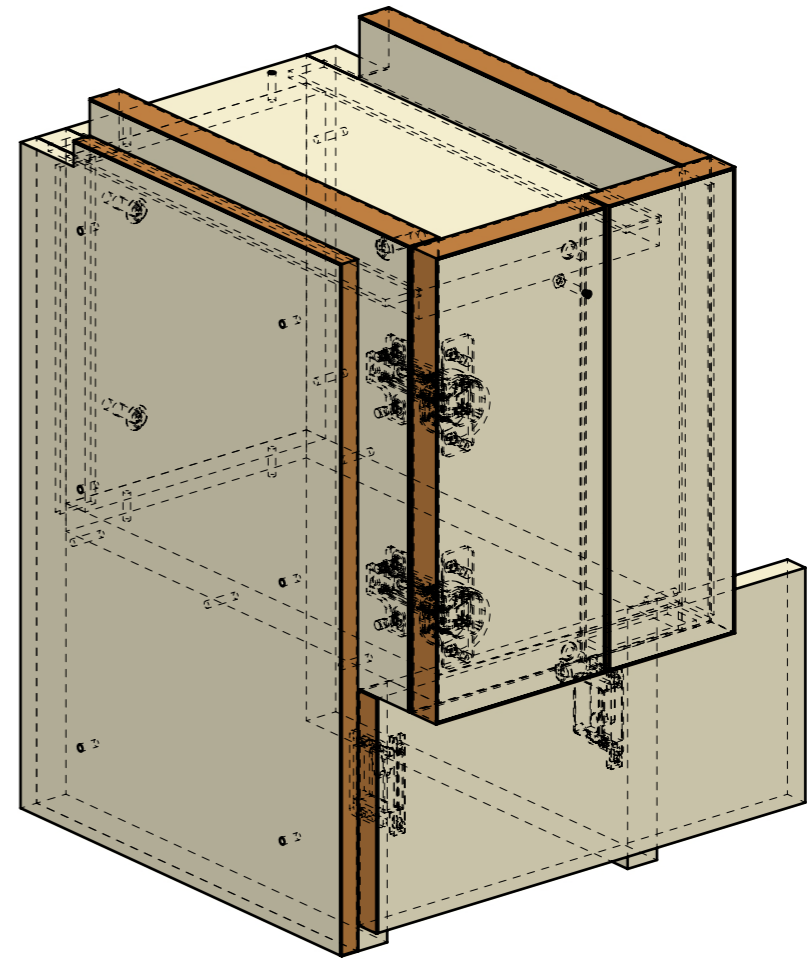

FERRAMENTA	QTY
BASE_0_HAFELE_329_84_020	2
BUSSOLA 5MA ANKOR BORGHI X BASE 0	4
BUSSOLA 5MA ANKOR BORGHI X CERNIERA PIANA	4
CERNIERA 94° PIANA AMMORTIZZATA_HAFELE_329_49_310	2
CHIUSURA A SPINTA_TECHNOPARTNER_SOU C3-203	2
GOMMINO PARACOLPO ANTA	2
VITE 4MA X 25 TESTA SVASATA ESAGONALE NERA	1
VITE 4MAX8 ANKOR BORGHI X BASE 0	4
VITE 4MAX8 ANKOR BORGHI X CERNIERA PIANA	4
VITE 6MA X 25 TESTA BOMBATA	4

LOCALE	CODICE	DESCRIZIONE COMPONENTE	FINITURA	Q.TA
CABINA ARMATORE	MD299_R01_AAR01	COMODINO DX_STD VAR 2	LASTRA SCURA	1

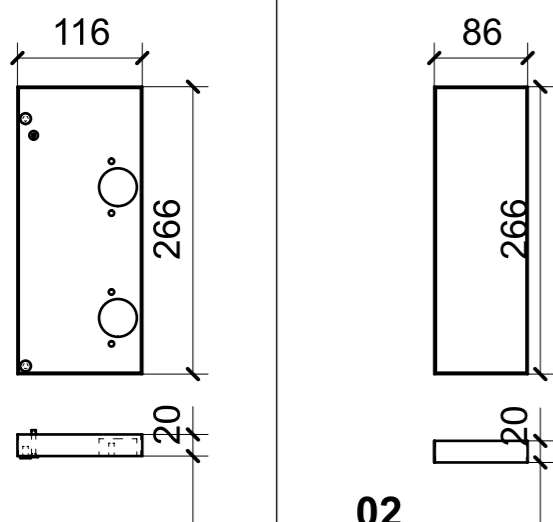

01

02

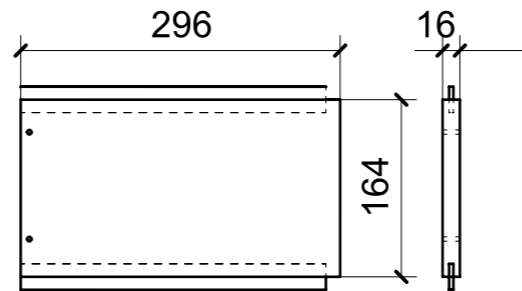

05

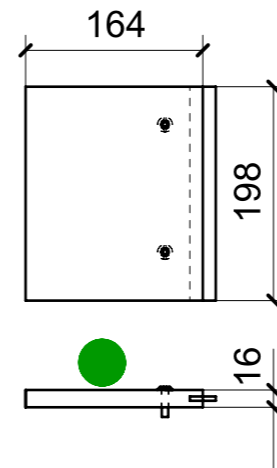

06

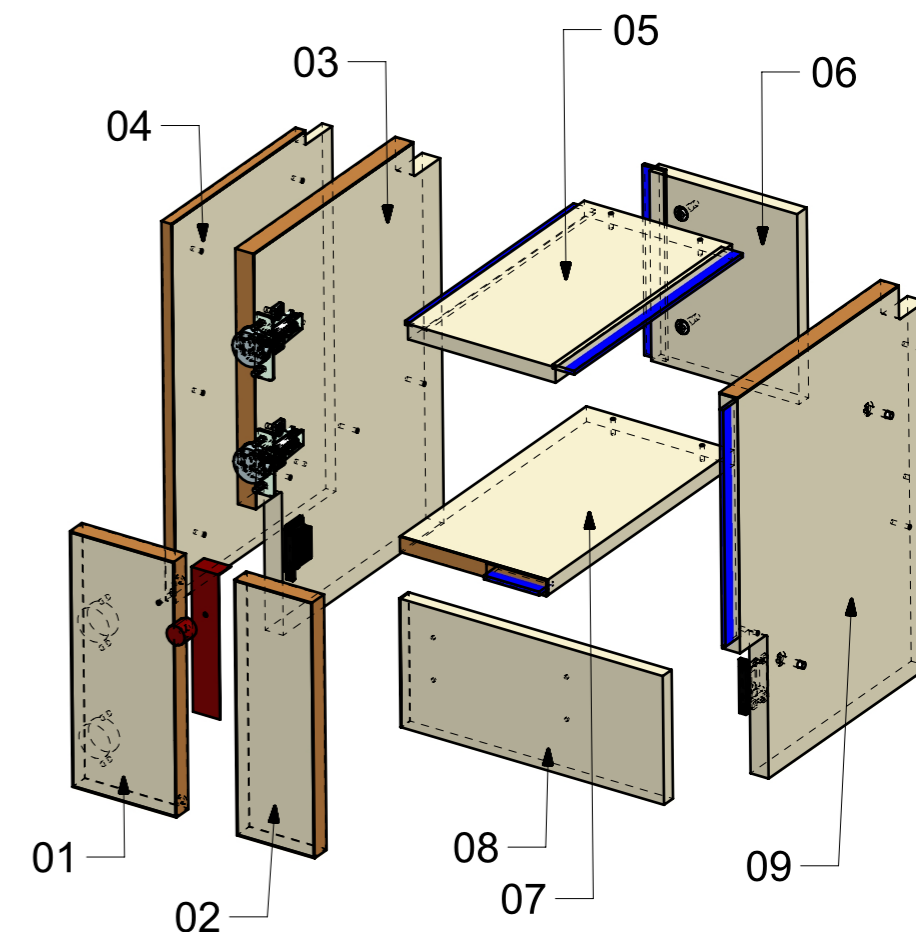

01

02

03

08

07

05

09

06

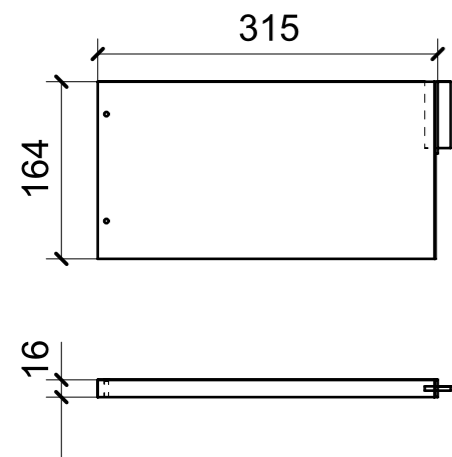

07

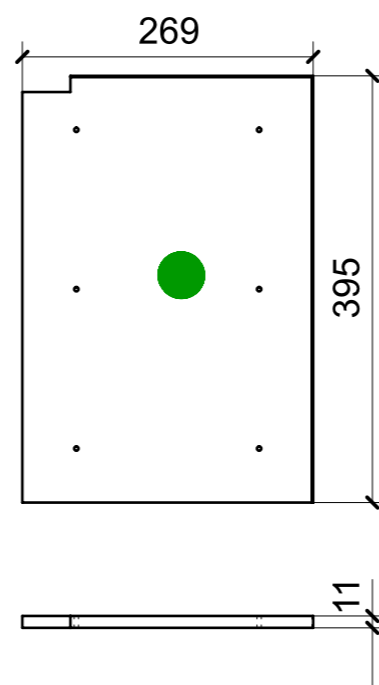

04

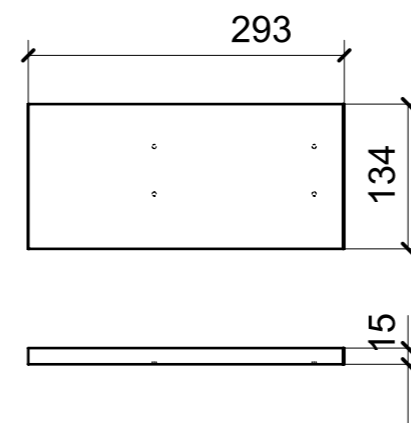

08

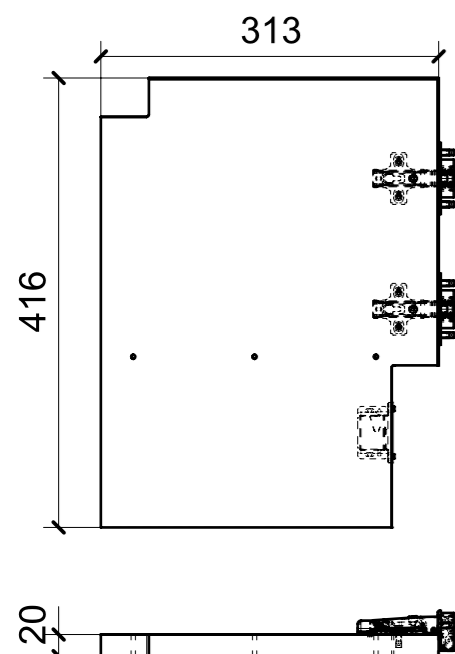

03

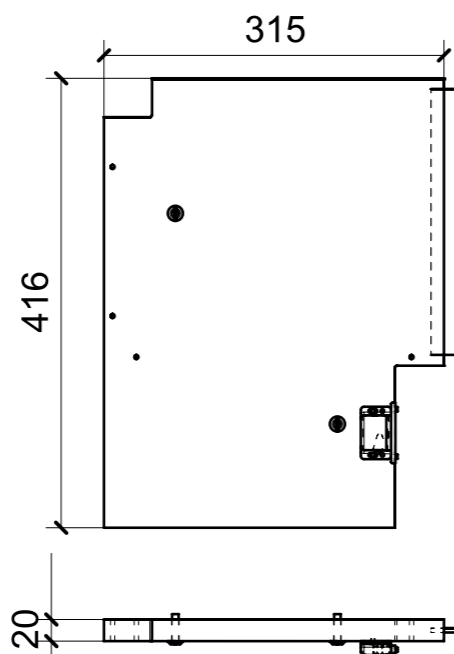

09

ELEMENTI DA MONTARE IN MG\_AAR01  
e spedire con unico imballo

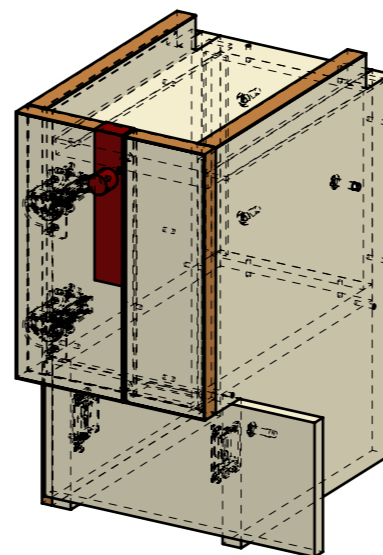

VERNICIATURA LASTRA/LACCATI:

● = VERNICIARE 1 LATO + FILI RASATI O BORDATI

NESSUN SIMBOLO = VERNICIARE 2 LATI + FILI RASATI O BORDATI

FERRAMENTA	QTY
MD299_GR06_A22_AAR01_01	1
MD299_GR06_A09_AAR01_01	1
BASE_0_HAFELE_329_84_020	2
BUSSOLA 5MA ANKOR BORGHI X BASE 0	4
BUSSOLA 5MA ANKOR BORGHI X CERNIERA PIANA	4
CERNIERA 94° PIANA AMMORTIZZATA_HAFELE_329_49_310	2
CHIUSURA A SPINTA_TECHNOPARTNER_SOU C3-203	2
GOMMINO PARACOLPO ANTA	2
VITE 4MA X 25 TESTA SVASATA ESAGONALE NERA	1
VITE 4MAX8 ANKOR BORGHI X BASE 0	4
VITE 4MAX8 ANKOR BORGHI X CERNIERA PIANA	4
VITE 6MA X 25 TESTA BOMBATA	4