

AZ68F

DA MAT. 201 REV. 29-04-2024

LOCALE	CODICE	DESCRIZIONE COMPONENTE	FINITURA	Q.TA	OPERATORE
CABINA ARMATORE	AZ68F-MF_AE01	GRADINO SX			Damiano

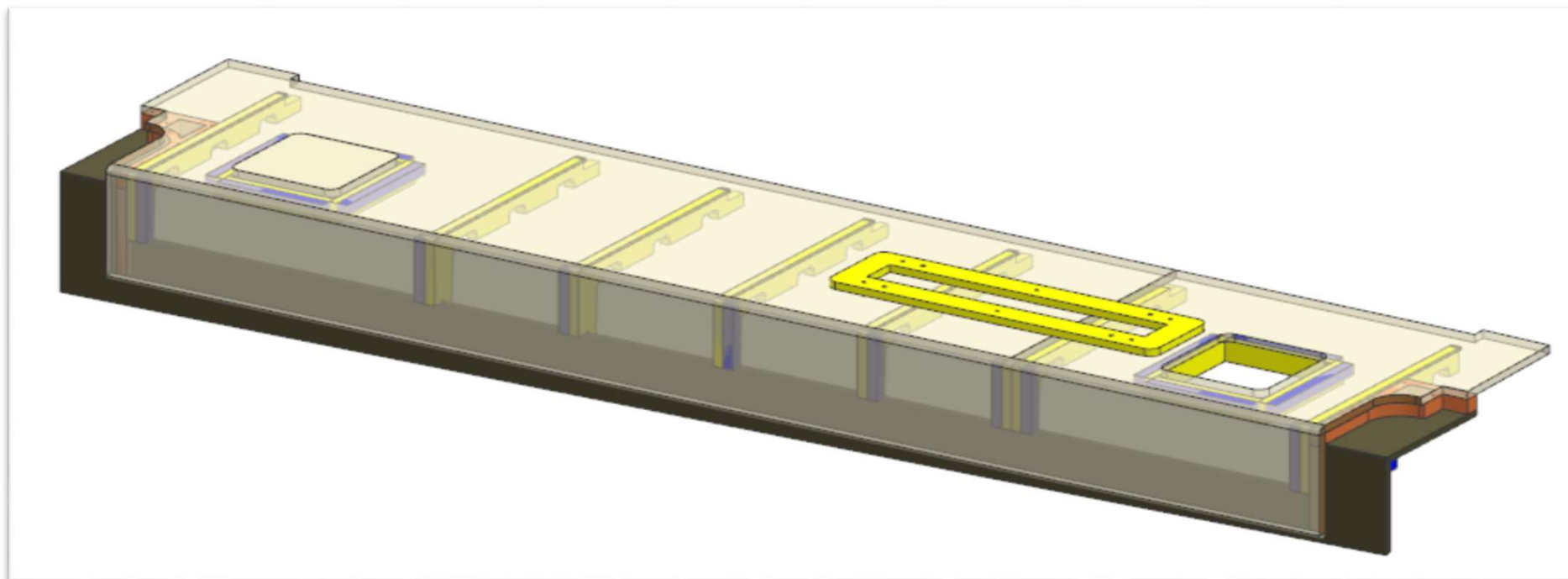

FERRAMENTA:

N° 4 - BUSSOLA ZAMA 6MA
N° 6 - VITI 6MA

AZ68F

DA MAT. 201 REV. 29-04-2024

LOCALE	CODICE	DESCRIZIONE COMPONENTE	FINITURA	Q.TA	OPERATORE
CABINA ARMATORE	AZ68F-AE01	GRADINO SX	OKOUME' GREZZO	5	Damiano

- 1 - L.516 x H.220 x sp 19
- 2 - L.462 x H.220 x sp 19
- 3 - 5 - L.240 x H.240 x 42
- 4 - L.648 x H.170 x sp 15

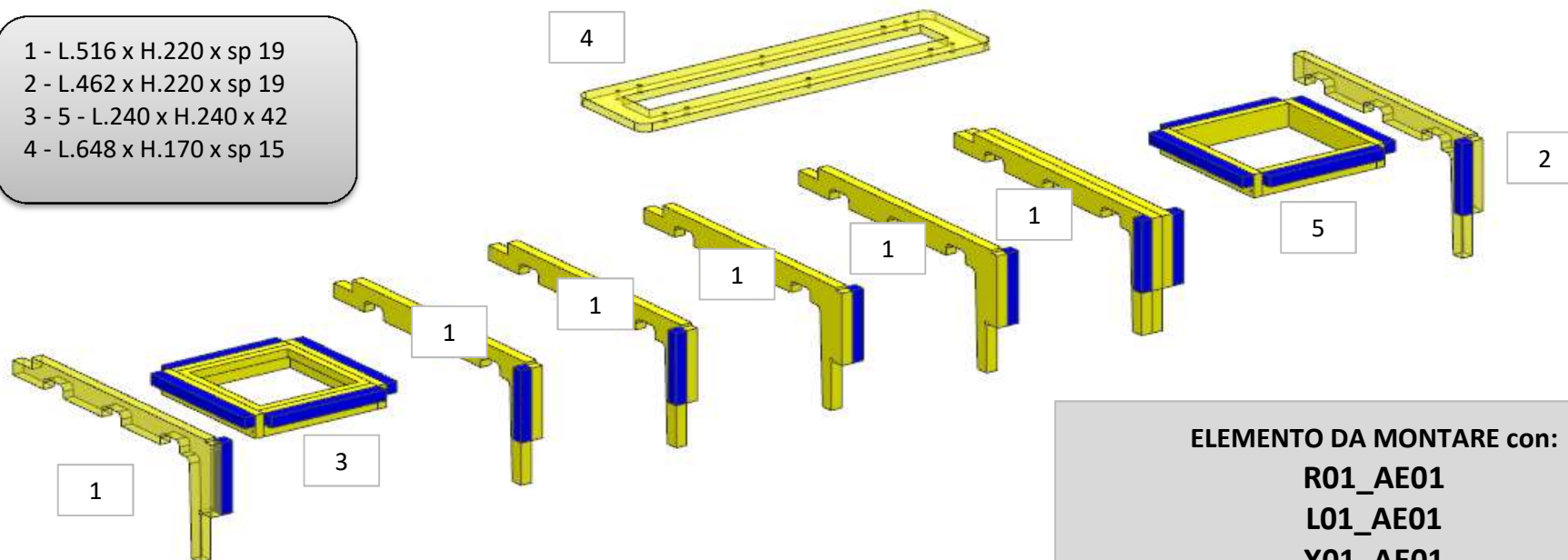

ELEMENTO DA MONTARE con:
R01_AE01
L01_AE01
X01_AE01
 e spedire con un unico imballo

FERRAMENTA:

- N° 4 - BUSSOLA ZAMA 6MA
- N° 6 - VITI 6MA

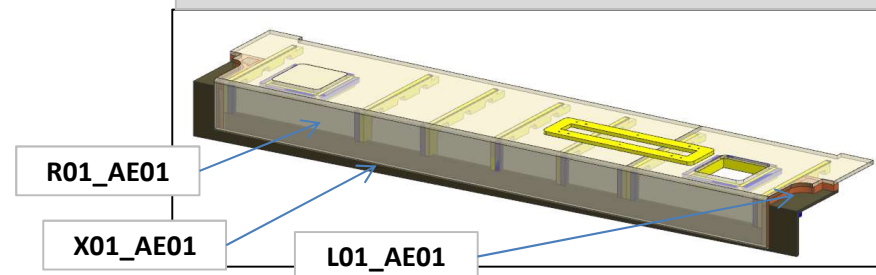

AZ68F

DA MAT 233

REV. 29-04-2024

LOCALE	CODICE	DESCRIZIONE COMPONENTE	FINITURA	Q.TA	OPERATORE
CABINA ARMATORE	AZ68F-R01_AE01	GRADINO SX	LASTRA CHIARA	4	Damiano

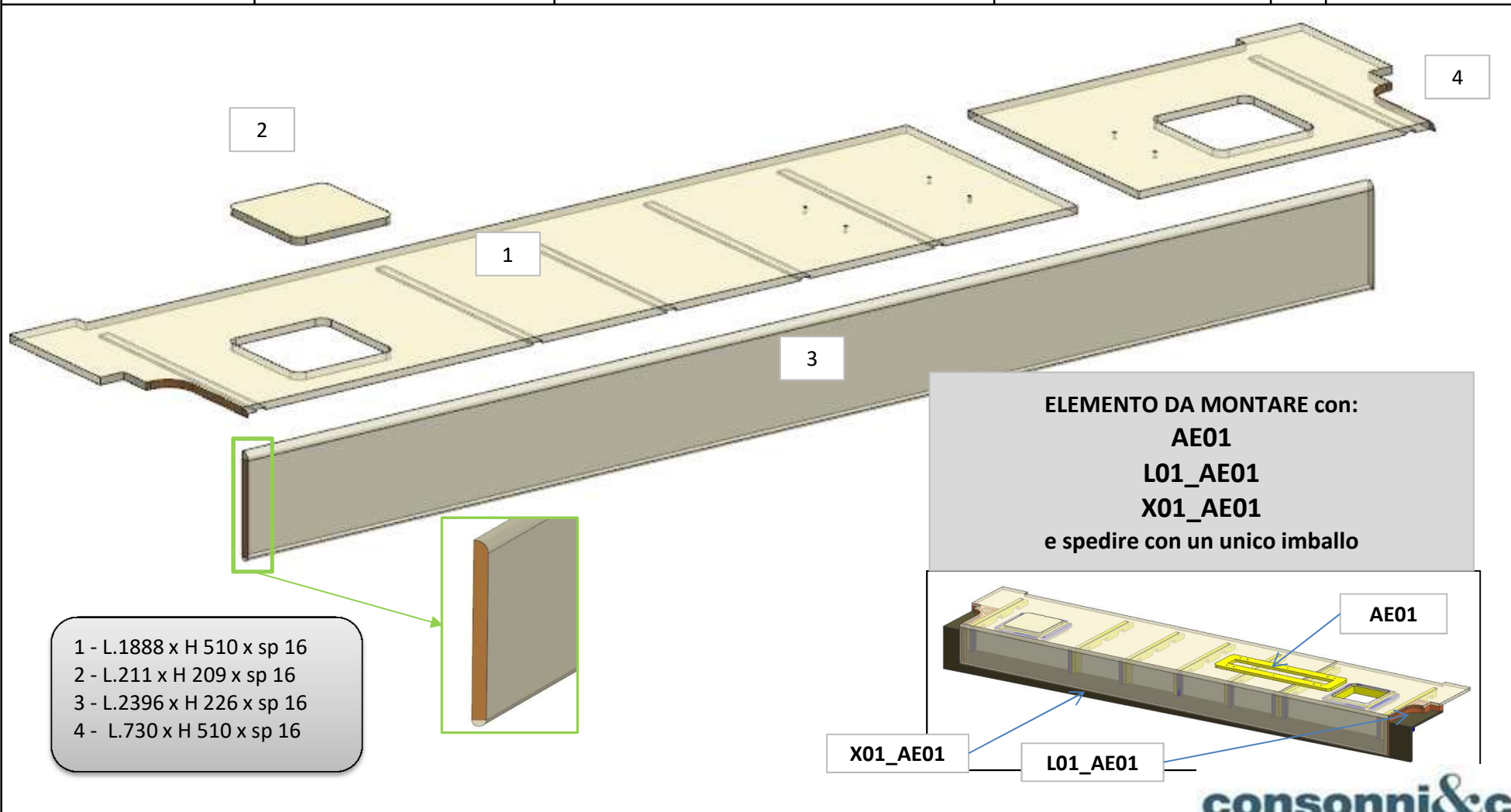

AZ68F

DA MAT. 201 REV. 29-04-2024

LOCALE	CODICE	DESCRIZIONE COMPONENTE	FINITURA	Q.TA	OPERATORE
CABINA ARMATORE	AZ68F-L01_AE01	GRADINO SX	LACCATO BRONZO	4	Damiano

1 - 3 - L.298 x H 141 x sp 30
2 - 4 - L.172 x H 20 x sp 16

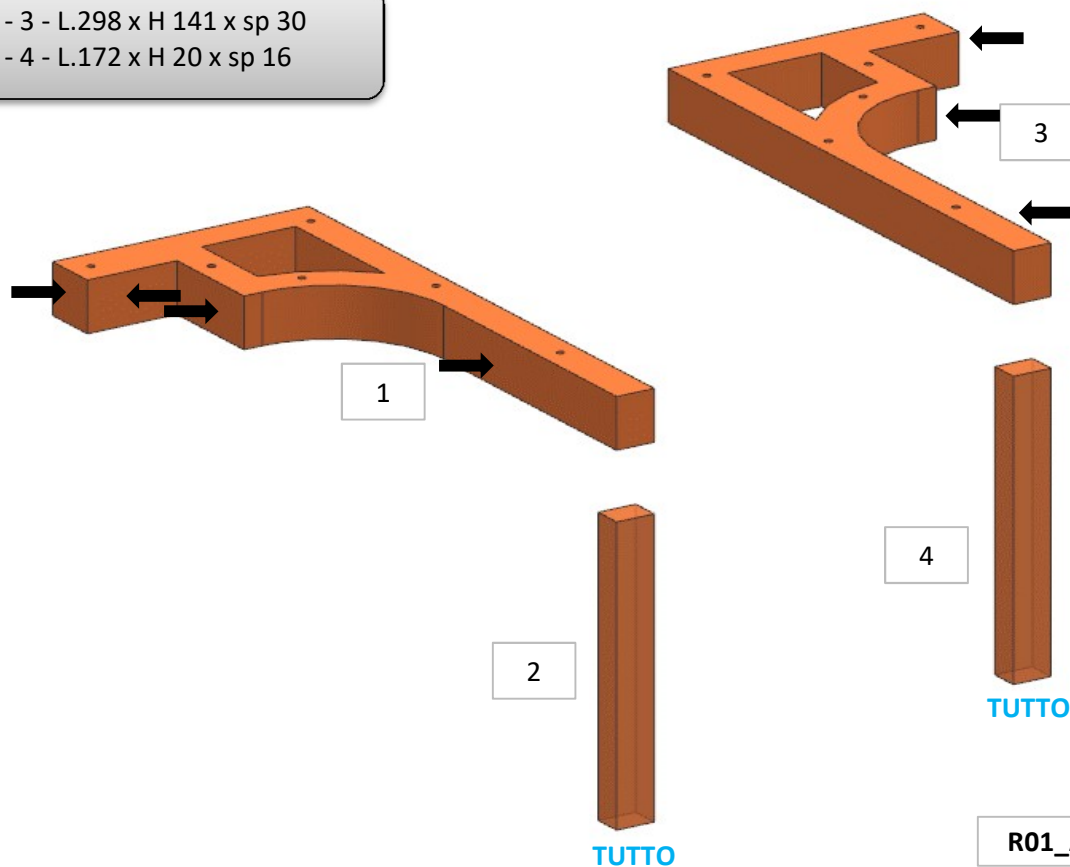

ELEMENTO DA MONTARE con:
R01_AE01
AE01
X01_AE01
e spedire con un unico imballo

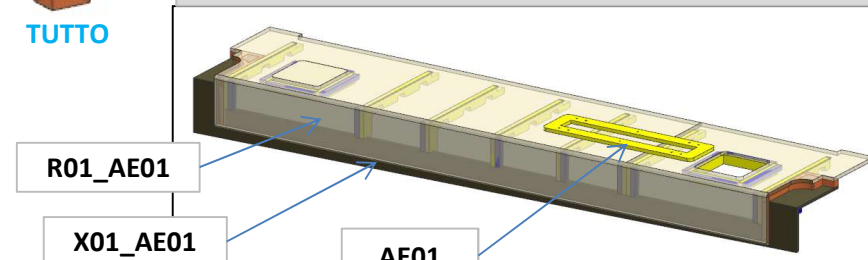

* faccia dove viene applicata la finitura
↓ filo dove viene applicata la finitura

AZ68F

DA MAT. 201 REV. 29-04-2024

LOCALE	CODICE	DESCRIZIONE COMPONENTE	FINITURA	Q.TA	OPERATORE
CABINA ARMATORE	AZ68F-X01_AE01	GRADINO SX	LAMINATO OLIMPUS OL04	3	Damiano

1 - 3 - L.141 x H.280 x sp 12
2 - L.2618 x H.238 x sp 12

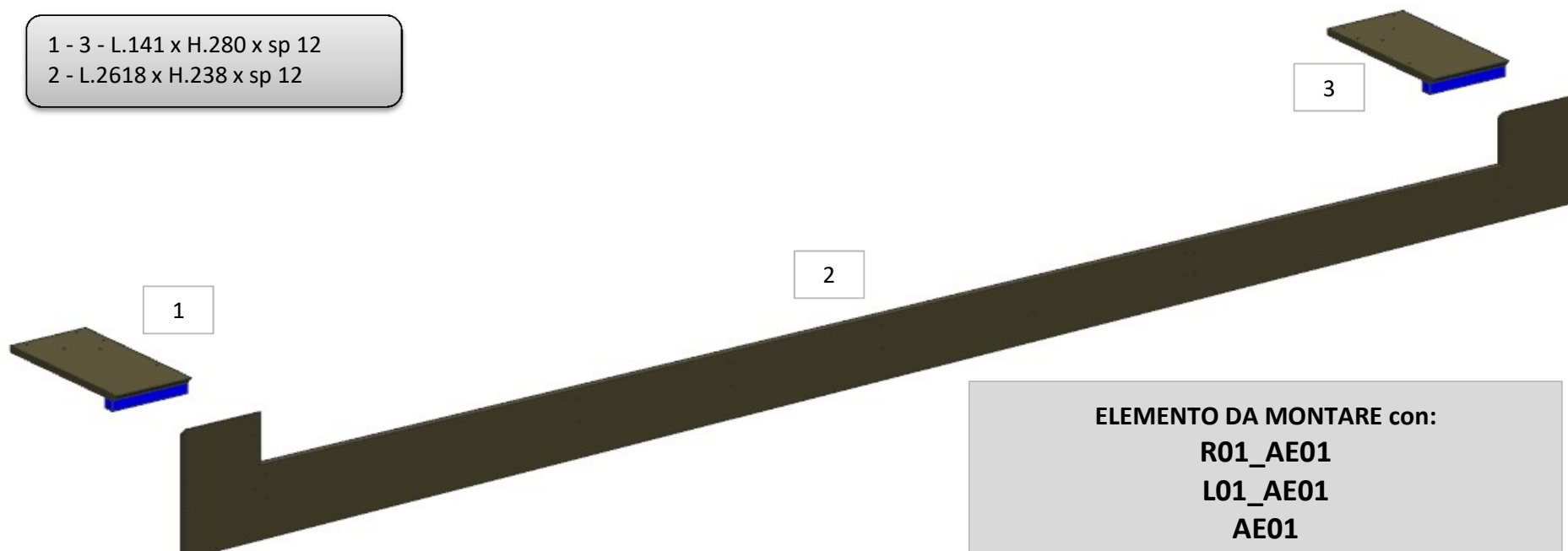

ELEMENTO DA MONTARE con:
R01_AE01
L01_AE01
AE01
e spedire con un unico imballo

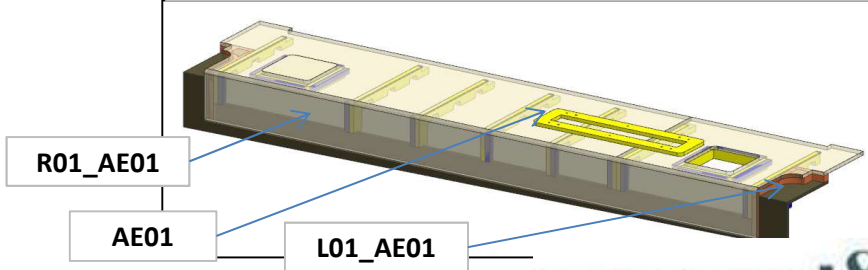

AZ68F

DA MAT. 233 REV. 29-04-2024

LOCALE	CODICE	DESCRIZIONE COMPONENTE	FINITURA	Q.TA	OPERATORE
CABINA ARMATORE	AZ68F-MF_AQ01	LETTO			Damiano

MF_AQ01

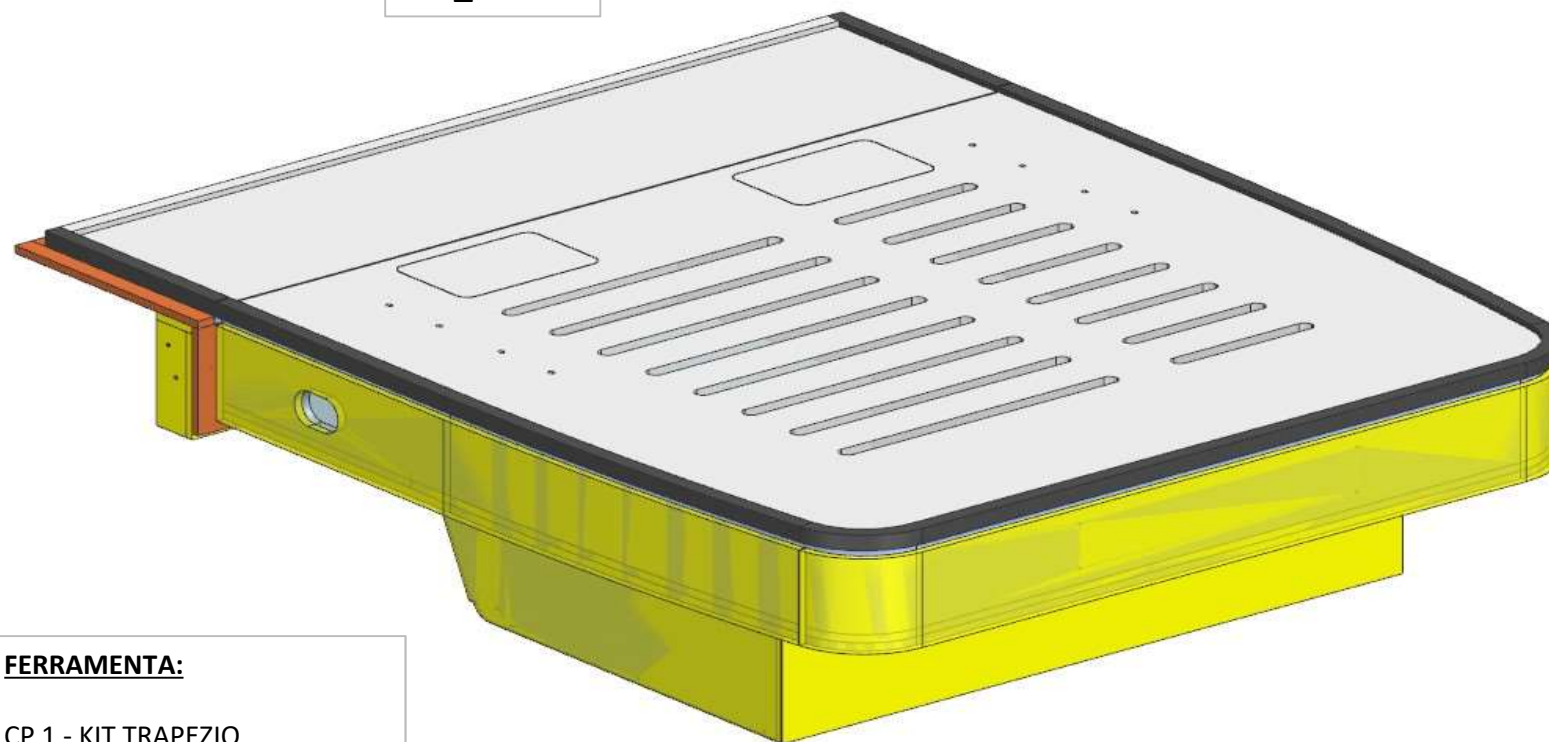

FERRAMENTA:

- CP 1 - KIT TRAPEZIO
- N° 2 - PISTONI GAS
- N° 27 - BUSSOLA ZAMA 6MA
- N° 21 - VITI 6MA

AZ68F

DA MAT. 233 REV. 29-04-2024

LOCALE	CODICE	DESCRIZIONE COMPONENTE	FINITURA	Q.TA	OPERATORE
CABINA ARMATORE	AZ68F-AQ01	LETTO	OKUME' GREZZO \ LAMINATO NADIR \ GOFFRATONE	8	Damiano

SPOSTATI FORI PRESE E ALLUNGATA SCATOLETTA

ATT.NE PEZZI GREZZI SP 10 mm

**ELEMENTO DA MONTARE con:
L01_AQ01
L02_AQ01
e spedire con un unico imballo**

L02_AQ01

L01_AQ01

FERRAMENTA:
 CP 1 - KIT TRAPEZIO
 N° 2 - PISTONI GAS
 N° 27 - BUSSOLA ZAMA 6MA
 N° 21 - VITI 6MA

1 - L.1660 x H.434 x 34
 5 - 6 - L. 287 x H.187 x sp 19
 7 - 8 - L. 289 x H.189 x sp 16

AZ68F

DA MAT. 203 REV. 29-04-2024

LOCALE	CODICE	DESCRIZIONE COMPONENTE	FINITURA	Q.TA	OPERATORE
CABINA ARMATORE	AZ68F-L02_AQ01	LETTO	LACCATO BRONZO	5	Damiano

- 1 - 4 - L 468 x H 35 x sp 15
- 2 - 3 - L 222 x H 208 x sp 15
- 5 - L 1660 x H 34 x sp 15

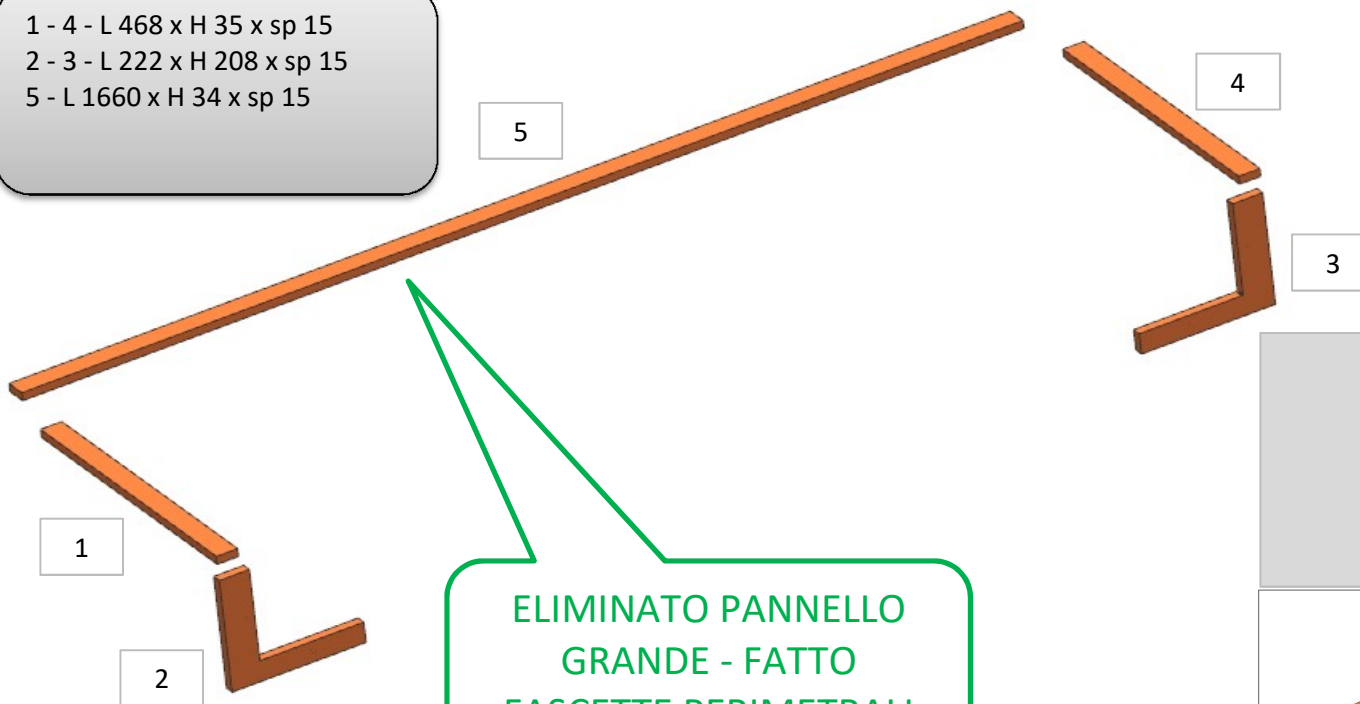

ELEMENTO DA MONTARE con:
AQ01
L01_AQ01
e spedire con un unico imballo

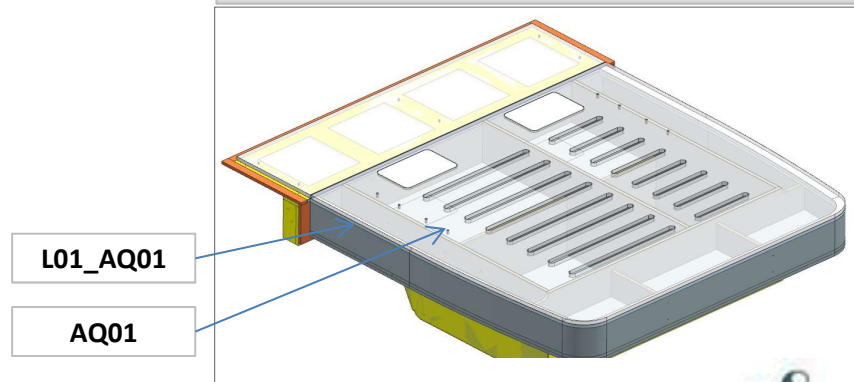

3 e 2 controllare bene la prossima volta

AZ68F

DA MAT. 237 REV. 29-04-2024

LOCALE	CODICE	DESCRIZIONE COMPONENTE	FINITURA	Q.TA	OPERATORE
CABINA ARMATORE	AZ68F-L01_AQ01	LETTO	LACCATO BIANCO ARTICO	3	Damiano

1 - 3 - L 1433 x H 32 x 36
2 - L 1650 x H 32 x 36

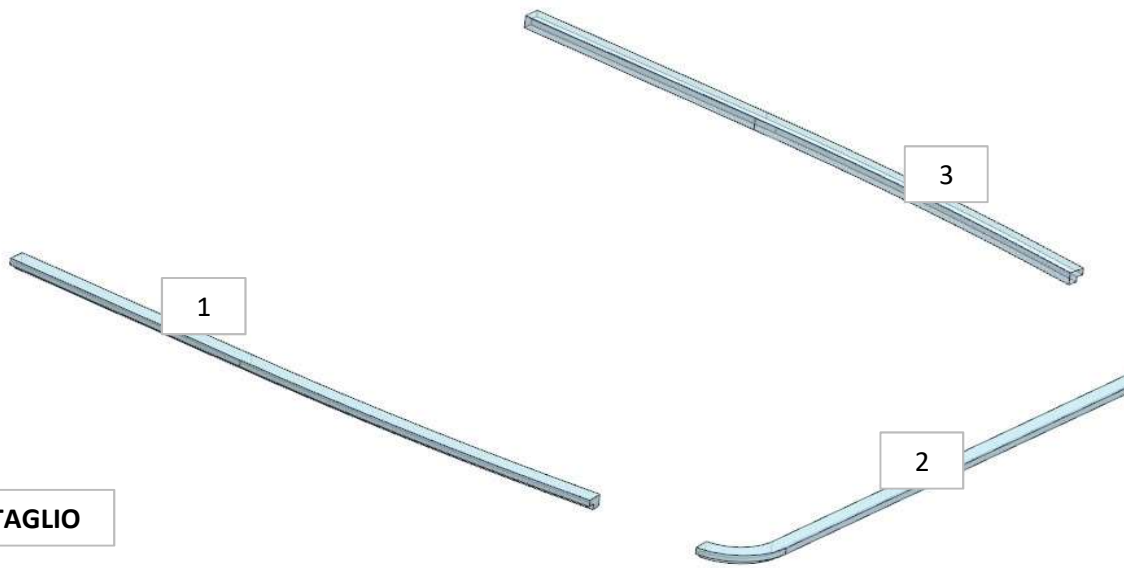

ELEMENTO DA MONTARE con:
AQ01
L02_AQ01
e spedire con un unico imballo

DETTAGLIO

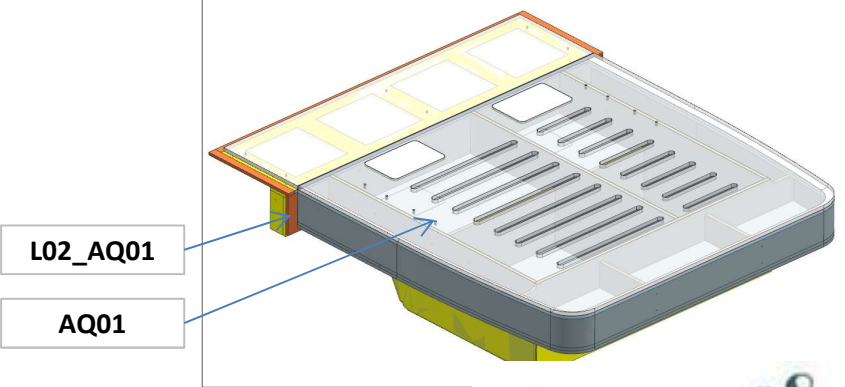
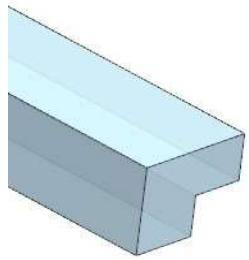

AZ68F

REV. 29-04-2024

LOCALE	CODICE	DESCRIZIONE COMPONENTE	FINITURA	Q.TA	OPERATORE
CABINA ARMATORE	AZ68F-MF_AR01	COMODINO POPPA			Damiano

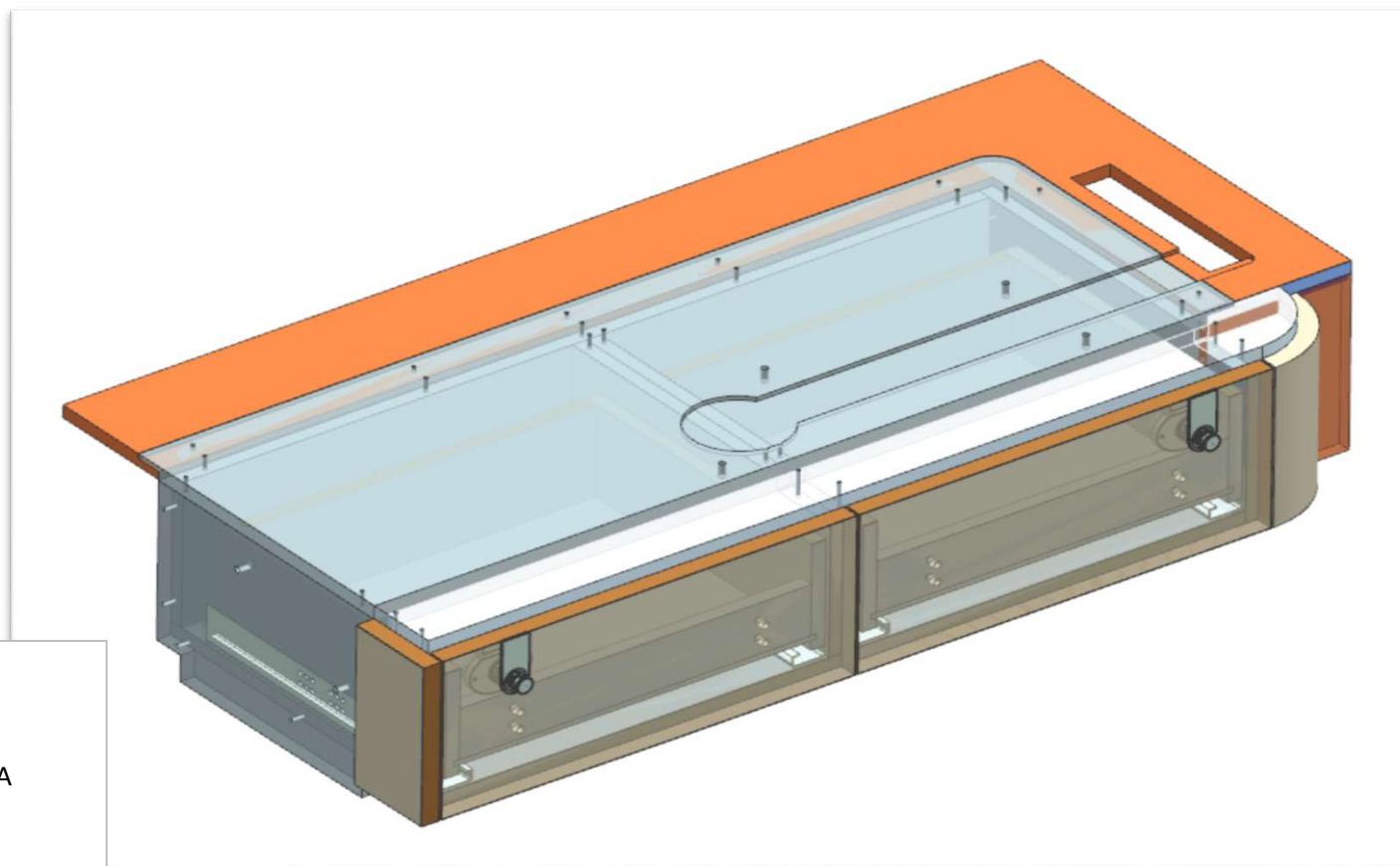

FERRAMENTA:

CP 2 - GUIDE 350
N° 12 - BUSSOLE ZAMA 6MA
N° 12 - VITI 6MA
N° 2 - MANIGLIA FORESTI E
SUARDI

AZ68F

DA MAT. 233 REV. 29-04-2024

LOCALE	CODICE	DESCRIZIONE COMPONENTE	FINITURA	Q.TA	OPERATORE
CABINA ARMATORE	AZ68F-AR01	COMODINO POPPA	LAMINATO NADIR	1	Damiano

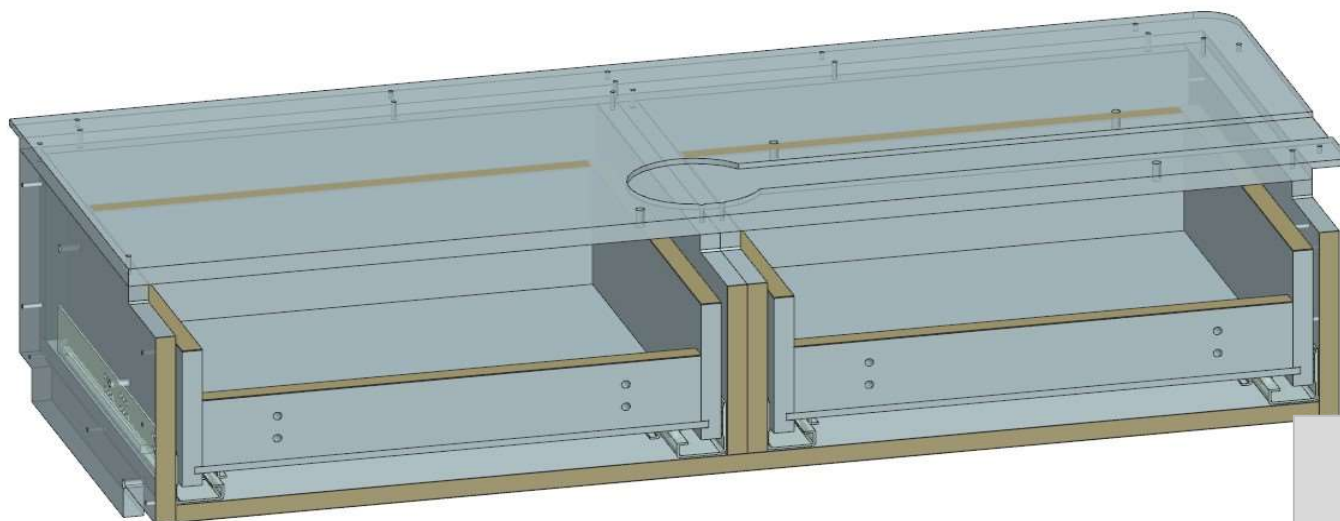

ELEMENTO DA MONTARE con:
R01_AR01
L01_AR01
L02_AR01
e spedire con un unico imballo

FERRAMENTA:

CP 2 - GUIDE 350
N° 12 - BUSSOLE ZAMA 6MA
N° 16 - VITI 6MA
N° 2 - MANIGLIE FORESTI E SUARDI
CON PIASTRA RETTANGOLARE

L02_AR01

L01_AR01

R01_AR01

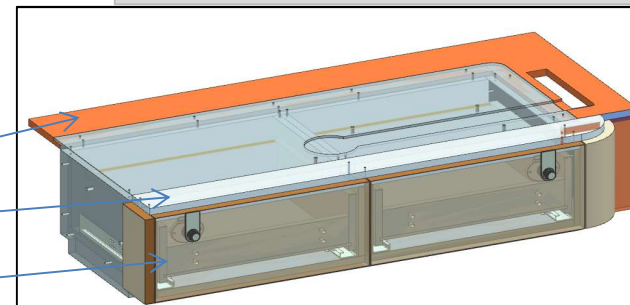

AZ68F

REV. 29-04-2024

LOCALE	CODICE	DESCRIZIONE COMPONENTE	FINITURA	Q.TA	OPERATORE
CABINA ARMATORE	AZ68F-R01_AR01	COMODINO POPPA	LASTRA CHIARA	4	Damiano

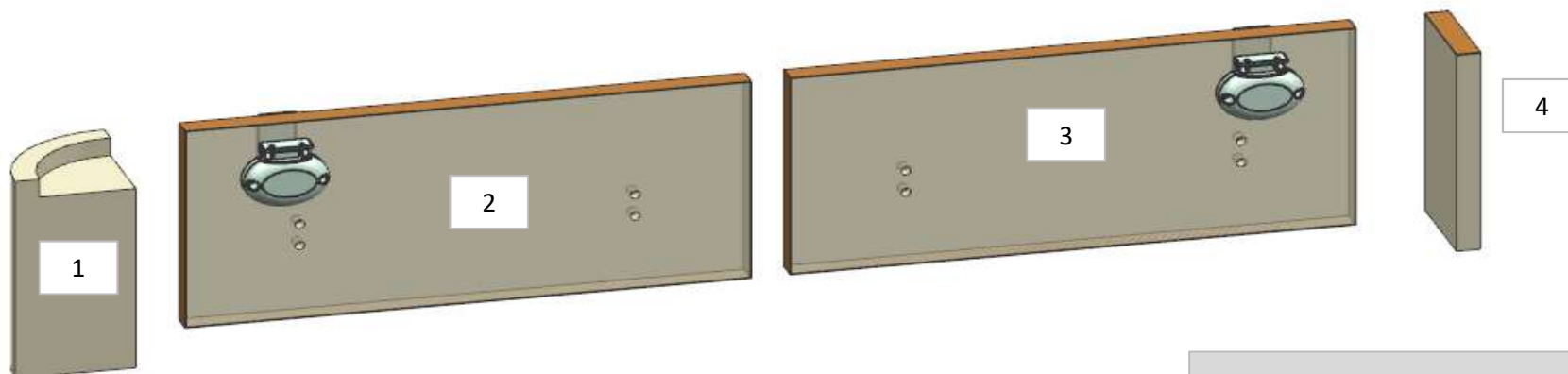

ELEMENTO DA MONTARE con:
AR01
L01_AR01
L02_AR01
e spedire con un unico imballo

1 - L 100 x H189 x 100
2 - 3 - L 469 x H189 x sp. 20
4 - L 101 x H189 x sp. 20

L02_AR01

L01_AR01

AR01

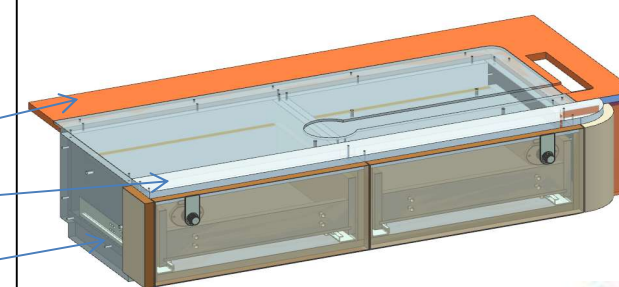

consonni&c

AZ68F

DA MAT. 203 REV. 29-04-2024

LOCALE	CODICE	DESCRIZIONE COMPONENTE	FINITURA	Q.TA	OPERATORE
CABINA ARMATORE	AZ68F-L01_AR01	COMODINO POPPA	LACCATO BIANCO ARTICO	1	Damiano



+FACCIA SOTTO

ELEMENTO DA MONTARE con:
R01_AR01
AR01
L02_AR01
e spedire con un unico imballo

1 - L 1023 x H.81 x sp 32

* faccia dove viene applicata la finitura
↓
filo dove viene applicata la finitura

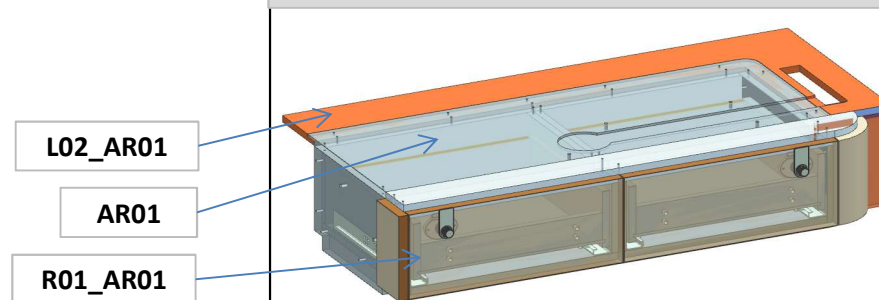

consonni&c

AZ68F

DA MAT. 203 REV. 29-04-2024

LOCALE	CODICE	DESCRIZIONE COMPONENTE	FINITURA	Q.TA	OPERATORE
CABINA ARMATORE	AZ68F-L02_AR01	COMODINO POPPA	LACCATO BRONZO	3	Damiano

* faccia dove viene applicata la finitura
 ↓ filo dove viene applicata la finitura

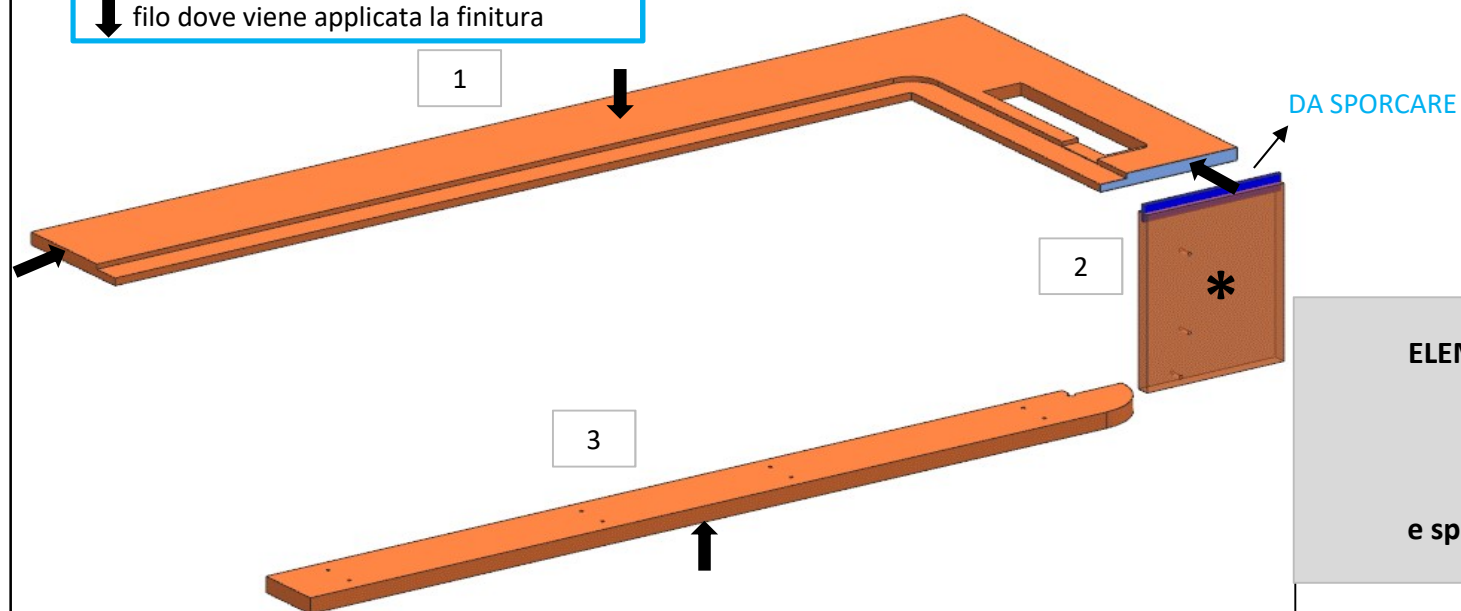

ELEMENTO DA MONTARE con:
 R01_AR01
 L01_AR01
 AR01
 e spedire con un unico imballo

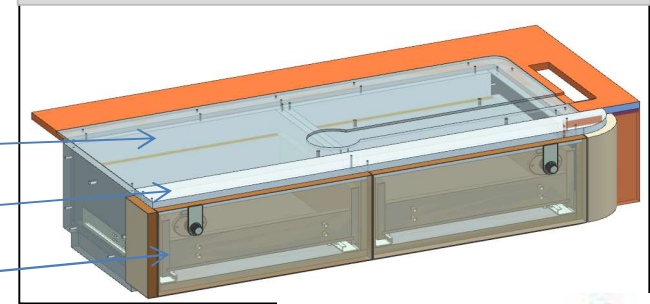

- 1 - L 1105 x H.468 x sp 15
- 2 - L 162 x H.208 x sp 15
- 3 - L 1003 x H.76 x sp 19

- AR01
- L01_AR01
- R01_AR01

AZ68F

REV. 29-04-2024

LOCALE	CODICE	DESCRIZIONE COMPONENTE	FINITURA	Q.TA	OPERATORE
CABINA ARMATORE	AZ68F-MF_AS01	COMODINO PRUA			Damiano

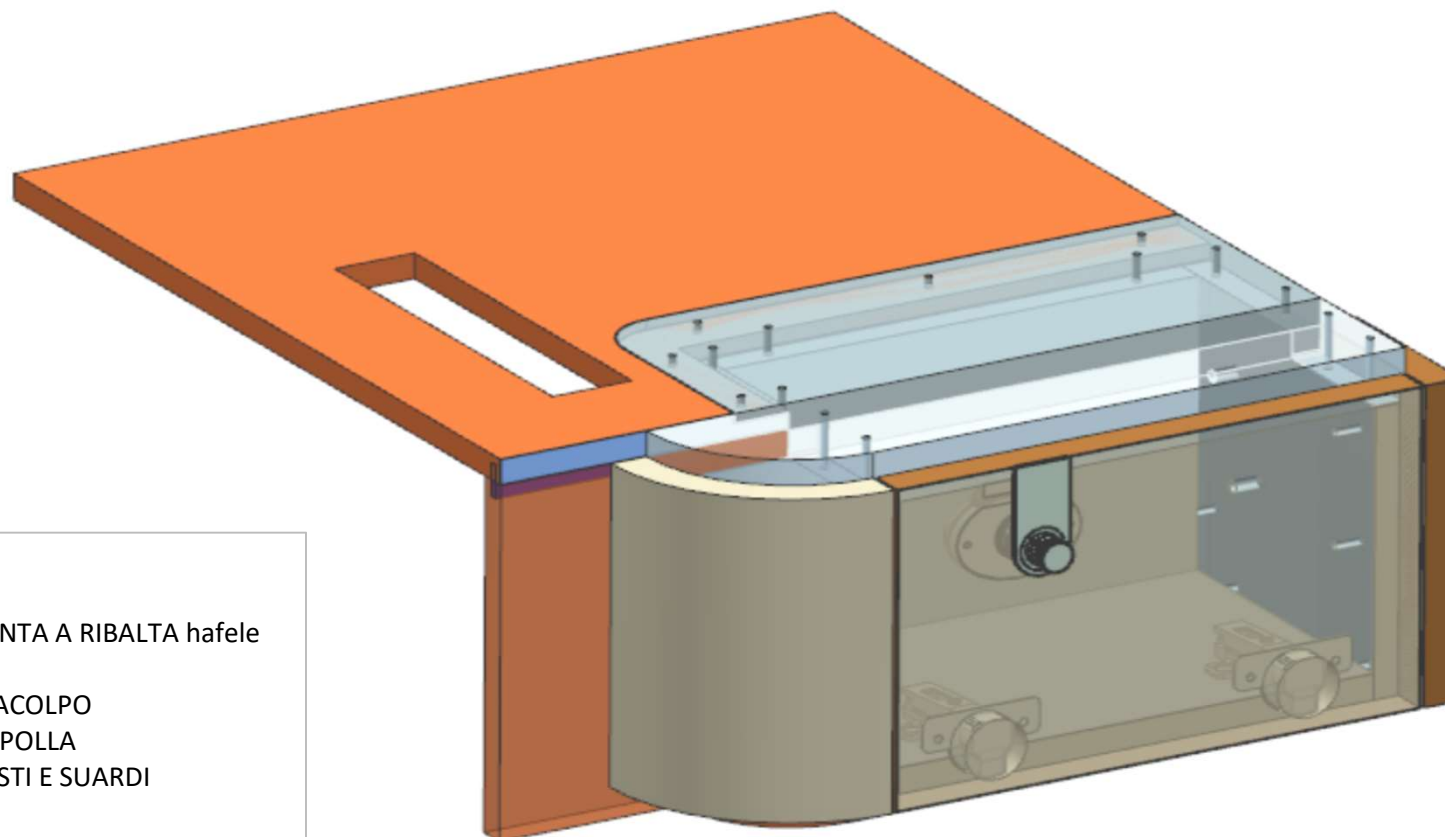

FERRAMENTA:

- N° 2 - CERNIERA PER ANTA A RIBALTA hafele 342.66.730
- N° 2 - GOMMINO PARACOLPO
- N° 1 - BRACCETTO A CIPOLLA
- N° 1 - MANIGLIA FORESTI E SUARDI
- N° 2 - VITI 6MA

AZ68F

DA MAT. 233 REV. 29-04-2024

LOCALE	CODICE	DESCRIZIONE COMPONENTE	FINITURA	Q.TA	OPERATORE
CABINA ARMATORE	AZ68F-AS01	COMODINO PRUA	LAMINATO NADIR	1	Damiano

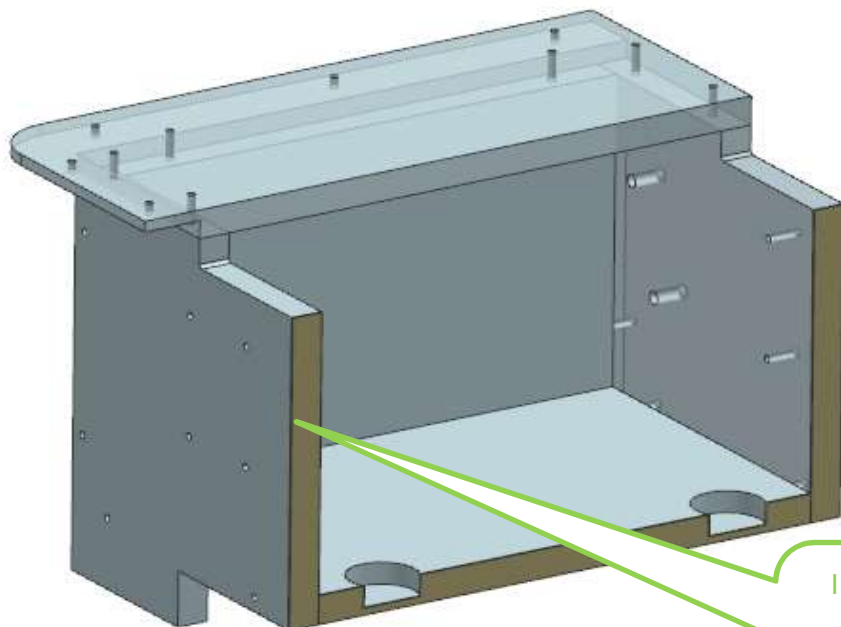

INSERIRE SULLA
SPALLA SX
BRACCETTO A
CIPOLLA

FERRAMENTA:

- N° 2 - CERNIERA PER ANTA A RIBALTA hafele 342.66.730
- N° 2 - GOMMINO PARACOLPO
- N° 1 - BRACCETTO A CIPOLLA
- N° 1 - MANIGLIA FORESTI E SUARDI
- N° 2 - VITI 6MA

ELEMENTO DA MONTARE con:

R01_AS01

L01_AS01

L02_AS01

e spedire con un unico imballo

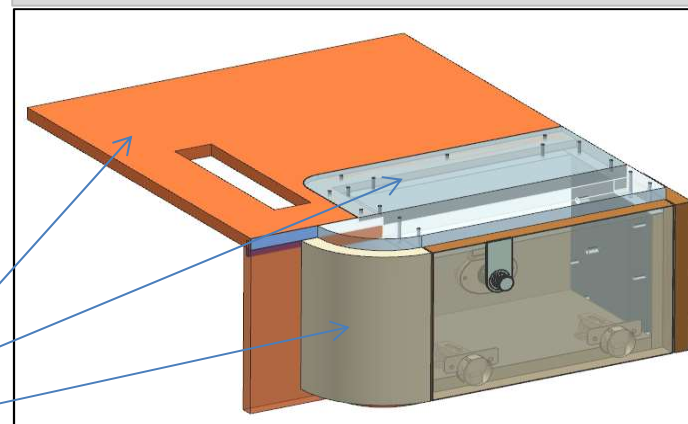

L02_AS01

L01_AS01

R01_AS01

AZ68F

REV. 29-04-2024

LOCALE	CODICE	DESCRIZIONE COMPONENTE	FINITURA	Q.TA	OPERATORE
CABINA ARMATORE	AZ68F-R01_AS01	COMODINO PRUA	LASTRA CHIARA	3	Damiano

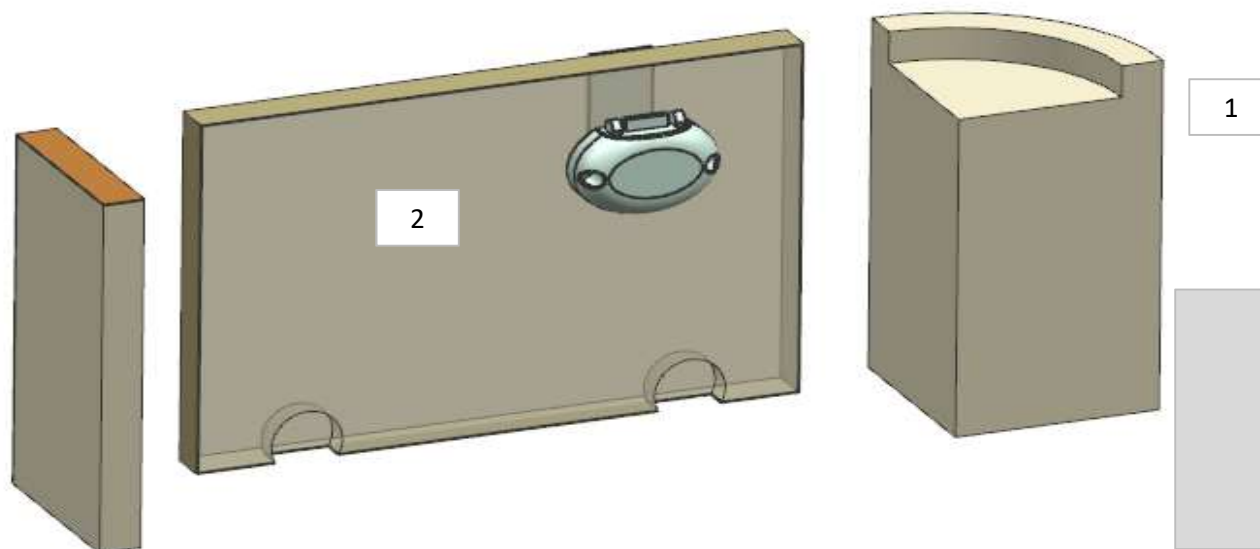

3

- 1 - L 100 x H189 x 101
- 2 - L 295 x H189 x sp. 20
- 3 - L 101 x H189 x sp. 20

ELEMENTO DA MONTARE con:
AS01
L01_AS01
L02_AS01
e spedire con un unico imballo

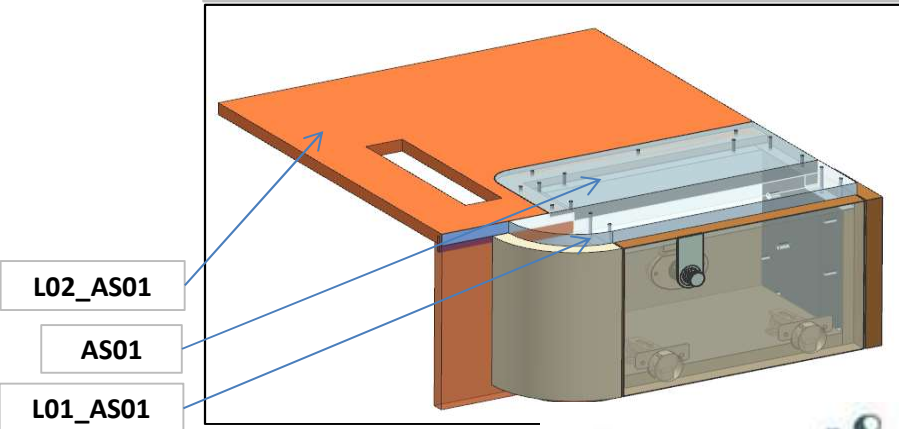

AZ68F

DA MAT. 203 REV. 29-04-2024

LOCALE	CODICE	DESCRIZIONE COMPONENTE	FINITURA	Q.TA	OPERATORE
CABINA ARMATORE	AZ68F-L01_AS01	COMODINO PRUA	LACCATO BIANCO ARTICO	1	Damiano



+FACCIA SOTTO

ELEMENTO DA MONTARE con:
R01_AS01
AS01
L02_AS01
e spedire con un unico imballo

1 - L.380 x H 81 x sp 32

* faccia dove viene applicata la finitura

↓ filo dove viene applicata la finitura

L02_AS01

AS01

R01_AS01

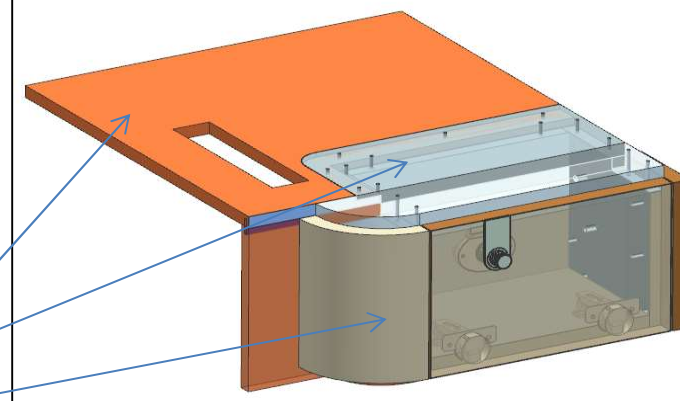

consonni&c

AZ68F

DA MAT. 203 REV. 29-04-2024

LOCALE	CODICE	DESCRIZIONE COMPONENTE	FINITURA	Q.TA	OPERATORE
CABINA ARMATORE	AZ68F-L02_AS01	COMODINO PRUA	LACCATO BRONZO	3	Damiano

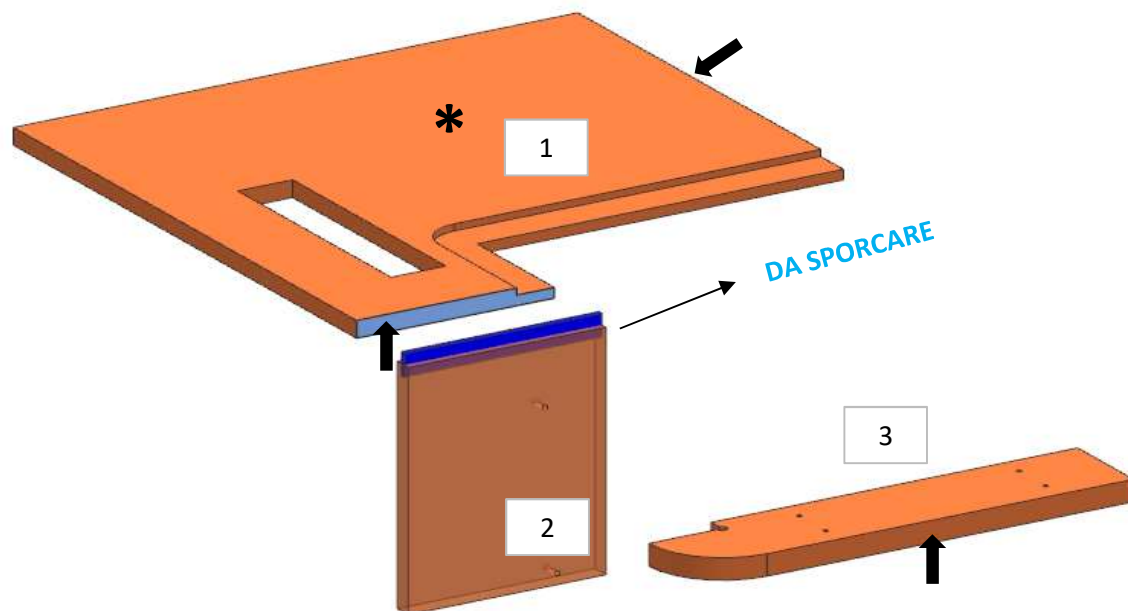

ELEMENTO DA MONTARE con:
R01_AS01
AS01
L01_AS01
 e spedire con un unico imballo

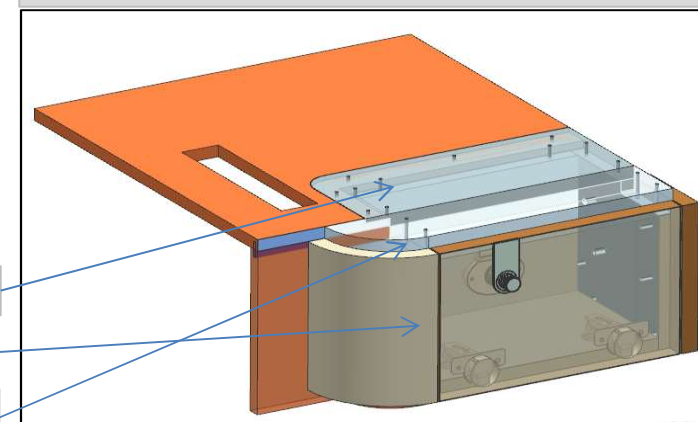

- 1 - L.462 x H.468 x sp 15
- 2 - L.162 x H.208 x sp 15
- 3 - L.360 x H.76 x sp 19

* faccia dove viene applicata la finitura
 ↓ filo dove viene applicata la finitura

- AS01
- R01_AS01
- L01_AS01

AZ68F

DA MAT. 216 REV. 29-04-2024

LOCALE	CODICE	DESCRIZIONE COMPONENTE	FINITURA	Q.TA	OPERATORE
CABINA ARMATORE	AZ68F-AW01	PREDELLINO ASCIUGARTICE OPT	LAMINATO NADIR	1	Dante

1 - L 550 x H 200 x pr. 300mm

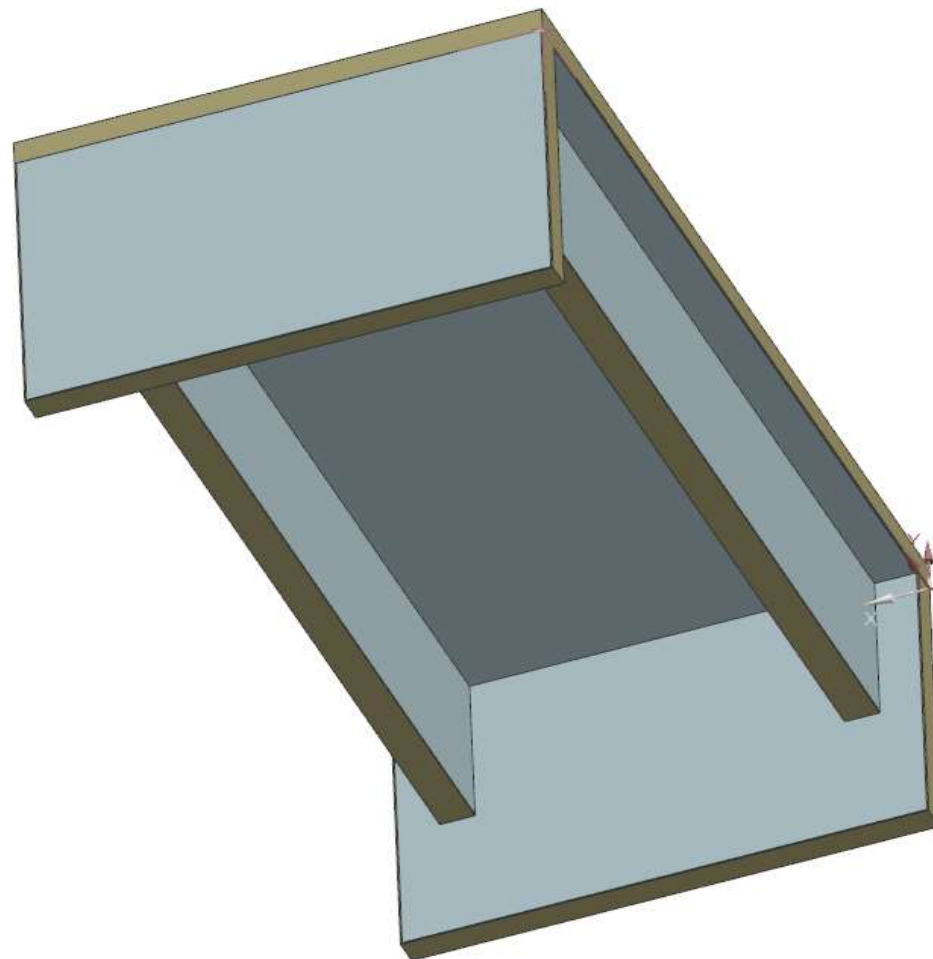

AZ68F

REV. 29-04-2024

LOCALE	CODICE	DESCRIZIONE COMPONENTE	FINITURA	Q.TA	OPERATORE
CABINA ARMATORE	AZ68F-MF_AAR01	COMODINO POPPA OPT			Damiano

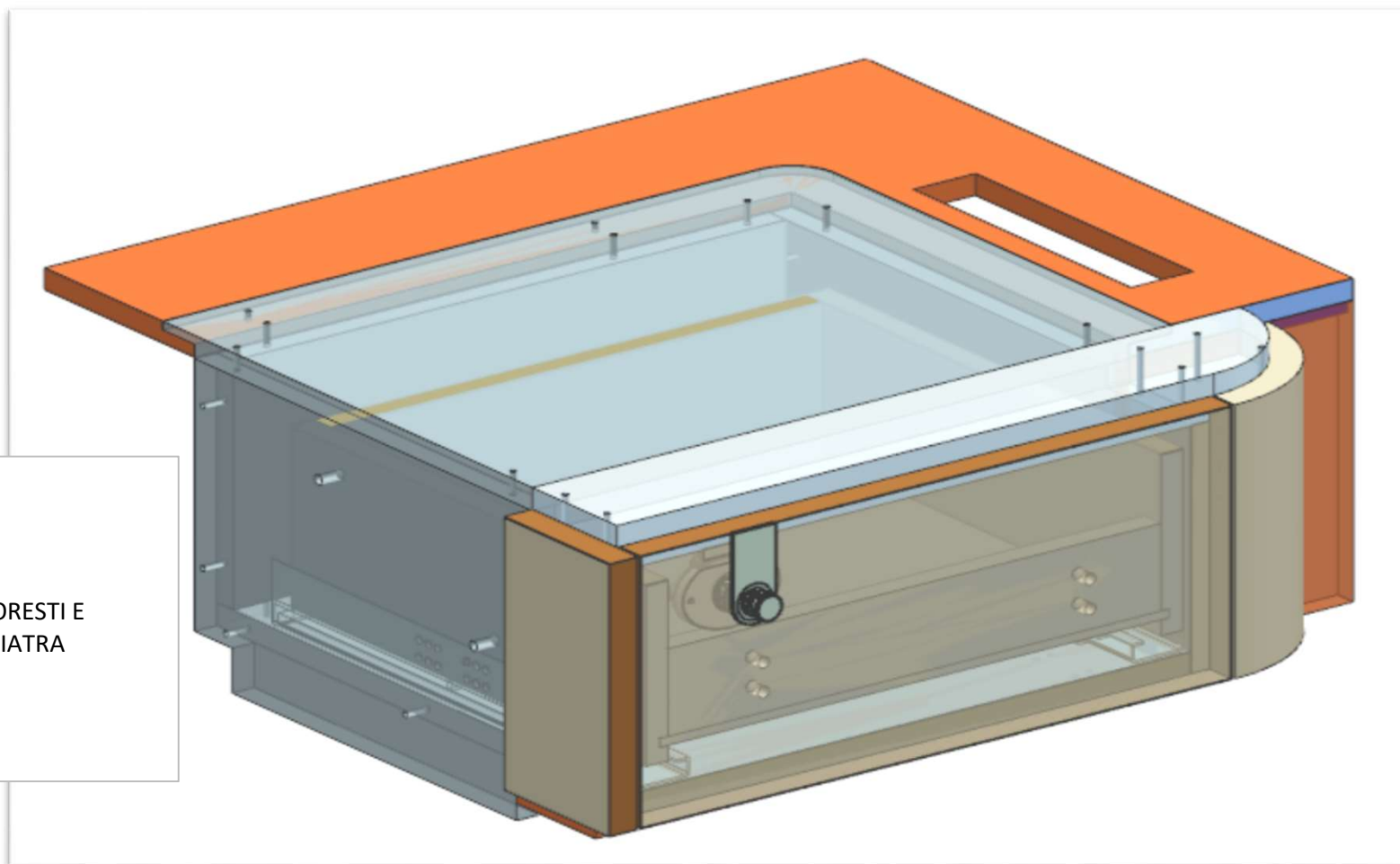

FERRAMENTA:

- N° 1 - GUIDA 350
- N° 8 - VITI 6MA
- N° 1 - KIT MANIGLIA FORESTI E SUARDI CABINA CON PIATRA RETTANGOLARE

AZ68F

DA MAT. 203 REV. 29-04-2024

LOCALE	CODICE	DESCRIZIONE COMPONENTE	FINITURA	Q.TA	OPERATORE
CABINA ARMATORE	AZ68F-AAR01	COMODINO POPPA OPT	LAMINATO NADIR	1	Damiano

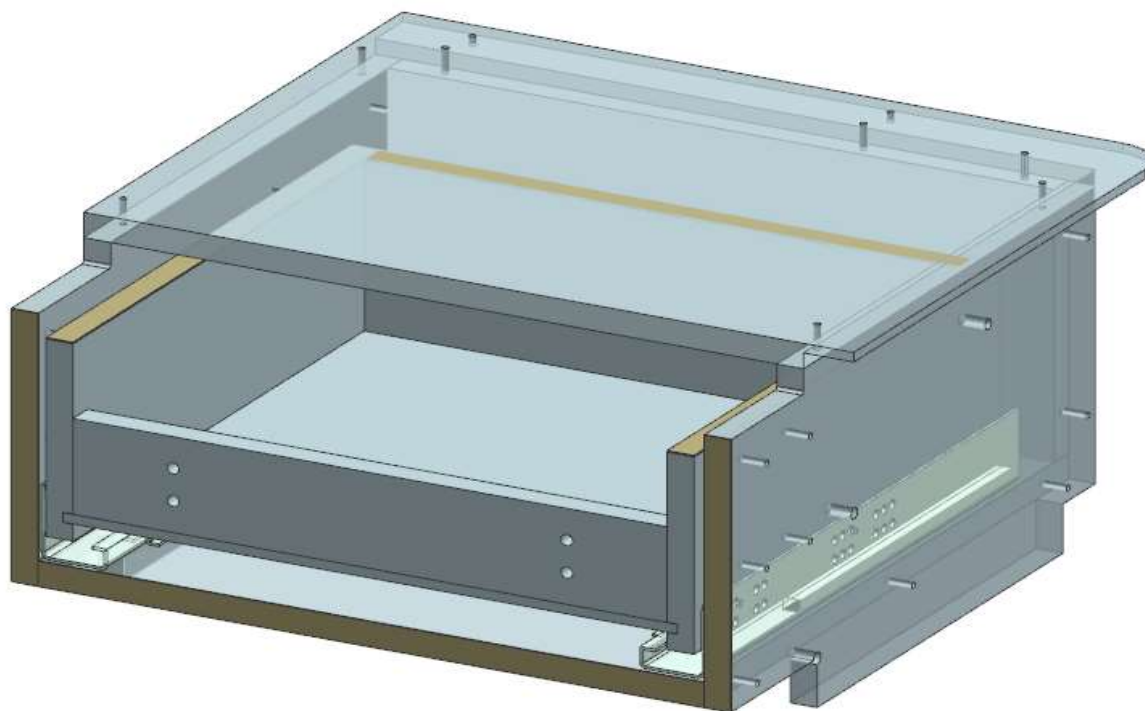

ELEMENTO DA MONTARE con:
R01_AAR01
L01_AAR01
L02_AAR01
e spedire con un unico imballo

L01_AAR01

L02_AAR01

R01_AAR01

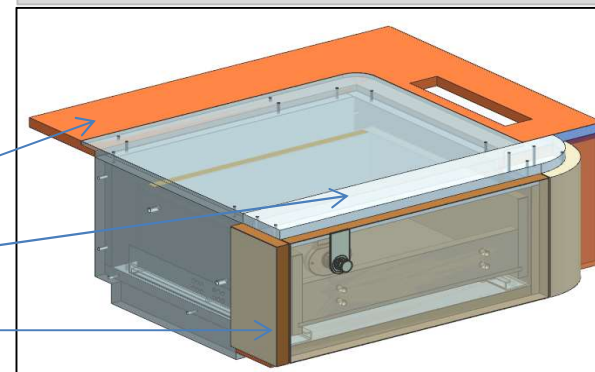

AZ68F

DA MAT. 233 REV. 29-04-2024

LOCALE	CODICE	DESCRIZIONE COMPONENTE	FINITURA	Q.TA	OPERATORE
CABINA ARMATORE	AZ68F-R01_AAR01	COMODINO POPPA OPT	LASTRA CHIARA	3	Damiano

1

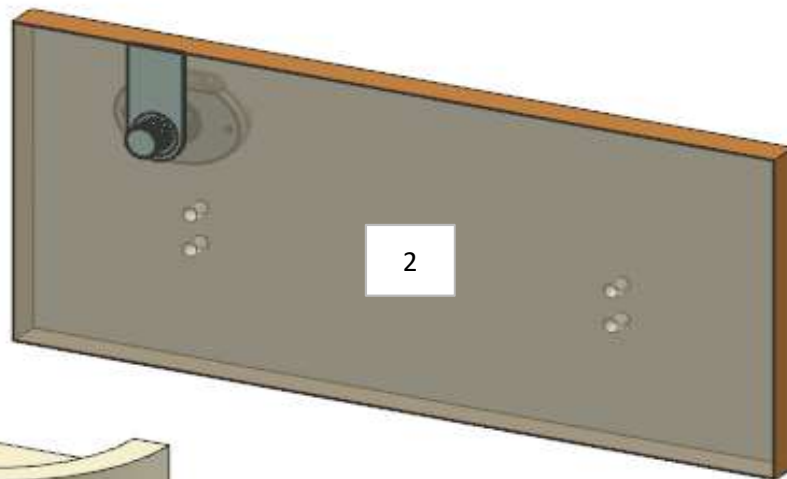
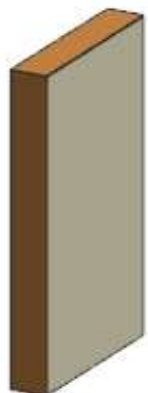

2

1 - L 101 x H 189 x sp 20
2 - L 426 x H 189 x sp 20
3 - L 158 x H 189 x 100

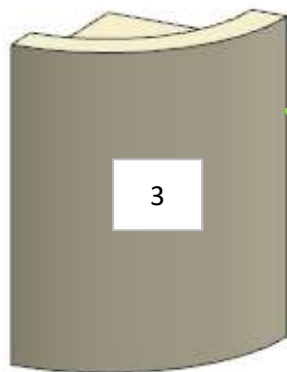

3

COMPOSTO DA PIÙ STRATI DI MDF (16mm + 5pz da 30 mm + 23mm) DA INCOLLARE E RIVESTIRE IN LASTRA SUPPORTATA

ELEMENTO DA MONTARE con:
AAR01
L01_AAR01
L02_AAR01
e spedire con un unico imballo

L01_AAR01

L02_AAR01

AAR01

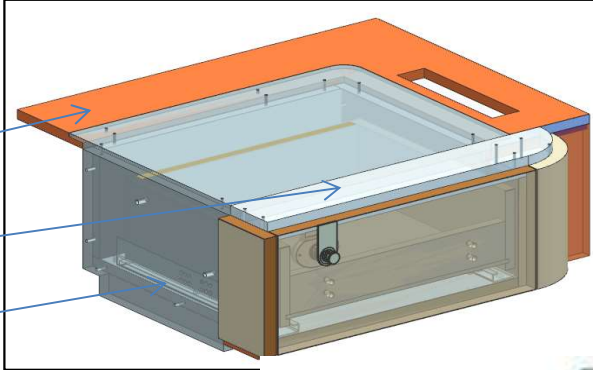

AZ68F

DA MAT. 203 REV. 29-04-2024

LOCALE	CODICE	DESCRIZIONE COMPONENTE	FINITURA	Q.TA	OPERATORE
CABINA ARMATORE	AZ68F-L01_AAR01	COMODINO POPPA OPT	LACCATO BIANCO ARTICO	1	Damiano

1 - L 510 x H 81 x sp 32

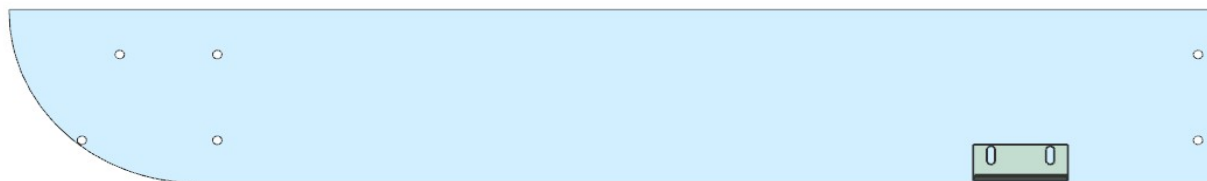

ELEMENTO DA MONTARE con:
R01_AAR01
AAR01
L02_AAR01
e spedire con un unico imballo

AAR01

L02_AAR01

R01_AAR01

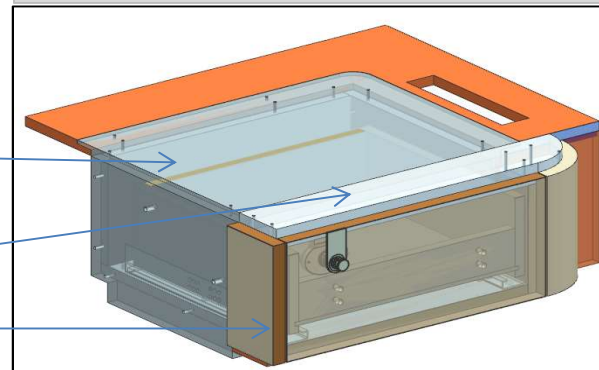

consonni&c

AZ68F

DA MAT. 203 REV. 29-04-2024

LOCALE	CODICE	DESCRIZIONE COMPONENTE	FINITURA	Q.TA	OPERATORE
CABINA ARMATORE	AZ68F-L02_AAR01	COMODINO POPPA OPT	LACCATO BRONZO	2	Damiano

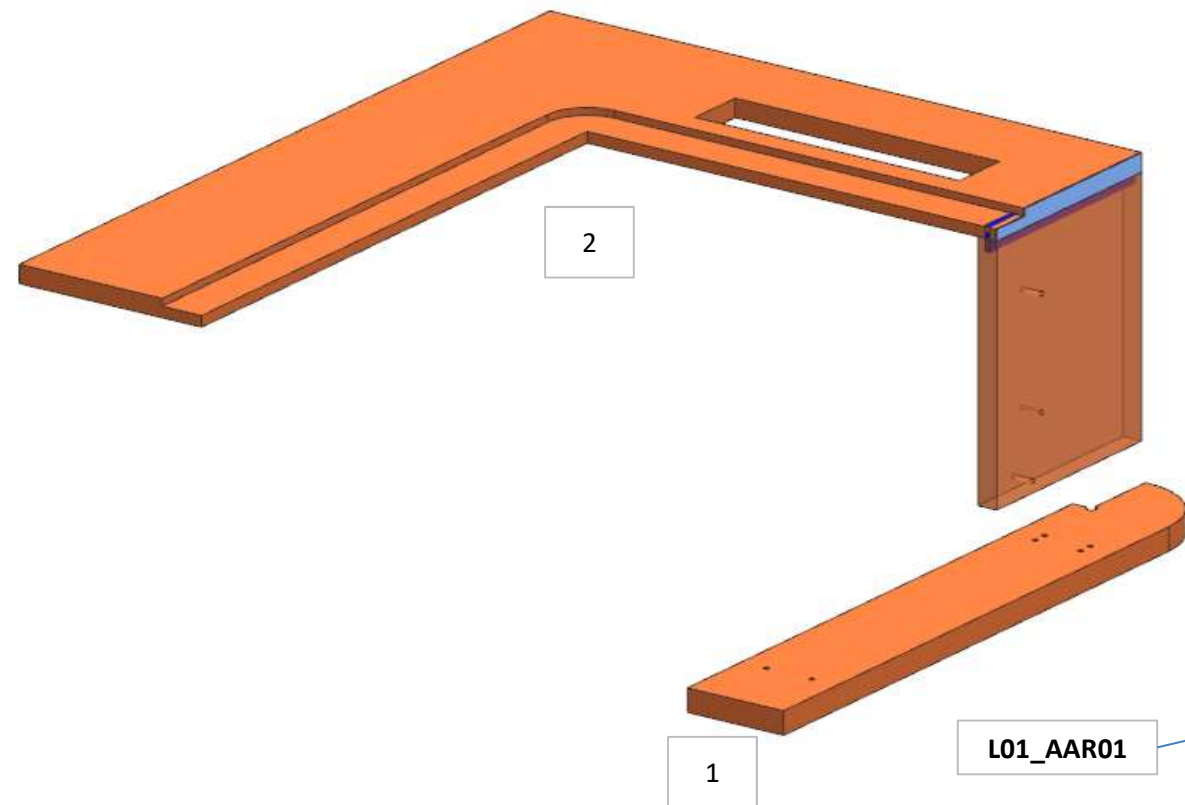

1 - L 490 x H 76 x sp 19
2 - L 592 x H 223 x 468

ELEMENTO DA MONTARE con:
R01_AAR01
L01_AAR01
AAR01
e spedire con un unico imballo

