

LOCALE	CODICE	DESCRIZIONE COMPONENTE	FINITURA	Q.TA
CABINA VIP	MD299_MF_VB01	COMODINI		1

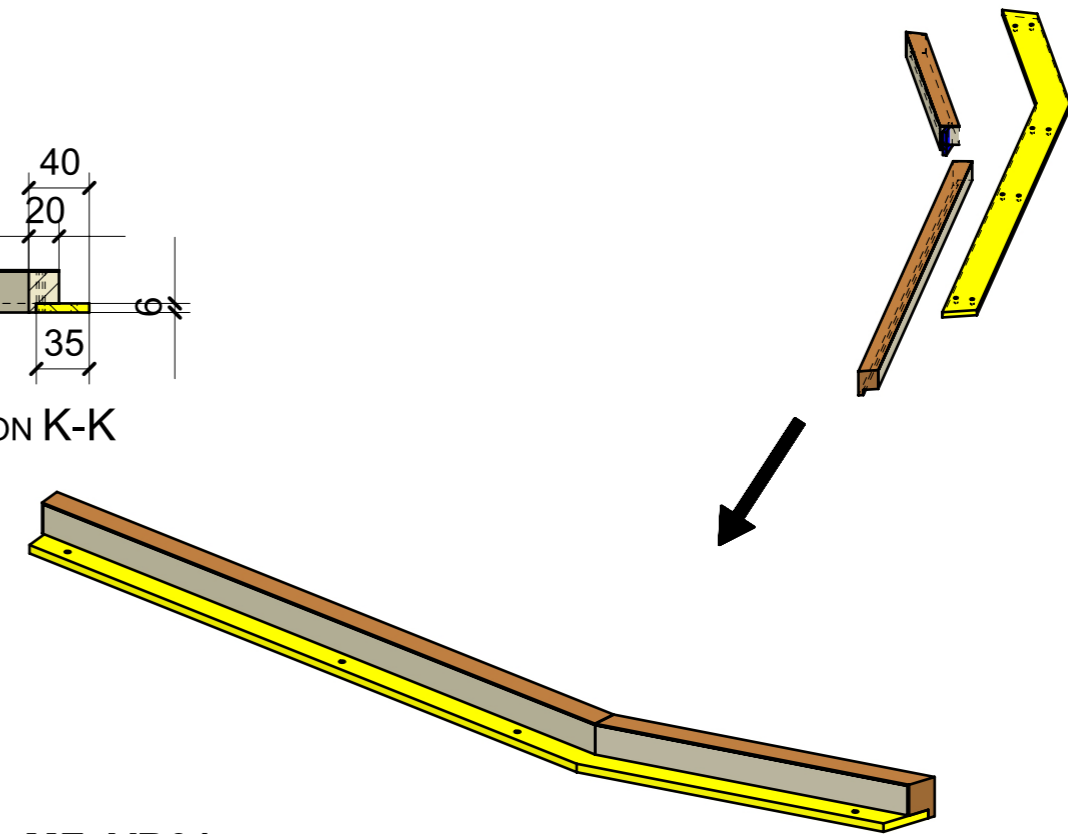

MF_VB01

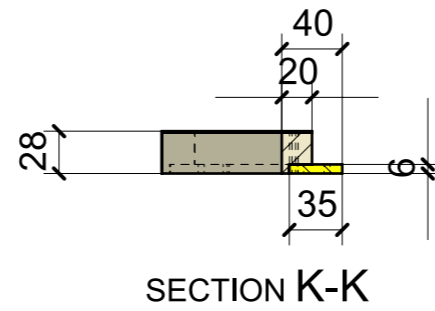
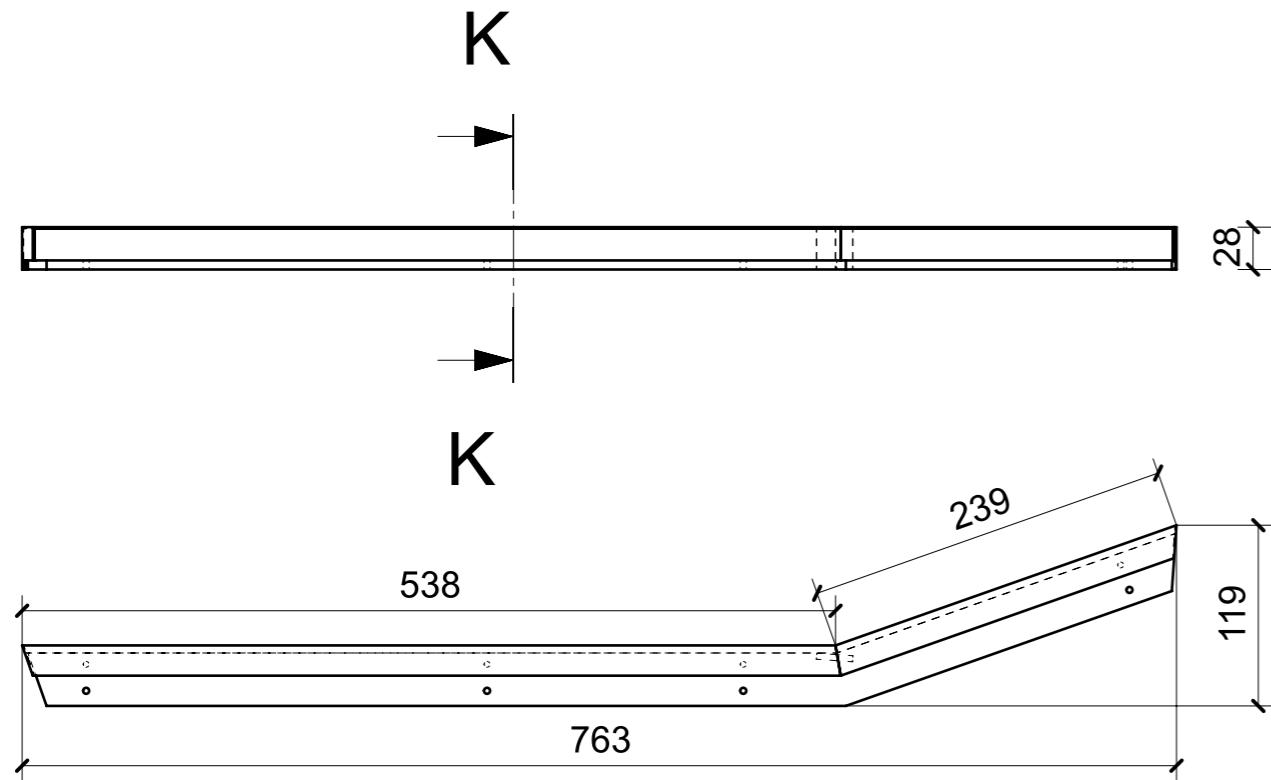
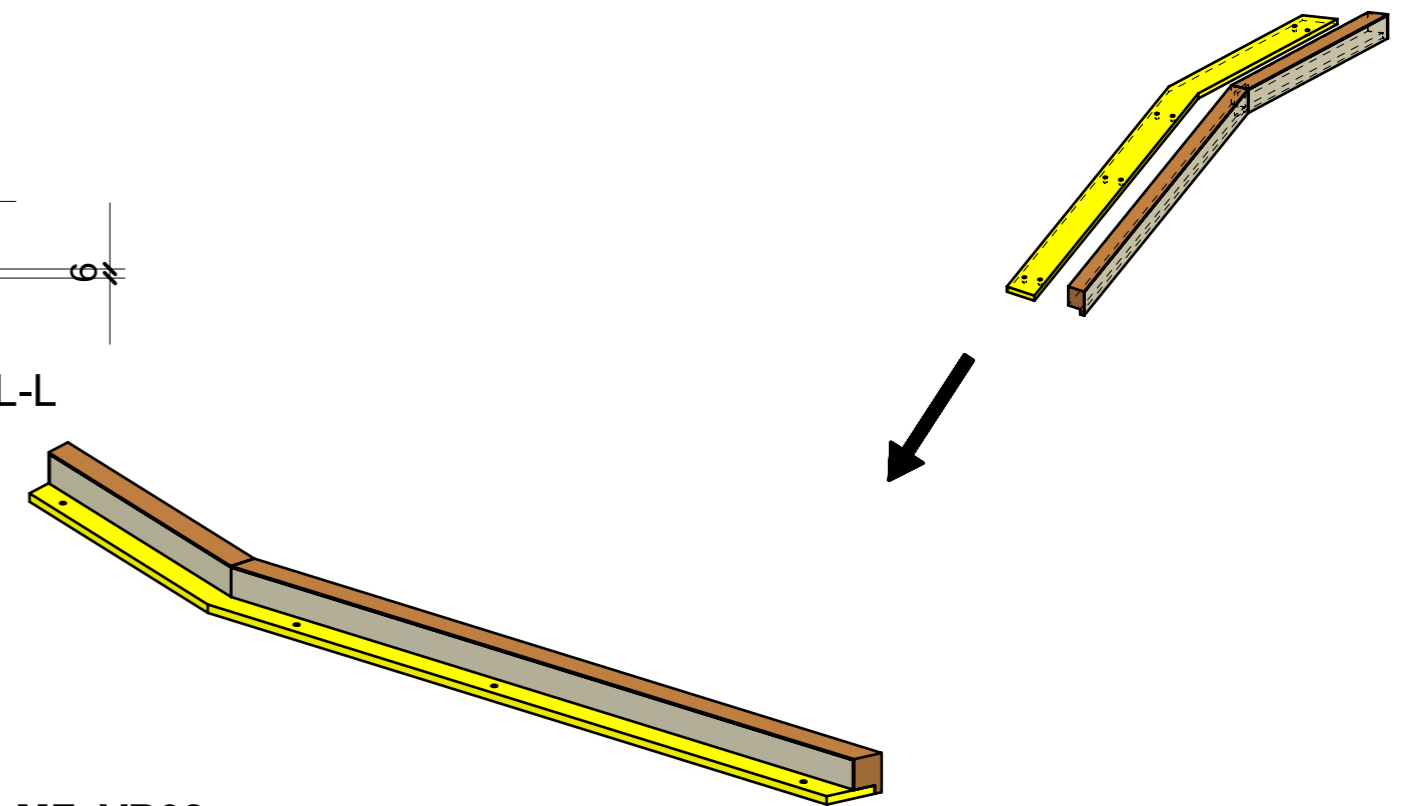
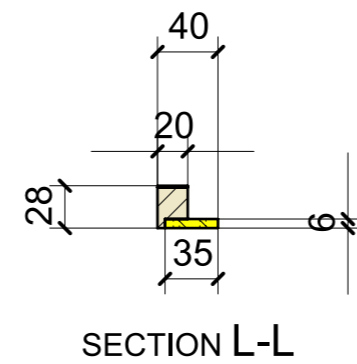
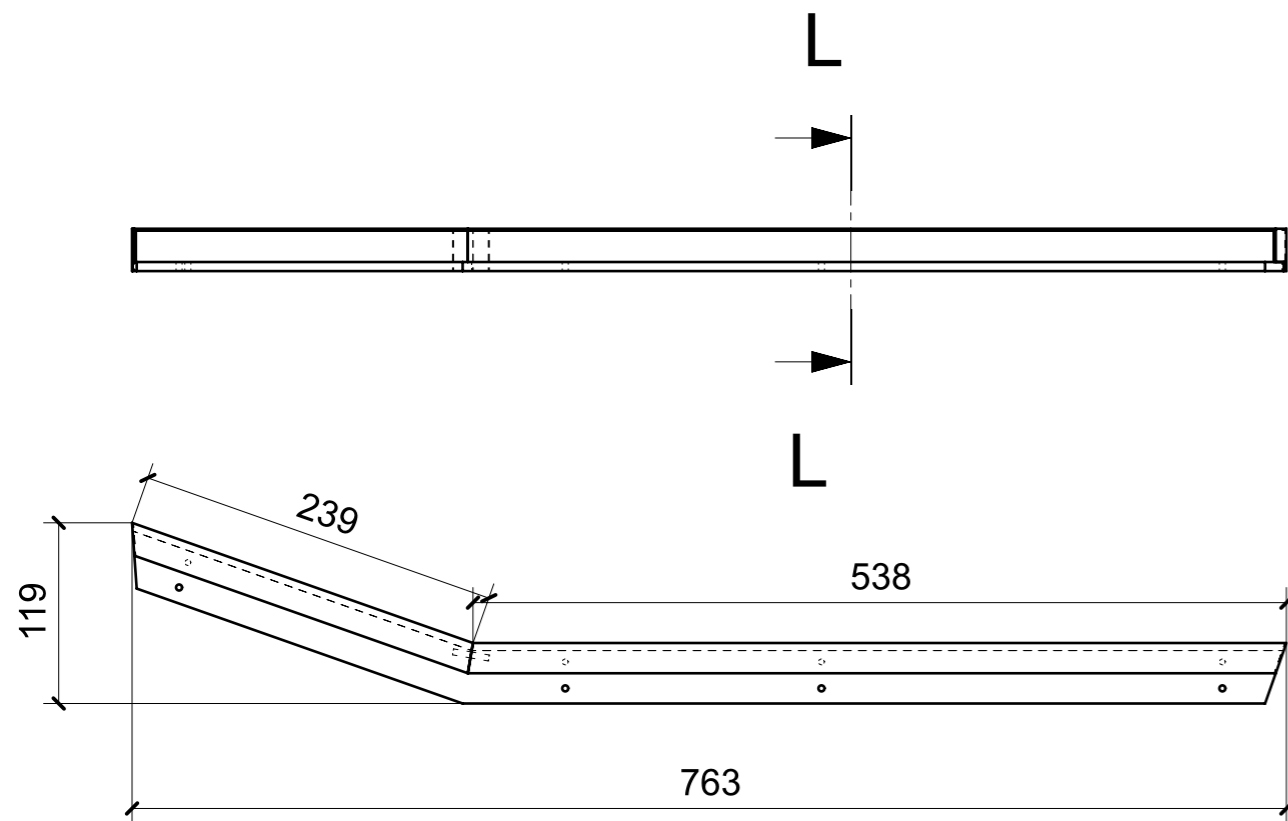

MF_VB02

LOCALE	CODICE	DESCRIZIONE COMPONENTE	FINITURA	Q.TA
CABINA VIP	MD299 MF_VK01	STRUTTURA SOTTO CIELINO PRUA		1

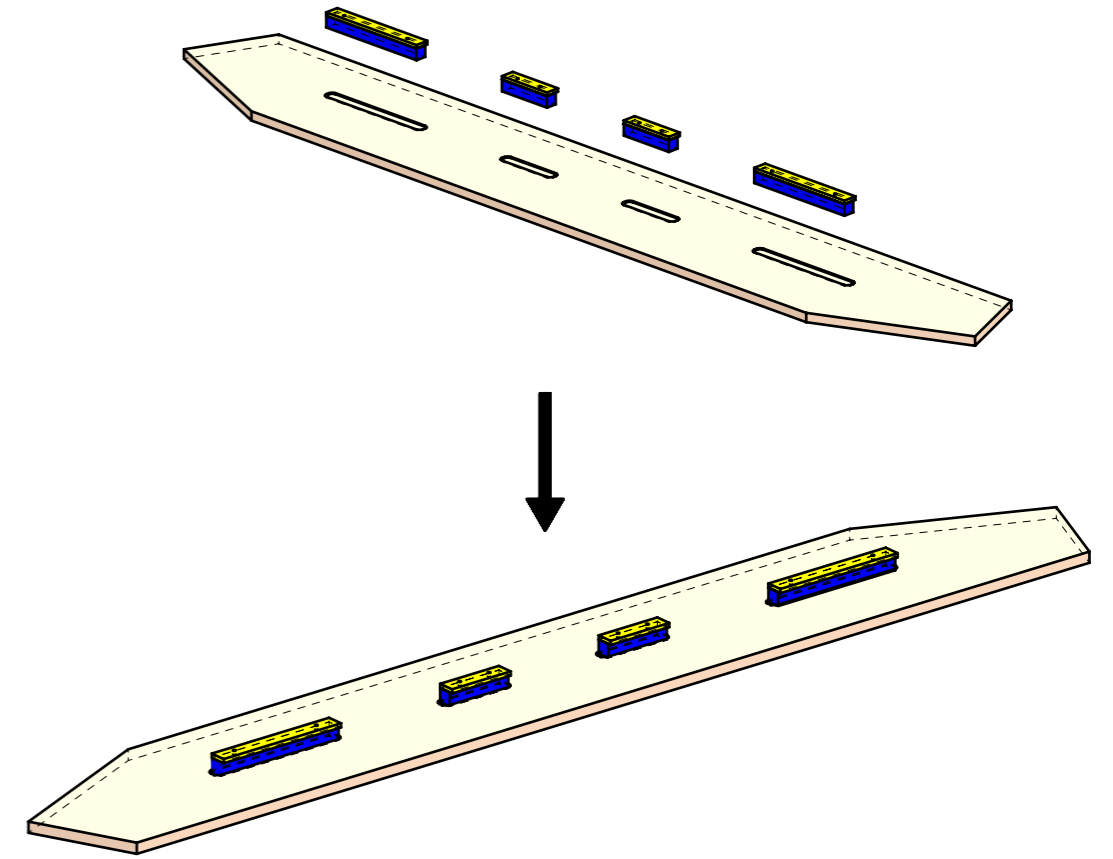
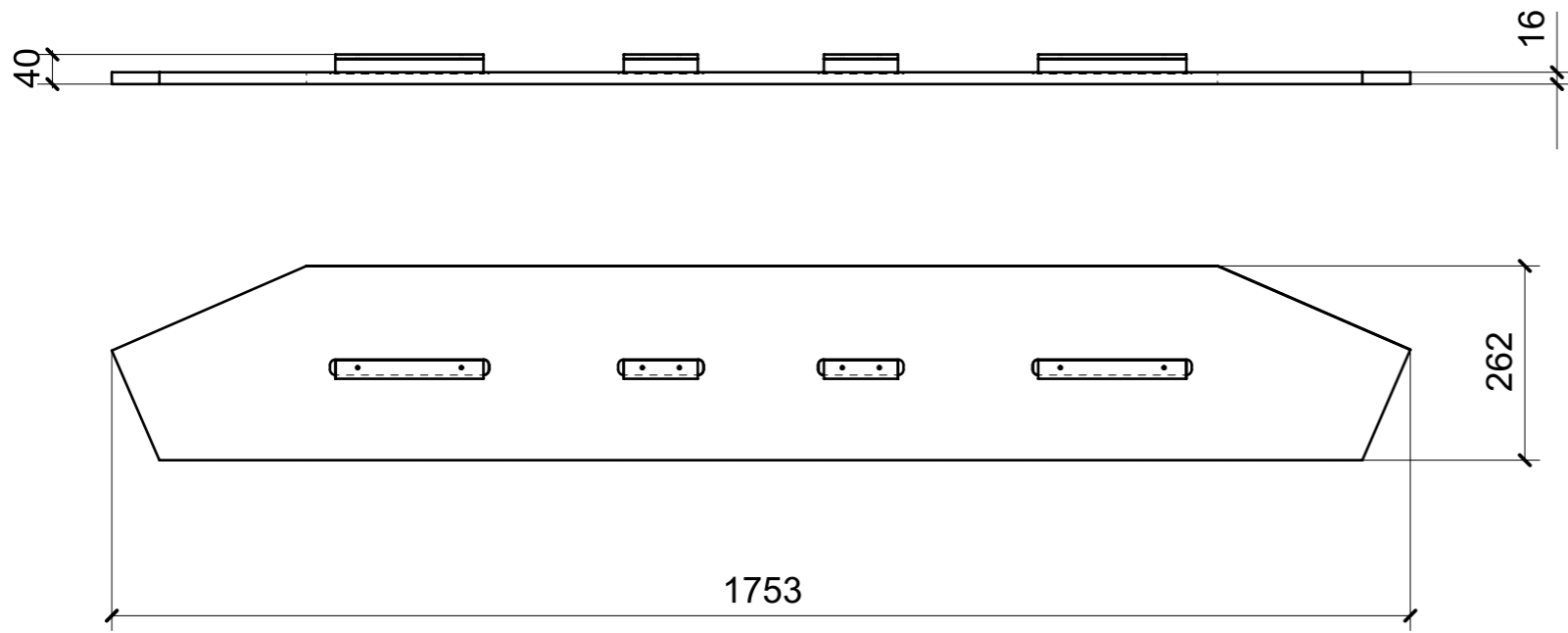

LOCALE	CODICE	DESCRIZIONE COMPONENTE	FINITURA	Q.TA
CABINA VIP	MD299_MF_VQ01	CIELINO		1

MF_VQ01

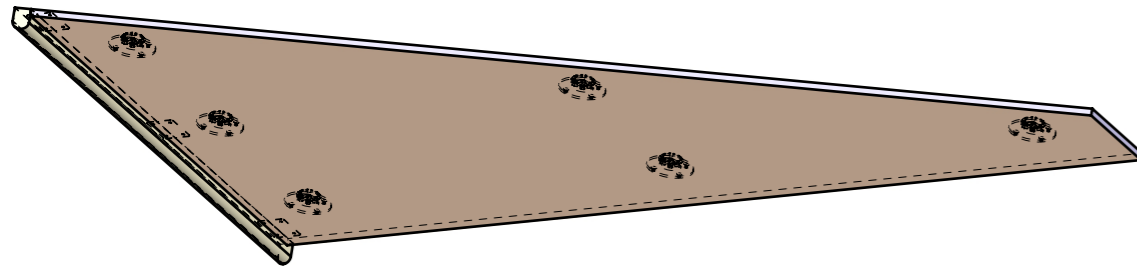

FERRAMENTA	QTY
PIASTRINA SP.1MM 50X40_FBC_ART_264 Z	3
FITLOCK M_MASCHERPA_3MM_6020202101	6

MF_VQ02

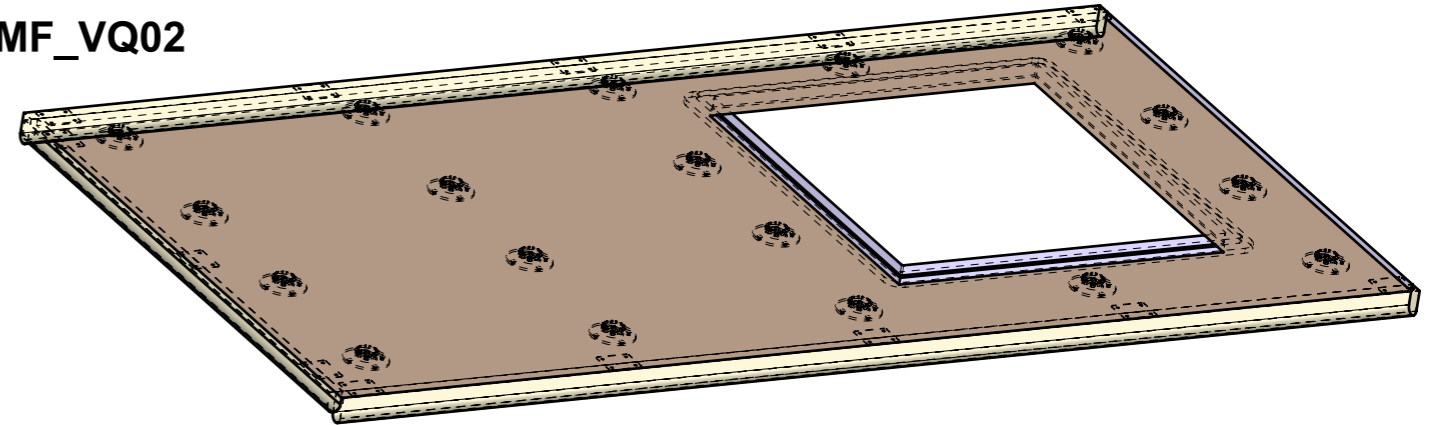

FERRAMENTA	QTY
PIASTRINA SP.1MM 50X40_FBC_ART_264 Z	13
FITLOCK M_MASCHERPA_3MM_6020202101	18

MF_VQ03

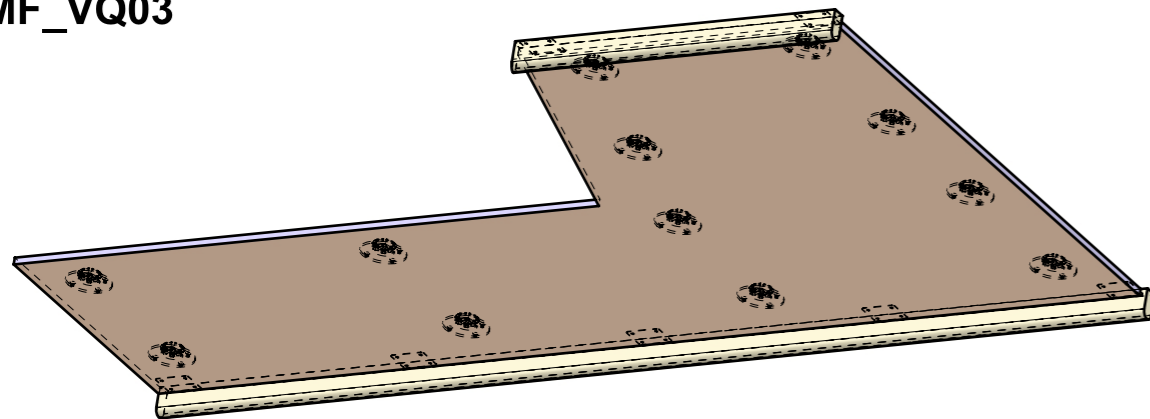

FERRAMENTA	QTY
PIASTRINA SP.1MM 50X40_FBC_ART_264 Z	7
FITLOCK M_MASCHERPA_3MM_6020202101	12

MF_VQ04

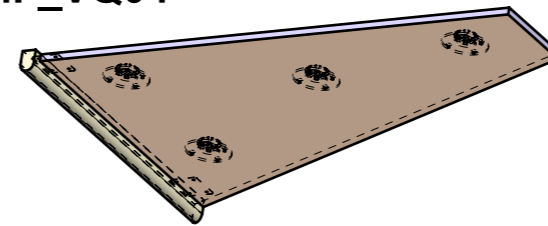

FERRAMENTA	QTY
PIASTRINA SP.1MM 50X40_FBC_ART_264 Z	2
FITLOCK M_MASCHERPA_3MM_6020202101	4

MF_VQ05

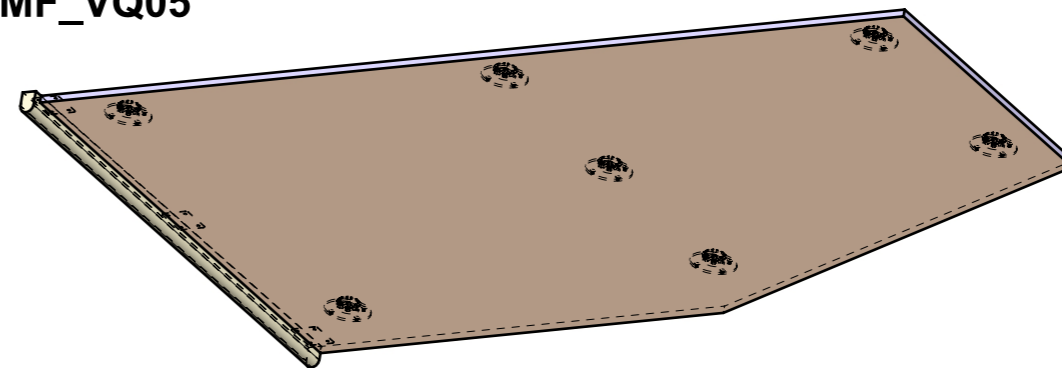

FERRAMENTA	QTY
PIASTRINA SP.1MM 50X40_FBC_ART_264 Z	3
FITLOCK M_MASCHERPA_3MM_6020202101	7