

LOCALE	CODICE	DESCRIZIONE COMPONENTE	FINITURA	Q.TA
CABINA ARMATORE	MD299_L01_AC01	PONTE AC MURATA SX	LACCATO BIANCO 9010	1

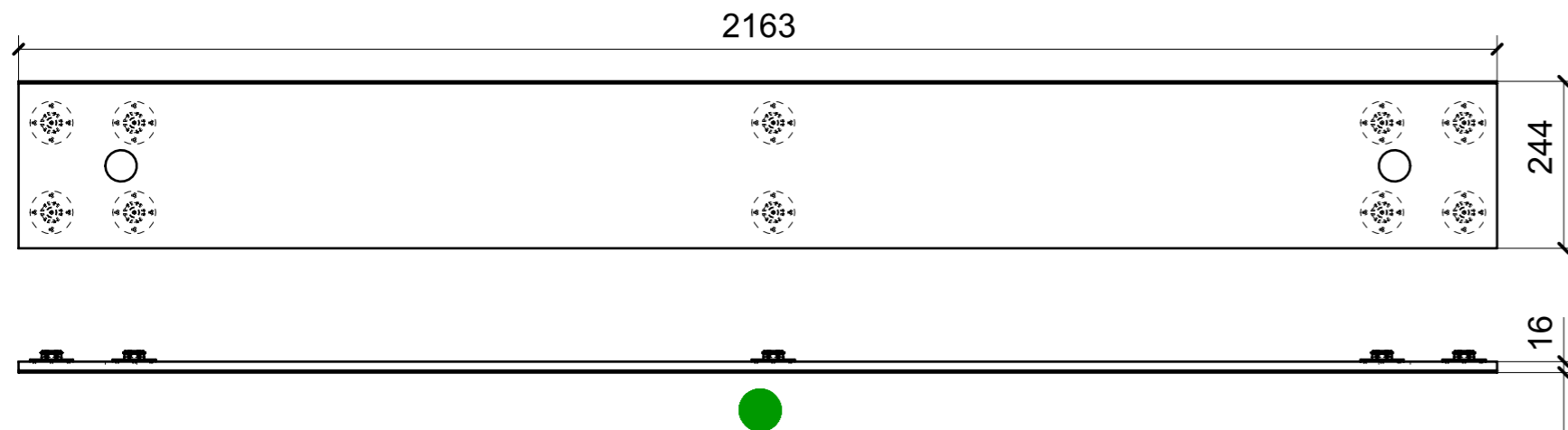
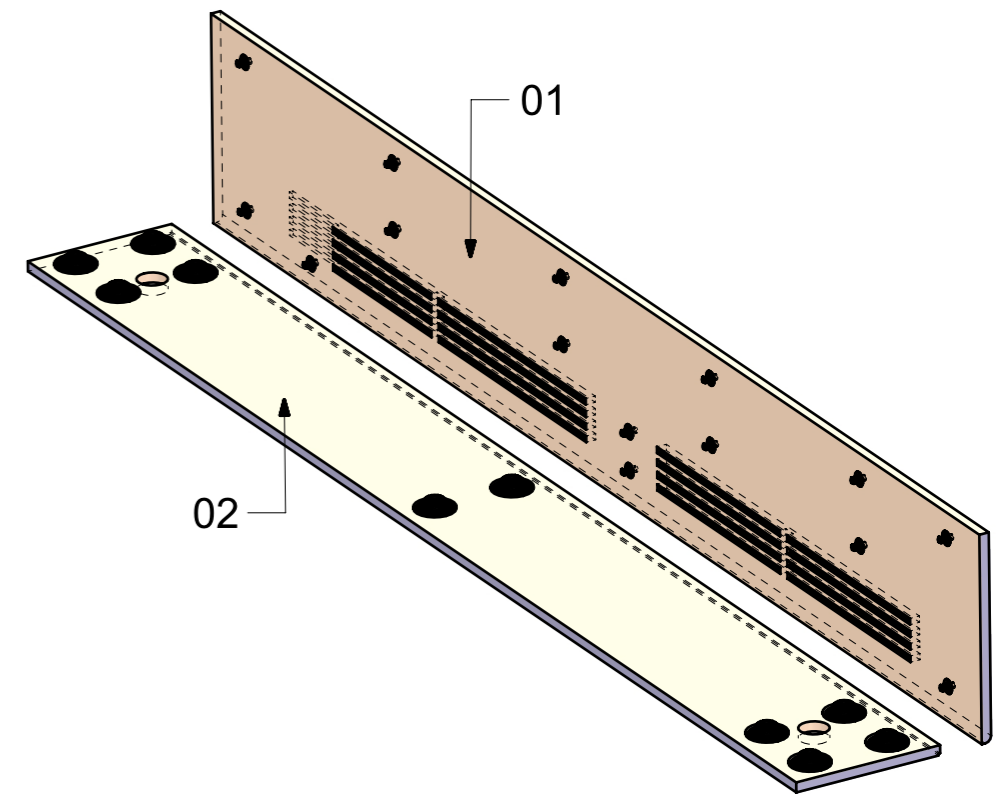
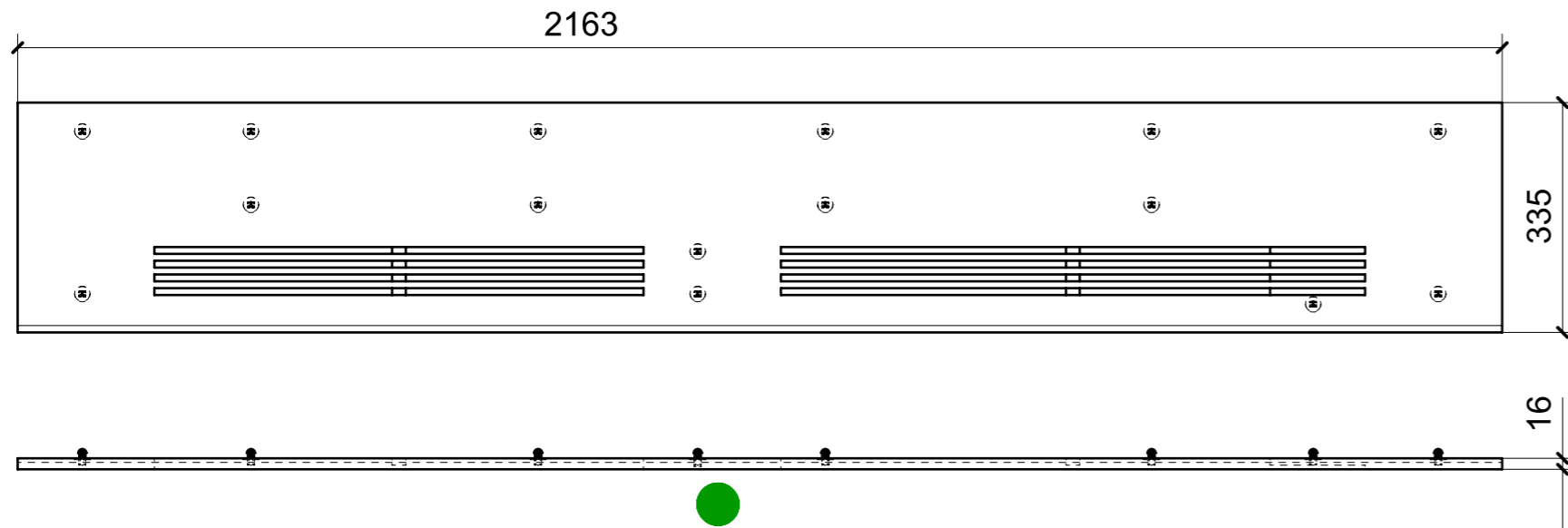

FERRAMENTA	QTY
MS INCASSO_ITALVIPLA_972_FMPC_M1B	15
FITLOCK M_MASCHERPA_3MM_6020202101	10

VERNICIATURA LASTRA/LACCATI:

● = VERNICIARE 1 LATO + FILI RASATI O BORDATI

NESSUN SIMBOLO = VERNICIARE 2 LATI + FILI RASATI O BORDATI

LOCALE	CODICE	DESCRIZIONE COMPONENTE	FINITURA	Q.TA
CABINA ARMATORE	MD299_L01_AI01	PONTE AC MURATA DX	LACCATO BIANCO 9010	1

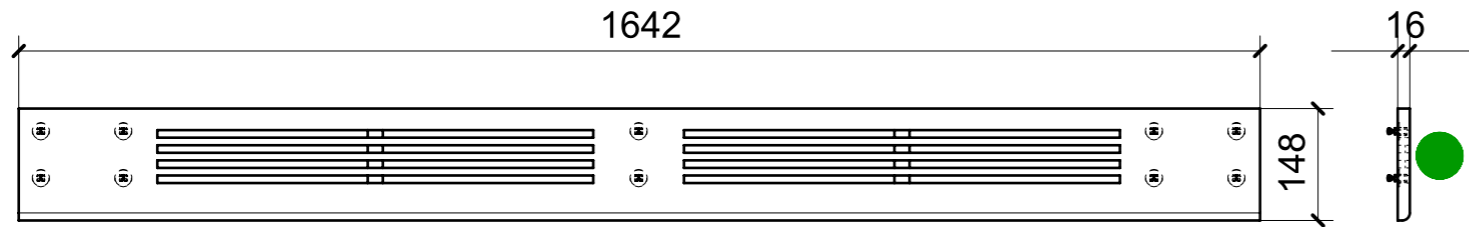

01

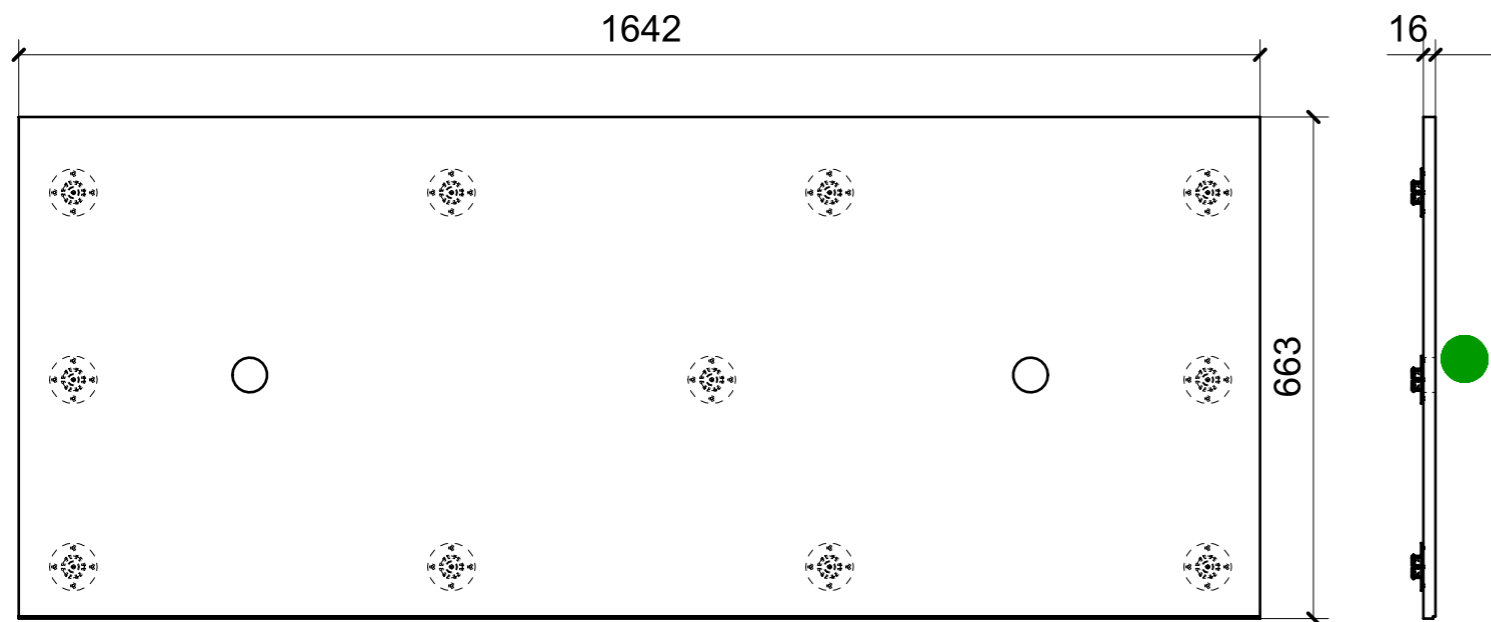
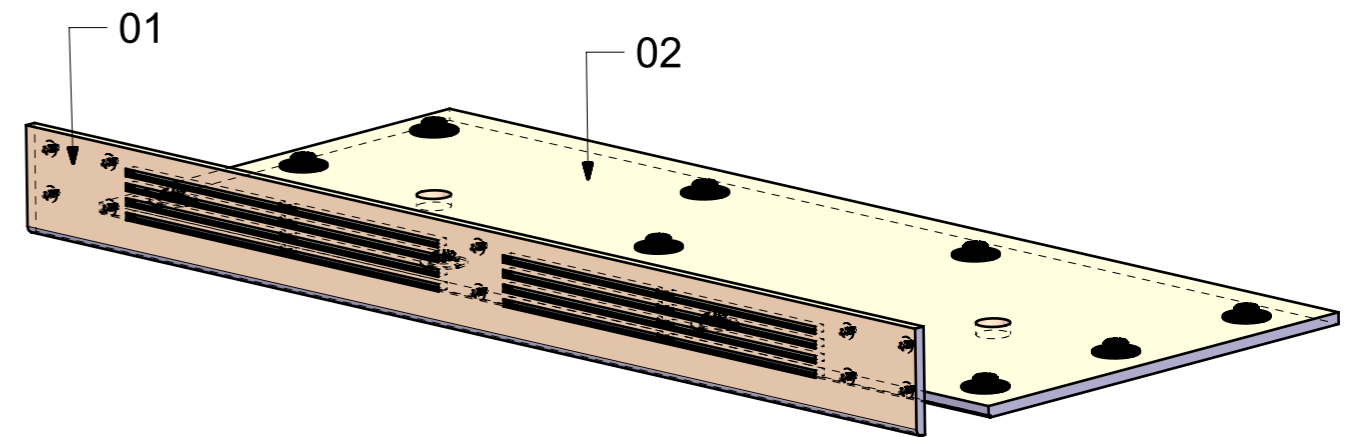

02

FERRAMENTA	QTY
MS INCASSO_ITALVIPLA_972_FMPC_M1B	10
FITLOCK M_MASCHERPA_3MM_6020202101	11

VERNICIATURA LASTRA/LACCATI:

● = VERNICIARE 1 LATO + FILI RASATI O BORDATI

NESSUN SIMBOLO = VERNICIARE 2 LATI + FILI RASATI O BORDATI

LOCALE	CODICE	DESCRIZIONE COMPONENTE	FINITURA	Q.TA
CABINA ARMATORE	MD299_L01_AS01	CIELINO	LACCATO BIANCO 9010	1

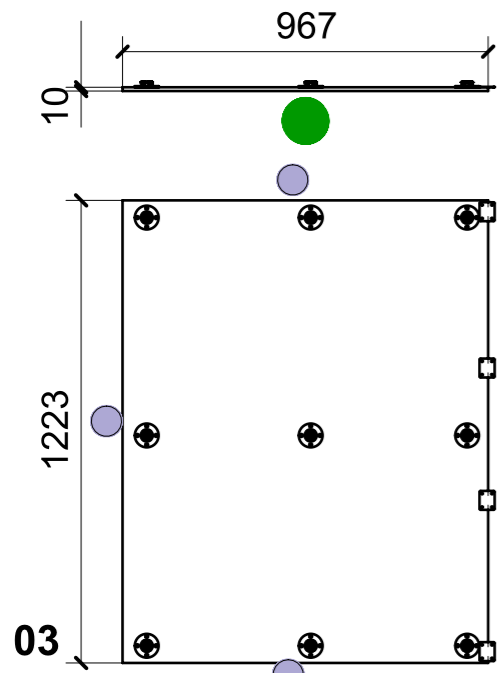

03
ELEMENTO DA MONTARE CON R01_05 IN MF_AS02
e spedire con unico imballo

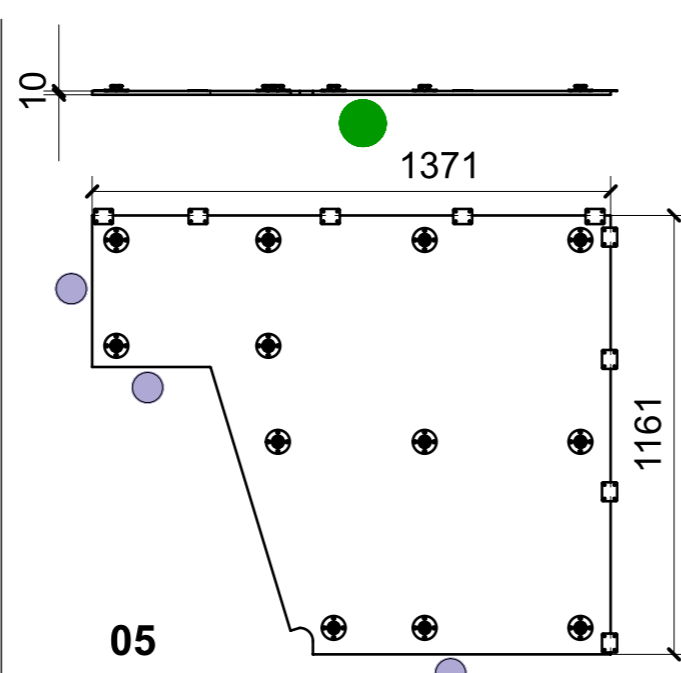
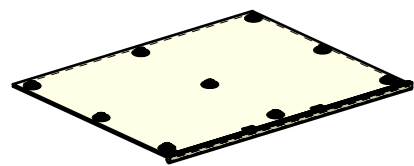

05
ELEMENTO DA MONTARE CON R01_07/08 IN MF_AS04
e spedire con unico imballo

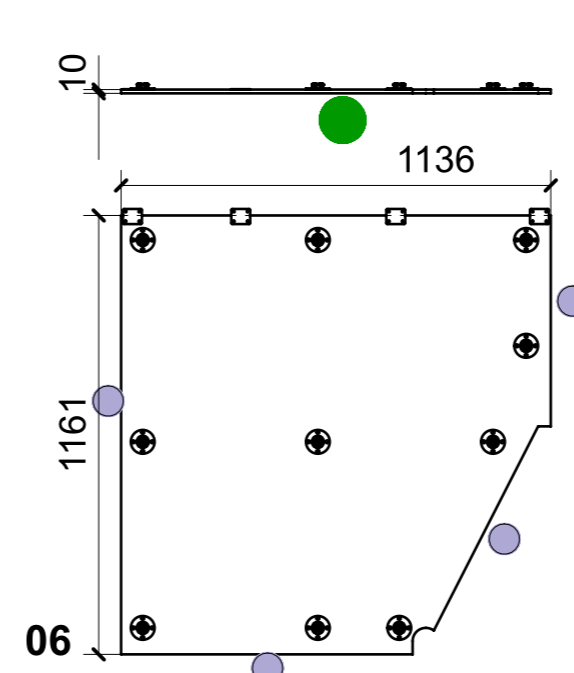
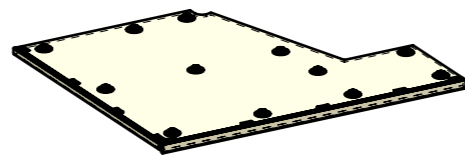

06
ELEMENTO DA MONTARE CON R01_06 IN MF_AS03
e spedire con unico imballo

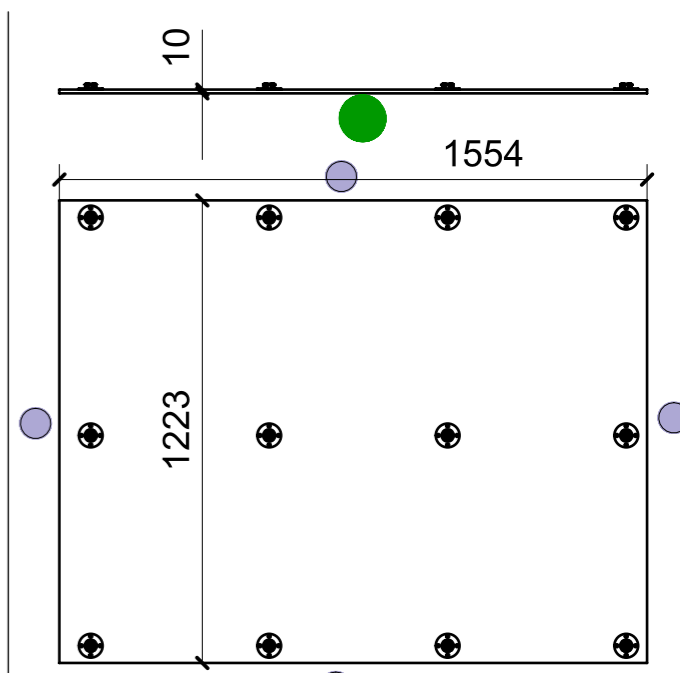
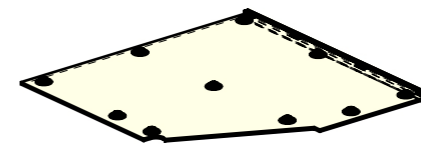

04

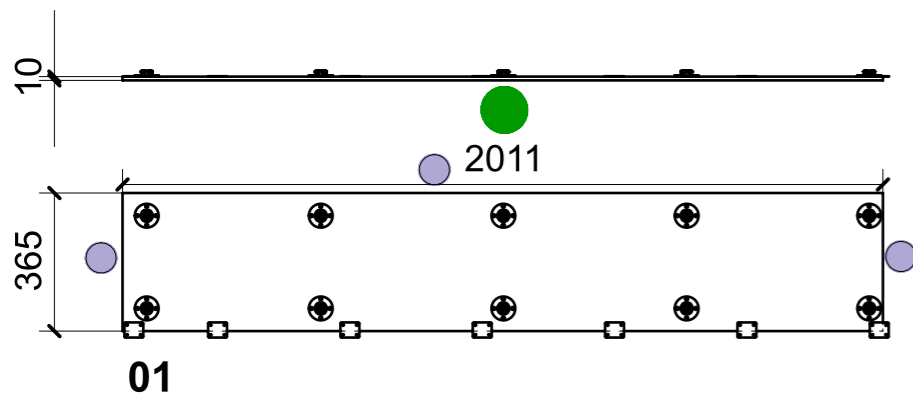

01

ELEMENTI DA MONTARE CON R01_02/03/04 IN MF_AS01
e spedire con unico imballo

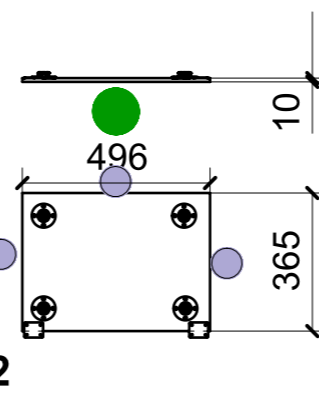
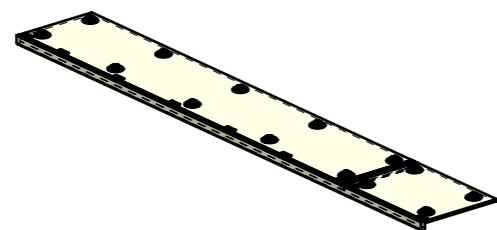

02

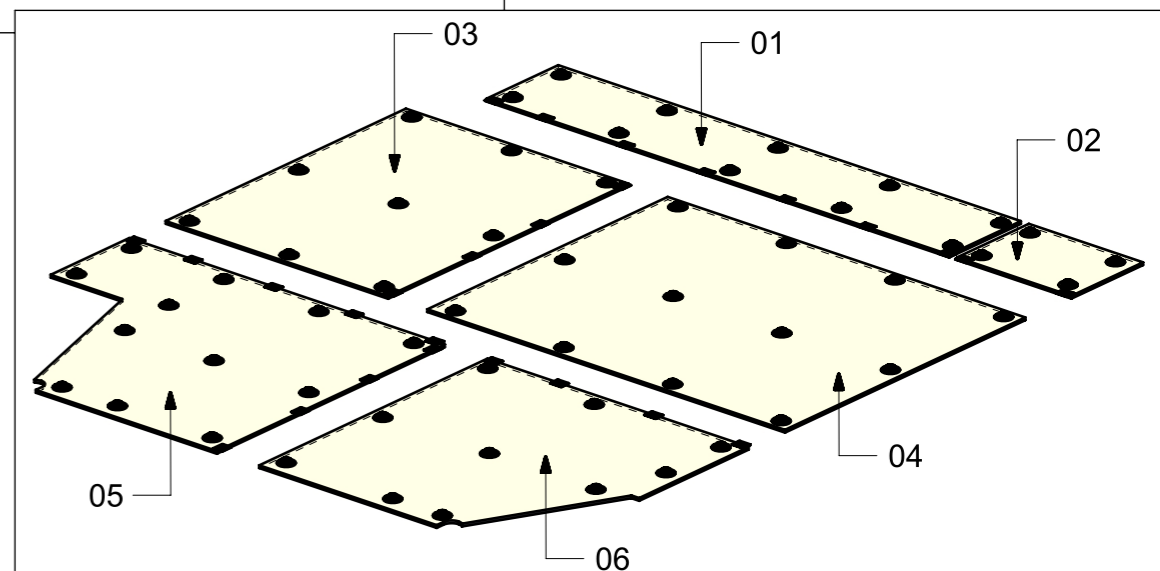

FERRAMENTA	QTY
FITLOCK M_MASCHERPA_3MM_6020202101	57
PIASTRINA SP.1MM 50X40_FBC_ART_264 Z	26

VERNICIATURA LASTRA/LACCATI:

● FILI RASATI

● = VERNICIARE 1 LATO + FILI RASATI O BORDATI

NESSUN SIMBOLO = VERNICIARE 2 LATI + FILI RASATI O BORDATI

LOCALE	CODICE	DESCRIZIONE COMPONENTE	FINITURA	GR.
CABINA ARMATORE	MD299_L01_AU01	ANTE MOBILE MURATA_STD VAR 2 VERDE 100 GLOSS	LACCATO VERDE NCS S 5020 B70G LUCIDO 100 gloss	06

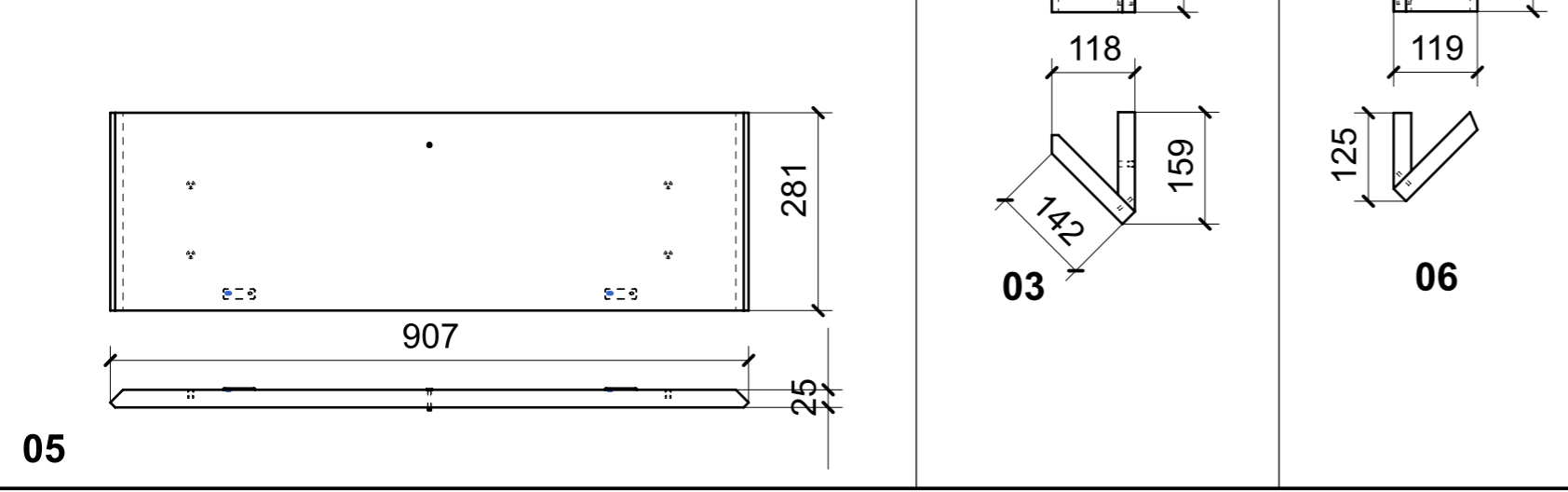
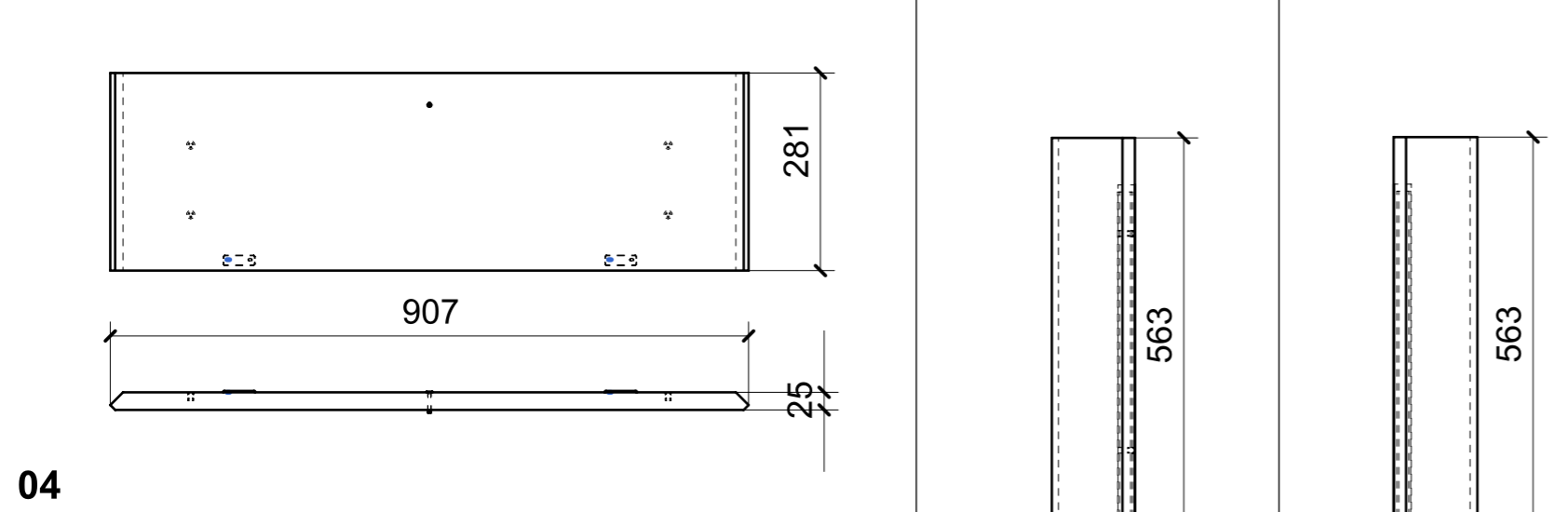
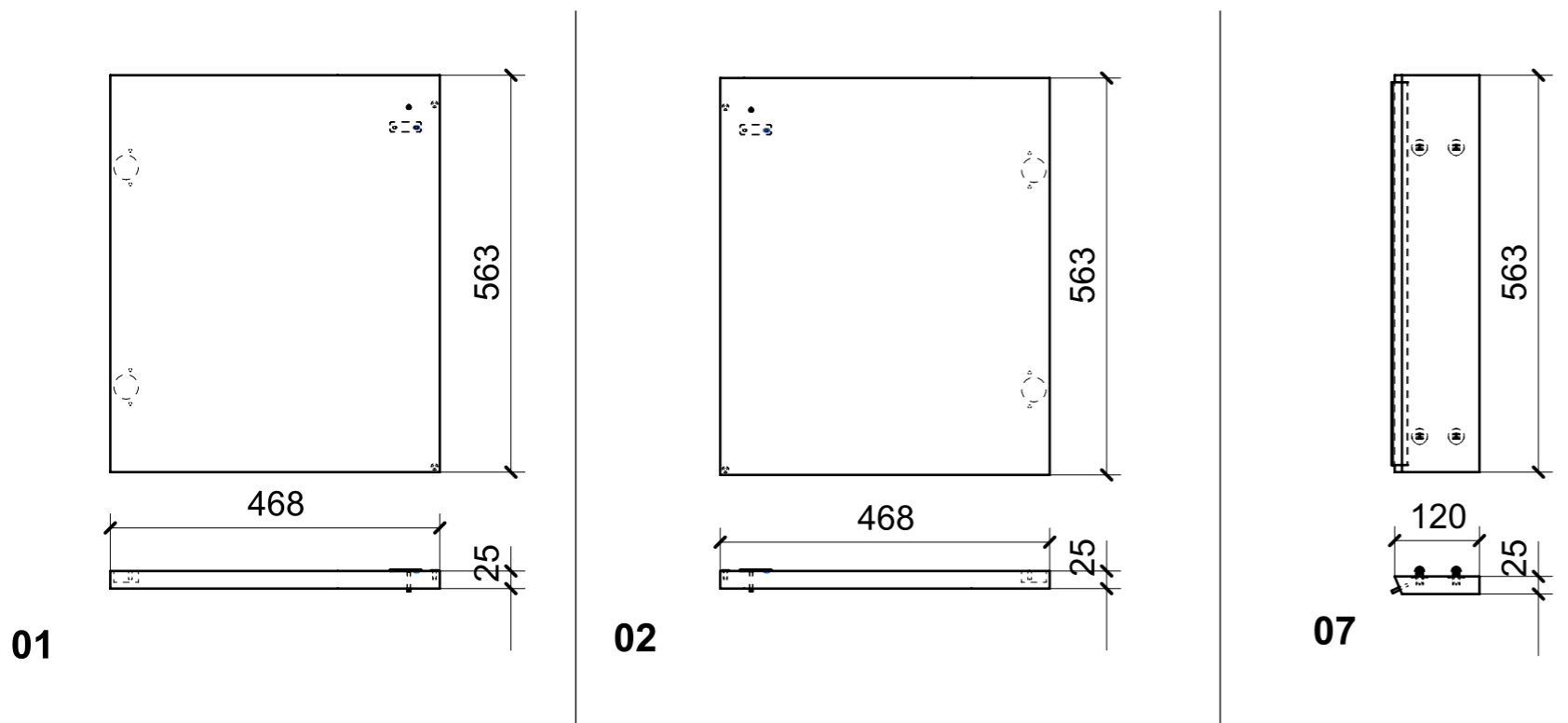

ELEMENTI DA MONTARE CON A10/A11/A12/A22 IN MF_AU01
e spedire con unico imballo

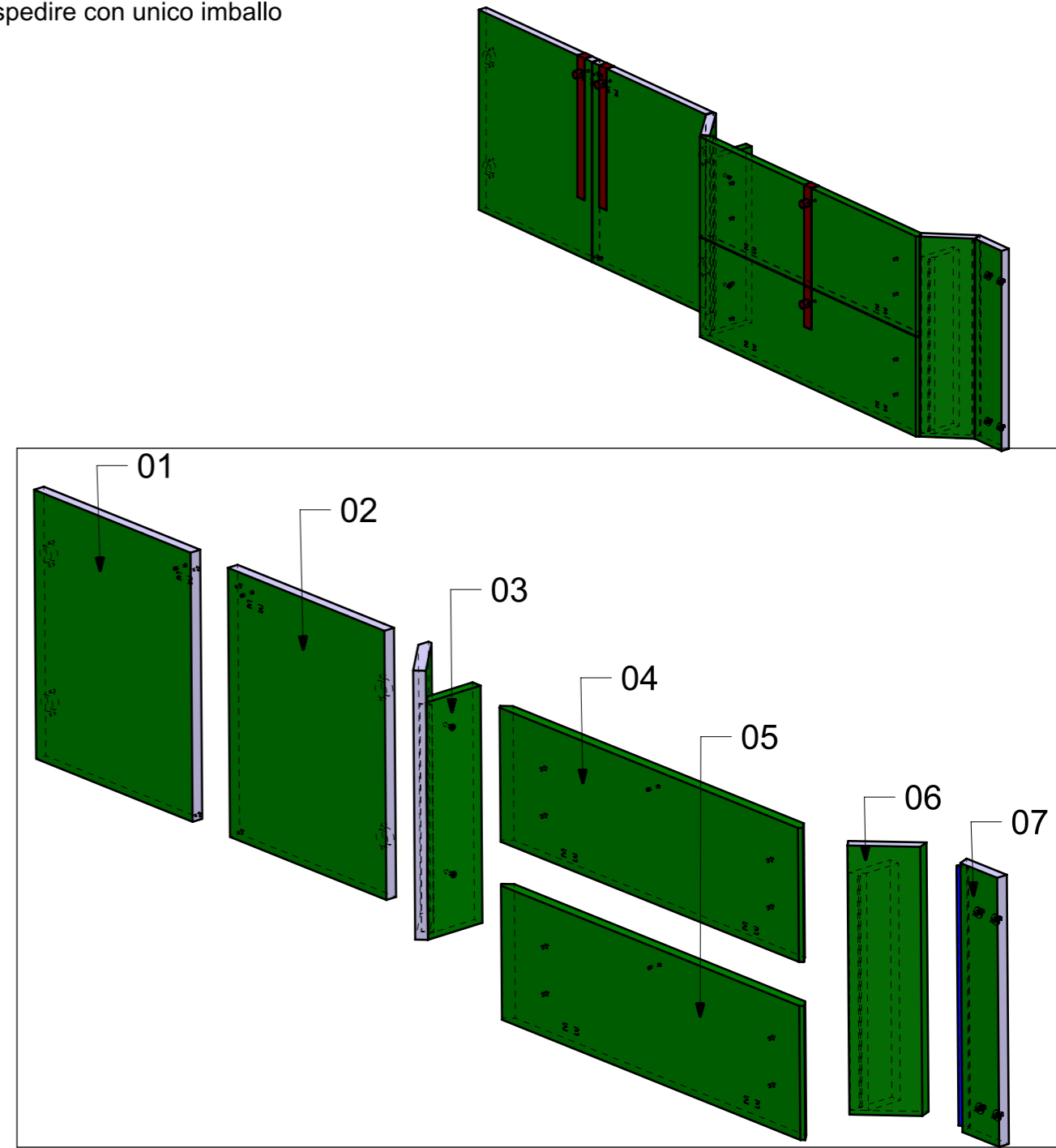

FERRAMENTA	QTY
BUSSOLA 5MA X 10 FORO DIAM.8	8
BUSSOLA 6MA X 10 FORO DIAM.8	2
GOMMINO PARACOLPO ANTA	4
MS INCASSO_ITALVIPLA_972_FMPC_M1B	4
PLACCHETTA COUNTER STEEL_TECHNOPARTNER_MC-JM49	6
VITE 4MA X 30 TESTA SVASATA ESAGONALE NERA	4

VERNICIATURA LASTRA/LACCATI:
● = VERNICIARE 1 LATO + FILI RASATI O BORDATI NESSUN SIMBOLO = VERNICIARE 2 LATI + FILI RASATI O BORDATI

LOCALE	CODICE	DESCRIZIONE COMPONENTE	FINITURA	GR.
CABINA ARMATORE	MD299_L01_AV01	ANTE MOBILE MURATA_STD VAR 1 AZZURRO\GRIGIO 100 GLOSS	LACCATO AZZURRO\GRIGIO NCS S 3005 B 80 G 100 gloss	06

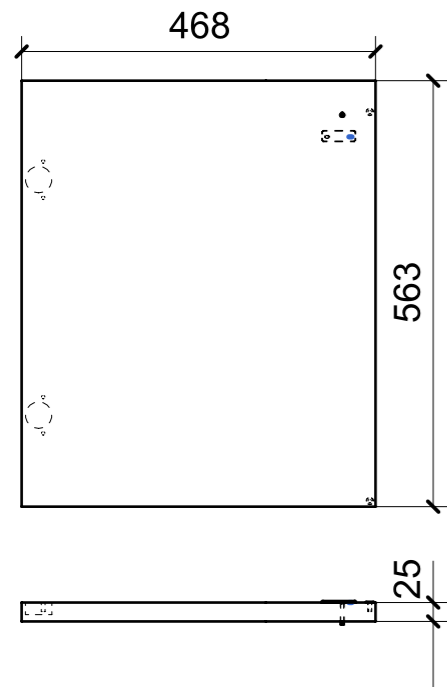

01

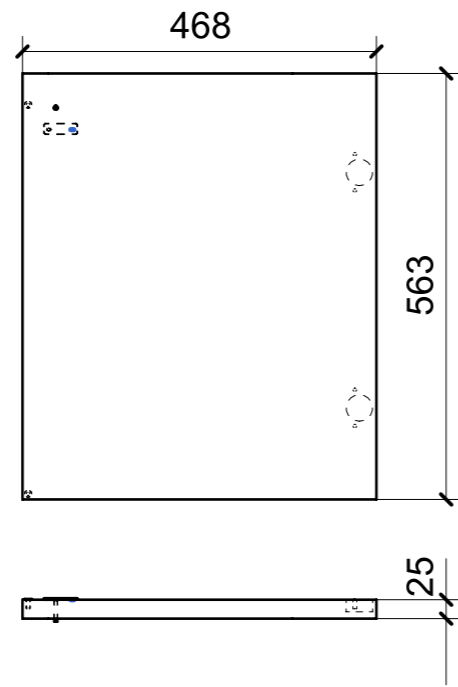

02

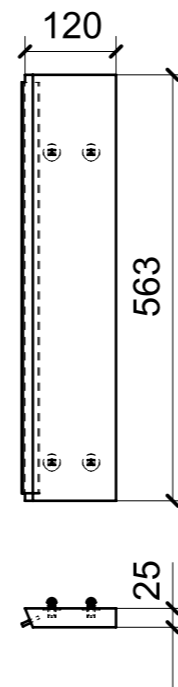

07

ELEMENTI DA MONTARE CON A10/A11/A12/A22 IN MF_AV01
e spedire con unico imballo

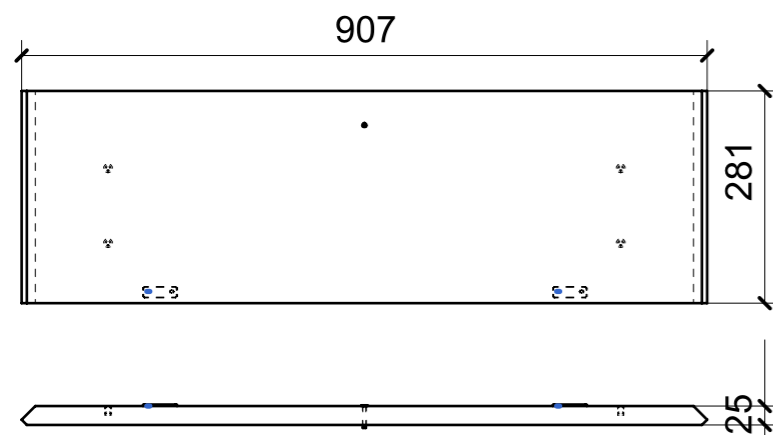
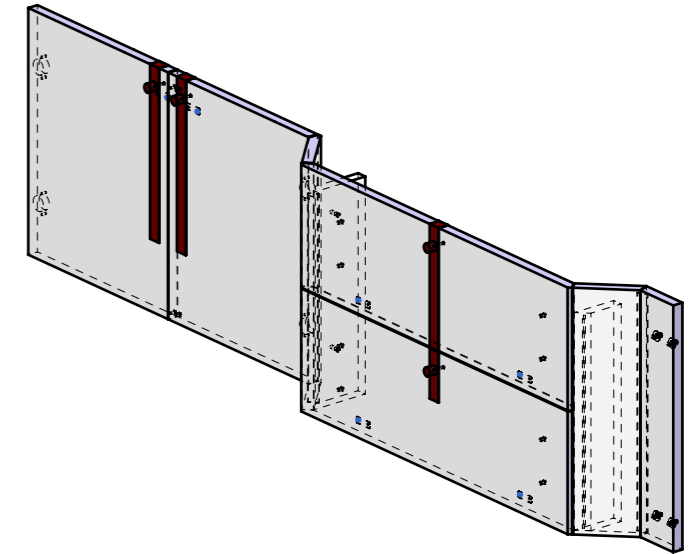

04

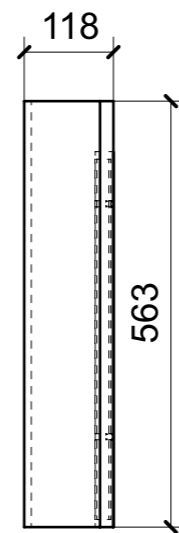

03

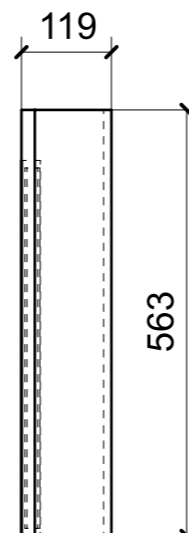

06

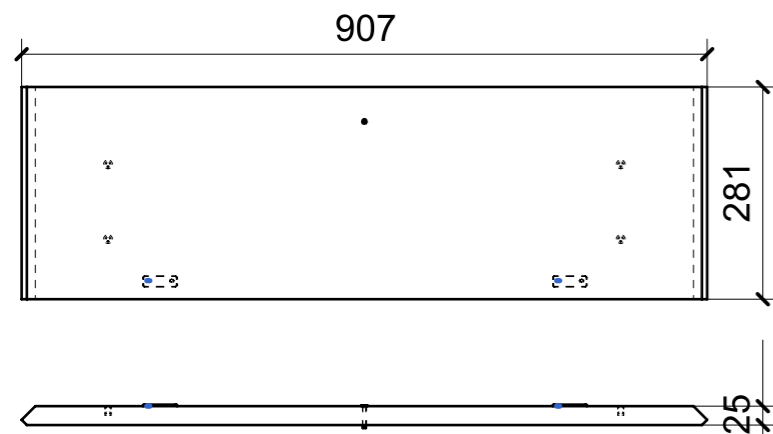

05

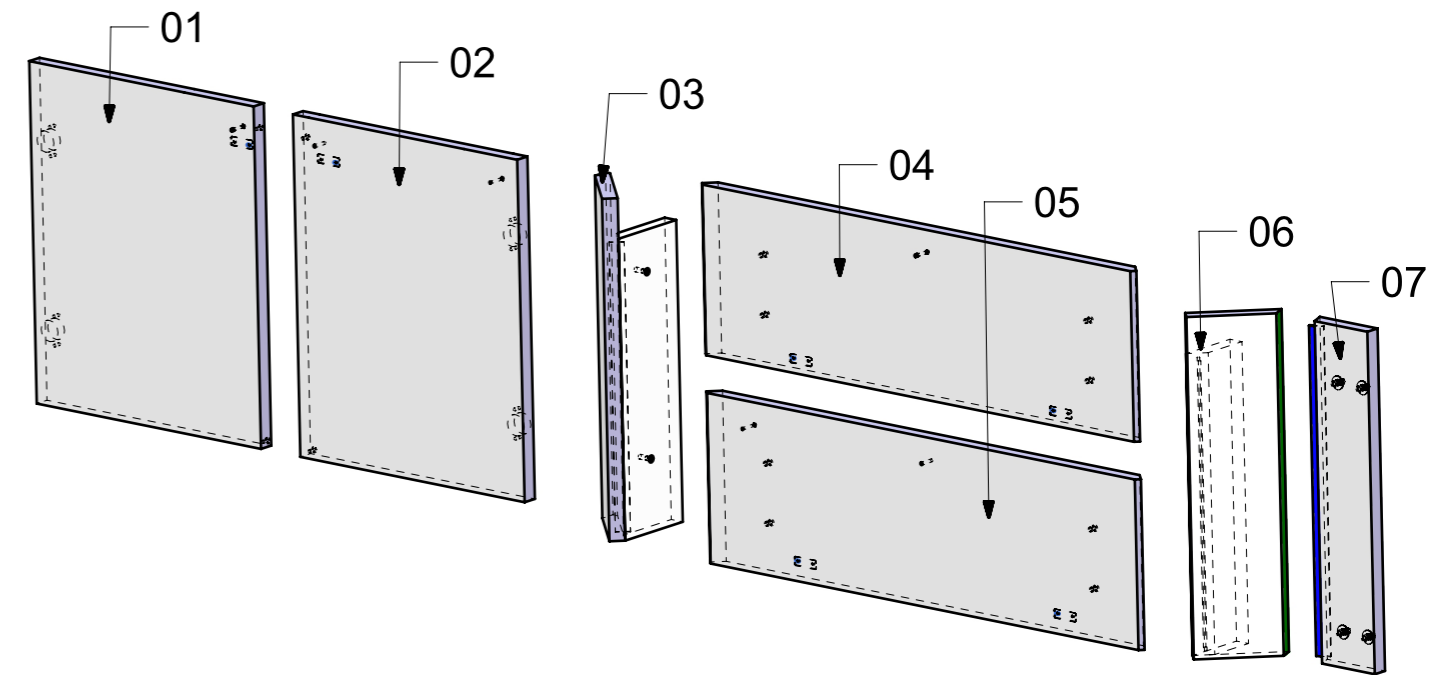
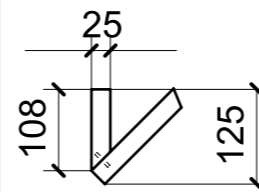
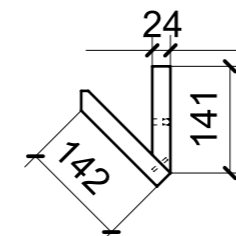

FERRAMENTA	QTY
BUSSOLA 5MA X 10 FORO DIAM.8	8
BUSSOLA 6MA X 10 FORO DIAM.8	2
GOMMINO PARACOLPO ANTA	4
MS INCASSO_ITALVIPLA_972_FMPC_M1B	4
PLACCHETTA COUNTER STEEL_TECHNOPARTNER_MC-JM49	6
VITE 4MA X 30 TESTA SVASATA ESAGONALE NERA	8

VERNICIATURA LASTRA/LACCATI:

● = VERNICIARE 1 LATO + FILI RASATI O BORDATI

NESSUN SIMBOLO = VERNICIARE 2 LATI + FILI RASATI O BORDATI