

LOCALE	CODICE	DESCRIZIONE COMPONENTE	FINITURA	Q.TA
CABINA ARMATORE	MD299_MF_AA01	ARMADIO SX PRUA		1

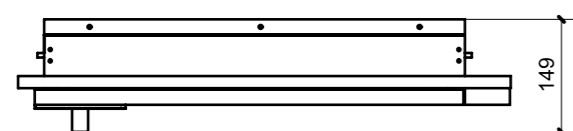
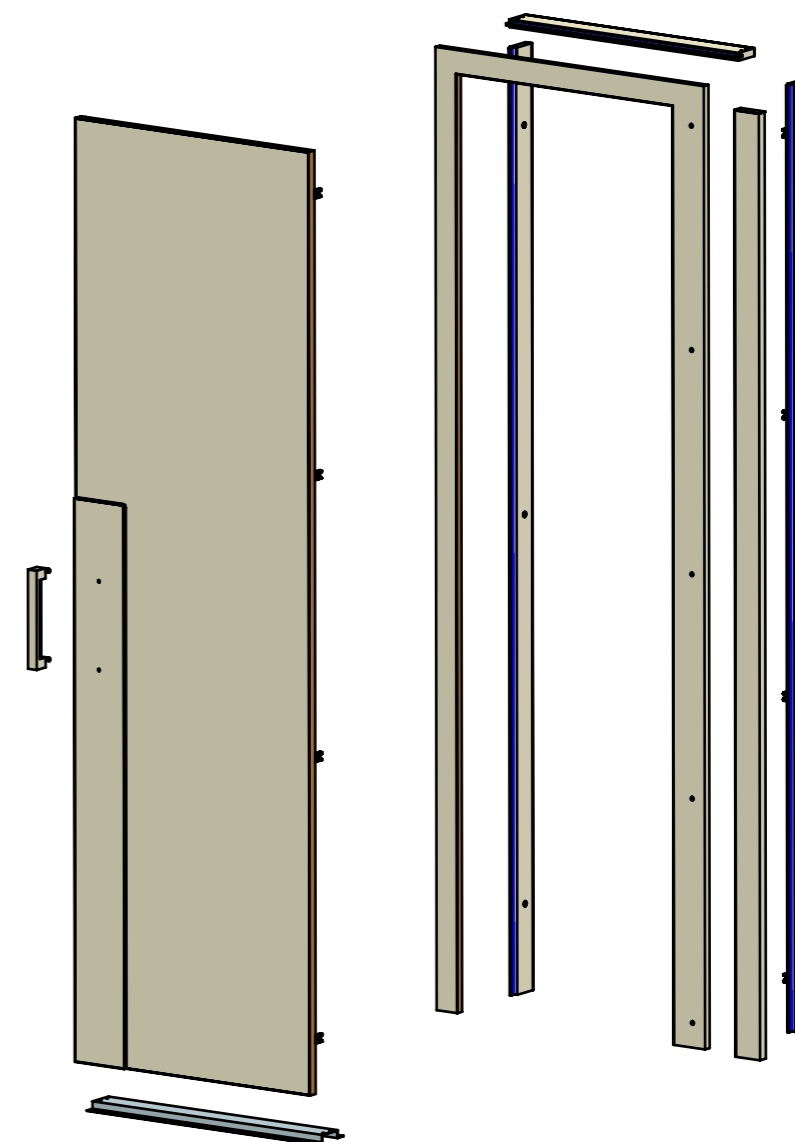
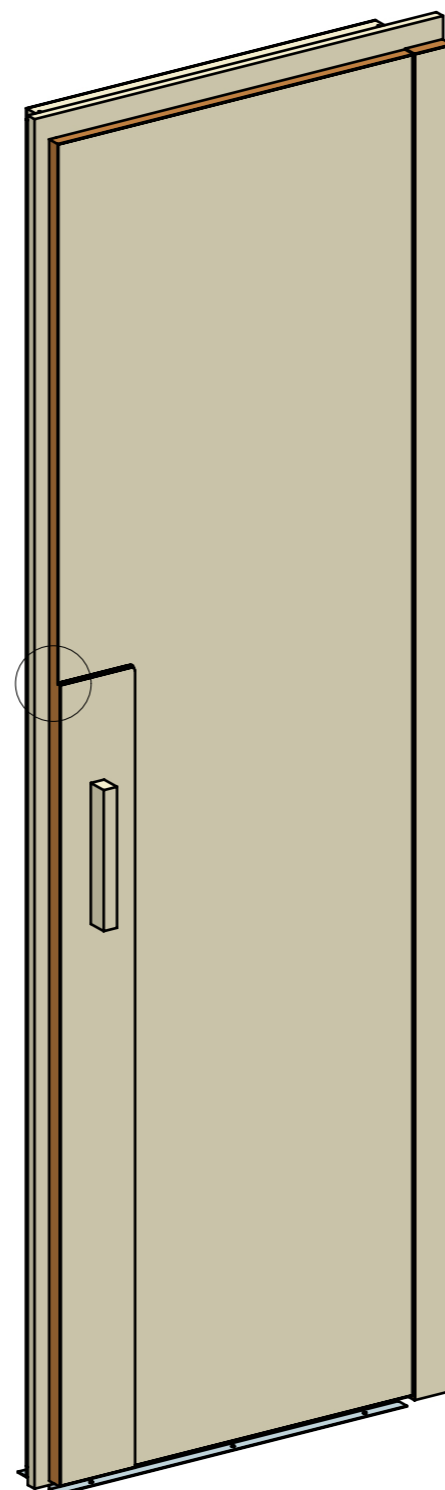
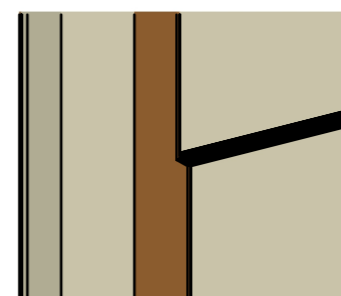
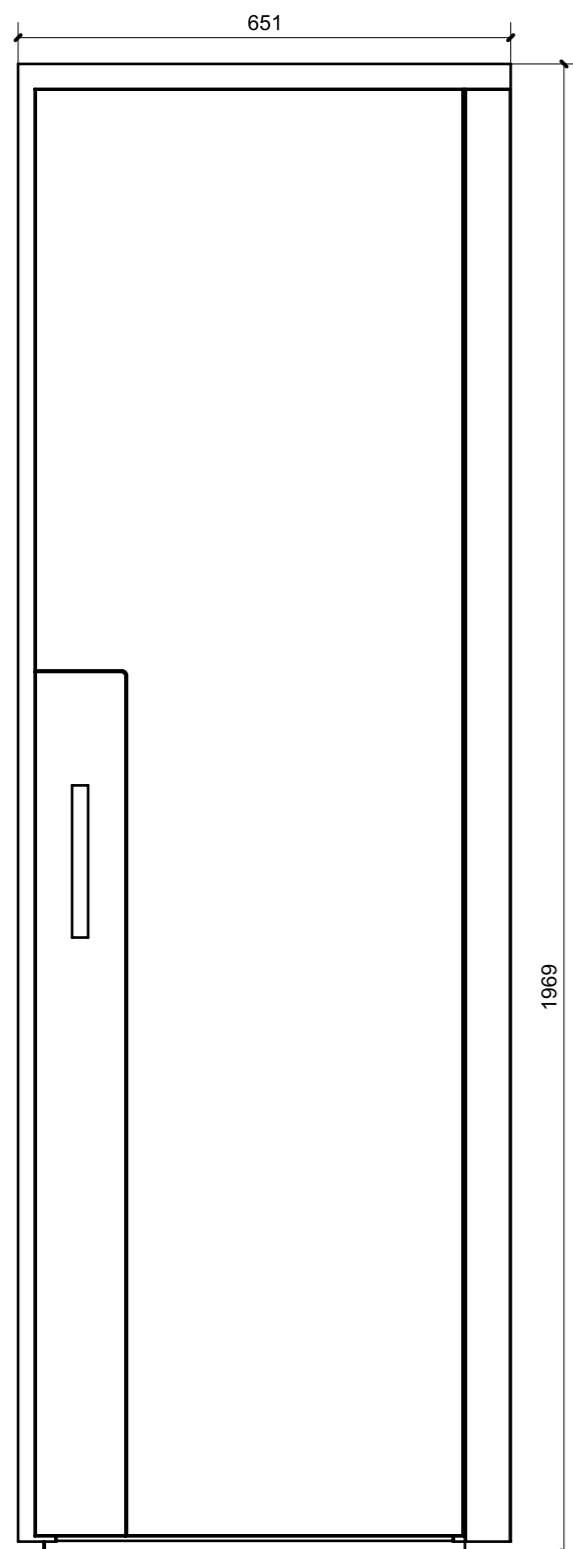

FERRAMENTA	QTY
BASE_6_HAFELE_329_84_026	4
BUSSOLA 4MA X 10 FORO DIAM.6	2
BUSSOLA 5MA ANKOR BORGHI X CERNIERA PIANA	16
CALAMITA SEALED MAGNETIC_TECNOPARTNER_MC-JM50-BL	2
CERNIERA 94° PIANA AMMORTIZZATA_HAFELE_329_49_310	4
GOMMINO PARACOLPO ANTA	2
PLACCHETTA COUNTER STEEL_TECNOPARTNER_MC-JM49	2
VITE 4MA X 30 TESTA SVASATA ESAGONALE NERA	2
VITE 4MAX8 ANKOR BORGHI X CERNIERA PIANA	16
VITE 6MA X 25 TESTA SVASATA	6

VERNICIATURA LASTRA/LACCATI:

● = VERNICIARE 1 LATO + FILI RASATI O BORDATI

NESSUN SIMBOLO = VERNICIARE 2 LATI + FILI RASATI O BORDATI

LOCALE	CODICE	DESCRIZIONE COMPONENTE	FINITURA	Q.TA
CABINA ARMATORE	MD299_MF_AL	TAVOLINO A RIBALTA MURATA DX_OPT		1

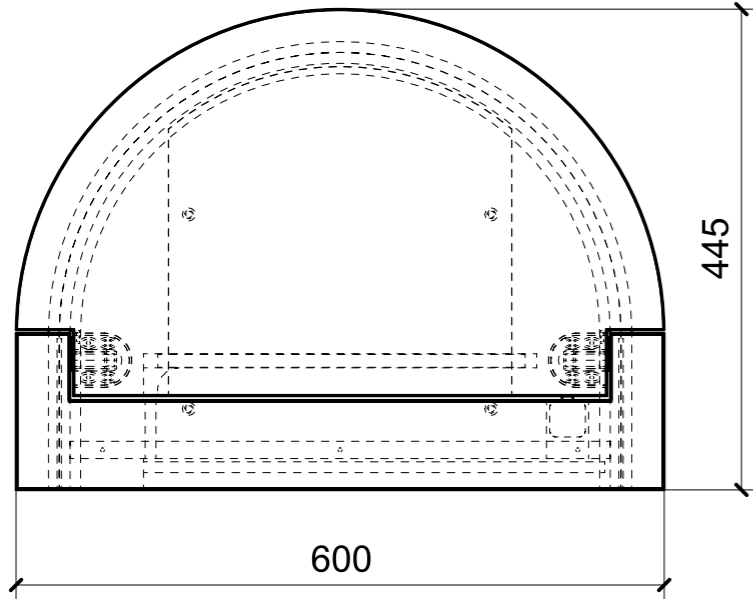
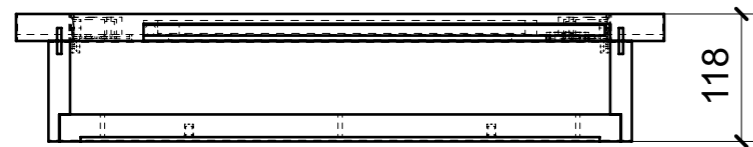

MF\_AL01

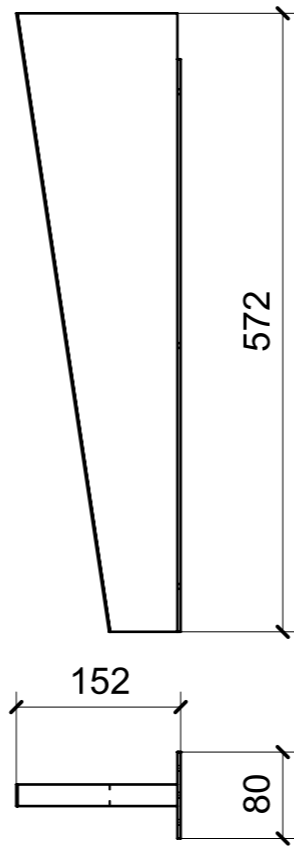

MF\_AL02

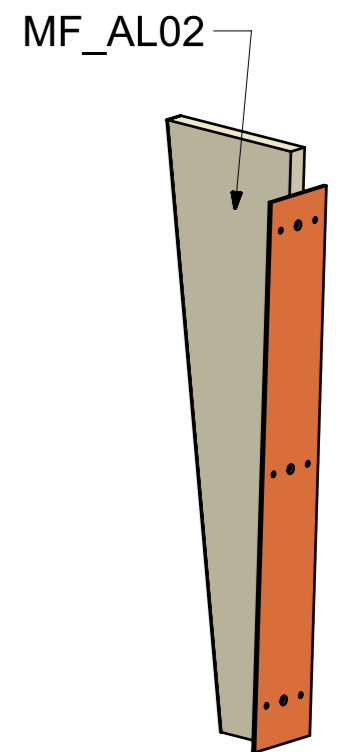
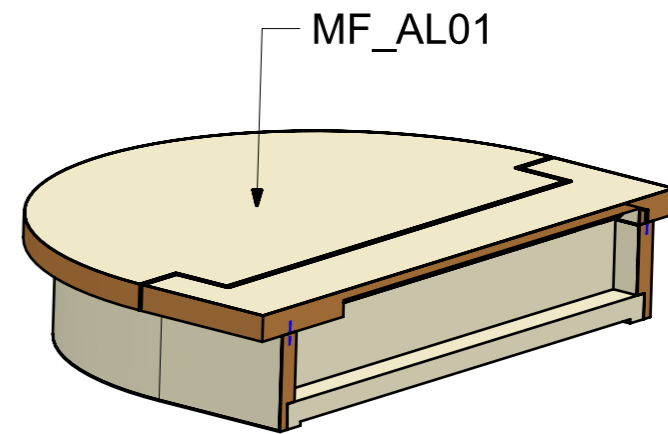

LOCALE	CODICE	DESCRIZIONE COMPONENTE	FINITURA	Q.TA
CABINA ARMATORE	MD299_MF_AO01	STRUTTURA TESTALETTO		1

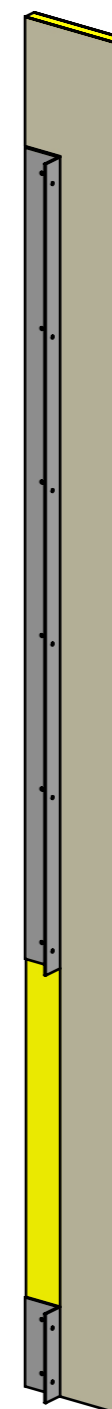
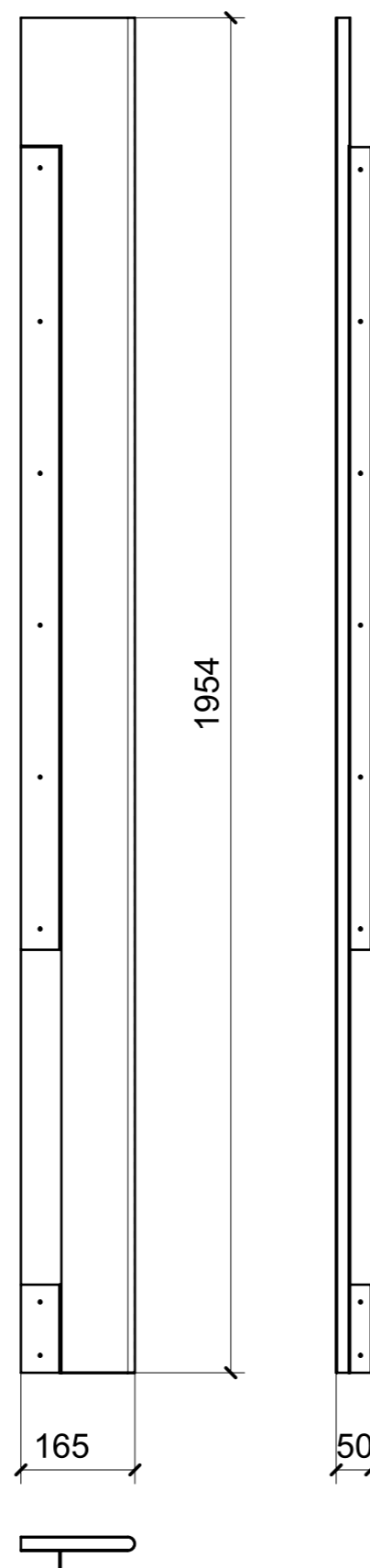

LOCALE	CODICE	DESCRIZIONE COMPONENTE	FINITURA	Q.TA
CABINA ARMATORE	MD299_MF_AS01	CIELINO		1

MD299\_MF\_AS02

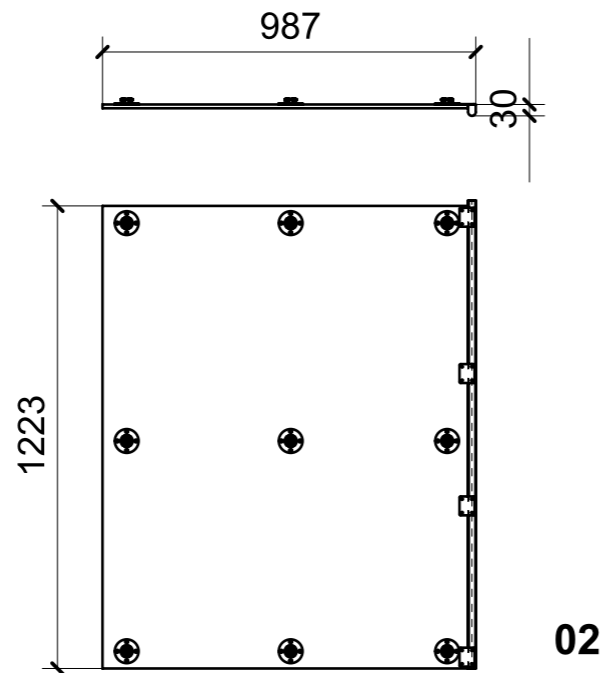
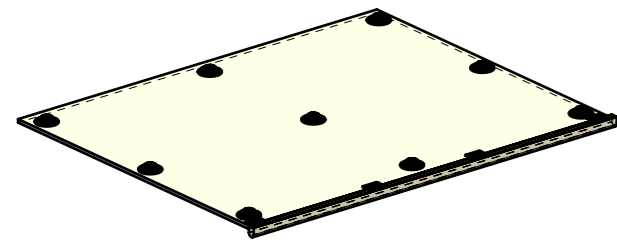

02

MD299\_MF\_AS01

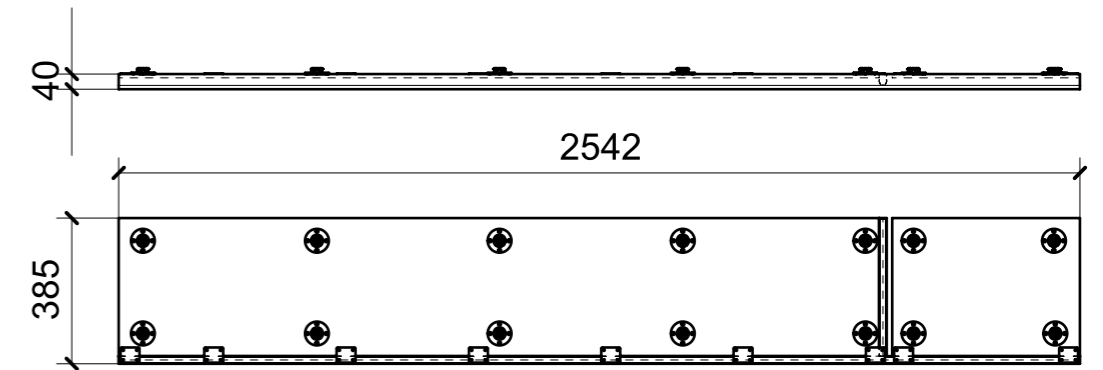
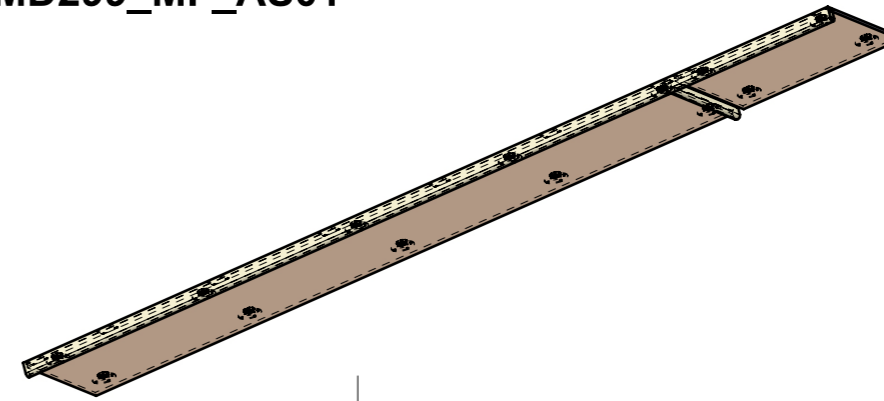

01

MD299\_MF\_AS03

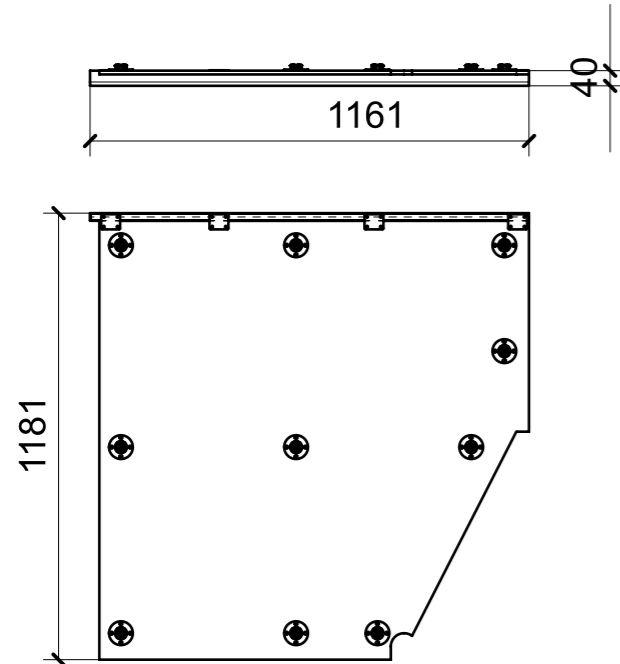
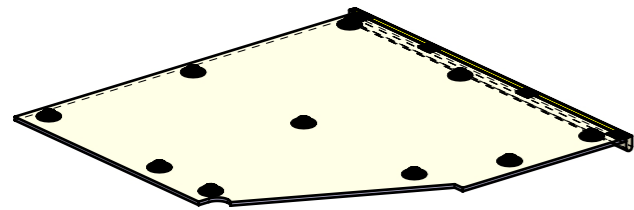

03

MD299\_MF\_AS04

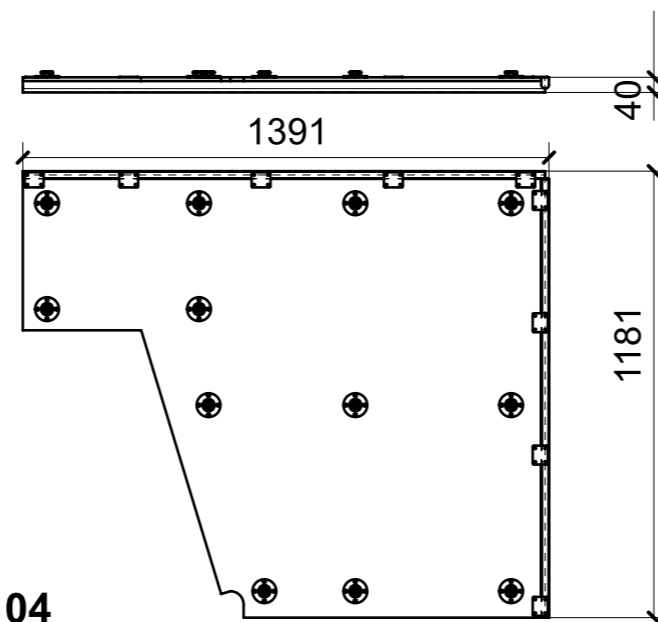
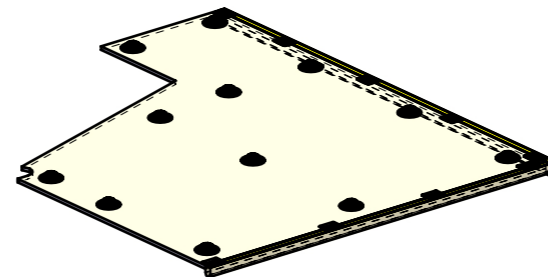

04

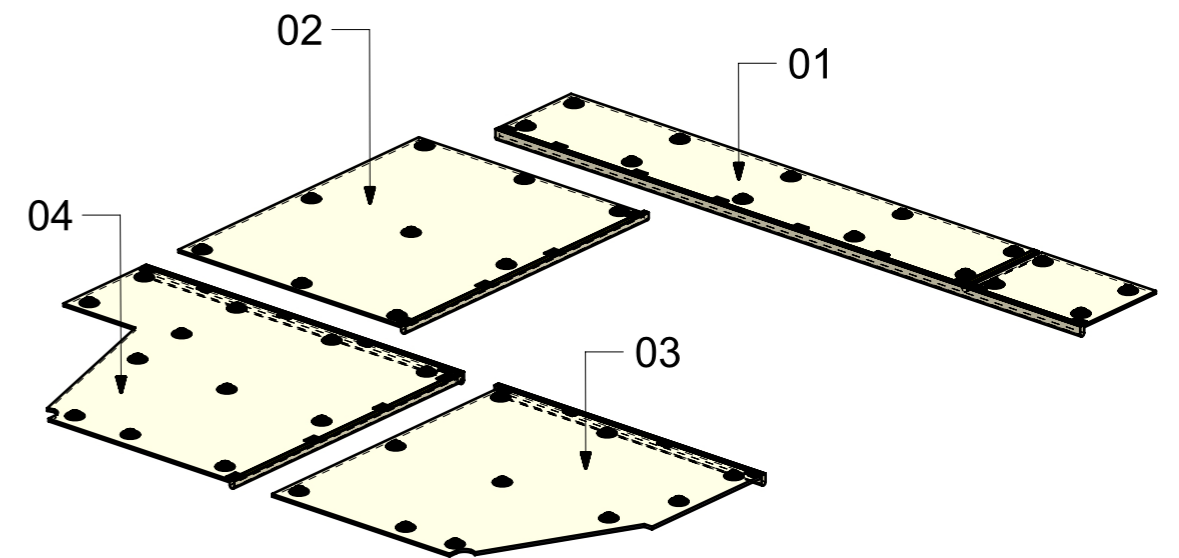

LOCALE	CODICE	DESCRIZIONE COMPONENTE	FINITURA	GR.
CABINA ARMATORE	MD299_MF_AU01	ANTE MOBILE MURATA_STD VAR 2 VERDE 100 GLOSS		06

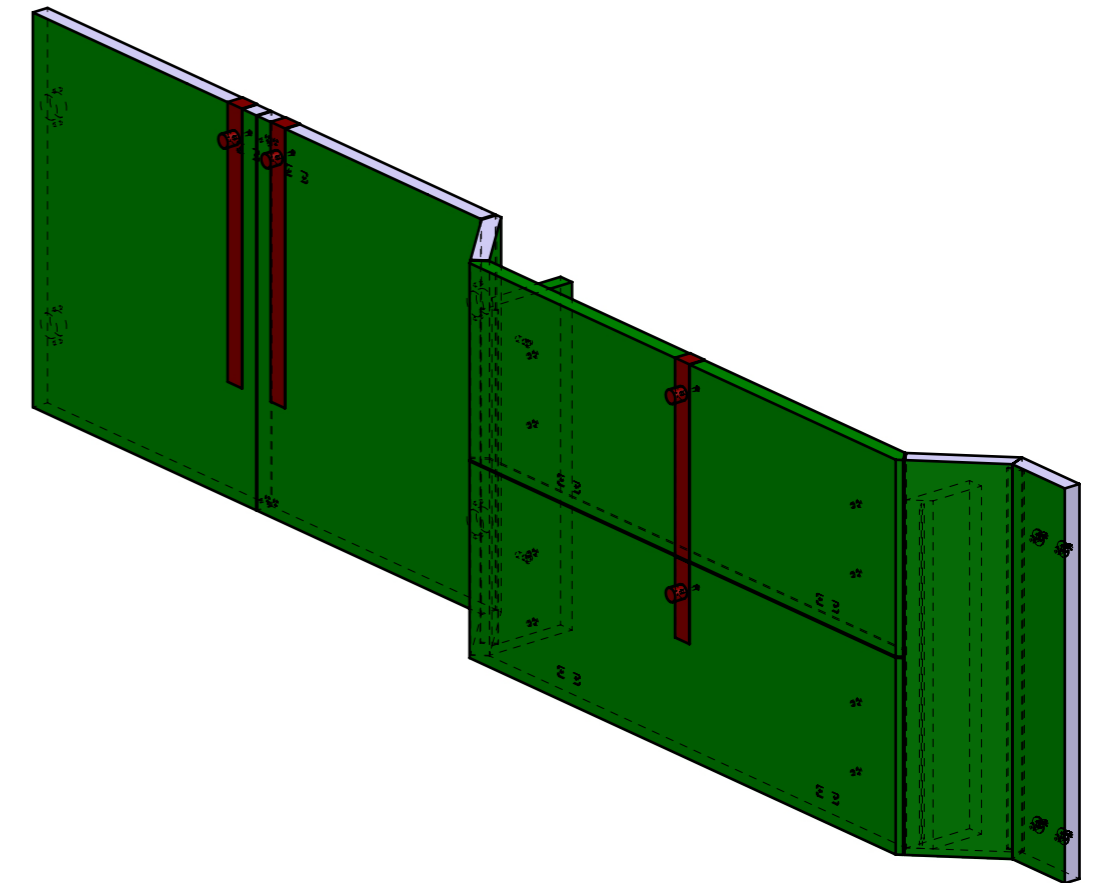
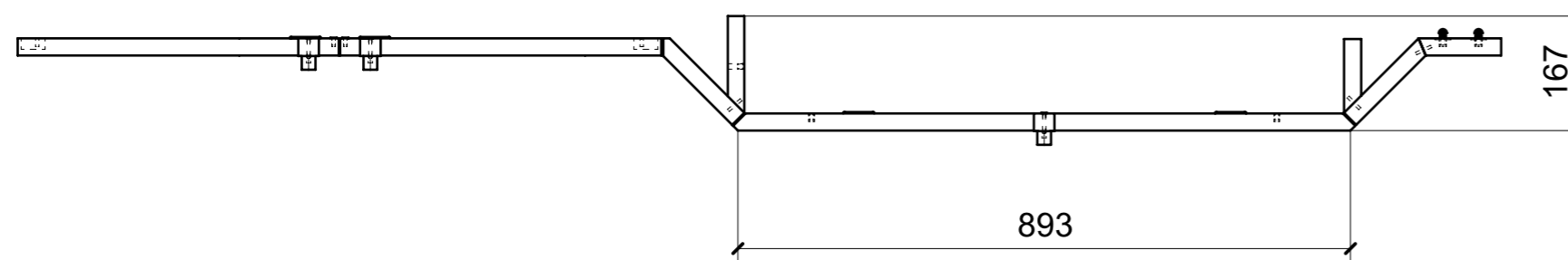
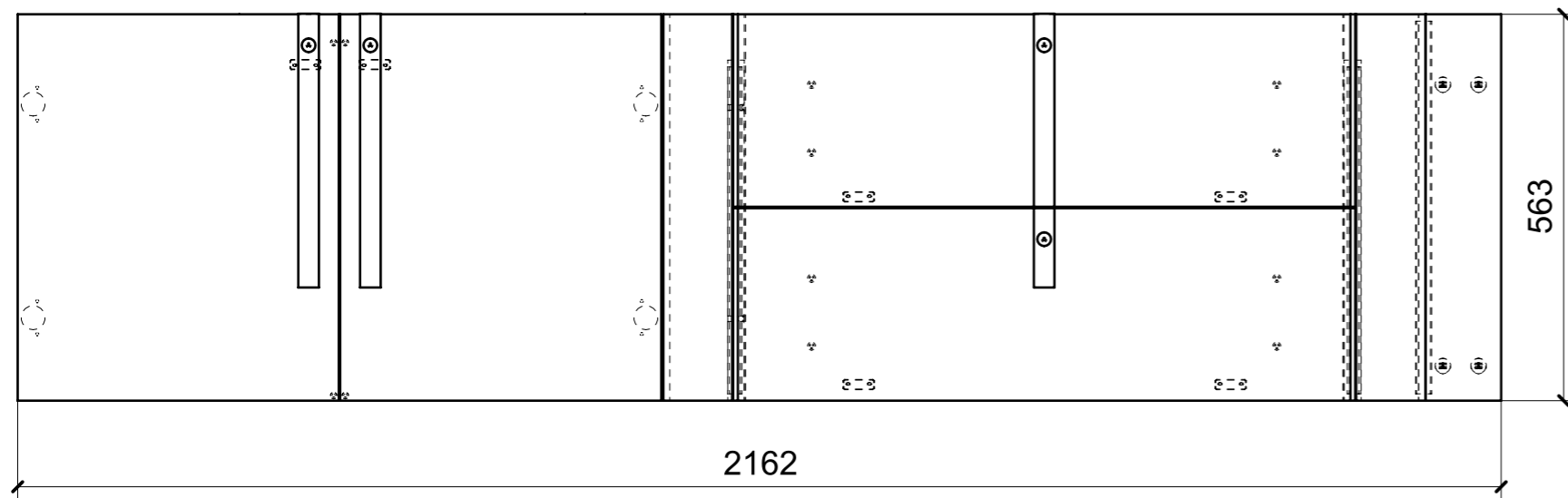

FERRAMENTA	QTY
BUSSOLA 5MA X 10 FORO DIAM.8	8
BUSSOLA 6MA X 10 FORO DIAM.8	2
GOMMINO PARACOLPO ANTA	4
MS INCASSO_ITALVIPLA_972_FMPC_M1B	4
PLACCHETTA COUNTER STEEL_TECHNOPARTNER_MC-JM49	6
VITE 4MA X 30 TESTA SVASATA ESAGONALE NERA	4

LOCALE	CODICE	DESCRIZIONE COMPONENTE	FINITURA	GR.
CABINA ARMATORE	MD299_MF01_AV01	ANTE MOBILE MURATA_STD VAR 1 AZZURRO\GRIGIO 100 GLOSS		06

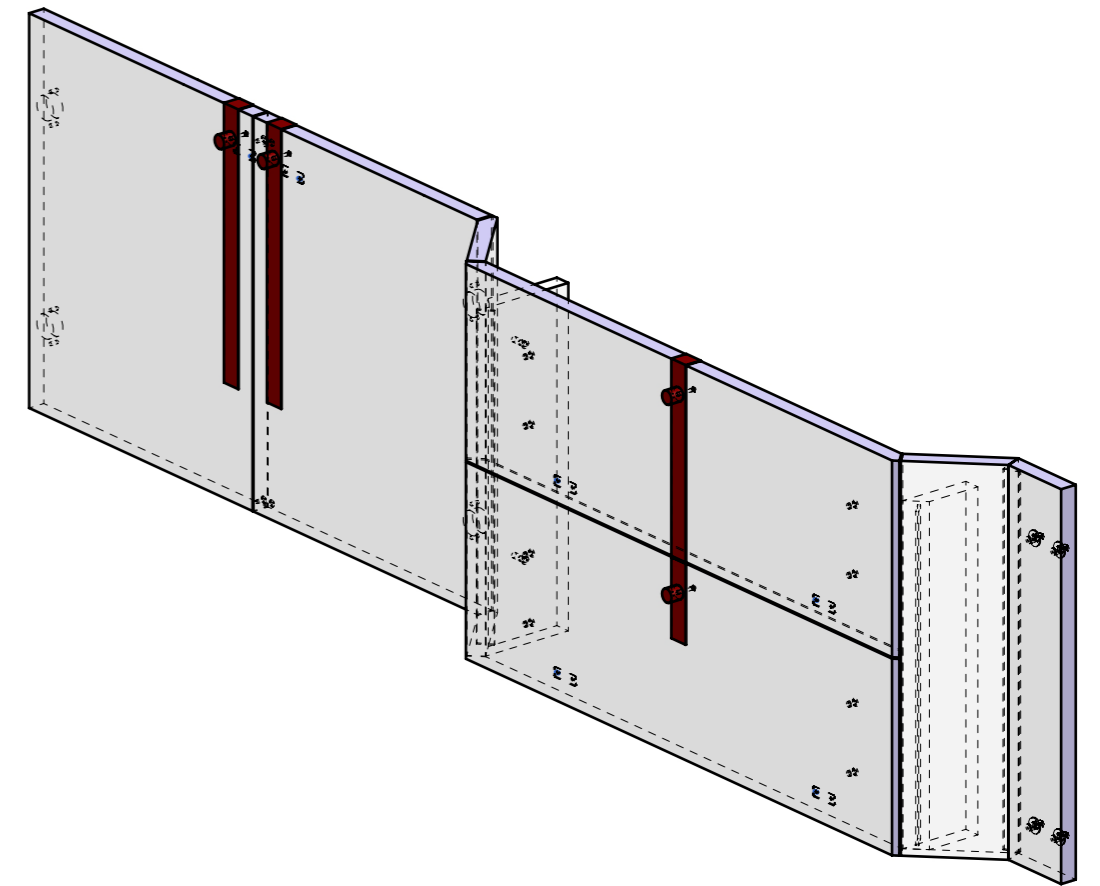
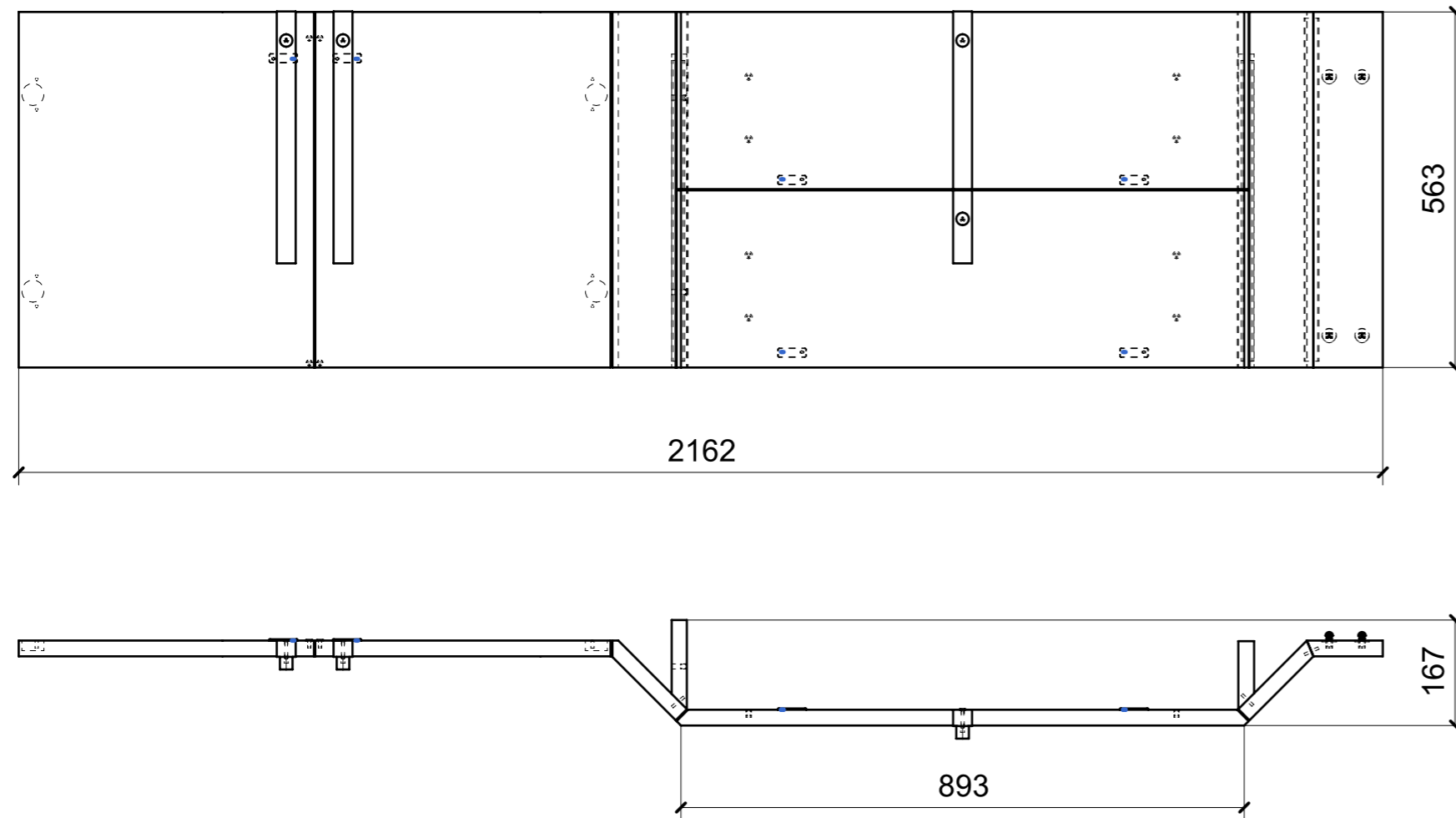

FERRAMENTA	QTY
BUSSOLA 5MA X 10 FORO DIAM.8	8
BUSSOLA 6MA X 10 FORO DIAM.8	2
GOMMINO PARACOLPO ANTA	4
MS INCASSO_ITALVIPLA_972_FMPC_M1B	4
PLACCHETTA COUNTER STEEL_TECHNOPARTNER_MC-JM49	6
VITE 4MA X 30 TESTA SVASATA ESAGONALE NERA	8