

AZ68F

DA MAT. 203 REV. 29-04-2024

LOCALE	CODICE	DESCRIZIONE COMPONENTE	FINITURA	Q.TA	OPERATORE
SALONE	AZ68F-L01_SA01	COLONNA SX	LACCATO BRONZO	1	Damiano

64-65
MODIFICATO GEOMETRIA E
DIVENTATO LACCATO
(PRIMA ERA ACCIAIO)

FINIRE BENE
FILO SOTTILE

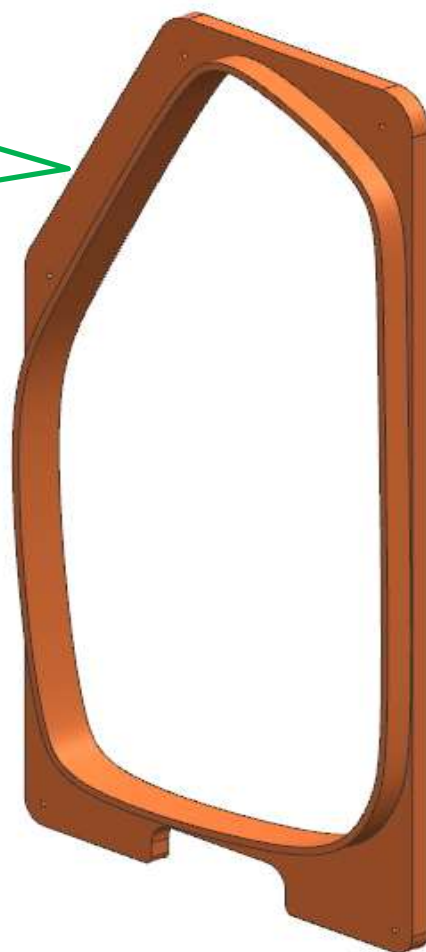

-INTERNO
-PERIMETRO-FACCIA INTERNA

ELEMENTO DA
MONTARE con:
SA01
R01_SA01
R02_SA01
I01_SA01
P01_SA01
e spedire con un unico
imballo

R01_SA01

R02_SA01

SA01

L02_SA01

I01_SA01

P01_SA01

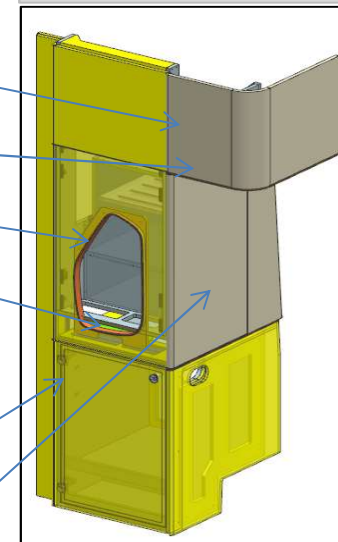

consonni&c

AZ68F

DA MAT. 203 REV. 29-04-2024

LOCALE	CODICE	DESCRIZIONE COMPONENTE	FINITURA	Q.TA	OPERATORE
SALONE	AZ66F-L02_SA01	COLONNA SX	LACCATO HARBOR	1	Damiano

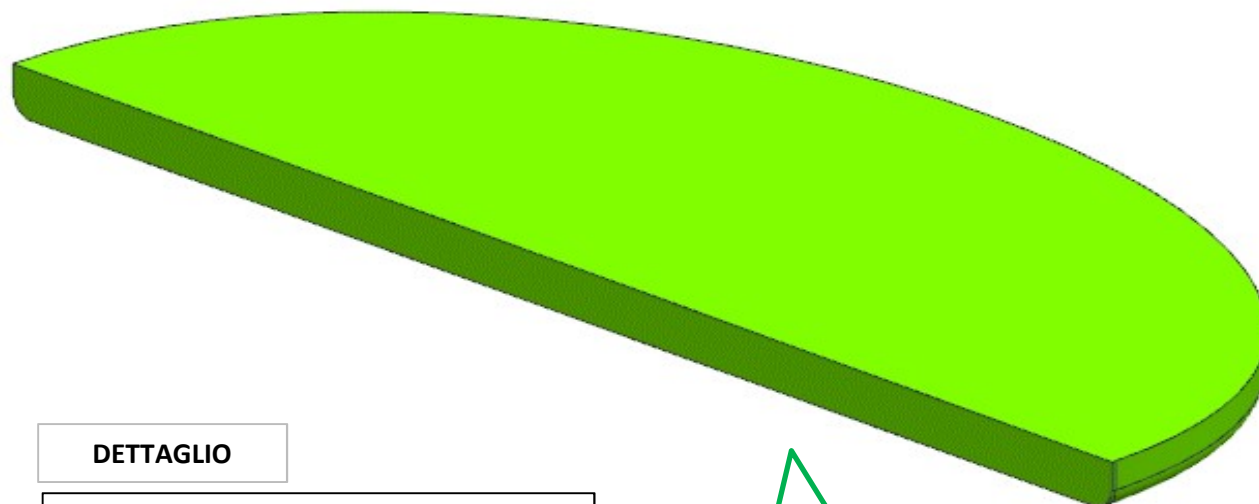

DETTAGLIO

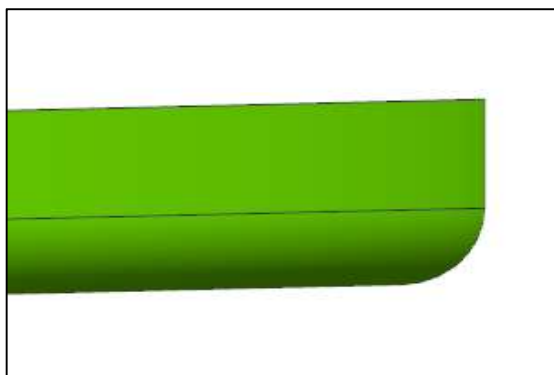

PRIMA ERA
VASSOIETTO IN
LACCATO BRONZO

ELEMENTO DA
MONTARE con:
SA01
R01_SA01
R02_SA01
I01_SA01
P01_SA01
e spedire con un unico
imballo

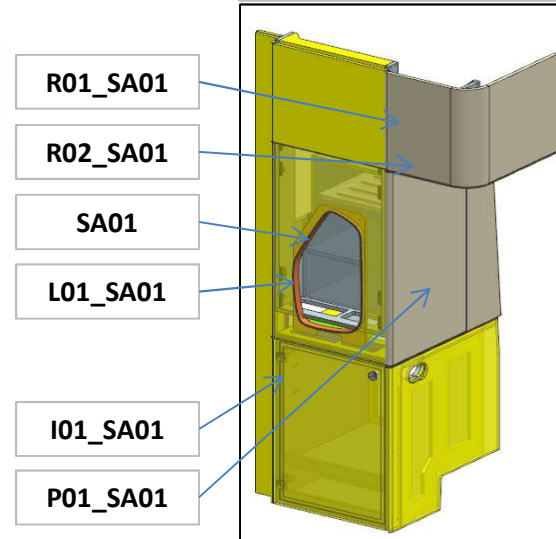

AZ68F

DA MAT. 203 REV. 29-04-2024

LOCALE	CODICE	DESCRIZIONE COMPONENTE	FINITURA	Q.TA	OPERATORE
SALONE	AZ68F-L01_SB01	MURATA BASSA SX POPPA	LACCATO NERO OPACO	4	Damiano

* faccia dove viene applicata la finitura
 ↓ filo dove viene applicata la finitura

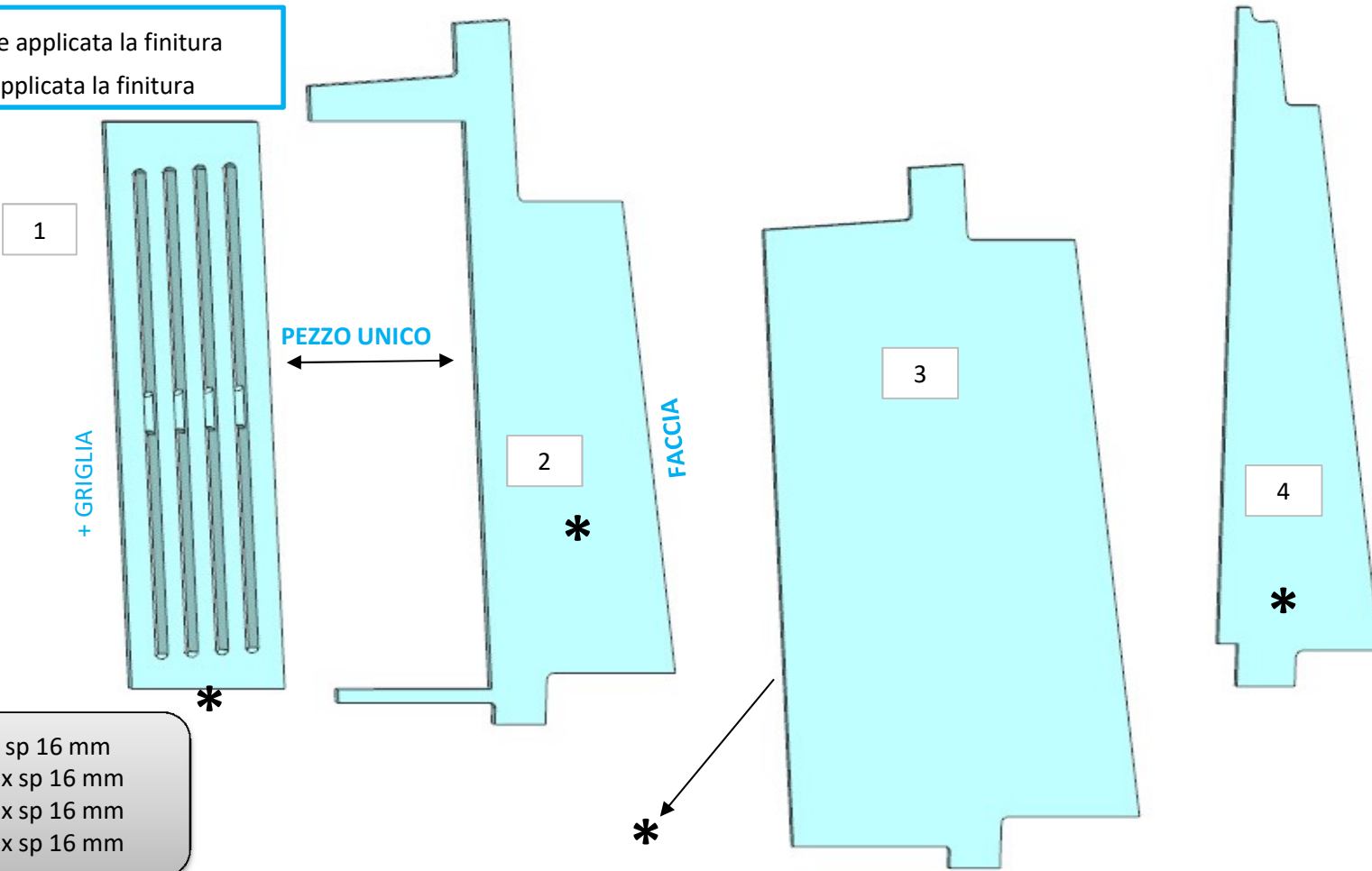

- 1 - L 215 x H 855 x sp 16 mm
- 2 - L 260 x H 1058 x sp 16 mm
- 3 - L 487 x H 1058 x sp 16 mm
- 4 - L 228 x H 1022 x sp 16 mm

AZ68F

DA MAT. 203 REV. 29-04-2024

LOCALE	CODICE	DESCRIZIONE COMPONENTE	FINITURA	Q.TA	OPERATORE
SALONE	AZ68F-L01_SE01	MURATA BASSA SX PRUA	LACCATO NERO OPACO	2	Damiano

1 - L 1005 x H 200 x sp 10
2 - L 749 x H 167 x sp 10

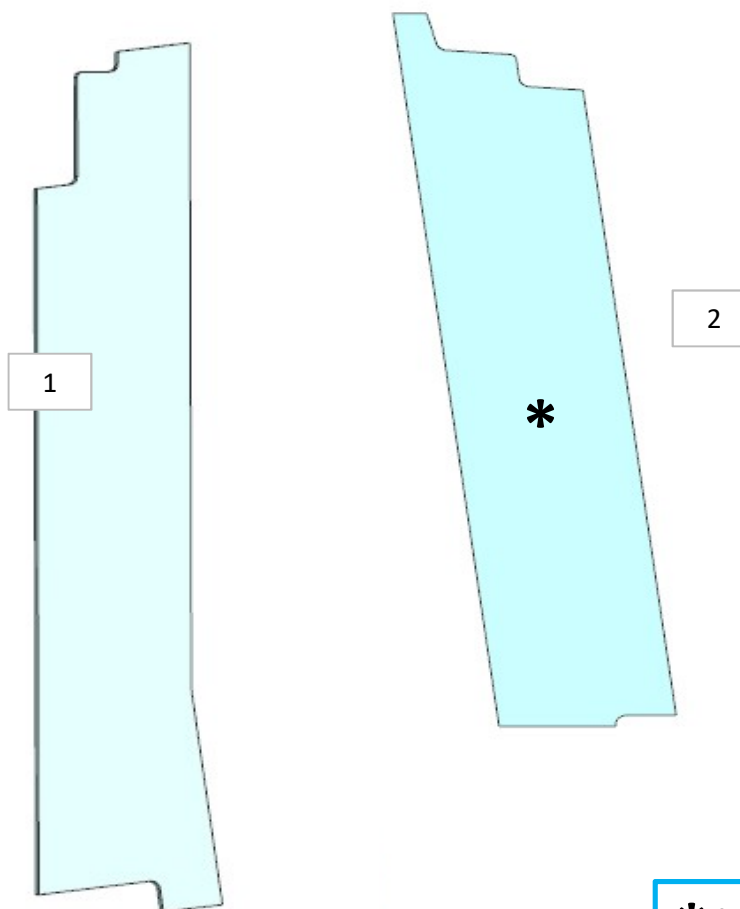

* faccia dove viene applicata la finitura

↓ filo dove

consonni&c

AZ68F

DA MAT. 265 REV. 29-04-2024

LOCALE	CODICE	DESCRIZIONE COMPONENTE	FINITURA	Q.TA	OPERATORE
SALONE	AZ68F-L01_SF01	MANTOVANA SX PRUA	LACCATO BIANCO ARTICO	2	Damiano

1 - L 2538.5 x H 180.5 x 42 mm
2 - L 2537 x H 80 x 36 mm

da mat.207
MODIFICATA SEZIONE PARTE
TONDA

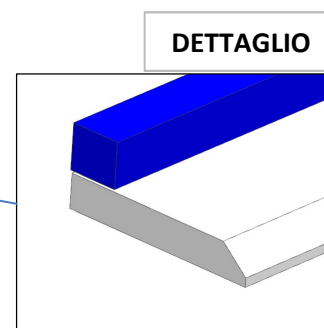
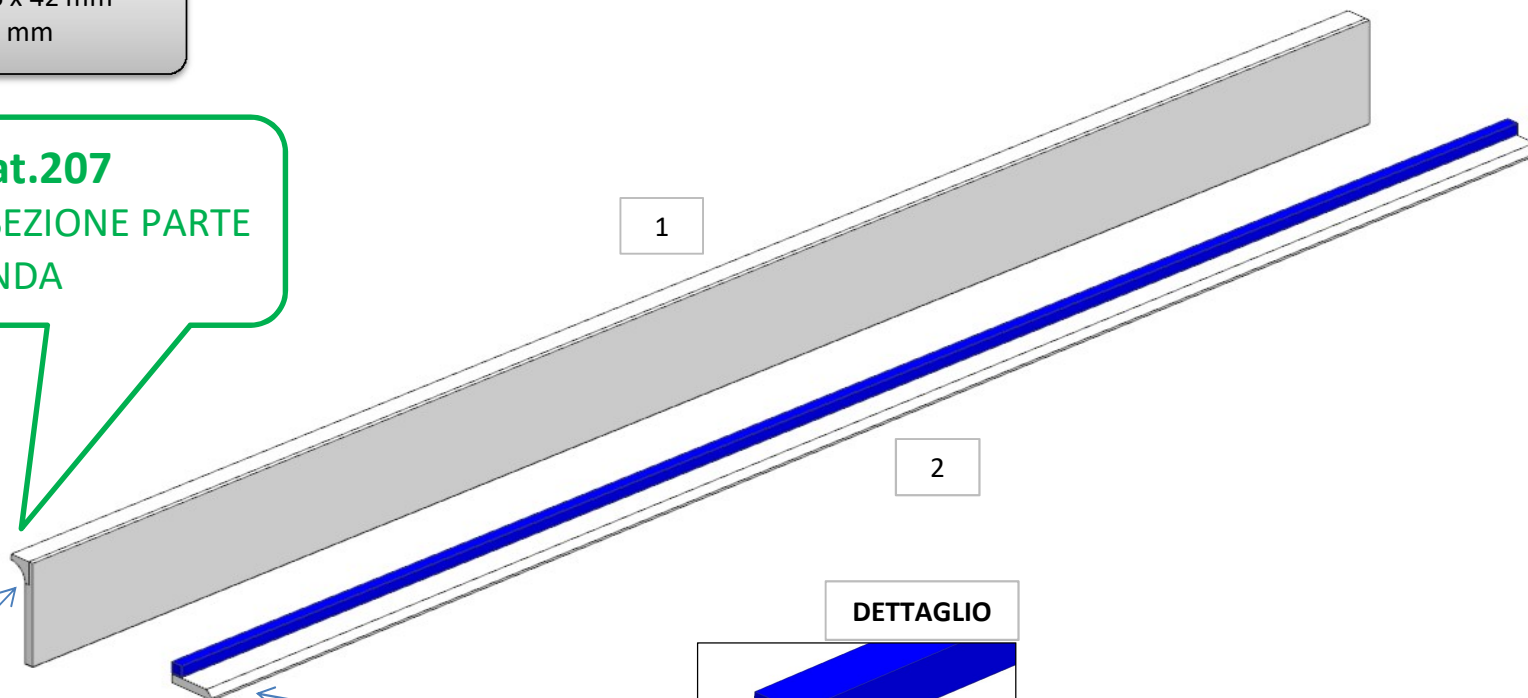
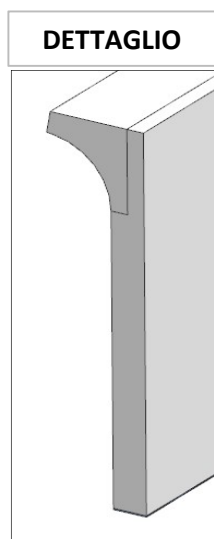

AZ68F

DA MAT. 216 REV. 29-04-2024

LOCALE	CODICE	DESCRIZIONE COMPONENTE	FINITURA	Q.TA	OPERATORE
SALONE	AZ68F-L01_SG01	CASSAPANCA SX	LACCATO BIANCO ARTICO	2	Damiano

1 - L 594.5 x sp 16 mm
2 - svilup. 1516.5 x sp 16 mm

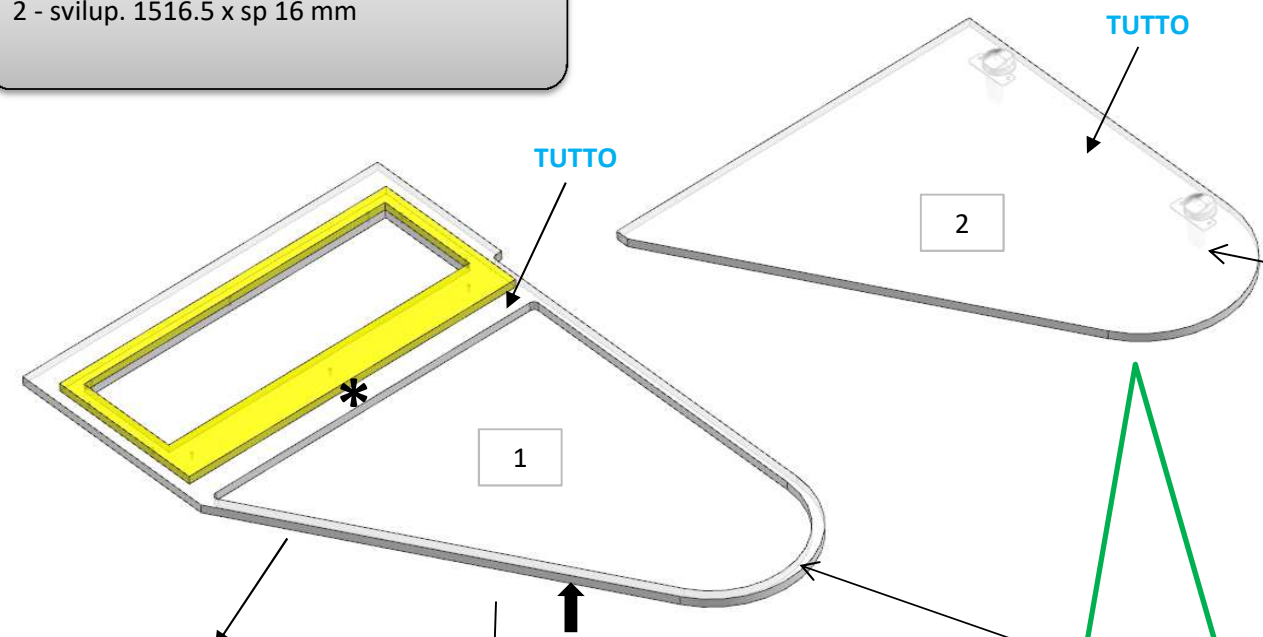

ELEMENTO DA MONTARE con:
MF-SG02
e spedire con un unico imballo

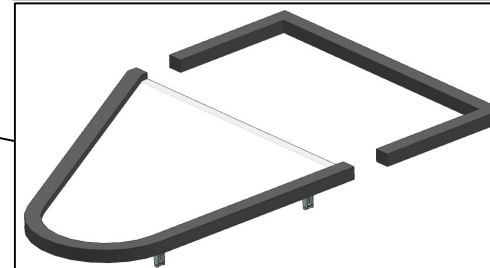

ELEMENTO DA MONTARE con:
MF-SG01
e spedire con un unico imballo

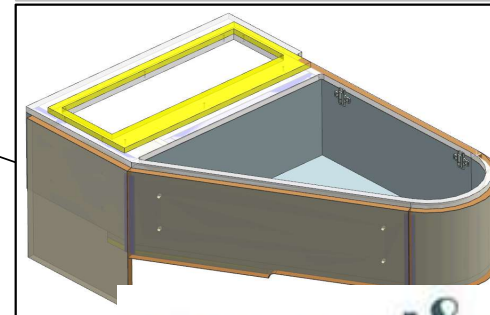

consonni&c

AZ68F

DA MAT. 216 REV. 29-04-2024

LOCALE	CODICE	DESCRIZIONE COMPONENTE	FINITURA	Q.TA	OPERATORE
SALONE	AZ68F-L02_SG01	CASSAPANCA SX	LACCATO MOGANO 100 GLOSS	2	Damiano

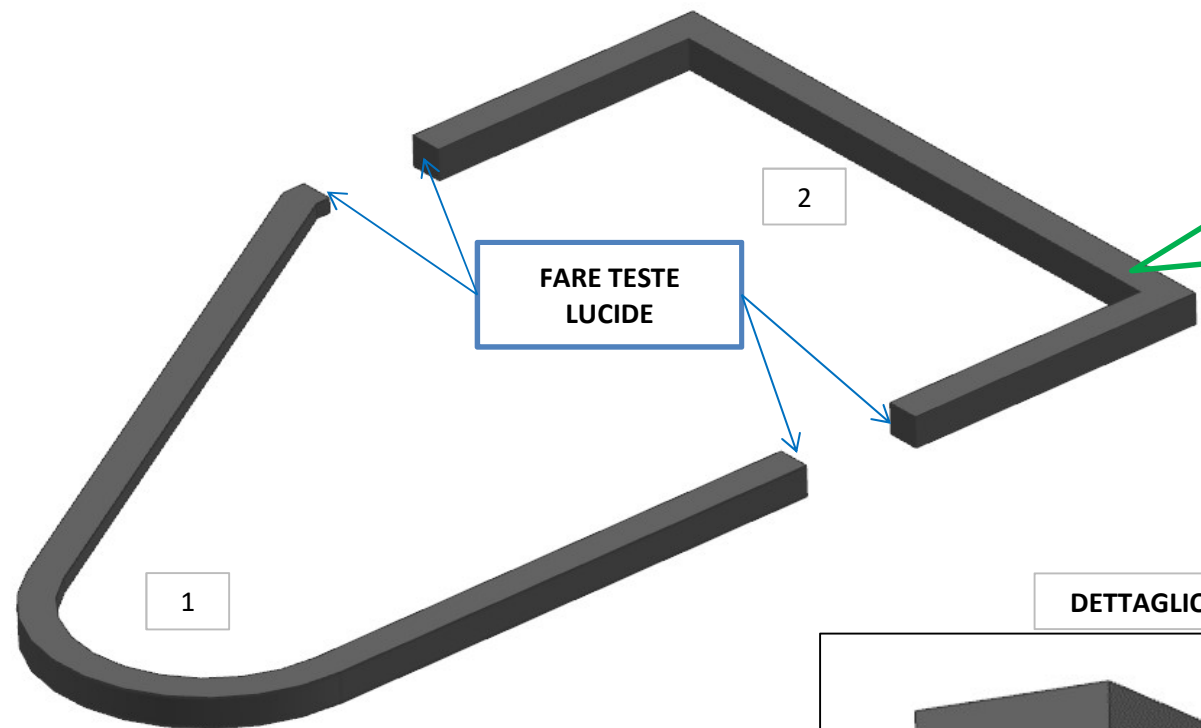

244
MODIFICATA SEZIONE.
PEZZO N.2 SENZA BATTUTA

ELEMENTO DA MONTARE con:
L01_SG01
e spedire con un unico imballo

1 - svilup. 1548 x sp 30 mm
2 - L 611 x H 292 x sp 30 mm

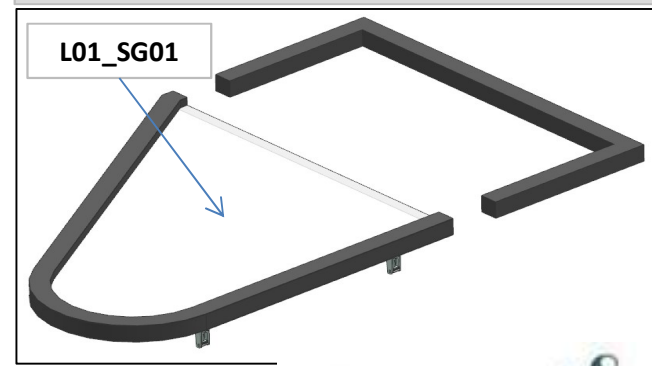
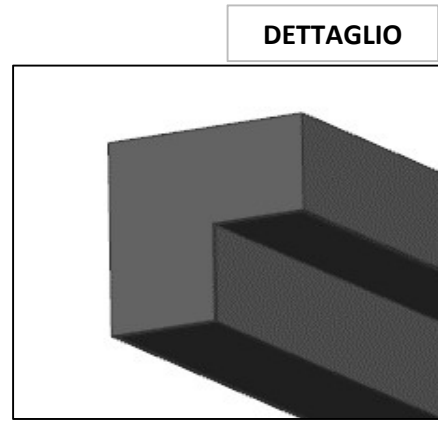

AZ68F

DA MAT. 203 REV. 29-04-2024

LOCALE	CODICE	DESCRIZIONE COMPONENTE	FINITURA	Q.TA	OPERATORE
SALONE	AZ68F-L01_SH01	COLONNA POPPA MURATA DX	LACCATO NERO OPACO	1	Damiano

1 - L 267 x H 987 x sp 10

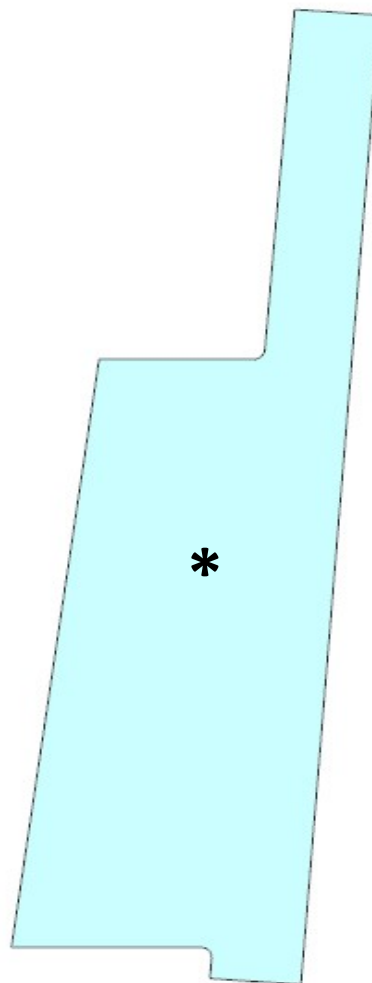

* faccia dove viene applicata la finitura
↓ filo dove viene applicata la finitura

AZ68F

DA MAT. 203 REV. 29-04-2024

LOCALE	CODICE	DESCRIZIONE COMPONENTE	FINITURA	Q.TA	OPERATORE
SALONE	AZ68F-L01_SL01	COLONNA PLENUM DX PRUA	LACCATO NERO OPACO	1	Damiano

1 - L 282 x H 987 x sp 10

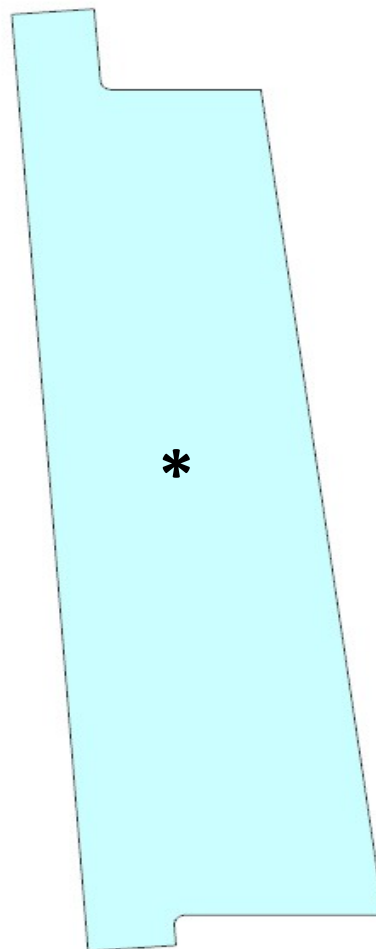

* faccia dove viene applicata la finitura
↓ filo dove viene applicata la finitura

AZ68F

DA MAT.265 REV. 29-04-2024

LOCALE	CODICE	DESCRIZIONE COMPONENTE	FINITURA	Q.TA	OPERATORE
SALONE	AZ68F-L01_SN01	SPES COPERTA GRADINO + DIVANI	LACCATO BRONZO	3	Damiano

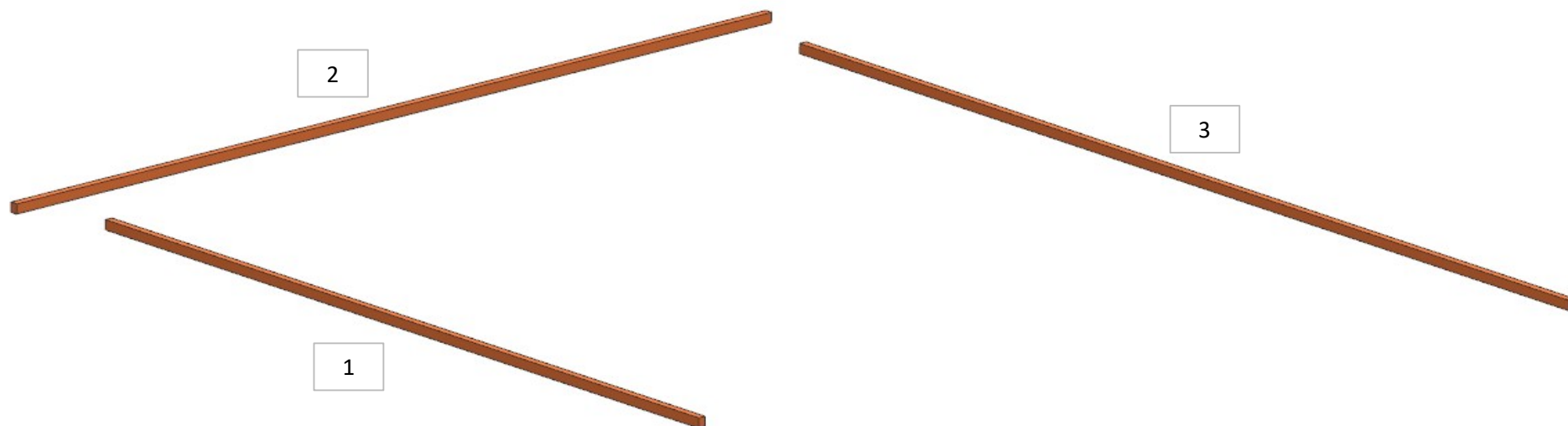

- 1 - L 1977 x H 27 x sp 19 mm
- 2 - L 2311 x H 27 x sp 19 mm
- 3 - L 2567 x H 27 x sp 19 mm

AZ68F

DA MAT. 201 REV. 29-04-2024

LOCALE	CODICE	DESCRIZIONE COMPONENTE	FINITURA	Q.TA	OPERATORE
SALONE	AZ68F-L01_SR01	COFFEE TABLE	LACCATO MOGANO 100 GLOSS	1	Damiano

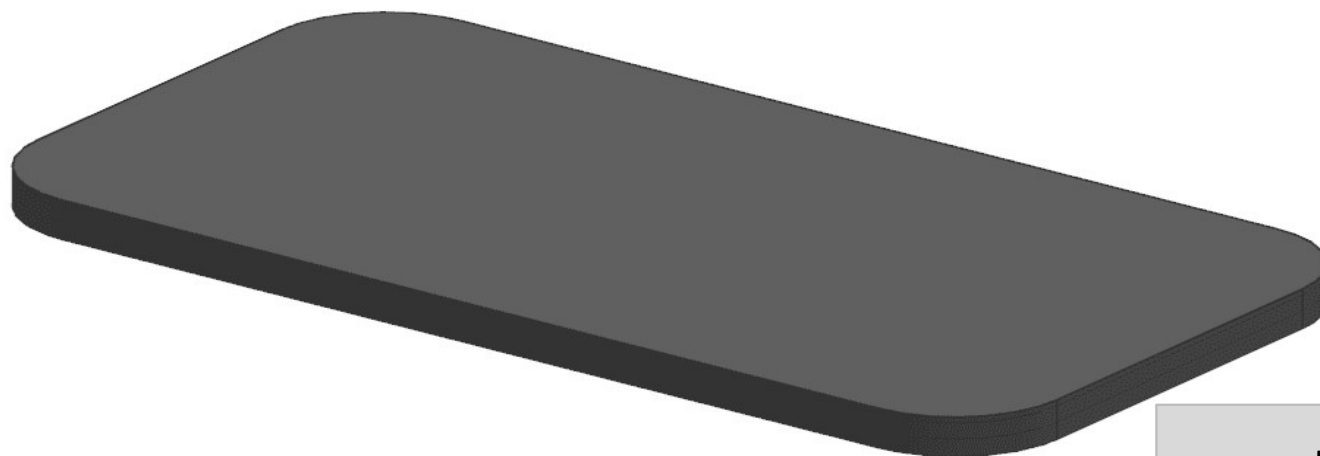

1 - L 1000 x H 520 x sp 37 mm

ELEMENTO DA MONTARE con:
A01_SR01
e spedire con un unico imballo

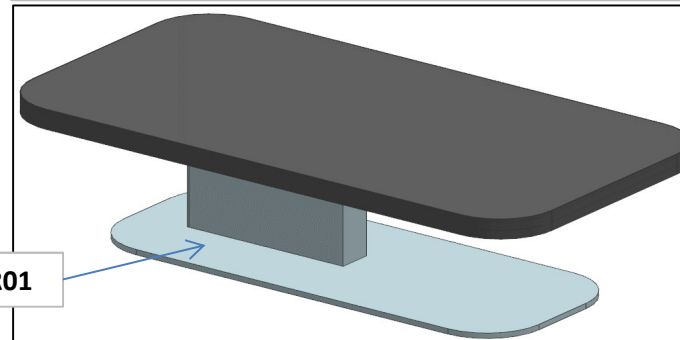

consonni&c

AZ68F

DA MAT. 201 REV. 29-04-2024

LOCALE	CODICE	DESCRIZIONE COMPONENTE	FINITURA	Q.TA	OPERATORE
SALONE	AZ68F-L01_SS01	STRUTTURA DIVANO	LACCATO MOGANO 100 GLOSS	3	Damiano

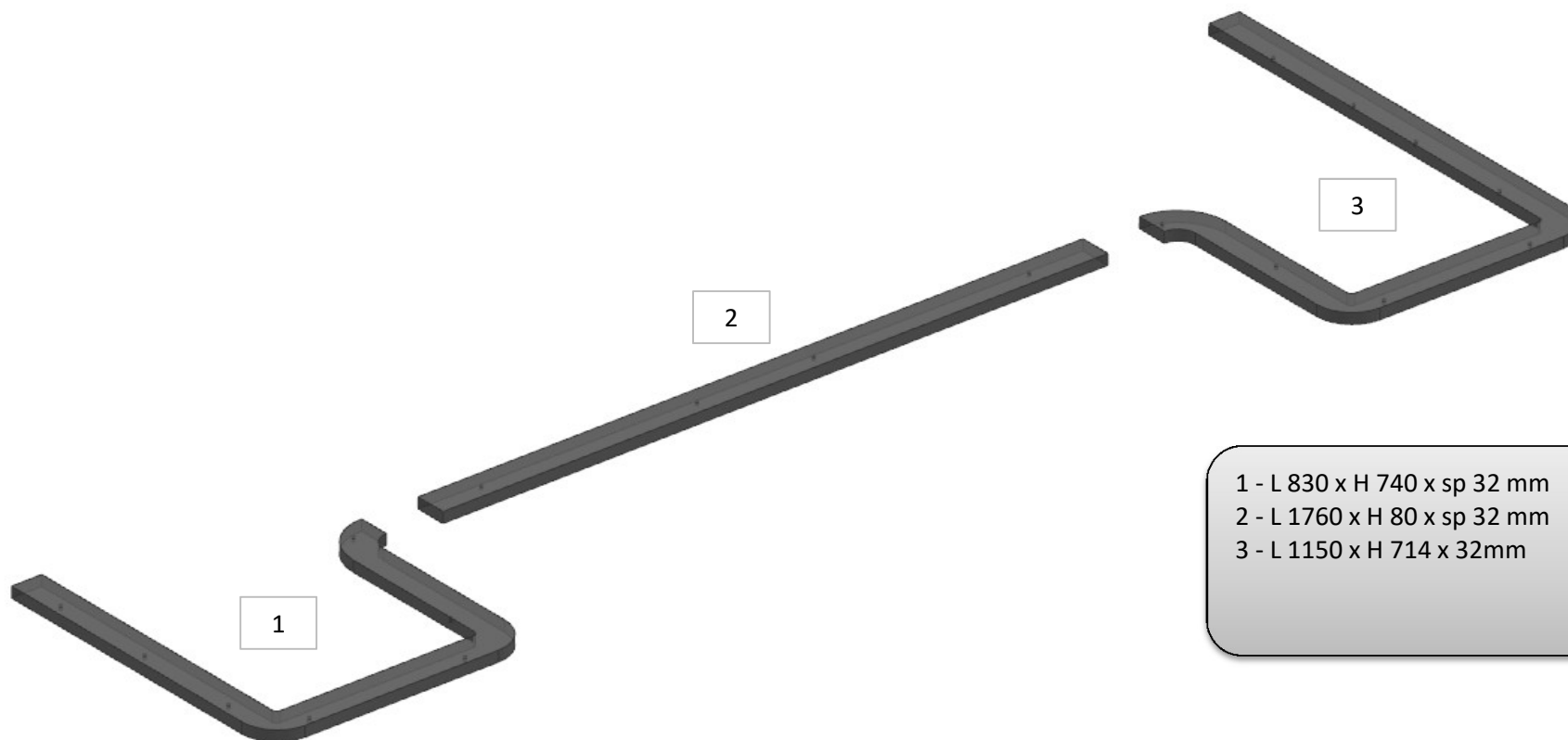

- 1 - L 830 x H 740 x sp 32 mm
- 2 - L 1760 x H 80 x sp 32 mm
- 3 - L 1150 x H 714 x 32mm

AZ68F

DA MAT. 201 REV. 29-04-2024

LOCALE	CODICE	DESCRIZIONE COMPONENTE	FINITURA	Q.TA	OPERATORE
SALONE	AZ68F-L01_ST01	CORNICE TV OPT	LACCATO BRONZO	5	Damiano

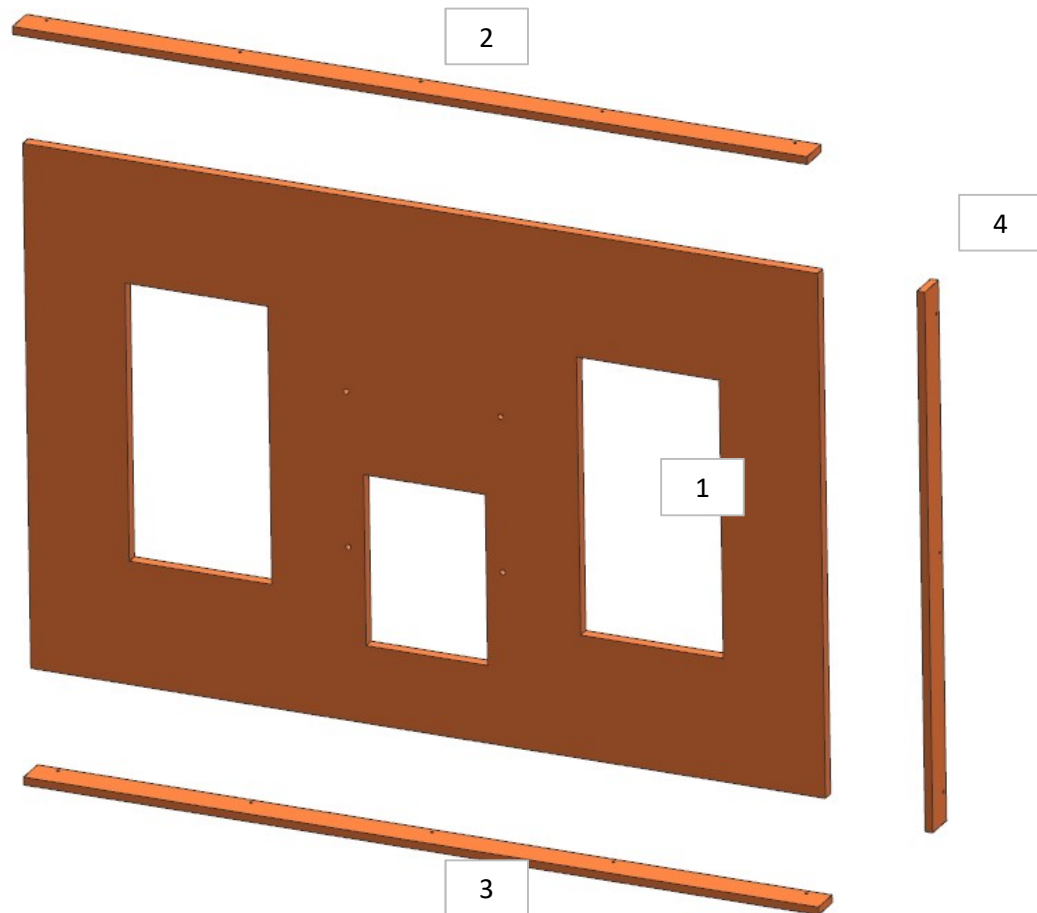

1 - L 1029 x H 675 x 15 mm
2/3 - L 1029 x H 40 x 10 mm
4/5 - L 695 x H 40 x 10mm

**ELEMENTO DA MONTARE:
MG_ST01
e spedire con un unico imballo**

