

AZ68F

REV. 29-04-2024

LOCALE	CODICE	DESCRIZIONE COMPONENTE	FINITURA	Q.TA	OPERATORE
SALONE A POPPA	AZ68F-SSA01	PARETE DIVISORIA LATO POPPA	OKOUME' GREZZO	2	Dante

1 - L.1515 x H.1729 x sp 15
2 - L.577 x H.318 x sp 30

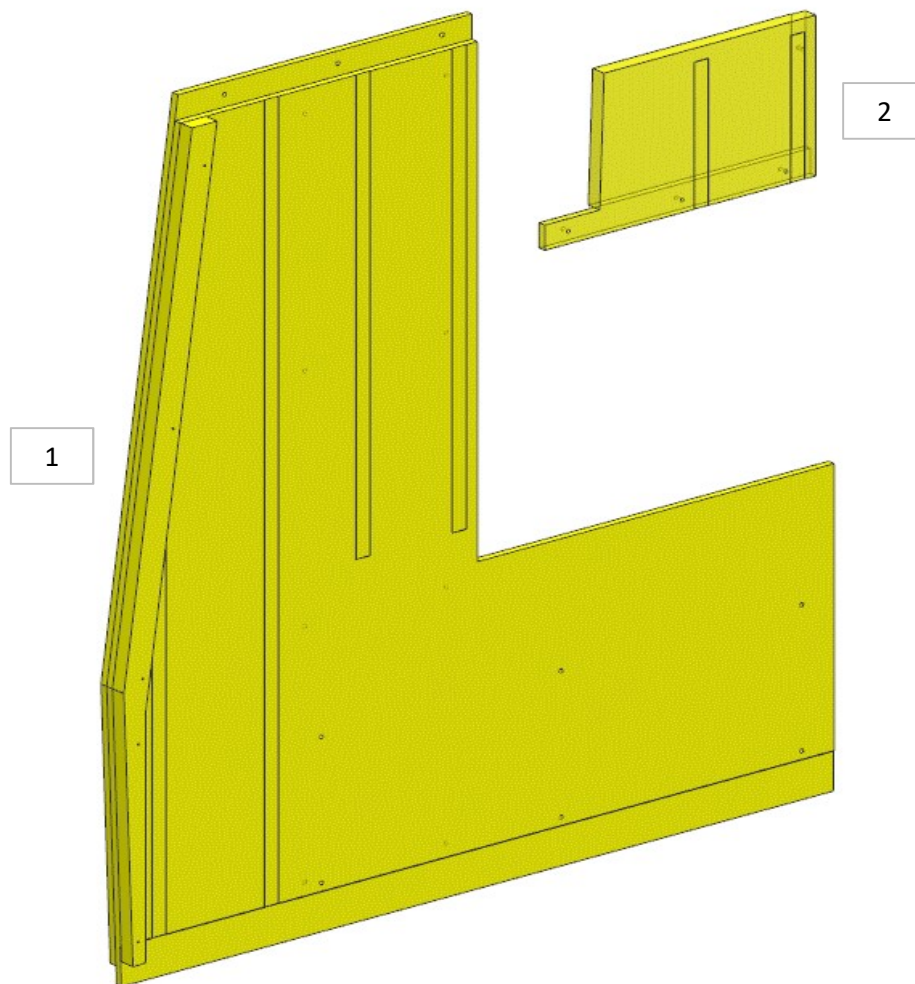

FERRAMENTA:

N° 6 - FITLOCK MASCHIO
N° 6 - FITLOCK FEMMINA
N° 20 - BUSSOLA ZAMA 6MA

AZ68F

DA MAT. 265 REV. 29-04-2024

LOCALE	CODICE	DESCRIZIONE COMPONENTE	FINITURA	Q.TA	OPERATORE
SALONE A POPPA	AZ68F-SSC01	MURATA BASSA DX PRUA	OKOUME\GREZZO VER. ANTI ROMBO	4	Damiano

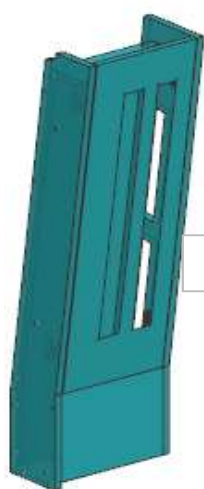

3

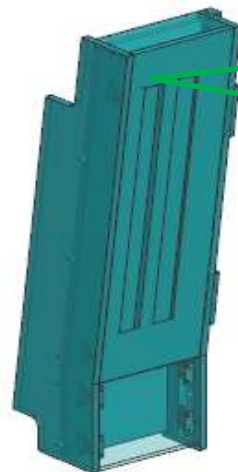

4

MOD. INT.
PLENUM DIVISO DA STRUTTURA.
VERNICIARE CON ANTI-ROMBO

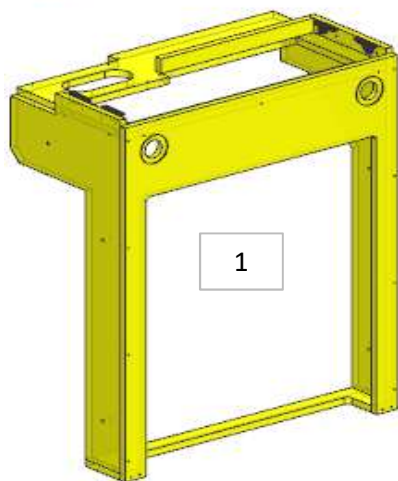

1

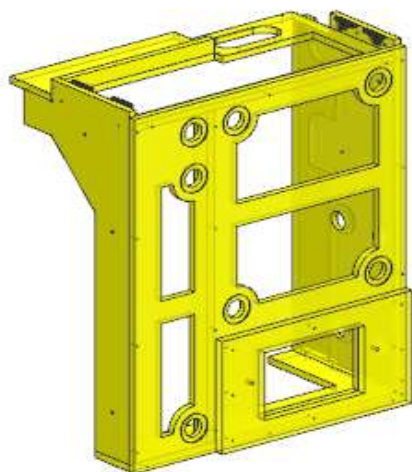

2

FERRAMENTA:

- N° 20 - KEKU FRONTALE
- N° 6 - BUSSOLA ZAMA 6MA
- N° 15 - VITI 6MA
- N° 13 - FITLOCK MASCHIO
- N° 13 - FITLOCK FEMMINA

AZ68F

REV. 29-04-2024

LOCALE	CODICE	DESCRIZIONE COMPONENTE	FINITURA	Q.TA	OPERATORE
SALONE A POPPA	AZ68F-SSD01	MURATA BASSA TV	LAMINATO NADIR	1	Damiano

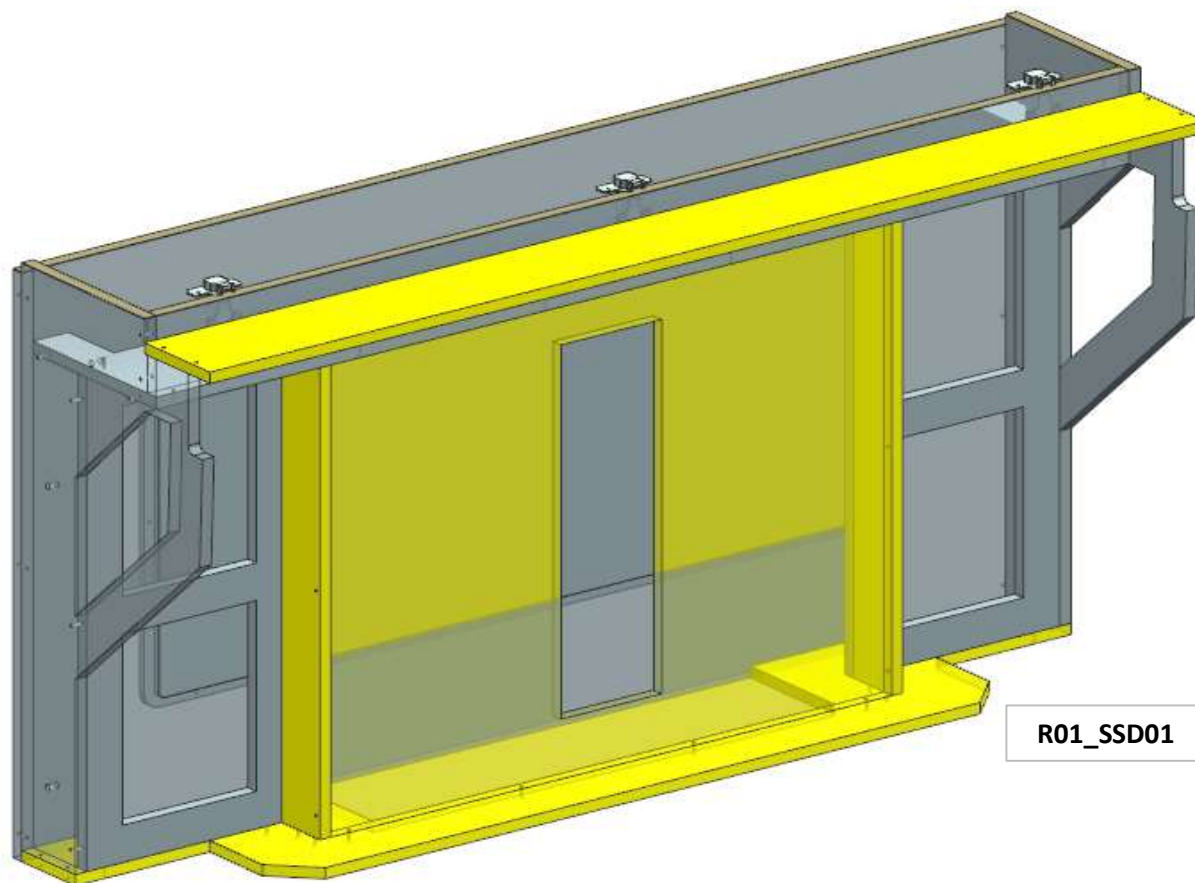

FERRAMENTA:

- N° 3 - CERNIERA PIANA SENZA MOLLA
- N° 3 - BASETTA H6
- N° 12 - ANKOR BORGHI
- N° 2 - GOMMINO PARACOLPI
- N° 6 - BUSSOLA ZAMA 6MA

ELEMENTO DA MONTARE:

R01-SSD01

e spedire con un unico imballo

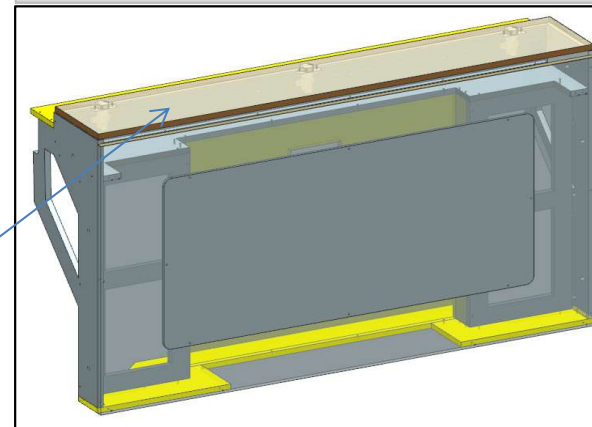

AZ68F

DA MAT. 203 REV. 29-04-2024

LOCALE	CODICE	DESCRIZIONE COMPONENTE	FINITURA	Q.TA	OPERATORE
SALONE A POPPA	AZ68F-SSE01	CASSAPANCA DX	LAMINATO NADIR	1	Damiano

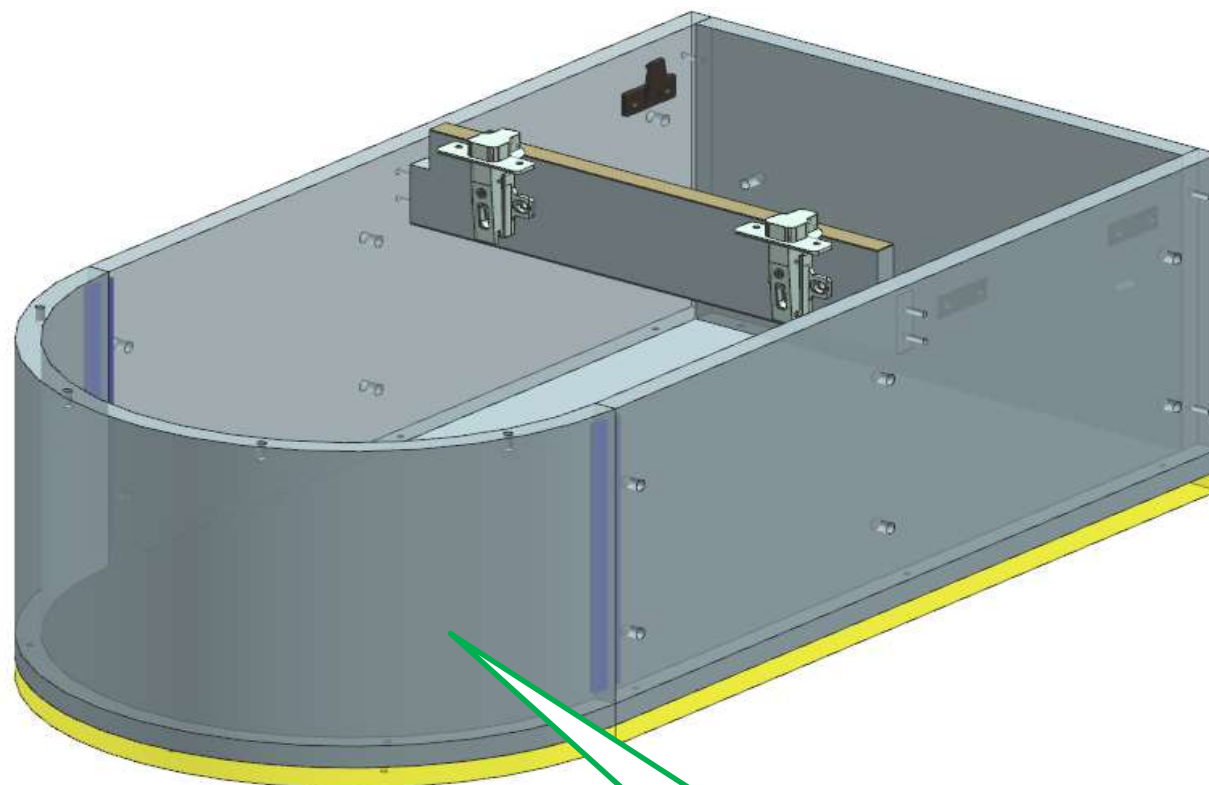

CURVA IN UN PEZZO SOLO

- FERRAMENTA:**
- N° 2 - CERNIERA MEZZO COLLO 40mm
 - N° 2 - BASETTA H0
 - N° 8 - ANKOR BORGHI
 - N° 2 - GOMMINO PARACOLPI
 - N° 4 - KEKU FRONTALE
 - N° 2 - VITI 6MA
 - N° 12 - BUSSOLA ZAMA 6MA
 - N° 1 - BRACCETTO A CIPOLLA

ELEMENTO DA MONTARE:
R01-SSE01
L01-SSE01
 e spedire con un unico imballo

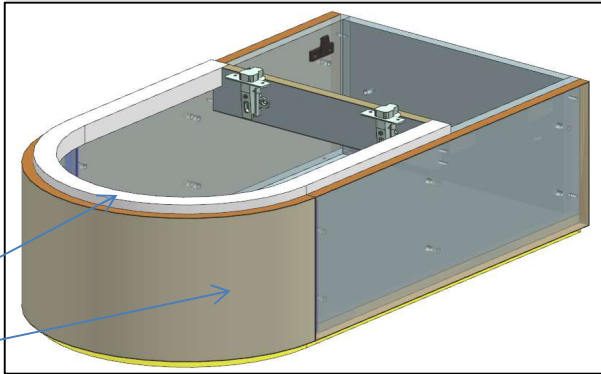

L01_SSE01
 R01_SSE01

AZ68F

DA MAT.233

REV. 29-04-2024

LOCALE	CODICE	DESCRIZIONE COMPONENTE	FINITURA	Q.TA	OPERATORE
SALONE A POPPA	AZ68F-SSF01	COLONNA PLENUM DX PRUA	OKOUME\GREZZO VER. ANTI ROMBO	2	Dante

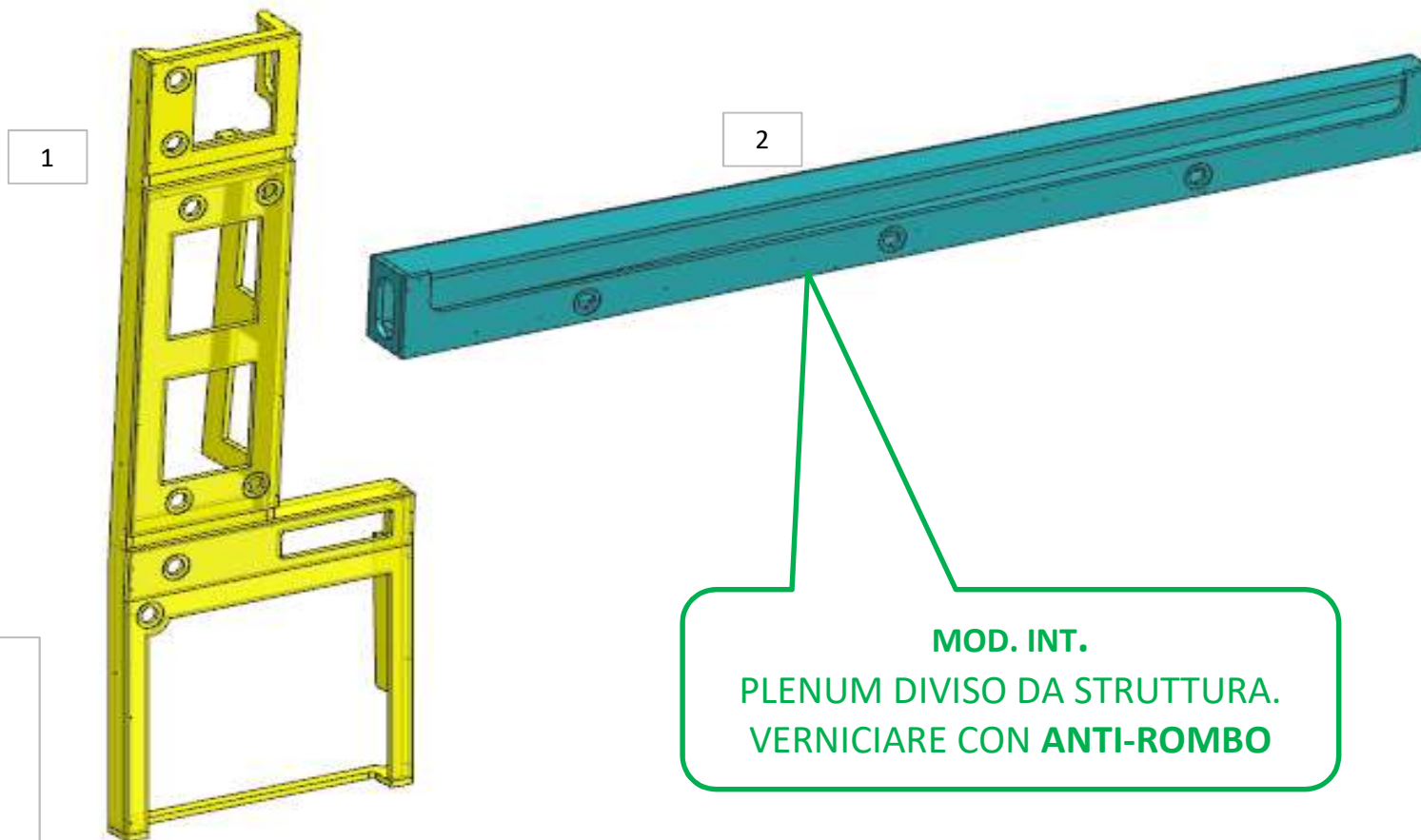

FERRAMENTA:

- N° 2 - BUSSOLA ZAMA 6MA
- N° 6 - VITI 6MA
- N° 10 - FITLOCK MASCHIO
- N° 10 - FITLOCK FEMMINA

AZ68F

DA MAT.212 REV. 29-04-2024

LOCALE	CODICE	DESCRIZIONE COMPONENTE	FINITURA	Q.TA	OPERATORE
SALONE A POPPA	AZ68F-SSG01	STRUTTURA MURATA BASSA DX	OKOUME' GREZZO	1	Dante

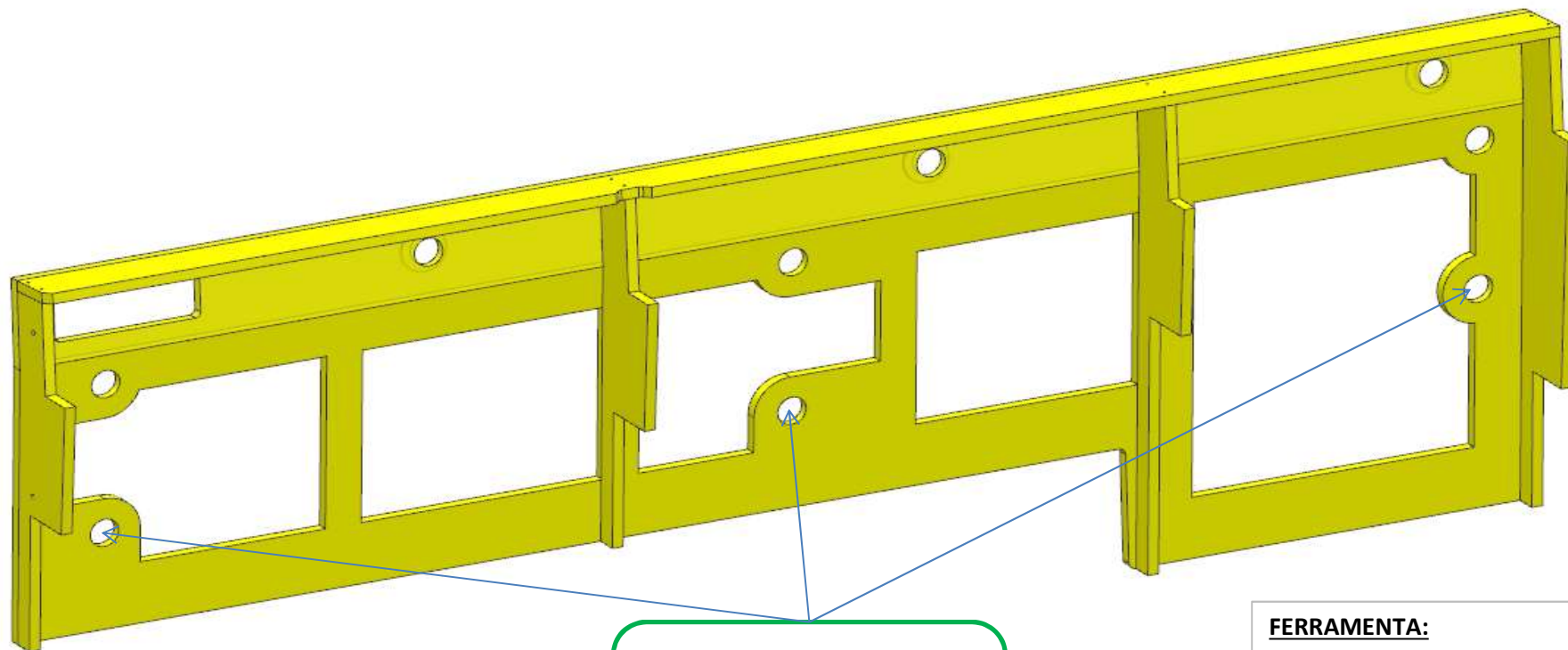

25 (step1)
AGGIUNTI FORI
FITLOCK

FERRAMENTA:

- N° 2 - BUSSOLA ZAMA 6MA
- N° 2 - VITI 6MA
- N° 3 - FITLOCK MASCHIO
- N° 3 - FITLOCK FEMMINA

AZ68F

DA MAT. 203 REV. 29-04-2024

LOCALE	CODICE	DESCRIZIONE COMPONENTE	FINITURA	Q.TA	OPERATORE
SALONE A POPPA	AZ68F-SSH01	COLONNA POPPA MURATA DX	OKOUME' GREZZO	1	Dante

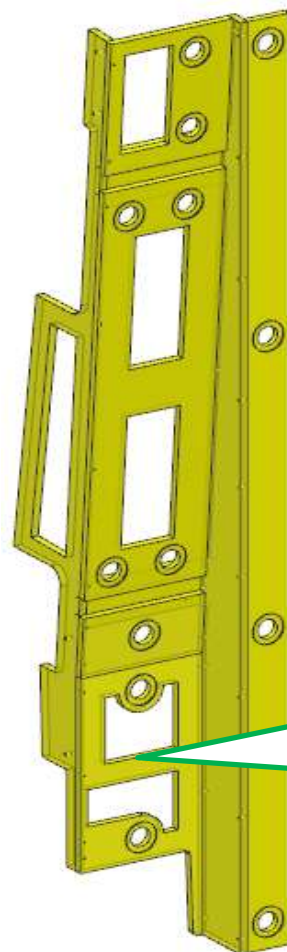

1-2
MODIFICATA
STRUTTURA E
AGGIUNTO
FITLOCK PER
NUOVO
IMPOTTITO

FERRAMENTA:

- N° 2 - BUSSOLA ZAMA 6MA
- N° 2 - VITI 6MA
- N° 13 - FITLOCK MASCHIO
- N° 13 - FITLOCK FEMMINA

AZ68F

DA MAT. 212 REV. 29-04-2024

LOCALE	CODICE	DESCRIZIONE COMPONENTE	FINITURA	Q.TA	OPERATORE
SALONE A POPPA	AZ68F-SSI01	GRADINO ALTO	OKOUME' GREZZO	2	Damiano

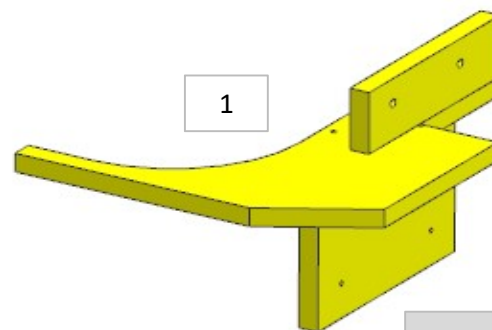
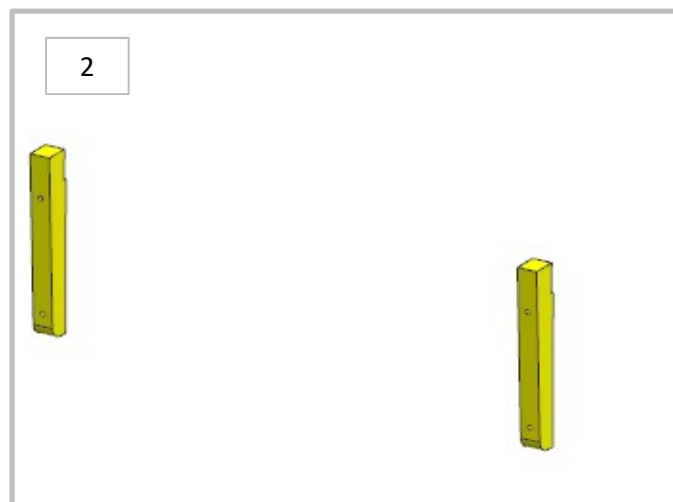

2 - N° 2 PZ. = L.21 x H 150 x sp 15mm

FERRAMENTA:

N° 2 - VITI 6MA

**ELEMENTO DA MONTARE:
R01-SSI01
e spedire con un unico imballo**

R01_SSI01

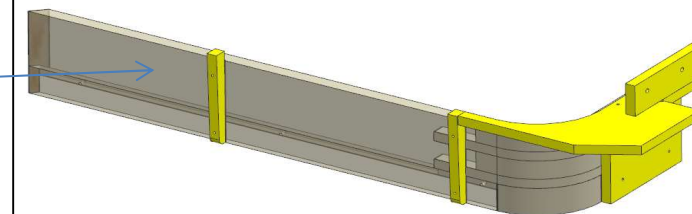

AZ68F

DA MAT. 265 REV. 29-04-2024

LOCALE	CODICE	DESCRIZIONE COMPONENTE	FINITURA	Q.TA	OPERATORE
SALONE A POPPA	AZ68F-SSM01	MURATA BASSA SX PRUA	OKOUME\GREZZO VER. ANTI ROMBO	3	Damiano

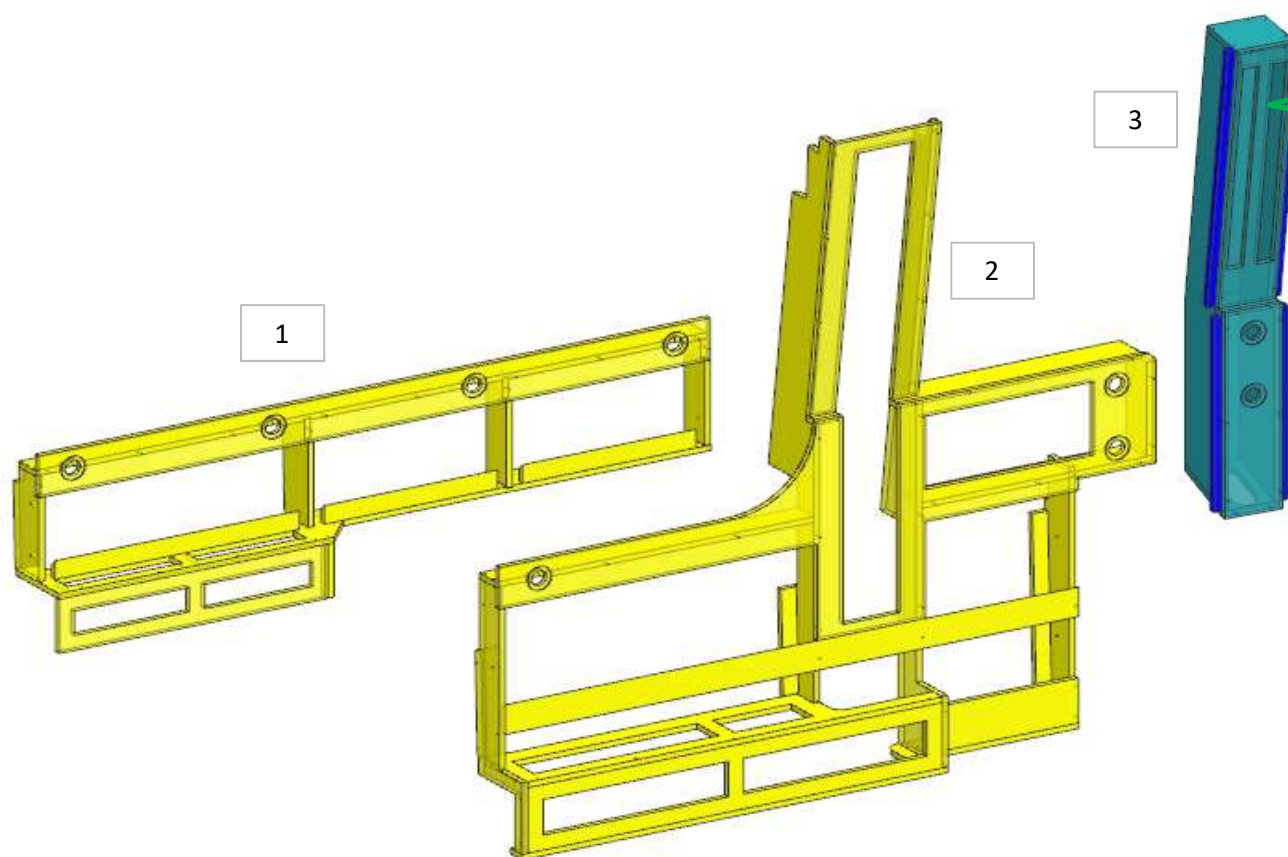

MOD. INT.
PLENUM DIVISO DA
STRUTTURA.
VERNICIARE CON
ANTI-ROMBO

FERRAMENTA:

- N° 2 - BUSSOLA ZAMA 6MA
- N° 4 - VITI 6MA
- N° 9 - FITLOCK MASCHIO
- N° 9 - FITLOCK FEMMINA

AZ68F

DA MAT. 203 REV. 29-04-2024

LOCALE	CODICE	DESCRIZIONE COMPONENTE	FINITURA	Q.TA	OPERATORE
SALONE A POPPA	AZ68F-SSR01	DIVANO POPPA	OKOUME' GREZZO	1	Damiano

L. 456 x H. 65 x pr. 73mm

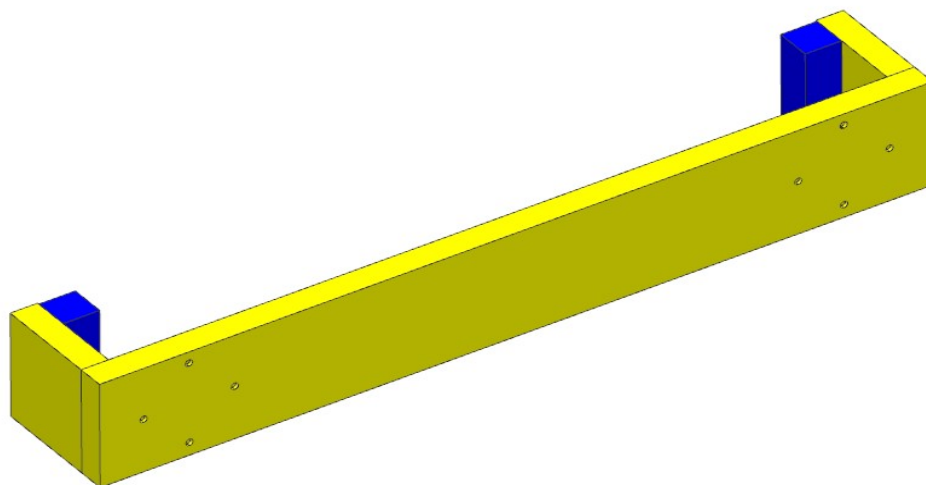

FERRAMENTA:

N° 2 - FITLOCK MASCHIO
N° 2 - FITLOCK FEMMINA

ELEMENTO DA MONTARE con:
R01_SSR01
e spedire con un unico imballo

R01_SSR01

