

AZ68F

DA MAT. 233 REV. 18-10-2022

LOCALE	CODICE	DESCRIZIONE COMPONENTE	FINITURA	Q.TA	OPERATORE
SALONE A POPPA	AZ66F-L01_SSB01	LANTERNA DIVISORIA PRUA	LACCATO BRONZO	1	Damiano

1 - L.765 x H.29 x sp 35

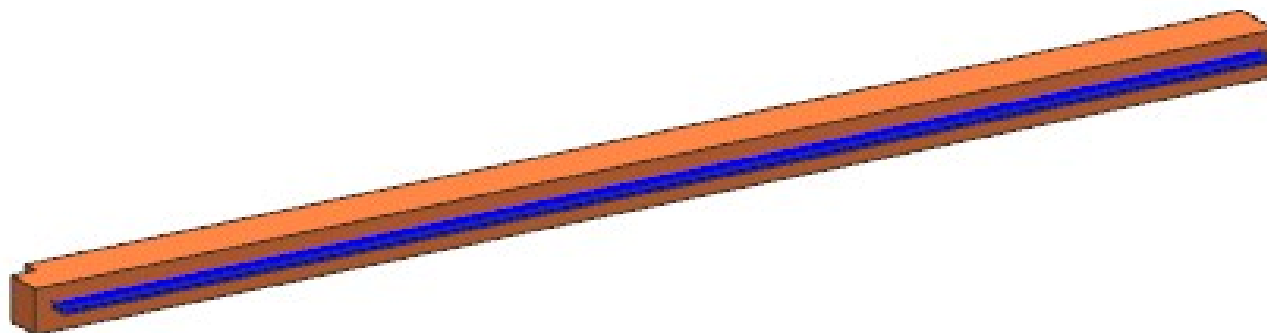

**ELEMENTO DA
MONTARE con:
R01_SSB01
A01_SSB01
e spedire con un unico
imballo**

A01_SSB01

R01_SSB01

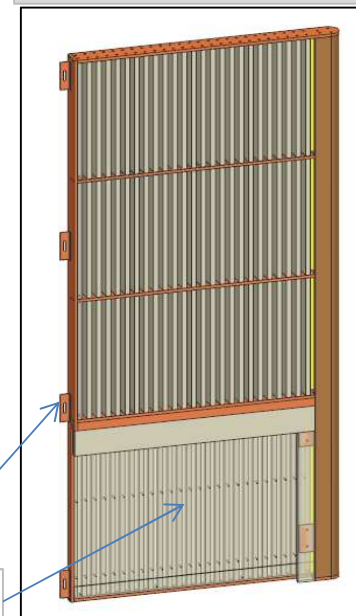

consonni&c

AZ68F

DA MAT. 203 REV. 18-10-2022

LOCALE	CODICE	DESCRIZIONE COMPONENTE	FINITURA	Q.TA	OPERATORE
SALONE A POPPA	AZ66F-L01_SSC01	MURATA BASSA DX PRUA	LACCATO NERO OPACO	2	Damiano

1 - 2 - L 260 x H.952 x sp 10

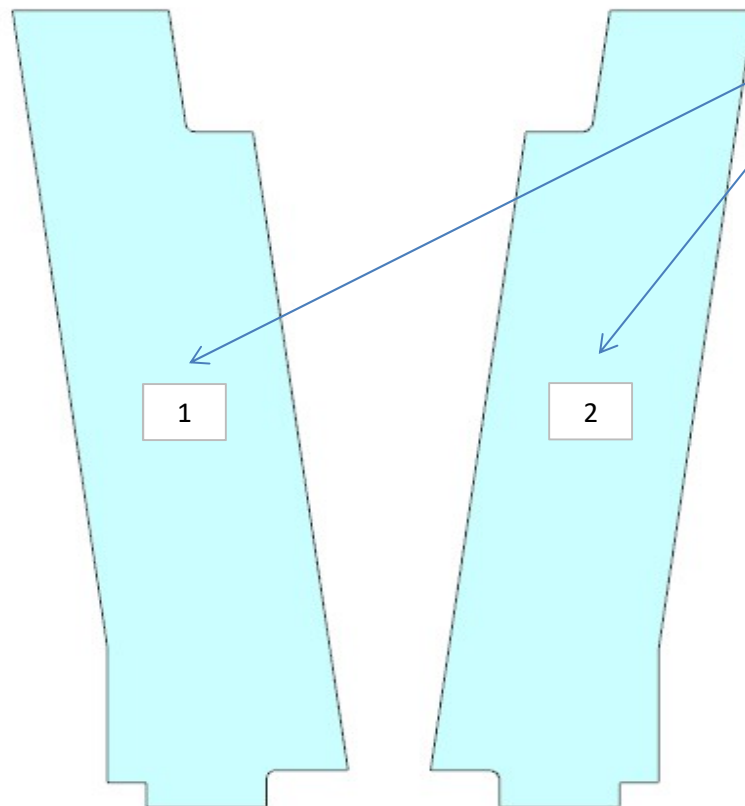

LATO BELLO

AZ68F

DA MAT. 203 REV. 18-10-2022

LOCALE	CODICE	DESCRIZIONE COMPONENTE	FINITURA	Q.TA	OPERATORE
SALONE A POPPA	AZ66F-L01_SSE01	CASSAPANCA DX	LACCATO BIANCO ARTICO	3	Damiano

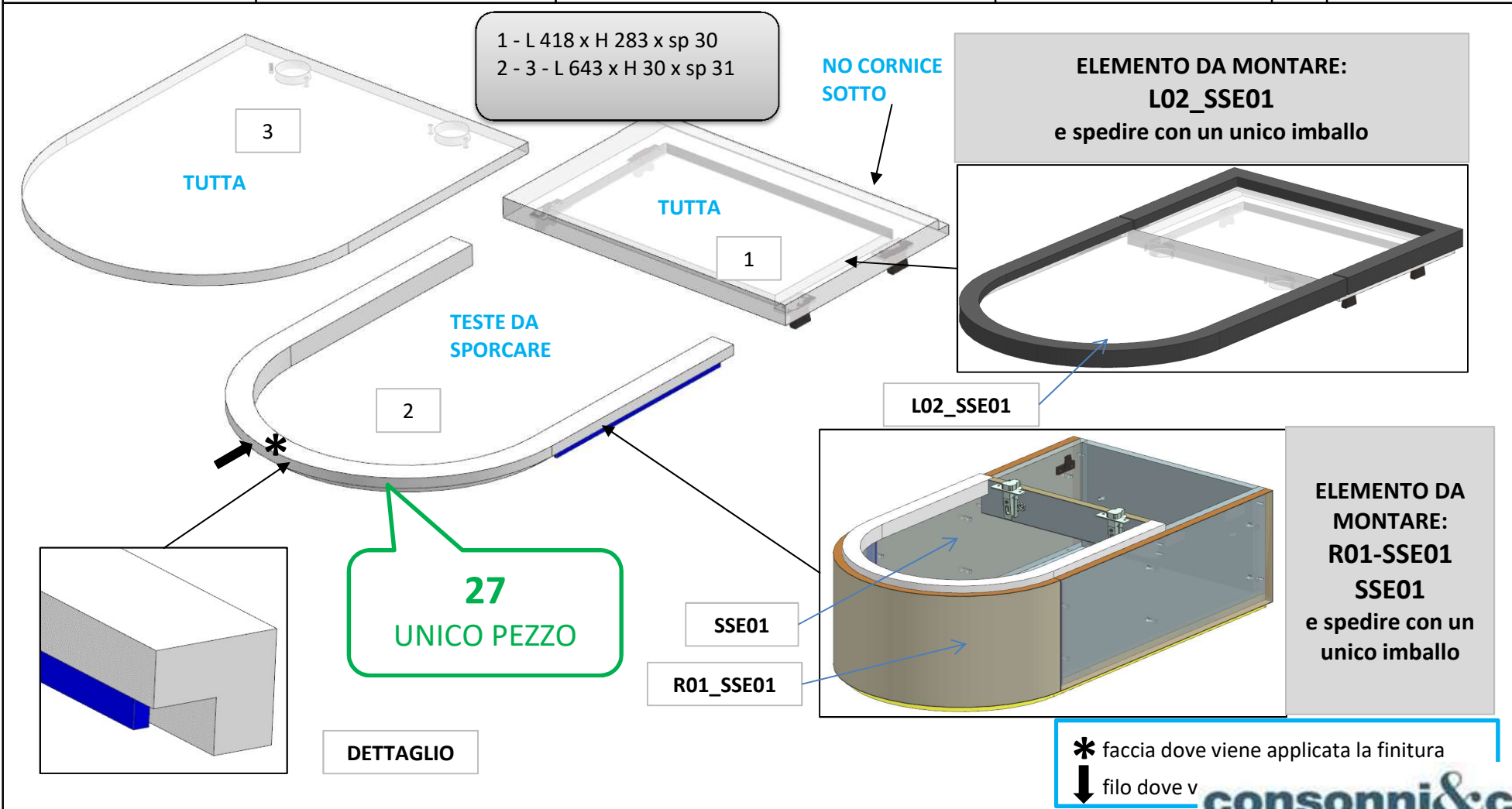

AZ68F

DA MAT. 203 REV. 18-10-2022

LOCALE	CODICE	DESCRIZIONE COMPONENTE	FINITURA	Q.TA	OPERATORE
SALONE A POPPA	AZ66F-L02_SSE01	CASSAPANCA DX	LACCATO MOGANO 100 GLOSS	2	Damiano

1 - L.450 x H 30 x sp 30
2 - SVILUPPO: L.1331 x H 283 x sp 30

DETTAGLIO

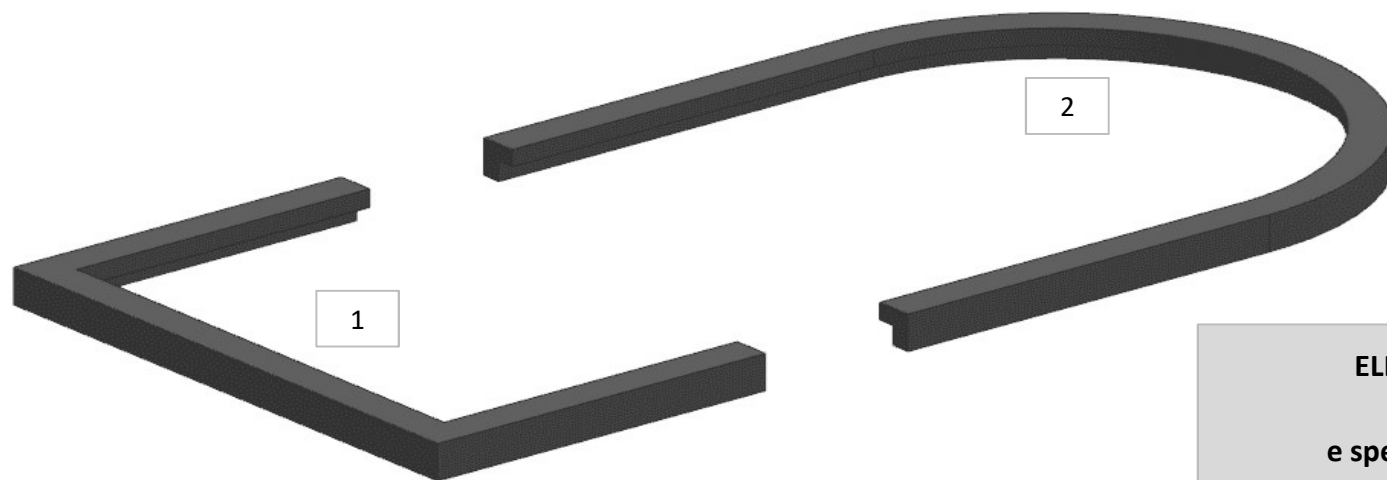
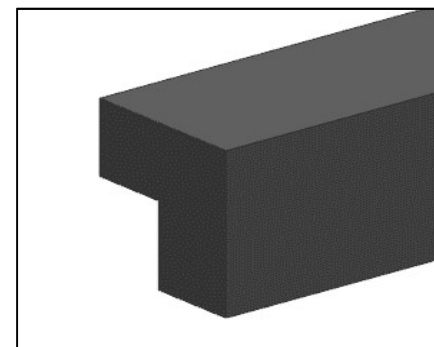

ELEMENTO DA MONTARE:
L01_SSE01
e spedire con un unico imballo

L01_SSE01

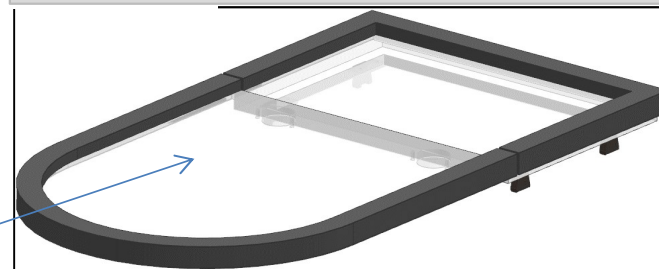

consonni&c

AZ68F

REV. 18-10-2022

LOCALE	CODICE	DESCRIZIONE COMPONENTE	FINITURA	Q.TA	OPERATORE
SALONE A POPPA	AZ66F-L01_SSF01	COLONNA PLENUM DX PRUA	LACCATO NERO OPACO	1	Damiano

1 - L.282 x H 990 x sp 10

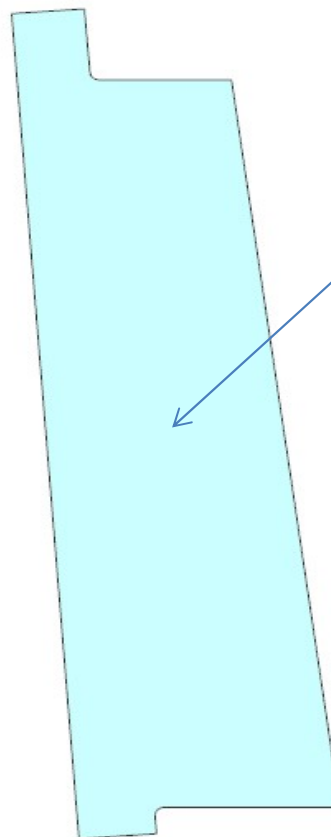

LATO BELLO

AZ68F

REV. 18-10-2022

LOCALE	CODICE	DESCRIZIONE COMPONENTE	FINITURA	Q.TA	OPERATORE
SALONE A POPPA	AZ66F-L01_SSH01	COLONNA POPPA MURATA DX	LACCATO NERO OPACO	1	Damiano

1 - L. 266 x H.990 x sp 10

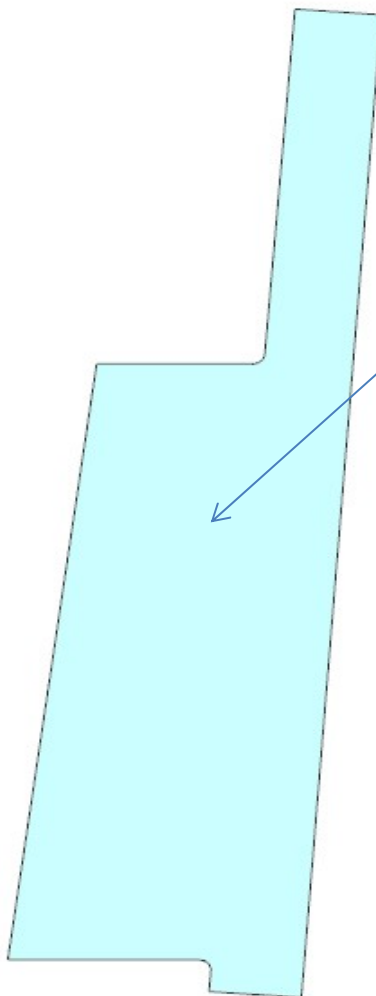

LATO BELLO

AZ68F

DA MAT. 211 REV. 18-10-2022

LOCALE	CODICE	DESCRIZIONE COMPONENTE	FINITURA	Q.TA	OPERATORE
SALONE A POPPA	AZ66F-L01_SSL01	MANTOVANA DX PRUA	LACCATO BIANCO ARTICO	2	Damiano

1 - L.2091 x H.180 x 42
2 - L.2091 x H.69 x sp 15

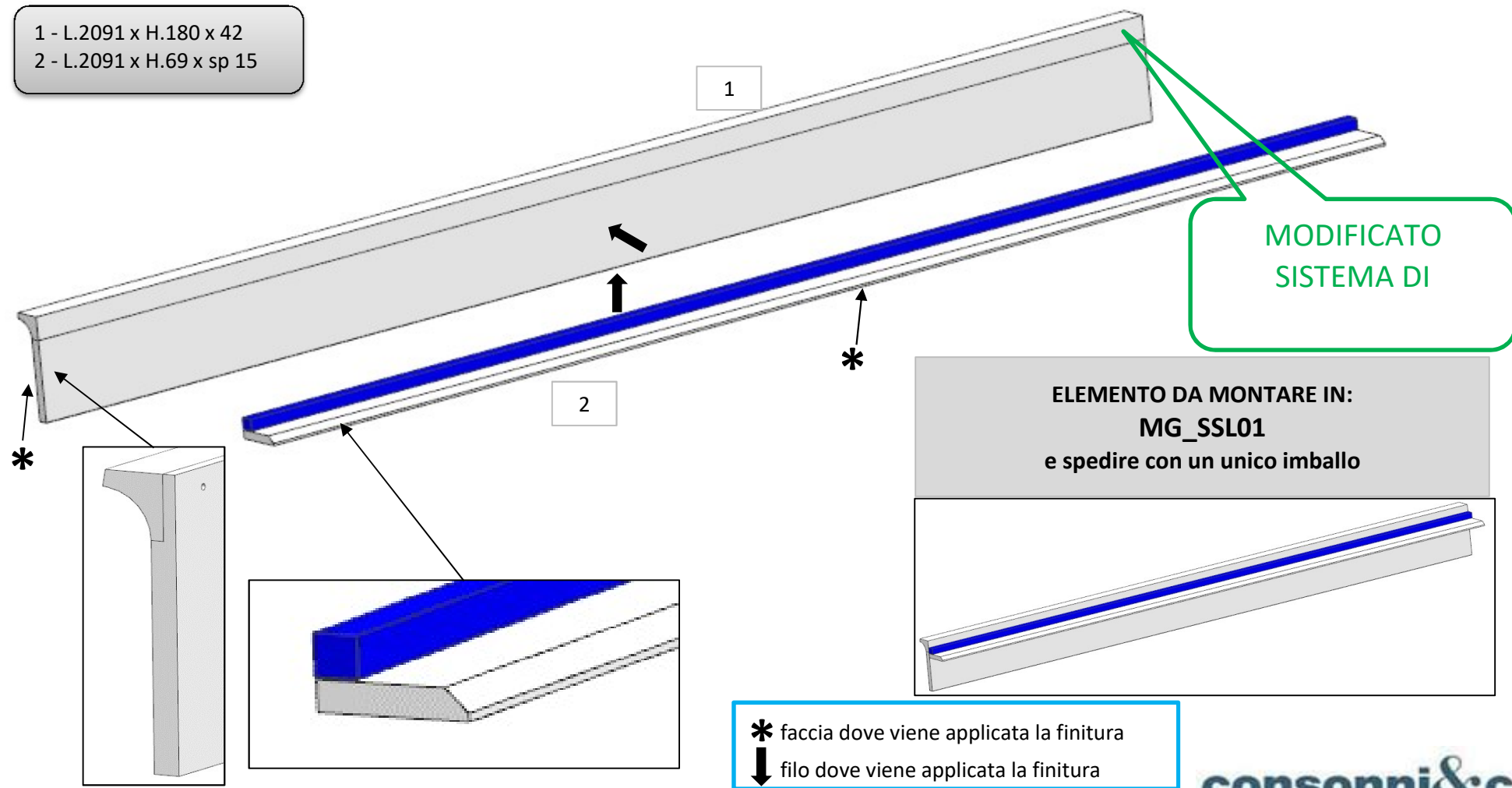

consonni&c

AZ68F

DA MAT. 203 REV. 18-10-2022

LOCALE	CODICE	DESCRIZIONE COMPONENTE	FINITURA	Q.TA	OPERATORE
SALONE A POPPA	AZ66F-L01_SSM01	MURATA BASSA SX PRUA	LACCATO NERO OPACO	2	Damiano

1 - L.200 x H.1019 x sp 10mm
2 - L.167 x H.753 x sp 10mm

LATO BELLO

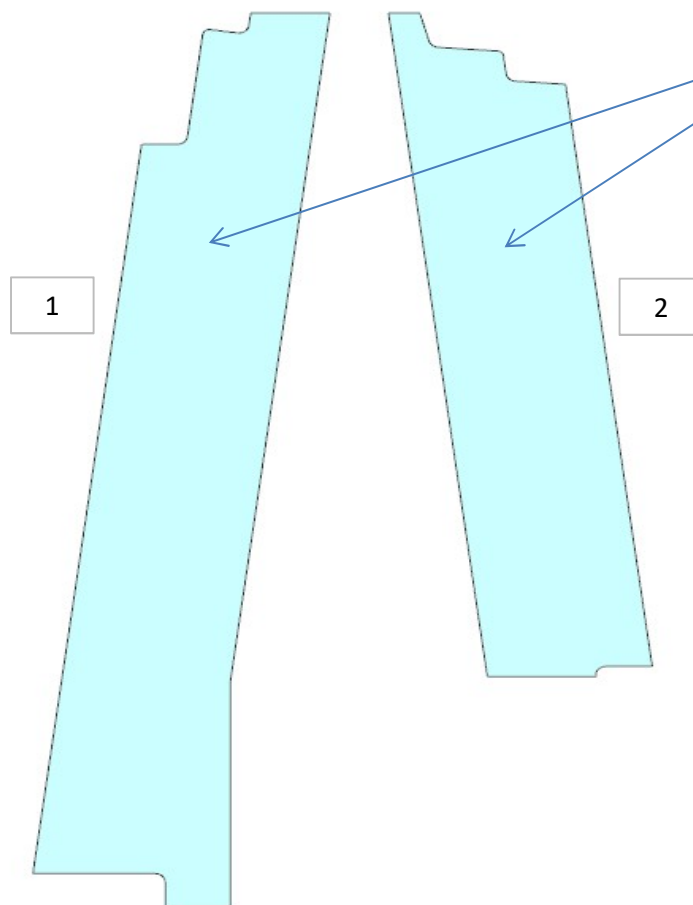

AZ68F

DA MAT. 211 REV. 18-10-2022

LOCALE	CODICE	DESCRIZIONE COMPONENTE	FINITURA	Q.TA	OPERATORE
SALONE A POPPA	AZ66F-L01_SSN01	MANTOVANA SX PRUA	LACCATO BIANCO ARTICO	2	Damiano

* faccia dove viene applicata la finitura
 ↓ filo dove viene applicata la finitura

1 - L.2538 x H 180 x sp 15
 2 - L.2537 x H 80 x sp 15

1

2

MODIFICATO SISTEMA DI

ELEMENTO DA MONTARE IN:
 MG_SSN01
 e spedire con un unico imballo

AZ68F

DA MAT. 203 REV. 18-10-2022

LOCALE	CODICE	DESCRIZIONE COMPONENTE	FINITURA	Q.TA	OPERATORE
SALONE A POPPA	AZ66F-L01_SSQ01	DIVANO PRUA	LACCATO MOGANO 100 GLOSS	3	Damiano

- 1 - L.864 x H 32 x pr 1150mm
- 2 - L.1488 x H 32 x sp 80mm
- 3 - L.861 x H 32 x pr 830mm

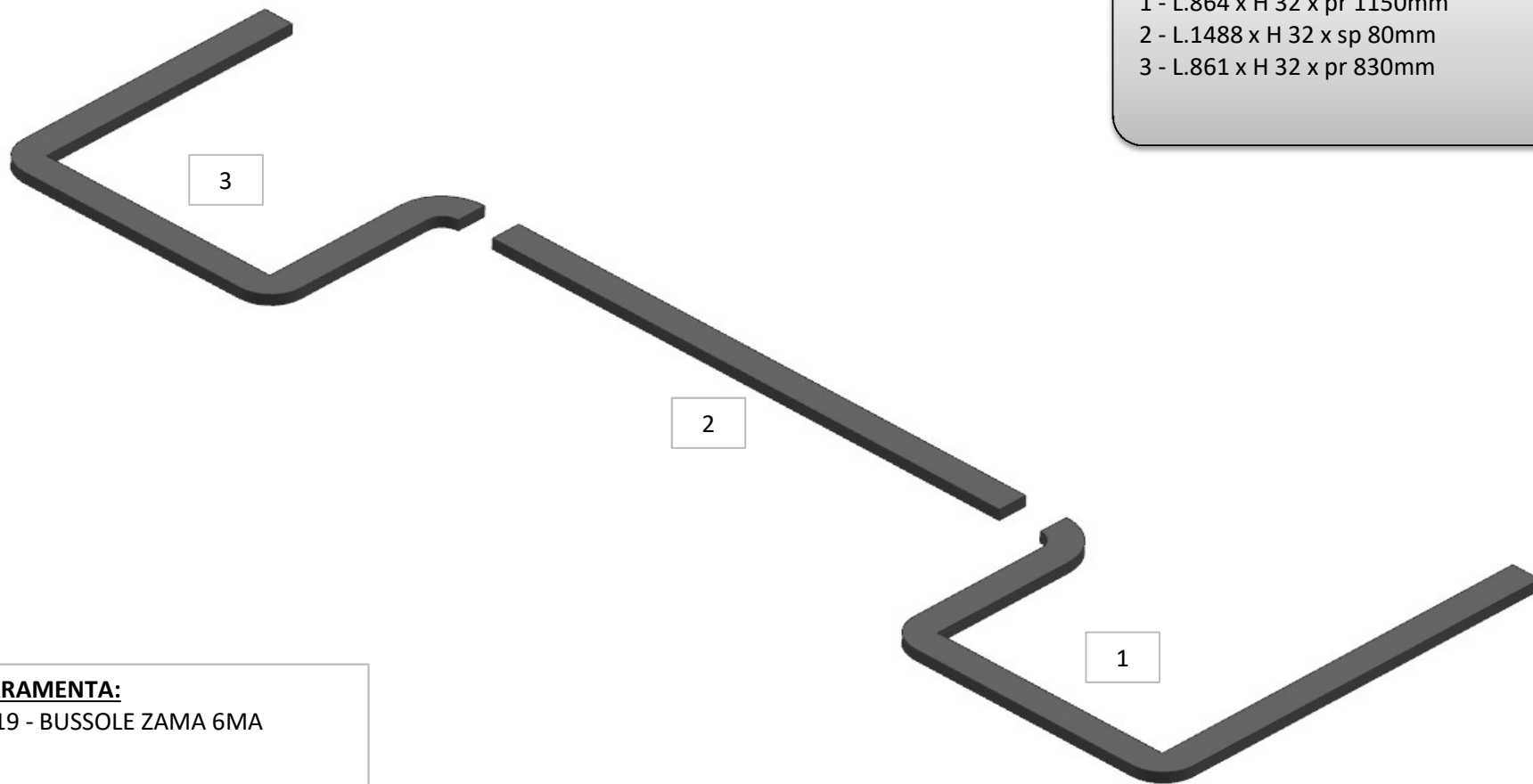

FERRAMENTA:
N° 19 - BUSSOLE ZAMA 6MA

AZ68F

DA MAT. 203 REV. 18-10-2022

LOCALE	CODICE	DESCRIZIONE COMPONENTE	FINITURA	Q.TA	OPERATORE
SALONE A POPPA	AZ66F-L01_SSR01	DIVANO POPPA	LACCATO MOGANO 100 GLOSS	2	Damiano

1 - L.720 x H 32 x pr. 589mm
2 - L.2000 x H 32 x sp 32mm



FERRAMENTA:
N° 8 - BUSSOLE ZAMA 6MA

AZ68F

DA MAT. 203 REV. 18-10-2022

LOCALE	CODICE	DESCRIZIONE COMPONENTE	FINITURA	Q.TA	OPERATORE
SALONE A POPPA	AZ66F-L02_SSR01	DIVANO POPPA	LACCATO BRONZO	5	Damiano

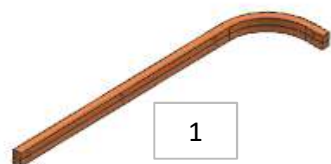

1

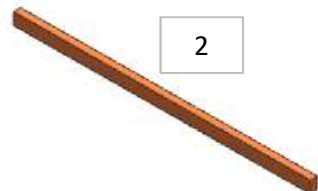

2

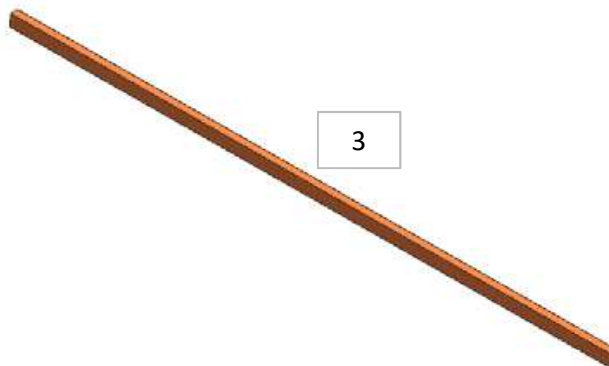

3

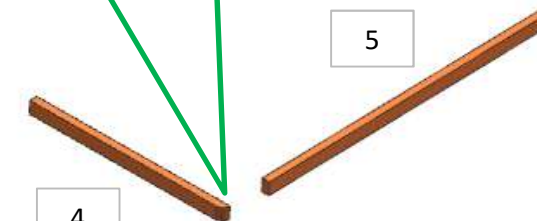

4

5

- 1 - sviluppo 521 x H 24 x sp 12mm
- 2 - L 493 x H 24 x sp 12mm
- 3 - L 998 x H 24 x sp 12mm
- 4 - L 321 x H 24 x sp 12mm
- 5 - L 496 x H 24 x sp 12mm

VERIFICARE PRESENZA
TONDO