

AZ68F

DA MAT. 265 REV. 29-04-2024

LOCALE	CODICE	DESCRIZIONE COMPONENTE	FINITURA	Q.TA	OPERATORE
SALONE	AZ68F-R01_SB01	MURATA BASSA SX POPPA	LASTRA CHIARA	8	Damiano

- 1 - L 422 x H 216 x sp 16 mm
- 2 - L 373 x H 216 x sp 16 mm
- 3 - L 407 x H 855 x sp 32 mm
- 4 - L 424 x H 425 x sp 32 mm
- 5 - L 424 x H 853 x sp 32 mm
- 6 - dia. 32 x H 855 mm
- 7 - dia. 32 x H 853 mm
- 8 - dia.32 x H 425 mm

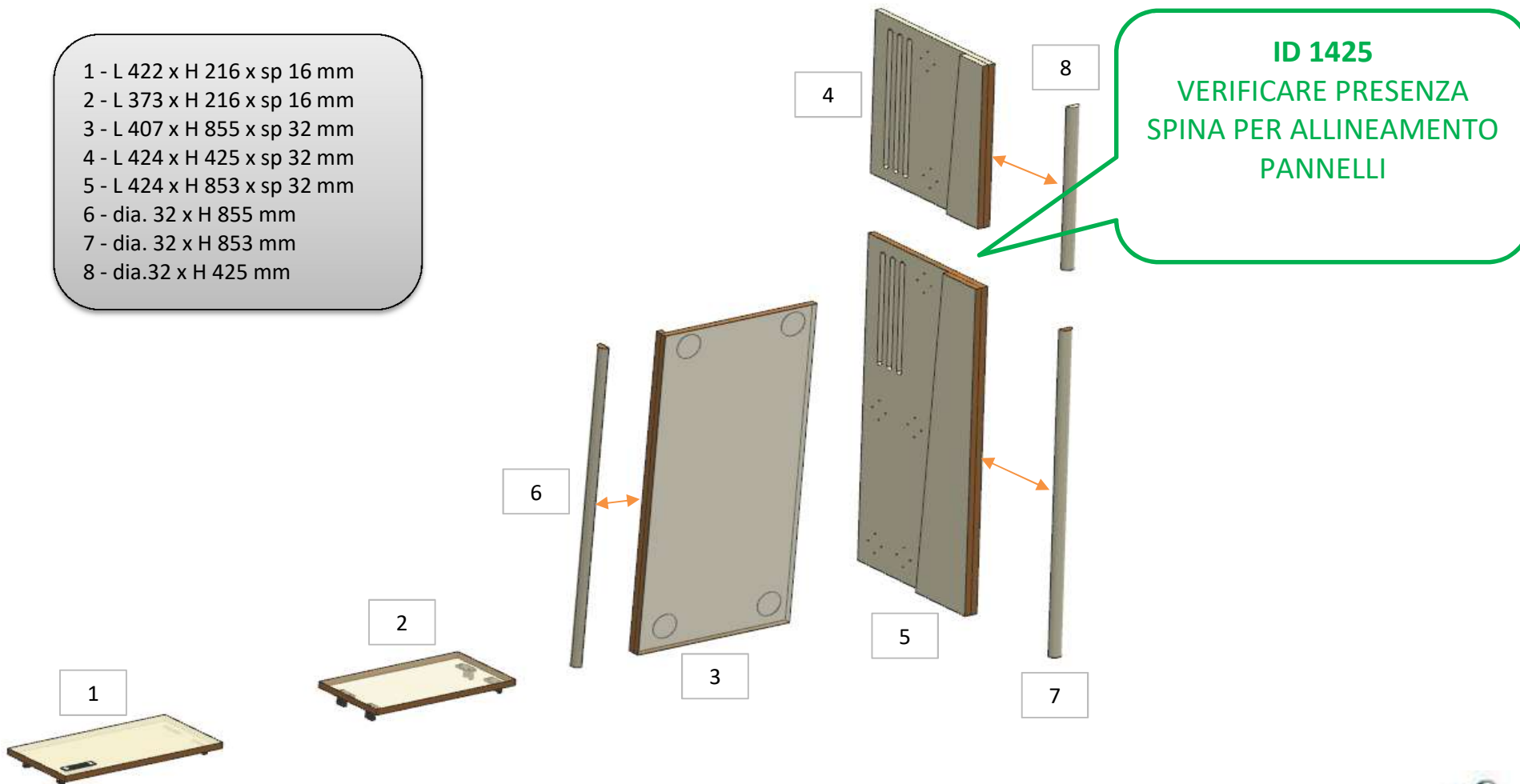

AZ68F

DA MAT. 265 REV. 29-04-2024

LOCALE	CODICE	DESCRIZIONE COMPONENTE	FINITURA	Q.TA	OPERATORE
SALONE	AZ68F-R02_SB01	MURATA BASSA SX POPPA	LASTRA TEAK	3	Damiano

- 1 - L 2540,8 x H 32 x 30 mm
- 2 - L 441 x H 32 x sp 6 mm
- 3 - L 441 x H 32 x sp 6 mm

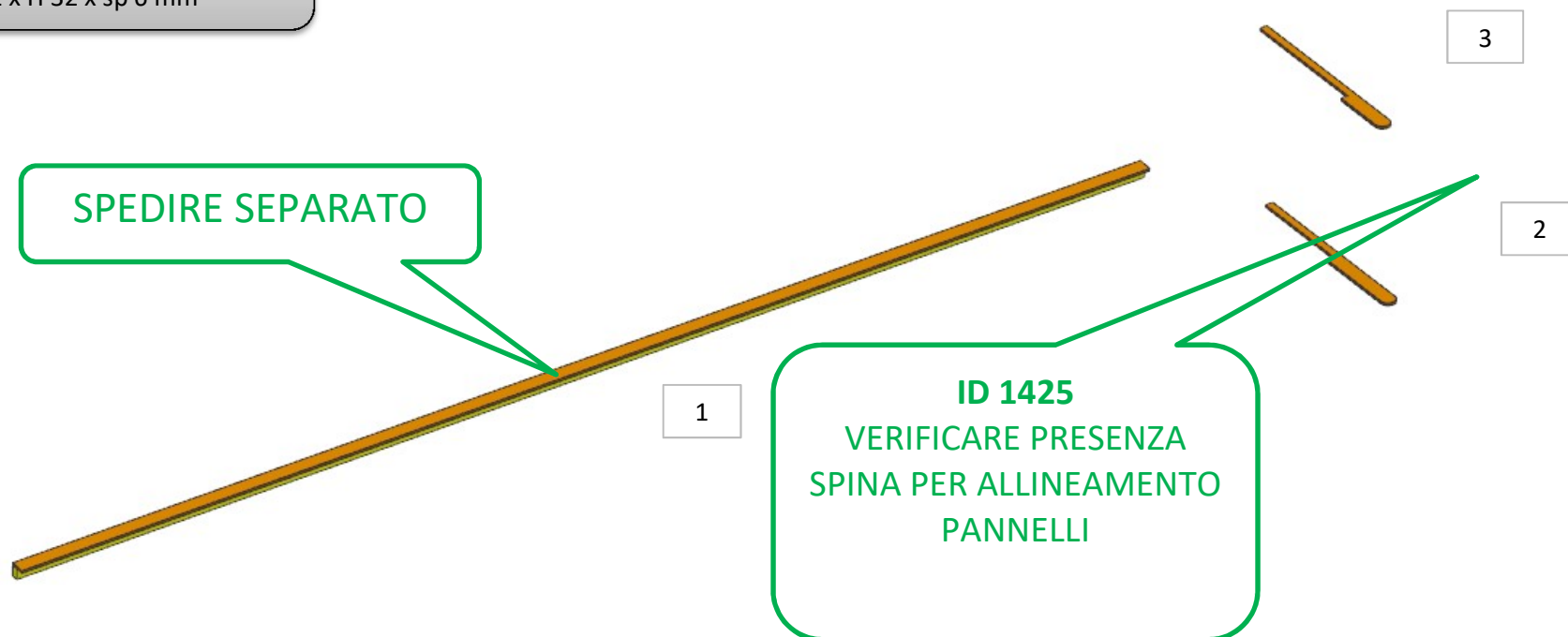

AZ68F

DA MAT. 203 REV. 29-04-2024

LOCALE	CODICE	DESCRIZIONE COMPONENTE	FINITURA	Q.TA	OPERATORE
SALONE	AZ68F-L01_SB01	MURATA BASSA SX POPPA	LACCATO NERO OPACO	4	Damiano

* faccia dove viene applicata la finitura
 ↓ filo dove viene applicata la finitura

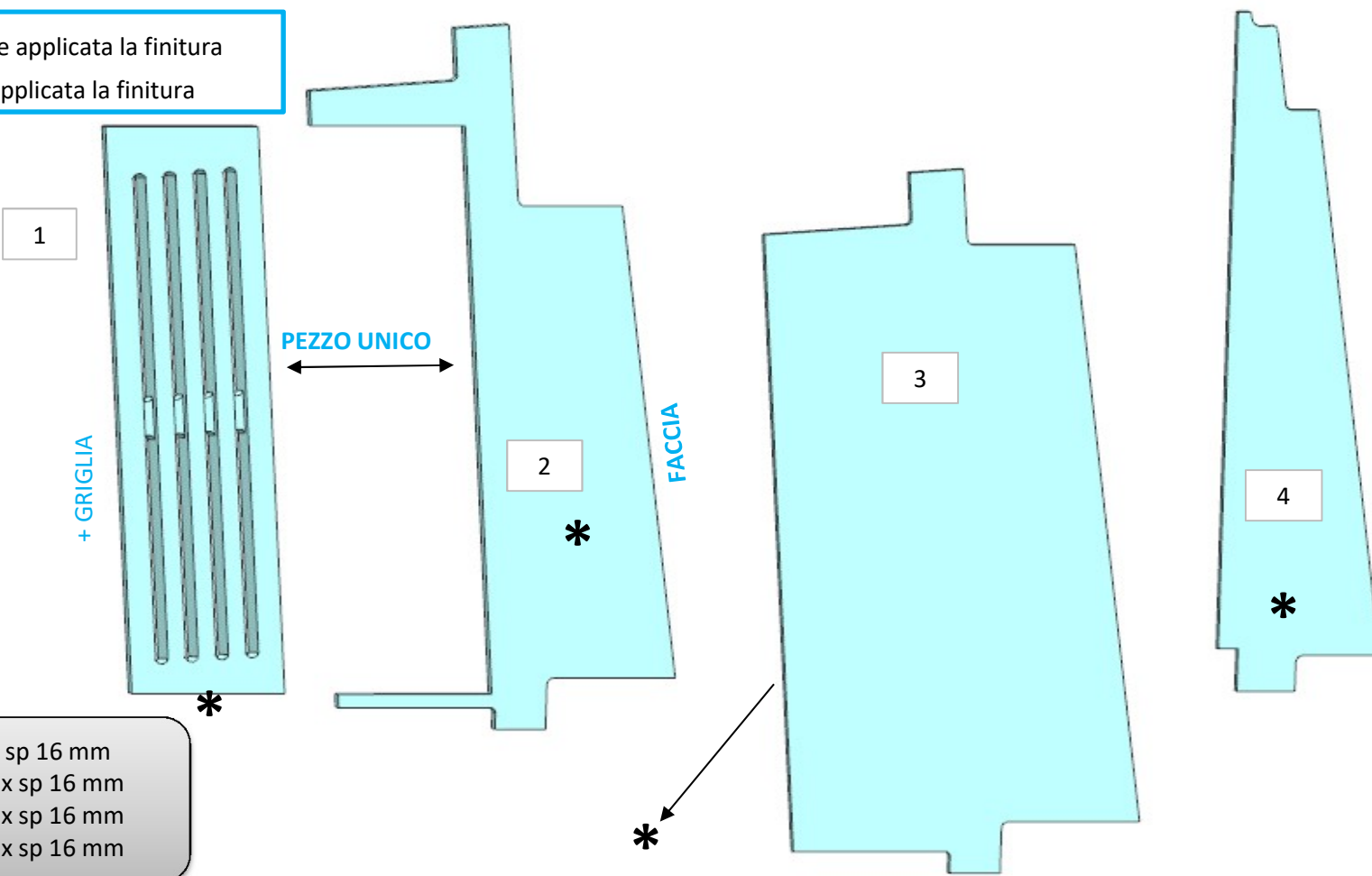

- 1 - L 215 x H 855 x sp 16 mm
- 2 - L 260 x H 1058 x sp 16 mm
- 3 - L 487 x H 1058 x sp 16 mm
- 4 - L 228 x H 1022 x sp 16 mm

AZ68F

DA MAT. 203 REV. 25-05-2021

LOCALE	CODICE	DESCRIZIONE COMPONENTE	FINITURA	Q.TA	OPERATORE
SALONE	AZ68F-A01_SB01	MURATA BASSA SX POPPA	RIMEX NERO	4	Damiano

- 1 - L 215 x H 853 x sp 1
- 2 - L 275 x H 152 x sp 1
- 3 - L 215 x H 248 x sp 1
- 4 - L 283 x H 533 x sp 1

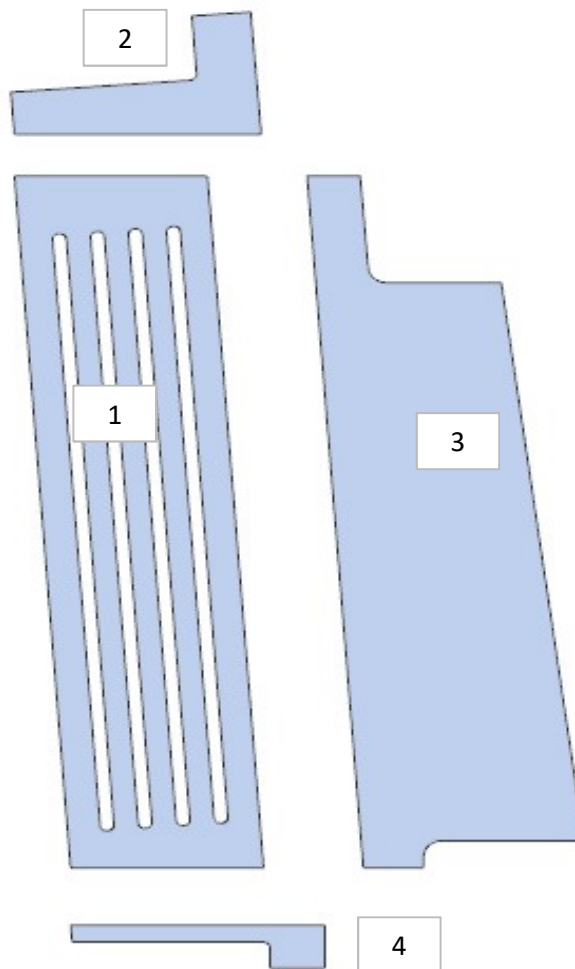

AZ68F

DA MAT. 265 Rev. 29-04-2024

LOCALE	CODICE	DESCRIZIONE COMPONENTE	FINITURA	Q.TA	OPERATORE
SALONE	AZ68F-MF_SD01	PLENUM AC MURATA SX			Damiano

FERRAMENTA:

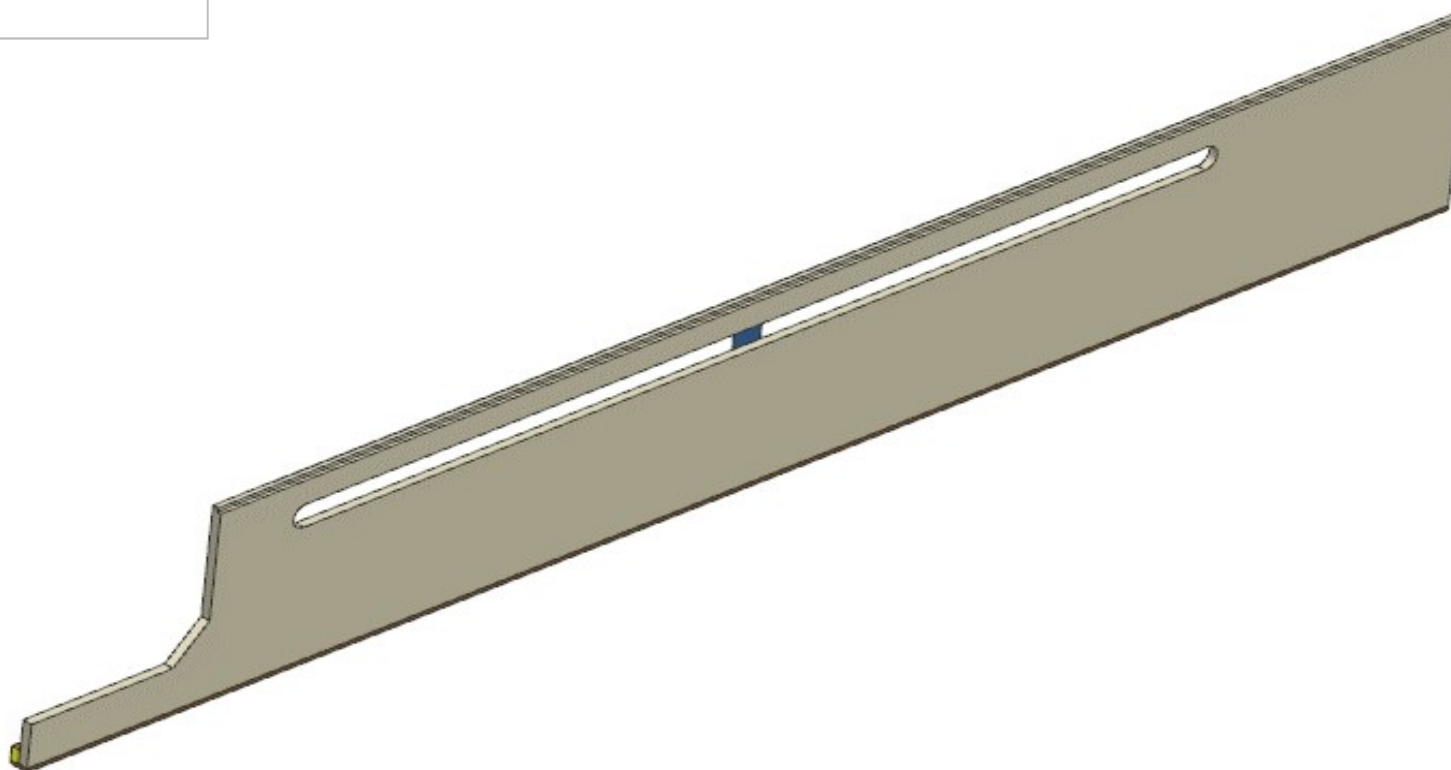

AZ68F

DA MAT. 265 REV. 29-04-2024

LOCALE	CODICE	DESCRIZIONE COMPONENTE	FINITURA	Q.TA	OPERATORE
SALONE	AZ68F-R01_SD01	PLENUM AC MURATA SX	LASTRA CHIARA	3	Damiano

- 1 - L 2558 x H 330 x sp 32 mm
- 2 - L 2126 x H 219 x sp 16 mm
- 3 - L 2126 x H 78 x sp 16 mm

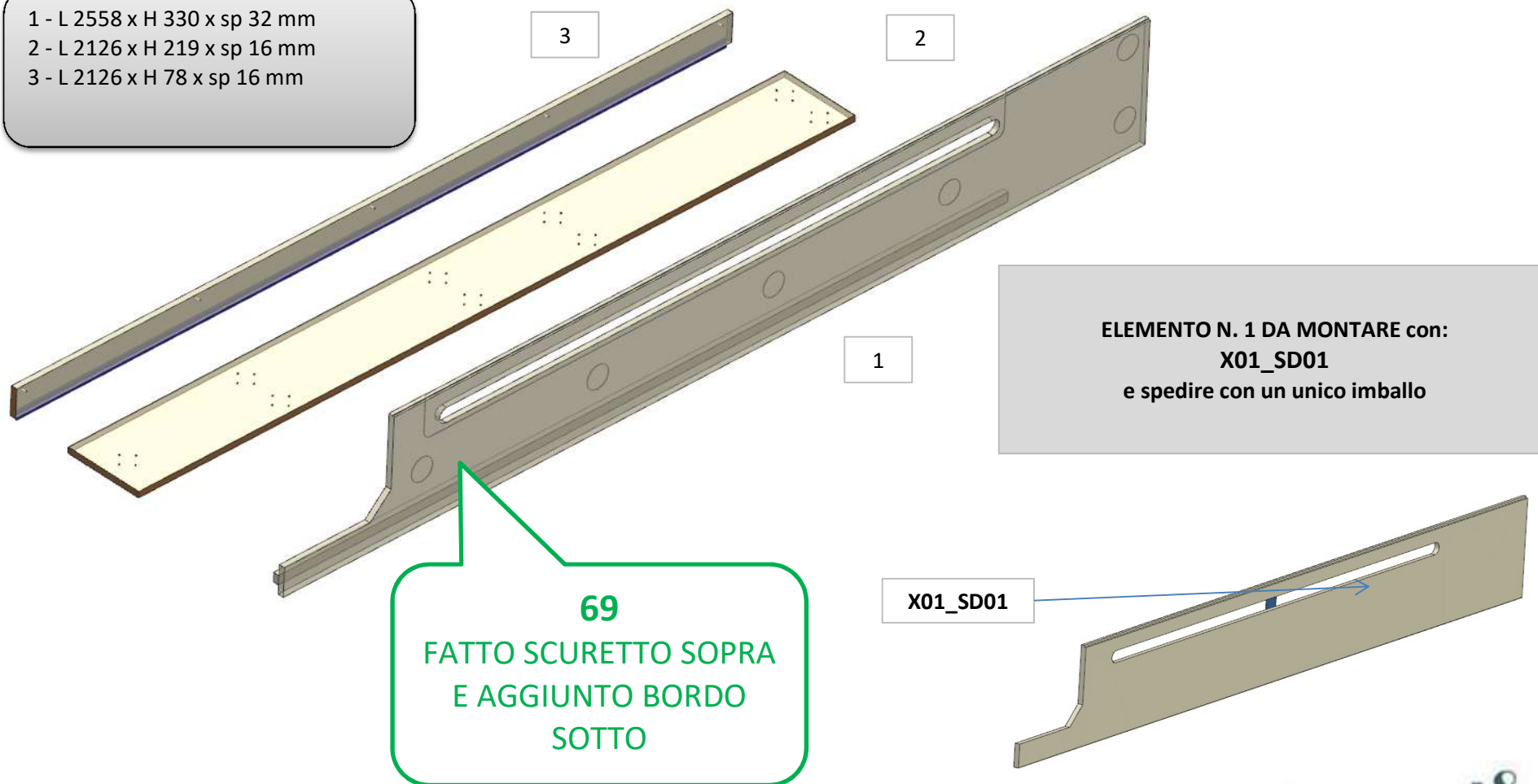

AZ68F

REV.265 REV. 29-04-2024

LOCALE	CODICE	DESCRIZIONE COMPONENTE	FINITURA	Q.TA	OPERATORE
SALONE	AZ68F-R02_SD01	PLENUM AC MURATA SX	LASTRA TEAK	1	Damiano

1 - L 2558 x 32 x H 30 mm

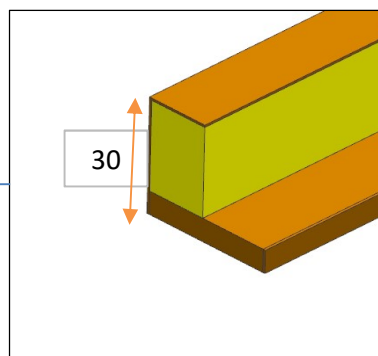
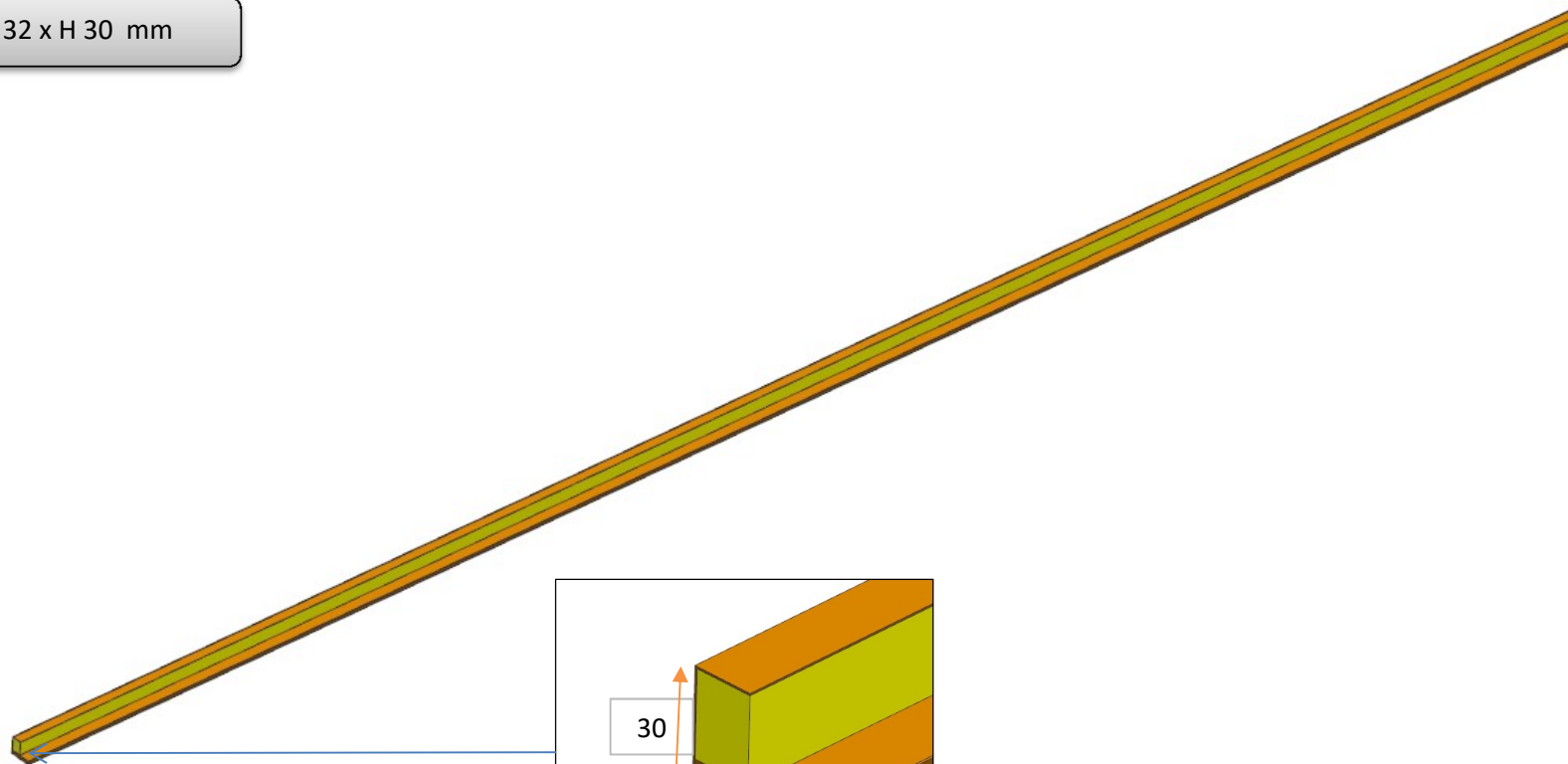

AZ68F

REV. 29-04-2024

LOCALE	CODICE	DESCRIZIONE COMPONENTE	FINITURA	Q.TA	OPERATORE
SALONE	AZ68F-X01_SD01	PLENUM AC MURATA SX	LAMINATO NERO	1	Damiano

1 - L 1722 x H 119.5 x sp 1 mm

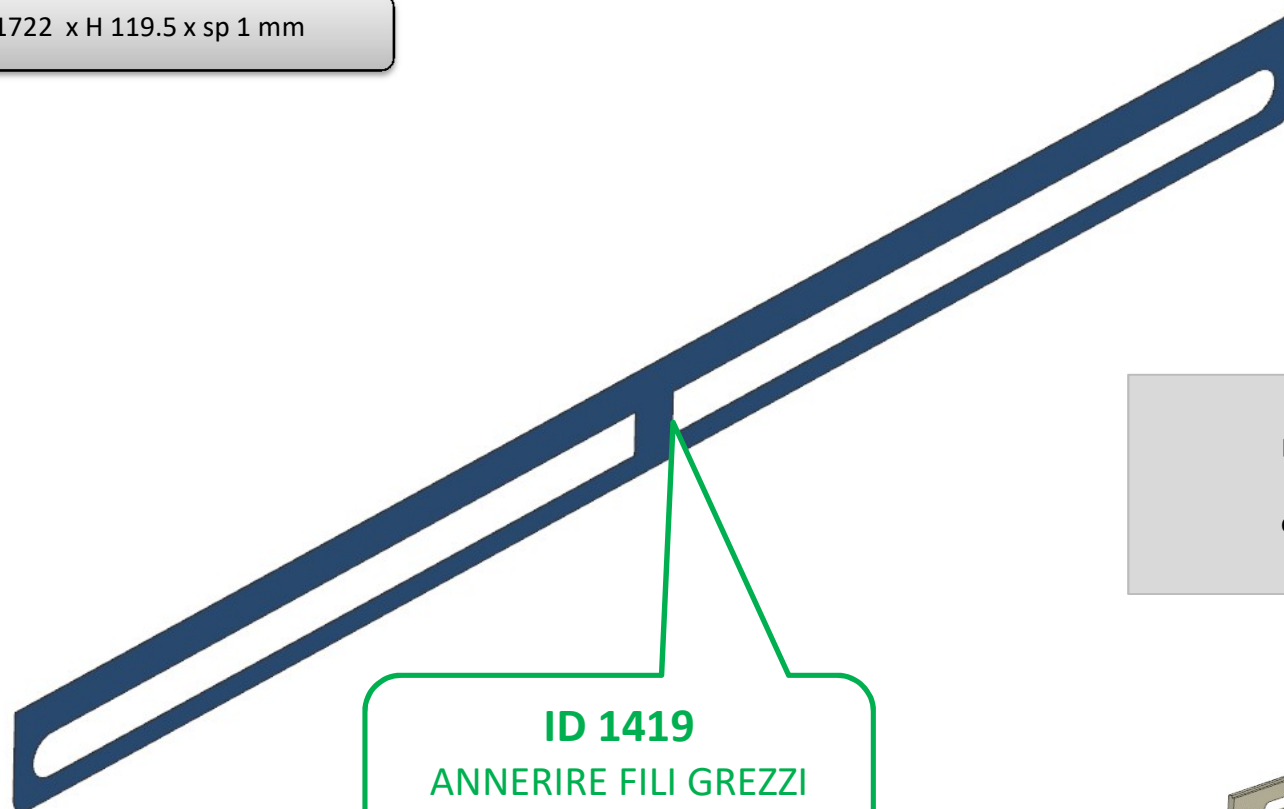

ID 1419
ANNERIRE FILI GREZZI
A VISTA LAMINATO

ELEMENTO DA MONTARE con:
R01_SD01_01
e spedire con un unico imballo

R01_SD01

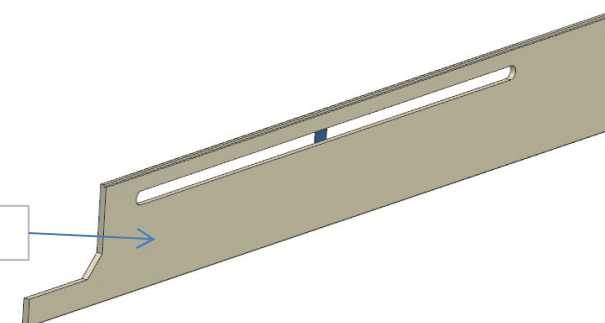

consonni&c

AZ68F

DA MAT. 265 REV. 29-04-2024

LOCALE	CODICE	DESCRIZIONE COMPONENTE	FINITURA	Q.TA	OPERATORE
SALONE	AZ68F-R01_SE01	MURATA BASSA SX PRUA	LASTRA CHIARA	3	Damiano

- 1 - L 1731 x H 117.5 x sp 16 mm
- 2 - L 828 x H 117.5 x sp 16 mm
- 3 - SVILUPPO 899 x H 180 x sp 16 mm

ID 1802
PRODURRE INSIEME E FARE MOLTA
ATTENZIONE ALL'ALLINEAMENTO DELLO
SPESSORE

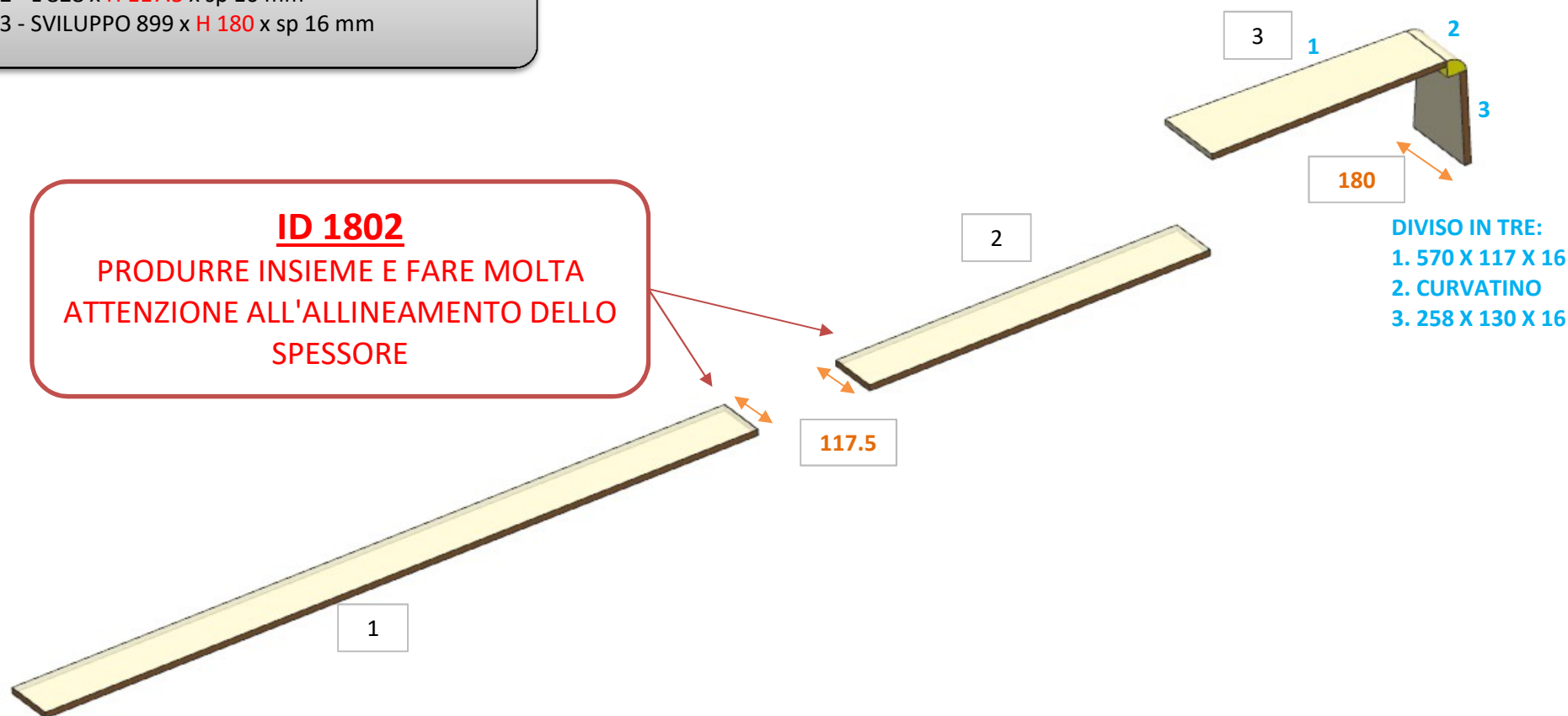

AZ68F

DA MAT. 265 REV. 29-04-2024

LOCALE	CODICE	DESCRIZIONE COMPONENTE	FINITURA	Q.TA	OPERATORE
SALONE	AZ68F-R02_SE01	MURATA BASSA SX PRUA	LASTRA TEAK	2	Damiano

- 1 - L 1732 x H 42 x sp 20 mm
- 2 - SVILUP. 936 x H 42 x sp mm
- 3 - SVILUP. 1217 x H 42 x sp 20 mm



ID 1802
PRODURRE INSIEME E FARE MOLTA
ATTENZIONE ALL'ALLINEAMENTO DELLO
SPESSORE

AZ68F

DA MAT. 265 REV. 29-04-2024

LOCALE	CODICE	DESCRIZIONE COMPONENTE	FINITURA	Q.TA	OPERATORE
SALONE	AZ68F-X01_SE01	MURATA BASSA SX PRUA	LAMINATO NERO	2	Damiano

1 - L 1732 x H 44 x sp 2 mm
2 - L 1726.5 x H 307 x sp 2 mm

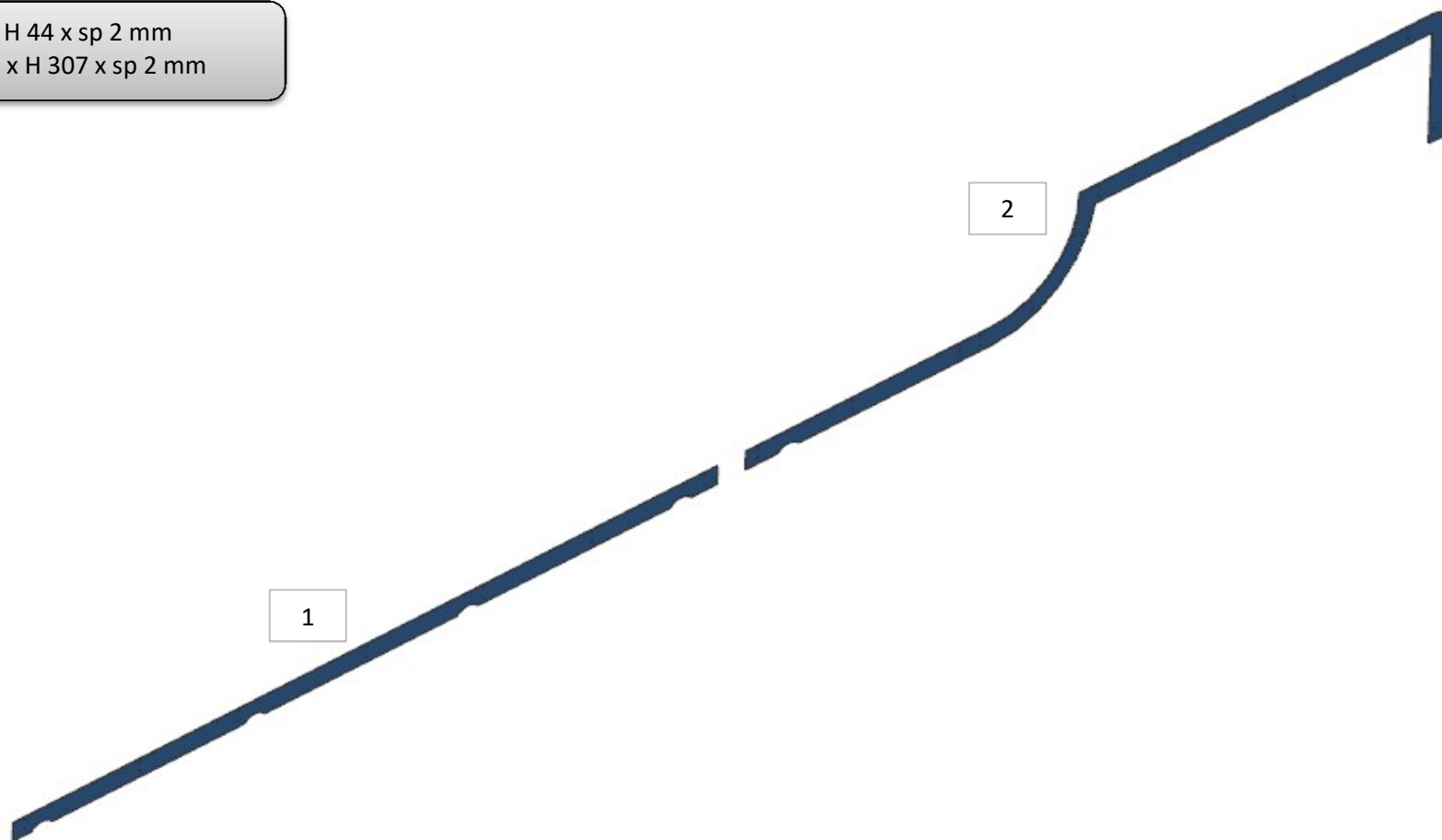

AZ68F

DA MAT. 203 REV. 29-04-2024

LOCALE	CODICE	DESCRIZIONE COMPONENTE	FINITURA	Q.TA	OPERATORE
SALONE	AZ68F-L01_SE01	MURATA BASSA SX PRUA	LACCATO NERO OPACO	2	Damiano

1 - L 1005 x H 200 x sp 10
2 - L 749 x H 167 x sp 10

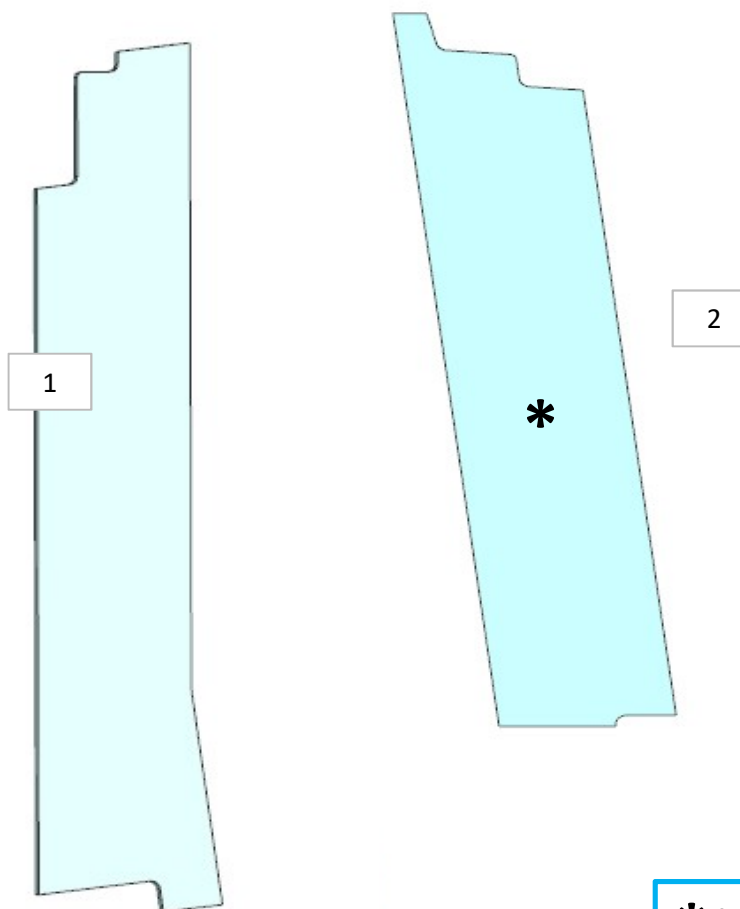

* faccia dove viene applicata la finitura

↓ filo dove

consonni&c

AZ68F

DA MAT. 203 REV. 25-05-2021

LOCALE	CODICE	DESCRIZIONE COMPONENTE	FINITURA	Q.TA	OPERATORE
SALONE	AZ68F-A01_SE01	MURATA BASSA SX PRUA	ACCIAIO	1	Damiano

1 - L 757 x H 320 x sp 2.5 mm

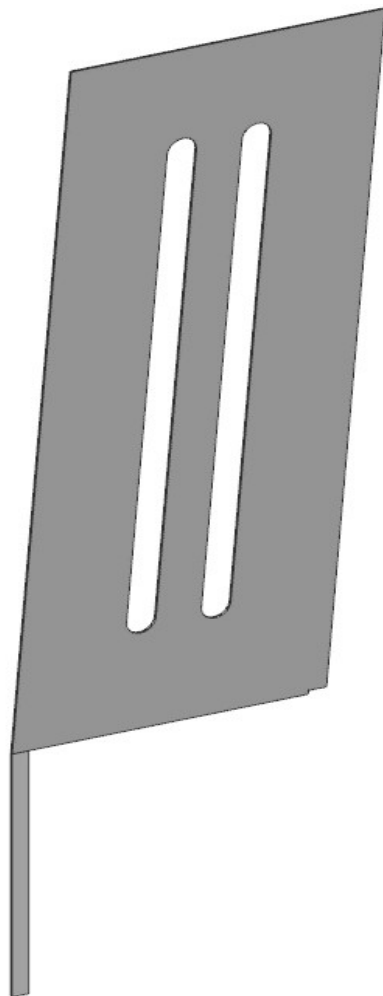

AZ68F

DA MAT. 265 REV. 29-04-2024

LOCALE	CODICE	DESCRIZIONE COMPONENTE	FINITURA	Q.TA	OPERATORE
SALONE	AZ68F-L01_SF01	MANTOVANA SX PRUA	LACCATO BIANCO ARTICO	2	Damiano

1 - L 2538.5 x H 180.5 x 42 mm
2 - L 2537 x H 80 x 36 mm

da mat.207
MODIFICATA SEZIONE PARTE
TONDA

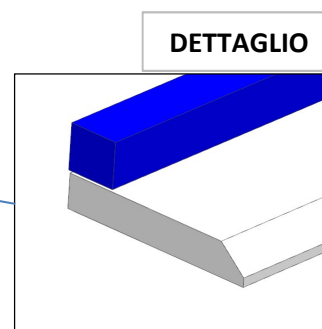
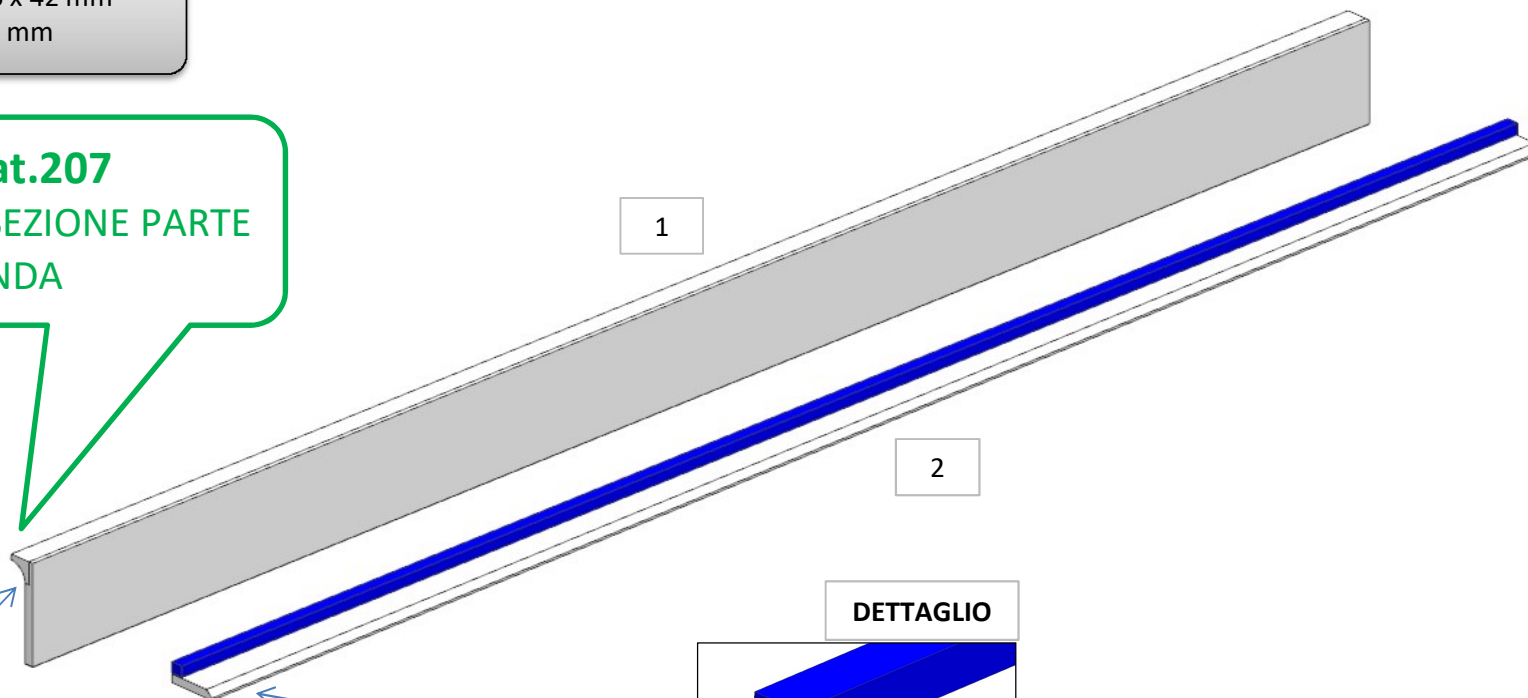
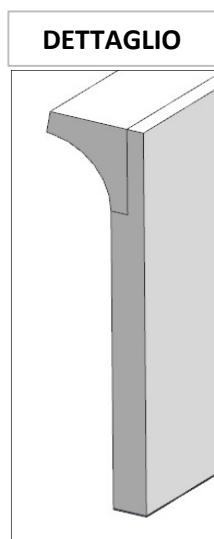

AZ68F

DA MAT.201

REV. 20-04-2021

LOCALE	CODICE	DESCRIZIONE COMPONENTE	FINITURA	Q.TA	OPERATORE
SALONE	AZ68F-MG_SH01	COLONNA POPPA MURATA DX			Damiano

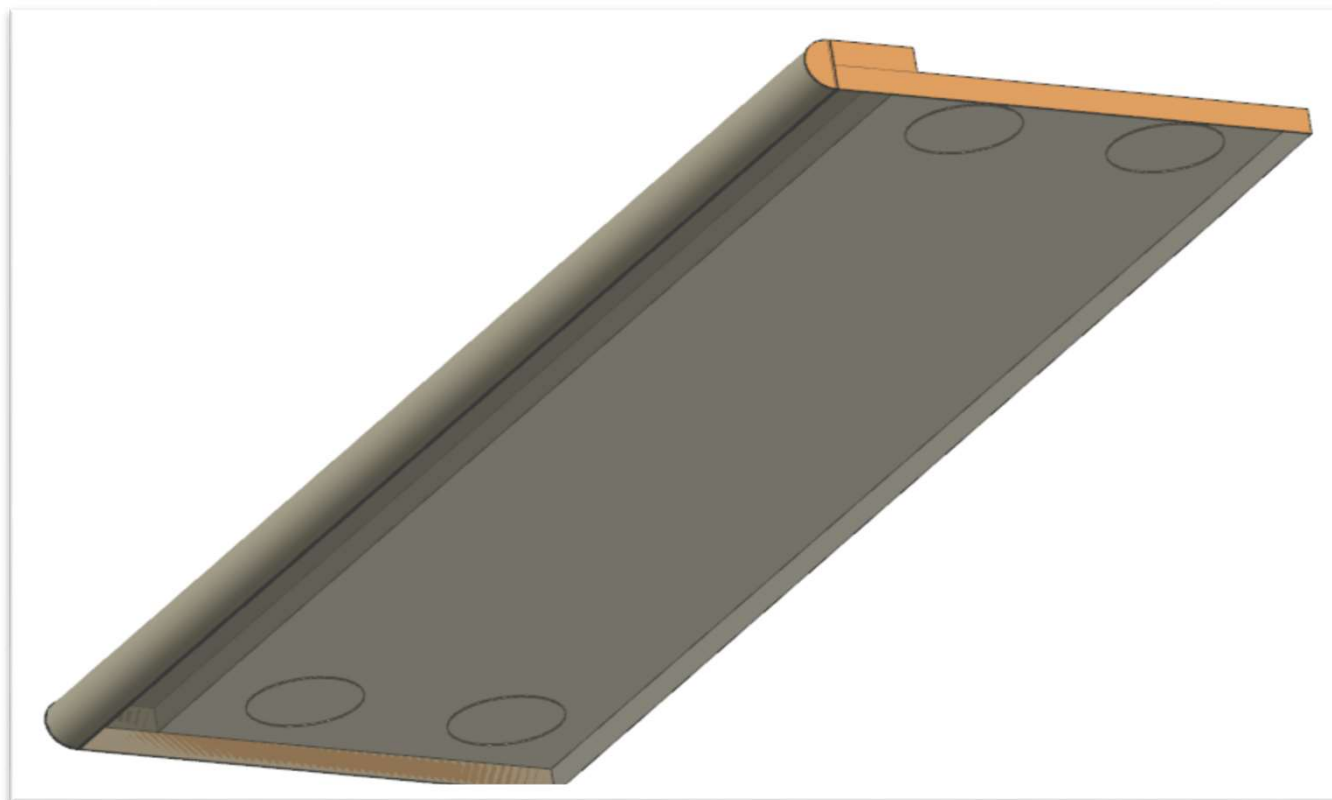

AZ68F

DA MAT.201 REV. 29-04-2024

LOCALE	CODICE	DESCRIZIONE COMPONENTE	FINITURA	Q.TA	OPERATORE
SALONE	AZ68F-R01_SH01	COLONNA POPPA MURATA DX	LASTRA CHIARA	3	Damiano

- 1 - L 285 x H 874 x sp 32 mm
- 2 - L 119.5 x H 2025 x 141 mm
- 3 - dia. 32 x H 874

CURVATINO
SEPARATO
874 X 32 X 16

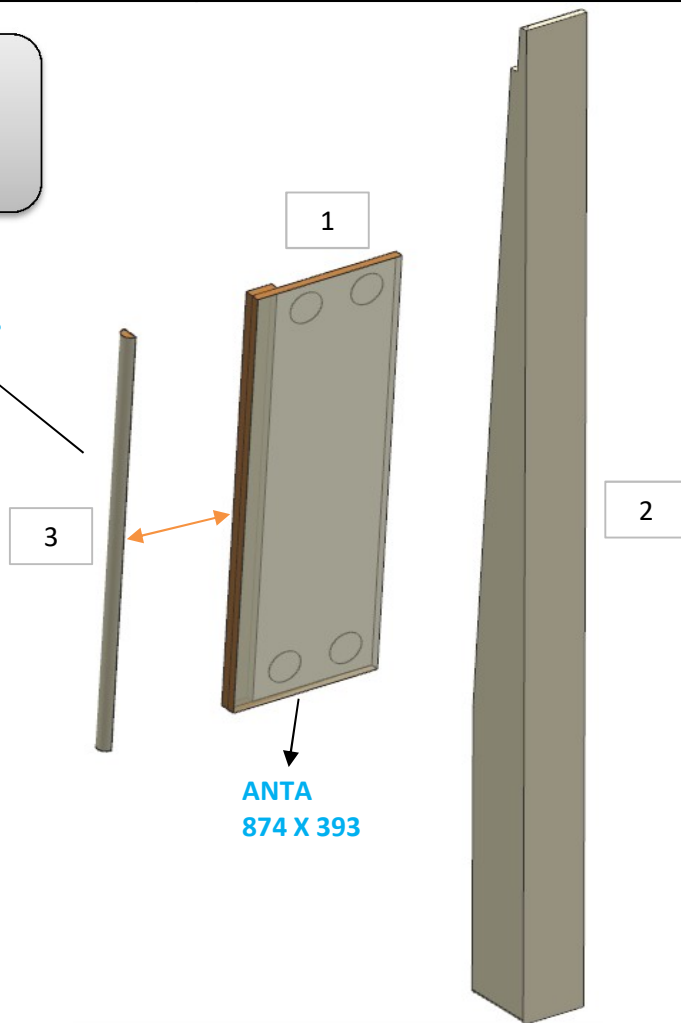

ELEMENTO N.1-3 DA MONTARE:
MG_SH01
e spedire con un unico imballo

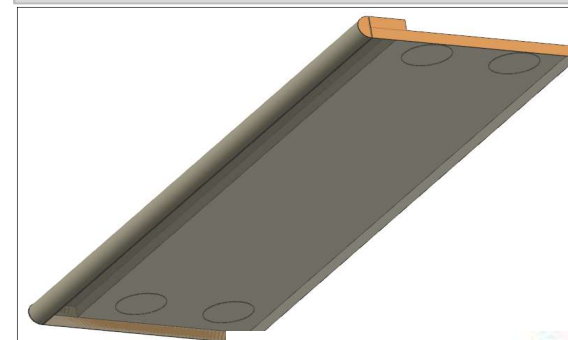

consonni&c

AZ68F

DA MAT. 203 REV. 29-04-2024

LOCALE	CODICE	DESCRIZIONE COMPONENTE	FINITURA	Q.TA	OPERATORE
SALONE	AZ68F-L01_SH01	COLONNA POPPA MURATA DX	LACCATO NERO OPACO	1	Damiano

1 - L 267 x H 987 x sp 10

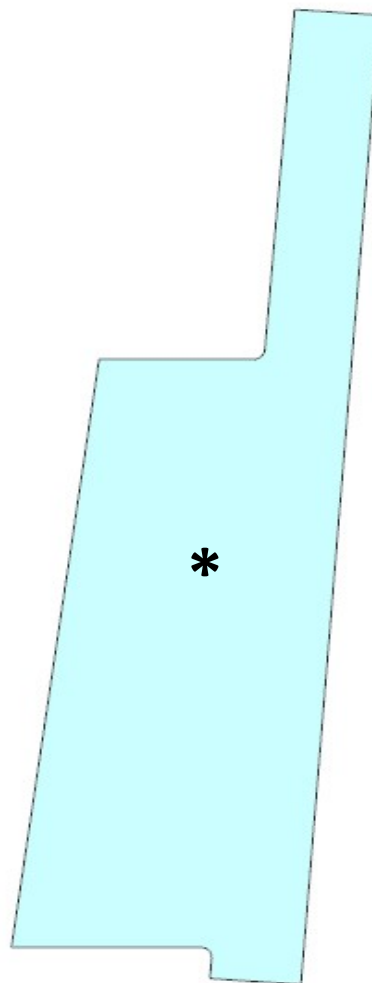

* faccia dove viene applicata la finitura
↓ filo dove viene applicata la finitura

AZ68F

REV. 29-04-2024

LOCALE	CODICE	DESCRIZIONE COMPONENTE	FINITURA	Q.TA	OPERATORE
SALONE	AZ68F-R01_SI01	STRUTTURA MURATA BASSA DX	LASTRA CHIARA	1	Damiano

1 - L 2430 x H 84 x sp 15 mm

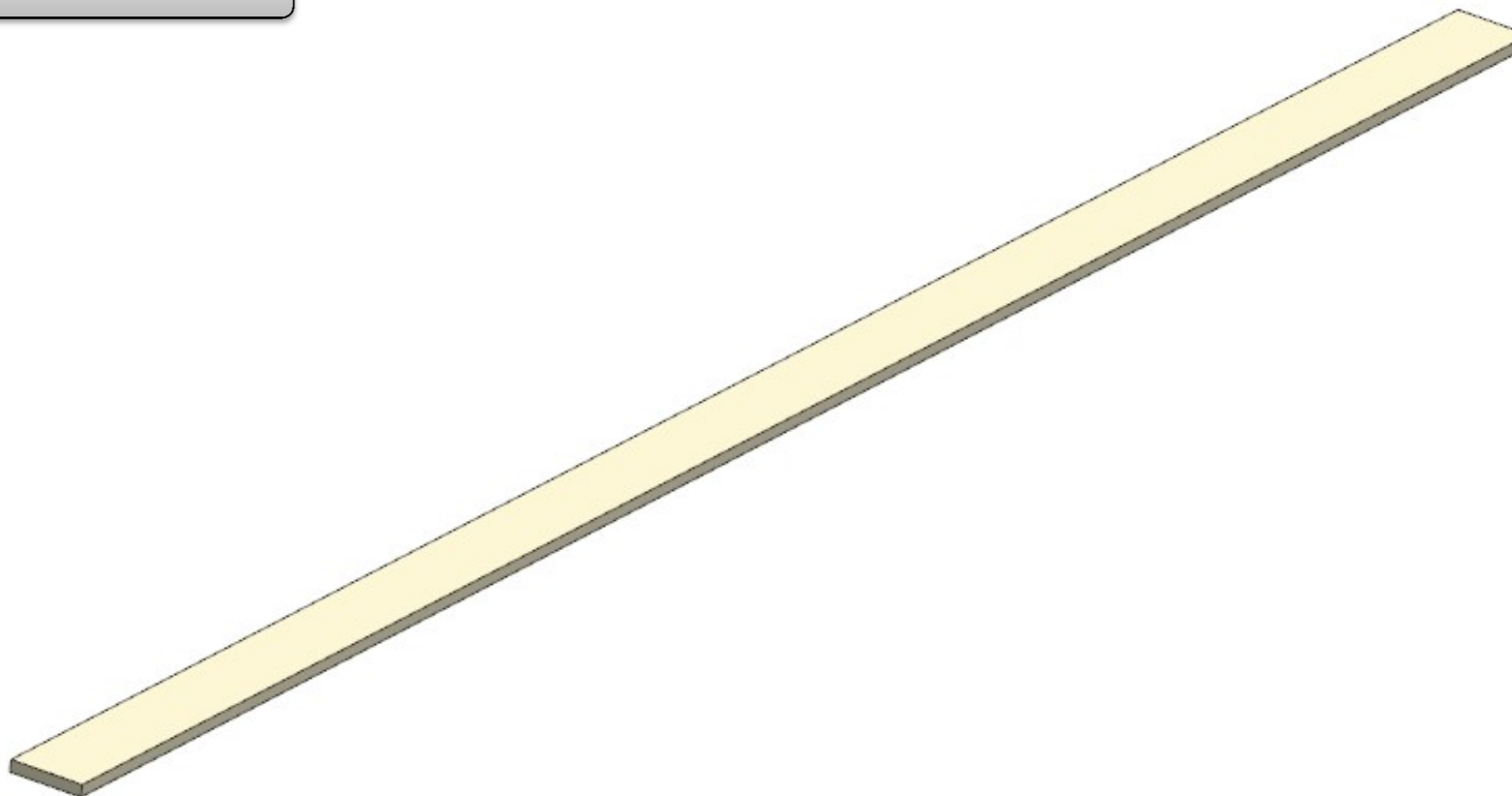

AZ68F

REV.2024 REV. 29-04-2024

LOCALE	CODICE	DESCRIZIONE COMPONENTE	FINITURA	Q.TA	OPERATORE
SALONE	AZ68F-R02_SI01	STRUTTURA MURATA BASSA DX	LASTRA TEAK	1	Damiano

1 - L 3007.5 x 32 x H. 30 mm

87

CAMBIATO FINITURA -
PRIMA MOGANO 100
GLOSS

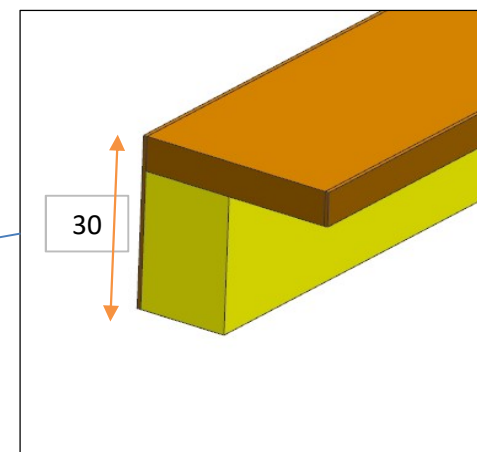
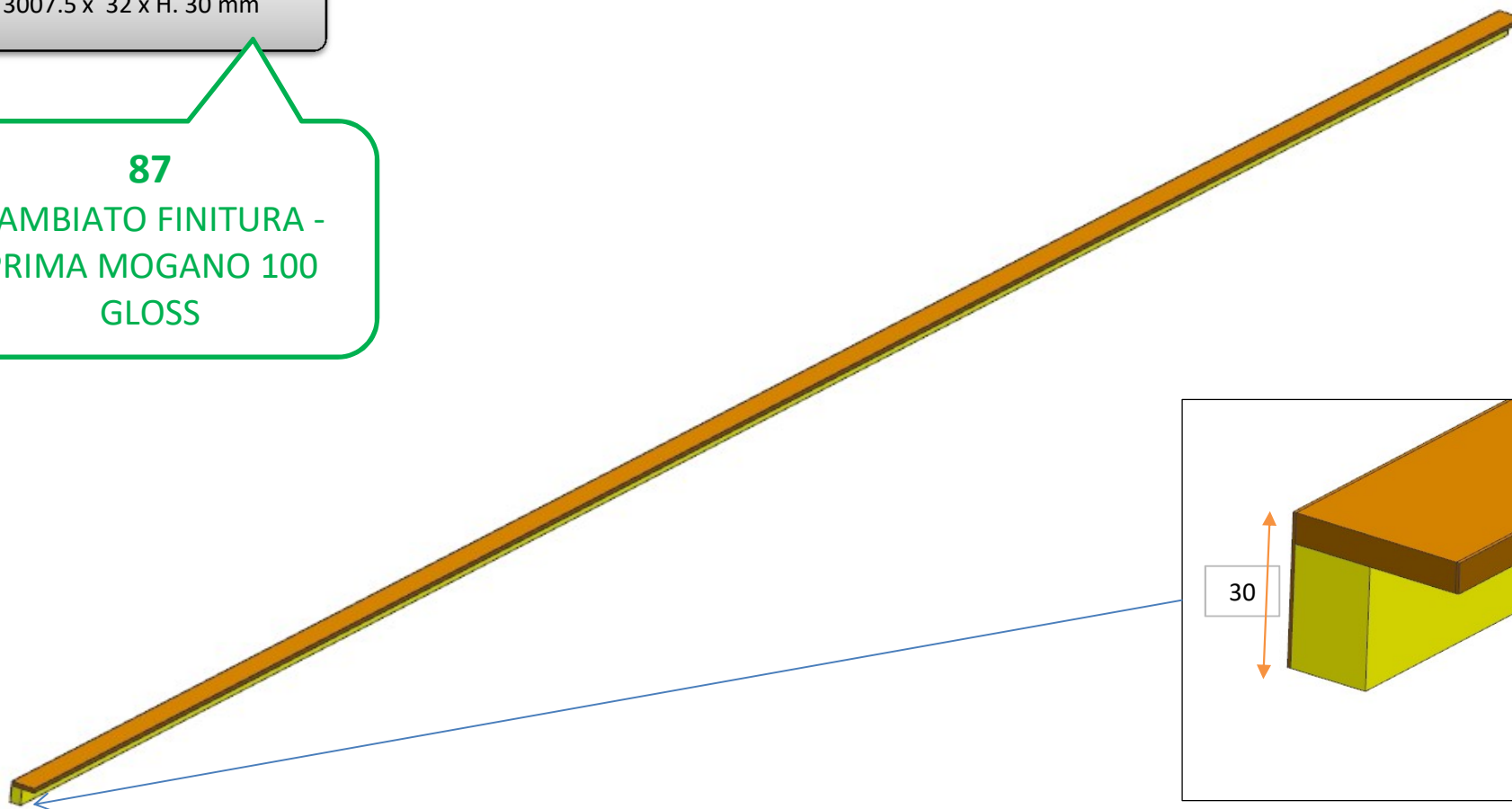

consonni&c

AZ68F

Rev. 29-04-2024

LOCALE	CODICE	DESCRIZIONE COMPONENTE	FINITURA	Q.TA	OPERATORE
SALONE	AZ68F-MF_SL01	COLONNA PLENUM DX PRUA			Damiano

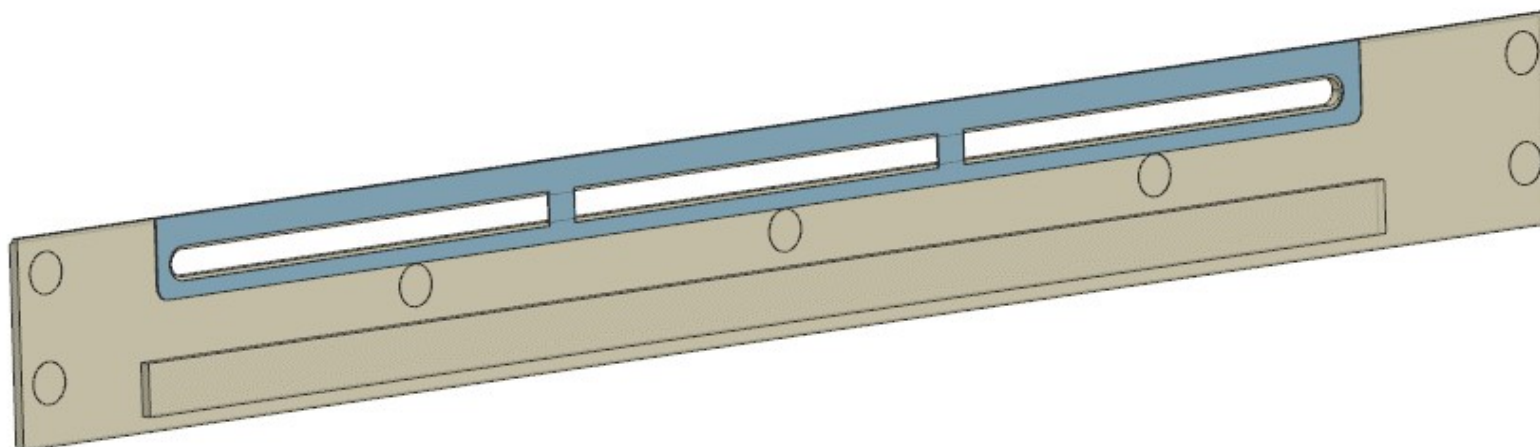

AZ68F

DA MAT. 265 REV. 29-04-2024

LOCALE	CODICE	DESCRIZIONE COMPONENTE	FINITURA	Q.TA	OPERATORE
SALONE	AZ68F-R01_SL01	COLONNA PLENUM DX PRUA	LASTRA CHIARA	3	Damiano

- 1 - L 3007.5 x H 310.5 x sp 16 mm
- 2 - L 391 x H 874 x sp 32 mm
- 3 - dia. 32 x H 874 mm

1

ELEMENTO N.2-3 DA MONTARE:
MG_SL01
e spedire con un unico imballo

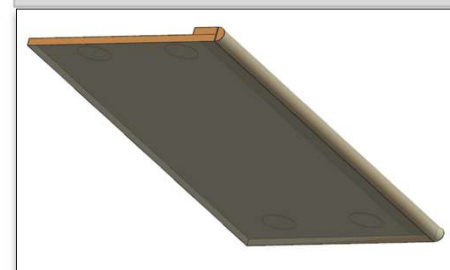

69

FATTO SCURETTO SOPRA
E AGGIUNTO BORDO
SOTTO

3

2

ELEMENTO N.1 DA MONTARE con:
X01_SL01
e spedire con un unico imballo

X01_SL01

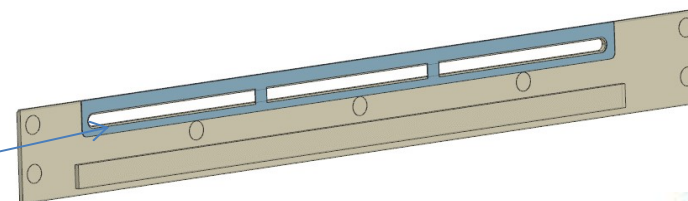

consonni&c

AZ68F

DA MAT.265 REV. 29-04-2024

LOCALE	CODICE	DESCRIZIONE COMPONENTE	FINITURA	Q.TA	OPERATORE
SALONE	AZ68F-R02_SL01	COLONNA PLENUM DX PRUA	LASTRA TEAK	1	Damiano

1 - L 3007.5 x 32 x H 31 mm

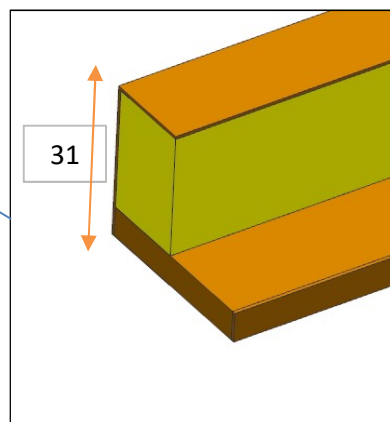
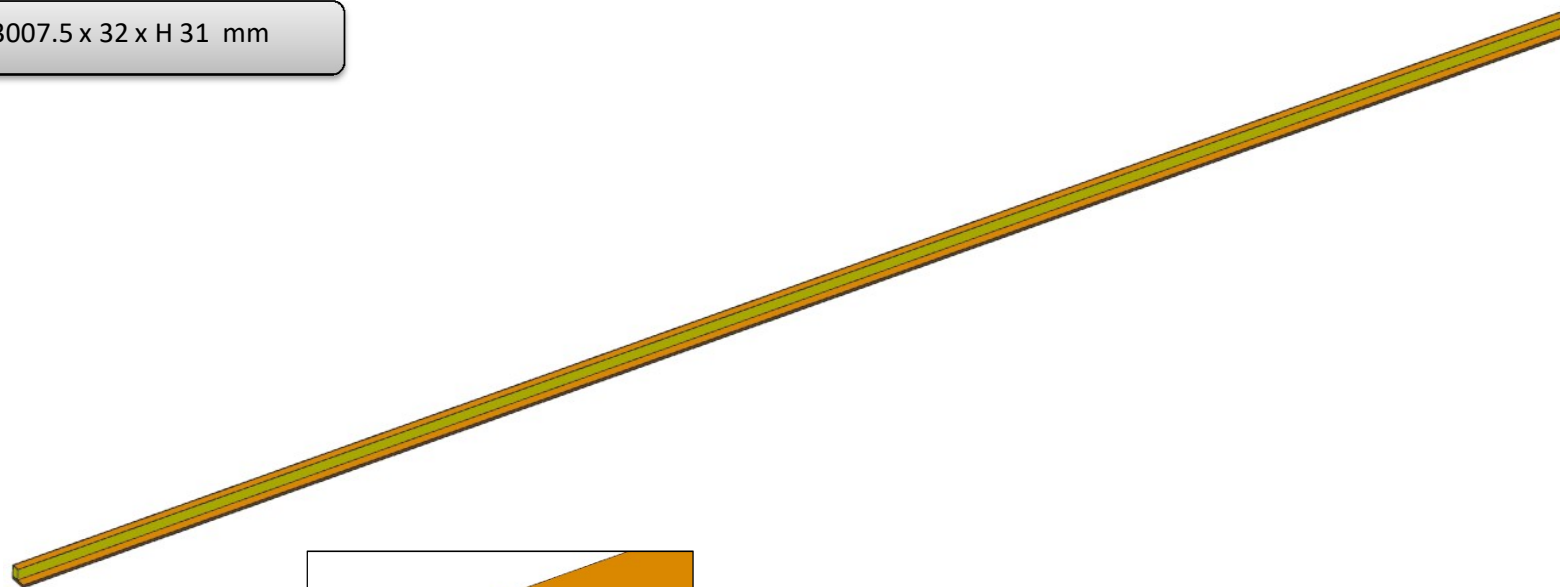

AZ68F

REV. 29-04-2024

LOCALE	CODICE	DESCRIZIONE COMPONENTE	FINITURA	Q.TA	OPERATORE
SALONE	AZ68F-X01_SL01	COLONNA PLENUM DX PRUA	LAMINATO NERO	1	Damiano

1 - L 2367.5 x H 120.5 x sp 3 mm

ID 1419
ANNERIRE FILI GREZZI
A VISTA LAMINATO

ELEMENTO DA MONTARE con:
R01_SL01
e spedire con un unico imballo

R01_SL01

consonni&c

AZ68F

DA MAT.201

REV. 20-04-2021

LOCALE	CODICE	DESCRIZIONE COMPONENTE	FINITURA	Q.TA	OPERATORE
SALONE	AZ68F-MG_SL01	COLONNA PLENUM DX PRUA			Damiano

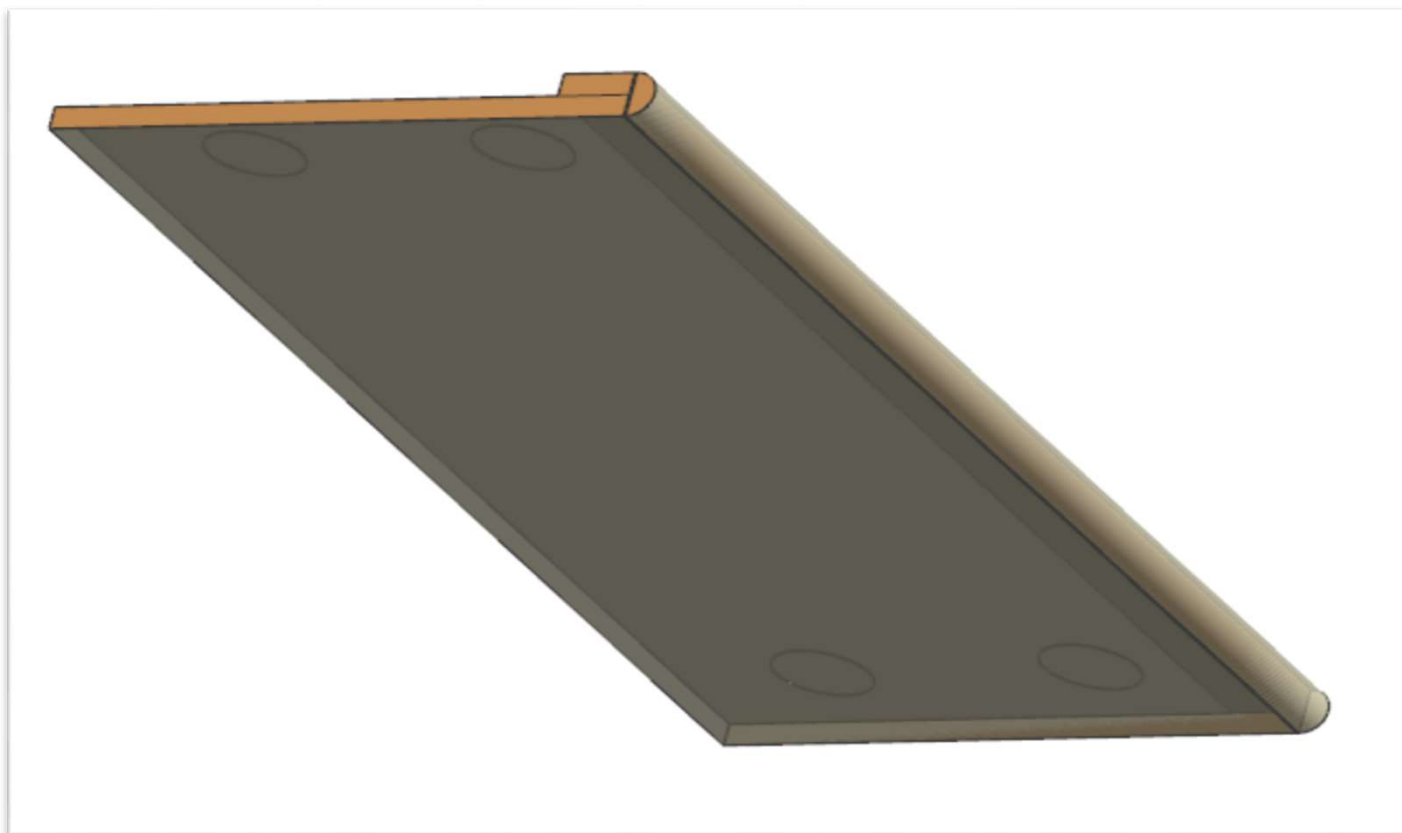

AZ68F

DA MAT. 203 REV. 29-04-2024

LOCALE	CODICE	DESCRIZIONE COMPONENTE	FINITURA	Q.TA	OPERATORE
SALONE	AZ68F-L01_SL01	COLONNA PLENUM DX PRUA	LACCATO NERO OPACO	1	Damiano

1 - L 282 x H 987 x sp 10

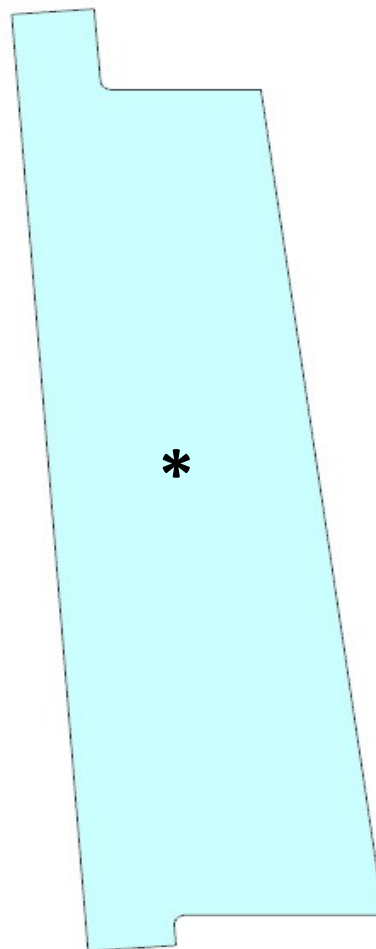

* faccia dove viene applicata la finitura
↓ filo dove viene applicata la finitura

AZ68F

DA MAT. 265 Rev. 29-04-2024

LOCALE	CODICE	DESCRIZIONE COMPONENTE	FINITURA	Q.TA	OPERATORE
SALONE	AZ68F-MF_SM01	GRADINO ALTO			Damiano

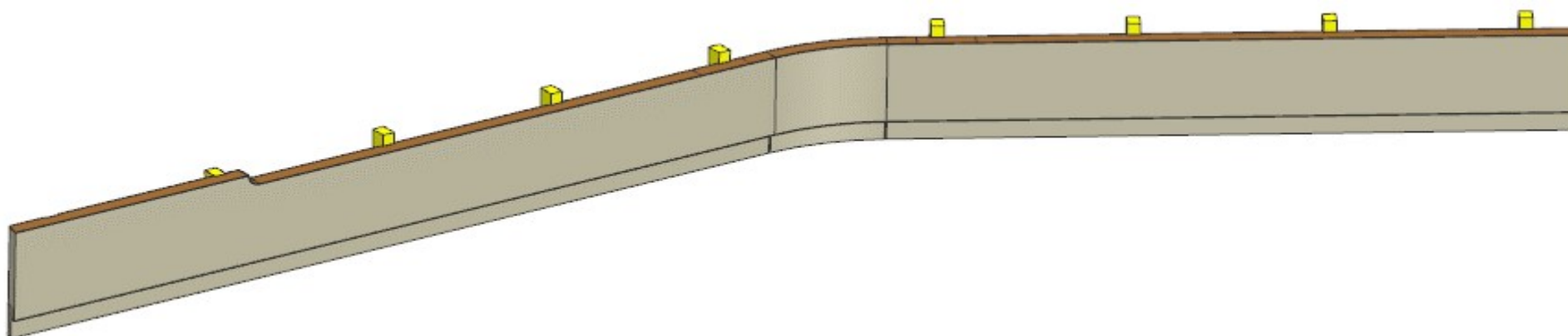

AZ68F

DA MAT. 265 REV. 29-04-2024

LOCALE	CODICE	DESCRIZIONE COMPONENTE	FINITURA	Q.TA	OPERATORE
SALONE	AZ68F-R01_SM01	GRADINO ALTO	LASTRA CHIARA	4	Damiano

- 1 - SVILUPPO 1938 x H 122 x 16 mm
- 2 - L 1027 x H 44 x sp 10 mm
- 3 - SVILUPPO 138 x H 44 x sp 10 mm
- 4 - L 775 x H 44 x sp 10 mm

CURVATO UNICO
CONTROLLARE CREPE PEZZO
CENTRALE

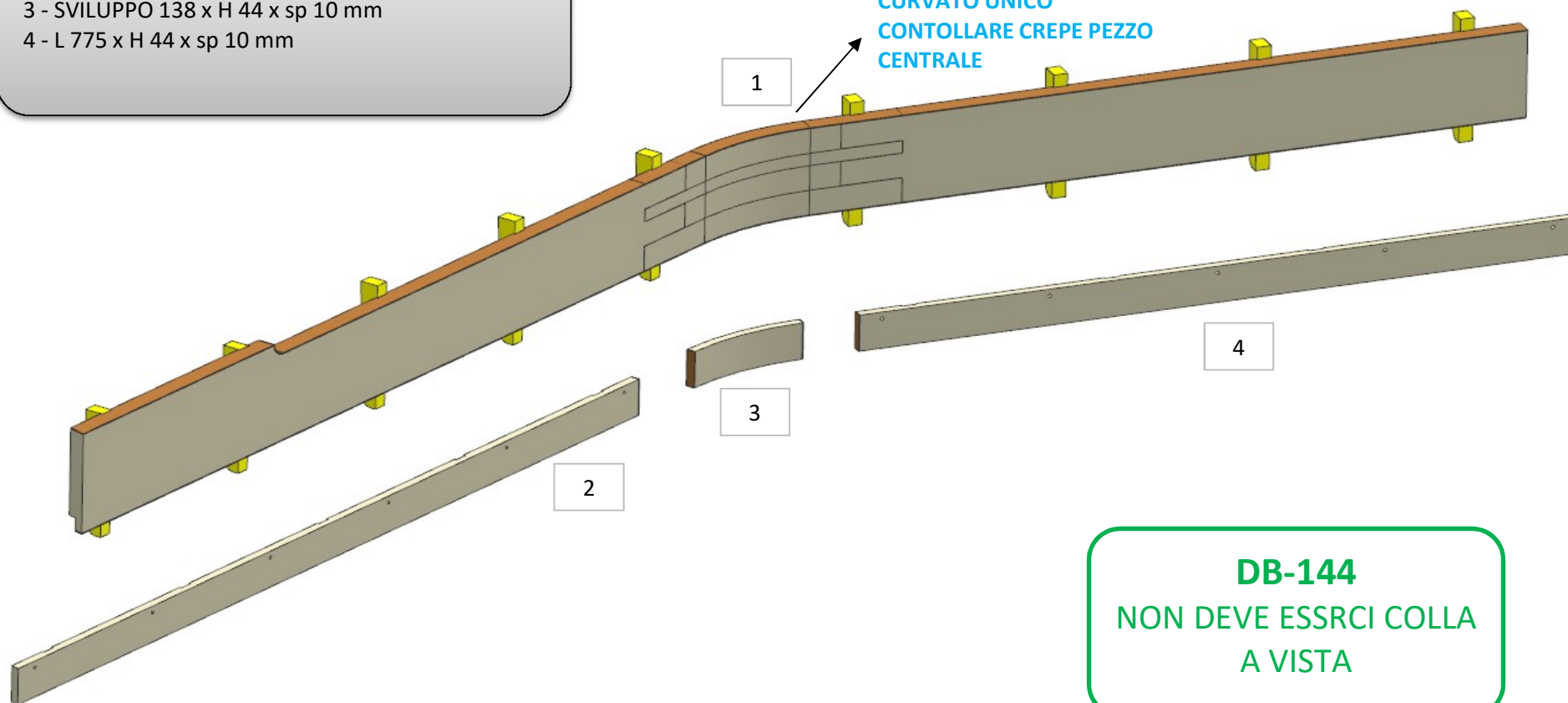

DB-144
NON DEVE ESSRCI COLLA
A VISTA

AZ68F

DA MAT. 265 REV. 29-04-2024

LOCALE	CODICE	DESCRIZIONE COMPONENTE	FINITURA	Q.TA	OPERATORE
SALONE	AZ68F-R02_SM01	GRADINO ALTO	LASTRA TEAK	1	Damiano

1 - L 1633 (sviluppo) x H 30 x sp 50 mm



202
SPIGOLO SMUSSATO.
ra. 2mm

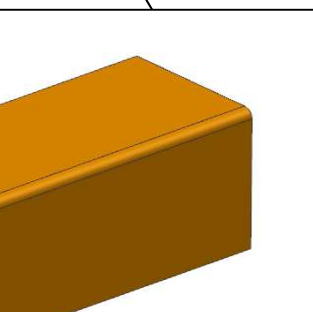

DETTAGLIO SPIGOLO

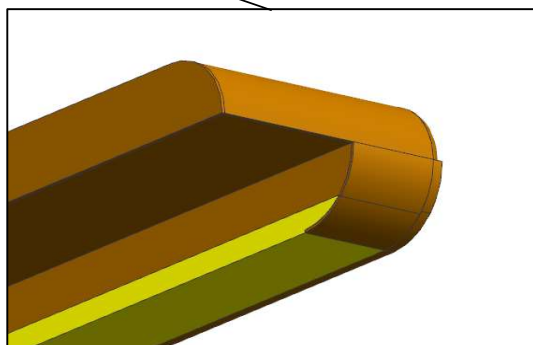

DETTAGLIO RETRO

AZ68F

DA MAT.265 REV. 29-04-2024

LOCALE	CODICE	DESCRIZIONE COMPONENTE	FINITURA	Q.TA	OPERATORE
SALONE	AZ68F-L01_SN01	SPES COPERTA GRADINO + DIVANI	LACCATO BRONZO	3	Damiano

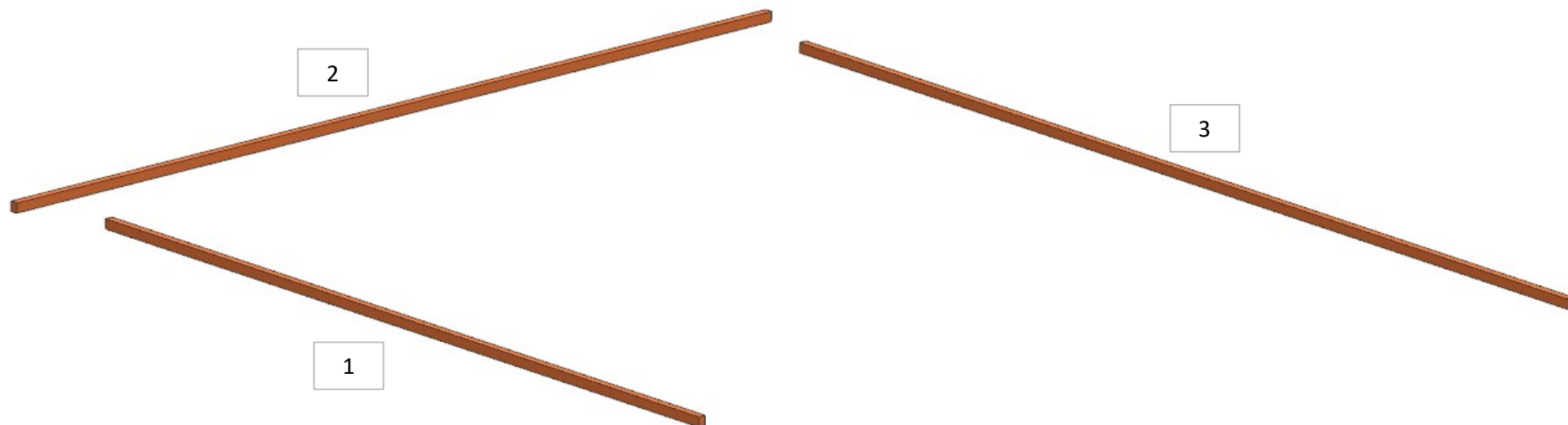

- 1 - L 1977 x H 27 x sp 19 mm
- 2 - L 2311 x H 27 x sp 19 mm
- 3 - L 2567 x H 27 x sp 19 mm

AZ68F

DA MAT.216

REV. 20-04-2021

LOCALE	CODICE	DESCRIZIONE COMPONENTE	FINITURA	Q.TA	OPERATORE
SALONE	AZ68F-MG_SO01	COMODINO DIVANO SX POPPA			Damiano

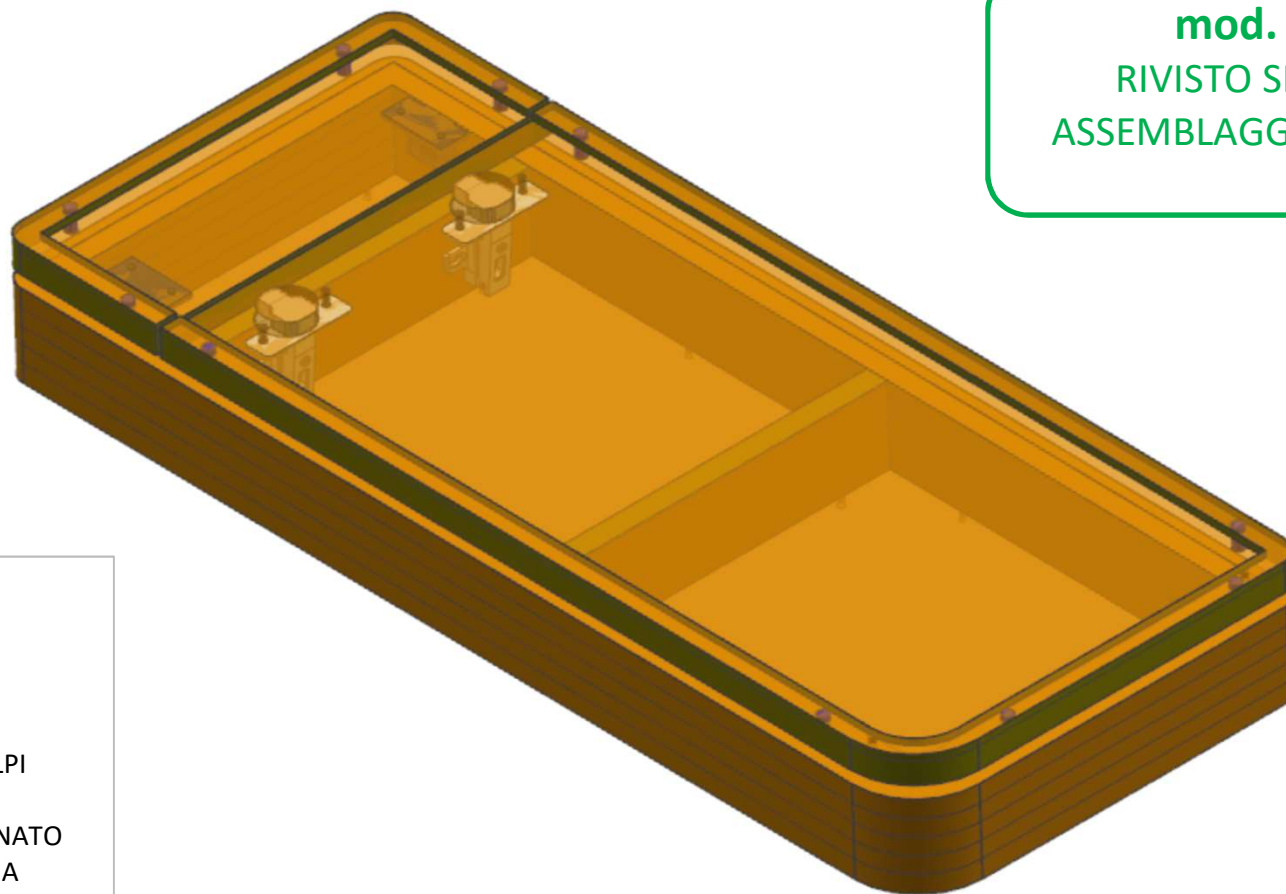

mod. int.
RIVISTO SISTEMA
ASSEMBLAGGIO MOBILE

FERRAMENTA:

- N° 2 - CERNIERA PIANA
- N° 2 - Basetta H6
- N° 8 - ANKOR BORGHI
- N° 2 - GOMMINO PARACOLPI
- N° 2 - KEKU FRONTALE
- N° 1 - PISTONE GAS FRIZIONATO
- N° 20 - BUSSOLA ZAMA 6MA

AZ68F

DA MAT. 216 REV. 29-04-2024

LOCALE	CODICE	DESCRIZIONE COMPONENTE	FINITURA	Q.TA	OPERATORE
SALONE	AZ68F-R01_SO01	COMODINO DIVANO SX POPPA	LASTRA TEAK	7	Damiano

- 1 - L 300 x H 600 x sp 25 mm
- 2 - L 300 x H 124 x sp 25 mm
- 3 - L 267.5 x H 694.5 x sp 16 mm
- 4 - L 236 x H 71 x sp 16 mm
- 5 - L 236 x H 71 x sp 16 mm
- 6 - L 236 x H 71 x sp 16 mm
- 7 - L 727 x H 695 x 16 mm

FERRAMENTA:

- N° 2 - CERNIERA PIANA
- N° 2 - BASETTA H6
- N° 8 - ANKOR BORGHI
- N° 2 - GOMMINO PARACOLPI
- N° 2 - KEKU FRONTALE
- N° 1 - PISTONE GAS FRIZIONATO
- N° 20 - BUSSOLA ZAMA 6MA

ELEMENTO DA MONTARE:
MG_SO01
 e spedire con un unico imballo

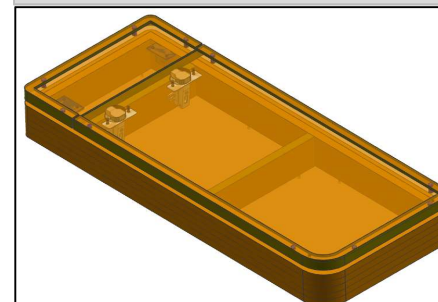

mod. int.
 RIVISTO SISTEMA
 ASSEMBLAGGIO MOBILE

consonni&c

AZ68F

DA MAT. 201 REV. 29-04-2024

LOCALE	CODICE	DESCRIZIONE COMPONENTE	FINITURA	Q.TA	OPERATORE
SALONE	AZ68F-R01_SS01	STRUTTURA DIVANO	LASTRA CHIARA	4	Damiano

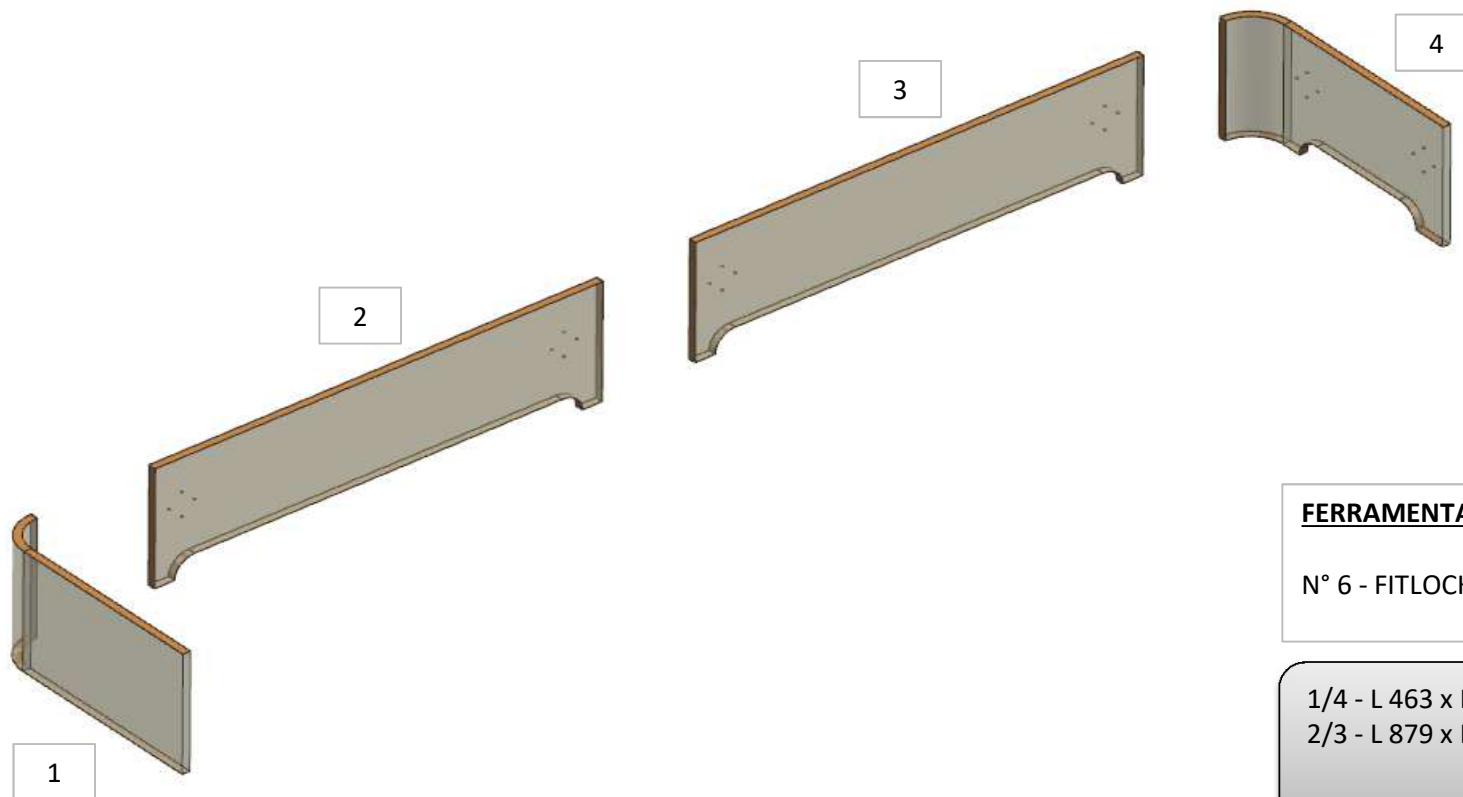

FERRAMENTA:
N° 6 - FITLOCK M/F

1/4 - L 463 x H 250 x sp 16mm
2/3 - L 879 x H 250 x sp 16mm

AZ68F

DA MAT. 201 REV. 29-04-2024

LOCALE	CODICE	DESCRIZIONE COMPONENTE	FINITURA	Q.TA	OPERATORE
SALONE	AZ68F-L01_SS01	STRUTTURA DIVANO	LACCATO MOGANO 100 GLOSS	3	Damiano

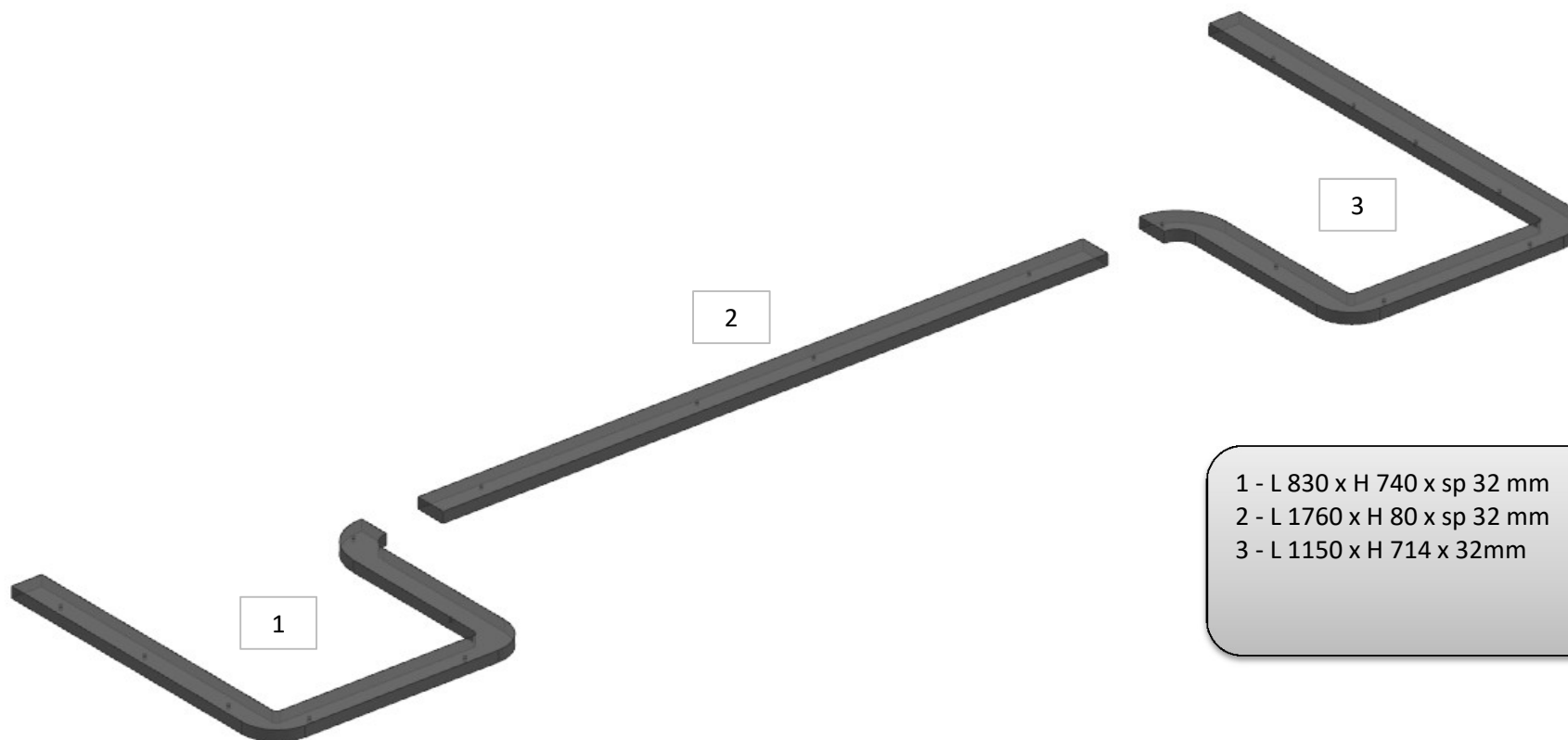

- 1 - L 830 x H 740 x sp 32 mm
- 2 - L 1760 x H 80 x sp 32 mm
- 3 - L 1150 x H 714 x 32mm

AZ68F

REV. 29-04-2024

LOCALE	CODICE	DESCRIZIONE COMPONENTE	FINITURA	Q.TA	OPERATORE
SALONE	AZ68F-ST01	CORNICE TV OPT	OKOUME' GREZZO	1	Damiano

1 - L 1079 x H 724 x 15 mm

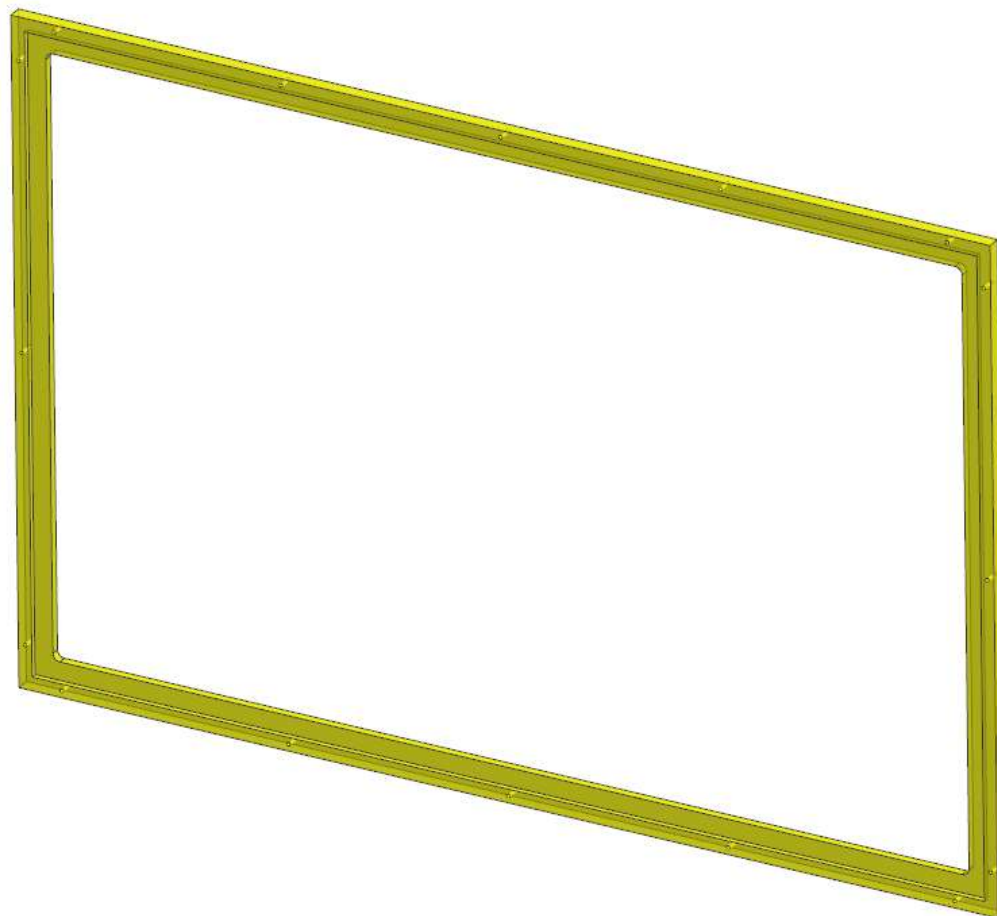

AZ68F

DA MAT. 201 REV. 20-04-2021

LOCALE	CODICE	DESCRIZIONE COMPONENTE	FINITURA	Q.TA	OPERATORE
SALONE	AZ68F-MG_ST01	CORNICE TV OPT			Damiano

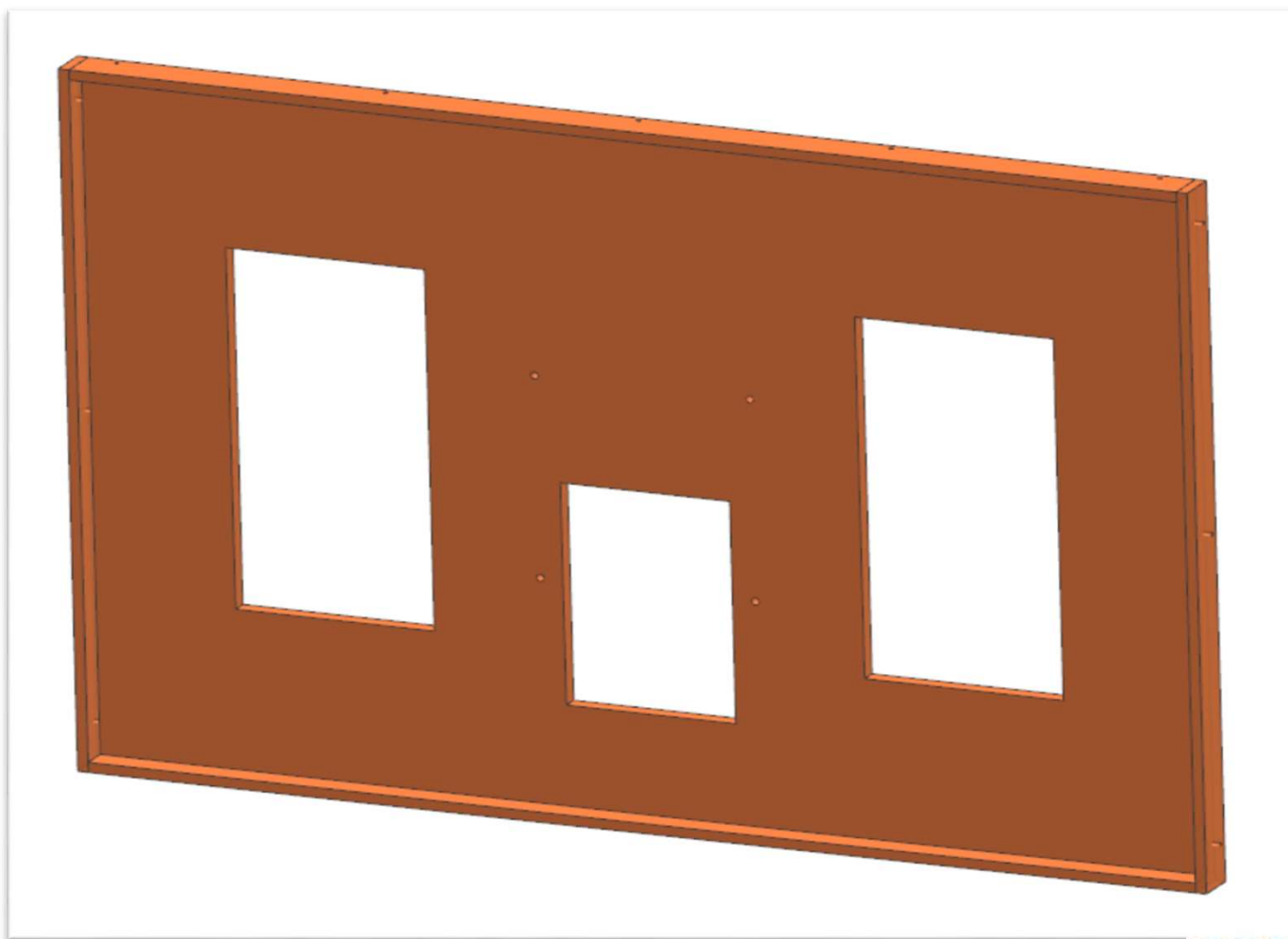

consonni&c

AZ68F

DA MAT. 201 REV. 29-04-2024

LOCALE	CODICE	DESCRIZIONE COMPONENTE	FINITURA	Q.TA	OPERATORE
SALONE	AZ68F-L01_ST01	CORNICE TV OPT	LACCATO BRONZO	5	Damiano

1 - L 1029 x H 675 x 15 mm
2/3 - L 1029 x H 40 x 10 mm
4/5 - L 695 x H 40 x 10mm

ELEMENTO DA MONTARE:
MG_ST01
e spedire con un unico imballo

