

# AZ68F

DA MAT.265

REV. 29-04-2024

LOCALE	CODICE	DESCRIZIONE COMPONENTE	FINITURA	Q.TA	OPERATORE
SALONE	AZ68F-SB01	MURATA BASSA SX POPPA	OKOUME' GREZZO \ ANTIROMBO	3	Damiano

**MOD. INT.**  
PLENUM DIVISO  
DA STRUTTURA.  
VERNICIARE CON  
ANTI-ROMBO

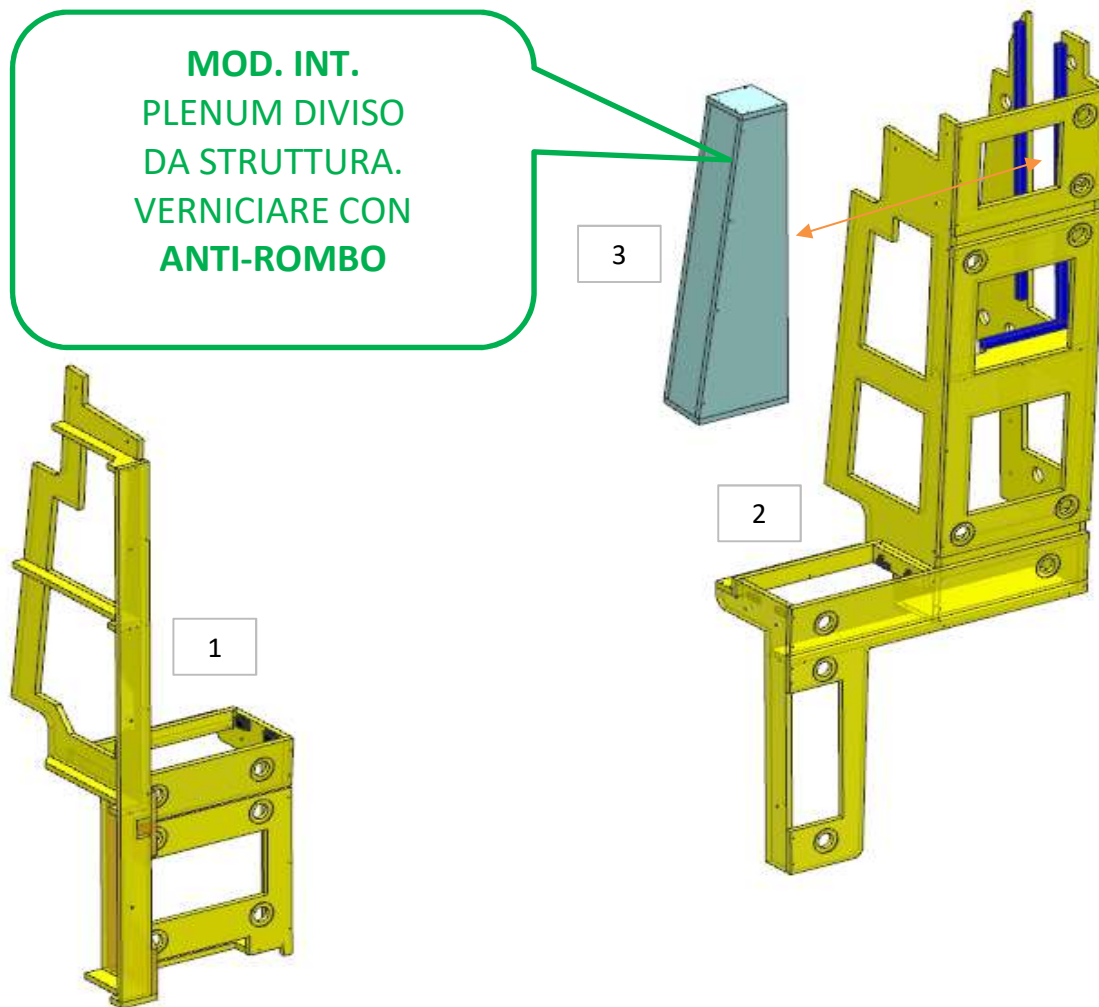

- 1 - L 524.5 x H 1585 x 517 mm
- 2 - L 796 x H 2025 x 432.5 mm
- 3 - L 136 x H 798 x 238 mm

**FERRAMENTA:**

- N° 8 - SOUTHCO
- N° 28 - FITLOCK MASCHIO
- N° 28 - FITLOCK FEMMINA
- N° 14 - VITI 6MA
- N° 2 - BUSSOLA ZAMA 6MA

# AZ68F

REV. 25-05-2021

LOCALE	CODICE	DESCRIZIONE COMPONENTE	FINITURA	Q.TA	OPERATORE
SALONE	AZ68F-I01_SB01	MURATA BASSA SX POPPA	OKOUME' GREZZO	4	Dante

- 1 - L 426.5 x H 423 x sp 15 mm
- 2 - L 2539 x H 150.5 x sp 15 mm
- 3 - L 578 x H 185 x sp 15 mm
- 4 - L 336.5 x H 182.5 x sp 30 mm

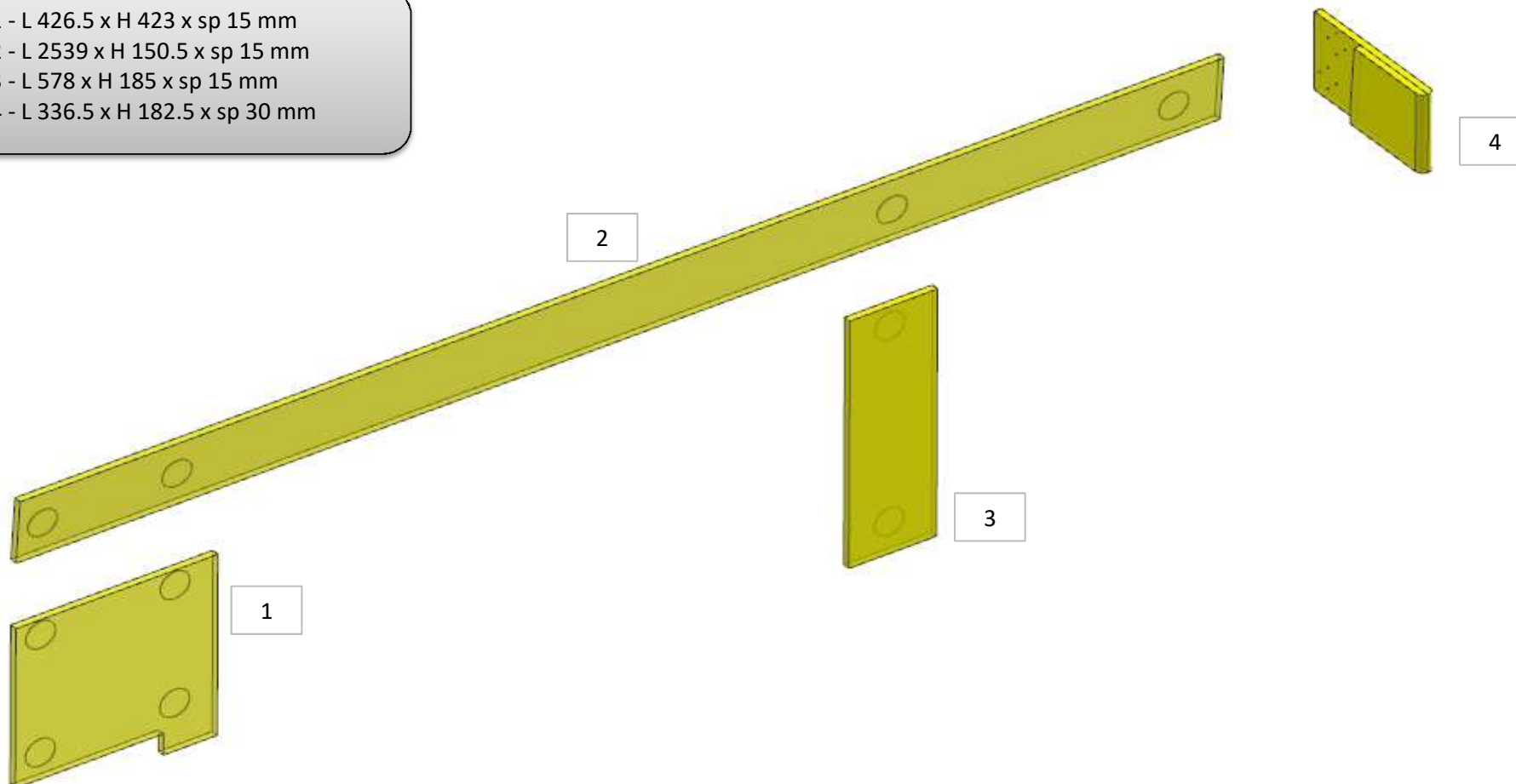

# AZ68F

DA MAT.265

REV. 29-04-2024

LOCALE	CODICE	DESCRIZIONE COMPONENTE	FINITURA	Q.TA	OPERATORE
SALONE	AZ68F-SD01	PLENUM AC MURATA SX	OKOUME' GREZZO \ ANTIROMBO	2	Damiano

1 - L 2200 x H 193 x 283 mm  
2 - L 1846 x H 156 x 293mm

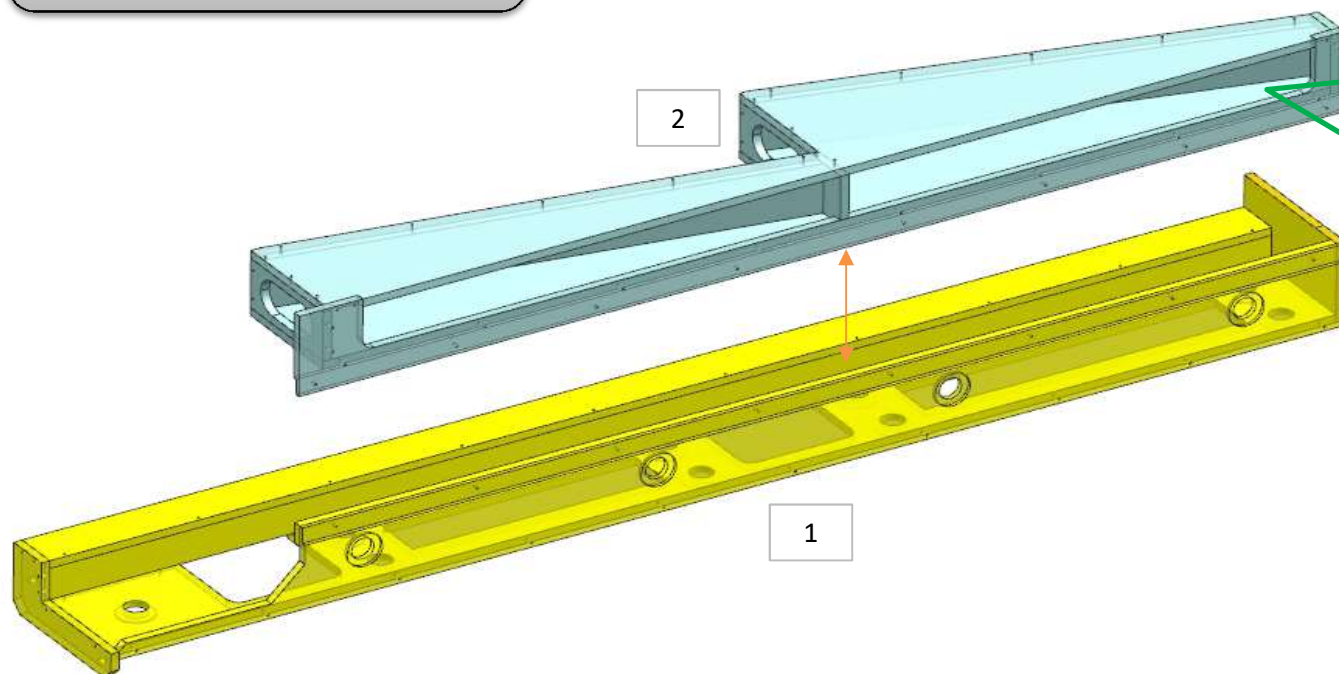

**MOD. INT.**  
PLENUM DIVISO  
DA STRUTTURA.  
VERNICIARE CON  
ANTI-ROMBO

**FERRAMENTA:**

N° 15 - FITLOCK MASCHIO  
N° 13 - FITLOCK FEMMINA  
N° 4 - BUSSOLA ZAMA 6MA

# AZ68F

DA MAT. 203 REV. 25-05-2021

LOCALE	CODICE	DESCRIZIONE COMPONENTE	FINITURA	Q.TA	OPERATORE
SALONE	AZ68F-I01_SD01	PLENUM AC MURATA SX	OKOUME' GREZZO	1	Dante

1 - L 2122.5 x H 61.5 x sp 10 mm

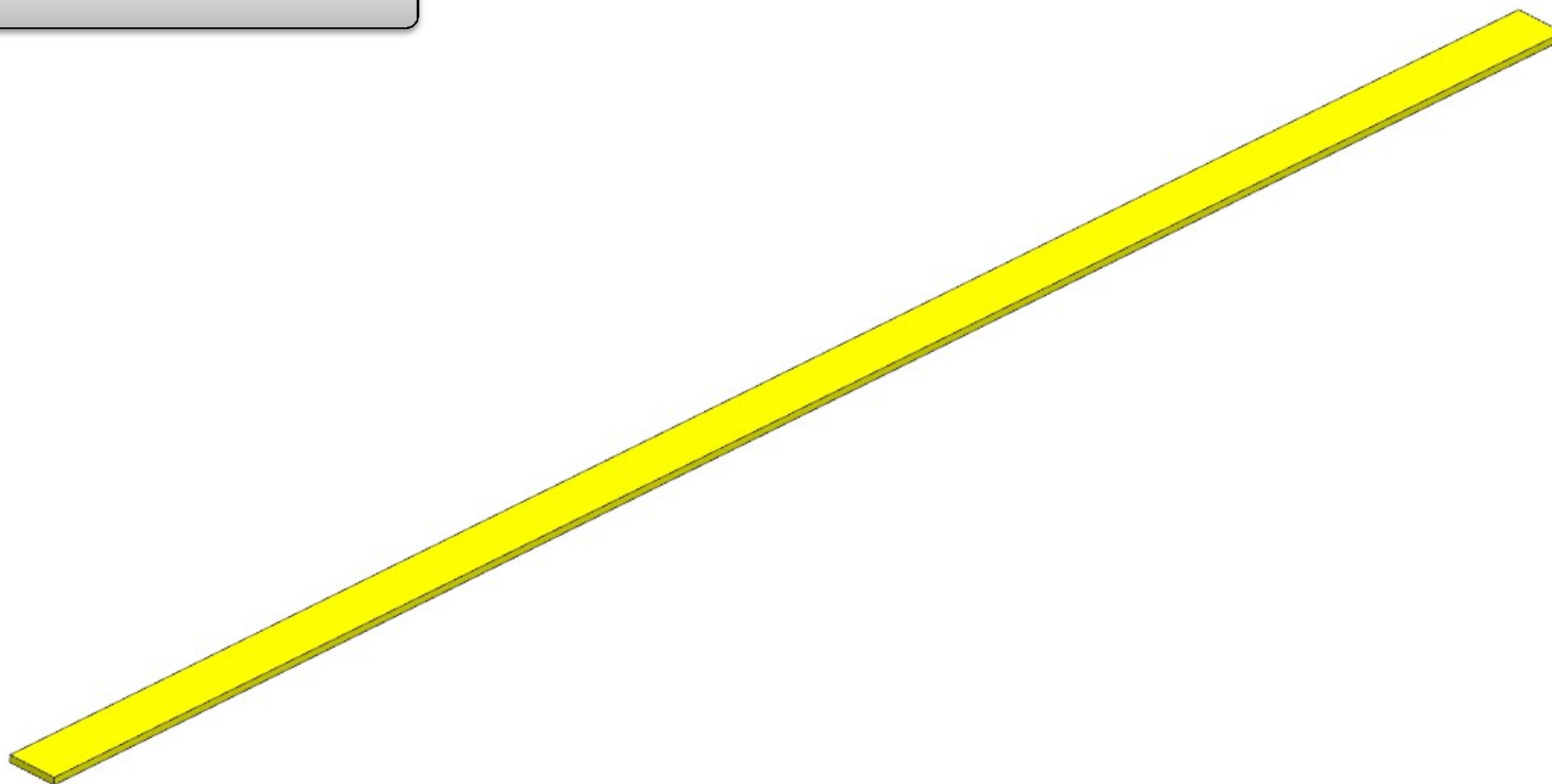

# AZ68F

DA MAT. 265 REV. 29-04-2024

LOCALE	CODICE	DESCRIZIONE COMPONENTE	FINITURA	Q.TA	OPERATORE
SALONE	AZ68F-SE01	MURATA BASSA SX PRUA	OKOUME' GREZZO \ ANTIROMBO	3	Damiano

- 1 - L 1751 x H 497 x 196.5 mm
- 2 - L 1712.5 x H 1725 x 306.5 mm
- 3 - L 146 x H 1298 x 189 mm

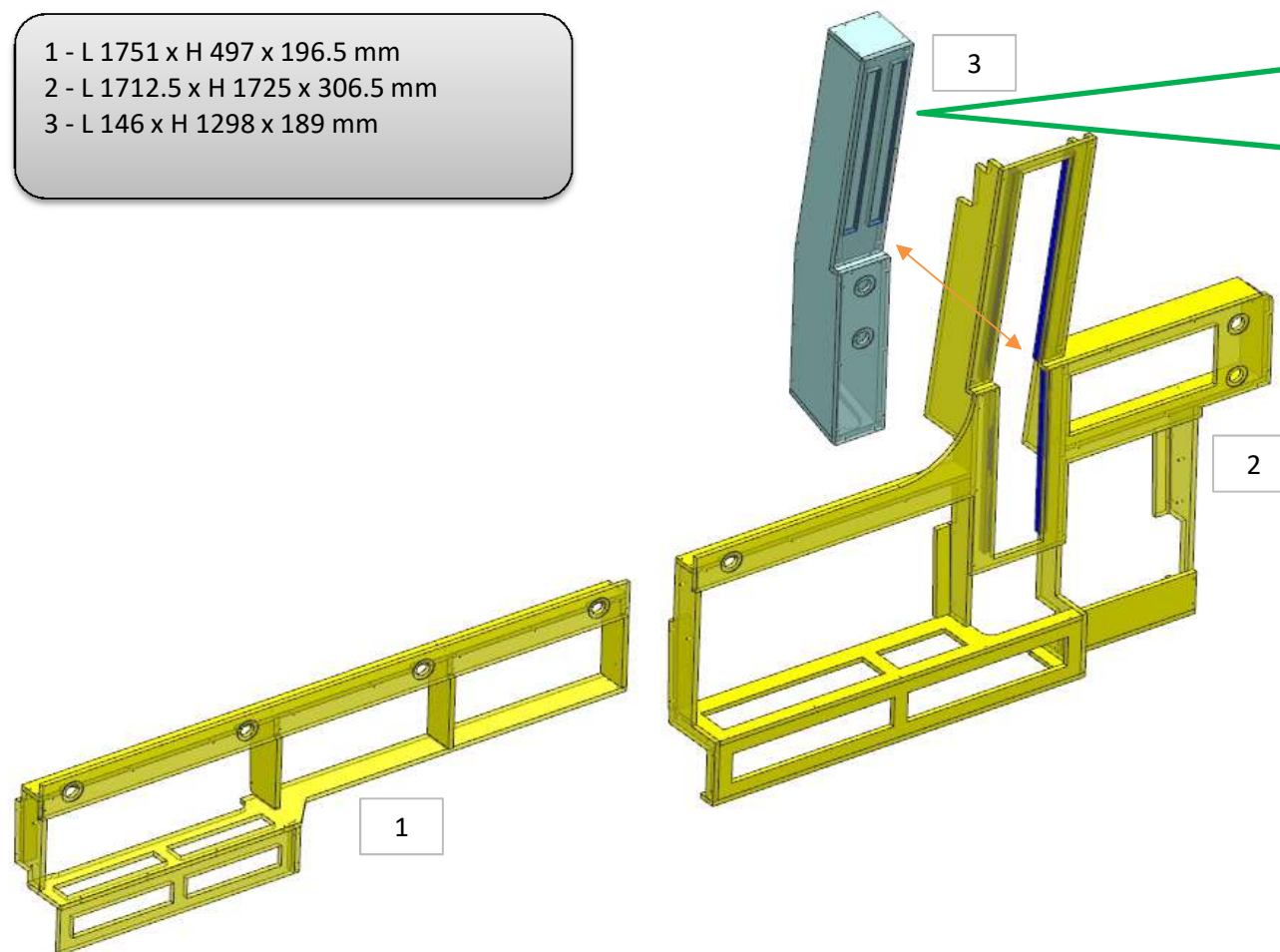

**MOD. INT.**  
**PLENUM DIVISO**  
**DA STRUTTURA. VERNICIARE**  
**CON**  
**ANTI-ROMBO**

**FERRAMENTA:**

- N° 9 - FITLOCK MASCHIO
- N° 9 - FITLOCK FEMMINA
- N° 6 - VITI 6MA

# AZ68F

DA MAT. 203 REV. 25-05-2021

LOCALE	CODICE	DESCRIZIONE COMPONENTE	FINITURA	Q.TA	OPERATORE
SALONE	AZ68F-I01_SE01	MURATA BASSA SX PRUA	OKOUME' GREZZO	4	Dante

- 1 - L 1727.5 x H 124 x sp 10 mm
- 2 - L 1727.5 x H 40 x sp 6 mm
- 3 - L 1723 x H 339 x sp 10 mm
- 4 - L 824.5 x H 193 x sp 6 mm

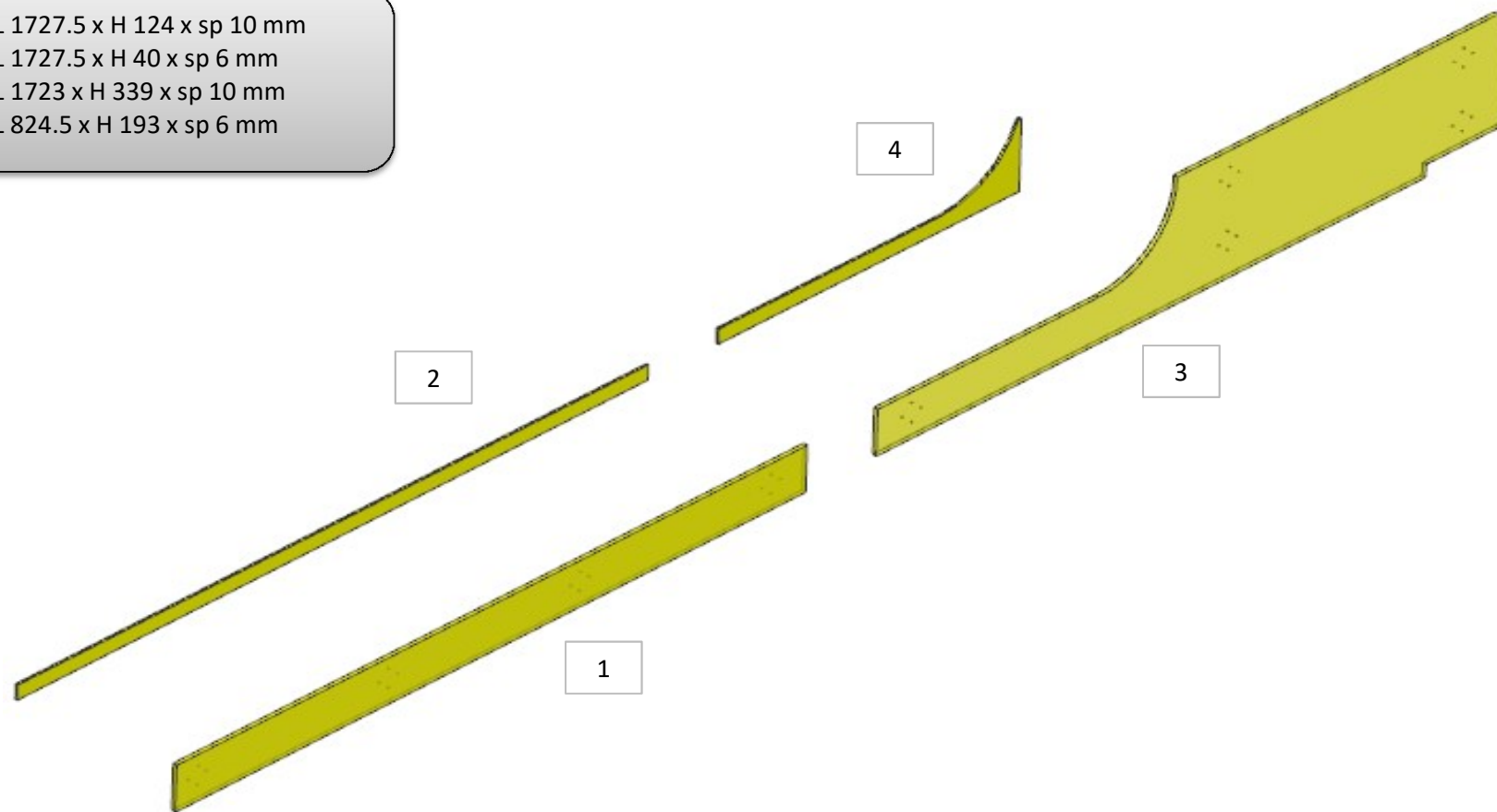

# AZ68F

DA MAT. 216 REV. 25-05-2021

LOCALE	CODICE	DESCRIZIONE COMPONENTE	FINITURA	Q.TA	OPERATORE
SALONE	AZ68F-I01_SG01	CASSAPANCA SX	OKOUME' GREZZO	2	Dante

1 - svilup. 1445 x sp. 6 mm  
2 - L 546 x H 260 x sp.23 mm

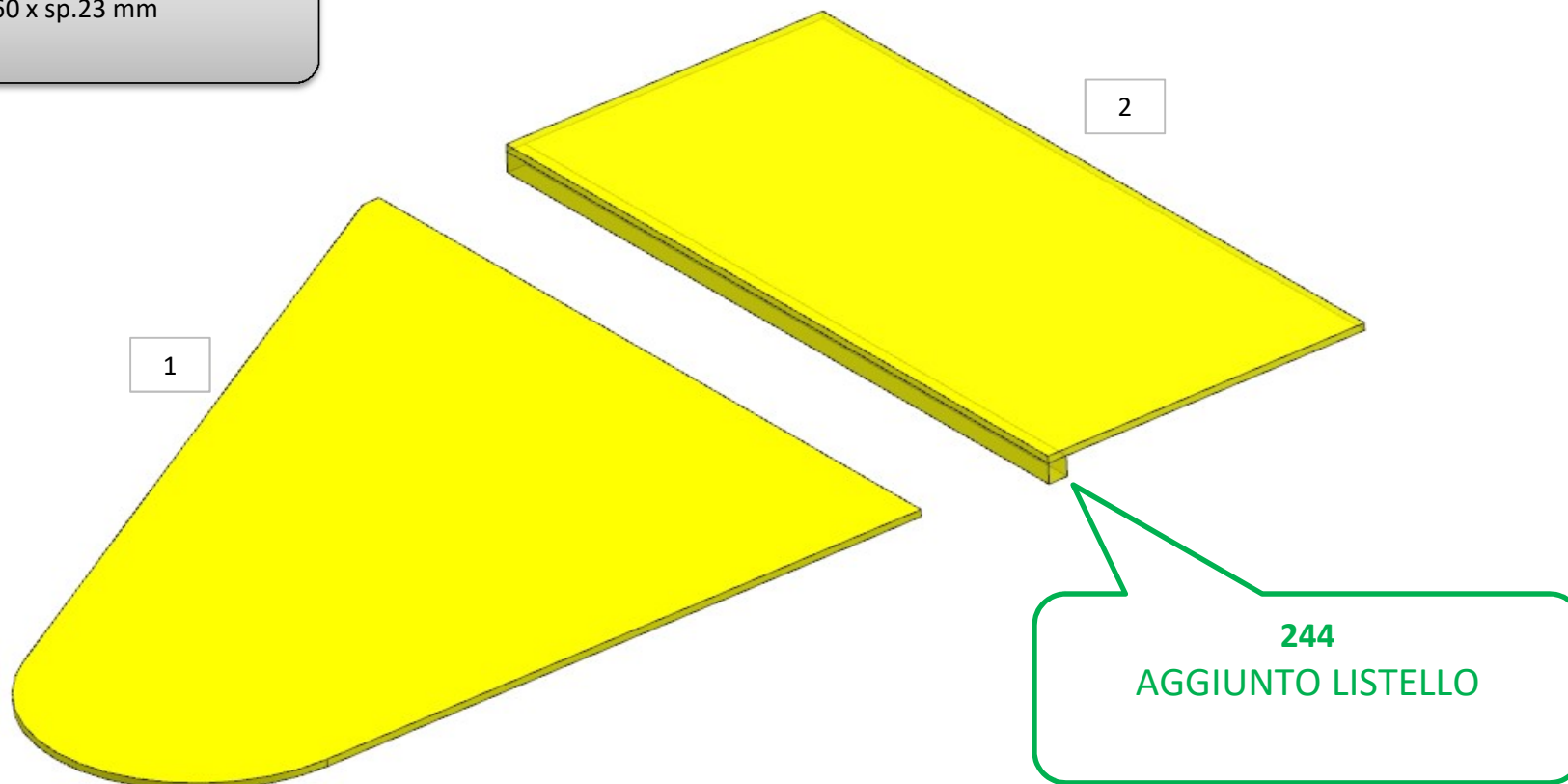

# AZ68F

REV. 29-04-2024

LOCALE	CODICE	DESCRIZIONE COMPONENTE	FINITURA	Q.TA	OPERATORE
SALONE	AZ68F-SH01	COLONNA POPPA MURATA DX	OKOUME' GREZZO	1	Dante

1 - L 350 x H 1928.5 x 338 mm

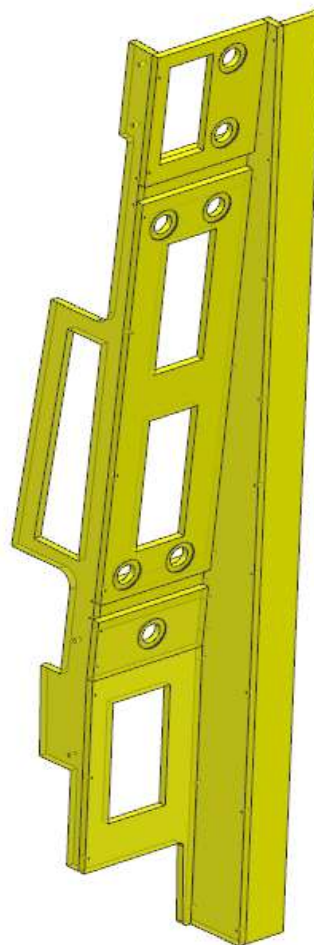

**FERRAMENTA:**

- N° 7 - FITLOCK MASCHIO
- N° 7 - FITLOCK FEMMINA
- N° 2 - VITI 6MA
- N° 2 - BUSSOLA ZAMA 6MA

# AZ68F

REV. 29-04-2024

LOCALE	CODICE	DESCRIZIONE COMPONENTE	FINITURA	Q.TA	OPERATORE
SALONE	AZ68F-SI01	STRUTTURA MURATA BASSA DX	OKOUME' GREZZO	1	Dante

1 - L 2114 x H 717 x 140 mm

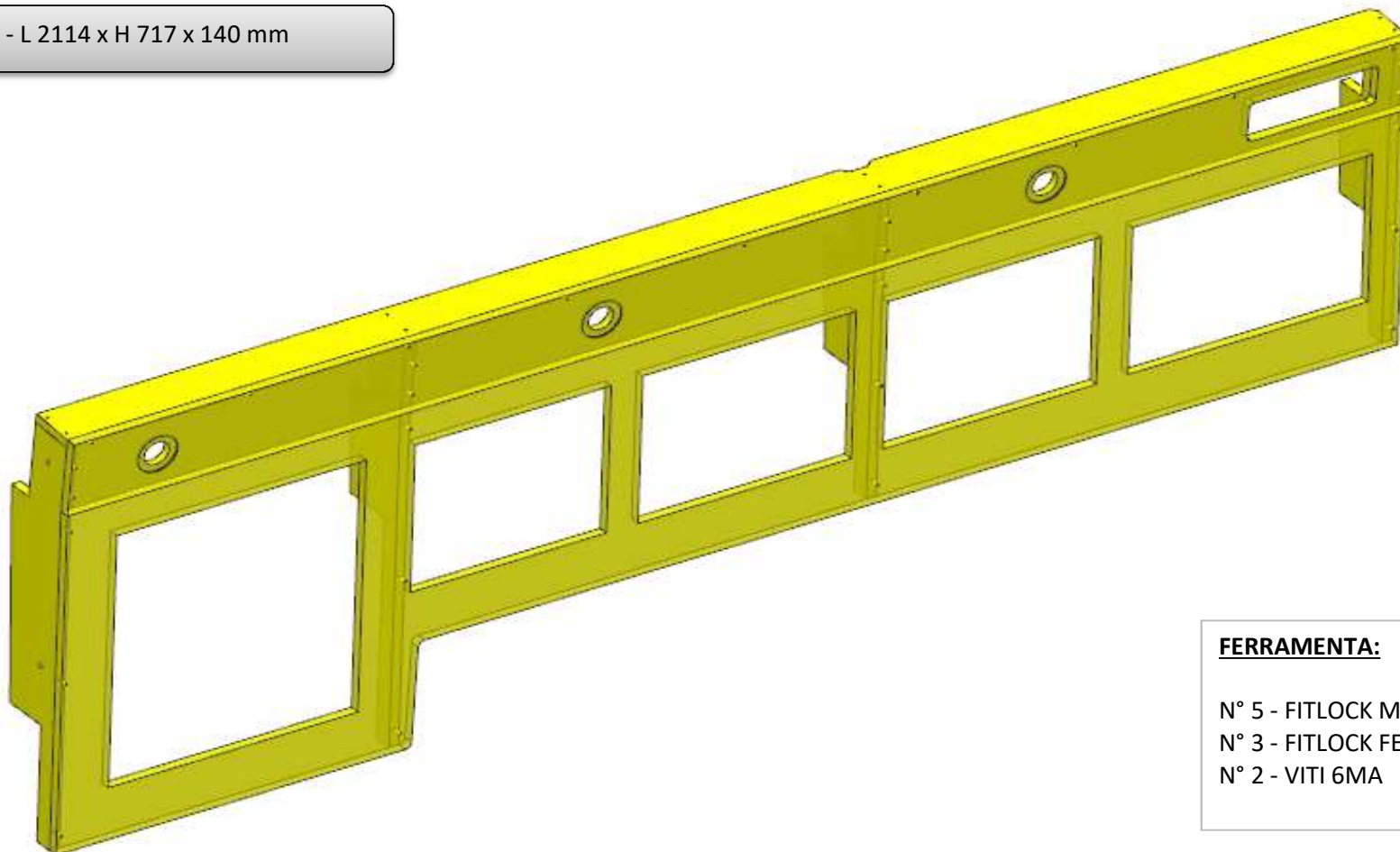

**FERRAMENTA:**

N° 5 - FITLOCK MASCHIO  
N° 3 - FITLOCK FEMMINA  
N° 2 - VITI 6MA

# AZ68F

REV. 25-05-2021

LOCALE	CODICE	DESCRIZIONE COMPONENTE	FINITURA	Q.TA	OPERATORE
SALONE	AZ68F-I01_SI01	STRUTTURA MURATA BASSA DX	OKOUME' GREZZO	1	Dante

1 - L 3006 x H 152.5 x sp 15 mm

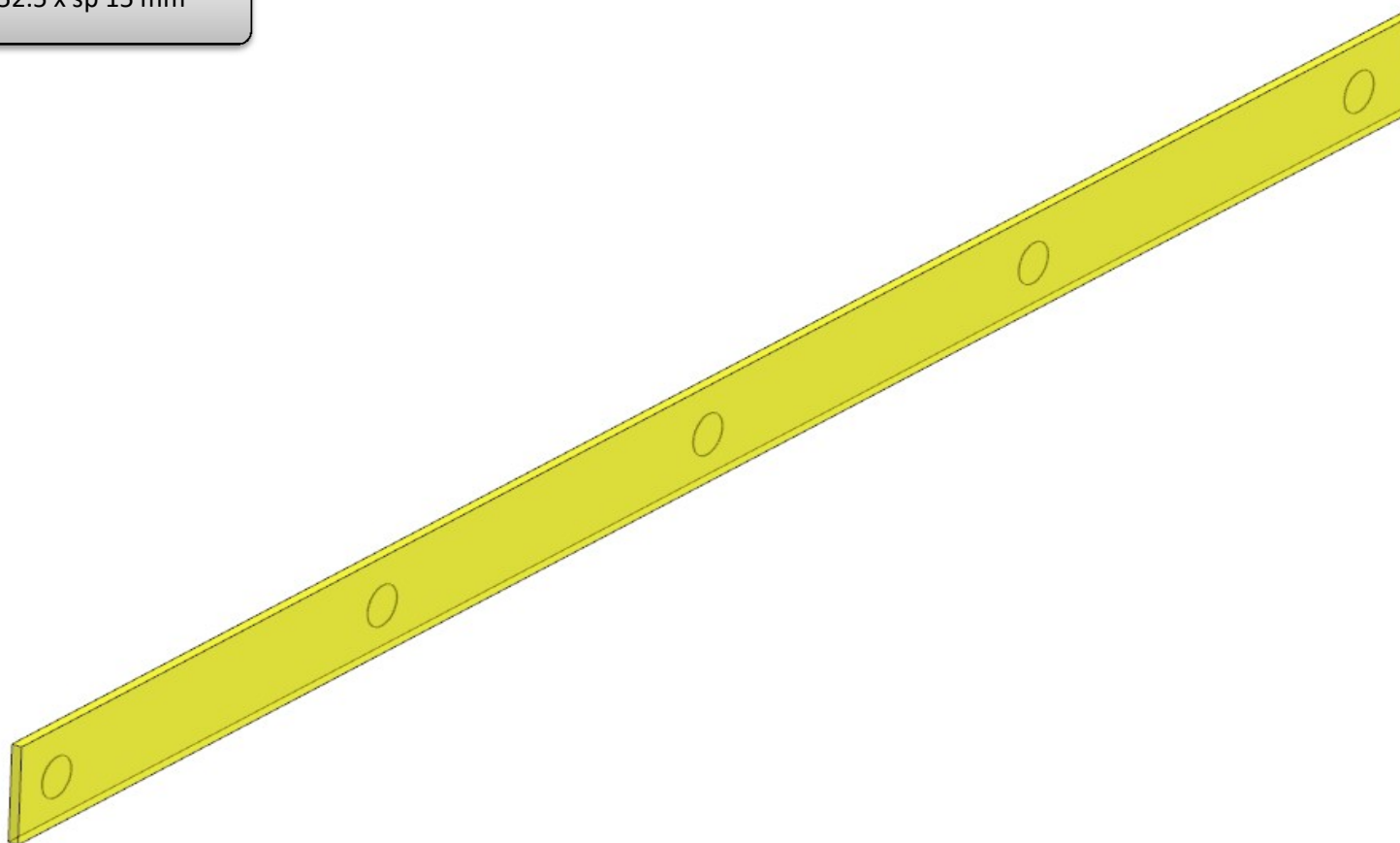

# AZ68F

DA MAT.216

REV. 29-04-2024

LOCALE	CODICE	DESCRIZIONE COMPONENTE	FINITURA	Q.TA	OPERATORE
SALONE	AZ68F-SL01	COLONNA PLENUM DX PRUA	OKOUME' GREZZO \ ANTIROMBO	2	Dante

1 - L 2439 x H 202 x 137 mm  
2 - L 677 x H 1930 x 273 mm

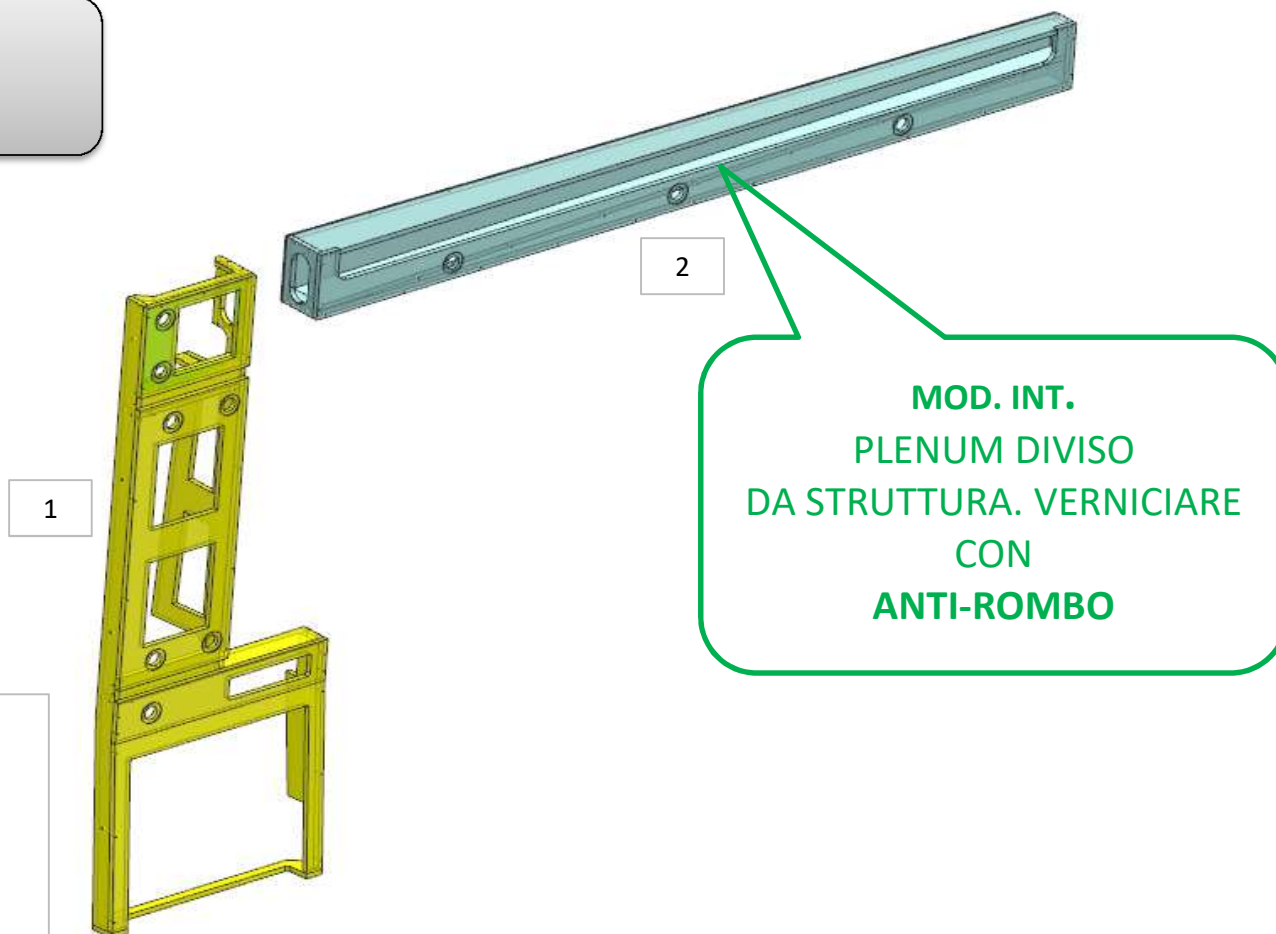

**FERRAMENTA:**

N° 11 - FITLOCK MASCHIO  
N° 10 - FITLOCK FEMMINA  
N° 6 - VITI 6MA  
N° 2 - BUSSOLA ZAMA 6MA

# AZ68F

REV. 25-05-2021

LOCALE	CODICE	DESCRIZIONE COMPONENTE	FINITURA	Q.TA	OPERATORE
SALONE	AZ68F-I01_SL01	COLONNA PLENUM DX PRUA	OKOUME' GREZZO	1	Dante

1 - L 2430 x H 76 x sp 15 mm

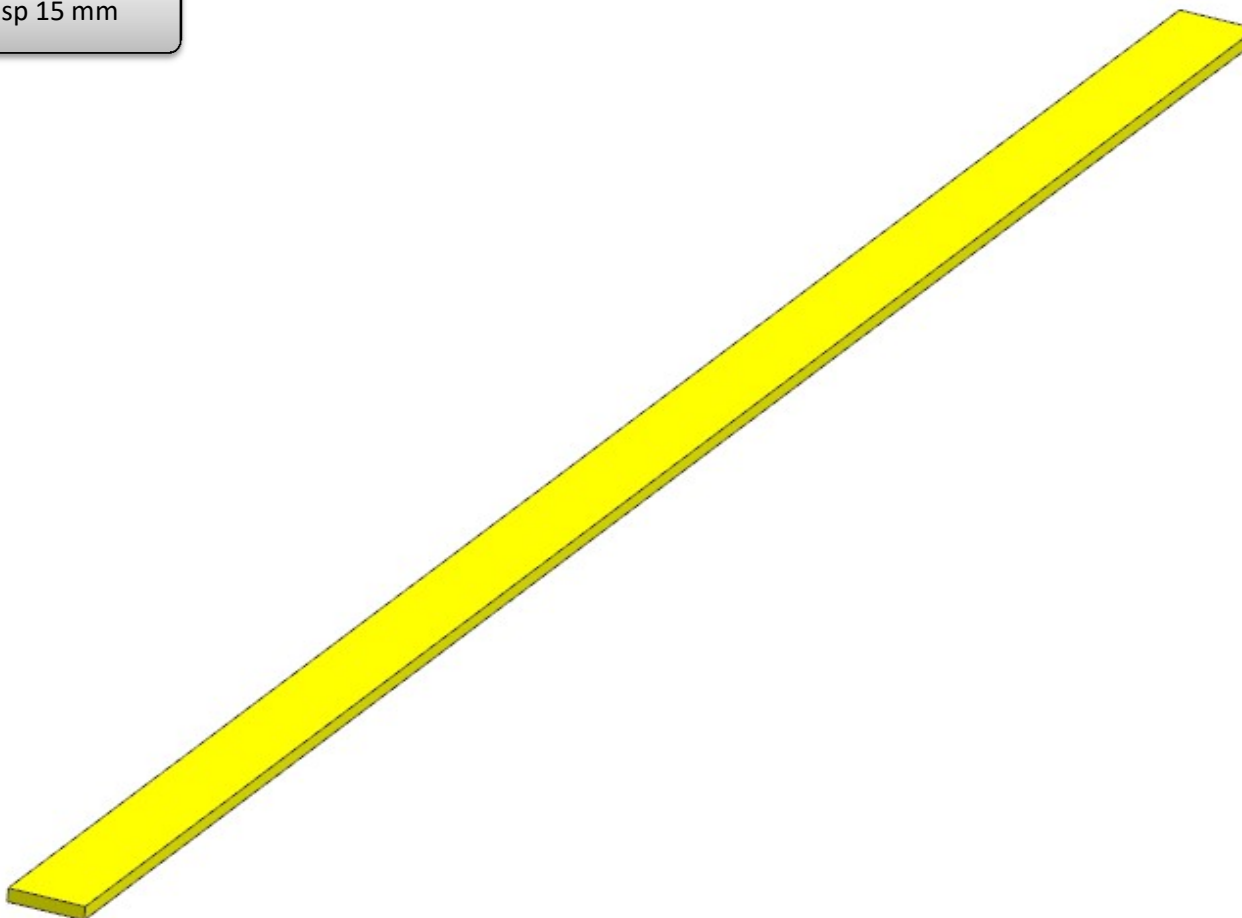

# AZ68F

DA MAT.265

REV. 29-04-2024

LOCALE	CODICE	DESCRIZIONE COMPONENTE	FINITURA	Q.TA	OPERATORE
SALONE	AZ68F-SN01	SPES COPERTA GRADINO + DIVANI	OKOUME' GREZZO	3	Damiano

- 1 - L 1977 x H 153 x 19 mm
- 2 - L 2311 x H 150 x 43 mm
- 3 - L 2567 x H 153 x 19 mm

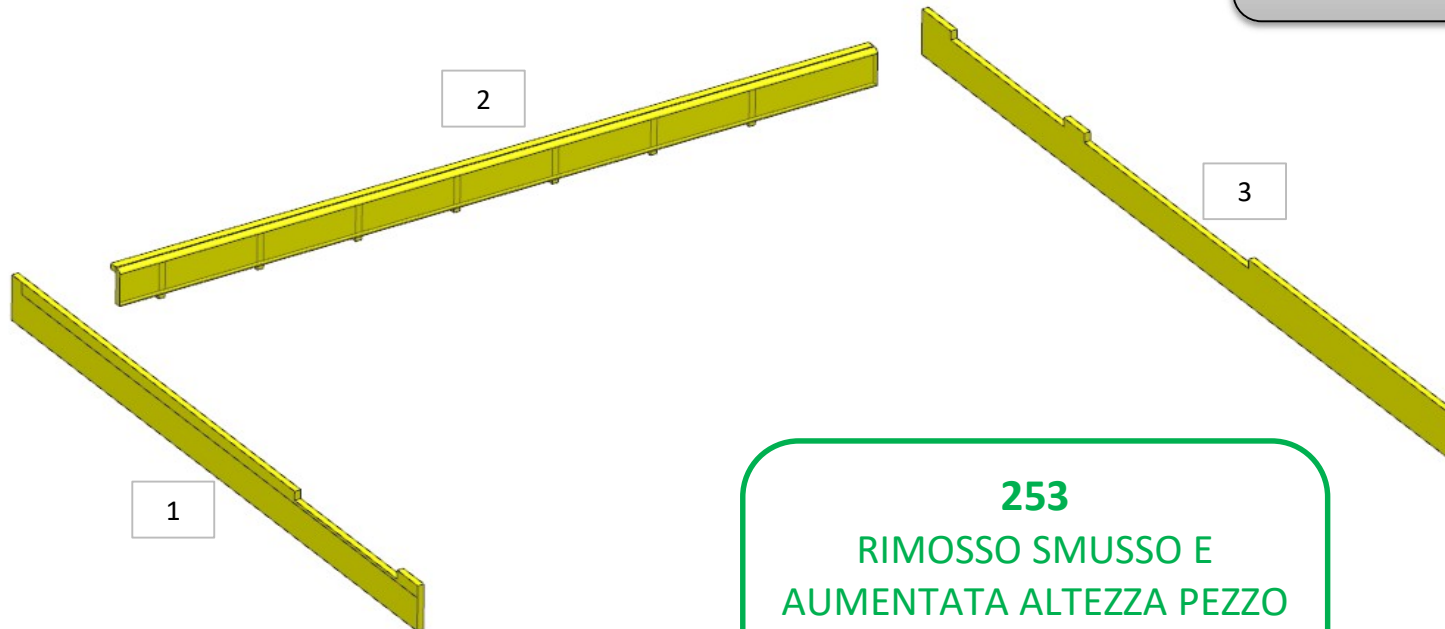

**253**  
RIMOSSO SMUSSO E  
AUMENTATA ALTEZZA PEZZO  
N.1 E N.3