

# AZ68F

DA MAT. 216 Rev. 29-04-2024

LOCALE	CODICE	DESCRIZIONE COMPONENTE	FINITURA	Q.TA	OPERATORE
SALONE	AZ68F-MF_SG01\SG02	CASSAPANCA SX			Damiano

## FERRAMENTA:

- N° 2 - CERNIERA PIANA diam 40
- N° 2 - Basetta H9
- N° 8 - ANKOR BORGHI
- N° 2 - GOMMINO PARACOLPI
- N° 1 - BRACCETTO LIVENZA 244 - 45N
- N° 8 - BUSSOLA ZAMA 6MA

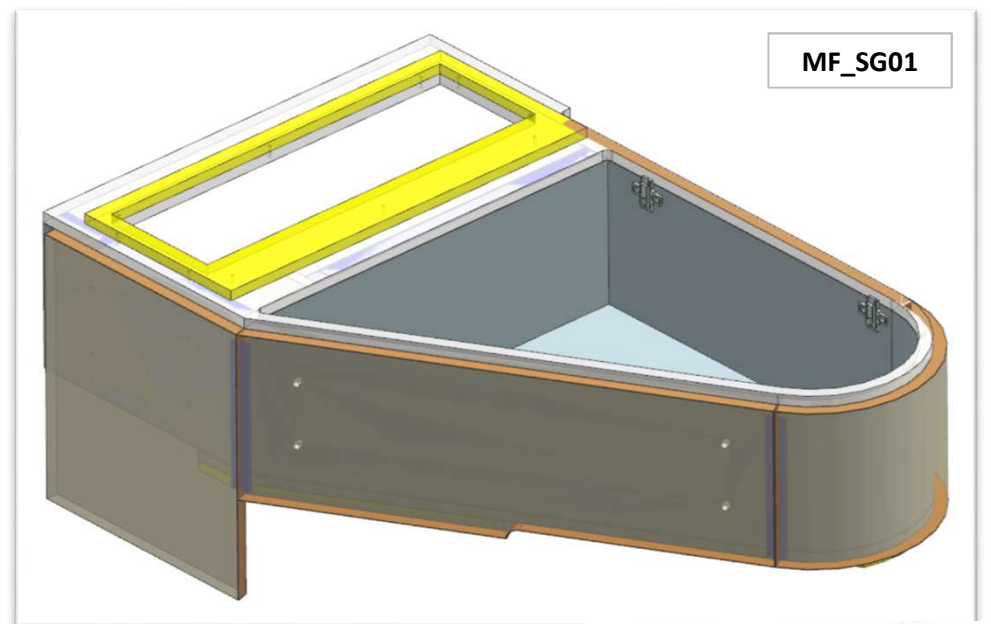
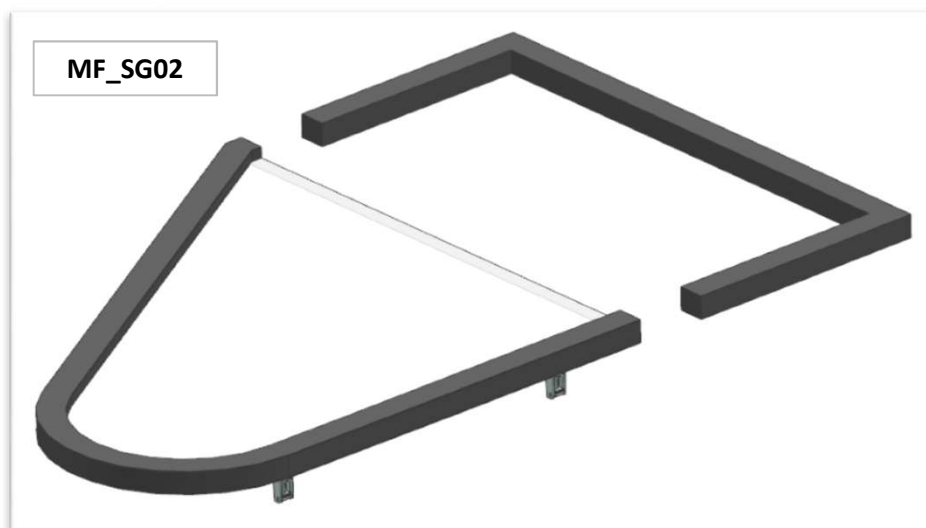

consonni&c

# AZ68F

DA MAT. 216 REV. 29-04-2024

LOCALE	CODICE	DESCRIZIONE COMPONENTE	FINITURA	Q.TA	OPERATORE
SALONE	AZ68F-SG01	CASSAPANCA SX	LAMINATO NADIR	1	Damiano

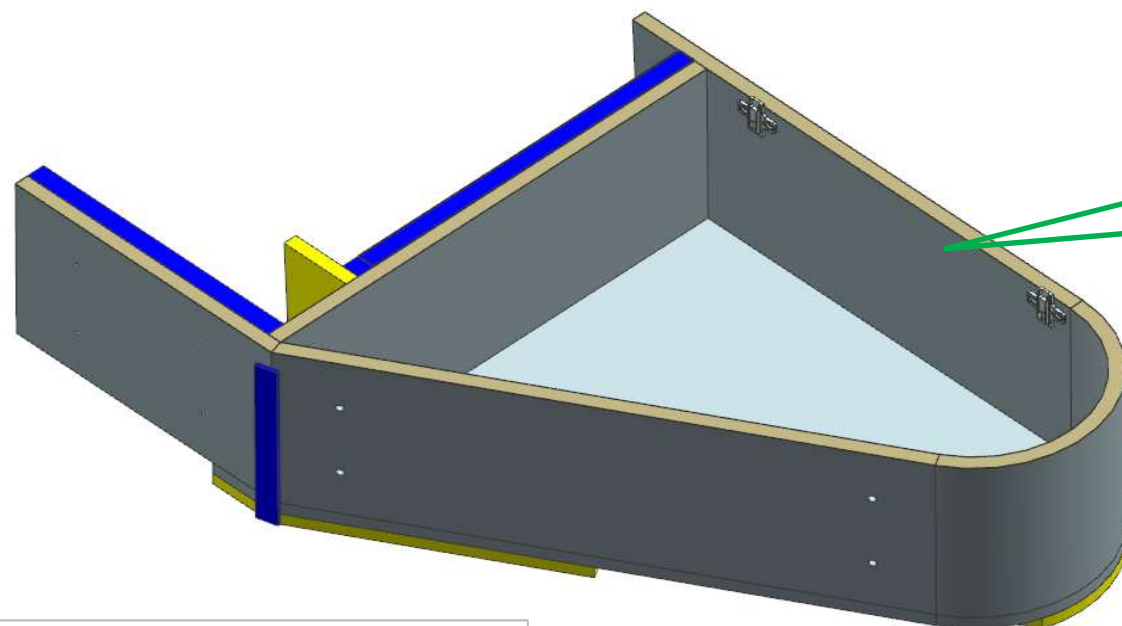

244  
MODIFICATO SENSO  
APERTURA ANTA

ELEMENTO DA MONTARE con:  
R01\_SG01  
L01\_SG01  
e spedire con un unico imballo

## FERRAMENTA:

- N° 2 - CERNIERA PIANA diam 40
- N° 2 - Basetta H9
- N° 8 - ANKOR BORGHI
- N° 2 - GOMMINO PARACOLPI
- N° 1 - BRACCETTO LIVENZA 244 - 45N
- N° 8 - BUSSOLA ZAMA 6MA

L01\_SG01

R01\_SG01

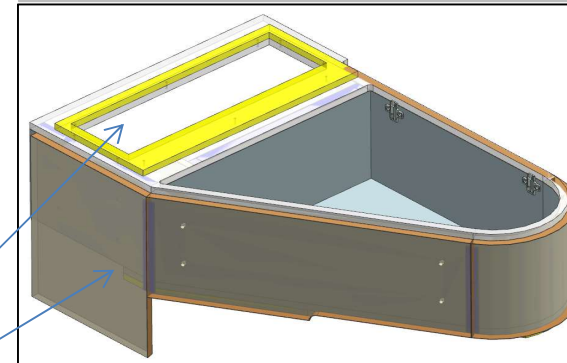

# AZ68F

DA MAT. 216 REV. 29-04-2024

LOCALE	CODICE	DESCRIZIONE COMPONENTE	FINITURA	Q.TA	OPERATORE
SALONE	AZ68F-R01_SG01	CASSAPANCA SX	LASTRA CHIARA	4	Damiano

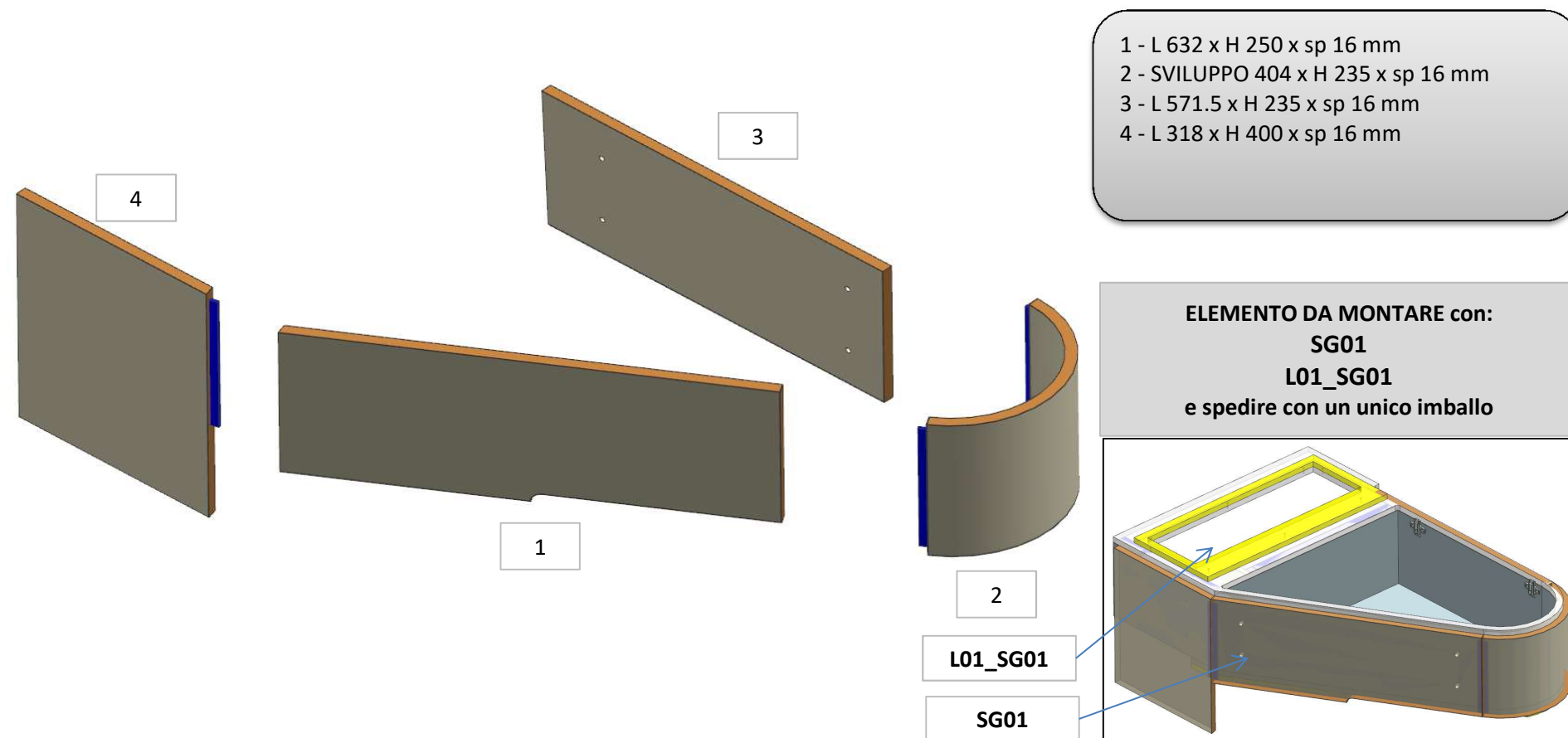

# AZ68F

DA MAT. 216 REV. 29-04-2024

LOCALE	CODICE	DESCRIZIONE COMPONENTE	FINITURA	Q.TA	OPERATORE
SALONE	AZ68F-L01_SG01	CASSAPANCA SX	LACCATO BIANCO ARTICO	2	Damiano

1 - L 594.5 x sp 16 mm  
2 - svilup. 1516.5 x sp 16 mm

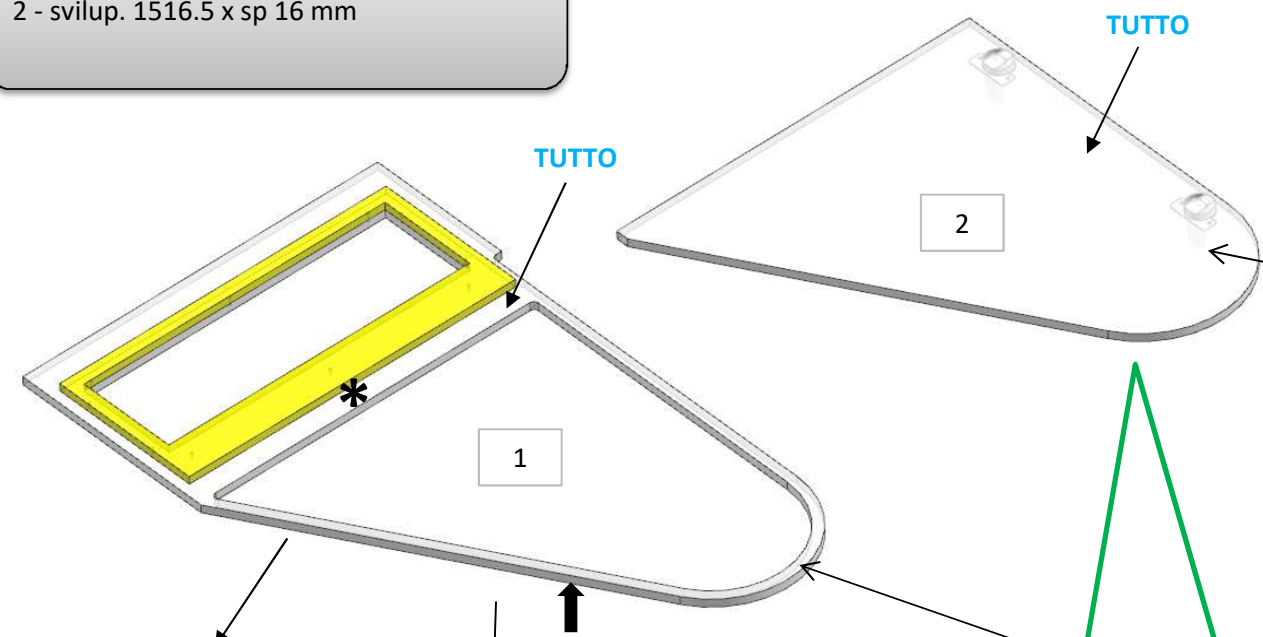

ELEMENTO DA MONTARE con:  
MF-SG02  
e spedire con un unico imballo

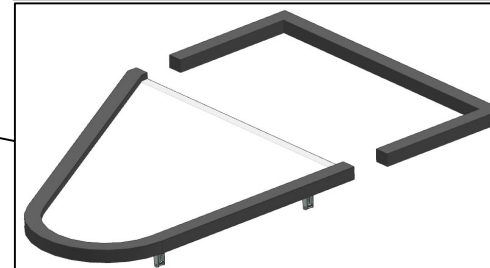

ELEMENTO DA MONTARE con:  
MF-SG01  
e spedire con un unico imballo

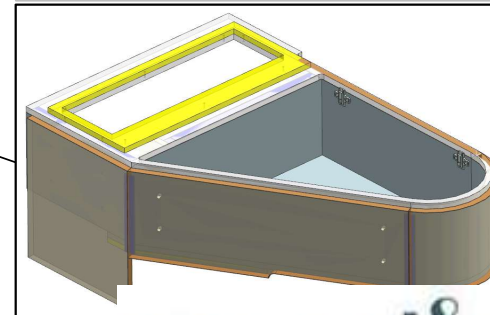

consonni&c

# AZ68F

DA MAT. 216 REV. 29-04-2024

LOCALE	CODICE	DESCRIZIONE COMPONENTE	FINITURA	Q.TA	OPERATORE
SALONE	AZ68F-L02_SG01	CASSAPANCA SX	LACCATO MOGANO 100 GLOSS	2	Damiano

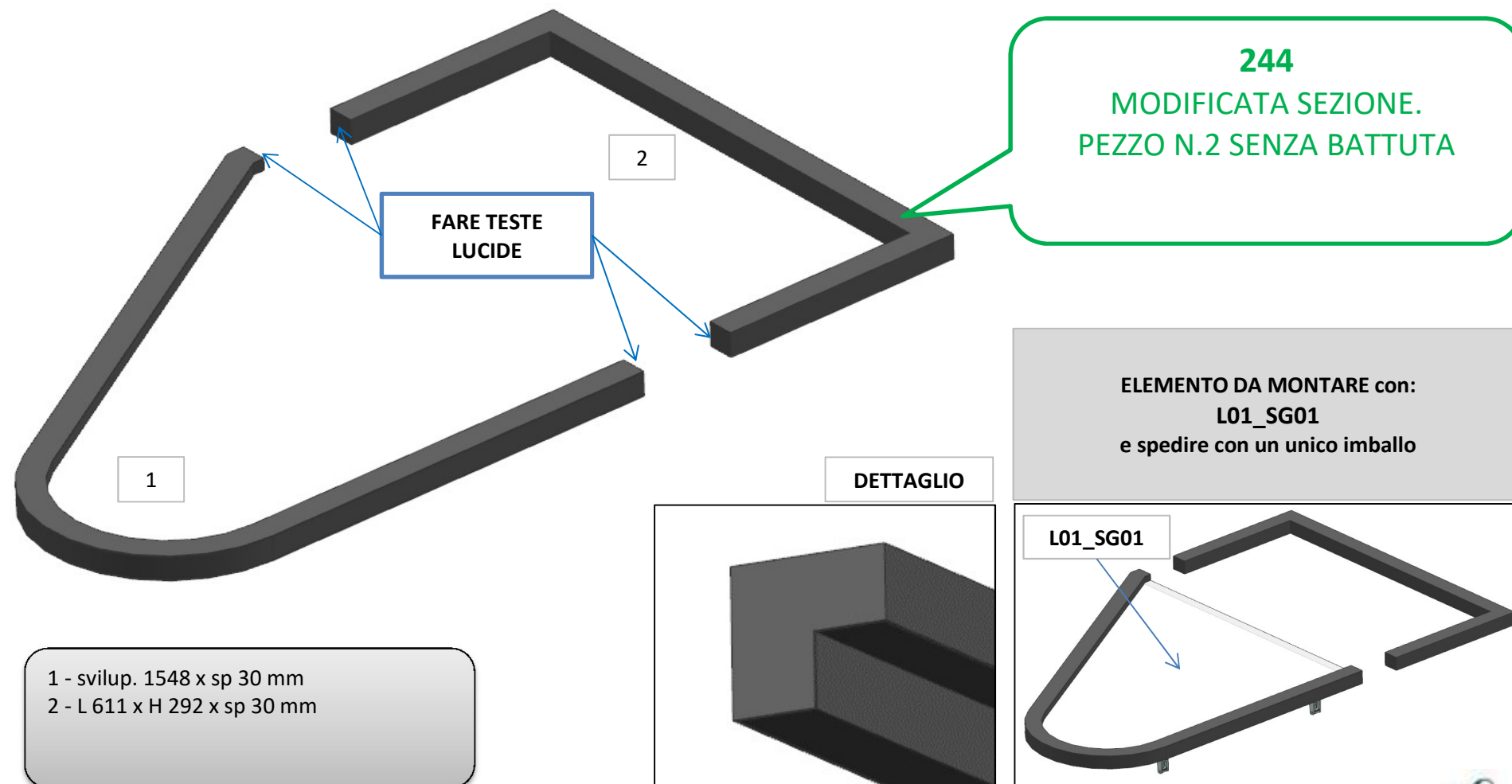

1 - svilup. 1548 x sp 30 mm  
2 - L 611 x H 292 x sp 30 mm