

AZ68F

DA MAT. 265 REV. 29-04-2024

LOCALE	CODICE	DESCRIZIONE COMPONENTE	FINITURA	Q.TA	OPERATORE
CUCINA	AZ68F-MF_KH01	PARETE TV E LATO GUIDA			Damiano

RETRO

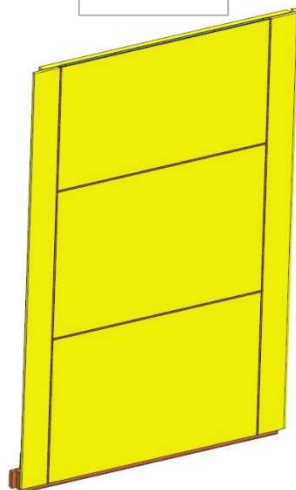

KH01

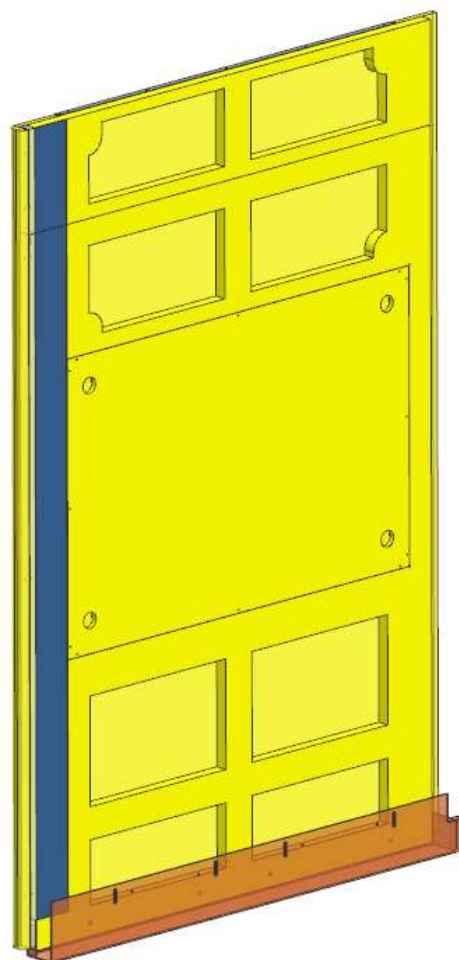

KH02

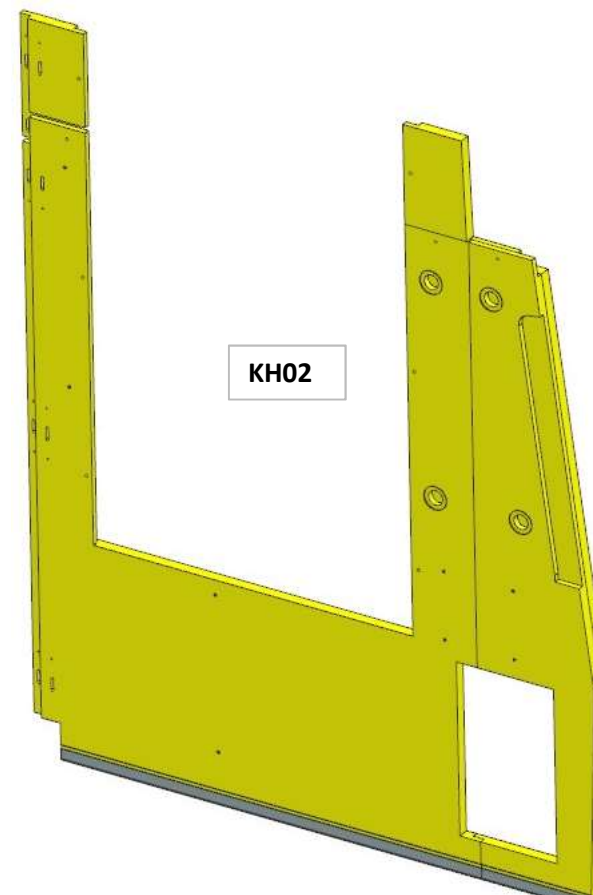

FERRAMENTA:

- N° 28 - FITLOCK MASCHIO
- N° 28 - FITLOCK FEMMINA
- N° 4 - SOUTHCO
- N° 4 - RISCONTRO SOUTHCO
- N°24 - SPINE 8x39 mm misura finita
- N° 31 - VITI 6MA X25 TS
- N° 20 - BUSSOLA ZAMA
- N° 2 - PIEDINO REGOLABILE

AZ68F

DA MAT. 265 REV. 29-04-2022

LOCALE	CODICE	DESCRIZIONE COMPONENTE	FINITURA	Q.TA	OPERATORE
CUCINA	AZ68F-KH01	PARETE TV E LATO GUIDA	OKOUME' GREZZO	4	Damiano

1

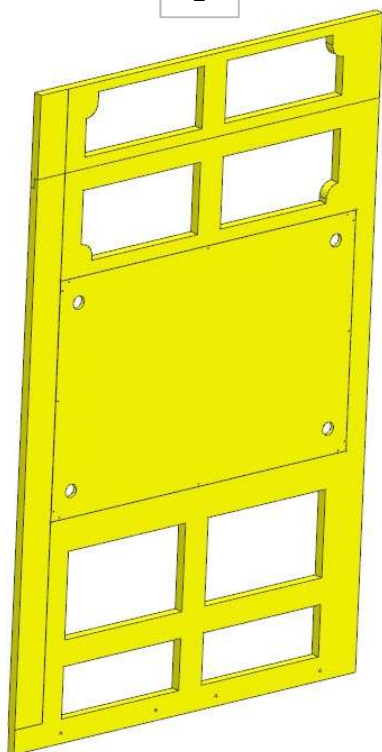

2

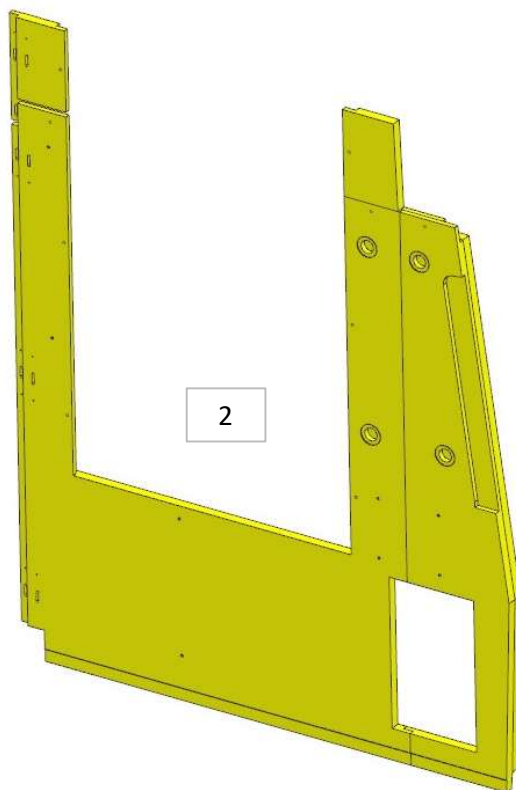

ELEMENTO DA MONTARE con:
MF_KH01
MF_KH02
MF_KH03
MF_KH04
e spedire con un unico imballo

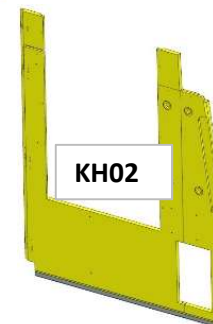

AZ68F

DA MAT. 265 REV. 29-04-2024

LOCALE	CODICE	DESCRIZIONE COMPONENTE	FINITURA	Q.TA	OPERATORE
CUCINA	AZ68F-I01_KH01	PARETE TV E LATO GUIDA	OKOUME' GREZZO	8	Damiano

**248
MODIFICA
DIMENSIONE**

- 1 - L 152.5 x H 1972 x sp 50 mm
- 2 - L 1047 x H 584.5 x sp 15 mm
- 3 - L 1047 x H 692 x sp 30 mm
- 4 - L 388 x H 609 x sp 15 mm
- 5 - L 1047 x H 677.5 x sp 15 mm
- 6 - L 152.5 x H 1972 x sp 50 mm
- 7 - L 190 x H 1973 x sp 15 mm
- 8 - L 190 x H 1973 x sp 15 mm

**ELEMENTI DA MONTARE con:
MF_KH01
e spedire con un unico imballo**

KH01

consonni&c

AZ68F

DA MAT. 265 REV. 29-04-2024

LOCALE	CODICE	DESCRIZIONE COMPONENTE	FINITURA	Q.TA	OPERATORE
CUCINA	AZ68F-A01_KH01	PARETE TV E LATO GUIDA	ACCIAIO	2	Damiano

1 - L 1484 x H 30 x sp 30 mm
2 - L 1047 x H 30 x sp 15 mm

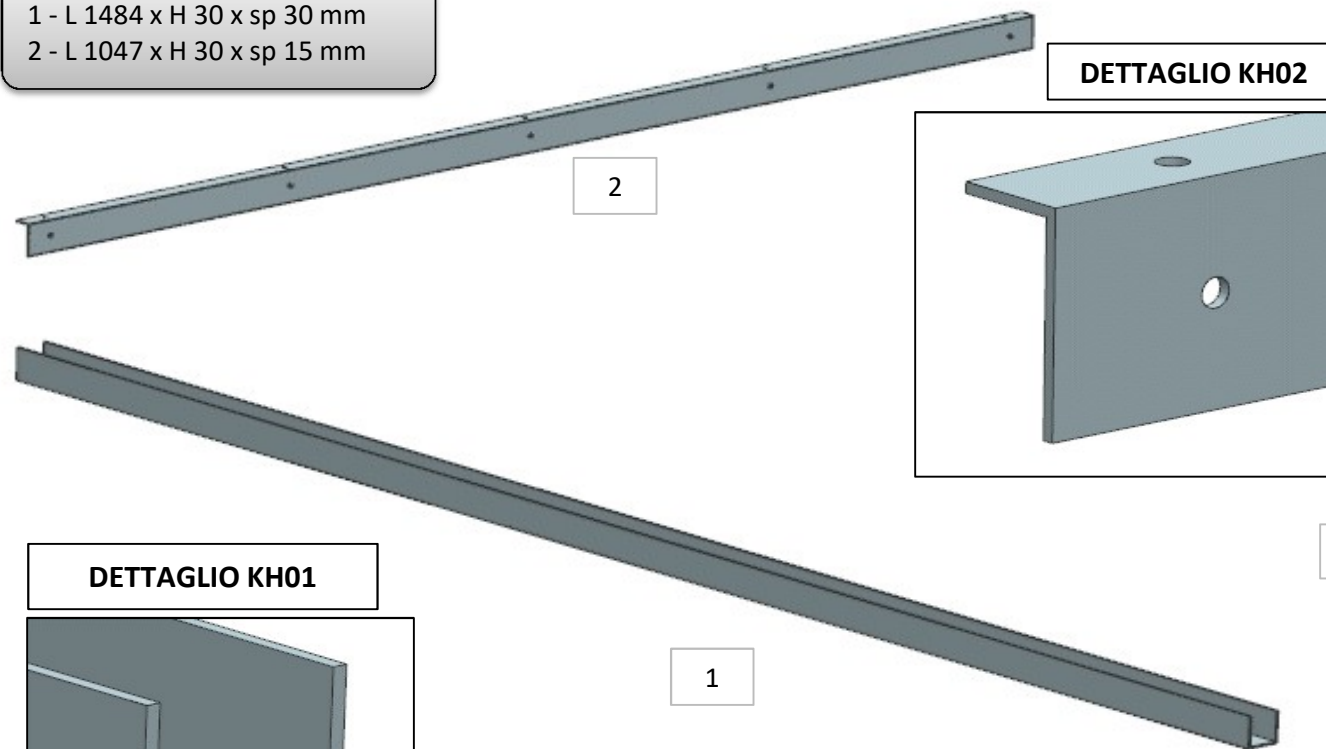

88
AGGIUNTO UN
ACCIAIO

ELEMENTO DA MONTARE con:
MF_KH01
MF_KH02
e spedire con un unico imballo

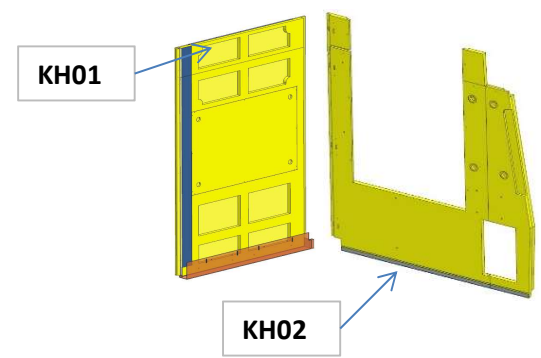
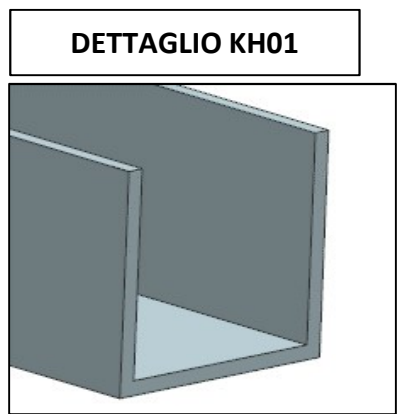

AZ68F

DA MAT.265

REV. 29-04-2024

LOCALE	CODICE	DESCRIZIONE COMPONENTE	FINITURA	Q.TA	OPERATORE
CUCINA	AZ68F-A02_KH01	PARETE TV E LATO GUIDA	ACCIAIO LACCATO BRONZO	7	Damiano

- 1 - L 36 x H 1690 x sp 19 mm
- 2 - L 1050 x H 36 x sp 19 mm
- 3 - L 1050 x H 36 x sp 19 mm
- 4 - L 36 x H 1690 x sp 19 mm
- 5 - L 1303 x H 147 x pr 83 mm
- 6 - L 36 x H 284 x sp 19 mm

209
PEZZI N.1 E N.4
ACCORCIATI E
AGGIUNTI PEZZI N.6
E N.7

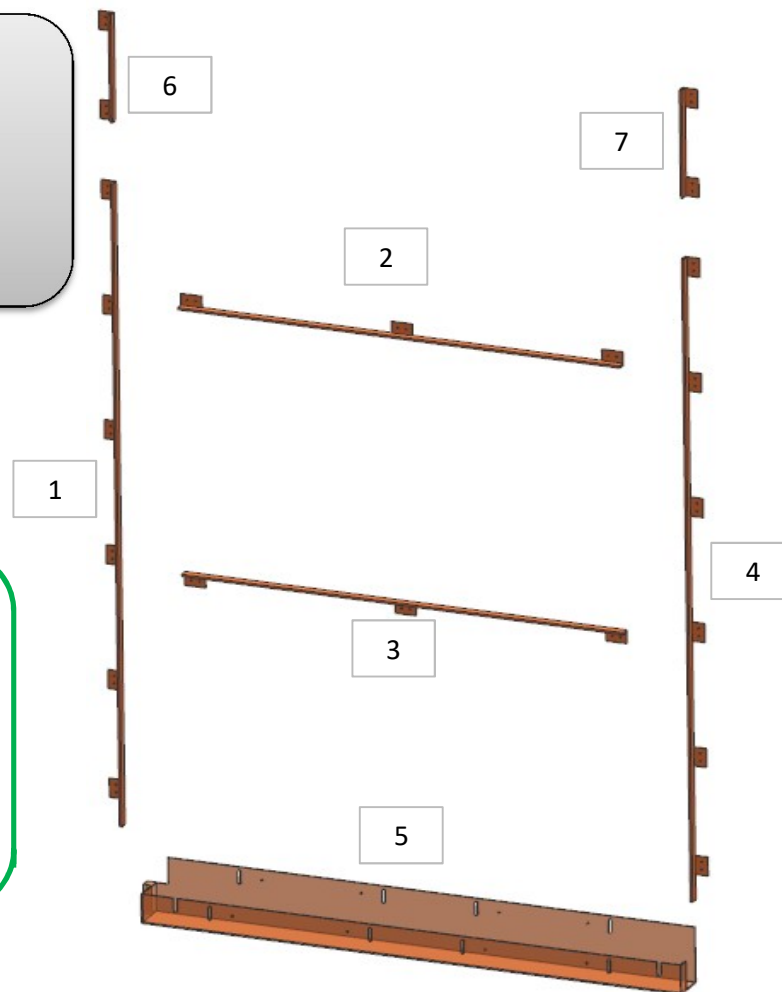

ELEMENTO DA MONTARE con:
MF_KH01
e spedire con un unico imballo

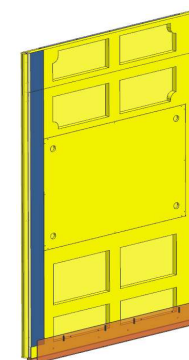

KH01

AZ68F

DA MAT. 265 REV. 29-04-2024

LOCALE	CODICE	DESCRIZIONE COMPONENTE	FINITURA	Q.TA	OPERATORE
CUCINA	AZ68F-L01_KH01	PARETE TV E LATO GUIDA	LACCATO BIANCO ARTICO	7	Damiano

- 1 - L 81.5 x H 815 x sp 15 mm
- 2 - L 895 x H 470 x sp 15 mm
- 3 - L 895 x H 185 x sp 15 mm
- 4 - L 965 x H 1372.5 x sp 15 mm
- 5 - L 450 x H 816 x sp 15 mm

* faccia dove viene applicata la finitura
↓ filo dove viene applicata la finitura

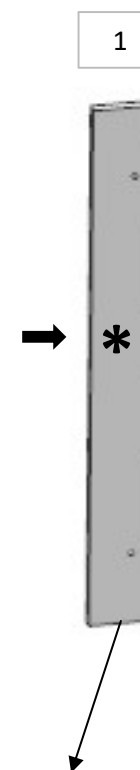
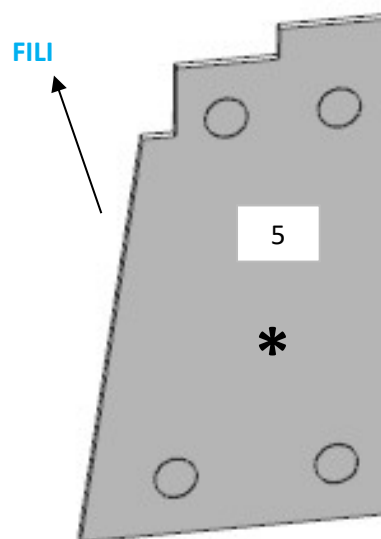

AZ68F

DA MAT. 203 REV. 29-04-2024

LOCALE	CODICE	DESCRIZIONE COMPONENTE	FINITURA	Q.TA	OPERATORE
CUCINA	AZ68F-MF_KI01	PARETE POPPA LANTERNA-OPT			Damiano

FERRAMENTA:

N° 22 - FITLOCK MASCHIO
N° 22- FITLOCK FEMMINA
N° 9 - BUSSOLA ZAMA 6MA

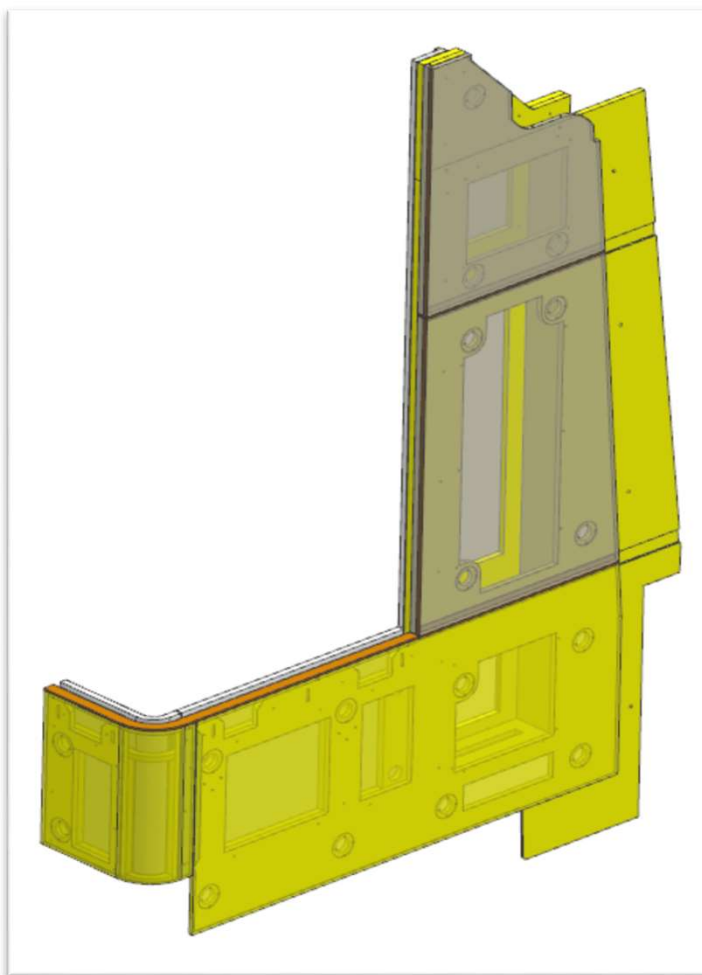

AZ68F

DA MAT. 203 REV. 29-04-2022

LOCALE	CODICE	DESCRIZIONE COMPONENTE	FINITURA	Q.TA	OPERATORE
CUCINA	AZ68F-KI01	PARETE POPPA LANTERNA-OPT	OKOUME' GREZZO	2	Damiano

1 - L 429.5 x H 320 x 100 mm
2 - L 1574 x H 2012 x 326 mm

FERRAMENTA:

N° 22 - FITLOCK MASCHIO
N° 22 - FITLOCK FEMMINA
N° 9 - BUSSOLA ZAMA 6MA

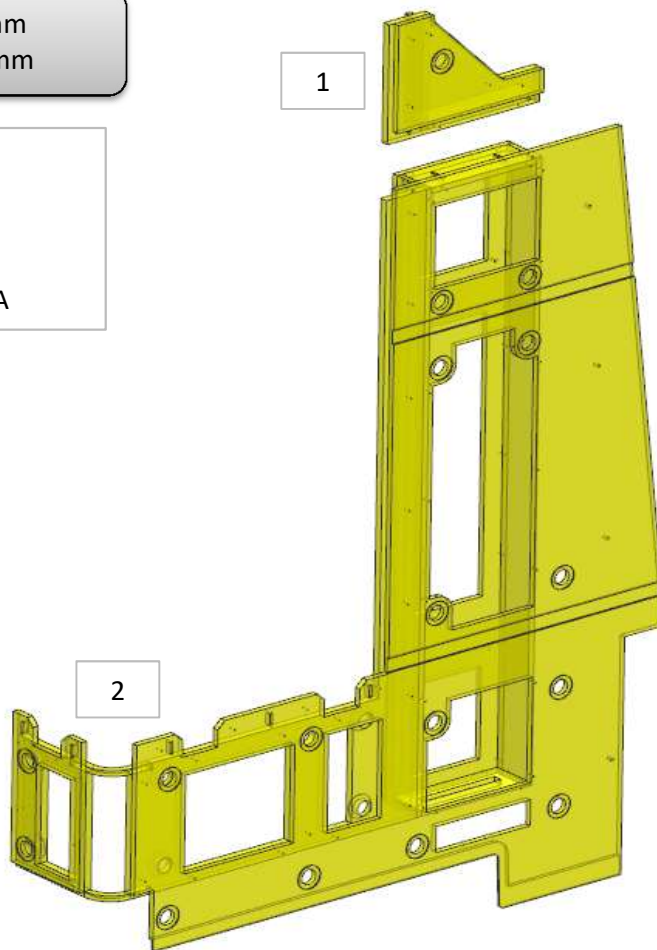

ELEMENTO DA MONTARE con:

R01_KI01
R02_KI01
L01_KI01
X01_KI01

e spedire con un unico imballo

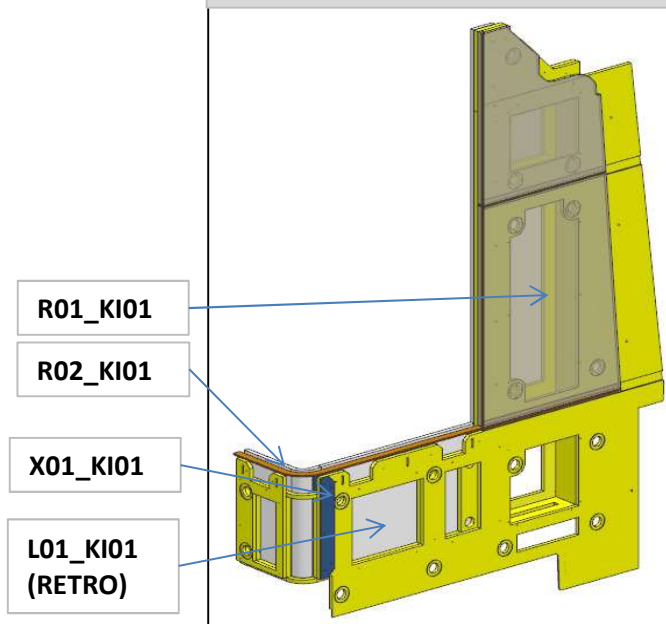

AZ68F

DA MAT. 216 REV. 29-04-2024

LOCALE	CODICE	DESCRIZIONE COMPONENTE	FINITURA	Q.TA	OPERATORE
CUCINA	AZ68F-R01_KI01	PARETE POPPA LANTERNA-OPT	LASTRA CHIARA	2	Damiano

1 - L 530 x H 682.5 x 28.5 mm
 2 - L 595 x H 872 x 29 mm

ID1252-232
 MODIFICA SAGOMA PER
 ACCOPPIAMENTO CON
 VETRORESINA

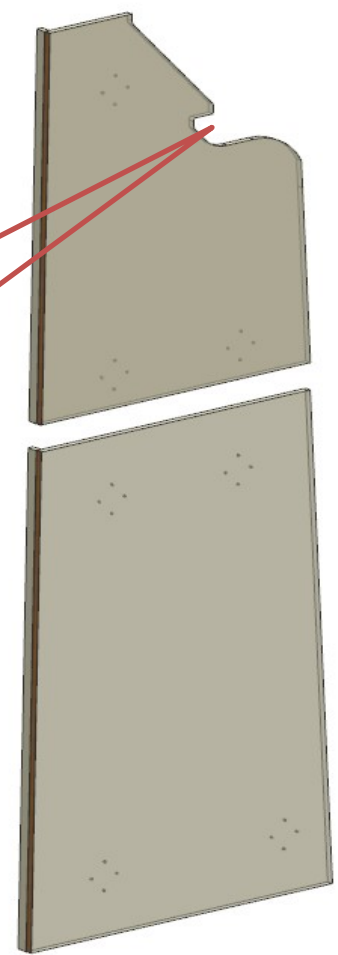

1

2

CUCINA CHIUSA

ELEMENTO DA MONTARE con:
KI01
R02_KI01
L01_KI01
X01_KI01
 e spedire con un unico imballo

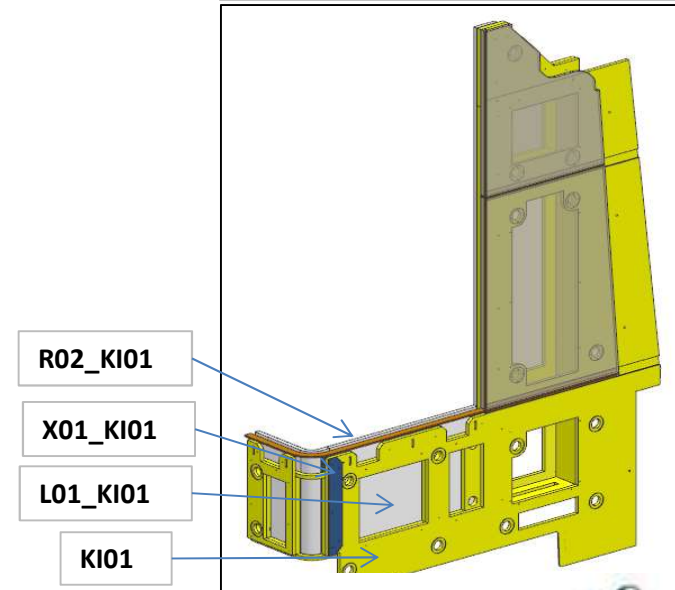

R02_KI01

X01_KI01

L01_KI01

KI01

AZ68F

DA MAT. 207 REV. 29-04-2024

LOCALE	CODICE	DESCRIZIONE COMPONENTE	FINITURA	Q.TA	OPERATORE
CUCINA	AZ68F-R02_KI01	PARETE POPPA LANTERNA-OPT	LASTRA TEAK	3	Damiano

1 - L 797.5 x H 340 x sp 6 mm
2 - L 595 x H 36 x 20 mm
3 - L 530.5 x H 36 x 20 mm

ID-1466
DA 211 VERIFICARE
SENSO VENA E
SPESSORE

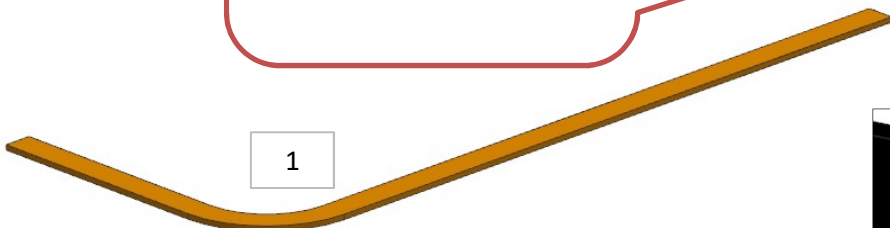

66
VERIFICARE CHE I
TEACK SIANO FATTI IN
UN PEZZO UNICO

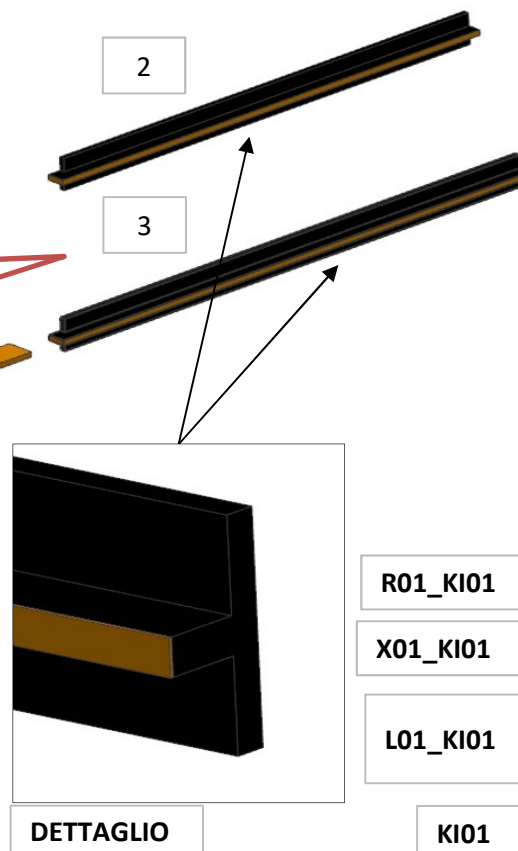

ELEMENTO DA MONTARE con:
KI01
R01_KI01
L01_KI01
X01_KI01
e spedire con un unico imballo

R01_KI01

X01_KI01

L01_KI01

KI01

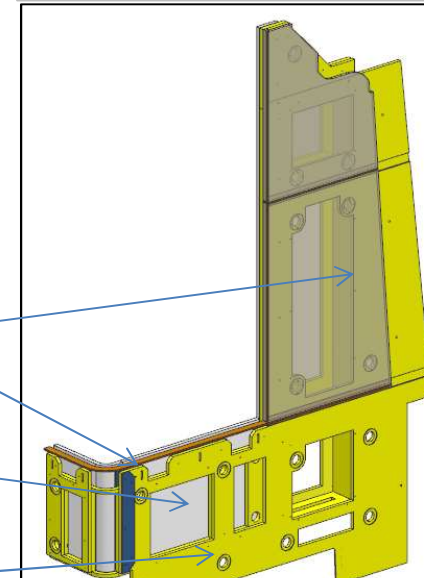

consonni&c

AZ68F

DA MAT. 203 REV. 29-04-2024

LOCALE	CODICE	DESCRIZIONE COMPONENTE	FINITURA	Q.TA	OPERATORE
CUCINA	AZ68F-L01_KI01	PARETE POPPA LANTERNA-OPT	LACCATO BIANCO ARTICO	3	Damiano

- 1 - L 291 x H 426 x sp 17.5 mm
- 2 - L 661 x H 426 x sp 17.5 mm
- 3 - L 92 x H 1987 x sp 15 mm

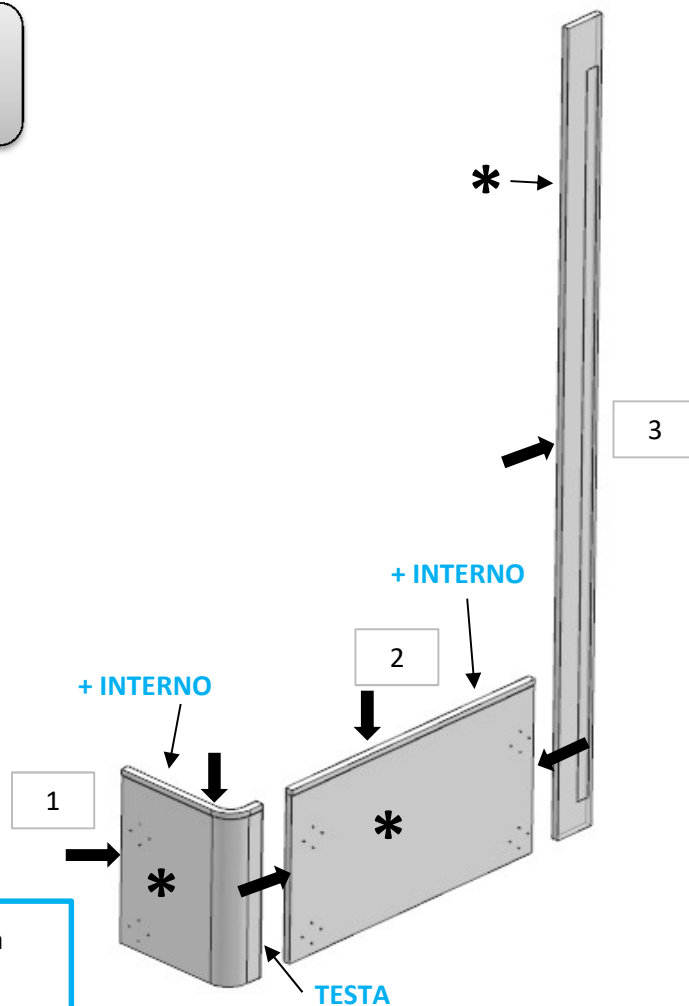

* faccia dove viene applicata la finitura
 ↓ filo dove viene applicata la finitura

ELEMENTO DA MONTARE con:
KI01
R01_KI01
R02_KI01
X01_KI01
 e spedire con un unico imballo

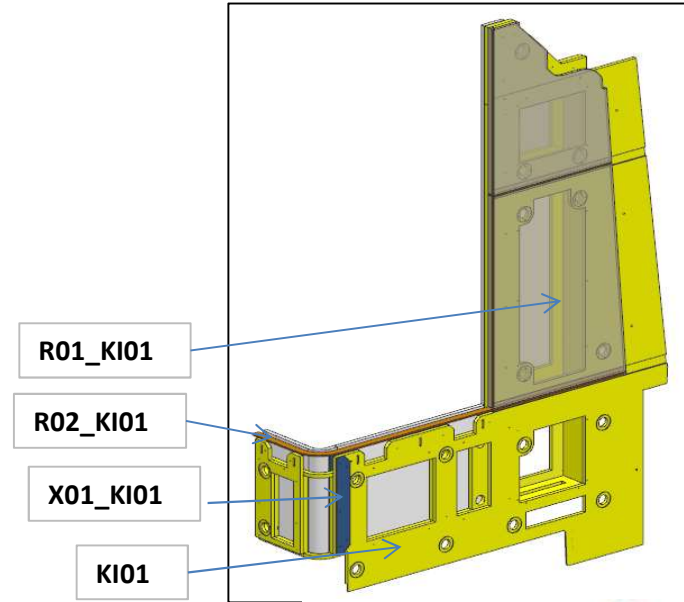

AZ68F

DA MAT. 203 REV. 29-04-2024

LOCALE	CODICE	DESCRIZIONE COMPONENTE	FINITURA	Q.TA	OPERATORE
CUCINA	AZ68F-I01_KI01	PARETE POPPA LANTERNA-OPT	OKOUME' GREZZO	2	Damiano

1 - L 1267 x H 584 x sp 28mm
2 - L 338 x H 419 x sp 28mm

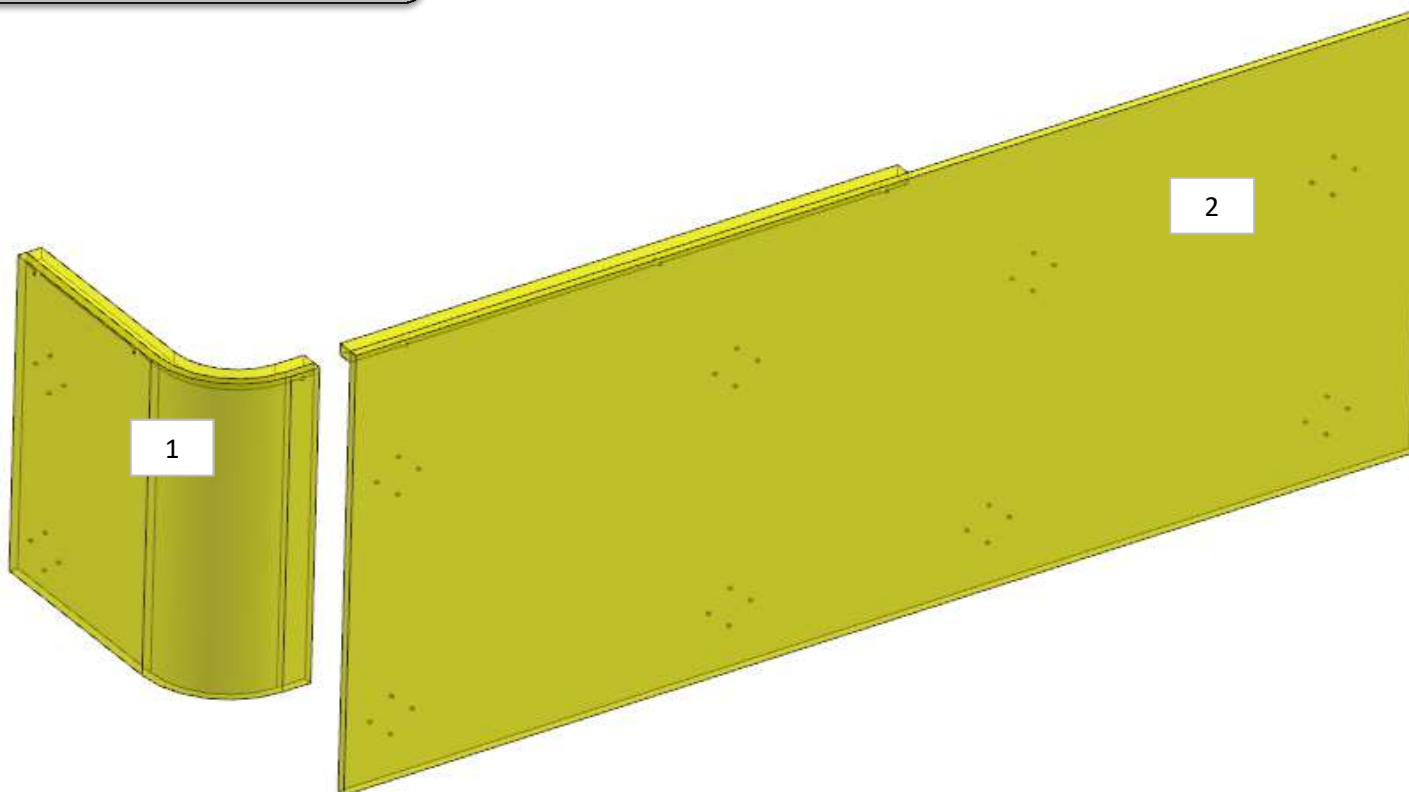

ELEMENTO DA MONTARE con:
MF_KI01
e spedire con un unico imballo

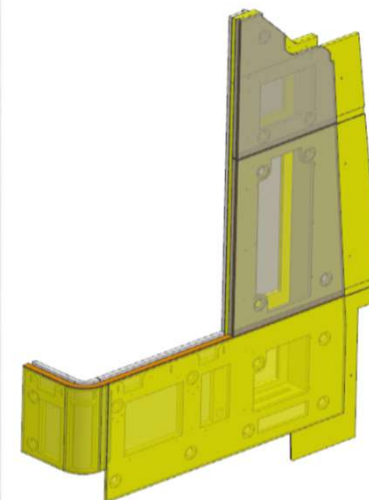

consonni&c

AZ68F

DA MAT. 203 REV. 20-04-2021

LOCALE	CODICE	DESCRIZIONE COMPONENTE	FINITURA	Q.TA	OPERATORE
CUCINA	AZ68F-X01_KI01	PARETE POPPA LANTERNA-OPT	LAMINATO NERO	2	Damiano

1 - L 60 x H 402 x sp 2 mm
2 - L 60 x H 402 x sp 2 mm

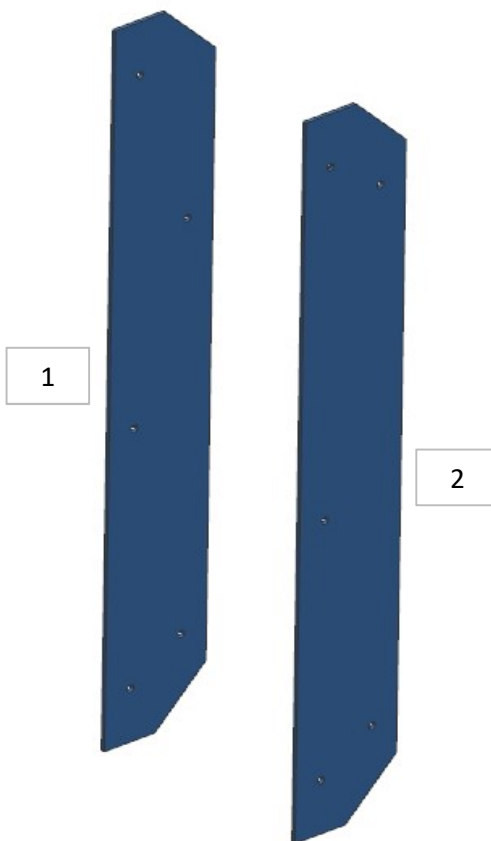

ELEMENTO DA MONTARE con:
KI01
R01_KI01
R02_KI01
L01_KI01
e spedire con un unico imballo

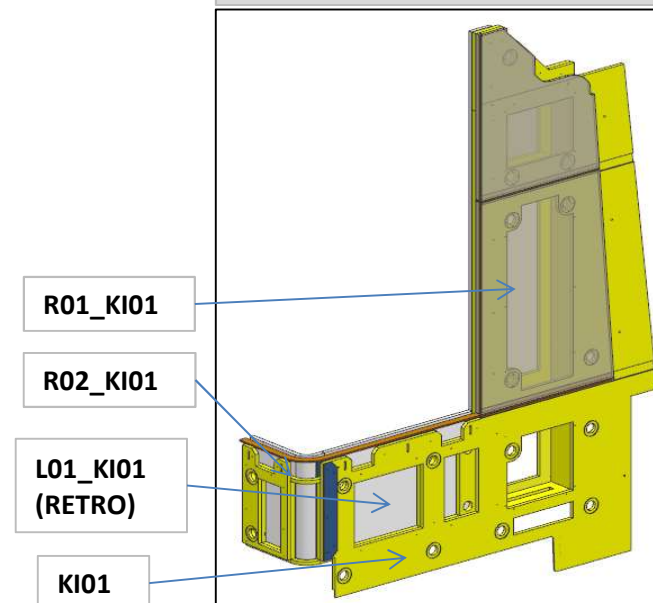

consonni&c

AZ68F

REV. 29-04-2024

LOCALE	CODICE	DESCRIZIONE COMPONENTE	FINITURA	Q.TA	OPERATORE
CUCINA	AZ68F-MF_KQ01	PARETE POPPA-STD			Damiano

FERRAMENTA:

N° 16 - FITLOCK MASCHIO
N° 14 - FITLOCK FEMMINA
N° 12 - BUSSOLA ZAMA 6MA
N° 2 - VITI 6MA X 25 TB

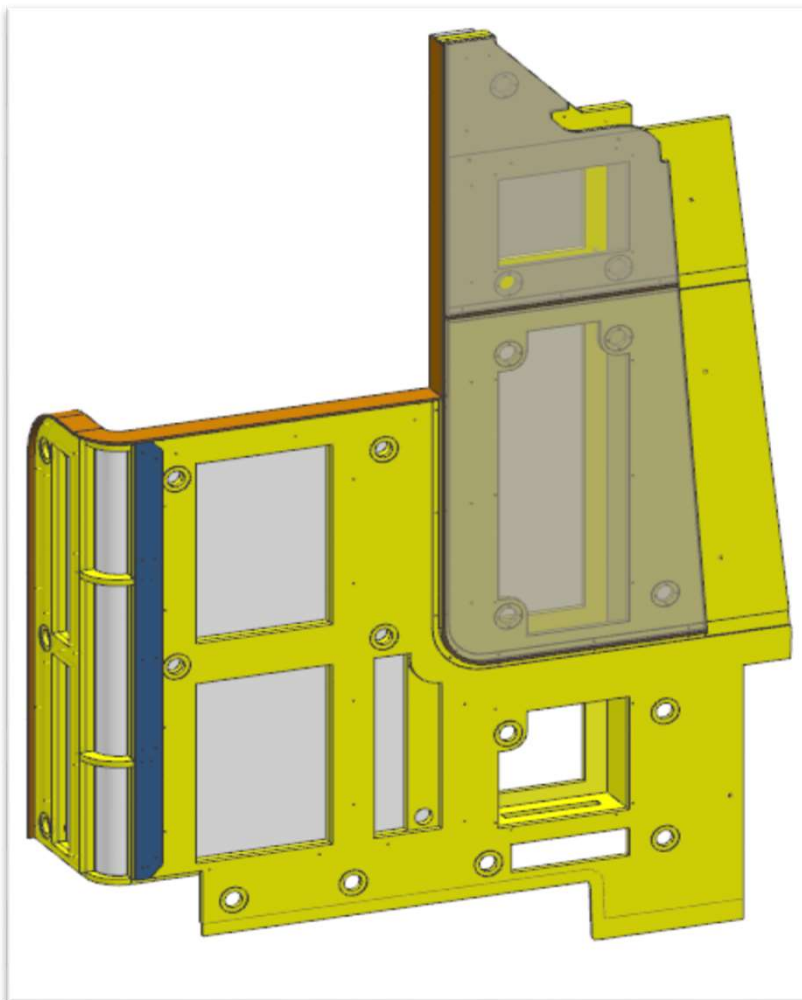

consonni&c

AZ68F

DA MAT. 203 REV. 29-04-2022

LOCALE	CODICE	DESCRIZIONE COMPONENTE	FINITURA	Q.TA	OPERATORE
CUCINA	AZ68F-KQ01	PARETE POPPA-STD	OKOUME' GREZZO	2	Damiano

1 - L 439 x H 320 x 100 mm
2 - L 1574 x H 2012 x 326 mm

57
SPOSTATO
FITLOCK PER
IMBOTTITI

FERRAMENTA:

N° 16 - FITLOCK MASCHIO
N° 14 - FITLOCK FEMMINA
N° 12 - BUSSOLA ZAMA 6MA
N° 2 - VITI 6MA X 25 TB

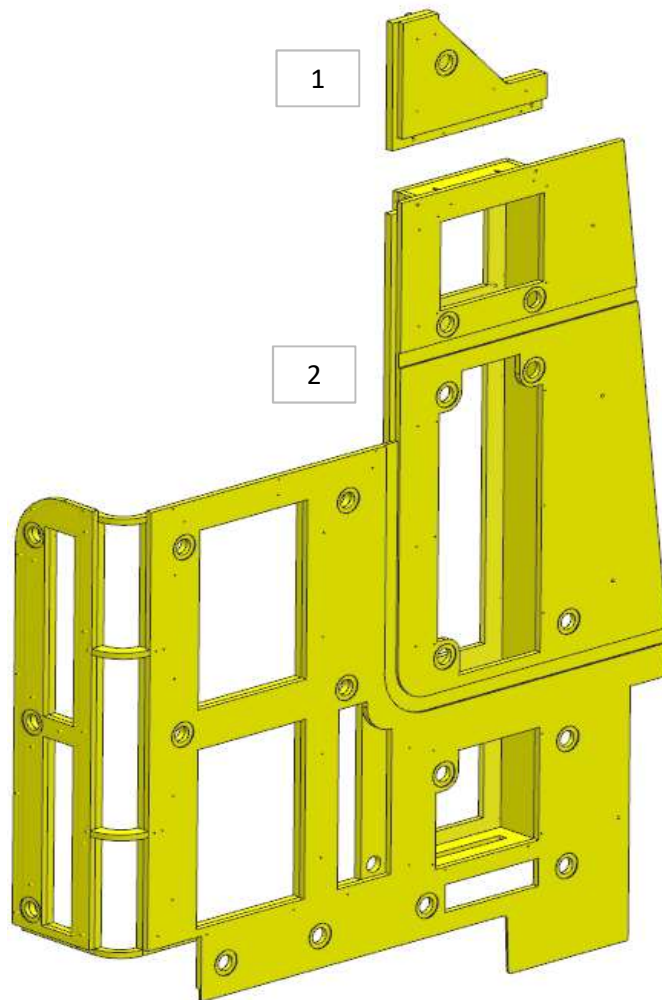

ELEMENTO DA MONTARE con:

R01_KQ01

R02_KQ01

L01_KQ01

X01_KQ01

e spedire con un unico imballo

R02_KQ01

L01_KQ01

X01_KQ01

R01_KQ01

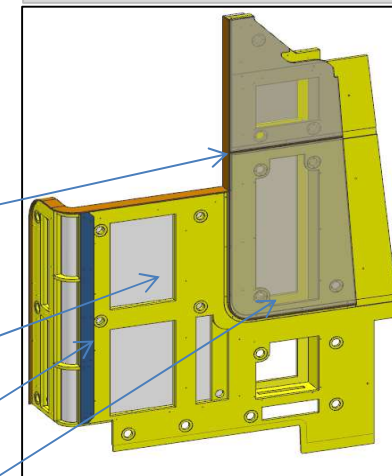

AZ68F

DA MAT. 216 REV. 29-04-2024

LOCALE	CODICE	DESCRIZIONE COMPONENTE	FINITURA	Q.TA	OPERATORE
CUCINA	AZ68F-R01_KQ01	PARETE POPPA-STD	LASTRA CHIARA	2	Damiano

1 - L 530.5 x H 682.5 x sp 11 mm
 2 - L 595 x H 872 x sp 11 mm

ID1252-232
 MODIFICA SAGOMA PER
 ACCOPPIAMENTO CON
 VETRORESINA

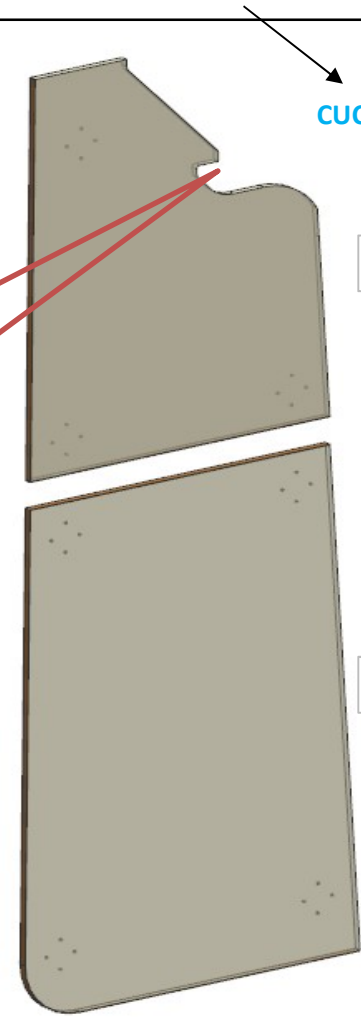

CUCINA APERTA

1

2

ELEMENTO DA MONTARE con:
KQ01
R02_KQ01
L01_KQ01
X01_KQ01
 e spedire con un unico imballo

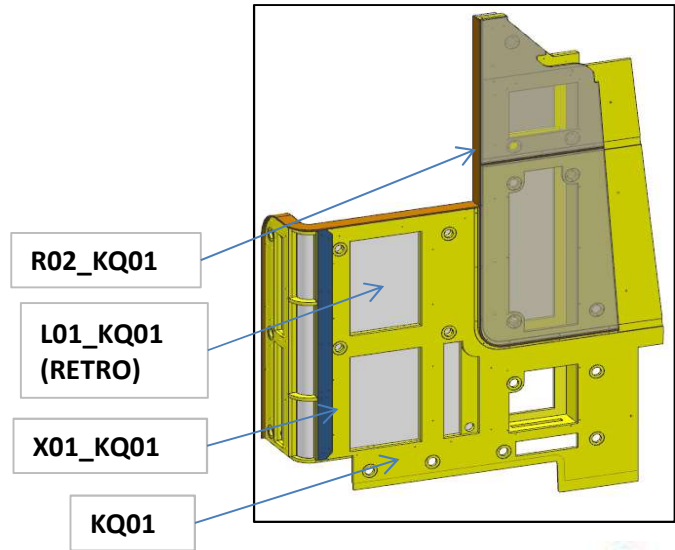

AZ68F

DA MAT. 207 REV. 29-04-2024

LOCALE	CODICE	DESCRIZIONE COMPONENTE	FINITURA	Q.TA	OPERATORE
CUCINA	AZ68F-R02_KQ01	PARETE POPPA-STD	LASTRA TEAK	5	Damiano

- 1 - SVILUPPO 1285 x L 68 x sp 20 mm
- 2 - L 792 x H 68 x 20 mm
- 3 - L 68 x H 688 x 22 mm
- 4 - L 36 x H 530.5 x 20 mm
- 5 - SVILUPPO 1434 x L 68 x sp 20 mm

da mat.207
PEZZI N.2/4/5 IN
MDF LASTRA TEAK

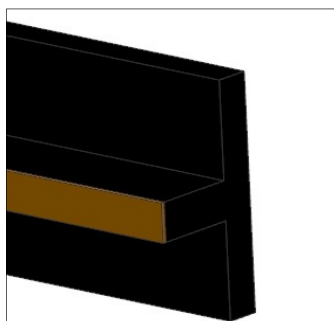

DETTAGLIO

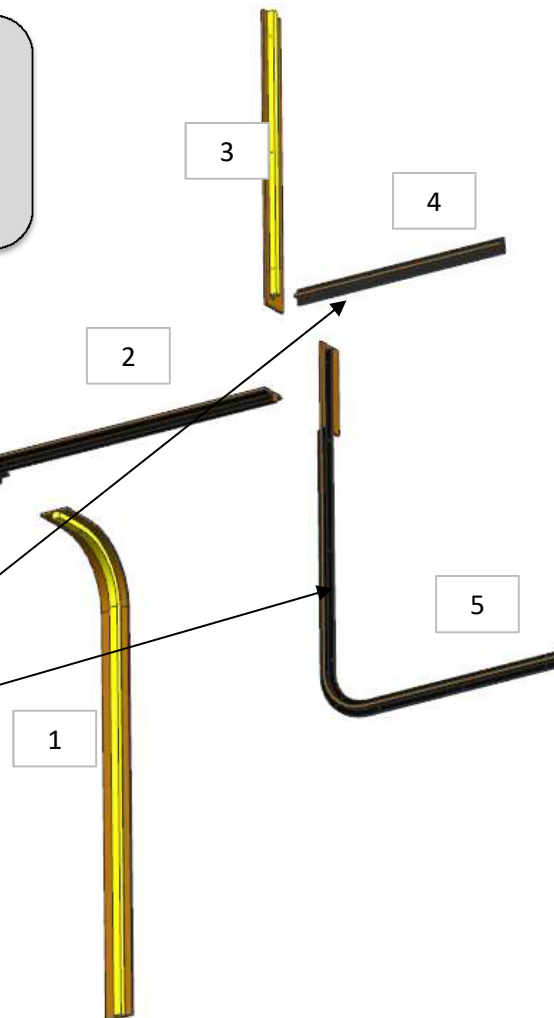

ELEMENTO DA MONTARE con:
KQ01
R01_KQ01
L01_KQ01
X01_KQ01
e spedire con un unico imballo

R01_KQ01

L01_KQ01
(RETRO)

X01_KQ01

KQ01

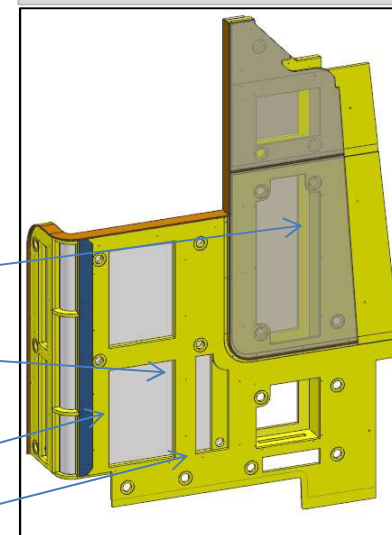

consonni&c

AZ68F

DA MAT. 203 REV. 29-04-2024

LOCALE	CODICE	DESCRIZIONE COMPONENTE	FINITURA	Q.TA	OPERATORE
CUCINA	AZ68F-L01_KQ01	PARETE POPPA-STD	LACCATO BIANCO ARTICO	3	Damiano

- 1 - L 92 x H 1987 x sp 16 mm
- 2 - L 661 x H 1099 x sp 15.5 mm
- 3 - L 289 x H 1099 x 85 mm

**FARE MOLTA ATTENZIONE
ALLA VERNICIATURA DEL
BORDINO DEI PEZZI 2 e 3 IN
QUANTO È A VISTA**

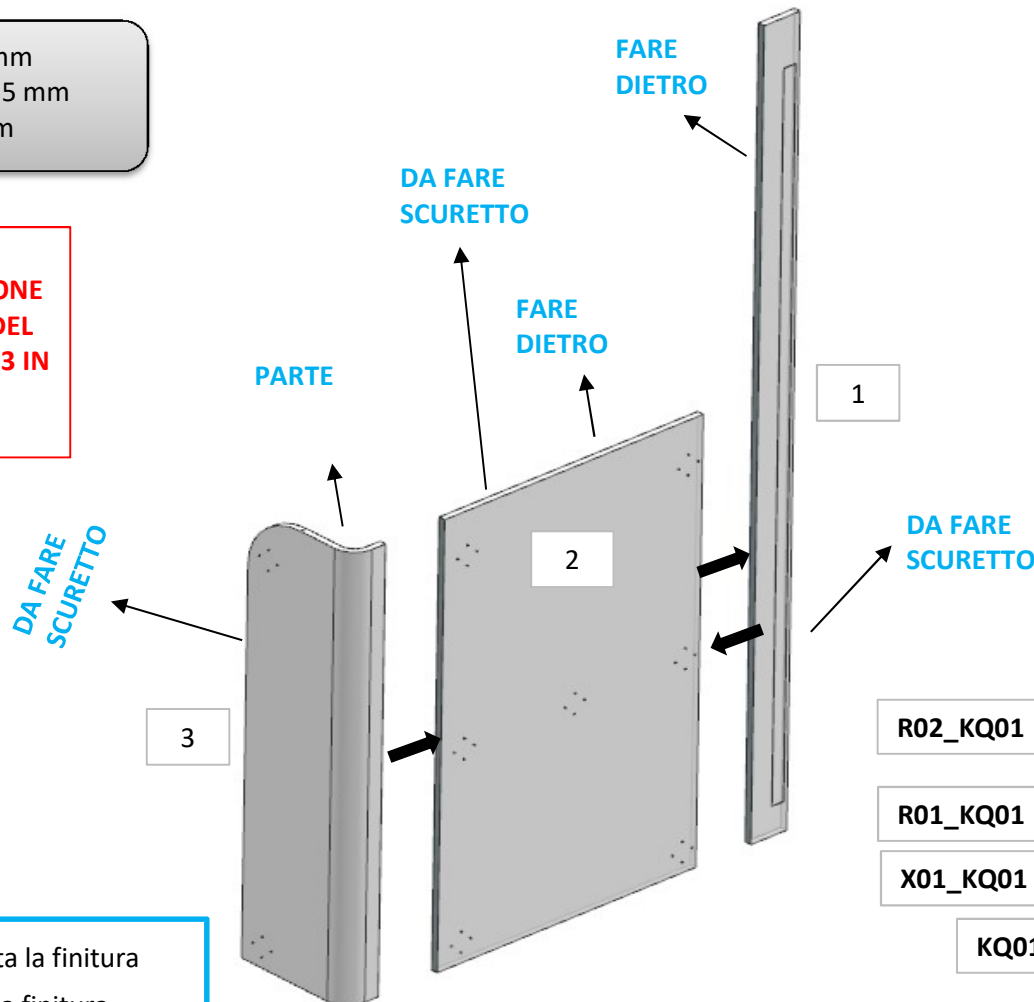

ELEMENTO DA MONTARE con:
KQ01
R01_KQ01
R02_KQ01
X01_KQ01
 e spedire con un unico imballo

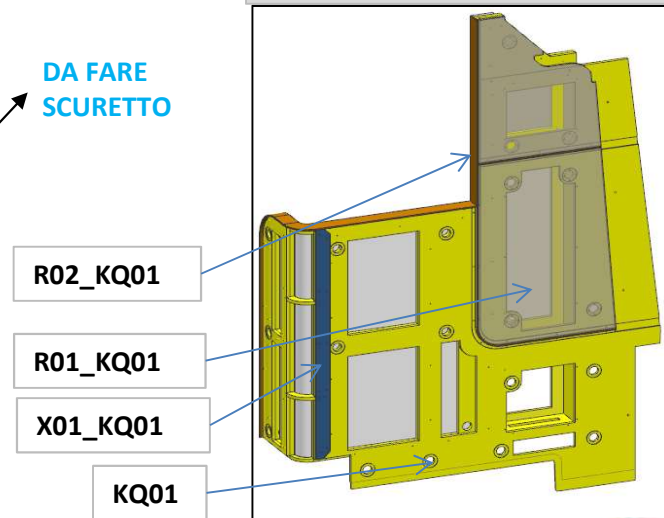

* faccia dove viene applicata la finitura
 ↓ filo dove viene applicata la finitura

AZ68F

DA MAT. 203 REV. 29-04-2024

LOCALE	CODICE	DESCRIZIONE COMPONENTE	FINITURA	Q.TA	OPERATORE
CUCINA	AZ68F-I01_KQ01	PARETE POPPA-STD	OKOUME' GREZZO	2	Dante

1 - L 1267 x H 1263 x sp 10 mm
2 - L 338 x H 1098 x 133.5 mm

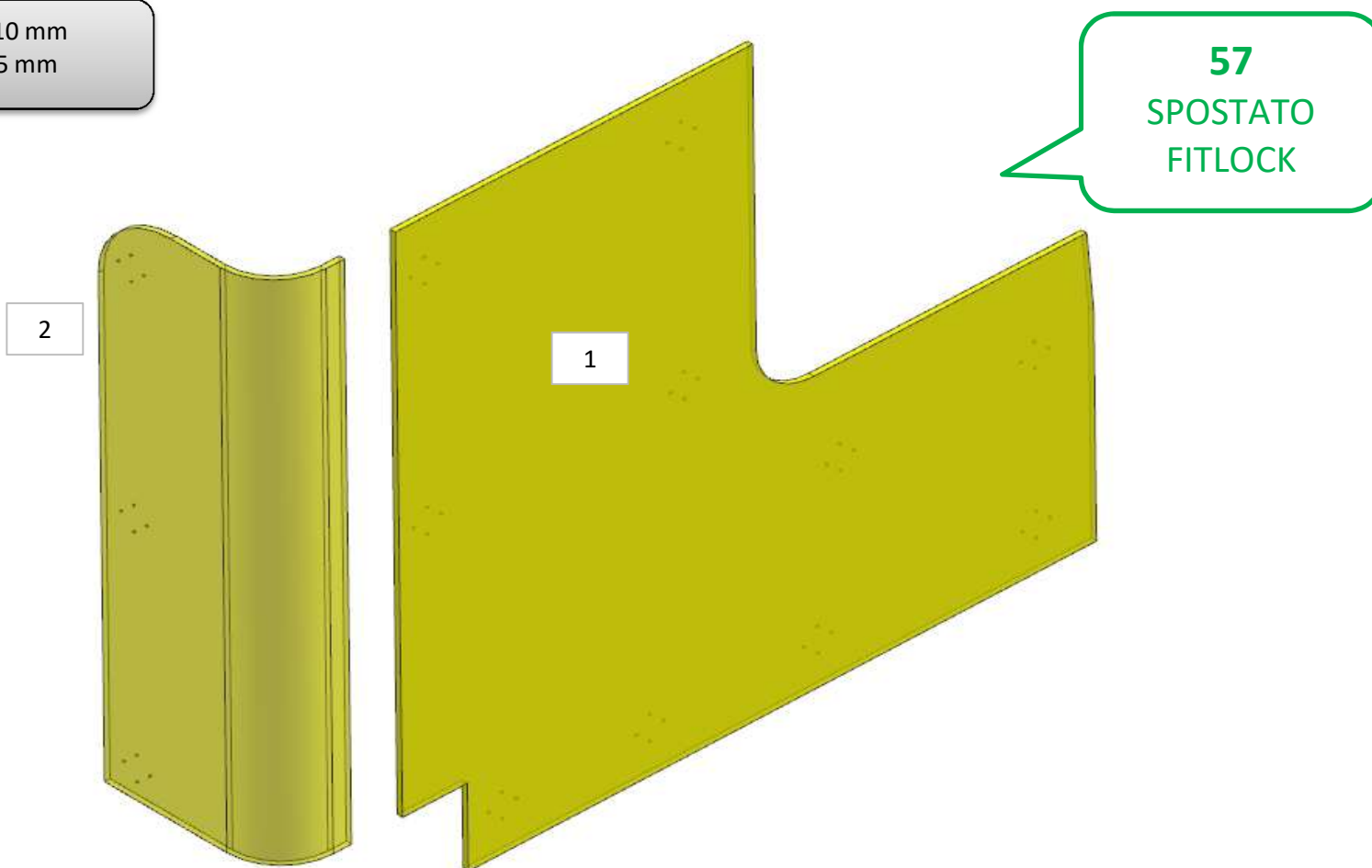

AZ68F

DA MAT. 203 REV. 20-04-2021

LOCALE	CODICE	DESCRIZIONE COMPONENTE	FINITURA	Q.TA	OPERATORE
CUCINA	AZ68F-X01_KQ01	PARETE POPPA-STD	LAMINATO NERO	2	Damiano

1 - L 60 x H 1098 x sp 2 mm
2 - L 60 x H 1098 x sp 2 mm

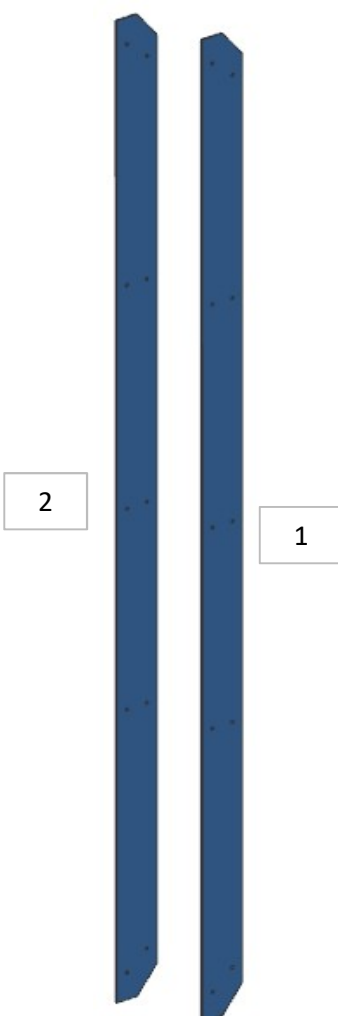

ELEMENTO DA MONTARE con:
KQ01
R01_KQ01
R02_KQ01
L01_KQ01
e spedire con un unico imballo

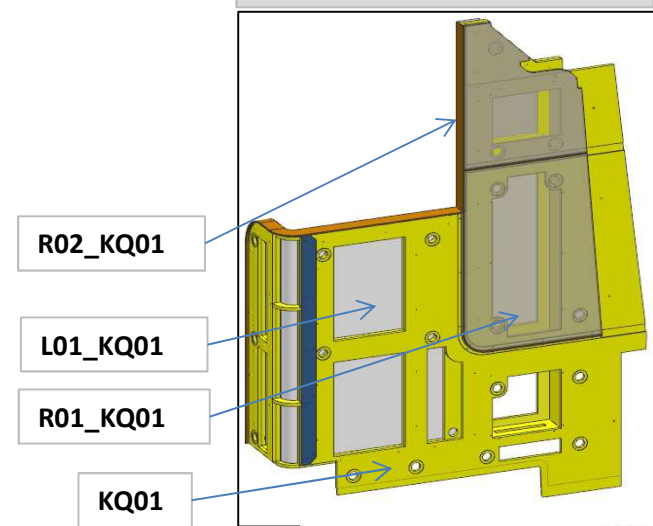

AZ68F

DA MAT. 201 REV. 20-04-2021

LOCALE	CODICE	DESCRIZIONE COMPONENTE	FINITURA	Q.TA	OPERATORE
CUCINA	AZ68F-X01_KS01	PAVIMENTO	LAMINATO OLIMPUS OL04	2	Damiano

1 - L 2160 x H 848 - 879 x sp 12
2 - L 305 x H 48 x sp 12

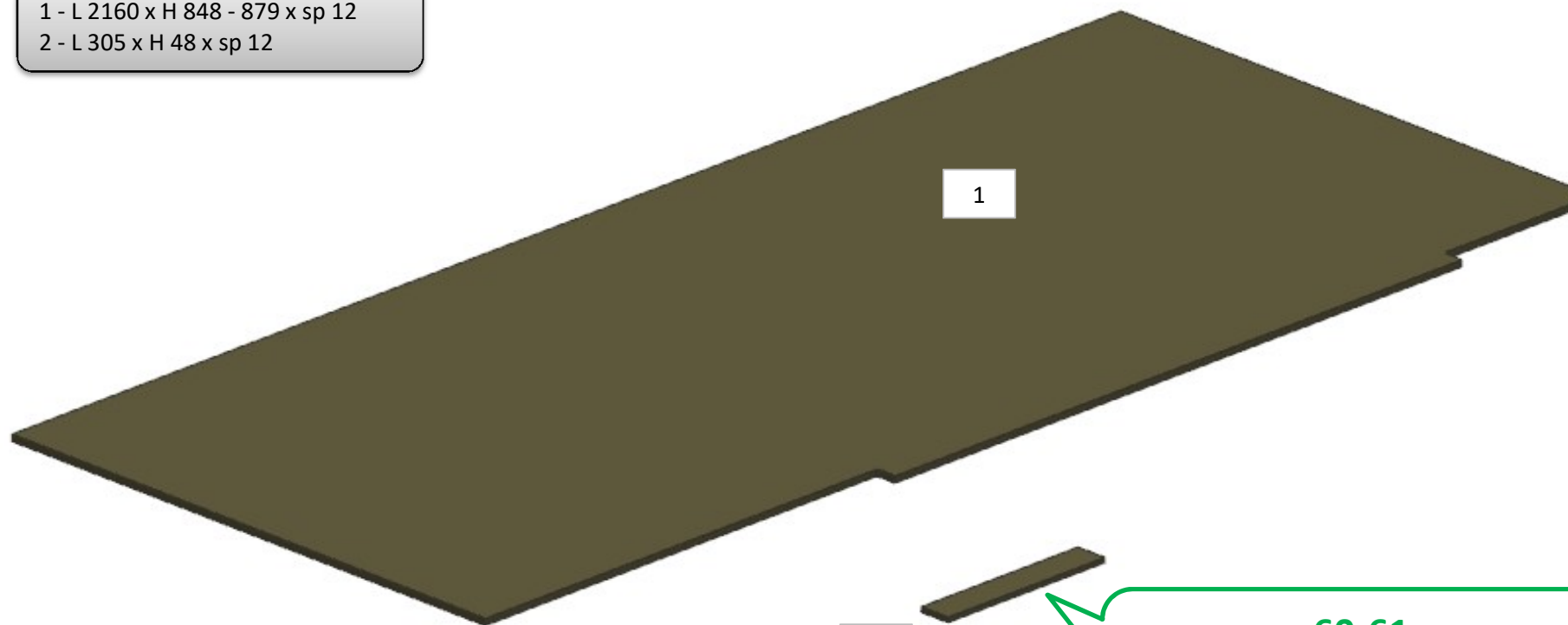

60-61
MODIFICATA SAGOMA E
AGGIUNTO PZ. n° 2